I. INTRODUCTION



I. INTRODUCTION

Developing Advanced Combustion Engine Technologies

On behalf of the Department of Energy's Office of FreedomCAR and Vehicle Technologies, we are pleased to introduce the Fiscal Year (FY) 2006 Annual Progress Report for the Advanced Combustion Engine R&D Sub-Program. The mission of the FreedomCAR and Vehicle Technologies (FCVT) Program is to develop more energy-efficient and environmentally friendly highway transportation technologies that enable America to use less petroleum. The Advanced Combustion Engine R&D Sub-Program supports this mission and the President's initiatives by removing the critical technical barriers to commercialization of advanced internal combustion engines for light-, medium-, and heavy-duty highway vehicles that meet future Federal and state emissions regulations. The primary goal of the Advanced Combustion Engine R&D Sub-Program is to improve the brake thermal efficiency of internal combustion engines:

- for passenger vehicles, from 30% (2002 baseline) to 45% by 2010, and
- for commercial vehicle applications, 40% (2002 baseline) to 55% by 2013,

while meeting cost, durability, and emissions constraints. R&D activities include work on combustion technologies that increase efficiency and minimize in-cylinder formation of emissions, as well as aftertreatment technologies that further reduce exhaust emissions. Research is also being conducted on approaches to produce useful work from waste engine heat through the development and application of thermoelectrics, electricity generation from exhaust-driven turbines, and incorporation of energy-extracting bottoming cycles.

Advanced internal combustion engines are a key element in the pathway to achieving the goals of the President's FreedomCAR and Fuel Partnership for transportation. Advanced engine technologies being researched will allow use of hydrogen as a fuel in highly efficient and low-emission internal combustion engines, providing an energy-efficient interim hydrogen-based powertrain technology during the transition to hydrogen/fuel-cell-powered transportation vehicles. Hydrogen engine technologies being developed have the potential to provide diesel-like engine efficiencies with near-zero air pollution and greenhouse gas emissions.

This introduction serves to outline the nature, recent progress, and future directions of the Advanced Combustion Engine R&D Sub-Program. The research activities of this Sub-Program are planned in conjunction with the FreedomCAR and Fuel Partnership and the 21st Century Truck Partnership and are carried out in collaboration with industry, national laboratories, and universities. Because of the importance of clean fuels in achieving low emissions, R&D activities are closely coordinated with the relevant activities of the Fuel Technologies Sub-Program, also within the Office of FreedomCAR and Vehicle Technologies.

Background

The compression ignition direct injection (CIDI) engine, an advanced version of the commonly known diesel engine, is a promising advanced combustion engine technology for achieving dramatic energy efficiency improvements in light-duty vehicle applications, where it is suited to both conventional and hybrid-electric powertrain configurations. Light-duty vehicles with CIDI engines can compete directly with gasoline engine hybrid vehicles in terms of fuel economy and consumer-friendly driving characteristics; also, they are projected to have energy efficiencies that are competitive with hydrogen fuel cell vehicles. The primary hurdles that must be overcome to realize increased use of CIDI engines in light-duty vehicles are the higher cost of these engines compared to conventional engines and compliance with the U.S. Environmental Protection Agency's (EPA's) Tier 2 regulations which are phasing in from 2004–2009. The Tier 2 regulations require all light-duty vehicles to meet the same emissions standards, regardless of the powertrain. Compliance can be achieved with CIDI engines through the addition of catalytic emission control technologies, though these technologies

are much less mature than gasoline engine catalysts and are severely affected by fuel sulfur. Even the recent reduction of diesel fuel sulfur content to below 15 ppm does not assure that CIDI engine catalytic emission control devices will be durable and cost-effective. The CIDI engine offers a propulsion platform with the potential for further significant efficiency improvements beyond its current capabilities. Although the Advanced Combustion Engine R&D Sub-Program initially sought a wide range of combustion technologies applicable to the CIDI engine, work has since transitioned to focus on advanced low-temperature combustion (LTC) regimes that offer substantial improvements in efficiency and near-zero emissions.

The heavy-duty diesel engine is already the primary engine for commercial vehicles because of its high efficiency and outstanding durability. However, the implementation of more stringent heavy-duty engine emission standards, which are to be phased in starting in 2007 (100% implementation in 2010), is anticipated to cause a reduction in fuel efficiency due to the exhaust emission control devices needed to meet emissions regulations for both oxides of nitrogen (NO_x) and particulate matter (PM).

Given these challenges, the Advanced Combustion Engine Technologies Sub-Program is working toward achieving the following objectives:

- Advance fundamental combustion understanding to enable design of CIDI engines with inherently lower emissions, and eventually advanced engines operating in low-temperature combustion regimes. The resulting technological advances will reduce the size and complexity of emission control devices and minimize any impact these devices have on vehicle fuel efficiency.
- Increase overall engine efficiency through fundamental improvements such as advanced combustion processes, reduction of parasitic losses, and recovery of waste heat.
- Improve the effectiveness, efficiency, and durability of CIDI engine emission control devices to enable these engines to achieve significant penetration in the light-duty market and maintain their application in heavy-duty vehicles.
- Develop highly efficient hydrogen engine technologies with near-zero air pollution and greenhouse gas emissions.

Technology Status

Recent advances in fuel injection systems have made the CIDI engine very attractive for light-duty vehicle use by reducing the combustion noise associated with diesel engines, and consumers are discovering that diesel engines offer outstanding driveability and fuel economy. The change-over to ultra-low-sulfur diesel fuel will enable catalytic exhaust treatment devices that virtually eliminate the offensive odors associated with diesel engines and further improve their prospects for wider use in light-duty vehicles. Mercedes-Benz has started selling a CIDI passenger car that is certified to Tier 2 Bin 8 in the U.S. using a NO_x adsorber and diesel particulate filter (DPF) and has added diesel engine options for its SUVs. Mercedes-Benz has announced that it plans to offer CIDI vehicles in 2008 that meet the Tier 2 Bin 5 standard through the use of selective catalytic reduction (SCR) employing urea for regeneration (urea-SCR). Volkswagen, Audi, and BMW also plan to incorporate urea-SCR technology into their CIDI vehicles in 2008. In 2009, Honda plans to introduce a CIDI passenger car to the U.S. that meets the Tier 2, Bin 5 standard using NO_x adsorber technology and a particulate filter. These products are the direct result of regulation to reduce fuel sulfur content and R&D to develop advanced emission control technologies.

Current heavy-duty diesel engines have efficiencies in the range of 43–45%. These engines have significantly improved efficiency over engines produced just a few years ago. Improvements are being made in a wide variety of engine components such that engines a few years from now may have efficiencies between 47 and 48% without employing waste heat recovery.

Starting in 2007, heavy-duty diesel engines for on-highway commercial trucks will be equipped with DPFs to meet particulate emissions standards. This will be the first very broad application of aftertreatment devices in the trucking industry. In some cases, DPFs are paired with oxidation catalysts to facilitate passive or active regeneration. DPFs are typically capable of reducing PM emissions by

90% or more. For NO_x control, aftertreatment devices are not likely to be needed in the heavy-duty sector until 2010 emissions regulations take effect.

Among the options for NO_x aftertreatment for diesel engines, urea-SCR is the clear leader because of its performance and superior fuel sulfur tolerance. The U.S. EPA is in the process of establishing vehicle design guidelines to assure that urea is widely available and that the proper inducements are in place to assure that users of urea-SCR vehicles don't operate them without replenishing the urea. Using urea-SCR, light-duty manufacturers will be able to meet Tier 2, Bin 5 which is the "gold standard" at which diesel vehicle sales do not have to be offset by sales of lower emission vehicles. Heavy-duty diesel vehicle manufacturers will be attracted to urea-SCR since it has a broader temperature range of effectiveness than competing means of NO_x reduction and allows the engine/emission control system to achieve higher fuel efficiency.

The other technology being considered for NO_x control from CIDI engines is lean-NO_x traps (LNTs), also known as NO_x adsorbers. LNTs appear to be favored by light-duty manufacturers (as witnessed by Honda's announcement of their intent to use them with their CIDI engines in 2009) since overall fuel efficiency is less of a concern than for heavy-duty manufacturers, and because urea replenishment represents a larger concern for light-duty customers than for heavy-duty vehicle users. LNTs appear to be able to achieve the Tier 2 Bin 5 light-duty vehicle emission levels when new using ultra-low-sulfur fuel, although full-useful-vehicle-life emissions have not yet been demonstrated. Other drawbacks to LNT use on heavy-duty vehicles are that they are larger in relation to engine displacement (being over twice as large as those required for light-duty vehicles), the "not-to-exceed" operating conditions generate higher exhaust temperatures which degrade durability, and the fuel used for regeneration adds to operating costs. Research on LNTs has decreased this fuel "penalty," but it is still in the range of five to ten percent of total fuel flow. This problem is exacerbated by the need to periodically drive off accumulated sulfur (even using ultra-low-sulfur fuel) by heating the adsorber to high temperatures, again by using fuel (desulfation). In addition, the high temperature of regeneration and desulfation has been shown to cause deterioration in catalyst effectiveness. LNTs additionally require substantial quantities of platinum group metals (PGM), and the cost of these materials has been rising at a concerning rate.

An optimum solution to CIDI engine emissions would be to alter the combustion process in ways that produce emissions at levels that don't need ancillary devices for emissions control, or greatly reduce the requirements of these systems, yet maintain or increase engine efficiency. This is the concept behind new combustion regimes such as homogeneous charge compression ignition (HCCI), pre-mixed charge compression ignition (PCCI) and modes of low-temperature combustion (LTC), which result in greatly reduced levels of NO_x and PM emissions (emissions of hydrocarbons and carbon monoxide still exist and must also be controlled – the lower exhaust temperatures associated with these combustion modes can make hydrocarbon and carbon monoxide control difficult). Significant progress is being made in these types of combustion systems, and performance has been demonstrated over increasingly larger portions of the engine speed/load map. In recent years, DOE has adopted the term "high-efficiency clean combustion" (HECC) to include these various combustion modes since the boundaries among them are difficult to define. The major issues of this R&D include fuel mixing, control of air intake flow and its temperature, control of combustion initiation, and application over a wider portion of the engine operating range. Control of valve opening independent of piston movement appears to be highly desirable for such engines. Most heavy-duty engine manufacturers are employing some sort of HECC in engines designed to meet the 2010 emission standards, and Ford has announced that it intends to release a light-duty CIDI engine employing HECC before 2012 which may not include any NO_x aftertreatment devices.¹

Complex and precise engine and emission controls will require sophisticated feedback systems employing new types of sensors. NO_x and PM sensors are in the early stages of development and require additional advances to be cost-effective and reliable, but are essential to control systems for these advanced engine/aftertreatment systems. Much progress has been made, but durability and cost

¹"Ford, PSA Developing HCCI Diesel" by William Diem, WardsAuto.com, Oct. 11, 2006.

remain as the primary issues with these sensors. Start-of-combustion sensors have been identified as a need, and several development projects have been started.

Advanced fuel formulations and fuel quality are also crucial to achieving higher energy efficiencies and meeting emissions targets. The EPA rule mandating that the sulfur content of highway diesel fuel be reduced to less than 15 ppm is a great benefit to the effectiveness, efficiency, and durability of emission control devices. Since October 15, 2006, diesel fuel being sold for highway use in most of the country has less than 15 ppm sulfur (complete phase-in is anticipated by 2010 as small refiner exemptions are phased out). The addition of non-petroleum components such as biodiesel can have beneficial effects on emissions while providing lubricity enhancement to ultra-low-sulfur diesel fuel. Recent tests have shown that biodiesel lowers the regeneration temperature of particulate traps and increases the rate of regeneration with the potential for avoiding or reducing the need for active regeneration and its associated fuel economy penalty. On the other hand, biodiesel use has resulted in some operational problems as well. Fuel filter plugging has been reported under cold conditions for fuels with as little as 2% biodiesel because the biodiesel was not made to specification for blending with diesel fuel. Biodiesel is certain to become more prevalent in diesel fuel due in part to the recent expansion of the Renewable Fuel Standard, which calls for 7.5 billion gallons of renewable fuel (mostly ethanol) to be used in transportation fuels by 2012.

Waste heat recovery represents an area of significant potential for efficiency improvements. Testing has shown that waste heat recovery has the potential to improve vehicle fuel economy by 10% and heavy-duty engine efficiency also by 10%.

Future Directions

Internal combustion engines have a maximum theoretical fuel conversion efficiency that is similar to that of fuel cells; it approaches 100%. The primary limiting factors to approaching these theoretical limits of conversion efficiency start with the high irreversibility in traditional premixed or diffusion flames, but include heat losses during combustion/expansion, untapped exhaust energy, and mechanical friction. Multiple studies agree that combustion irreversibility losses consume more than 20% of the available fuel energy and are a direct result of flame front combustion. Analyses of how “new combustion regimes” might impact the irreversibility losses have indicated a few directions of moderate reduction of this loss mechanism, but converting the preserved availability to work will require compound cycles or similar measures of exhaust energy utilization. The engine hardware changes needed to execute these advanced combustion regimes include variable fuel injection geometries, turbo and super charging to produce very high manifold pressures, compound compression and expansion cycles, variable compression ratio, and improved sensors and control methods. Larger reductions in combustion irreversibility will require a substantial departure from today’s processes but are being examined as a long-range strategy.

The other areas where there is large potential for improvements in internal combustion engine efficiency are losses from the exhaust gases and heat transfer losses. Exhaust losses are being addressed by analysis and development of compound compression and expansion cycles achieved by valve timing, use of turbine expanders, regenerative heat recovery, and application of thermoelectric generators. Employing such cycles and devices has been shown to have the potential to increase heavy-duty engine efficiency by 10% to as high as 55%, and light-duty vehicle fuel economy by 10%. Heat transfer losses may be reduced by HECC, and interest in finding effective thermal barriers remains valid.

Fuels can also play an important role in reducing combustion irreversibility losses. Preliminary analyses show that combustion irreversibility losses per mole of fuel are considerably less for hydrogen than for hydrocarbon fuels. This finding is consistent with the understanding that combustion irreversibility losses are reduced when combustion is occurring nearer equilibrium (high temperature), since hydrogen has the highest adiabatic flame temperature of the fuels studied to date. This bodes well for the development of highly efficient hydrogen-fueled internal combustion engines.

Emission control devices for CIDI engines to reduce PM and NO_x will become widespread over the next few years. Much work still needs to be done to make these devices more durable and to lessen their impact on fuel consumption. Information about how best to employ these emission control devices also continues to evolve with new developments leading to more efficient operation. As engine combustion becomes cleaner, the requirements of the emission control devices will change as well with increased attention to CO and HC control.

Goals and Challenges

The Advanced Combustion Engine R&D Sub-Program has four activities:

- Combustion and Emission Control R&D
- Heavy Truck Engine R&D
- Waste Heat Recovery
- Health Impacts

Combustion and Emission Control R&D

The Combustion and Emission Control R&D activity focuses on enabling technologies for energy-efficient, clean vehicles powered by advanced internal combustion engines (ICEs) using clean hydrocarbon-based and non-petroleum-based fuels and hydrogen. R&D has been focused on developing technologies for light-, medium-, and heavy-duty CIDI engines and is being transitioned to developing technologies for advanced engines operating in combustion regimes that will further increase efficiency and reduce emissions to near-zero levels.

Fuel efficiency improvement is the overarching focus of this activity, but resolving the interdependent emissions challenges is a critical integrated requirement. (Penetration of even current-technology CIDI engines into the light-duty truck market would reduce fuel use by 30-40% per gasoline vehicle replaced.) The major challenges facing CIDI emission control systems across all three platforms are similar: durability, cost, and fuel penalty (or in the case of urea-SCR, urea infrastructure development). Full-life durability in full-scale systems suitable for 2010 regulations has yet to be demonstrated for either light- or heavy-duty systems.

The FreedomCAR and Fuel Partnership technical targets for ICEs are shown in Table 1. The following goals are energy-efficiency improvement targets for advanced combustion engines suitable for passenger cars and light trucks; they also address technology barriers and R&D needs that are common between light- and heavy-duty vehicle applications of advanced combustion engines.

- By 2007, achieve peak engine efficiency of at least 42% and, combined with some emission control devices, meet EPA Tier 2, Bin 5 requirements in a light-duty vehicle using diesel fuel (specified by the Fuels Technology Sub-Program) with a fuel efficiency penalty of not more than 2%.
- By 2010, develop the understanding of novel low-temperature combustion regimes needed to simultaneously enable engine efficiency of 45% with a fuel penalty of less than 1%.
- By 2015, lower the cost of hydrogen ICEs to \$30/kW.

Heavy Truck Engine R&D

The long-term (2013) goal of this activity is to develop the technologies that will increase the thermal efficiency of heavy-duty diesel engines to at least 55% while reducing emissions to near-zero levels. More specifically,

- By 2006, increase the peak thermal efficiency of heavy-duty engines to 50% while meeting EPA 2010 emission standards.
- By 2013, increase the peak thermal efficiency of heavy truck engines to 55% while meeting prevailing EPA emission standards.

The interim goal for FY 2006 of achieving 50% efficiency while demonstrating 2010 emission standards was successfully achieved. This activity also supports the goal of the 21st Century Truck Partnership to develop and validate a commercially viable, 50%-efficient, emissions-compliant engine system for Class 7 and 8 highway trucks by 2010.

TABLE 1. Technical Targets for the Combustion and Emission Control Activity

Characteristics	Units	Fiscal Year			
		2007	2009	2010	2015
FreedomCAR Goals, ICE Powertrain					
Peak brake thermal efficiency (HC fuel) (H ₂ fuel)	%			45 45	45
Cost (HC fuel) (H ₂ fuel)	\$/kW			30 45	30
Reference peak brake thermal efficiency ^a	%	32	34	35	
Target peak brake thermal efficiency/part-load brake thermal efficiency (2 bar BMEP ^b @1500 rpm)	%	42/29	44/30	45/31	
Powertrain cost ^{c,d}	\$/kW	30	30	30	
Emissions ^e	(g/mile)	Tier 2, Bin 5	Tier 2, Bin 5	Tier 2, Bin 5	
Durability ^e	Hrs.	5,000	5,000	5,000	
Thermal efficiency penalty due To emission control devices ^f	(%)	<3	<1	<1	

^a Current production, EPA compliant engine

^b Brake mean effective pressure

^c High-volume production: 500,000 units per year

^d Constant out-year cost targets reflect the objective of maintaining powertrain (engine, transmission, and emission control system) system cost while increasing complexity.

^e Projected full-useful-life emissions for a passenger car/light truck using advanced petroleum-based fuels as measured over the Federal Test Procedure as used for certification in those years.

^f Energy used in the form of reductants derived from the fuel, electricity for heating and operation of the devices, and other factors such as increased exhaust back-pressure, reduce engine efficiency. A cycle average thermal efficiency loss of 1 to 2% is equivalent to a 3 to 5% fuel economy loss over the combined Federal Test Procedure drive cycle.

As seen in Table 2, researchers will need to increase thermal efficiency of heavy-duty truck engines significantly while maintaining low emissions by the end of 2013. To date, all the 2006 targets have been achieved. Further increases in engine efficiency will be needed to achieve the interim efficiency objectives for 2009 and 2013.

TABLE 2. Technical Targets for Heavy Truck Diesel Engine R&D

Characteristics	Fiscal Year			
	2006 Status	2006	2009	2013
Engine thermal efficiency, %	50	50	51	55
NO _x emissions, g/bhp-hr	<0.20	<0.20	<0.20	<0.20
PM emissions, g/bhp-hr	<0.01	<0.01	<0.01	<0.01
Stage of Development	prototype	prototype	prototype	prototype

Waste Heat Recovery

Recovery of waste energy from the engine exhaust represents a potential for 10% or more improvement in overall engine thermal efficiency. Turbochargers strongly influence engine efficiency in several ways, including recovery of part of the exhaust energy. Turbochargers currently have

efficiencies of around 50 to 58%, which could be increased to 72 to 76% with enhancements such as variable geometry. Turbocompounding can be configured to produce mechanical shaft power or electric power for additional waste heat recovery. Direct thermal-to-electric conversion could also improve the overall thermal efficiency. Bulk semiconductor thermoelectric devices are currently 6 to 8% efficient. Recent developments in quantum well thermoelectrics suggest a potential improvement to over 20% is possible. A Rankine bottoming cycle for heat recovery is being used in one of the heavy truck engine efficiency projects.

The longer-term goal of this activity is to develop the technologies for recovering engine waste heat and converting it to useful energy that will improve overall diesel engine thermal efficiency to 55% while reducing emissions to near-zero levels. More specifically,

- By 2012, enable commercially viable turbocompound units that can produce up to 40 kW of additional power from heavy-duty engine waste heat recovery.
- By 2012, achieve at least 21% efficiency in quantum well thermoelectric devices for waste heat recovery.

This activity also supports the overall engine efficiency goals of the FreedomCAR and Fuel Partnership and the 21st Century Truck Partnership.

The technical targets for the waste heat recovery R&D activities are listed in Table 3. Significant progress will be needed to meet the 2008 targets. Ongoing and newly awarded projects are focused on achieving this progress.

TABLE 3. Technical Targets for Waste Heat Recovery

Characteristics	Units	Fiscal Year		
		2006 Status	2008	2010
Turbocompound system				
Class 7-8 trucks				
Fuel economy improvement	%	<5	>5	>10
Power	kW	>10	>20	>40
Projected component life	Hrs.	<10	>5,000	>10,000
Thermoelectric Devices				
Efficiency	%			
bulk semiconductor		6-8	--	--
quantum well		--	>15	>20
Projected cost/output (250,000 production volume)	\$/kW	TBD	500	180

Health Impacts

The FCVT Program and its industry partners are on the leading edge in the technology development of future technologies to improve fuel economy and enable the use of non-petroleum-based fuels in passenger and commercial vehicles. The Health Impacts Research activity performs the critical role of elevating potential health issues related to these future technologies to the attention of industry partners and DOE/FCVT management. This activity ensures that the development of new vehicle technologies, rather than just enabling compliance with existing standards, also considers the possibility of causing negative health impacts.

The goals of the Health Impacts Research activity are as follows:

- Provide a sound scientific basis underlying any unanticipated potential health hazards associated with the use of new powertrain technologies, fuels, and lubricants in transportation vehicles.
- Ensure that vehicle technologies being developed by FCVT for commercialization by industry will not have adverse impacts on human health through exposure to toxic particles, gases, and other compounds generated by these technologies.

Project Highlights

The following projects highlight progress made in the Advanced Combustion Engine R&D Sub-Program during FY 2006.

Advanced Combustion and Emission Control Research for High-Efficiency Engines

A. Combustion and Related In-Cylinder Processes

The objective of these projects is to identify how to achieve more efficient combustion with reduced emissions from advanced technology engines.

- Argonne National Laboratory (ANL) made the first-ever X-ray measurements of CIDI fuel injector sprays at an ambient pressure of 30 bar which is representative of the ambient density inside a turbocharged light-duty diesel engine at the start of injection.
- Sandia National Laboratories (SNL) identified the existence of a toroidal vortex at the exit of re-entrant bowl CIDI combustion chambers, and the role of this vortex in trapping soot and unburned hydrocarbons. The vortex also prevents mixing of combustion products exiting the bowl with additional squish volume oxidizer.
- SNL studied spray, combustion, and pollutant formation for two conventional and three low-temperature combustion conditions and developed an optical diagnostic technique to identify sources of unburned fuel emissions.
- SNL demonstrated that fuel changes (e.g., oxygenation) can lead to the production of soot with a disordered nanostructure that could oxidize up to five times faster than highly ordered soot from conventional diesel fuel. They also showed that while neat biodiesel can lower smoke emissions by ~50% relative to conventional diesel fuel when high levels of cooled exhaust gas recirculation (EGR) are used, further reductions of at least an order of magnitude are required to meet the 2010 PM emission target without using aftertreatment.
- SNL generated unique datasets for *in situ* soot volume fraction in reacting sprays as a function of EGR level, ambient temperature, ambient density, injection pressure, and fuel type. They also found that reduced soot formation using extensive EGR is caused by soot kinetics rather than mixture equivalence ratio.
- Oak Ridge National Laboratory (ORNL) expanded the speed-load range of operation under high-efficiency clean-combustion (HECC) using combinations of high- and low-pressure EGR methods. They also characterized the potential emissions reduction of using fuel injectors with reduced orifice diameters for improved atomization and mixing.
- ORNL achieved and demonstrated the 2007 FreedomCAR goal of 41% peak brake thermal efficiency in an automotive-size diesel engine and validated the part-load efficiency target.

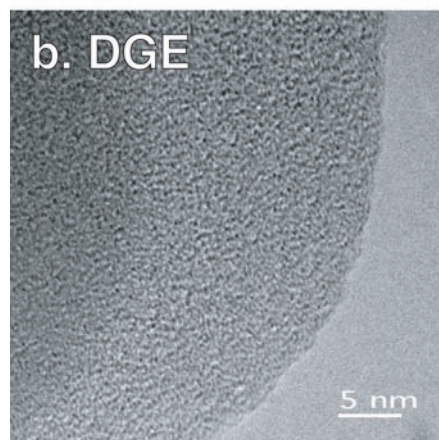
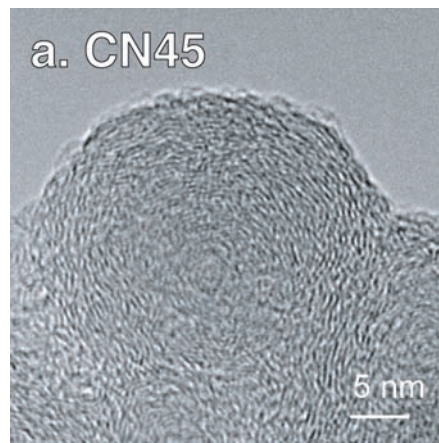

High resolution transmission electron micrographs of soot from a) a hydrocarbon reference fuel and b) a fuel blend with the oxygenate diethylene glycol diethyl ether. SNL found that the highly disordered nanostructure of soot from the oxygenated fuel is correlated with oxidation rates up to five times greater than those for soot with a more-orderly nanostructure.

- SNL conducted a suite of validation studies aimed at simultaneous treatment of turbulence and combustion phenomena in internal combustion engine environments. They also established the “Computational Combustion and Chemistry Laboratory” specifically dedicated to internal combustion engine calculations.
- Lawrence Livermore National Laboratory (LLNL) developed a very fast methodology for analysis of HCCI combustion - only ~10% longer computational time than a motored (non-firing) case. They also demonstrated innovative control strategies and applied them to the Caterpillar 3406 experimental HCCI engine, demonstrating accurate cylinder balancing and fast load and ignition timing adjustment.
- SNL found that the HCCI combustion process consists of a series of distinct phases, each with its own unique chemiluminescence spectral and spatial signature, indicating different key reactions. They also determined that chemiluminescence intensity tracks the heat-release rate well during the main high-temperature combustion for higher fueling rates, but it is not a reliable marker of the heat-release rate at low loads.
- SNL uncovered correlation between laser-induced fluorescence based probability density function statistics of fuel-air mixing and measured engine-out NO_x emissions during low-load, late-injection HCCI operation. Taken together with earlier data for carbon-based emissions, these results indicate that the developed probability density function method could be a useful tool for formulating and assessing advanced mixture-preparation strategies.
- Los Alamos National Laboratory (LANL) completed the parallelization of KIVA-4, which reduces computational time by a factor of 3.2 using a moving square bowl grid. KIVA-4 was tested against several analytical solutions, and the results, along with KIVA-4’s numerical algorithms, are to appear in the Journal of Computational Physics.
- LLNL completed models for chemical kinetics of combustion of three major fuel components, plus methyl cyclohexane, and di-isobutylene. They continued development of surrogate mixtures to describe HCCI ignition.
- SNL established collaborative modeling research with the University of Michigan and General Motors to simulate a full hybrid vehicle platform powered by a free-piston engine.
- ANL obtained endoscope images at over 2,000 RPM and over 6 bar indicated mean effective pressure (IMEP) for port fuel injection, single injection direct injection, and double injection direct injection of hydrogen. OH* chemiluminescence images were obtained using ultraviolet imaging, showing the progression of the combustion event. A correlation between heat release and OH* intensity was obtained.
- SNL measured flame front propagation speeds for hydrogen injection prior to intake valve closure at various equivalence ratios. They also found an empirical correlation between OH* chemiluminescence emission intensity and equivalence ratio that is used to obtain a semi-quantitative measure of the maximum in-cylinder equivalence ratio.
- Cummins has demonstrated 6% improvement in fuel economy relative to the baseline value with preliminary steady-state multi-cylinder engine testing optimized for premixed charge compression ignition (PCCI) combustion.

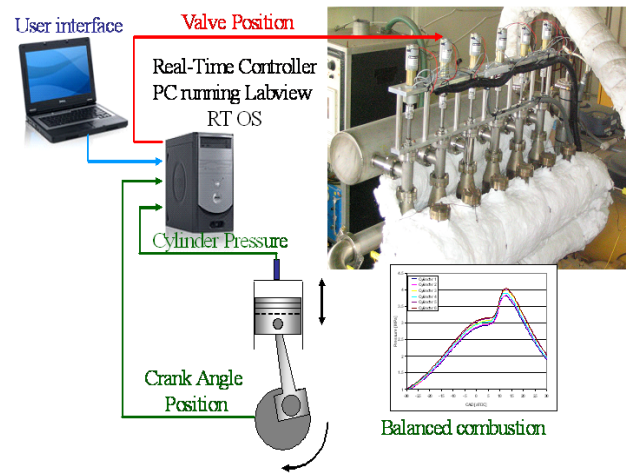

HCCI Control System Developed by LLNL for Experimental Caterpillar 3406 HCCI Engine

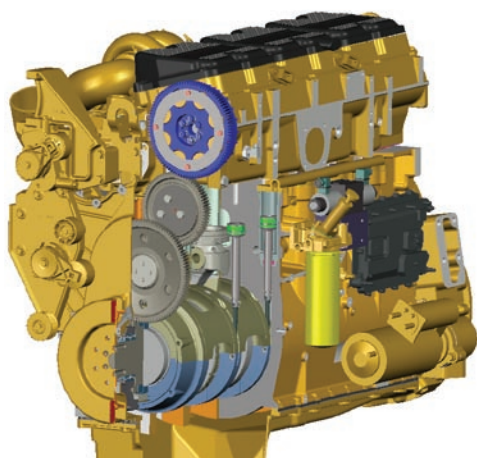

Cross-Section of Caterpillar Variable Compression Ratio Engine

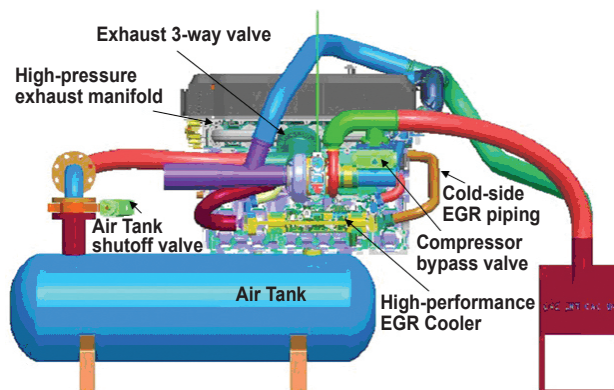

Compressed Air Hybrid System Developed by Mack Trucks

- Caterpillar developed an advanced multi-cylinder engine with compression ratio flexibility and tested it, demonstrating benefits for emissions, efficiency and controls.
- International Truck and Engine redesigned their ITEC 6.4L V8 to support low-temperature or HCCI combustion for high efficiency and low emissions, targeting 2010 federal emission standards using standard diesel fuel.
- John Deere demonstrated that an advanced diesel engine can be operated at stoichiometric conditions with reasonable particulate and NO_x emissions at full power and peak torque conditions. Such an engine does not need EGR and will operate at 42% brake thermal efficiency without advanced hardware, turbocompounding, or waste heat recovery.
- Mack Trucks completed a vehicle simulation using air-power-assist (APA) engine technology that showed 4–18% efficiency improvement over a wide range of driving cycles. In addition, they found that low-temperature EGR offered an additional 3-4% efficiency improvement in vehicle simulation tests.
- General Motors completed set up of both gasoline and diesel engines with variable valve actuation systems to enable and test HCCI combustion.

B. Energy-Efficient Emission Controls

The following project highlights summarize the advancements made in emission control technologies to both reduce emissions and reduce the energy needed for emission control system operation.

- SNL found an optimized, thermodynamically consistent set of kinetic parameters for the regeneration mechanism of lean-NO_x traps by fitting model predictions to the results of pseudo-steady-state reactor experiments conducted at ORNL.
- ORNL identified multiple sulfate species on both Ba- and K-based lean-NO_x traps that are dependent on time and temperature and demonstrated linear loss in storage sites with sulfation.
- ORNL quantified details of CO regeneration of lean-NO_x traps and the function of the water-gas-shift reaction and characterized detection limit of various analytical methodologies for real-time on-engine measurement of oil dilution.
- ORNL achieved interim Tier 4 NO_x emissions and final Tier 4 PM emissions for an off-highway diesel engine using a combination of advanced injection control coupled with urea-SCR. This represents a >90% reduction in NO_x and PM emissions over the baseline setting.

- ORNL found that when evaluating a lean-NOx trap with low reductant concentrations, the NOx conversion was 11–33% higher at all temperatures with hydrogen engine exhaust compared to conventional CIDI exhaust.
- Pacific Northwest National Laboratory (PNNL) developed tools for digital reconstruction of three-dimensional particulate filter substrate microstructures from a small set of two-dimensional images. They added soot oxidation kinetics to the micro-scale lattice-Boltzmann filter model and developed techniques for observing regeneration on the surface of uncatalyzed and platinum-catalyzed single-channel filter samples.
- ORNL held the 9th Cross-Cut Lean Exhaust Emissions Reduction Simulations (CLEERS) workshop at University of Michigan, Dearborn on May 2–4.
- ORNL continued testing and validation of the LNT material characterization protocol in conjunction with the LNT Focus Group, SNL, PNNL and collaborating suppliers, and initiated diffuse reflectance infrared Fourier-transform spectroscopy (DRIFTS) measurements of Umicore reference catalyst to study the relationship of sulfur poisoning to multiple storage sites.
- ORNL modified LNT regeneration strategies to generate engine-out hydrogen and other reformat products under net-lean conditions and tested them on commercial SCR catalysts using hydrocarbons as the reductant.
- General Motors developed a microwave heating technique that uniformly heats a diesel particulate filter for regeneration and eliminates parasitic soot absorption.
- General Motors tested over 5,600 materials for NOx reduction potential and achieved conversion efficiencies of 92% (Highway Cycle), 76% (US06 Cycle) and 60% (Federal Test Procedure, FTP) using a V6 common rail diesel. Sulfur poisoning has been evaluated, and regeneration strategies have been identified using both reactor studies and engine evaluations.

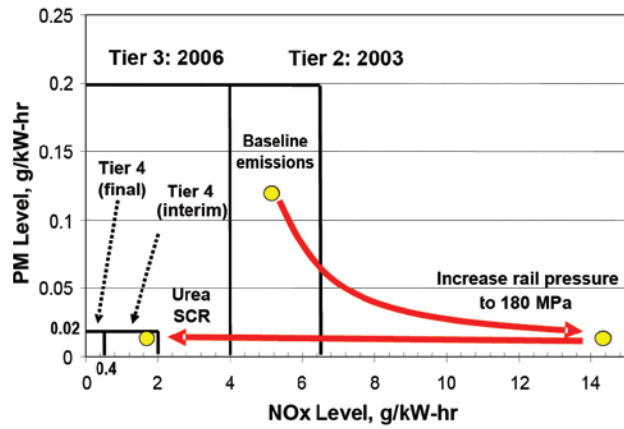

Pathway to Lower Off-Highway Engine Emissions Developed by ORNL

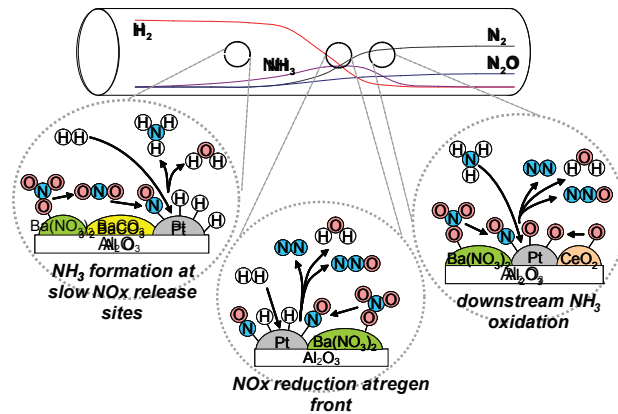

Scenario proposed by ORNL for the stages involved in LNT regeneration as the reductant front progresses axially down the monolith

C. Critical Enabling Technologies

Variable valve actuation and variable compression ratio systems are enabling technologies for achieving more efficient engines with very low emissions. The following highlights show the progress made during FY 2006.

- Envera reduced the hydraulic pressures in their variable compression ratio actuator system by 86% through system optimization.
- Delphi Automotive Systems completed the engine evaluation matrix and selected the diesel engine to be used for testing of their variable valve actuation system. More than 100 research papers were studied and three potential valve motion solutions were identified.

Heavy Truck Engine

With the advent of stringent emission standards, it is necessary to design engines as systems to achieve both high efficiency and low emissions. The following project highlights describe the progress made for both light- and heavy-duty engines during FY 2006.

- Cummins demonstrated 50% brake thermal efficiency from a heavy-duty diesel engine while meeting 2010 U.S. EPA legislated emissions requirements.
- Detroit Diesel Corporation demonstrated integrated experimental and analytical technologies capable of achieving 50.2% thermal efficiency at EPA-regulated 2010 emissions levels at a single operating condition in a multi-cylinder engine configuration.

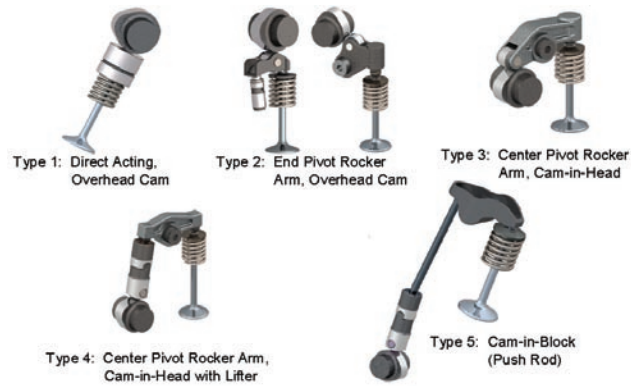

Different Valve System Types Investigated by General Motors for Variable Valve Actuation Systems

Waste Heat Recovery

Several technologies are being pursued to capture waste heat from advanced combustion engines, including electricity generation from turbochargers, thermoelectrics, and compound/bottoming cycles. Following are highlights of the development of these technologies during FY 2006.

- General Motors achieved a ZT value of 1.3 at 800 K in nano-composite n-type skutterudites, the highest reported ZT values for n-type skutterudite thermoelectric materials.
- BSST has modeled and designed 20-watt high temperature and 750-watt low temperature thermoelectric generators. A vehicle performance model used to predict fuel efficiency has been developed and validated, and fuel efficiency improvement ranging up to 7.7% has been predicted.
- United Technologies Corporation developed a new thermoelectric generator design that resulted in a 6.5–7.0% fuel economy improvement versus the earlier reported 4–4.5%. A series of bulk boron carbide nanocomposites was fabricated and characterized, and thermoelectric property measurements were acquired up to 400°C.
- Michigan State University measured properties of known materials for the temperature range of operation and estimated that a segmented couple can provide a 12.3% conversion efficiency. Calculations show estimated improvement of up to 6.2% in fuel economy for a Class 8 truck operating at cruise conditions.
- Cummins has designed and is testing a Rankine cycle to extract waste heat from a heavy-duty truck engine. Recovered waste heat energy will be converted to electricity to assist in driving the vehicle, and powering electrically driven parasitics (such as coolant pumps, fans, etc.) will be explored in addition.

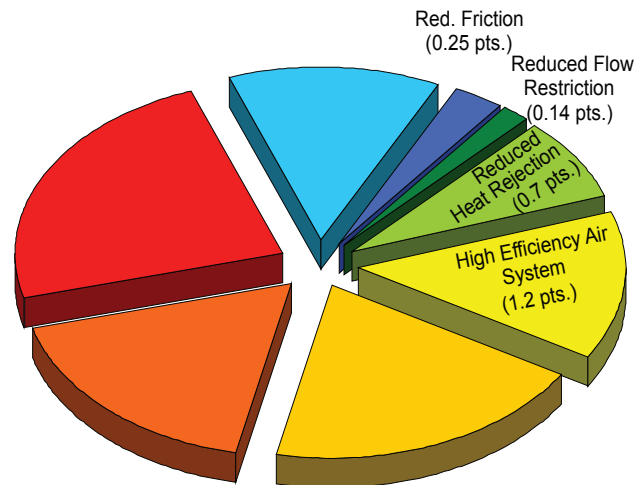

Contribution of 50% Thermal Efficiency Building Blocks Developed by Caterpillar

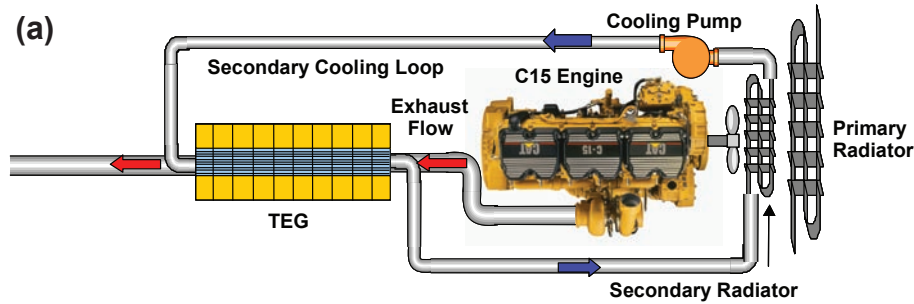

System-Level Thermoelectric Generator Design Developed by United Technologies

- Mack Trucks demonstrated through simulation an engine efficiency increase of 8.2% through use of a continuously variable transmission when operating over a road cycle and 10.5% during steady-state operation at U.S. 2010 NO_x levels (0.2 g/bhp-hr).

Off-Highway Engine Efficiency R&D

Off-highway vehicles are coming under more stringent emission controls similar to those for highway vehicles. However, their typical duty cycles place unique demands on emission control systems. Following are highlights of off-highway vehicle emission control development during FY 2006.

- John Deere completed models that accurately predicted the pressure drop across both a diesel oxidation catalyst (DOC) and a DOC plus a catalyzed particulate filter (DOC+CPF) for various engine speeds and loads under steady-state operation. The models also accurately predicted the amount of mass deposited and oxidized in the CPF as a function of time. The models will next be tested to see if they can indicate when to regenerate.
- In a Cooperative Research and Development Agreement (CRADA) with John Deere, ORNL discovered that the total PM emissions were reduced by 50% by the urea-SCR catalyst in a system without a DPF. This effect was maintained during high rates of urea application.
- John Deere developed and tested a compact 50 kW flywheel-mounted motor/generator system. Through component optimization and turbo system matching, performance goals of 20% power growth and a 10% increase in fuel economy have been demonstrated at Tier 3 emissions levels.

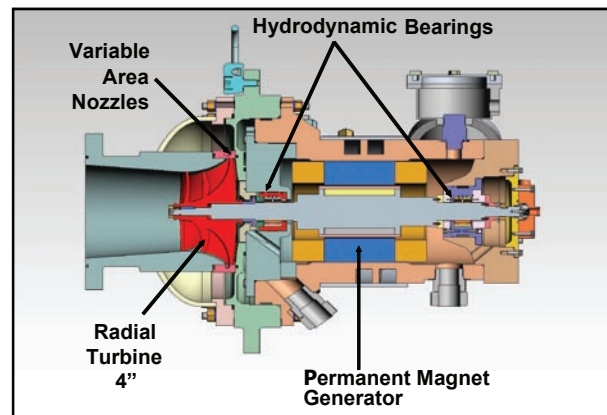

Cummins Proposed Turbine/Generator Design

Health Impacts

The Health Impacts activity studies potential health issues related to new powertrain technologies, fuels, and lubricants to ensure that they will not have adverse impacts on human health. Following are highlights of the work conducted in FY 2006.

- ORNL completed a project concentrating on ambient air quality which showed that idling trucks typically dominate the air quality degradation near the roadway despite the large number of trucks traveling on the road per day.

- Lovelace Respiratory Research Institute discovered that used diesel crankcase oil nanoparticles have low lung toxicity, completed a comprehensive study of the effects of repeated inhalation exposure to laboratory-generated gasoline emissions, and discovered that non-particulate emissions from gasoline engines can cause vascular changes in a mouse model of atherosclerosis.
- The Health Effects Institute is utilizing established emissions characterization and toxicological test methods to assess the overall safety of production-intent engine and control technology combinations that will be introduced into the market during the 2007–2010 time period.



UV Remote Sensing Technique Developed by ORNL

University Research

- The University of Wisconsin-Madison has formulated combustion models and reaction mechanisms and applied them to analyze low-emissions operation. A low-emissions window of operation has been identified as a benchmark for further testing.
- West Virginia University developed two models as comparative tools for diesel and low-temperature combustion. The low-temperature combustion model allows for prediction of auto-ignition onset. A general friction model was chosen that includes losses from piston-ring assembly, engine bearing, valvetrain and engine auxiliaries.
- The University of Houston obtained time-averaged NOx conversions exceeding 80% in a lean-NOx trap with cycling protocols of 60 second storage phase and 5–10 second regeneration phase. The byproduct ammonia and nitrous oxide selectivities were determined, with ammonia selectivity as high as 50% depending on the rich pulse composition.
- The University of Kentucky Center for Applied Energy Research determined the effect of ceria on lean-NOx trap NOx storage and regeneration behavior by means of powder reactor and DRIFTS measurements.
- Texas A&M University completed and documented a parametric study of the destruction of availability during the combustion process for simple systems. The availability destroyed during the combustion process decreased with increasing temperatures and varied with the fuel being used under constant conditions.

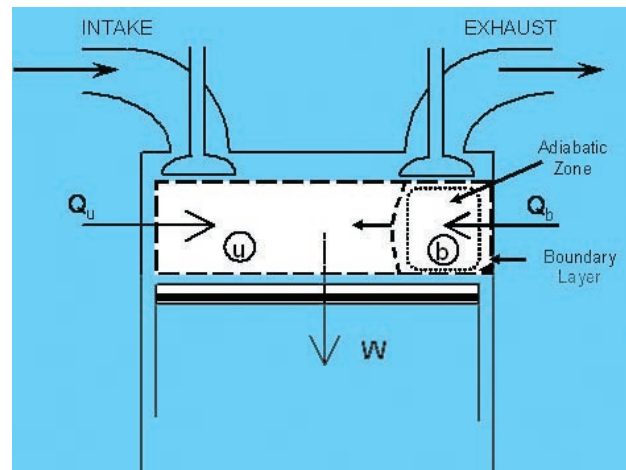

Texas A&M Engine Cylinder Schematic Depicting Three Zones During Combustion

- The University of Michigan has shown through engine testing and modeling that pilot injection of fuel during negative valve overlap (NVO) can be used to extend the lower load limit of homogeneous charge compression ignition (HCCI) operation. They also found that spark assist has a stabilizing effect on combustion under limiting conditions.

Future Directions

Advanced Combustion and Emission Control Research for High-Efficiency Engines

A. Combustion and Related In-Cylinder Processes

The focus in FY 2007 for combustion and related in-cylinder processes will continue to be on advancing the fundamental understanding of combustion processes in support of achieving efficiency and emissions goals. This will be accomplished through modeling of combustion, in-cylinder observation using optical and other imaging techniques, and parametric studies of engine operating conditions. Several labs and universities plan to adopt a common engine research platform that will span optical single-cylinder through multicylinder experiments. Achievement of 42% peak efficiency for the 2007 FreedomCAR goal is expected to be validated at ORNL with this engine.

In FY 2007, LANL will continue their efforts to integrate advanced combustion models into the KIVA-4 computational fluid dynamics model and implement grid converters to improve its accuracy in unstructured grids. LANL will validate their customized version of KIVA against experimental data from both SNL and ORNL for engine operation under HCCI and PCCI conditions. One of their objectives is to develop their model as a predictive tool for engine geometry and fuel injection optimization. SNL will continue to work towards their objective to use high-fidelity science-based simulations in a manner that directly complements select optical engine experiments also being conducted by SNL. The simulations will be carried out using a highly specialized state-of-the-art flow solver designed for turbulent reacting multiphase flows and will be used to study hydrogen combustion. LLNL will extend their fuel combustion model capabilities to additional classes of fuel components, including biodiesel and larger hydrocarbon components, to investigate the effect of fuel molecular structure on sooting under diesel engine conditions.

ANL is continuing their efforts to increase the ambient pressure in their X-ray fuel injector spray measurement device to more closely simulate actual fuel injection pressures. They also plan to incorporate faster data acquisition, processing, and analysis; improved X-ray detector systems; increased X-ray intensity; and greater automation. ANL will also use their endoscope imaging system to acquire images of OH* chemiluminescence from a direct injection hydrogen engine with the objective of characterizing a multiple injection strategy to improve performance while minimizing emissions. This work will be complemented by SNL using planar laser induced fluorescence (PLIF) to obtain a spatially resolved quantitative measure of in-cylinder equivalence ratio. SNL will also apply PLIF imaging to a comparative study of mixture formation using two different gasoline direct injection (GDI) fuel injectors for stratified-charge operation, as well as to a complete investigation of how HCCI progresses through the combustion event, using chemiluminescence spectroscopy and chemical-kinetic analysis for single- and two-stage-ignition fuels. Additional activities at SNL in FY 2007 include evaluating low-temperature combustion, exploring the effects of fuel properties on soot and NO_x formation, and studying the effect of fuel spray penetration and equivalence ratio on emissions, all using in-cylinder laser optical techniques.

ORNL will be using parametric engine studies in FY 2007 to resolve multi-cylinder stability and control issues for expanded high-efficiency, controlled combustion (HECC) engine operation. They will also employ combustion and engine models to explain the governing processes that occur during transitions between spark ignition and HCCI combustion using gasoline (i.e., physics, chemistry), explore advanced combustion approaches for achieving improved efficiency and reduced emissions, and investigate potential of waste heat recovery strategies. Cummins plans to complete their multi-cylinder

demonstration of premixed charge compression ignition combustion by employing next-generation turbochargers and controls. They also plan to test biodiesel and conduct single-cylinder engine studies of advanced, multi-pulse injection systems. Caterpillar plans to continue their optical engine tests to refine and validate their computational fluid dynamics submodels to implement HECC on advanced multi-cylinder engines. International Truck and Engine plans to implement variable valve actuation hardware with cylinder pressure feedback software and demonstrate 2010 emissions targets under steady-state at target engine operating points. After proving that their stoichiometric compression ignition concept is viable, in FY 2007 John Deere will further test the concept by building a complete system. Mack Trucks will continue development of their concept to use the engine to convert braking energy into compressed air stored in an on-board tank which is subsequently used to partially power the engine without combustion using a unique variable valve actuation system. SNL plans to initiate design, fabrication, and construction of a two-stroke opposed piston prototype utilizing optimized coupling of Magnequech alternators as a proof-of-concept tool.

General Motors will test variable valve actuation systems on both single- and multi-cylinder engines and assess the potential to lower NO_x emissions to meet the Tier 2 Bin 5 standard without the use of aftertreatment devices.

B. Energy-Efficient Emission Controls

In FY 2007, work will continue on lean-NO_x traps (LNTs) and selective catalytic reduction using urea (urea-SCR) to reduce NO_x emissions. The focus of activities will be on making these devices more efficient, more durable, and less costly. For particulate matter (PM) control, the focus will be on more efficient methods of filter regeneration to reduce impact on engine fuel consumption.

In FY 2007, PNNL will continue fundamental studies of NO_x adsorber materials, including BaO morphology studies using temperature programmed X-ray diffraction at the National Synchrotron Light Source and *in situ* transmission electron spectroscopy studies to watch morphology changes in real time. They also will explore the mechanisms of sulfur poisoning of NO_x adsorber materials through refining function-specific measures of 'aging' and continuing to improve mechanistic understanding of sulfur removal processes by identifying important desulfation intermediates and the effects of sulfur concentration on Pt accessibility and barium phase changes.

During FY 2007, SNL plans to continue development of their chemical kinetics models for LNTs by augmenting the regeneration mechanism with reactions for additional kinds of reductants, in particular hydrocarbons; repeat the mechanism assembly and parameter optimization process for the NO_x storage phase of normal LNT operation; and introduce reactions needed to describe sulfur poisoning and desulfation.

In their CRADA with International Truck and Engine, ORNL plans to continue studying LNT chemistry to improve understanding of sulfation/desulfation and will install a camless engine to explore the interaction between advanced low-temperature combustion modes (lower NO_x and PM) and overexpansion (improved efficiency). ORNL also plans to study the fundamental chemistry of LNT sulfation to identify where sulfates form and how best to remove them without damaging the LNT catalyst. In a CRADA with Cummins, ORNL plans to continue evaluation of a range of analytical approaches to assess their applicability for *in situ* oil dilution (caused by operation at certain low-temperature combustion conditions) measurement. ORNL will also, in a CRADA with John Deere, conduct an investigation of particulate formation and chemistry as a function of rail pressure and urea-SCR dosing, optimize the efficiency of a 2007 Deere diesel engine while operating in advanced combustion regimes, assess waste heat recovery potential, and install and evaluate a prototype reformer for a LNT study on the 2007 Deere engine.

While combustion of hydrogen does not result in HCs or CO, it can result in NO_x emissions. In FY 2007, ORNL will explore the use of LNTs and urea-SCR catalysts to control NO_x emissions. They plan to investigate NO:NO₂ ratios and conduct tests at various temperatures and space velocities.

As part of their CLEERS activities, PNNL plans to extend their micro-scale regeneration model to allow studies of phenomena such as 'NOx recycle' and optimization of catalyst loading and placement, and include coupled heat transfer and oxidation exotherms, allowing studies of 'light-off' conditions during active filter regeneration. They also plan to conduct single-channel experiments with catalyzed and uncatalyzed samples in parallel in order to better quantify the effect of catalyst loading on regeneration behavior.

As part of their CLEERS activities, ORNL plans to continue assisting in refinement of CLEERS technical priorities, especially in regard to the balance between LNT and urea-SCR R&D and synergies between these two technology areas. ORNL will organize the 10th CLEERS workshop in the spring of 2007. ORNL also plans to update and post revised global LNT models with input from experimental data as these become available, continue identification of synergies between LNT NH₃ generation kinetics and NH₃-SCR as a potential alternative to urea-SCR NOx control, and coordinate bench reactor studies of the impact of sulfation and desulfation on LNT durability and kinetics.

ORNL plans to evaluate commercial HC-SCR catalysts using bench reactor experiments and tests on an engine dyno. The objective of the bench reactor experiments will be to evaluate the promotional effect of hydrogen, perform temperature sweeps, and investigate CO or HC masking of the catalysts. The engine tests will be used to evaluate high-efficiency clean combustion operation, late-cycle post injection or in-pipe injection of fuel, and individual cylinder control for their effects on HC-SCR catalyst regeneration.

General Motors will examine an alternative diesel particulate filter regeneration technique which builds off the knowledge gained from their microwave regeneration work and may provide an economy benefit over it.

C. Critical Enabling Technologies

The critical enabling technologies activities in FY 2007 include work on variable valve actuation and variable compression ratio systems. In FY 2006, Delphi completed a benchmarking study on competing variable valve actuation (VVA) technologies, prepared a system requirements document, and submitted provisional patent applications covering the VVA mechanism. In FY 2007, Delphi plans to evaluate new dual cam designs, develop detailed packaging designs, and demonstrate and document the performance of the VVA mechanism to enable low-temperature combustion control in CIDI engines. Also in FY 2007, Envera will optimize their variable valve actuator control system, install it in a mule vehicle, and test it.

Waste Heat Recovery

Research will continue in FY 2007 on thermoelectrics and bottoming cycles for capturing and utilizing waste heat from advanced combustion engines. Research on both technologies will focus on development of practical systems that are suitable for future production.

General Motors plans to optimize cost-effective bulk materials, finalize selection of thermoelectric materials for exhaust and radiator heat recovery devices, finalize design of exhaust and radiator waste heat recovery devices including estimated performance, and identify volume-capable and cost-effective manufacturing processes for thermoelectric modules. BSST plans to develop improved low-resistivity electrical contacts to enable weight and cost reductions needed for the target vehicle application; accelerate building of a 750-watt thermoelectric generator module using high-efficiency high-temperature materials; and build a tabletop power generator that displays real-time performance, including energy conversion efficiency. The University of Michigan is planning to conduct design and analysis of the power conditioning system to optimize thermoelectric system performance; explore leg fabrication methods for improving mechanical properties and microstructural characteristics; develop fabrication techniques for scaleable couple/thermoelectric modules; improve results of analytical studies on the full engine system by coupling current simulations to the 3-D heat transfer studies performed at Iowa State University; and improve the coefficient of performance (ZT) by exploring several more promising thermoelectric material compositions.

In the coming year, Cummins will continue development of an effective and efficient Rankine cycle waste heat recovery system by creating specifications for prototype hardware and control software; performing subcomponent testing of prototypes and model-based simulation of integrated systems for vehicle-level performance; defining expected hardware performance in-vehicle; and starting laboratory-based, integrated system testing. Mack Trucks plans to update the design of the compressor and two turbines of their turbocompound system, test the compressor and turbines in special rigs, build prototype high-efficiency turbo and turbocompound units for testing, begin baseline engine development that will include high-efficiency turbo and turbocompound units, and demonstrate the engine and continuously variable transmission system in a test cell environment to determine system efficiency.

John Deere plans to test vehicles under realistic operating cycles to document real-world benefits in both fuel economy and vehicle productivity. They will also develop second-generation hardware with improved performance and greater commercialization potential, define optimal system architecture and power splits for Tier 4 emissions compatibility, and increase the scope of application of turbocompounding by evaluating performance enhancements in both larger and smaller engine platforms. This will be done by starting with modeling to define the potential and then adapting existing hardware to verify advantages.

Health Impacts

The focus of the activities in Health Impacts is to identify and quantify the health hazards associated with exhaust from advanced combustion engines and put them in proper context with other air quality hazards, and to assess the relative hazards of emissions from different fuel, engine, and emission reduction technologies.

In FY 2007, the Lovelace Respiratory Research Institute will complete their work to clarify the health importance of nanoparticle (<50 nm) components of diesel emissions and the relative importance of black carbon- vs. non-solid condensate-based particles; complete their study testing the hypothesis that artifactual formation of nitro-aromatic compounds on filter samples is responsible for much of the mutagenicity of diesel particle extracts; and complete their analysis and publication of results from study of gasoline emissions and comparison to effects of diesel emissions. The Advanced Collaborative Emissions Study (ACES) will initiate their effort to characterize the emissions and assess the safety of advanced heavy-duty diesel engine and aftertreatment systems and fuels designed to meet the 2007 and 2010 emissions standards. The Health Effects Institute, in coordination with the Coordinating Research Council, manages the ACES and will initiate emissions characterization and health effects assessment, as well as solicit and select shorter-term biological screening study contractors to conduct health effects studies.

ORNL will continue their study of health effects of in-use diesel truck emissions by characterizing mobile source air toxics (MSATs) from advanced engine and aftertreatment systems, measuring MSATs at higher time resolutions in order to understand mobile source impacts, and continuing deployment of the remote sensing instrumentation for evaluation of end-use emissions. NREL plans to complete their proximate ozone modeling study in southeast Michigan to answer the question whether the “weekend ozone” effect observed in California also exists in other parts of the country.

University Research

In FY 2007, our university partners will continue their fundamental research into combustion and the chemistry of emission control devices.

The University of Michigan, in conjunction with the University of California at Berkeley, and the Massachusetts Institute of Technology, will simulate the full range of operation of a dual-mode (spark ignition homogeneous charge compression ignition, SI-HCCI) engine and evaluate the fuel economy implications of various control strategies. They will also carry out single-cylinder investigations of upper load combustion limits with super/turbo charging and fast thermal management of intake temperature.

The University of West Virginia will couple their LNT combustion model with a friction model to better evaluate changes that increase indicated mean effective pressure. They will also add a cooling burden model to evaluate waste energy generation. An experimental engine will be identified and procured to conduct experiments.

The University of Houston plans to carry out a comprehensive mechanistic study of the regeneration of model Pt/Rh/Ba NO_x storage and reduction (NSR) catalysts with hydrogen and CO reductants. They will also evaluate performance of the model NSR catalysts in a bench-scale NO_x trap using synthetic lean-burn exhaust feeds.

The University of Kentucky will evaluate NO_x storage/reduction performance of fresh (de-greened) model catalysts using a bench-scale reactor; perform accelerated aging of model catalysts using repeated sulfation-desulfation cycles in a synthetic gas reactor; and perform *in situ* DRIFTS studies in order to relate reactivity at the catalyst surface to catalyst composition (for both fresh and aged catalysts).

Texas A&M will extend their spark ignition engine cycle simulation to include provisions for compression ignition engines; analyze the effects of compression ratio and expansion ratio on engine performance using both the first and second laws of thermodynamics; and investigate the use of exhaust gas energy recovery options from both the first and second laws of thermodynamics.

Michigan State plans to complete baseline testing of their variable cam timing engine for performance and emissions and will conduct experiments with the advanced low-pressure direct injection engine which features the advanced control systems and infinitely variable valves to demonstrate an expected 15% improvement in fuel economy at road load conditions.

Honors and Special Recognitions

- Paul Miles of SNL was awarded the 2005 SAE Harry L. Horning Memorial Award for best paper related to the mutual adaptation of fuels and engines.
- Paul Miles of SNL was invited to give a keynote lecture titled “Thermo- and Fluid Dynamic Processes in Diesel Engines” (September 2006).
- Paul Miles of SNL was invited to give the keynote lecture at the 2nd International Symposium on Clean, High-Efficiency Combustion in Engines (July 2006).
- Lyle Pickett of SNL received the 2005 SAE Horning Award for best technical paper in engine combustion. One award is given each year out of approximately 2,700 SAE papers (SAE 2005-01-3837).
- Lyle Pickett of SNL received an SAE Excellence in Oral Presentation Award for his outstanding technical paper presentation at the 2005 Powertrain and Fluid Systems Conference in San Antonio, Texas (SAE 2005-01-3843).
- Robert Wagner’s work at ORNL was featured as a DOE FreedomCAR Technical Highlight titled “Demonstrated range expansion and estimated potential FTP benefits of HECC operation.”
- Salvador M. Aceves of LANL was invited to deliver a seminar at the SAE 2006 seminar on HCCI (September 2006) in San Ramon, California.
- John Dec of SNL received the SAE Recognition Award for co-organizing the 3rd annual SAE HCCI Symposium in San Ramon, California (September 2006).
- Magnus Sjöberg of SNL was invited to give a presentation at the SAE HCCI Symposium in San Ramon, California (September 2006).
- John Dec of SNL was an invited member of the Technical Committee for the 2nd International Symposium on “Clean and High-Efficiency Combustion in Engines” in Tianjin, China (2006).
- John Dec received an SAE Excellence in Oral Presentation Award, 2006 SAE Congress.
- Magnus Sjöberg received the SAE Forest R. McFarland Award for efforts and leadership in organizing technical sessions on HCCI combustion.
- Bill Pitz of LLNL received an SAE Oral Presentation Award for “Detailed Chemical Kinetic Modeling of Surrogate Fuels for Gasoline and Application to an HCCI Engine,” 2005 Fall Powertrain and Fluid Systems Conference & Exhibition in San Antonio, Texas.

- Bill Partridge of ORNL was invited to give the presentation “Spatially Resolved Capillary-Inlet Mass Spectrometry: Instrument Details and Applications” to the Centre for the Theory and Application of Catalysis (CenTACat), Queen's University Belfast, Belfast, Ireland (June 2006).
- Mike Harold of the University of Houston had the first prize poster at the Southwest Catalysis Society Symposium (May 2006).
- Jerry Caton of Texas A&M University received an SAE 2005 Excellence in Oral Presentation Award for presentation of “Use of a Cycle Simulation Incorporating the Second Law of Thermodynamics: Results for Spark-Ignition Engines Using Oxygen Enriched Combustion Air” at the 2005 SAE International Congress and Exposition, Society of Automotive Engineers, Cobo Hall, Detroit, Michigan (April 2005).
- Chuck Peden (invited presenter), C.M. Wang, J.H. Kwak, D.H. Kim, J. Szanyi, R. Sharma, and S. Thevuthasan, “In-Situ TEM Study of Morphological Evolution of Emission Control Catalysts During Operation”, presentation at the NSF Workshop on "Dynamic in-situ electron microscopy as a tool to meet the challenges of the nanoworld", Tempe, AZ, January 2006.
- Special recognition for collaborative R&D under CLEERS from USCAR was presented to R. Blint (May 2006).

Invention and Patent Disclosures

- Robert Wagner, ORNL: Patent pending, “Device and Method for Inferring Low Particulate Emissions from Nitrogen Oxide Measurements in Low Temperature Diesel Combustion Processes.”
- Daniel L. Flowers of LANL: Patent awarded, “Controlling and Operating Homogeneous Charge Compression Ignition (HCCI) Engines,” United States Patent 6,923,167, August 2, 2005.
- John Dec, SNL: Patent pending, application #11/095,256, “Fuel Mixture Stratification as a Method for Improving Homogeneous Charge Compression Ignition Engine Operation.”
- Caterpillar patents:
 1. Ignition timing control with fast and slow control loops (IVP and EGR).
 2. Mixed high and low pressure EGR in HCCI engine.
 3. Strategy for extending the HCCI operation range using low cetane number diesel fuel and cylinder deactivation.
 4. Recipe for high load HCCI operation.
 5. Power balancing cylinders in HCCI engine.
- Delphi Automotive Systems provisional patents submitted:
 1. System for Continuously Varying Engine Valve Duration
 2. Continuously Variable Valve Actuation System
- Ja Hun Kwak, Do Heui Kim, Xianqin Wang, Janos Szanyi, and Charles H.F. Peden, PNNL: “New Desulfurization Process for Suppression of Pt Sintering of Sulfated Lean NO_x Traps.” PNNL Invention Disclosure #15330-E, filed in August 2006.
- Robert Wagner, ORNL: Patent pending, “A Method for Diagnosing and Controlling Combustion Instabilities In Internal Combustion Engines Operating in or Transitioning to Homogeneous Charge Compression Ignition Modes,” IDEAS 05-156.
- Ron Graves, Brian West, Shean Huff, and James Parks: Provisional patent filed, “Advanced Engine Management for Control of Exhaust Species,” 3/30/2006.
- Richard Blint, General Motors: five records of invention were filed based on his work to discover NO_x reduction catalysts for CIDI engines.

The remainder of this report highlights progress achieved during FY 2006 under the Advanced Combustion Engine R&D Sub-Program. The following 67 abstracts of industry, university, and national laboratory projects provide an overview of the exciting work being conducted to tackle tough technical challenges associated with R&D of higher efficiency, advanced internal combustion engines for light-

duty, medium-duty, and heavy-duty vehicles. We are encouraged by the technical progress realized under this dynamic Sub-Program in FY 2006, but we also remain cognizant of the significant technical hurdles that lay ahead, especially those to further improve efficiency while meeting the EPA Tier 2 emission standards and heavy-duty engine standards for the full useful life of the vehicles.

Gurpreet Singh

Team Leader,
Advanced Combustion Engine R&D
Office of FreedomCAR and Vehicle
Technologies

Kenneth Howden

Technology Development Manager
Advanced Combustion Engine R&D
Office of FreedomCAR and Vehicle
Technologies

Roland Gravel

Technology Development Manager
Advanced Combustion Engine R&D
Office of FreedomCAR and Vehicle
Technologies

John Fairbanks

Technology Development Manager
Advanced Combustion Engine R&D
Office of FreedomCAR and Vehicle
Technologies

James Eberhardt

Technology Development Manager
Advanced Combustion Engine R&D
Office of FreedomCAR and Vehicle
Technologies

