

ENGINEERING DESIGN FILE

PROJECT NO. 22901

SECONDARY CONTAINMENT AND SUPPORT SKID DESIGN FOR V-TANK CONSOLIDATION TANKS



EDF No.: 5017 EDF Rev. No.: 0 Project File No.: 22901

1. Title: <u>Secondary Containment and Support Skid Design for V-Tank Consolidation Tanks</u>				
2. Index Codes:				
Building/Type	<u>N/A</u>	SSC ID	<u>N/A</u>	Site Area <u>034 (TAN)</u>
3. NPH Performance Category: <u>PC-0</u> or <input type="checkbox"/> N/A				
4. EDF Safety Category: <u>CG</u> or <input type="checkbox"/> N/A SCC Safety Category: <u>CG</u> or <input type="checkbox"/> N/A				
5. Summary: This EDF documents the design calculations for the secondary containment and supporting skid for new consolidation tanks. Contents of the TAN V-tanks will be removed and placed in the new consolidation tanks for subsequent treatment. The proposed location of the consolidation tanks is the area north of building TAN-666. This area will be re-graded and the support skid placed on gravel fill. The calculations include the design of a secondary containment pan, tank shield plates with supporting frame, and tank support skid. Also included in this EDF is an analysis of a V-Tank Mockup platform designed by B. D. Raivo.				
6. Review (R) and Approval (A) and Acceptance (Ac) Signatures: (See instructions for definitions of terms and significance of signatures.)				
	R/A	Typed Name/Organization	Signature	Date
Performer/Author	N/A	R. F. Lippert, P.E. /3K16	<i>R.F. Lippert</i>	8-26-04
Technical Checker	R	D. L. Stephens, P.E. /3K16	<i>D.L. Stephens</i>	8-26-04
Approver	A	V. J. Balls, P.E. /3K16	<i>Vondell Balls</i>	8/26/04
Design Project Engineer	Ac	M. E. Bodily /3K16	<i>Mark E. Bodily</i>	8/26/04
Program Project Engineer	Ac	G. E. McDannel /3CH0	<i>RKF G.E. McDannel</i>	8/30/04
Doc. Control		<i>Becky Metcalf</i>	<i>Becky Metcalf</i>	9-9-04
7. Distribution: (Name and Mail Stop) R. F. Lippert MS 3650, G. E. McDannel MS 9206				
8. Does document contain sensitive unclassified information? <input type="checkbox"/> Yes <input checked="" type="checkbox"/> No If Yes, what category:				
9. Can document be externally distributed? <input checked="" type="checkbox"/> Yes <input type="checkbox"/> No				
10. Uniform File Code: <u>8201</u> Disposition Authority: <u>A17-31-a-1</u> Record Retention Period: <u>Until dismantlement or disposal of facility, equipment, system or process</u>				
11. For QA Records Classification Only: <input type="checkbox"/> Lifetime <input type="checkbox"/> Nonpermanent <input type="checkbox"/> Permanent Item and activity to which the QA Record apply:				
12. NRC related? <input type="checkbox"/> Yes <input checked="" type="checkbox"/> No				
13. Registered Professional Engineer's Stamp (if required)				

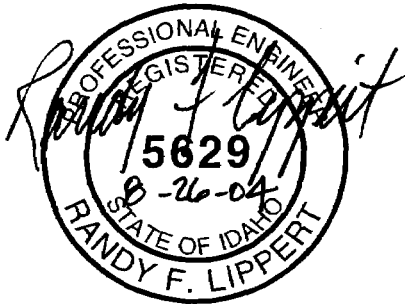

CONTENTS

1.	PURPOSE	3
2.	SCOPE	3
3.	SAFETY CATEGORY	3
4.	NATURAL PHENOMENA.....	3
5.	SYSTEM DESCRIPTION	3
6.	DESIGN AND ANALYSIS.....	4
7.	LOADS	4
8.	ASSUMPTIONS	4
9.	ACCEPTANCE CRITERIA	6
10.	RESULTS	6
11.	REFERENCES.....	6
	Attachment 1, Secondary Containment Pan Design.....	8
	Attachment 2, Tank Shield and Support Frame Design	12
	Attachment 3, Tank Support Frame Design	45
	Attachment 4, Ground Support Evaluation	90
	Attachment 5, Tank Seismic Stability	99
	Attachment 6, V-Tank Mockup Platform Analysis	104
	Attachment 7, Design Drawings.....	131

FIGURES

1.	Consolidation tank layout.....	5
----	--------------------------------	---

Secondary Containment and Support Skid Design for V-Tank Consolidation Tanks

1. PURPOSE

The structural analysis and design contained in this Engineering Design File (EDF) are provided in support of the removal of contents from Technical Support Facility (TSF)-09 Tanks V-1, V-2 and V-3, and TSF-18 Tank V-9. This is the initial phase of the Environmental Remediation of the TAN V-Tanks supporting the Waste Area Group (WAG)-1 Operable Unit (OU) 1-10 remedial action activity. Removal of the V-Tank waste contents is to be accomplished by extracting the liquid and sludge and placing it into new receiving tanks, called "consolidation tanks," to be located in an area north of Building TAN-666.

2. SCOPE

Components of the consolidation tank system include a secondary containment vessel, radiation shielding, and associated support structures. The designs of these components are provided in this EDF.

3. SAFETY CATEGORY

The Safety Category for the V-Tank system is Consumer Grade as defined in TFR-278 (see Reference 1).

4. NATURAL PHENOMENA

The natural phenomena hazards classification for the V-Tanks remedial activity is Performance Category 0 (PC-0) as defined in TFR-278. For PC-0, seismic forces need not be considered.

5. SYSTEM DESCRIPTION

It is proposed to empty the liquid and sludge waste contained in the V-Tanks into three new consolidation tanks that will be located west of the V-tank site in a nearby area north of Building TAN-666. The new tanks are to be identical, each with a capacity of 8,000 gal. The tanks will be cylindrical and supported vertically on legs. Secondary containment must be provided in case of a tank leak. The containment must have a minimum capacity equal to 100% of one of the tanks (8,000 gal) to be in accordance with 40 CFR 264.193 (see Reference 8) as required by TFR-278. A pan constructed from steel plate is designed to provide this containment. To hold 8,000 gal, the pan floor is approximately 21 ft square with a wall height of 3 ft. All three consolidation tanks will sit inside the pan.

Due to the anticipated radiation fields generated from the V-tank waste, shield barriers are required to lower the radiation doses near the tanks to acceptable levels. Concrete blocks, each measuring 2 ft by 2 ft by 6 ft long, will be positioned around the sides of the containment pan as required to accommodate personnel access in the vicinity of the tanks. Since valves and pumps associated with the new consolidation tank system will be located in the containment pan and require access by an operator, additional shielding is required inside the containment pan adjacent to the walls of the tanks. Thick steel plate is to be used for this shielding and will be supported by a structural steel frame. Shielding requirements were based on the calculations of EDF-4604 (see Reference 7).

The area north of Building TAN-666 is currently vacant. The area will need to be cleared of the existing vegetation and have gravel fill in order to support the consolidation tanks. To ensure stable support for the weight of the tanks, containment pan, and shield plates, a steel framed skid is required. The skid will be designed using structural tube members.

A fabric structure will be used as a weather enclosure to house the consolidation tank system.

See Figure 1 for the consolidation tank layout with the secondary containment pan and support skid.

6. DESIGN AND ANALYSIS

The following is a description of the design and analysis calculations included in this EDF:

Attachment 1 contains the design calculations for the secondary containment pan.

Attachment 2 contains the design of the tank shield plates and supporting frame.

Attachment 3 contains the design of the tank support skid (or frame) for distributing the loads from the tanks to the ground.

Attachment 4 contains an evaluation of the ground stability and required gravel fill for supporting the tank skid system.

Attachment 5 contains an evaluation of tank stability considering minimum seismic activity.

Attachment 6 contains an analysis of an access/walkway platform designed for a mockup of the V-tank cleaning operation.

Attachment 7 contains design drawings.

7. LOADS

Only gravity loads are considered in the analysis and design calculations of this EDF. Since the tanks and associated equipment are to be located within an enclosure, wind forces need not be considered. Since the system is considered a PC-0, seismic loading is not applicable.

8. ASSUMPTIONS

The following assumptions are used in the design and analysis calculations:

- The new consolidation tanks will each have four legs.
- The weight of the consolidation tanks is estimated since they have not been purchased at this time.
- The consolidation tanks will be located in an enclosure.

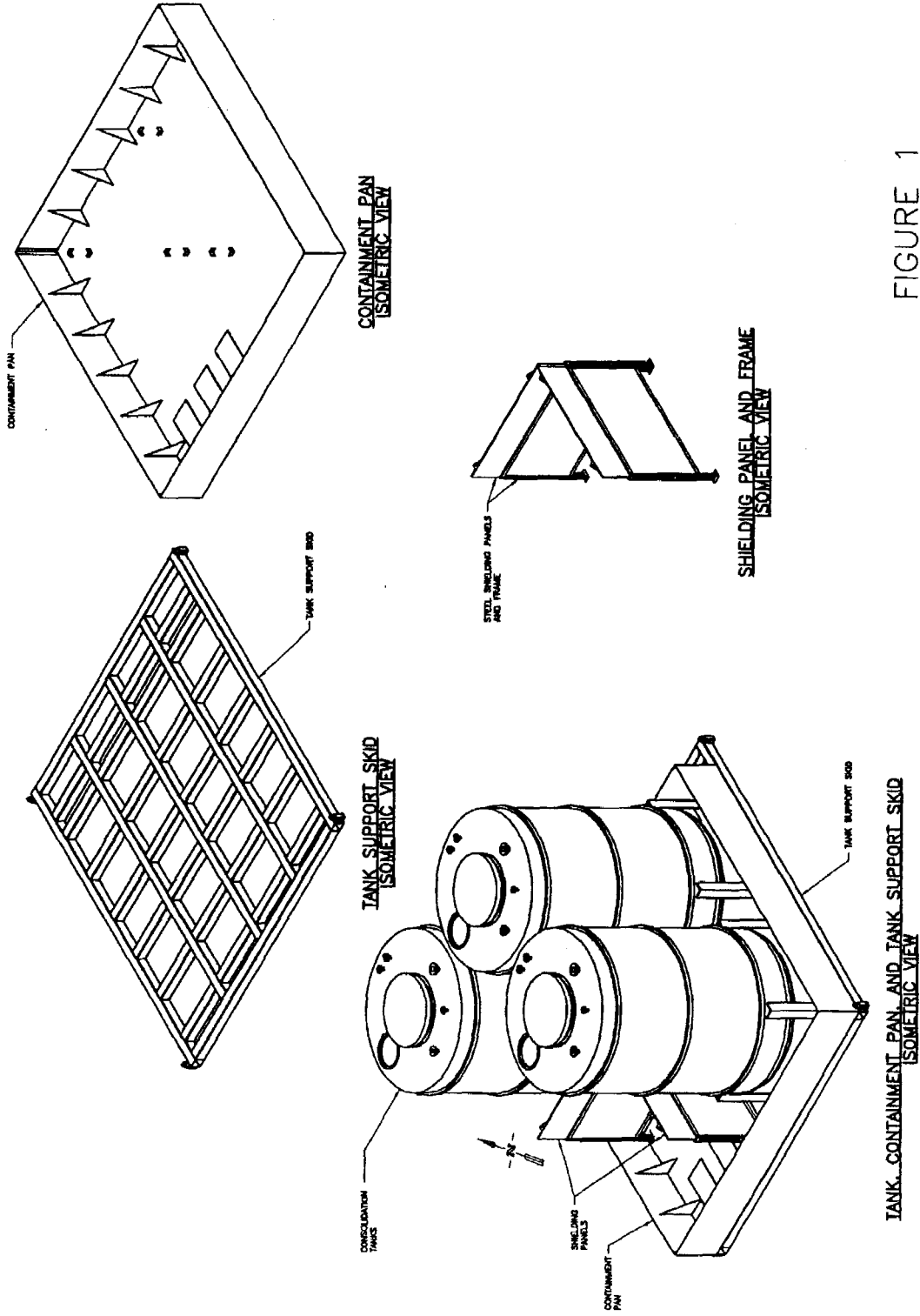

FIGURE 1

Figure 1. Consolidation tank layout.

9. ACCEPTANCE CRITERIA

Structural steel design shall meet AISC criteria for Allowable Stress Design (ASD), (see Reference 2).

10. RESULTS

Attachment 1 contains the design calculations of the containment pan. It will be approximately 21-ft square with walls 3 ft high. It will be constructed from 3/16-in. ASTM A36 carbon steel plate with plate stiffeners placed along the walls.

Steel plates will be positioned near the tanks for radiation shielding. The plates are to be 1-1/4 in. thick (see Reference 7). The design of the frame to support the shielding plates is provided in Attachment 2. The frame consists of $2 \times 2 \times 3/16$ -in. structural tube and is designed to allow the shield plates to slide in and out. Lifting eyes are designed for lifting the plates.

The design of the tank support frame (or skid) is in Attachment 3. The frame is to be constructed using $8 \times 8 \times 1/4$ -in. structural tube. The frame will support the consolidation tanks, the containment pan, and shield plates. Lifting eyes are designed to lift the frame with the pan and shield plate supporting frame (excluding the 1-1/4-in. thick shield plates).

The consolidation tank system will be placed on the ground. Calculations in Attachment 4 indicate that 3 ft of pit run gravel compacted over the existing soil will produce sufficient support for the tanks, maintaining a safety factor of 2.5.

Although a PC-0 is defined for this design, stability of the consolidation tanks is evaluated for minimal seismic loading. Calculations of Attachment 5 determine that the tanks will not tip over when subjected to PC-1 seismic forces. The tip-over safety factor is 2.3.

Included in this EDF is a structural analysis of a platform to be used during a mockup endeavor for demonstrating and verifying V-tank cleaning procedures and activities. Beams and columns for the platform will be structural steel tube, and the deck will be steel grating. The deck will be 12 ft square and stand just under 12 ft high. The analysis, in Attachment 6, indicates that the platform designed by Brian Raivo is more than sufficient to support the anticipated loads.

11. REFERENCES

1. TFR-278, "Technical and Functional Requirements for Tank/Contents Removal and Site Remediation of V-Tanks, TSF-09 and TSF-18, Operable Unit 1-10," Revision 2, June 22, 2004.
2. American Institute of Steel Construction (AISC) Manual of Steel Construction, Allowable Stress Design, 9th Edition, 1989.
3. Roark's Formulas for Stress & Strain, W. C. Young, Sixth Edition, McGraw-Hill, Inc., 1999.
4. Section Maker, Version 8.53, Formation Design Systems, section geometric properties software for the PC platform.
5. ST AAD. Pro, Version 2004, Build 1002, Research Engineers International, structural analysis and design software for the PC platform.

6. RAM Advanse, student version, RAM International, structural analysis and design software for the PC platform.
7. EDF-4604, "Shielding and Exposure Calculations for V-Tank Waste Process Activities," Revision 0, April 19, 2004.
8. 40 CFR 264.193, "Containment and Detection of Leaks," *Code of Federal Regulations*, Office of the Federal Register, June 25, 2004.
9. Design of Welded Structures, O. W. Blodgett, 12th printing, March 1982.
10. DOE-ID Architectural Engineering Standards, Revision 29, U.S. Department of Energy Idaho Operations Office, Idaho Falls, ID, September 12, 2002.
11. Principles of Geotechnical Engineering, B. M. Das, Second Edition, PWS-Kent Publishing Co., 1985.
12. International Building Code, International Code Council, Inc., 2003.

Attachment 1
Secondary Containment Pan Design

SECONDARY CONTAINMENT PAN

A metal pan will be sized to contain the contents of 1 tank, nominal capacity of 8000 gal, for secondary containment; consider floor area of pan to be 21' x 21', min.

$$8000 \text{ gal} = 1069.4 \text{ ft}^3$$

$$\text{pan floor area} = A = 21^2 = 441 \text{ ft}^2$$

$$\text{min. ht of pan} = h = 1069.4/441 = 2.4' \quad \text{say } 3.0' \text{ wall}$$

$$\text{pan vol.} = (21)^2(3) = 1323 \text{ ft}^3 = 9896 \text{ gal}$$

subtract vol. of tank bottoms of 2 non-leaking tanks:

tank bottoms to be dished so conservatively assume ea. tank bott to = vol. of 1 ft depth of tank cyl. (see tank dwg in Att'mt 7)

$$V_d = 2(\pi)(10')^2/4 = 157 \text{ ft}^3 = 1175 \text{ gal}$$

subtract vol of 3 pumps, assume 1' wide x 1' dp x 5' lg for ea. pump:

$$\text{Vol.} = 3(1)(1)(5) = 15 \text{ ft}^3 = 112 \text{ gal.}$$

subtract vol. of piping & other accessories, assume 5 x pump vol.:

$$\text{Vol.} = 5(112) = 560 \text{ gal.}$$

$$\text{Net pan vol.} = 9896 - 1175 - 112 - 560 = 8050 \text{ gal.} \therefore 3' \text{ wall OK}$$

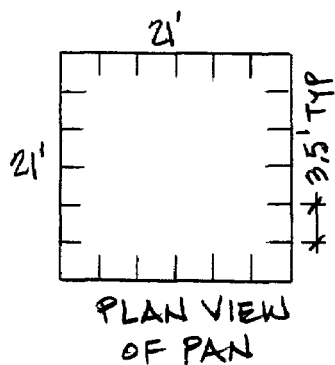
Check Pan For Hydrostatic Loads

use $\#$ stiffeners to reinforce pan walls

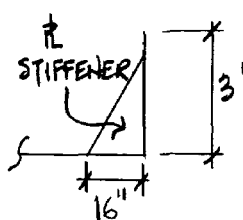

A36 $\#$ for pan & stiffeners

Pan Wall
a

use Reark Table 26
Case 7d (Ref. 3)

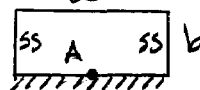

$$a = 3.5' = 42'' \quad t = 0.188''$$

$$b = 3' = 36''$$

$$a/b = 1.17 \therefore \beta = 0.39$$

$$q = 62.4(36)/12^3 = 1.30 \text{ psi/in}$$

$$\text{max } \sigma \text{ (at A)} = \frac{\beta q b^2}{t^2} = \frac{.39(1.3)(36)^2}{(.188)^2} = 18600 \text{ psi} < F_b = .75 F_y = 27000 \text{ psi}$$

Pan Floor

pan will sit on structural framing for support,
assume max. spacing of framing of 5'

USE Roark Table 26 Case 1a (ref. 3)

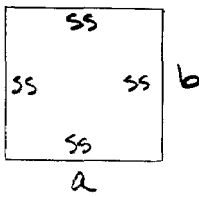

$$a = b = 5' = 60'' \quad t = 0.188''$$

$$q = 1.083 \text{ psi}$$

$$a/b = 1.0 \quad \therefore \beta = 0.2874$$

$$\max \sigma = \frac{\beta q b^2}{t^2} = \frac{0.2874 (1.083) (60)^2}{(0.188)^2} = 31700 \text{ psi} > F_b$$

try $a = 60'' \neq b = 42''$, then $a/b = 1.43 \quad \therefore \beta = 0.463$

$$\max \sigma = \frac{0.463 (1.083) (42)^2}{(0.188)^2} = 25030 \text{ psi} < F_b \quad \text{OK}$$

frame spacing of 3'-6" x 5'-0" is OK

Check Stiffeners

stiffener spacing = $S = 3.5'$

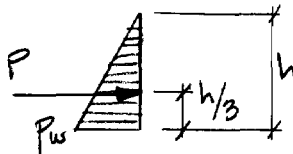

$$h = 3'$$

$$p_w = 62.4 h$$

$$P = \frac{1}{2} p_w h s = \frac{1}{2} (62.4)(3)(3)(3.5) = 983 \#$$

$$M = P \left(\frac{h}{3} \right) = 983 (3)(12)/3 = 11800 \# \text{in}$$

for sect. mod. of stiffener see next pg, $S = 14.9 \text{ in}^3$

$$f_b = \frac{M}{S} = \frac{11800}{14.9} = 792 \text{ psi} \quad \text{very small so OK} \quad (F_y = 36000 \text{ psi})$$

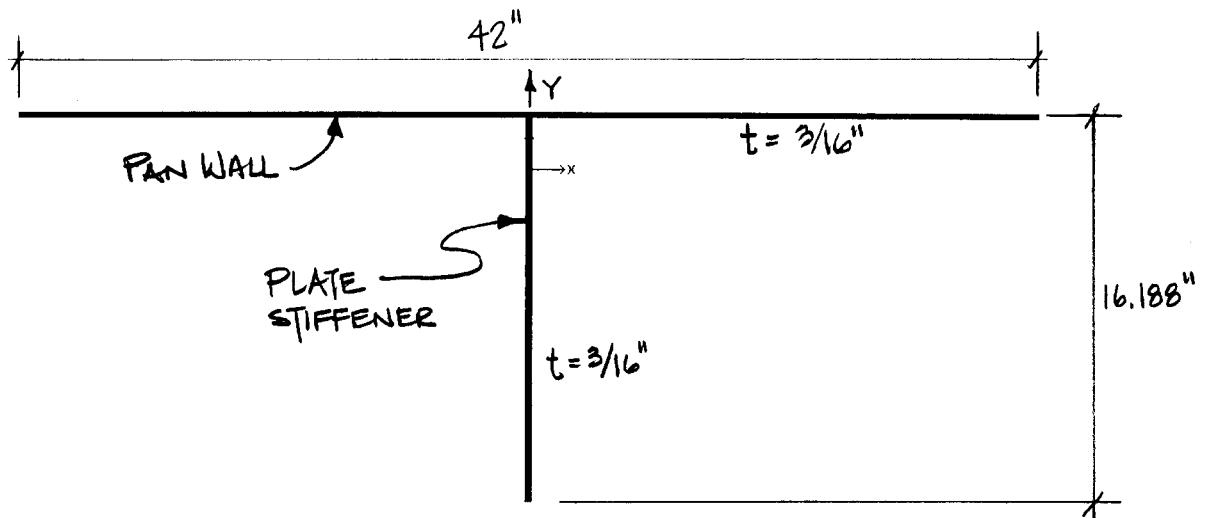

CROSS-SECTION OF PAN WALL & PLATE STIFFENER

Weight	37.104	lb/ft
Area	10.904	in ²
Ix	206.894	in ⁴
Iy	1160.721	in ⁴
J	0.128	in ⁴
E	29000.000	ksi
G	11153.846	ksi
Sxt	88.917	in ³
* Sxb	14.926	in³
Syl	55.272	in ³
Syr	55.272	in ³
rx	4.356	in
ry	10.317	in
Ixc	206.894	in ⁴
Iyc	1160.721	in ⁴
Ixyc	0.000	in ⁴
I1	1160.721	in ⁴
I2	206.894	in ⁴
Ø	-90.000	deg
xc	0.000	in
yc	0.000	in
D	16.188	in
B	42.000	in
tw	0.188	in
tf	0.188	in
xl	-21.000	in
xr	21.000	in
yt	2.327	in
yb	-13.861	in
Asx	7.896	in ²
Asy	3.043	in ²
S1t	55.272	in ³
S1b	55.272	in ³
S2l	88.917	in ³
S2r	14.926	in ³
Fillet Radius	0.000	in
Toe Radius	0.000	in
xs	0.000	in
ys	2.233	in
Perimeter	116.376	in
d1	0.000	in
d2	0.000	in
b1	0.000	in
b2	0.000	in

SECTION MAKER (Ref. 4)

ATTACHMENT 2

Tank Shield and Support Frame Design

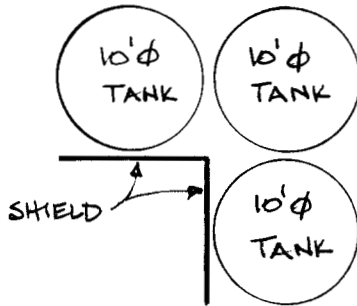
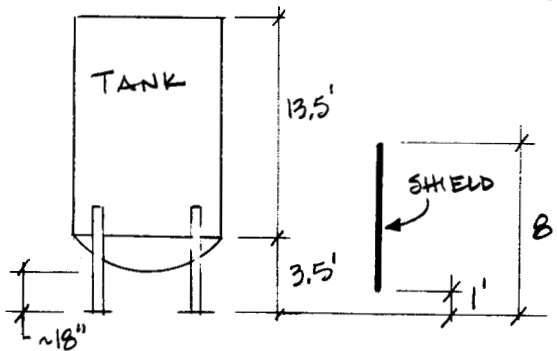
TANK SHIELDPLAN VIEW

shield width = 2 tank dia's = 20'

shield ht \approx 7'

shield area = $A_s = 20(7) = 140 \text{ ft}^2$

Thickness determination for different materials was provided by Robert Miller, see attached dose rate graphs (pgs 16-20).

Steel - req'd thickness = 1.25" $\rho_s = 0.284 \text{ pci}$

unit wt = $1.25(0.284) = 0.354 \text{ psi} = 51.05 \text{ psf}$

steel wt = $51.05(140) = 7150 \#$

Tungsten - req'd thk = 0.44" $\rho_t = 0.697 \text{ pci}$

unit wt = $0.44(0.697) = 0.305 \text{ psi} = 44 \text{ psf}$

tungsten wt = $44(140) = 6160 \#$

Aluminum - req'd thk = 3.5" $\rho_{al} = 0.098 \text{ pci}$

unit wt = $3.5(0.098) = 0.343 \text{ psi} = 49.4 \text{ psf}$

alum wt = $49.4(140) = 6920 \#$

Concrete - req'd thk = 4.125" $\rho_c = 0.0868$ pci
 unit wt = 4.125(0.0868) = 0.358 psi = 51.6 psf
 conc wt = 51.6(140) = 7220#

Lead - req'd thk = 0.625" $\rho_l = 0.41$ pci
 unit wt = 0.625(0.41) = 0.256 psi = 37 psf
 lead wt = 37(140) = 5180#

Based on factors of size, cost, accessibility & disposability, steel ρ will be used for shielding

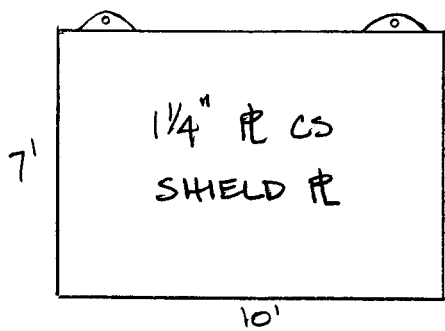

Provide 2 lifting lugs for shield plates.

Provide frame for supporting shield plates near consol. tanks

assume 2 shield ρ 's, ea. 7' x 10'
 ρ wt = 7(10)(51.05) = 3574#

LIFTING LUGS

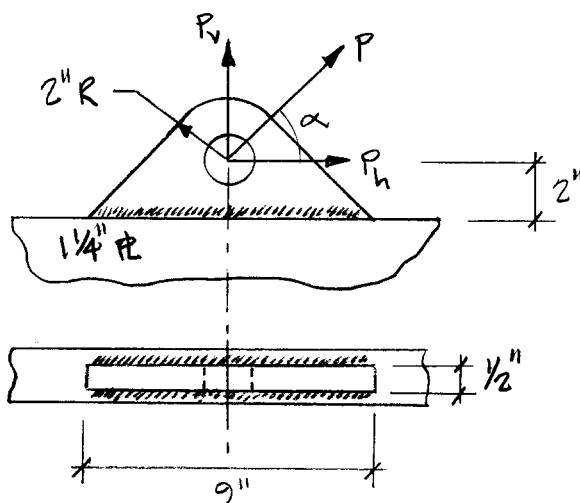

Try 1/2" thk lug w/ 2" hole,
 A36 mat'l

let ea lug support ρ wt
 $P_v = 3574# = 3.6^k$

assume $\alpha = 45^\circ$

$P = 5.1^k \quad \therefore P_h = 3.6^k$

see Ref 2 for AISC references

Check Net Area for Tension

$$F_t = 0.45 F_y = .45(36) = 16.2 \text{ ksi} \quad (\text{AISC D3.1})$$

$$f_t = 5.1 / (.5)(4-2) = 5.1 \text{ ksi} < F_t \quad \text{OK}$$

$$\text{req'd net area} = 5.1 / 16.2 = 0.315 \text{ in}^2$$

Check Area for Brq Shear & Hoop Tension

$$\text{req'd area} = 2/3(0.315) = 0.210 \text{ in}^2 \quad (\text{AISC D3.2})$$

$$\text{net area of } 1/2" \text{ lug} = 0.5(2 - \frac{2}{2}) = 0.5 \text{ in}^2 > 0.21 \text{ in}^2 \quad \text{OK}$$

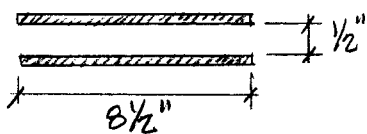
Check Lug Weld

$$A_w = 2(8.5) = 17 \text{ in}^2/\text{in}$$

$$S_w = \frac{d^2}{3} = \frac{8.5^2}{3} = 24.08 \text{ in}^3/\text{in}$$

$$\text{moment on weld} = M = 2.5 P_h = 2.5(3.6) = 9 \text{ k}''$$

$$\text{shear on weld} = V = P_h = 3.6 \text{ k}$$

$$\text{tension on weld} = F = P_v = 3.6 \text{ k}$$

$$\text{tensile stress} = f_t = \frac{F}{A_w} + \frac{M}{S_w} = \frac{3.6}{17} + \frac{9}{24.08} = 0.586 \text{ k/in}$$

$$\text{shear stress} = f_v = \frac{V}{A_w} = \frac{3.6}{17} = 0.212 \text{ k/in}$$

$$f_r = (f_t^2 + f_v^2)^{1/2} = 0.623 \text{ k/in}$$

For E70 weld mat'l, allowable stress on 1" weld is

$$f_a = 0.3(70)(1)(0.707) = 14.8 \text{ k/in}$$

$$\text{req'd weld size} = 0.623 / 14.8 = 0.042" \quad \text{use } 3/16" (0.188) \text{ fillet}$$

EDF-5017

Dose Point @ 3 ft
Fe SHIELD (STEEL)
100 mR/hr @ $\approx 1.25''$

16/138

Robert Miller

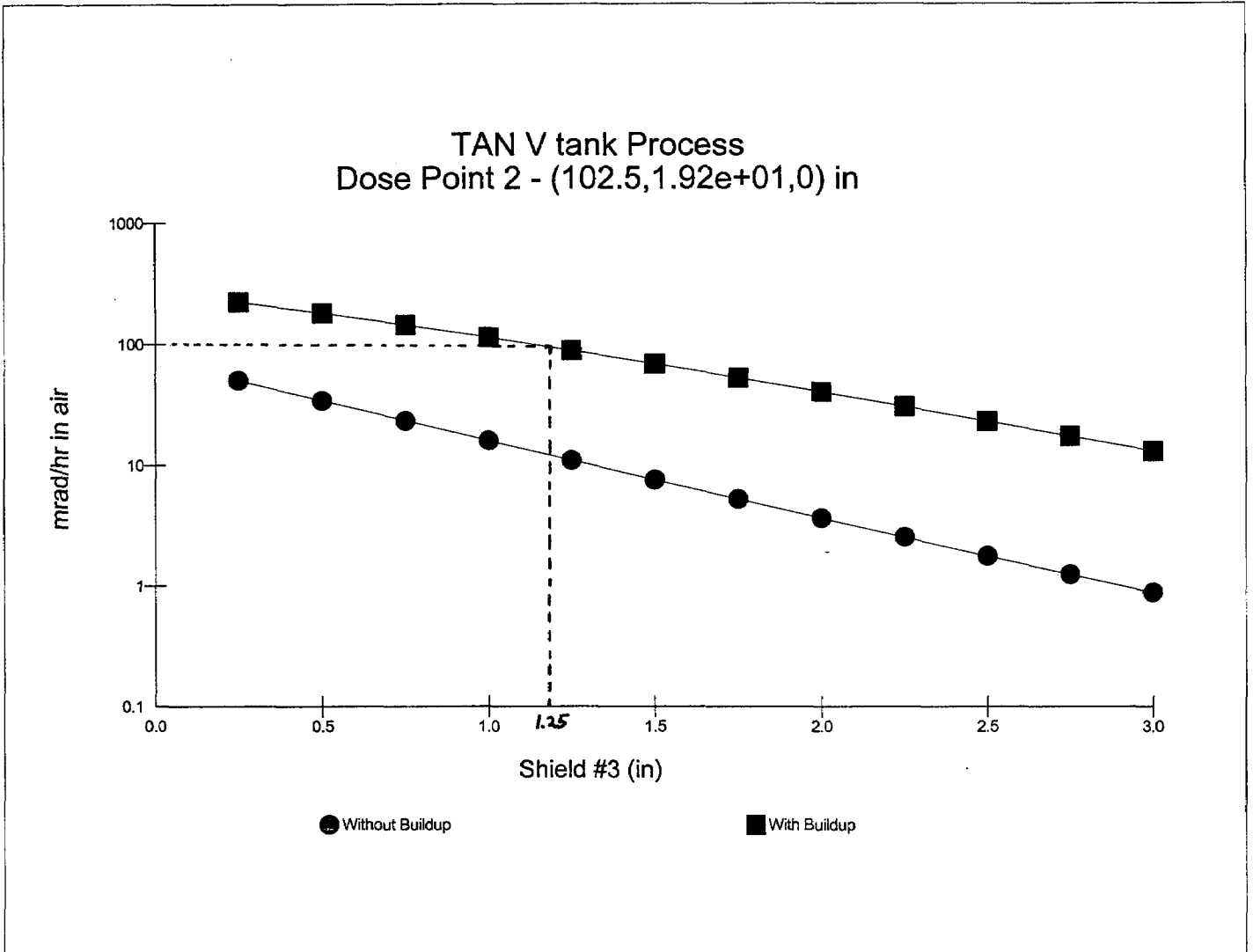

EDF-5017

Dose Point @ 3 ft
W Shield (Tungsten)
100 mR/hr @ $\approx \frac{7}{16}$ "

17/138

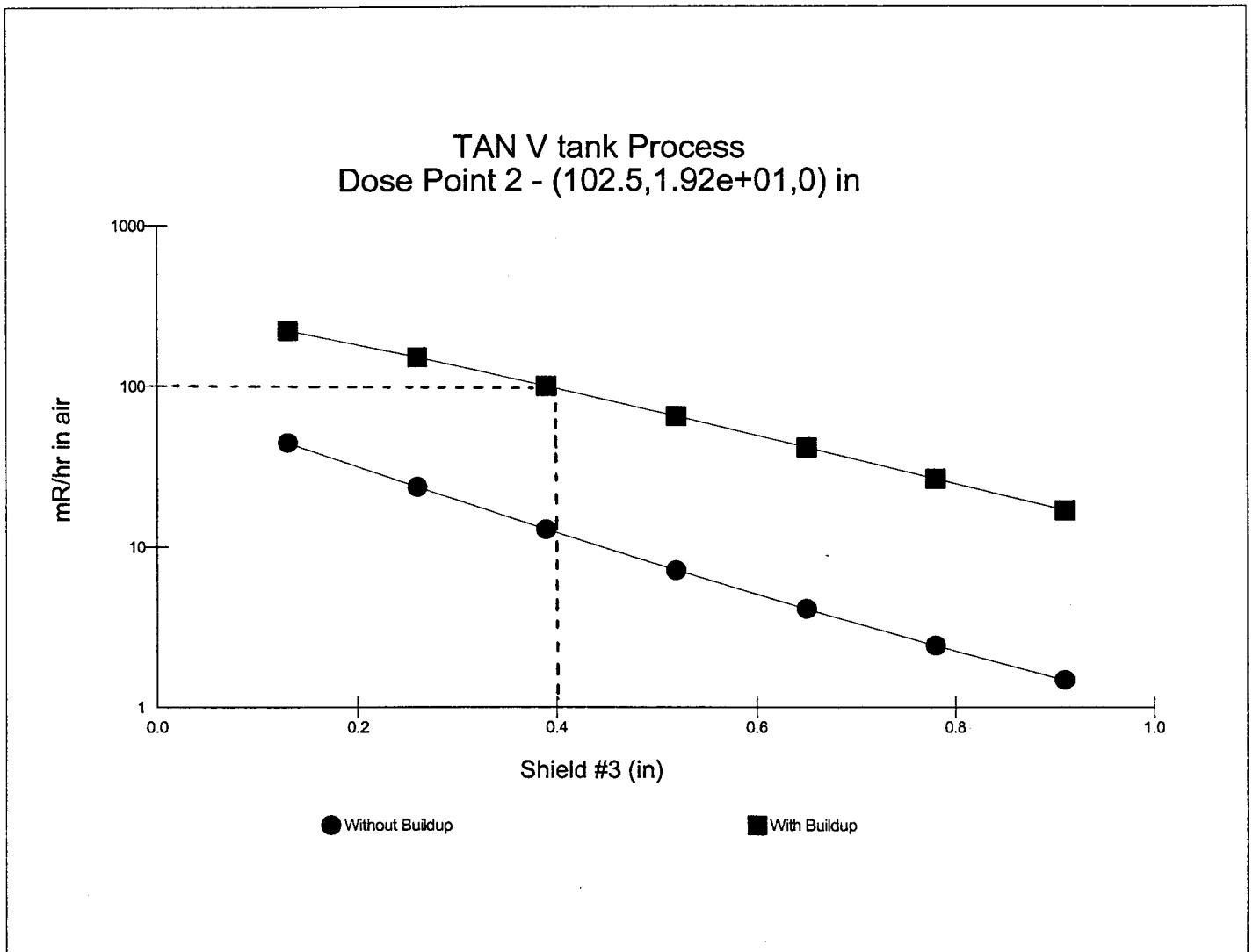

EDF-5017

Dose Point @ 3 ft
Al SHIELD (Aluminum)
100 mR/hr @ ≈ 3.5 "

18/138

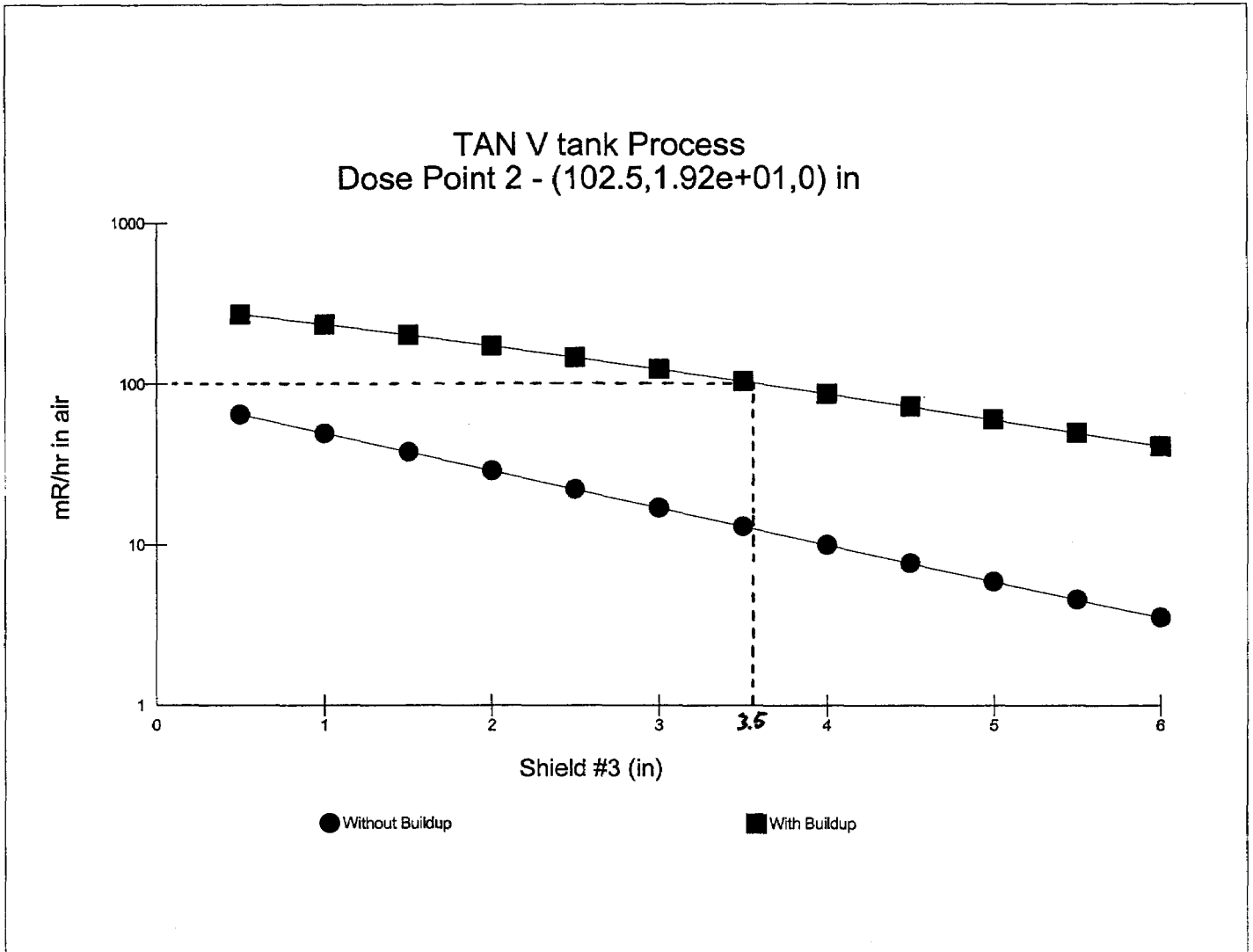

EDF-5017

Dose Point @ 3 ft
CONCRETE SHIELD
100 mR/hr @ $\approx 4.125''$

19/138

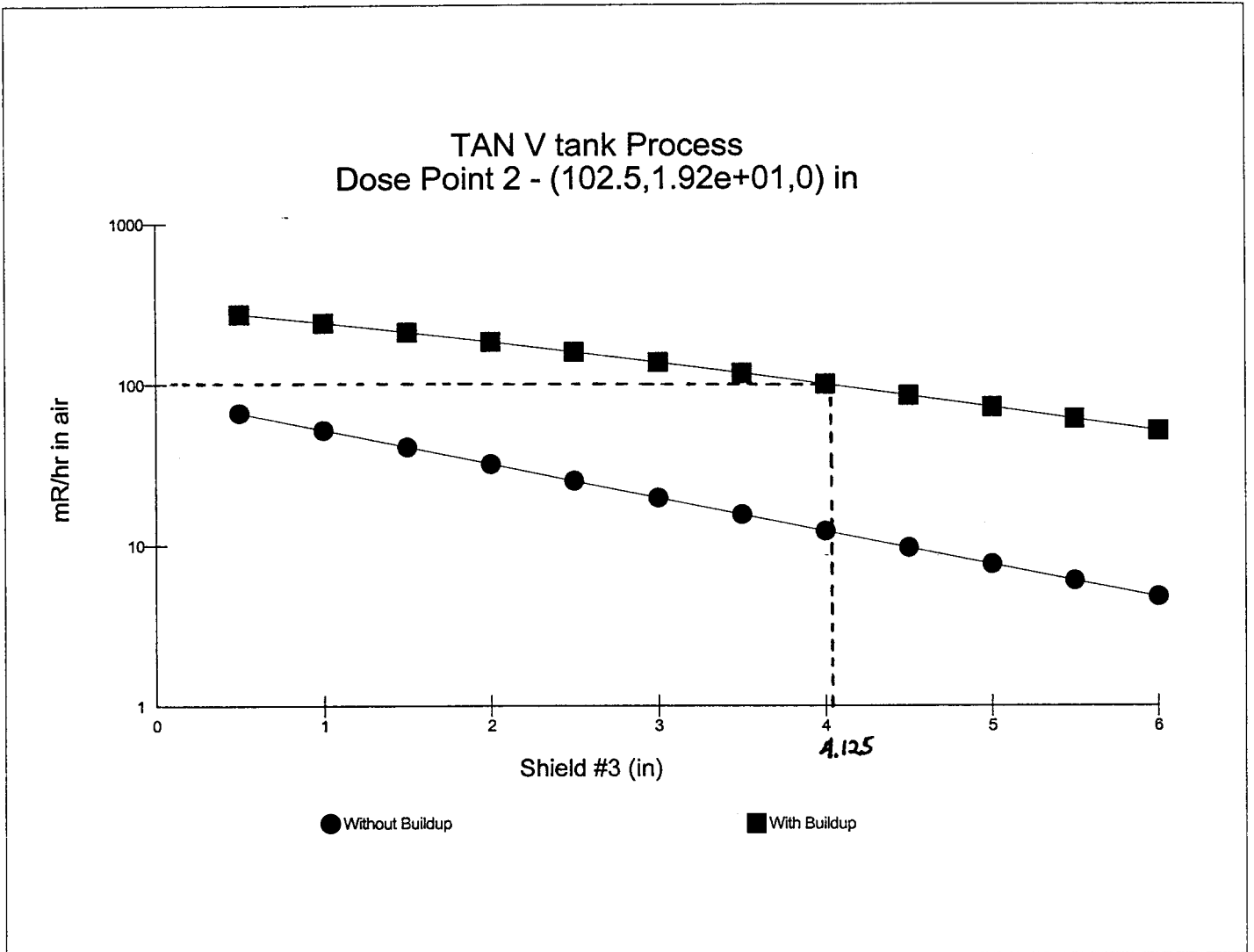

DOSE POINT @ 3 ft
Pb SHIELD (Lead)
100 mR/hr with $\approx \frac{5}{8}$ "

TAN V tank Process
Dose Point 2 - (102.5, 1.92e+01, 0) in

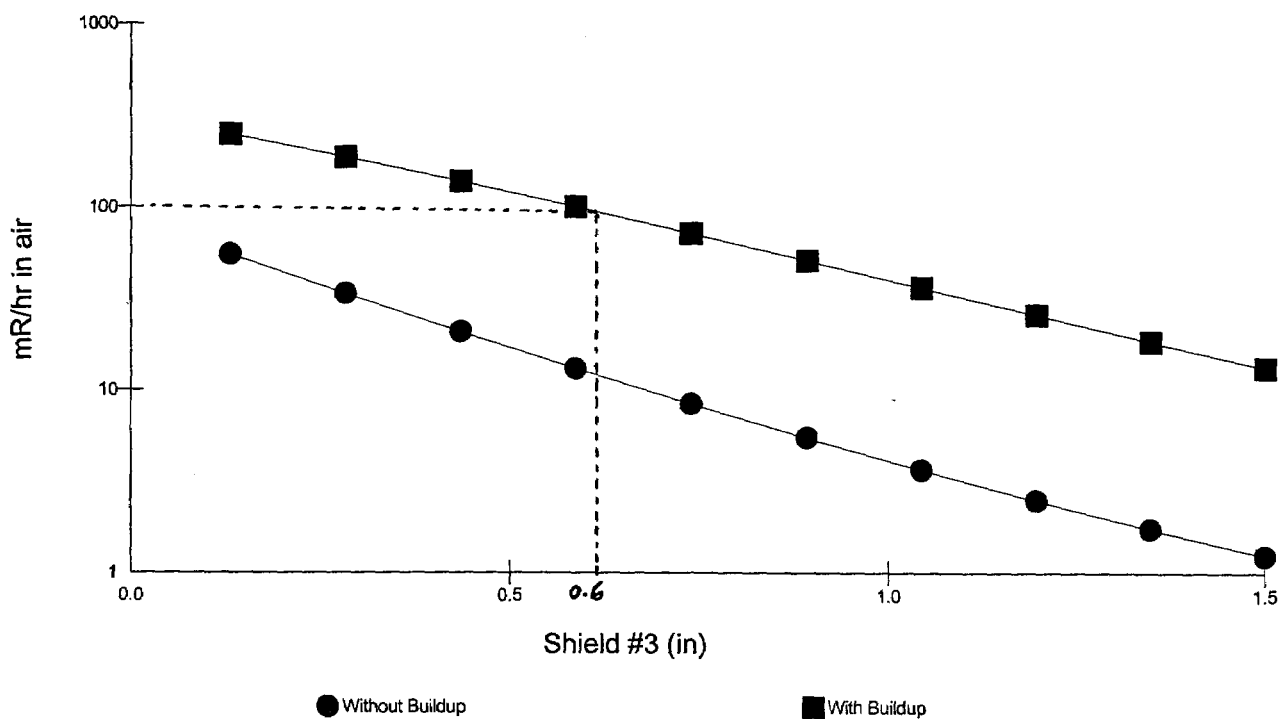

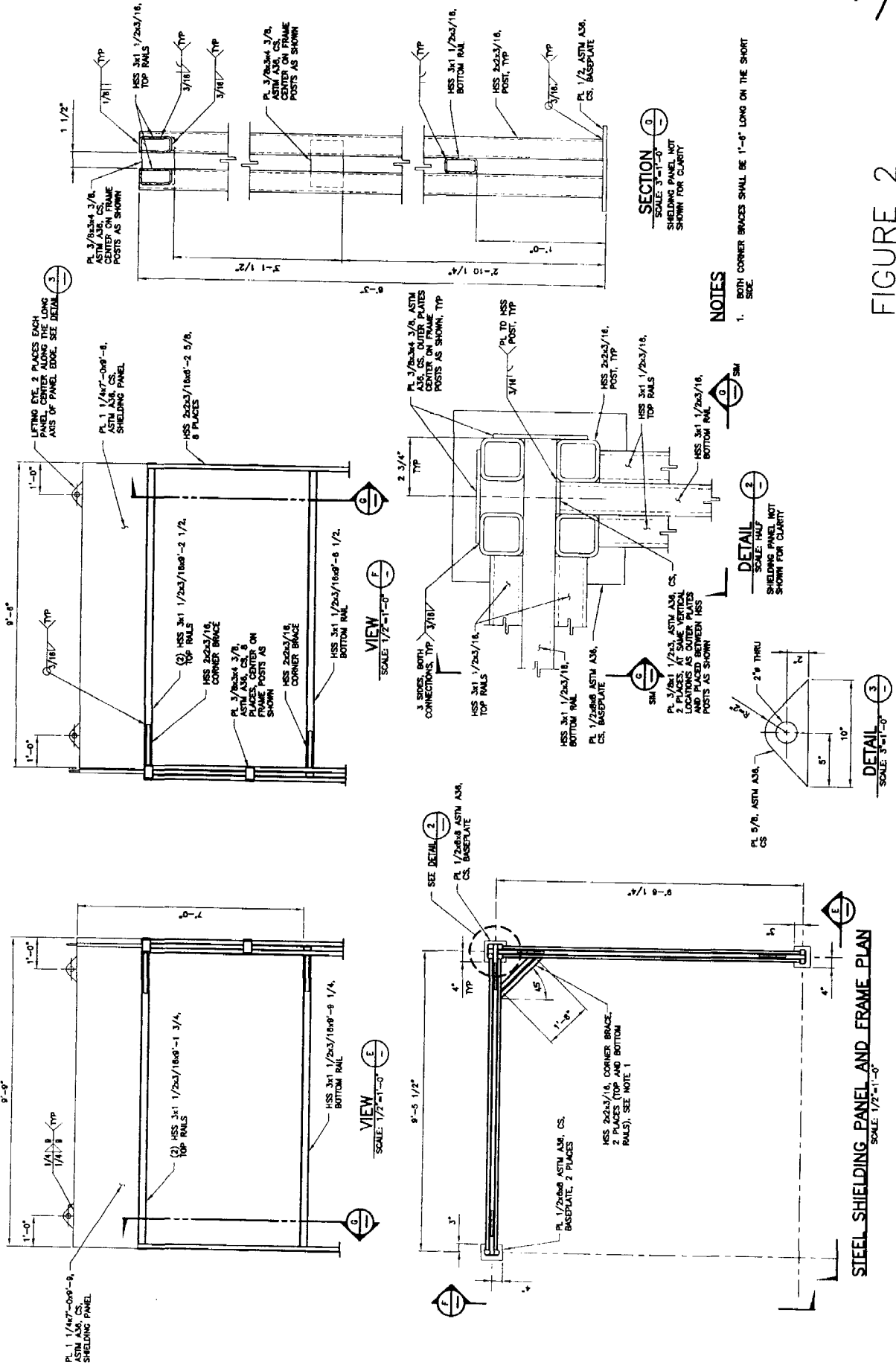

FIGURE 2

Results

See attached STAAD.pro input & output

For DL case:

$$\text{max. col. reaction (vert.)} = 1330 \#$$

$$\text{max. failure ratio} = 0.045 \ll 1.0 \text{ for Bm 6 (col. at corner)}$$

For DL + Lateral Case:

$$\text{max. col. reaction (vert.)} = 4160 \#$$

$$\text{max. failure ratio} = 0.71 < 1.0 \text{ for Bm 5 (col. at corner)}$$

$$\text{max. displ.} = 0.33'' \text{ in } z \text{ direction at Node 43}$$

Frame is adequate to support shield plates.

Frame Weight

$$\sum F_y \text{ reactions from DL case} = 7580 \#$$

$$P \text{ wt} = 7(10 + 9.75)(51.05) = 7060 \#$$

$$\text{Frame wt} \approx 7580 - 7060 = 520 \#$$

Max. Reaction

max. reaction at base P is $\sum F_y$ of nodes 3, 4, 5 & 6

$$R = 0.566 + 0.805 + 4.16 + 0 = 5.5 \# \text{ (DL + lateral)}$$

STAAD SPACE STEEL PLATE TANK SHIELD

START JOB INFORMATION

JOB NAME V-TANK CONTENTS REMOVAL -- CONSOLIDATION TANK SHIELDING

JOB NO EDF-4727

JOB COMMENT DL Case

ENGINEER NAME R Lippert

ENGINEER DATE 10-Mar-04

END JOB INFORMATION

INPUT WIDTH 79

UNIT INCHES POUND

JOINT COORDINATES

1 0 0 0; 2 0 0 3.5; 3 116.5 0 0; 4 116.5 0 3.5; 5 120 0 0; 6 120 0 3.5;
 7 116.5 0 120.5; 8 120 0 120.5; 9 0 13.5 0; 10 0 13.5 3.5; 11 116.5 13.5 0;
 12 116.5 13.5 3.5; 13 120 13.5 0; 14 120 13.5 3.5; 15 116.5 13.5 120.5;
 16 120 13.5 120.5; 17 0 73.5 0; 18 0 73.5 3.5; 19 116.5 73.5 0;
 20 116.5 73.5 3.5; 21 120 73.5 0; 22 120 73.5 3.5; 23 116.5 73.5 120.5;
 24 120 73.5 120.5; 25 0 13.5 1.75; 26 120 13.5 1.75; 27 118.25 13.5 3.5;
 28 118.25 13.5 120.5; 29 0 43.5 3.5; 30 0 43.5 0; 31 116.5 43.5 0;
 32 116.5 43.5 3.5; 33 120 43.5 0; 34 120 43.5 3.5; 35 116.5 43.5 120.5;
 36 120 43.5 120.5; 39 0 73.5 1.75; 40 120 73.5 1.75; 41 118.25 73.5 3.5;
 42 118.25 73.5 120.5; 43 0 97.5 1.75; 44 120 97.5 1.75; 45 118.5 97.5 3.5;
 46 118.5 97.5 120.5;

MEMBER INCIDENCES

1 1 9; 2 2 10; 3 3 11; 4 4 12; 5 5 13; 6 6 14; 7 7 15; 8 8 16; 9 9 30;
 10 10 29; 11 11 31; 12 12 32; 13 13 33; 14 14 34; 15 15 35; 16 16 36; 17 9 25;
 18 13 26; 19 14 27; 20 16 28; 21 25 10; 22 26 14; 23 27 12; 24 28 15; 25 25 26;
 26 27 28; 27 29 18; 28 30 17; 29 31 19; 30 32 20; 31 33 21; 32 34 22; 33 35 23;
 34 36 24; 35 30 29; 36 17 39; 37 21 19; 38 33 31; 39 21 40; 40 33 34; 41 36 35;
 42 24 42; 43 17 19; 44 18 20; 45 20 41; 46 32 34; 47 22 24; 48 20 23; 52 39 18;
 53 40 22; 55 41 22; 56 42 23;

ELEMENT INCIDENCES SHELL

57 27 41 42 28; 58 25 39 40 26; 59 39 43 44 40; 60 41 45 46 42;

ELEMENT PROPERTY

57 TO 60 THICKNESS 1.25

DEFINE MATERIAL START

ISOTROPIC STEEL

E 2.9e+007

POISSON 0.3

DENSITY 0.283

ALPHA 6.5e-006

DAMP 0.03

ISOTROPIC RIGID

E 1e+007

DENSITY 1e-007

END DEFINE MATERIAL

CONSTANTS

MATERIAL STEEL MEMB 1 TO 48 52 53 55 TO 60

MEMBER PROPERTY AMERICAN

1 TO 16 27 TO 42 45 46 52 53 55 56 TABLE ST TUB20203

17 TO 26 43 44 47 48 TABLE ST TUBE TH 0.188 WT 1.5 DT 3

SUPPORTS

1 TO 8 PINNED

LOAD 1 DEAD LOAD

SELFWEIGHT Y -1

UNIT INCHES KIP

PERFORM ANALYSIS PRINT ALL

PARAMETER

CODE AISC

TRACK 2 MEMB 1 TO 42 52 53 56

FYLD 46 MEMB 1 TO 42 52 53 56

CHECK CODE MEMB 1 3 TO 9 11 TO 16 25 26 28 TO 34 43 44 47 48

FINISH



Software licensed to INEEL

Job No EDF-5017	Sheet No 25 of 138	Rev
Part		
Ref		
By R Lippert	Date 10-Mar-04	Chd
Client	File TankShield1.std	Date/Time 29-Jun-2004 16:54

Job Title **V-TANK CONTENTS REMOVAL -- CONSOLIDATION TANK SHIELDING**

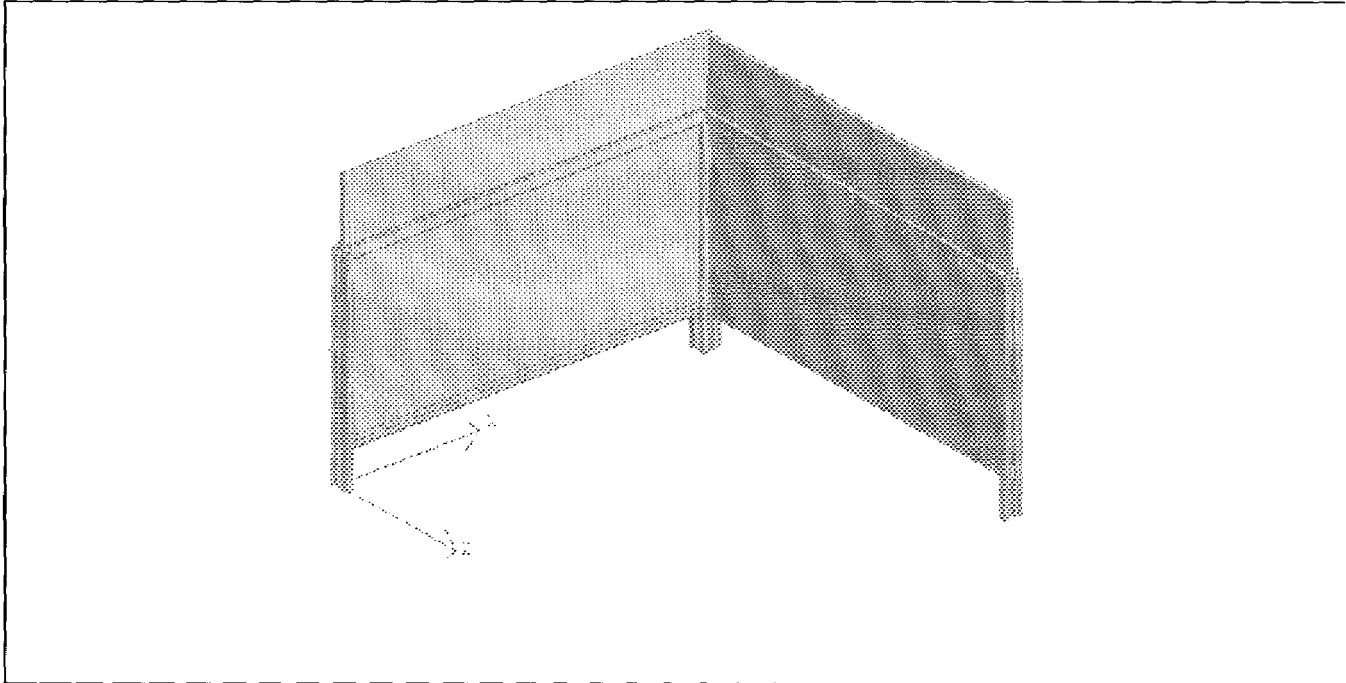

Support Frame with Shield Plates



Software licensed to INEEL

Job No EDF-5017	Sheet No 26 of 138	Rev
Part	Ref	
By R Lippert	Date 10-Mar-04	Chd
Client	File TankShield1.std	Date/Time 29-Jun-2004 16:54

Job Title **V-TANK CONTENTS REMOVAL -- CONSOLIDATION TANK SHIELDING**

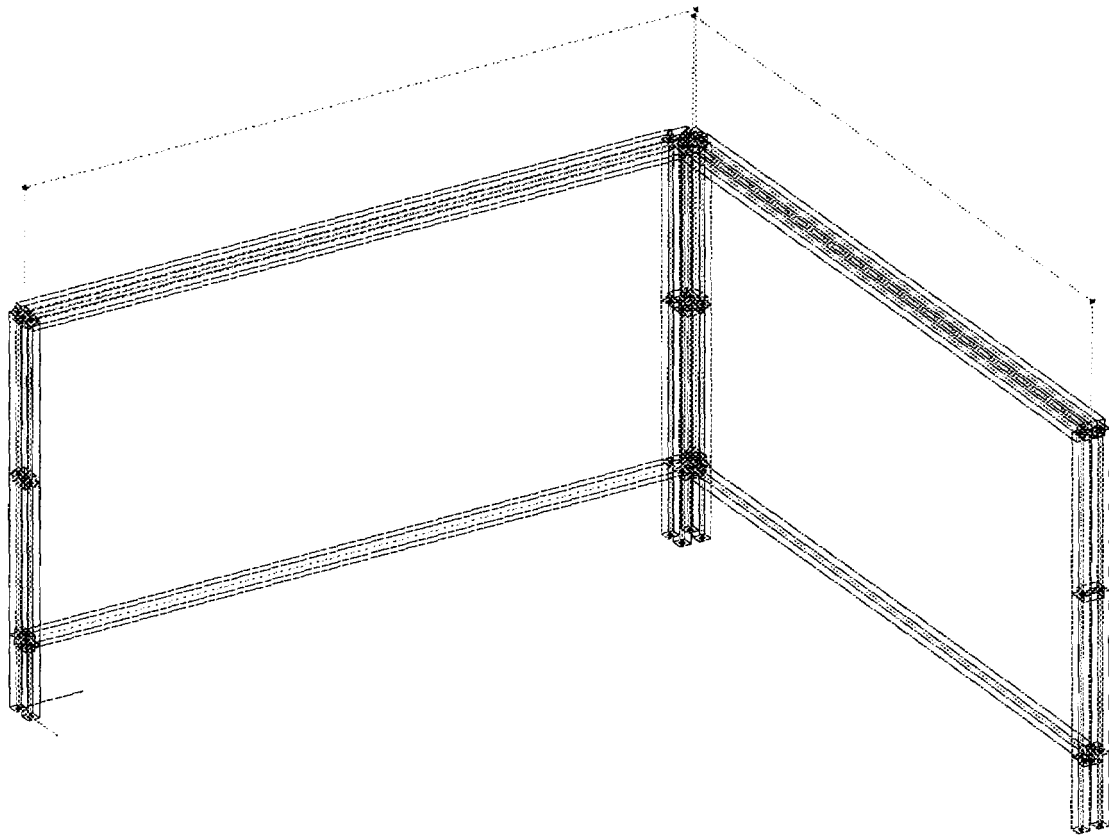

3D View: Shield Plate Support Frame



Software licensed to INEEL

Job No
EDF-5017

Sheet No
27 of 138

Rev

Job Title **V-TANK CONTENTS REMOVAL -- CONSOLIDATION TANK SHIELDING**

Part

Ref

By **R Lippert** Date **10-Mar-04** Chd

Client

File **TankShield1.std**

Date/Time **29-Jun-2004 16:54**

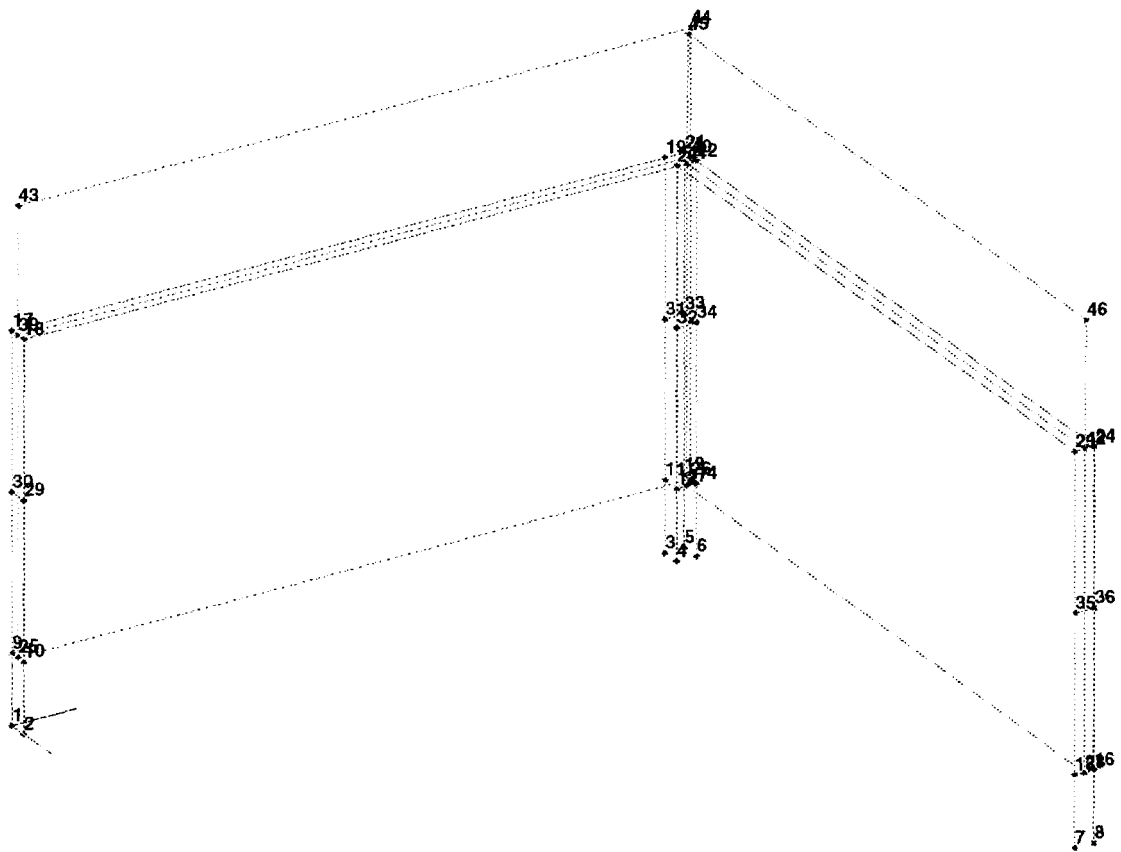

Node Numbers



Software licensed to INEEL

Job No
EDF-5017

Sheet No
28 of 138

Rev

Job Title **V-TANK CONTENTS REMOVAL -- CONSOLIDATION TANK SHIELDING**

Part

Ref

By **R Lippert** Date **10-Mar-04** Chd

Client

File **TankShield1.std**

Date/Time **29-Jun-2004 16:54**

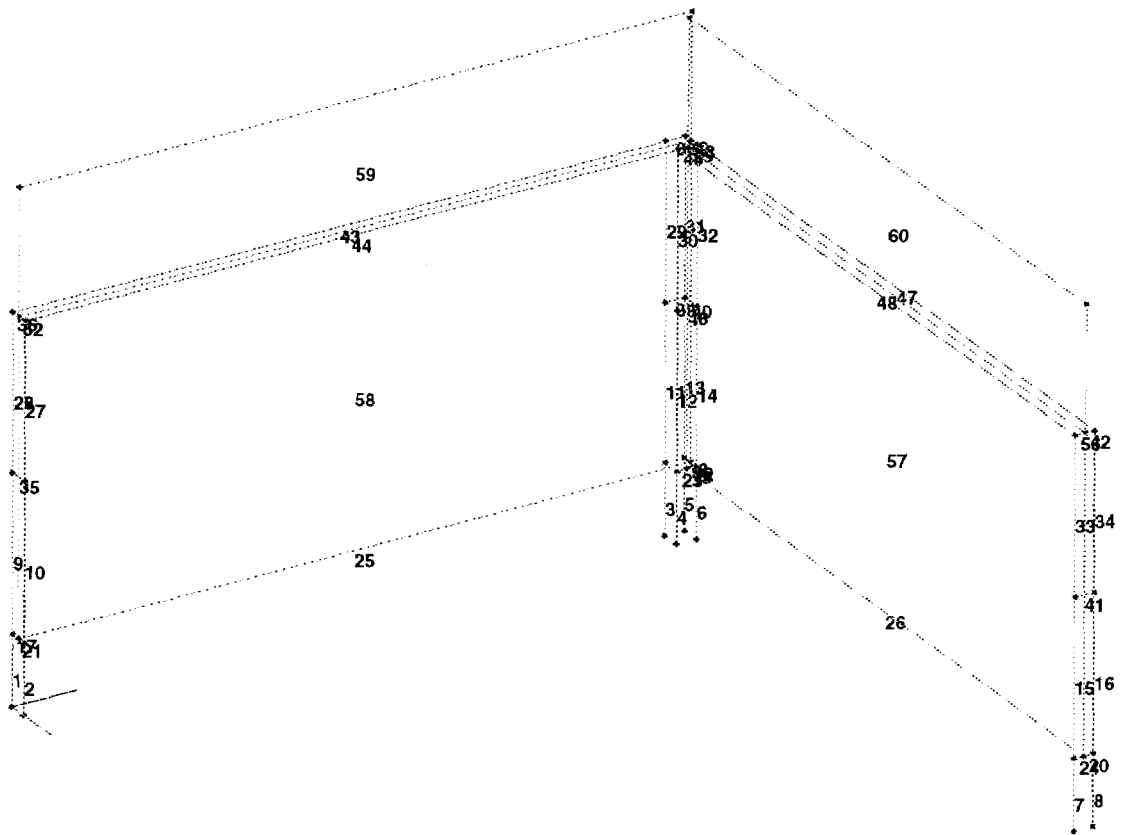

Beam & Plate Numbers



Software licensed to INEEL

Job No EDF-5017	Sheet No 29 of 138	Rev
Part		
Ref		
By R Lippert	Date 10-Mar-04	Chd
Client	File TankShield1.std	Date/Time 29-Jun-2004 16:54

Job Title **V-TANK CONTENTS REMOVAL -- CONSOLIDATION TANK SHIELDING**

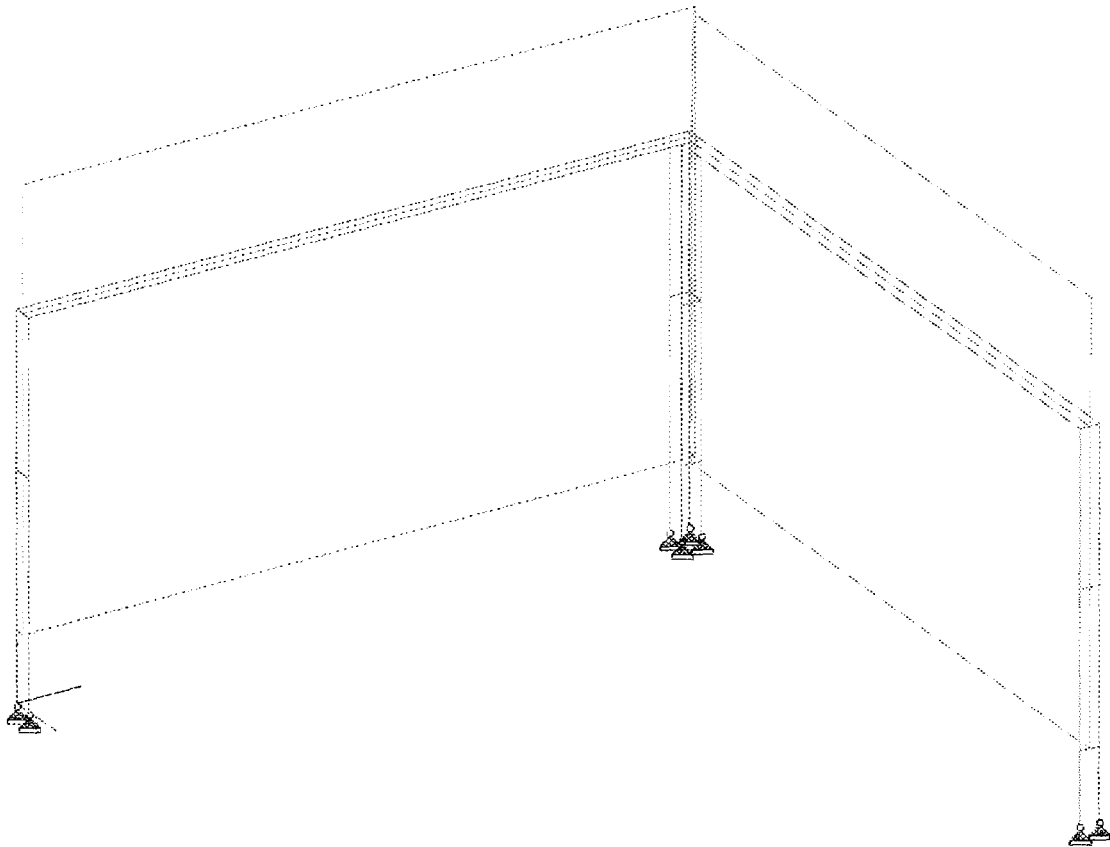

DL Supports



Software licensed to INEEL

Job No EDF-5017	Sheet No 30 of 138	Rev
Part		
Ref		
By R Lippert	Date 10-Mar-04	Chd
Client	File TankShield1.std	Date/Time 29-Jun-2004 16:54

Job Title **V-TANK CONTENTS REMOVAL -- CONSOLIDATION TANK SHIELDING**

Job Information

	Engineer	Checked	Approved
Name:	R Lippert		
Date:	10-Mar-04		

Comments

DL Case

Structure Type | SPACE FRAME

Number of Nodes	44	Highest Node	46
Number of Elements	52	Highest Beam	56
Number of Plates	4	Highest Plate	60

Number of Basic Load Cases	1
Number of Combination Load Cases	0

Included in this printout are data for:

All	The Whole Structure
------------	---------------------

Included in this printout are results for load cases:

Type	L/C	Name
Primary	1	DEAD LOAD

Nodes

Node	X (in)	Y (in)	Z (in)
1	0.000	0.000	0.000
2	0.000	0.000	3.500
3	116.500	0.000	0.000
4	116.500	0.000	3.500
5	120.000	0.000	0.000
6	120.000	0.000	3.500
7	116.500	0.000	120.500
8	120.000	0.000	120.500
9	0.000	13.500	0.000
10	0.000	13.500	3.500
11	116.500	13.500	0.000
12	116.500	13.500	3.500
13	120.000	13.500	0.000
14	120.000	13.500	3.500
15	116.500	13.500	120.500
16	120.000	13.500	120.500
17	0.000	73.500	0.000
18	0.000	73.500	3.500



Software licensed to INEEL

Job No EDF-5017	Sheet No 31 of 138	Rev
Part		
Ref		
By R Lippert	Date 10-Mar-04	Chd
Client	File TankShield1.std	Date/Time 29-Jun-2004 16:54

Job Title **V-TANK CONTENTS REMOVAL -- CONSOLIDATION TANK SHIELDING**

Nodes Cont...

Node	X (in)	Y (in)	Z (in)
19	116.500	73.500	0.000
20	116.500	73.500	3.500
21	120.000	73.500	0.000
22	120.000	73.500	3.500
23	116.500	73.500	120.500
24	120.000	73.500	120.500
25	0.000	13.500	1.750
26	120.000	13.500	1.750
27	118.250	13.500	3.500
28	118.250	13.500	120.500
29	0.000	43.500	3.500
30	0.000	43.500	0.000
31	116.500	43.500	0.000
32	116.500	43.500	3.500
33	120.000	43.500	0.000
34	120.000	43.500	3.500
35	116.500	43.500	120.500
36	120.000	43.500	120.500
39	0.000	73.500	1.750
40	120.000	73.500	1.750
41	118.250	73.500	3.500
42	118.250	73.500	120.500
43	0.000	97.500	1.750
44	120.000	97.500	1.750
45	118.500	97.500	3.500
46	118.500	97.500	120.500

Beams

Beam	Node A	Node B	Length (in)	Property	β (degrees)
1	1	9	13.500	2	0
2	2	10	13.500	2	0
3	3	11	13.500	2	0
4	4	12	13.500	2	0
5	5	13	13.500	2	0
6	6	14	13.500	2	0
7	7	15	13.500	2	0
8	8	16	13.500	2	0
9	9	30	30.000	2	0
10	10	29	30.000	2	0
11	11	31	30.000	2	0
12	12	32	30.000	2	0
13	13	33	30.000	2	0
14	14	34	30.000	2	0



Software licensed to INEEL

Job No
EDF-5017

Sheet No
32 of 138

Rev

Part

Job Title **V-TANK CONTENTS REMOVAL -- CONSOLIDATION TANK SHIELDING**

Ref

By **R Lippert** Date **10-Mar-04** Chd

Client

File **TankShield1.std**

Date/Time **29-Jun-2004 16:54**

Beams Cont...

Beam	Node A	Node B	Length (in)	Property	β (degrees)
15	15	35	30.000	2	0
16	16	36	30.000	2	0
17	9	25	1.750	3	0
18	13	26	1.750	3	0
19	14	27	1.750	3	0
20	16	28	1.750	3	0
21	25	10	1.750	3	0
22	26	14	1.750	3	0
23	27	12	1.750	3	0
24	28	15	1.750	3	0
25	25	26	120.000	3	0
26	27	28	117.000	3	0
27	29	18	30.000	2	0
28	30	17	30.000	2	0
29	31	19	30.000	2	0
30	32	20	30.000	2	0
31	33	21	30.000	2	0
32	34	22	30.000	2	0
33	35	23	30.000	2	0
34	36	24	30.000	2	0
35	30	29	3.500	2	0
36	17	39	1.750	2	0
37	21	19	3.500	2	0
38	33	31	3.500	2	0
39	21	40	1.750	2	0
40	33	34	3.500	2	0
41	36	35	3.500	2	0
42	24	42	1.750	2	0
43	17	19	116.500	3	0
44	18	20	116.500	3	0
45	20	41	1.750	2	0
46	32	34	3.500	2	0
47	22	24	117.000	3	0
48	20	23	117.000	3	0
52	39	18	1.750	2	0
53	40	22	1.750	2	0
55	41	22	1.750	2	0
56	42	23	1.750	2	0



Software licensed to INEEL

Job No
EDF-5017

Sheet No
33 of 138

Rev

Job Title **V-TANK CONTENTS REMOVAL -- CONSOLIDATION TANK SHIELDING**

Part

Ref

By **R Lippert** Date **10-Mar-04** Chd

Client

File **TankShield1.std**

Date/Time **29-Jun-2004 16:54**

Plates

Plate	Node A	Node B	Node C	Node D	Property
57	27	41	42	28	1
58	25	39	40	26	1
59	39	43	44	40	1
60	41	45	46	42	1

Section Properties

Prop	Section	Area (in ²)	I _{yy} (in ⁴)	I _{zz} (in ⁴)	J (in ⁴)	Material
2	TUB20203	1.270	0.700	0.700	1.116	STEEL
3	TUBE 3x1 1/2 x 3/16	1.551	0.533	1.683	1.241	STEEL

Plate Thickness

Prop	Node A (in)	Node B (in)	Node C (in)	Node D (in)	Material
1	1.250	1.250	1.250	1.250	STEEL

Materials

Mat	Name	E (kip/in ²)	v	Density (kip/in ³)	α (1/K)
1	RIGID	10E 3	0.000	0.000	0.000
2	STEEL	29E 3	0.300	0.000	3.61E -6
3	ALUMINUM	10E 3	0.330	0.000	7.11E -6
4	CONCRETE	3.15E 3	0.170	0.000	3.06E -6

Supports

Node	X (kip/in)	Y (kip/in)	Z (kip/in)	rX (kip ft/deg)	rY (kip ft/deg)	rZ (kip ft/deg)
1	Fixed	Fixed	Fixed	-	-	-
2	Fixed	Fixed	Fixed	-	-	-
3	Fixed	Fixed	Fixed	-	-	-
4	Fixed	Fixed	Fixed	-	-	-
5	Fixed	Fixed	Fixed	-	-	-
6	Fixed	Fixed	Fixed	-	-	-
7	Fixed	Fixed	Fixed	-	-	-
8	Fixed	Fixed	Fixed	-	-	-



Software licensed to INEEL

Job No EDF-5017	Sheet No 34 of 138	Rev
Part		
Ref		
By R Lippert	Date 10-Mar-04	Chg
Client	File TankShield1.std	Date/Time 29-Jun-2004 16:54

Job Title **V-TANK CONTENTS REMOVAL -- CONSOLIDATION TANK SHIELDING**

Basic Load Cases

Number	Name
1	DEAD LOAD

Selfweight : 1 DEAD LOAD

Direction	Factor
Y	-1.000

Node Displacement Summary

	Node	L/C	X (in)	Y (in)	Z (in)	Resultant (in)	rX (rad)	rY (rad)	rZ (rad)
Max X	46	1:DEAD LOAD	0.001	-0.001	0.000	0.001	0.000	0.000	-0.000
Min X	30	1:DEAD LOAD	-0.000	-0.001	0.000	0.001	-0.000	0.000	0.000
Max Y	1	1:DEAD LOAD	0.000	0.000	0.000	0.000	-0.000	0.000	0.000
Min Y	41	1:DEAD LOAD	0.000	-0.001	0.000	0.001	-0.000	-0.000	0.000
Max Z	44	1:DEAD LOAD	0.000	-0.001	0.001	0.002	0.000	0.000	-0.000
Min Z	32	1:DEAD LOAD	0.000	-0.001	-0.000	0.001	0.000	-0.000	0.000
Max rX	21	1:DEAD LOAD	0.000	-0.001	0.000	0.001	0.000	0.000	-0.000
Min rX	23	1:DEAD LOAD	0.000	-0.001	0.000	0.001	-0.000	0.000	-0.000
Max rY	46	1:DEAD LOAD	0.001	-0.001	0.000	0.001	0.000	0.000	-0.000
Min rY	26	1:DEAD LOAD	0.000	-0.001	0.000	0.001	0.000	-0.000	-0.000
Max rZ	20	1:DEAD LOAD	0.000	-0.001	0.000	0.001	0.000	-0.000	0.000
Min rZ	18	1:DEAD LOAD	0.000	-0.001	0.000	0.001	-0.000	-0.000	-0.000
Max Rst	44	1:DEAD LOAD	0.000	-0.001	0.001	0.002	0.000	0.000	-0.000

Reactions

Node	L/C	Horizontal	Vertical	Horizontal	Moment		
		FX (kip)	FY (kip)	FZ (kip)	MX (kip'in)	MY (kip'in)	MZ (kip'in)
1	1:DEAD LOAD	0.006	0.938	0.005	0.000	0.000	0.000
2	1:DEAD LOAD	0.005	0.966	-0.005	0.000	0.000	0.000
3	1:DEAD LOAD	0.001	0.368	0.000	0.000	0.000	0.000
4	1:DEAD LOAD	0.003	1.080	0.003	0.000	0.000	0.000
5	1:DEAD LOAD	-0.007	1.013	0.011	0.000	0.000	0.000
6	1:DEAD LOAD	-0.007	1.332	0.002	0.000	0.000	0.000
7	1:DEAD LOAD	0.005	0.929	-0.009	0.000	0.000	0.000
8	1:DEAD LOAD	-0.005	0.954	-0.008	0.000	0.000	0.000



Software licensed to INEEL

Job No
EDF-5017

Sheet No
35 of 138

Rev

Part

Job Title **V-TANK CONTENTS REMOVAL -- CONSOLIDATION TANK SHIELDING**

Ref

By **R Lippert** Date **10-Mar-04** Chd

Client

File **TankShield1.std**

Date/Time **29-Jun-2004 16:54**

Failure Ratio

Beam	Analysis Property	New Property	Ratio	Ay (in ²)	Az (in ²)	Ax (in ²)	Dw (in)	Bf (in)	Iz (in ⁴)	Iy (in ⁴)	Ix (in ⁴)
1	TUB20203	TUB20203	0.035	0.750	0.750	1.270	2.000	2.000	0.700	0.700	1.200
2	TUB20203	TUB20203	0.000	0.750	0.750	1.270	2.000	2.000	0.700	0.700	1.200
3	TUB20203	TUB20203	0.012	0.750	0.750	1.270	2.000	2.000	0.700	0.700	1.200
4	TUB20203	TUB20203	0.036	0.750	0.750	1.270	2.000	2.000	0.700	0.700	1.200
5	TUB20203	TUB20203	0.042	0.750	0.750	1.270	2.000	2.000	0.700	0.700	1.200
6	TUB20203	TUB20203	0.045	0.750	0.750	1.270	2.000	2.000	0.700	0.700	1.200
7	TUB20203	TUB20203	0.036	0.750	0.750	1.270	2.000	2.000	0.700	0.700	1.200
8	TUB20203	TUB20203	0.037	0.750	0.750	1.270	2.000	2.000	0.700	0.700	1.200
9	TUB20203	TUB20203	0.015	0.750	0.750	1.270	2.000	2.000	0.700	0.700	1.200
10	TUB20203	TUB20203	0.000	0.750	0.750	1.270	2.000	2.000	0.700	0.700	1.200
11	TUB20203	TUB20203	0.014	0.750	0.750	1.270	2.000	2.000	0.700	0.700	1.200
12	TUB20203	TUB20203	0.019	0.750	0.750	1.270	2.000	2.000	0.700	0.700	1.200
13	TUB20203	TUB20203	0.019	0.750	0.750	1.270	2.000	2.000	0.700	0.700	1.200
14	TUB20203	TUB20203	0.014	0.750	0.750	1.270	2.000	2.000	0.700	0.700	1.200
15	TUB20203	TUB20203	0.013	0.750	0.750	1.270	2.000	2.000	0.700	0.700	1.200
16	TUB20203	TUB20203	0.014	0.750	0.750	1.270	2.000	2.000	0.700	0.700	1.200
17	TUBE	TUB E	0.000	1.128	0.564	1.551	3.000	1.500	1.683	0.533	1.241
18	TUBE	TUB E	0.000	1.128	0.564	1.551	3.000	1.500	1.683	0.533	1.241
19	TUBE	TUB E	0.000	1.128	0.564	1.551	3.000	1.500	1.683	0.533	1.241
20	TUBE	TUB E	0.000	1.128	0.564	1.551	3.000	1.500	1.683	0.533	1.241
21	TUBE	TUB E	0.000	1.128	0.564	1.551	3.000	1.500	1.683	0.533	1.241
22	TUBE	TUB E	0.000	1.128	0.564	1.551	3.000	1.500	1.683	0.533	1.241
23	TUBE	TUB E	0.000	1.128	0.564	1.551	3.000	1.500	1.683	0.533	1.241
24	TUBE	TUB E	0.000	1.128	0.564	1.551	3.000	1.500	1.683	0.533	1.241
25	TUBE	TUB E	0.022	1.128	0.564	1.551	3.000	1.500	1.683	0.533	1.241
26	TUBE	TUB E	0.020	1.128	0.564	1.551	3.000	1.500	1.683	0.533	1.241
27	TUB20203	TUB20203	0.000	0.750	0.750	1.270	2.000	2.000	0.700	0.700	1.200
28	TUB20203	TUB20203	0.015	0.750	0.750	1.270	2.000	2.000	0.700	0.700	1.200
29	TUB20203	TUB20203	0.013	0.750	0.750	1.270	2.000	2.000	0.700	0.700	1.200
30	TUB20203	TUB20203	0.017	0.750	0.750	1.270	2.000	2.000	0.700	0.700	1.200
31	TUB20203	TUB20203	0.021	0.750	0.750	1.270	2.000	2.000	0.700	0.700	1.200
32	TUB20203	TUB20203	0.016	0.750	0.750	1.270	2.000	2.000	0.700	0.700	1.200
33	TUB20203	TUB20203	0.014	0.750	0.750	1.270	2.000	2.000	0.700	0.700	1.200
34	TUB20203	TUB20203	0.014	0.750	0.750	1.270	2.000	2.000	0.700	0.700	1.200
35	TUB20203	TUB20203	0.000	0.750	0.750	1.270	2.000	2.000	0.700	0.700	1.200
36	TUB20203	TUB20203	0.000	0.750	0.750	1.270	2.000	2.000	0.700	0.700	1.200
37	TUB20203	TUB20203	0.000	0.750	0.750	1.270	2.000	2.000	0.700	0.700	1.200
38	TUB20203	TUB20203	0.000	0.750	0.750	1.270	2.000	2.000	0.700	0.700	1.200
39	TUB20203	TUB20203	0.000	0.750	0.750	1.270	2.000	2.000	0.700	0.700	1.200
40	TUB20203	TUB20203	0.000	0.750	0.750	1.270	2.000	2.000	0.700	0.700	1.200
41	TUB20203	TUB20203	0.000	0.750	0.750	1.270	2.000	2.000	0.700	0.700	1.200
42	TUB20203	TUB20203	0.000	0.750	0.750	1.270	2.000	2.000	0.700	0.700	1.200
43	TUBE	TUB E	0.024	1.128	0.564	1.551	3.000	1.500	1.683	0.533	1.241
44	TUBE	TUB E	0.021	1.128	0.564	1.551	3.000	1.500	1.683	0.533	1.241
45	TUB20203	TUB20203	0.000	0.750	0.750	1.270	2.000	2.000	0.700	0.700	1.200
46	TUB20203	TUB20203	0.000	0.750	0.750	1.270	2.000	2.000	0.700	0.700	1.200



Software licensed to INEEL

Job No
EDF-5017

Sheet No
36 of 138

Rev

Part

Job Title **V-TANK CONTENTS REMOVAL -- CONSOLIDATION TANK SHIELDING**

Ref

By **R Lippert** Date **10-Mar-04** Chd

Client

File **TankShield1.std**

Date/Time **29-Jun-2004 16:54**

Failure Ratio Cont...

Beam	Analysis Property	New Property	Ratio	Ay (in ²)	Az (in ²)	Ax (in ²)	Dw (in)	Bf (in)	Iz (in ⁴)	Iy (in ⁴)	Ix (in ⁴)
47	TUBE	TUB E	0.021	1.128	0.564	1.551	3.000	1.500	1.683	0.533	1.241
48	TUBE	TUB E	0.020	1.128	0.564	1.551	3.000	1.500	1.683	0.533	1.241
52	TUB20203	TUB20203	0.000	0.750	0.750	1.270	2.000	2.000	0.700	0.700	1.200
53	TUB20203	TUB20203	0.000	0.750	0.750	1.270	2.000	2.000	0.700	0.700	1.200
55	TUB20203	TUB20203	0.000	0.750	0.750	1.270	2.000	2.000	0.700	0.700	1.200
56	TUB20203	TUB20203	0.000	0.750	0.750	1.270	2.000	2.000	0.700	0.700	1.200

```

STAAD SPACE STEEL PLATE TANK SHIELD
START JOB INFORMATION
JOB NAME V-TANK CONTENTS REMOVAL -- CONSOLIDATION TANK SHIELDING
JOB NO EDF-4727
JOB COMMENT DL+LATERAL Case
ENGINEER NAME R Lippert
ENGINEER DATE 10-Mar-04
END JOB INFORMATION
INPUT WIDTH 79
UNIT INCHES POUND
JOINT COORDINATES
1 0 0 0; 2 0 0 3.5; 3 116.5 0 0; 4 116.5 0 3.5; 5 120 0 0; 6 120 0 3.5;
7 116.5 0 120.5; 8 120 0 120.5; 9 0 13.5 0; 10 0 13.5 3.5; 11 116.5 13.5 0;
12 116.5 13.5 3.5; 13 120 13.5 0; 14 120 13.5 3.5; 15 116.5 13.5 120.5;
16 120 13.5 120.5; 17 0 73.5 0; 18 0 73.5 3.5; 19 116.5 73.5 0;
20 116.5 73.5 3.5; 21 120 73.5 0; 22 120 73.5 3.5; 23 116.5 73.5 120.5;
24 120 73.5 120.5; 25 0 13.5 1.75; 26 120 13.5 1.75; 27 118.25 13.5 3.5;
28 118.25 13.5 120.5; 29 0 43.5 3.5; 30 0 43.5 0; 31 116.5 43.5 0;
32 116.5 43.5 3.5; 33 120 43.5 0; 34 120 43.5 3.5; 35 116.5 43.5 120.5;
36 120 43.5 120.5; 39 0 73.5 1.75; 40 120 73.5 1.75; 41 118.25 73.5 3.5;
42 118.25 73.5 120.5; 43 0 97.5 1.75; 44 120 97.5 1.75; 45 118.5 97.5 3.5;
46 118.5 97.5 120.5;
MEMBER INCIDENCES
1 1 9; 2 2 10; 3 3 11; 4 4 12; 5 5 13; 6 6 14; 7 7 15; 8 8 16; 9 9 30;
10 10 29; 11 11 31; 12 12 32; 13 13 33; 14 14 34; 15 15 35; 16 16 36; 17 9 25;
18 13 26; 19 14 27; 20 16 28; 21 25 10; 22 26 14; 23 27 12; 24 28 15; 25 25 26;
26 27 28; 27 29 18; 28 30 17; 29 31 19; 30 32 20; 31 33 21; 32 34 22; 33 35 23;
34 36 24; 35 30 29; 36 17 39; 37 21 19; 38 33 31; 39 21 40; 40 33 34; 41 36 35;
42 24 42; 43 17 19; 44 18 20; 45 20 41; 46 32 34; 47 22 24; 48 20 23; 52 39 18;
53 40 22; 55 41 22; 56 42 23;
ELEMENT INCIDENCES SHELL
57 27 41 42 28; 58 25 39 40 26; 59 39 43 44 40; 60 41 45 46 42;
ELEMENT PROPERTY
57 TO 60 THICKNESS 1.25
DEFINE MATERIAL START
ISOTROPIC STEEL
E 2.9e+007
POISSON 0.3
DENSITY 0.283
ALPHA 6.5e-006
DAMP 0.03
ISOTROPIC RIGID
E 1e+007
DENSITY 1e-007
END DEFINE MATERIAL
CONSTANTS
MATERIAL STEEL MEMB 1 TO 48 52 53 55 TO 60
MEMBER PROPERTY AMERICAN
1 TO 16 27 TO 42 45 46 52 53 55 56 TABLE ST TUB20203
17 TO 26 43 44 47 48 TABLE ST TUBE TH 0.188 WT 1.5 DT 3
SUPPORTS
1 3 TO 5 7 PINNED
2 6 8 FIXED BUT FY MX MY MZ
LOAD 1 DEAD LOAD
SELFWEIGHT Y -1
UNIT FEET POUND
LOAD 2 LATERAL -Z
UNIT INCHES POUND
ELEMENT LOAD
58 59 PR GZ -0.071
JOINT LOAD
41 FZ -2240
27 FZ -1244
LOAD COMB 3 DL+LZ
1 1.0 2 1.0
UNIT INCHES KIP
PERFORM ANALYSIS PRINT ALL
PARAMETER
CODE AISC
TRACK 2 MEMB 1 TO 42 52 53 56
FYLD 46 MEMB 1 TO 42 52 53 56
CHECK CODE MEMB 1 3 TO 9 11 TO 16 25 26 28 TO 34 43 44 47 48
FINISH

```



Software licensed to INEEL

Job No
EDF-5017

Sheet No
38 of 138

Rev

Part

Job Title **V-TANK CONTENTS REMOVAL -- CONSOLIDATION TANK SHIELDING**

Ref

By **R Lippert** Date **10-Mar-04** Chd

Client

File **TankShield2.std**

Date/Time **30-Jun-2004 15:45**

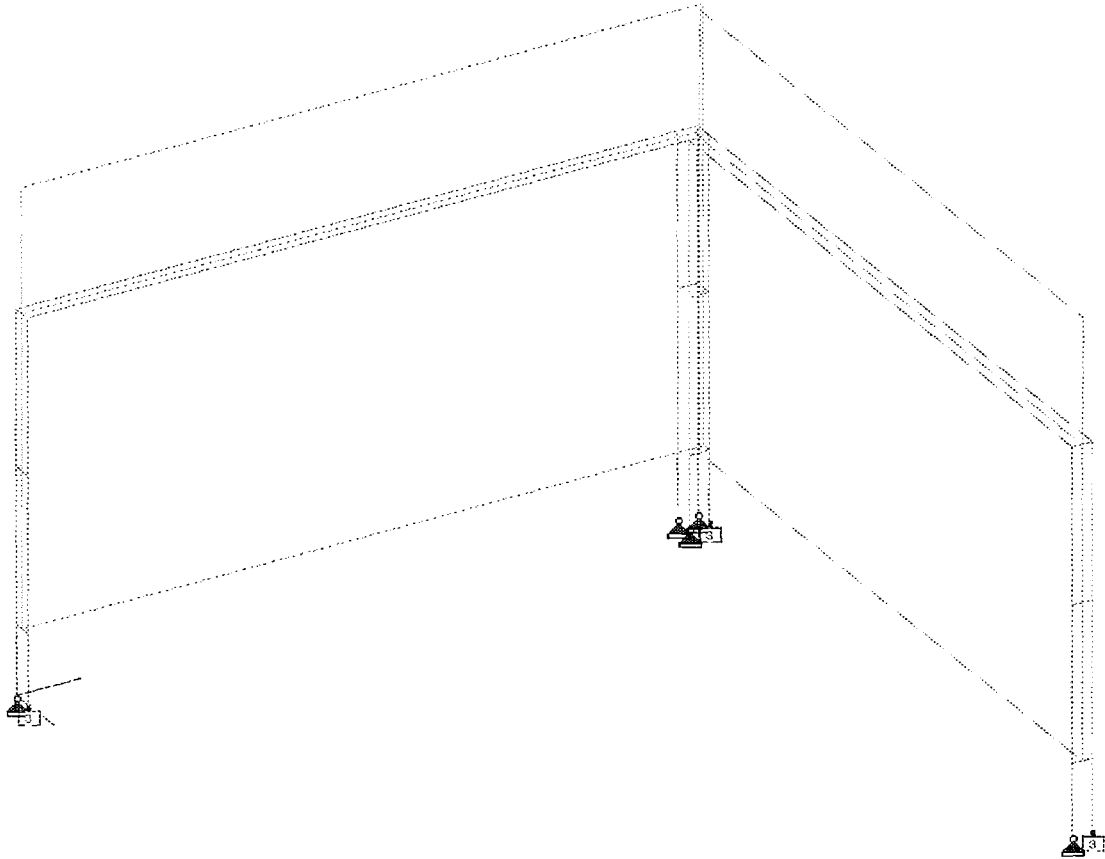

Supports for DL+Lateral Case



Software licensed to INEEL

Job No
EDF-5017

Sheet No
39 of 138

Rev

Job Title **V-TANK CONTENTS REMOVAL -- CONSOLIDATION TANK SHIELDING**

Part

Ref

By **R Lippert** Date **10-Mar-04** Chd

Client

File **TankShield2.std**

Date/Time **30-Jun-2004 15:45**

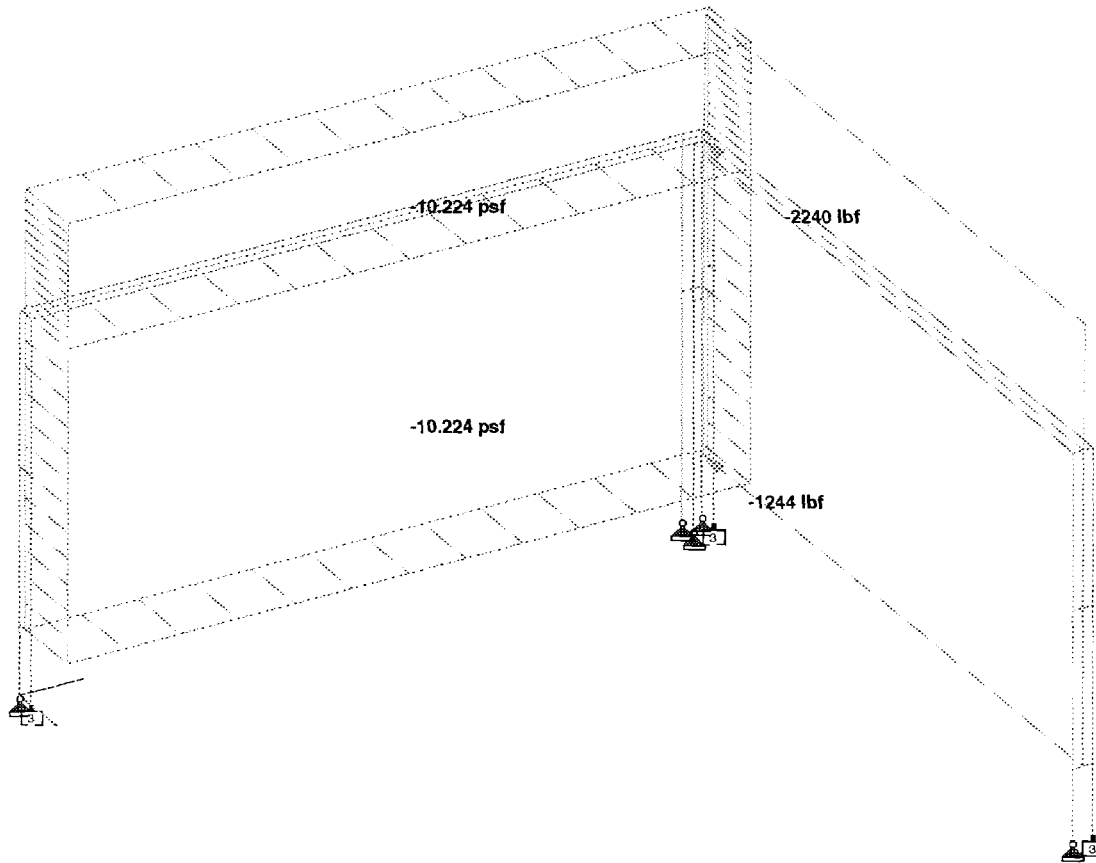

Lateral Load (0.2 g's)



Software licensed to INEEL

Job No
EDF-5017

Sheet No
40 of 138

Rev

Part

Job Title **V-TANK CONTENTS REMOVAL -- CONSOLIDATION TANK SHIELDING**

Ref

By **R Lippert** Date **10-Mar-04** Chd

Client

File **TankShield2.std**

Date/Time **30-Jun-2004 15:45**

Job Information

	Engineer	Checked	Approved
Name:	R Lippert		
Date:	10-Mar-04		

Comments

DL + Lateral Case

Structure Type | SPACE FRAME

Number of Nodes	44	Highest Node	46
Number of Elements	52	Highest Beam	56
Number of Plates	4	Highest Plate	60

Number of Basic Load Cases	2
Number of Combination Load Cases	1

Included in this printout are data for:

All | The Whole Structure

Included in this printout are results for load cases:

Type	L/C	Name
Combination	3	DL+LZ

Supports

Node	X (kip/in)	Y (kip/in)	Z (kip/in)	rX (kip ft/deg)	rY (kip ft/deg)	rZ (kip ft/deg)
1	Fixed	Fixed	Fixed	-	-	-
2	Fixed	-	Fixed	-	-	-
3	Fixed	Fixed	Fixed	-	-	-
4	Fixed	Fixed	Fixed	-	-	-
5	Fixed	Fixed	Fixed	-	-	-
6	Fixed	-	Fixed	-	-	-
7	Fixed	Fixed	Fixed	-	-	-
8	Fixed	-	Fixed	-	-	-

Basic Load Cases

Number	Name
1	DEAD LOAD
2	LATERAL -Z



Software licensed to :NEEL

Job No
EDF-5017

Sheet No
41 of 138

Rev

Part

Job Title **V-TANK CONTENTS REMOVAL -- CONSOLIDATION TANK SHIELDING**

Ref

By **R Lippert** Date **10-Mar-04** Chd

Client

File **TankShield2.std**

Date/Time **30-Jun-2004 15:45**

Comb.	Combination L/C Name	Primary	Primary L/C Name	Factor
3	DL+LZ	1	DEAD LOAD	1.00
		2	LATERAL -Z	1.00

Selfweight : 1 DEAD LOAD

Direction	Factor
Y	-1.000

Node Loads : 2 LATERAL -Z

Node	FX (lb)	FY (lb)	FZ (lb)	MX (kip'in)	MY (kip'in)	MZ (kip'in)
27	-	-	-1.24E 3	-	-	-
41	-	-	-2.24E 3	-	-	-

Plate	Type	Direction	Fa	Fb	X1 (ft)	Y1 (ft)	X2 (ft)	Y2 (ft)
58	PRE psf	GZ	-10.224					
59	PRE psf	GZ	-10.224					

Node	L/C	X (in)	Y (in)	Z (in)	Resultant (in)	rX (rad)	rY (rad)	rZ (rad)
1	3:DL+LZ	0.000	0.000	0.000	0.000	-0.004	-0.001	-0.000
2	3:DL+LZ	0.000	0.011	0.000	0.011	-0.004	-0.001	0.000
3	3:DL+LZ	0.000	0.000	0.000	0.000	-0.002	-0.001	-0.000
4	3:DL+LZ	0.000	0.000	0.000	0.000	-0.005	-0.000	-0.000
5	3:DL+LZ	0.000	0.000	0.000	0.000	-0.005	-0.000	-0.000
6	3:DL+LZ	0.000	0.000	0.000	0.000	-0.005	-0.000	-0.000
7	3:DL+LZ	0.000	0.000	0.000	0.000	-0.005	-0.000	0.001
8	3:DL+LZ	0.000	0.002	0.000	0.002	-0.005	-0.000	0.001
9	3:DL+LZ	0.002	-0.001	-0.054	0.054	-0.003	-0.001	-0.000
10	3:DL+LZ	-0.002	0.011	-0.054	0.055	-0.003	-0.001	0.000
11	3:DL+LZ	0.001	-0.000	-0.025	0.025	-0.002	-0.001	-0.000
12	3:DL+LZ	-0.000	-0.000	-0.053	0.053	-0.002	-0.000	0.000
13	3:DL+LZ	0.001	-0.002	-0.051	0.051	-0.001	-0.000	-0.000
14	3:DL+LZ	-0.000	0.000	-0.051	0.051	-0.001	-0.000	0.000
15	3:DL+LZ	-0.010	-0.000	-0.052	0.053	-0.002	-0.000	0.001
16	3:DL+LZ	-0.010	0.002	-0.052	0.053	-0.002	-0.000	0.001
17	3:DL+LZ	0.006	-0.001	-0.255	0.256	-0.003	-0.002	-0.000



Software licensed to INEEL

Job No EDF-5017	Sheet No 42 of 138	Rev
Part		
Ref		
By R Lippert	Date 10-Mar-04	Chd
Client	File TankShield2.std	Date/Time 30-Jun-2004 15:45

Job Title **V-TANK CONTENTS REMOVAL -- CONSOLIDATION TANK SHIELDING**

Node Displacements Cont...

Node	L/C	X (in)	Y (in)	Z (in)	Resultant (in)	rX (rad)	rY (rad)	rZ (rad)
18	3:DL+LZ	0.000	0.010	-0.255	0.256	-0.003	-0.002	-0.000
19	3:DL+LZ	0.006	-0.001	-0.057	0.058	-0.000	-0.001	-0.000
20	3:DL+LZ	0.001	-0.001	-0.055	0.055	-0.001	-0.001	0.000
21	3:DL+LZ	0.006	-0.002	-0.052	0.053	-0.000	-0.001	-0.000
22	3:DL+LZ	0.001	-0.001	-0.052	0.052	-0.000	-0.001	0.000
23	3:DL+LZ	-0.049	-0.000	-0.054	0.073	-0.001	-0.000	0.001
24	3:DL+LZ	-0.049	0.002	-0.053	0.072	-0.001	-0.000	0.001
25	3:DL+LZ	-0.000	0.005	-0.054	0.054	-0.003	-0.001	-0.000
26	3:DL+LZ	0.000	-0.001	-0.051	0.051	-0.001	-0.000	-0.000
27	3:DL+LZ	-0.000	-0.000	-0.053	0.053	-0.001	-0.000	0.000
28	3:DL+LZ	-0.010	0.001	-0.052	0.053	-0.001	-0.000	0.001
29	3:DL+LZ	-0.001	0.011	-0.158	0.158	-0.003	-0.001	-0.000
30	3:DL+LZ	0.003	-0.001	-0.158	0.158	-0.003	-0.001	-0.000
31	3:DL+LZ	0.003	-0.001	-0.059	0.059	-0.000	-0.001	-0.000
32	3:DL+LZ	0.000	-0.001	-0.059	0.059	0.000	-0.001	-0.000
33	3:DL+LZ	0.003	-0.001	-0.056	0.056	-0.000	-0.001	-0.000
34	3:DL+LZ	0.000	-0.001	-0.056	0.056	0.000	-0.001	-0.000
35	3:DL+LZ	-0.030	-0.000	-0.062	0.069	0.001	-0.000	0.001
36	3:DL+LZ	-0.030	0.002	-0.061	0.068	0.001	-0.000	0.001
39	3:DL+LZ	0.003	0.005	-0.255	0.256	-0.003	-0.002	-0.000
40	3:DL+LZ	0.003	-0.001	-0.052	0.052	-0.000	-0.001	-0.000
41	3:DL+LZ	0.001	-0.001	-0.053	0.054	-0.001	-0.001	0.000
42	3:DL+LZ	-0.049	0.001	-0.053	0.073	-0.001	-0.000	0.001
43	3:DL+LZ	0.004	0.005	-0.334	0.334	-0.003	-0.003	-0.000
44	3:DL+LZ	0.004	-0.001	-0.075	0.075	-0.001	-0.002	-0.000
45	3:DL+LZ	-0.005	-0.000	-0.054	0.054	-0.001	-0.001	0.000
46	3:DL+LZ	-0.066	0.001	-0.054	0.085	-0.001	-0.000	0.001

Reactions

Node	L/C	Horizontal			Moment		
		FX (lb)	FY (lb)	FZ (lb)	MX (kip'in)	MY (kip'in)	MZ (kip'in)
1	3:DL+LZ	-18.463	1.93E 3	166.800	0.000	0.000	0.000
2	3:DL+LZ	36.057	0.000	156.806	0.000	0.000	0.000
3	3:DL+LZ	1.754	565.856	36.108	0.000	0.000	0.000
4	3:DL+LZ	-21.894	804.823	698.258	0.000	0.000	0.000
5	3:DL+LZ	-7.139	4.16E 3	915.221	0.000	0.000	0.000
6	3:DL+LZ	-35.035	0.000	905.406	0.000	0.000	0.000
7	3:DL+LZ	20.575	122.873	662.595	0.000	0.000	0.000
8	3:DL+LZ	24.145	0.000	658.484	0.000	0.000	0.000



Software licensed to INEEL

Job No
EDF-5017

Sheet No
43 of 138

Rev

Part

Job Title **V-TANK CONTENTS REMOVAL -- CONSOLIDATION TANK SHIELDING**

Ref

By **R Lippert** Date **10-Mar-04** Chd

Client

File **TankShield2.std**

Date/Time **30-Jun-2004 15:45**

Failure Ratio

Beam	Analysis Property	New Property	Ratio	Ay (in ²)	Az (in ²)	Ax (in ²)	Dw (ft)	Bf (ft)	Iz (in ⁴)	Iy (in ⁴)	Ix (in ⁴)
1	TUB20203	TUB20203	0.175	0.750	0.750	1.270	0.167	0.167	0.700	0.700	1.200
2	TUB20203	TUB20203	0.000	0.750	0.750	1.270	0.167	0.167	0.700	0.700	1.200
3	TUB20203	TUB20203	0.041	0.750	0.750	1.270	0.167	0.167	0.700	0.700	1.200
4	TUB20203	TUB20203	0.495	0.750	0.750	1.270	0.167	0.167	0.700	0.700	1.200
5	TUB20203	TUB20203	0.710	0.750	0.750	1.270	0.167	0.167	0.700	0.700	1.200
6	TUB20203	TUB20203	0.598	0.750	0.750	1.270	0.167	0.167	0.700	0.700	1.200
7	TUB20203	TUB20203	0.499	0.750	0.750	1.270	0.167	0.167	0.700	0.700	1.200
8	TUB20203	TUB20203	0.438	0.750	0.750	1.270	0.167	0.167	0.700	0.700	1.200
9	TUB20203	TUB20203	0.044	0.750	0.750	1.270	0.167	0.167	0.700	0.700	1.200
10	TUB20203	TUB20203	0.000	0.750	0.750	1.270	0.167	0.167	0.700	0.700	1.200
11	TUB20203	TUB20203	0.096	0.750	0.750	1.270	0.167	0.167	0.700	0.700	1.200
12	TUB20203	TUB20203	0.197	0.750	0.750	1.270	0.167	0.167	0.700	0.700	1.200
13	TUB20203	TUB20203	0.151	0.750	0.750	1.270	0.167	0.167	0.700	0.700	1.200
14	TUB20203	TUB20203	0.167	0.750	0.750	1.270	0.167	0.167	0.700	0.700	1.200
15	TUB20203	TUB20203	0.168	0.750	0.750	1.270	0.167	0.167	0.700	0.700	1.200
16	TUB20203	TUB20203	0.159	0.750	0.750	1.270	0.167	0.167	0.700	0.700	1.200
17	TUBE	TUB E	0.000	1.128	0.564	1.551	0.250	0.125	1.683	0.533	1.241
18	TUBE	TUB E	0.000	1.128	0.564	1.551	0.250	0.125	1.683	0.533	1.241
19	TUBE	TUB E	0.000	1.128	0.564	1.551	0.250	0.125	1.683	0.533	1.241
20	TUBE	TUB E	0.000	1.128	0.564	1.551	0.250	0.125	1.683	0.533	1.241
21	TUBE	TUB E	0.000	1.128	0.564	1.551	0.250	0.125	1.683	0.533	1.241
22	TUBE	TUB E	0.000	1.128	0.564	1.551	0.250	0.125	1.683	0.533	1.241
23	TUBE	TUB E	0.000	1.128	0.564	1.551	0.250	0.125	1.683	0.533	1.241
24	TUBE	TUB E	0.000	1.128	0.564	1.551	0.250	0.125	1.683	0.533	1.241
25	TUBE	TUB E	0.049	1.128	0.564	1.551	0.250	0.125	1.683	0.533	1.241
26	TUBE	TUB E	0.105	1.128	0.564	1.551	0.250	0.125	1.683	0.533	1.241
27	TUB20203	TUB20203	0.000	0.750	0.750	1.270	0.167	0.167	0.700	0.700	1.200
28	TUB20203	TUB20203	0.049	0.750	0.750	1.270	0.167	0.167	0.700	0.700	1.200
29	TUB20203	TUB20203	0.063	0.750	0.750	1.270	0.167	0.167	0.700	0.700	1.200
30	TUB20203	TUB20203	0.109	0.750	0.750	1.270	0.167	0.167	0.700	0.700	1.200
31	TUB20203	TUB20203	0.094	0.750	0.750	1.270	0.167	0.167	0.700	0.700	1.200
32	TUB20203	TUB20203	0.125	0.750	0.750	1.270	0.167	0.167	0.700	0.700	1.200
33	TUB20203	TUB20203	0.105	0.750	0.750	1.270	0.167	0.167	0.700	0.700	1.200
34	TUB20203	TUB20203	0.107	0.750	0.750	1.270	0.167	0.167	0.700	0.700	1.200
35	TUB20203	TUB20203	0.000	0.750	0.750	1.270	0.167	0.167	0.700	0.700	1.200
36	TUB20203	TUB20203	0.000	0.750	0.750	1.270	0.167	0.167	0.700	0.700	1.200
37	TUB20203	TUB20203	0.000	0.750	0.750	1.270	0.167	0.167	0.700	0.700	1.200
38	TUB20203	TUB20203	0.000	0.750	0.750	1.270	0.167	0.167	0.700	0.700	1.200
39	TUB20203	TUB20203	0.000	0.750	0.750	1.270	0.167	0.167	0.700	0.700	1.200
40	TUB20203	TUB20203	0.000	0.750	0.750	1.270	0.167	0.167	0.700	0.700	1.200
41	TUB20203	TUB20203	0.000	0.750	0.750	1.270	0.167	0.167	0.700	0.700	1.200
42	TUB20203	TUB20203	0.000	0.750	0.750	1.270	0.167	0.167	0.700	0.700	1.200
43	TUBE	TUB E	0.050	1.128	0.564	1.551	0.250	0.125	1.683	0.533	1.241
44	TUBE	TUB E	0.061	1.128	0.564	1.551	0.250	0.125	1.683	0.533	1.241
45	TUB20203	TUB20203	0.000	0.750	0.750	1.270	0.167	0.167	0.700	0.700	1.200
46	TUB20203	TUB20203	0.000	0.750	0.750	1.270	0.167	0.167	0.700	0.700	1.200



Software licensed to INEEL

Job No EDF-5017	Sheet No 44 of 138	Rev
Part		
Ref		
By R Lippert	Date 10-Mar-04	Chd
Client	File TankShield2.std	Date/Time 30-Jun-2004 15:45

Failure Ratio Cont...

Beam	Analysis Property	New Property	Ratio	Ay (in ²)	Az (in ²)	Ax (in ²)	Dw (ft)	Bf (ft)	Iz (in ⁴)	Iy (in ⁴)	Ix (in ⁴)
47	TUBE	TUB E	0.137	1.128	0.564	1.551	0.250	0.125	1.683	0.533	1.241
48	TUBE	TUB E	0.100	1.128	0.564	1.551	0.250	0.125	1.683	0.533	1.241
52	TUB20203	TUB20203	0.000	0.750	0.750	1.270	0.167	0.167	0.700	0.700	1.200
53	TUB20203	TUB20203	0.000	0.750	0.750	1.270	0.167	0.167	0.700	0.700	1.200
55	TUB20203	TUB20203	0.000	0.750	0.750	1.270	0.167	0.167	0.700	0.700	1.200
56	TUB20203	TUB20203	0.000	0.750	0.750	1.270	0.167	0.167	0.700	0.700	1.200

Attachment 3
Tank Support Frame Design

TANK SUPPORT FRAME

The support frame (or skid) will be constructed from HSS 8x8x1/4, allowing it to be lifted & placed at the desired location in one piece. Lifting lugs will be provided at each corner of the skid.

See Figure 3 for frame layout & dimensions. Figure 4 shows how the tanks, containment pan & shielding π 's will be located on the frame. Also see Attachment 7.

The support skid is analyzed using "RAM Advance" (Ref. 6). Analysis input & output are attached.

Loads

tank wt - $vol = 8000 \text{ gal} = 1069.4 \text{ ft}^3$

for content wt use $SG = 1.0$

$$\text{content wt} = 1.0(62.4)(1069.4) = 66730 \#$$

$$\text{assume tank wt (empty)} = 11000 \# \begin{matrix} \text{(w/ accessories)} \\ \text{(see Attachment 6)} \end{matrix}$$

$$\text{total wt} = 66730 + 11000 = 77730 \# \text{ say } 80 \text{ k}$$

consider 4 legs per tank,

$$\text{wt on each leg} = 80/4 = 20 \text{ k full tank}$$

$$= 11 \text{ k}/4 = 2.75 \text{ k empty tank}$$

containment pan - see Attachment 1

$$3/16 \text{ } \pi \text{ wt} = 7.66 \text{ psf}$$

$$\text{if tank leaks, liquid wt} = 3'(62.4) = 187 \text{ psf}$$

$$\text{total wt} = 7.66 + 187 = 195 \text{ psf}$$

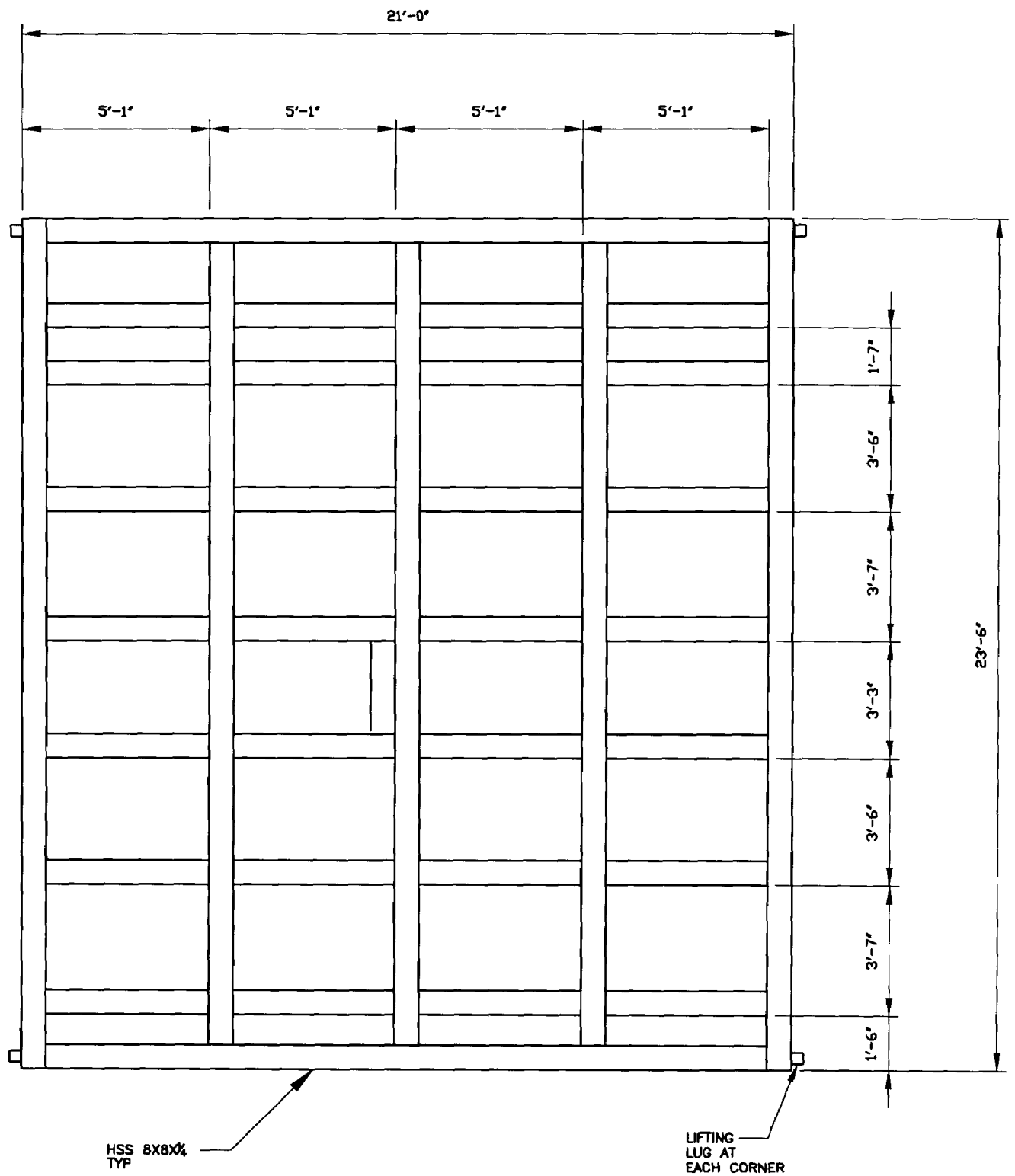

FIGURE 3
TANK SUPPORT FRAME

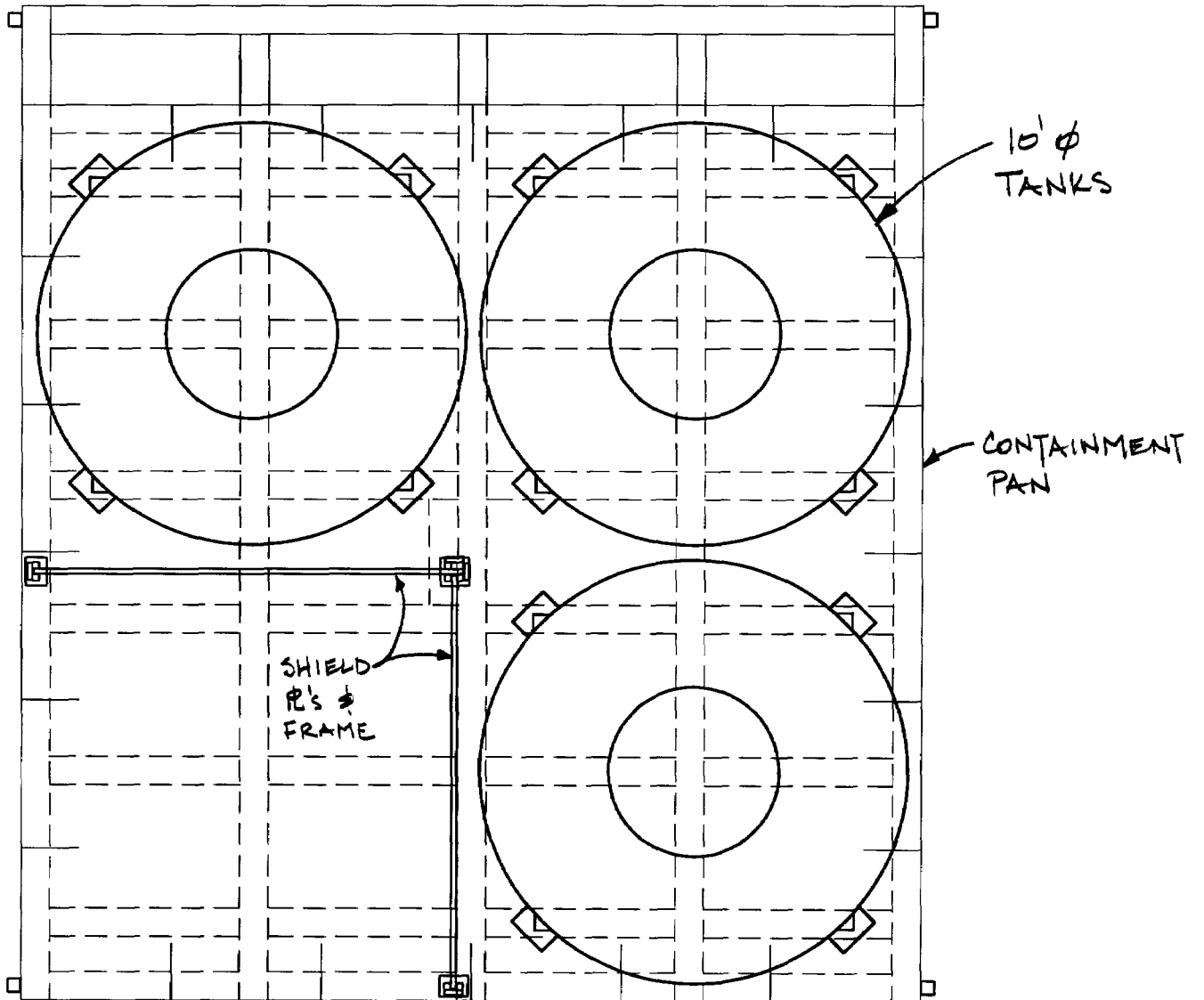

FIGURE 4
TANK SUPPORT FRAME

shield panels & frame - See Attachment 2
 conservatively use max. reaction at ea. base
 plate location, $R = 5.5^k$ at 3 places

Load Cases

DL = selfwt of skid & pan floor

TK = wt of tanks full

SC = wt of containment pan full (tank has leaked)

TK1 = tank 1 is empty, other tanks full

TK2 = tank 2 is empty, other tanks full

TK3 = tank 3 is empty, other tanks full

SP = shield panel wt

Load Combinations

1. DL + TK + SP
2. DL + SC + TK1 + SP
3. DL + SC + TK2 + SP
4. DL + SC + TK3 + SP

Supports

Since the skid will be placed on soil, vertical soil spring supports are located at each node. Spring constants are determined using a subgrade modulus value times the tributary area for each node. Soil is ML or CL, so representative subgrade modulus $K = 150$ pci from

360R-12
ACI

MANUAL OF CONCRETE PRACTICE

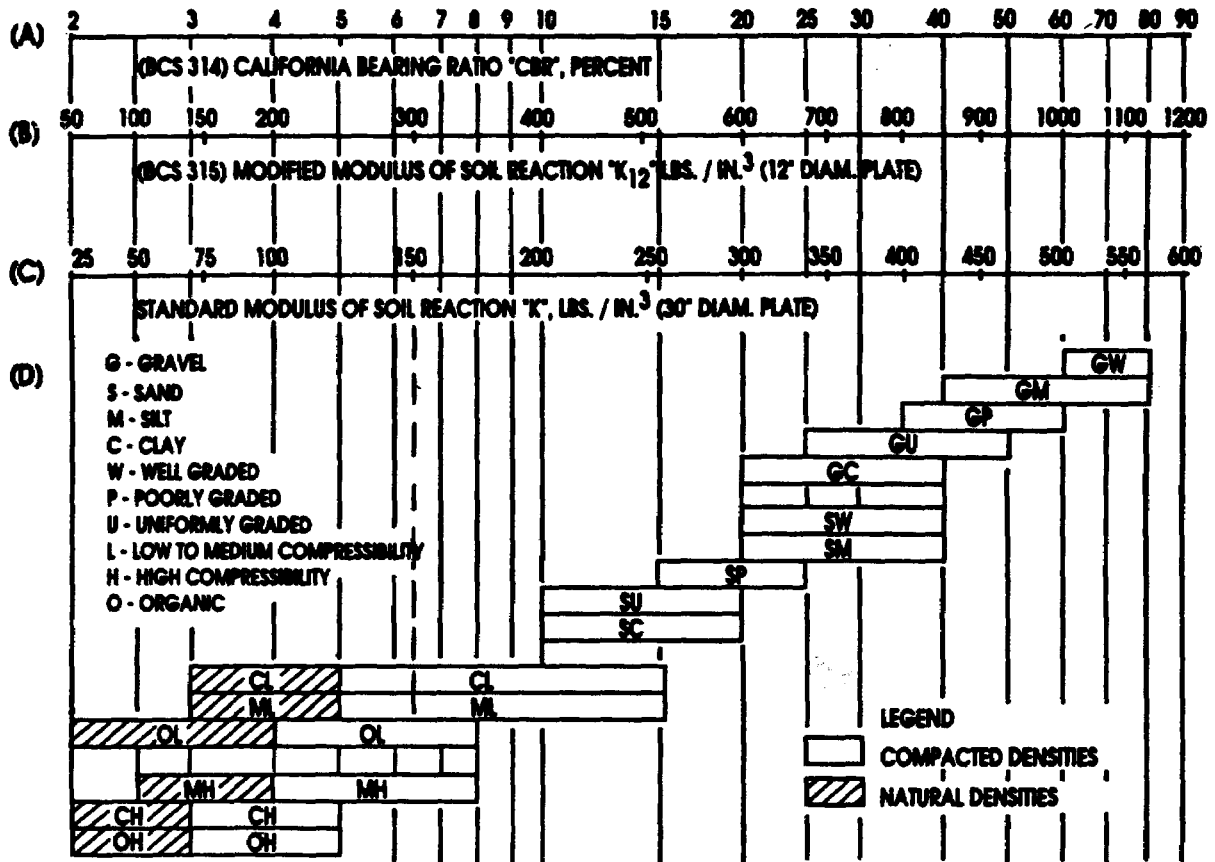

Note: Comparison of soil type to "K", particularly in the "L" and "H" Groups, should generally be made in the lower range of the soil type.

Fig. 3.3.5—Interrelationship of soil classifications and strengths (from Reference 23)

Fig. 3.3.5 of ACI 360 R (Ref. 13). See p.66 of input data for spring constants used.

Results

From the code check, the greatest stress (or design) ratio (calc'd stress/allowable stress) is 0.37 in Beam #70 for LC4. All member stress ratios are < 1.0, so skid is OK using HSS 8x8x1/4.

Greatest vertical displacement = 0.146" at node #25 for LC4. This magnitude of displacement is negligible.

SKID LIFTING LUG

Locate a lifting lug at ea. corner of skid.

Assume skid to be lifted with containment pan & shield & frame.

$$\begin{array}{r} \text{Skid wt} \approx 8600\# \\ \text{Pan wt} \approx 6000\# \\ \text{Frame wt} \approx 500\# \\ \hline 15100\# \end{array}$$

Each lug to support
1/2 of load w/impact (25%)

$$P_v = 1.25(15.1)/2 = 9.44^k$$

assume $\alpha = 45^\circ$, then

$$P = 13.3^k \quad \neq \quad P_h = 9.44^k$$

see Ref 2 for AISC references

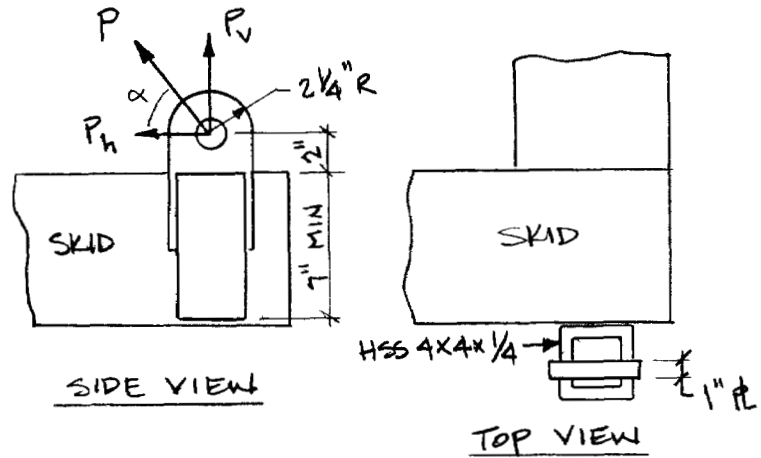

Try 1" x 4 1/2" bar (A36) for lug w/ 1 1/2" ϕ hole for shackle,
& HSS 4x4x1/4 for attachment of lug to skid.

Check Bearing

$$F_p = .9 F_y = .9(36) = 32.4 \text{ ksi} \quad (\text{AISC JB})$$

$$\text{req'd brg area} = 13.3/32.4 = 0.41 \text{ in}^2$$

for 1" bar, min. shackle dia = $0.41/1 = 0.41$ " OK since
most likely shackle will be > 0.41 " in dia.

Check Net Area for Tension

$$F_t = 0.45 F_y = .45(36) = 16.2 \text{ ksi} \quad (\text{AISC D3.1})$$

$$f_t = 13.3/(1 \times 4.5 - 1.5) = 4.4 \text{ ksi} < F_t \text{ so OK}$$

$$\text{req'd net area} = 13.3/16.2 = 0.82 \text{ in}^2$$

Check Net Area for Shear & Hoop Tension

$$\text{req'd area} = 2/3(0.82) = 0.55 \text{ in}^2 \quad (\text{AISC D3.2})$$

$$\text{net area of 1" bar} = 1(2.25 - \frac{1.5}{2}) = 1.75 \text{ in}^2 > 0.55 \text{ in}^2 \text{ OK}$$

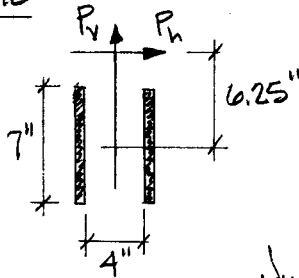
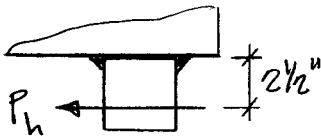
Check HSS to HSS Weld

$$S_h = bd = 7(4) = 28 \text{ in}^2$$

$$S_v = \frac{d^2}{3} = \frac{7^2}{3} = 16.3 \text{ in}^2$$

$$J_w = \frac{d(3b^2 + d^2)}{6} = \frac{7[3(4)^2 + 7^2]}{6} = 113 \text{ in}^3$$

$$f_{th} = \frac{TC}{J_w} = \frac{9.44(6.25)(4/2)}{113} = 1.04 \text{ k/in}$$

$$f_{sh} = \frac{P_h}{A_w} = \frac{9.44}{2(7)} = 0.67 \text{ k/in}$$

$$f_{mh} = \frac{M_h}{S_h} = \frac{9.44(2.5)}{28} = 0.84 \text{ k/in}$$

$$f_{sv} = \frac{P_v}{A_w} = \frac{9.44}{2(7)} = 0.67 \text{ k/in}$$

$$f_{mv} = \frac{M_v}{S_v} = \frac{9.44(2.5)}{16.3} = 1.45 \text{ k/in}$$

$$f_r = [(1.04 + 0.67 + 0.84)^2 + (0.67 + 1.45)^2]^{1/2} = 3.32 \text{ k/in}$$

For E70, allowable stress on 1" weld is

$$f_a = 0.3(70)(1)(0.707) = 14.8 \text{ k/in}$$

$$\therefore \text{req'd weld size} = 3.32/14.8 = 0.224" \text{ use min. } 1/4" \text{ fillet}$$

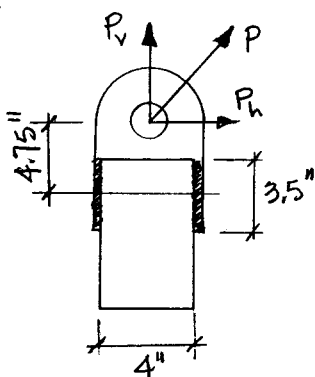
Check Lug Weld

force on weld from moment couple

$$F = \frac{4.75(P_h)}{4} = \frac{4.75(9.44)}{4} = 11.21 \text{ k}$$

$$f_s = \frac{P}{A_w} = \frac{F + P_v}{A_w} = \frac{11.21 + 9.44}{2(3.5)} = 2.95 \text{ k/in}$$





$$\text{req'd weld size} = \frac{2.95}{14.8} = 0.20" \text{ use min } 1/4" \text{ fillet}$$

Design of Welded Structures by OW Blodgett

7.4-6 / Joint Design and Production

(Ref 9)

TABLE 4—Determining Force on Weld

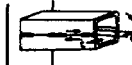
Type of Loading	standard design formula	treating the weld as a line
	stress lbs/in ²	force lbs/in
PRIMARY WELDS transmit entire load at this point		
	$\sigma = \frac{P}{A}$	$f = \frac{P}{A_w}$
	$\sigma = \frac{V}{A}$	$f = \frac{V}{A_w}$
	$\sigma = \frac{M}{S}$	$f = \frac{M}{S_w}$
	$\sigma = \frac{T C}{J}$	$f = \frac{T C}{J_w}$
SECONDARY WELDS hold section together - low stress		
	$\tau = \frac{V A y}{I t}$	$f = \frac{V A y}{I n}$
	$\tau = \frac{T}{2 A t}$	$f = \frac{T}{2 A}$

A = area contained within median line.
(*) applies to closed tubular section only.

6. SIMPLE TENSILE, COMPRESSIVE OR SHEAR LOADS ON WELDS

For a simple tensile, compressive or shear load, the given load is divided by the length of the weld to arrive at the applied unit force, lbs per linear inch of weld. From this force, the proper leg size of fillet weld or throat of groove weld may be found.

7. BENDING OR TWISTING LOADS ON WELDS

The problem here is to determine the properties of the welded connection in order to check the stress in the weld without first knowing its leg size. Some design texts suggest assuming a certain weld-leg size and then calculating the stress in the weld to see if it is overstressed or understressed. If the result is too far off, then the weld-leg size is readjusted.

This has the following disadvantages:

1. Some decision must be made as to what throat section is going to be used to determine the property of the weld. Usually some objection can be raised to any throat section chosen.
2. The resulting stresses must be combined and, for several types of loading, this can be rather complicated.

In contrast, the following is a simple method to determine the correct amount of welding required for adequate strength. This is a method in which the weld is treated as a line, having no area, but a

definite length and outline. This method has the following advantages:

1. It is not necessary to consider throat areas because only a line is considered.
2. Properties of the welded connection are easily found from a table without knowing weld-leg size.
3. Forces are considered on a unit length of weld instead of stresses, thus eliminating the knotty problem of combining stresses.
4. It is true that the stress distribution within a fillet weld is complex, due to eccentricity of the applied force, shape of the fillet, notch effect of the root, etc.; however, these same conditions exist in the actual fillet welds tested and have been recorded as a unit force per unit length of weld.

8. DETERMINING FORCE ON WELD

Visualize the welded connection as a single line, having the same outline as the connection, but no cross-sectional area. Notice, Figure 14, that the area (A_w) of the welded connection now becomes just the length of the weld.

Instead of trying to determine the stress on the weld (this cannot be done unless the weld size is known), the problem becomes a much simpler one of determining the force on the weld.

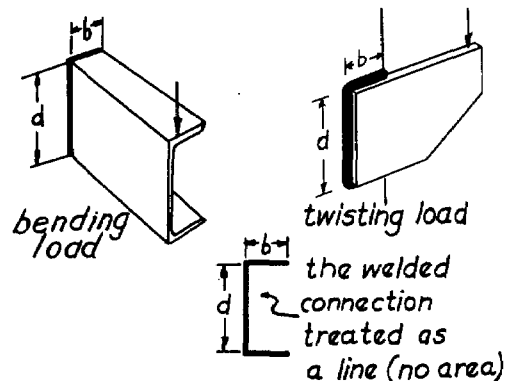

FIG. 14 Treating weld as a line.

By inserting the property of the welded connection treated as a line into the standard design formula used for that particular type of load (see Table 4), the force on the weld may be found in terms of lbs per linear inch of weld.

Example: Bending

Standard design formula (bending stress)	Same formula used for weld (treating weld as a line)
$\sigma = \frac{M}{S} = \frac{\text{lbs}}{\text{in.}^2} \text{ stress}$	$f = \frac{M}{S_w} = \frac{\text{lbs}}{\text{in.}} \text{ force}$

Normally the use of these standard design formulas results in a unit stress, psi; however, when the weld is treated as a line, these formulas result in a force on the weld, lbs per linear inch.

For secondary welds, the weld is not treated as a line, but standard design formulas are used to find the force on the weld, lbs per linear inch.

In problems involving bending or twisting loads Table 5 is used to determine properties of the weld treated as a line. It contains the section modulus (S_w), for bending, and polar moment of inertia (J_w), for twisting, of some 13 typical welded connections with the weld treated as a line.

For any given connection, two dimensions are needed, width (b) and depth (d).

Section modulus (S_w) is used for welds subject to bending loads, and polar moment of inertia (J_w) for twisting loads.

Section moduli (S_w) from these formulas are for maximum force at the top as well as the bottom portions of the welded connections. For the unsymmetrical connections shown in this table, maximum bending force is at the bottom.

If there is more than one force applied to the weld, these are found and combined. All forces which are combined (vectorially added) must occur at the same position in the welded joint.

Determining Weld Size by Using Allowables

Weld size is obtained by dividing the resulting force on the weld found above, by the allowable strength of the particular type of weld used (fillet or groove), obtained from Tables 6 and 7 (steady loads) or Tables 8 and 9 (fatigue loads).

If there are two forces at right angles to each other, the resultant is equal to the square root of the sum of the squares of these two forces.

$$f_r = \sqrt{f_1^2 + f_2^2} \dots\dots\dots(3)$$

If there are three forces, each at right angles to each other, the resultant is equal to the square root of the sum of the squares of the three forces.

$$f_r = \sqrt{f_1^2 + f_2^2 + f_3^2} \dots\dots\dots(4)$$

One important advantage to this method, in addition to its simplicity, is that no new formulas must be used, nothing new must be learned. Assume an engineer has just designed a beam. For strength he has used the standard formula $\sigma = M/S$. Substituting the load on the beam (M) and the property of the beam (S) into this formula, he has found the bending stress (σ). Now, he substitutes the property of the

TABLE 5—Properties of Weld Treated as Line

Outline of Welded Joint b=width d=depth	Bending (about horizontal axis x-x)	Twisting
	$S_w = \frac{d^2}{6} \text{ in.}^2$	$J_w = \frac{d^3}{12} \text{ in.}^3$
	$S_w = \frac{d^2}{3}$	$J_w = \frac{d(3b^2 + d^2)}{6}$
	$S_w = bd$	$J_w = \frac{b^3 + 3bd^2}{6}$
	$S_w = \frac{4bd + d^2}{6} \text{ top}$ $\frac{d^2(4b + d)}{6(2b + d)} \text{ bottom}$	$J_w = \frac{(b+d)^4 - 6b^2d^2}{12(b+d)}$
	$S_w = bd + \frac{d^2}{6}$	$J_w = \frac{(2b+d)^3}{12} - \frac{b^2(b+d)^2}{(2b+d)}$
	$S_w = \frac{2bd + d^2}{3} \text{ top}$ $\frac{d^2(2b + d)}{3(b + d)} \text{ bottom}$	$J_w = \frac{(b+2d)^3}{12} - \frac{d^2(b+d)^2}{(b+2d)}$
	$S_w = bd + \frac{d^2}{3}$	$J_w = \frac{(b + d)^3}{6}$
	$S_w = \frac{2bd + d^2}{3} \text{ top}$ $\frac{d^2(2b + d)}{3(b + d)} \text{ bottom}$	$J_w = \frac{(b+2d)^3}{12} - \frac{d^2(b+d)^2}{(b+2d)}$
	$S_w = \frac{4bd + d^2}{3} \text{ top}$ $\frac{4bd^2 + d^3}{6b + 3d} \text{ bottom}$	$J_w = \frac{d^3(4b + d)}{6(b + d)} + \frac{b^3}{6}$
	$S_w = bd + \frac{d^2}{3}$	$J_w = \frac{b^3 + 3bd^2 + d^3}{6}$
	$S_w = 2bd + \frac{d^2}{3}$	$J_w = \frac{2b^3 + 6bd^2 + d^3}{6}$
	$S_w = \frac{\pi d^2}{4}$	$J_w = \frac{\pi d^3}{4}$
	$I_w = \frac{\pi d}{2} \left(D^2 + \frac{d^2}{2} \right)$ $S_w = \frac{I_w}{c}$ where $c = \frac{\sqrt{D^2 + d^2}}{2}$	

weld, treating it as a line (S_w), obtained from Table 5, into the same formula. Using the same load (M), $f = M/S_w$, he thus finds the force on the weld (f) per linear inch. The weld size is then found by dividing the force on the weld by the allowable force.

Applying System to Any Welded Connection

1. Find the position on the welded connection where the combination of forces will be maximum. There may be more than one which should be considered.
2. Find the value of each of the forces on the welded connection at this point. (a) Use Table 4 for the standard design formula to find the force on the weld. (b) Use Table 5 to find the property of the weld treated as a line.
3. Combine (vectorially) all of the forces on the weld at this point.
4. Determine the required weld size by dividing this resultant value by the allowable force in Tables 6, 7, 8, or 9.

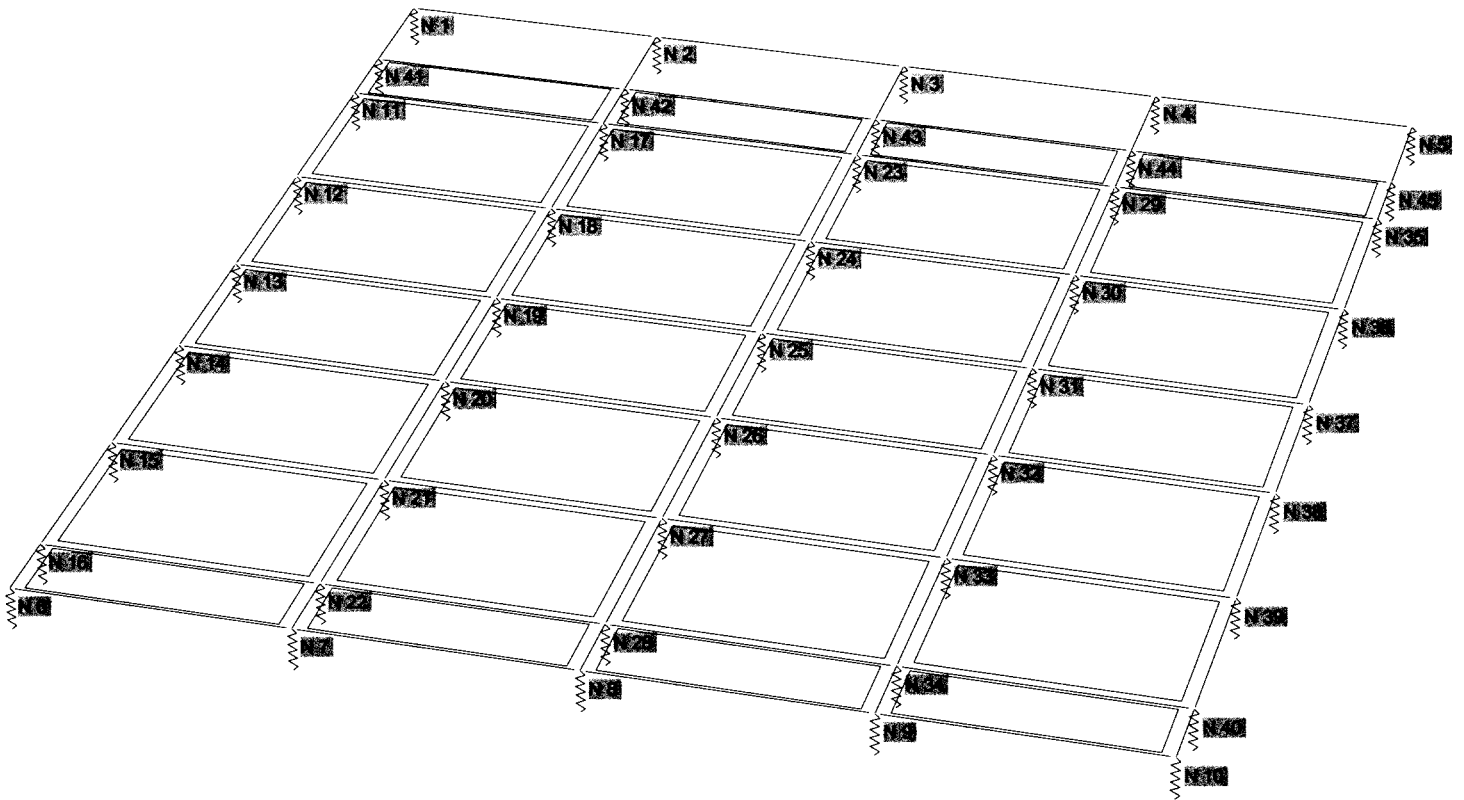
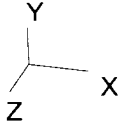

TANK SUPPORT FRAME (SKID)

NODE NUMBERS AND SOIL SPRING SUPPORTS

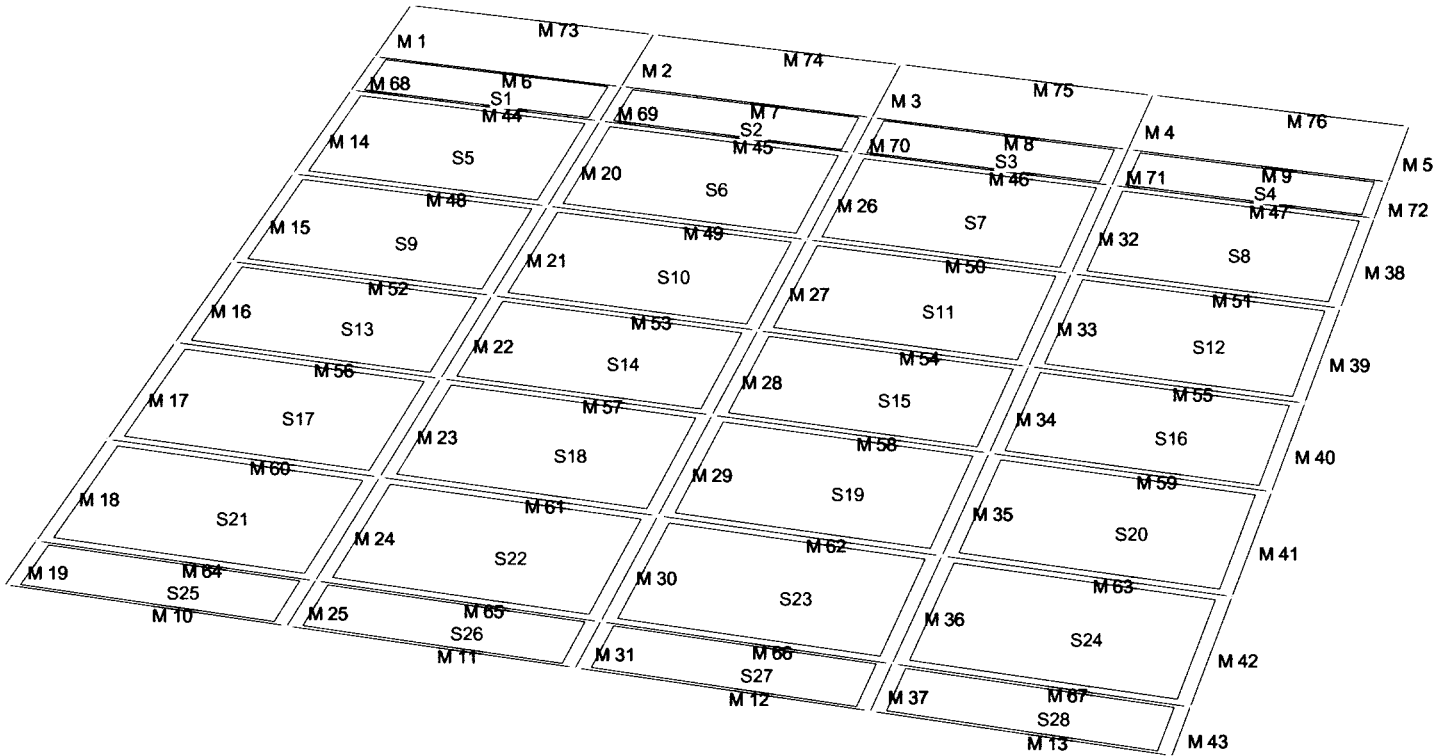
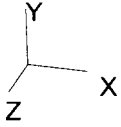

TANK SUPPORT FRAME (SKID)

BEAM AND PLATE NUMBERS

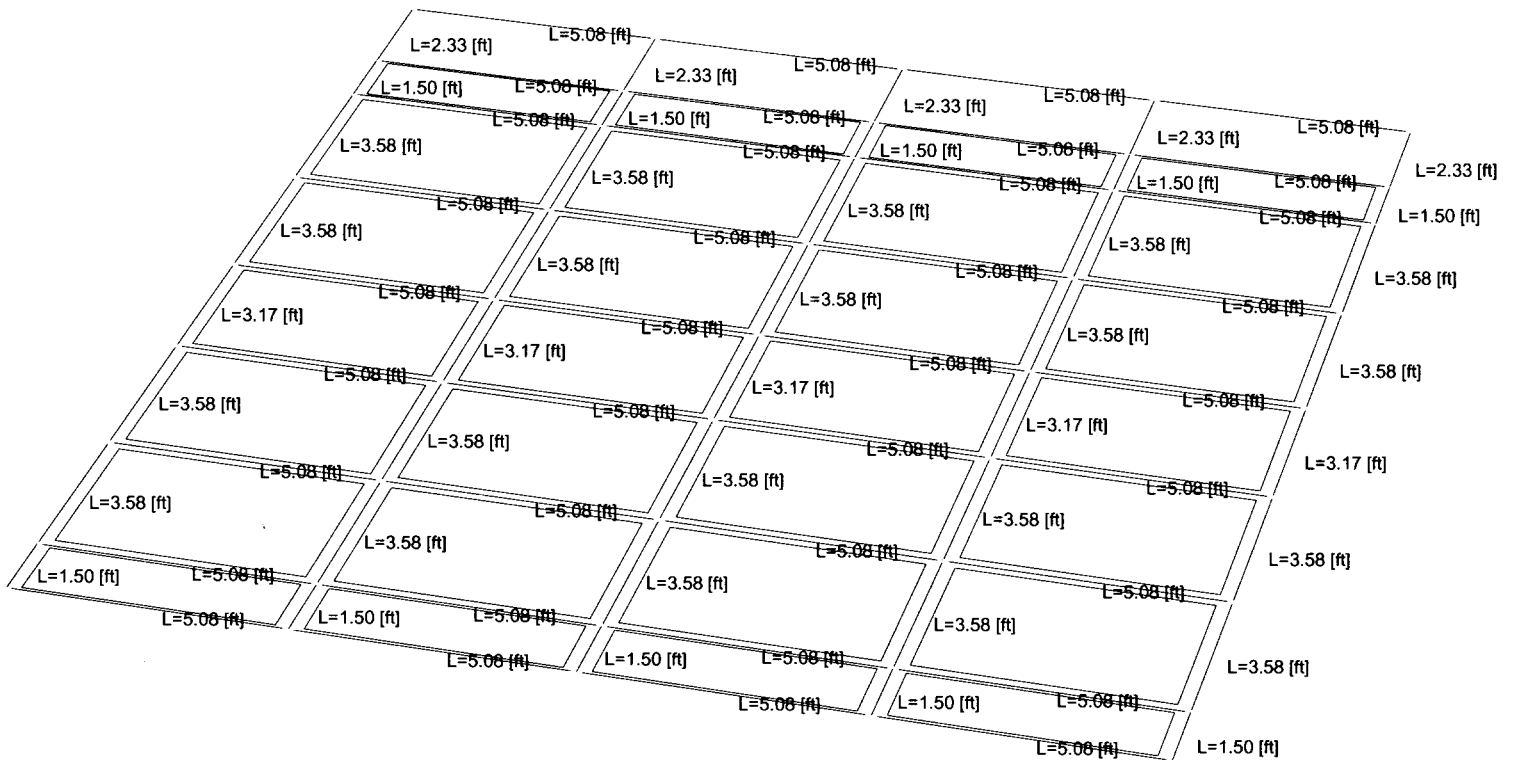
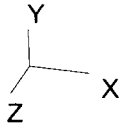

TANK SUPPORT FRAME (SKID)

BEAM LENGTHS

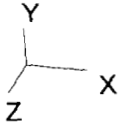

TANK SUPPORT FRAME (SKID)

LOAD CASE SC (Containment Pan Full)

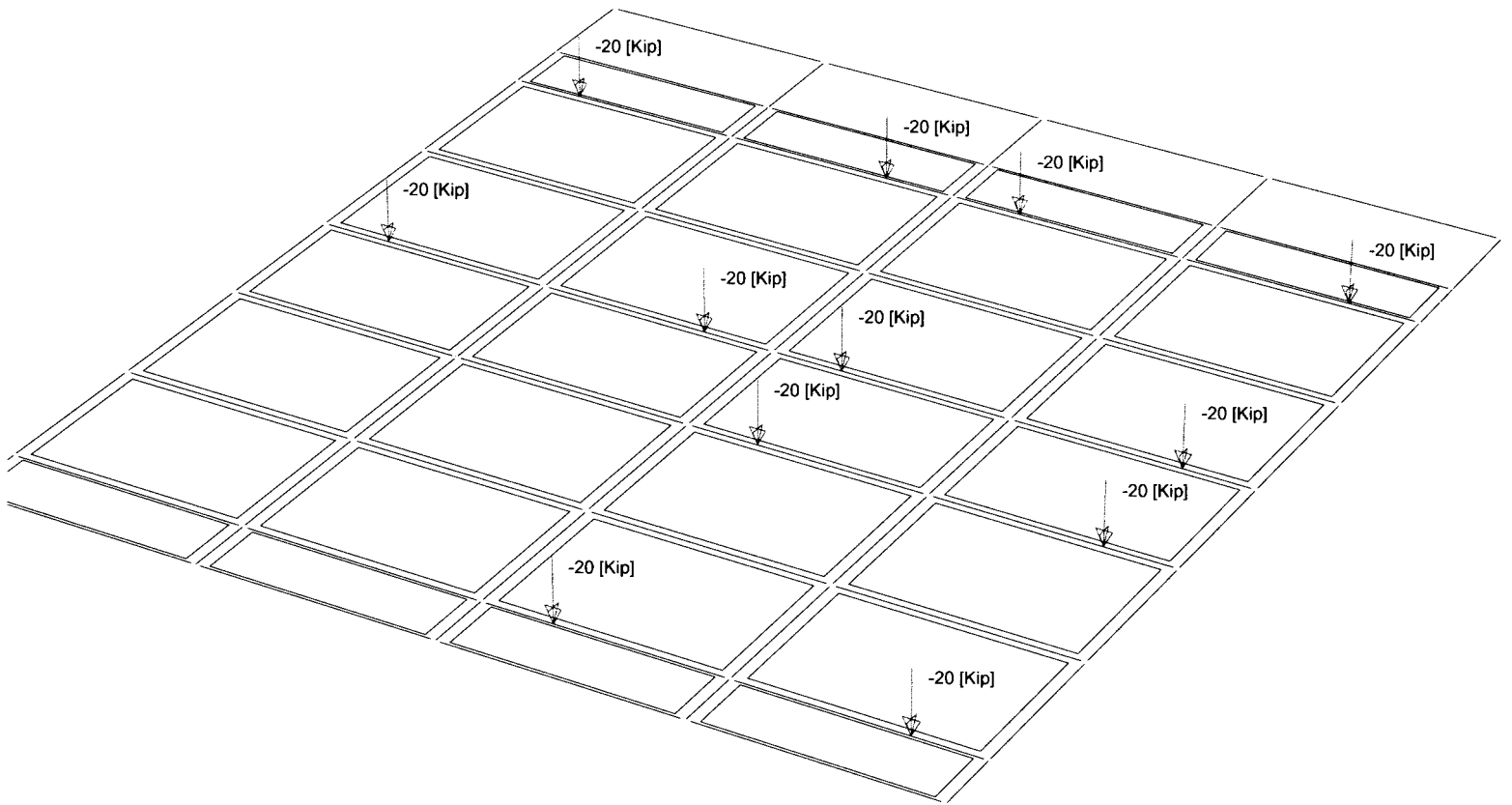
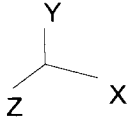

TANK SUPPORT FRAME (SKID)

LOAD CASE TK (Tanks Full)

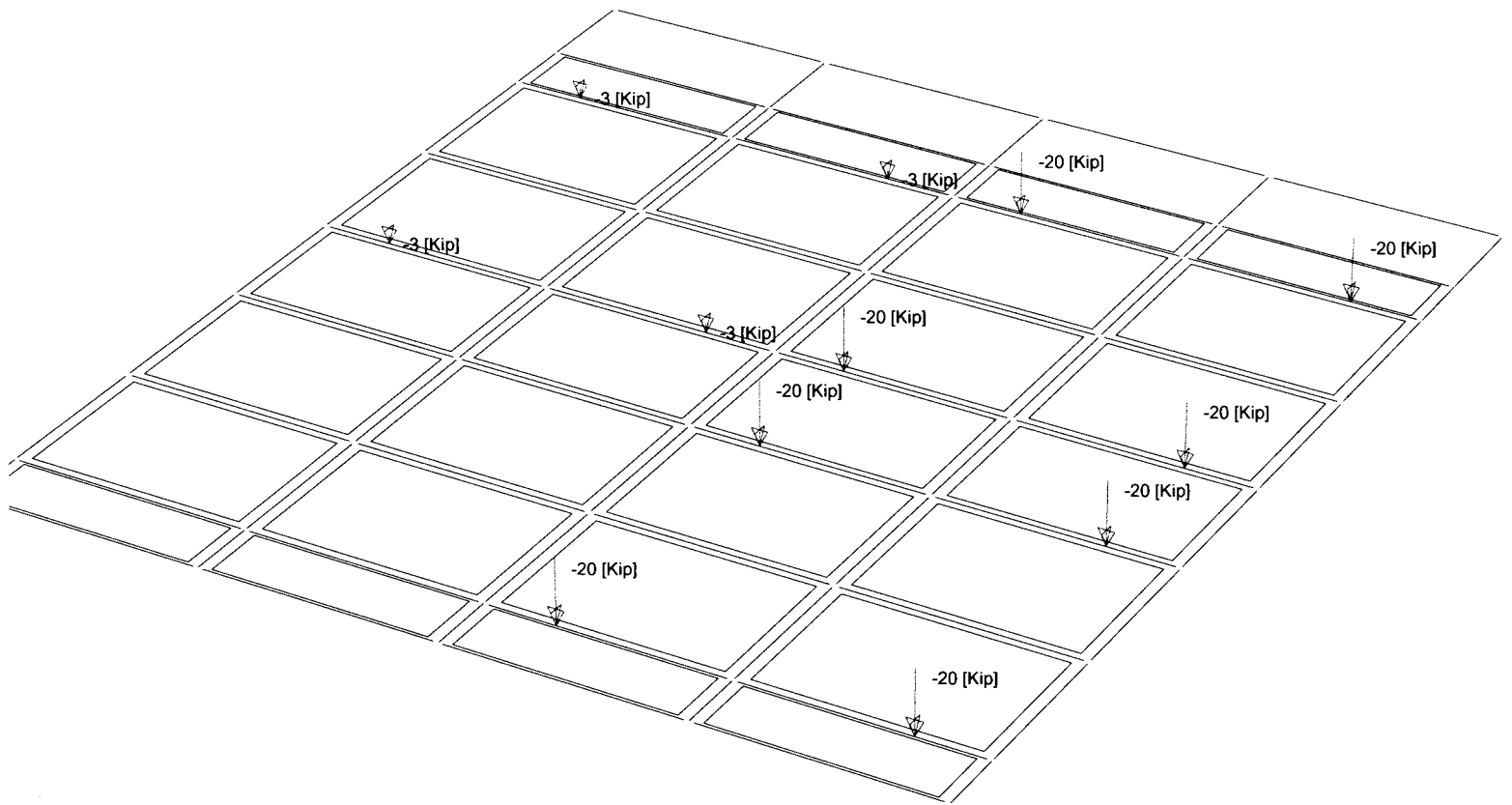
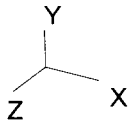

TANK SUPPORT FRAME (SKID)

LOAD CASE TK1 (Tank 1 Empty)

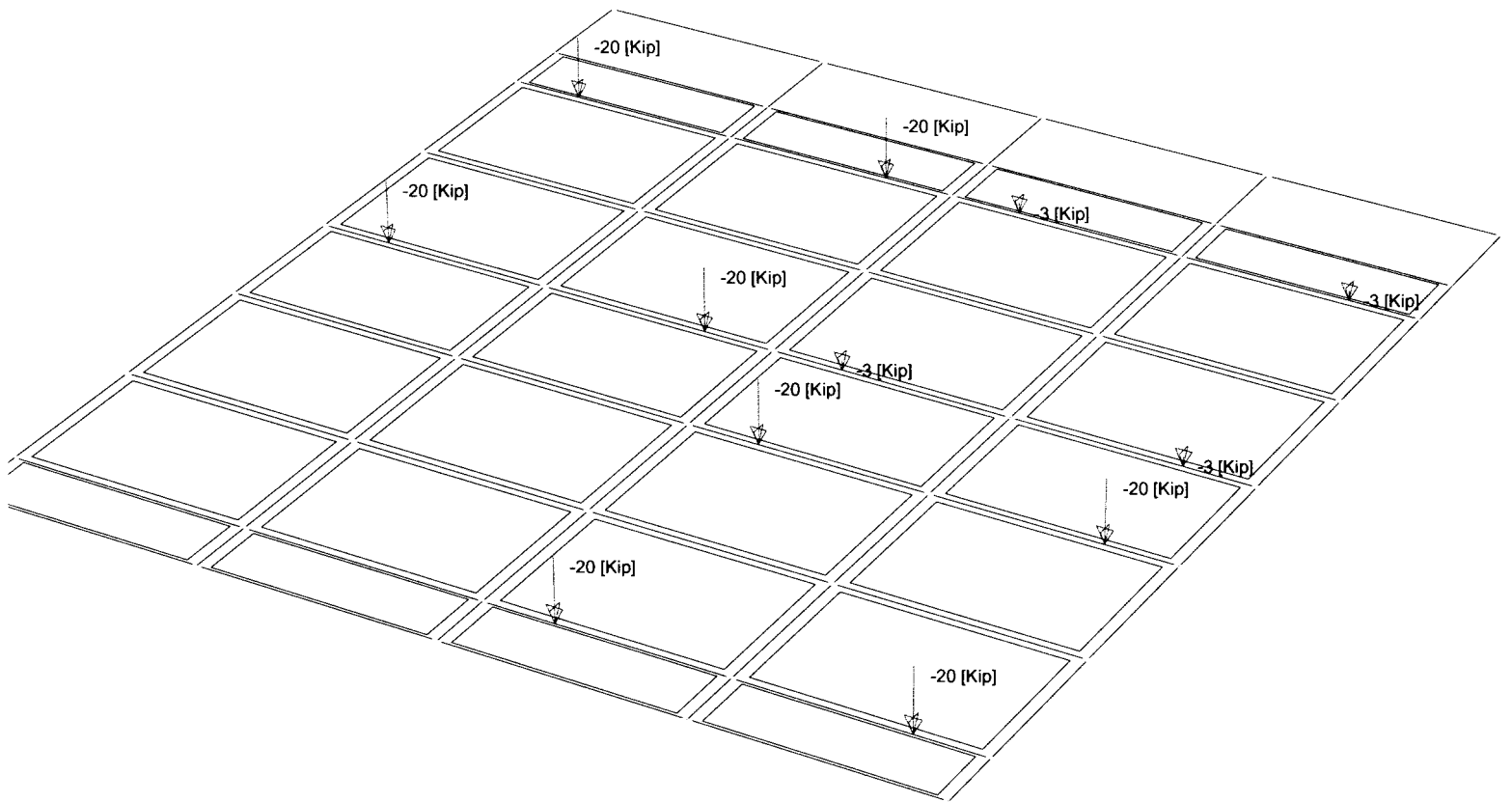
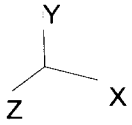

TANK SUPPORT FRAME (SKID)

LOAD CASE TK2 (Tank 2 Empty)

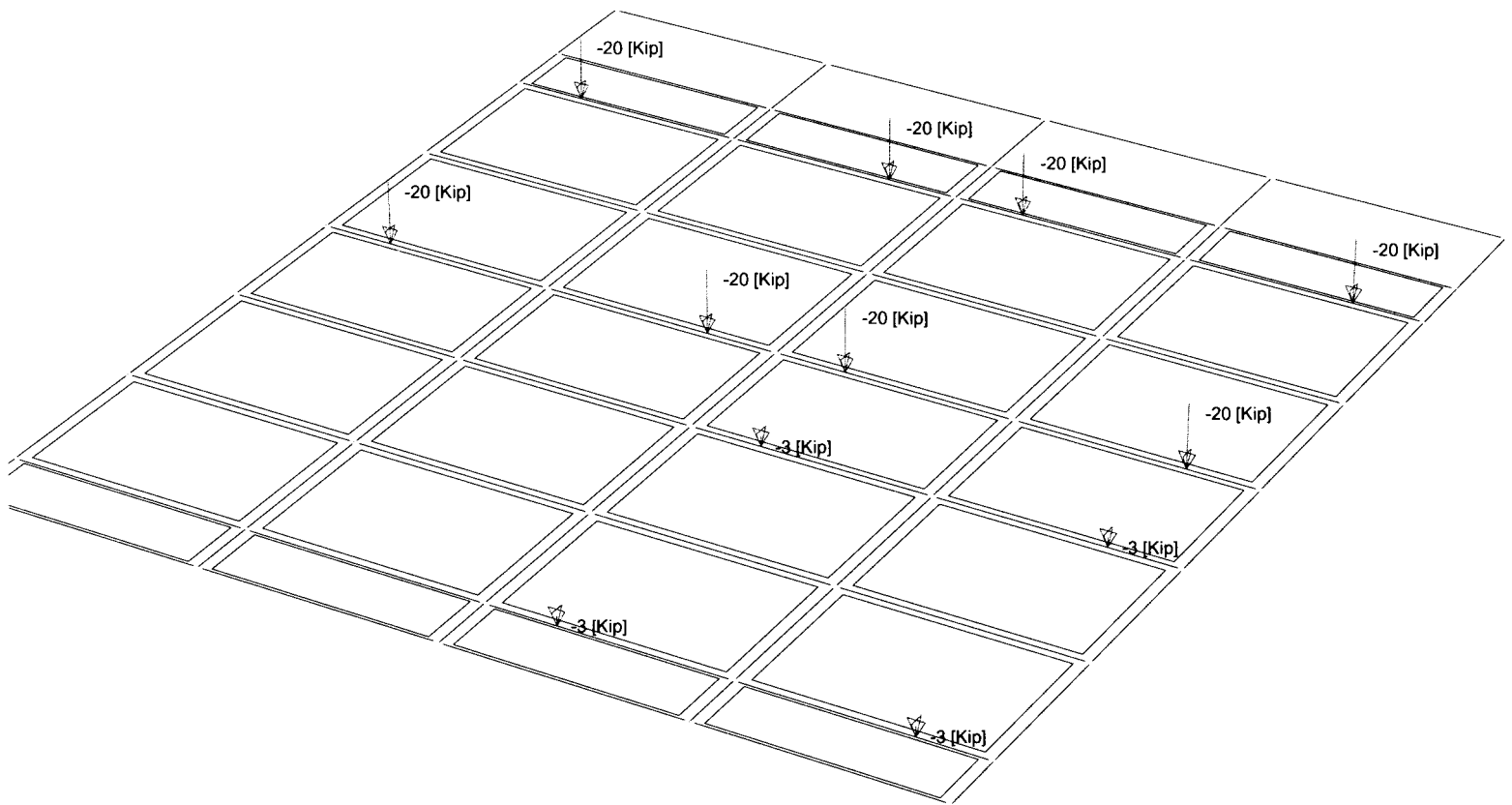
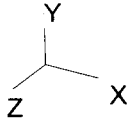

TANK SUPPORT FRAME (SKID)

LOAD CASE TK3 (Tank 3 Empty)

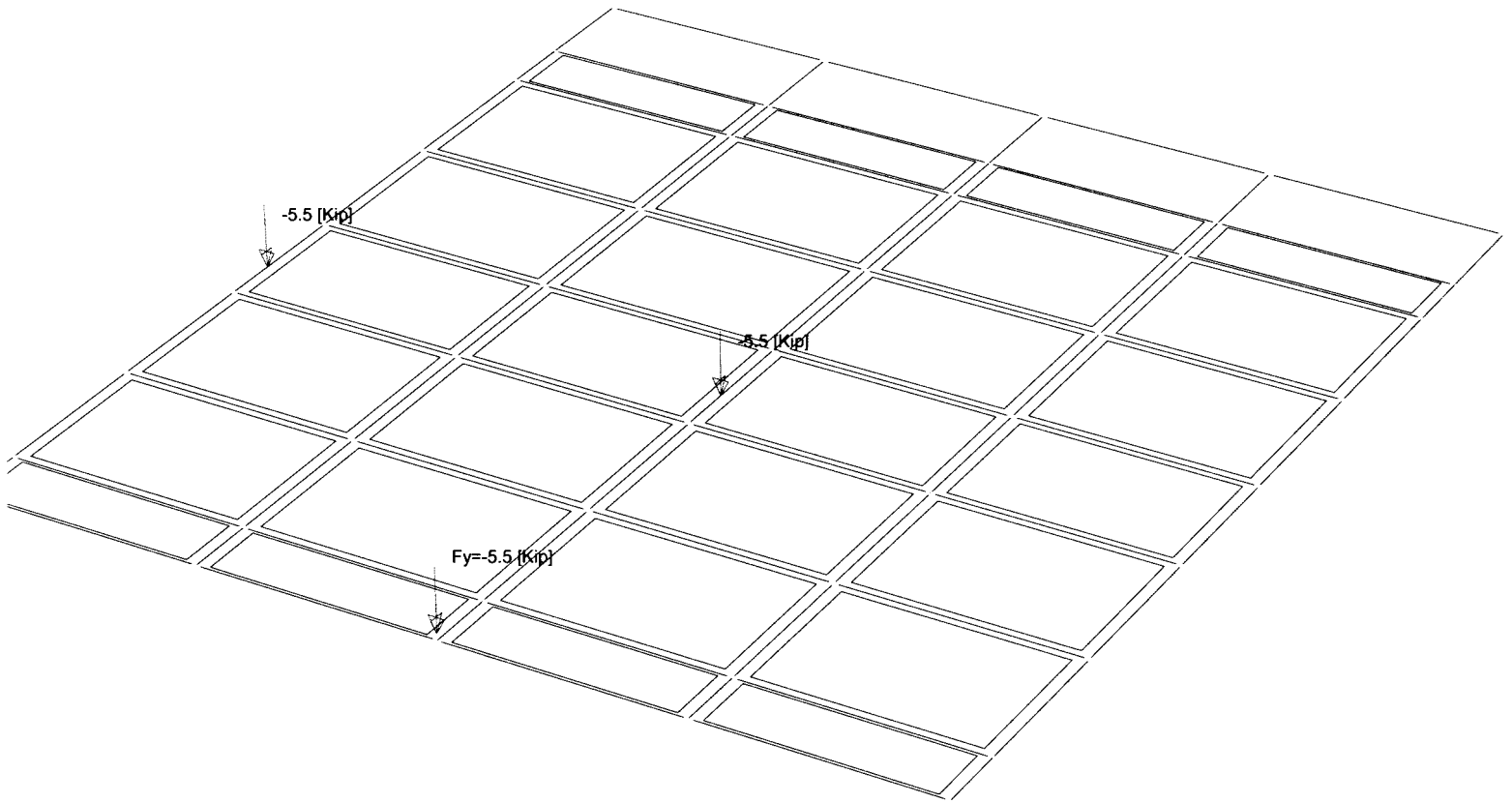
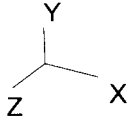

TANK SUPPORT FRAME (SKID)

LOAD CASE SP (Shield Panel Weight)

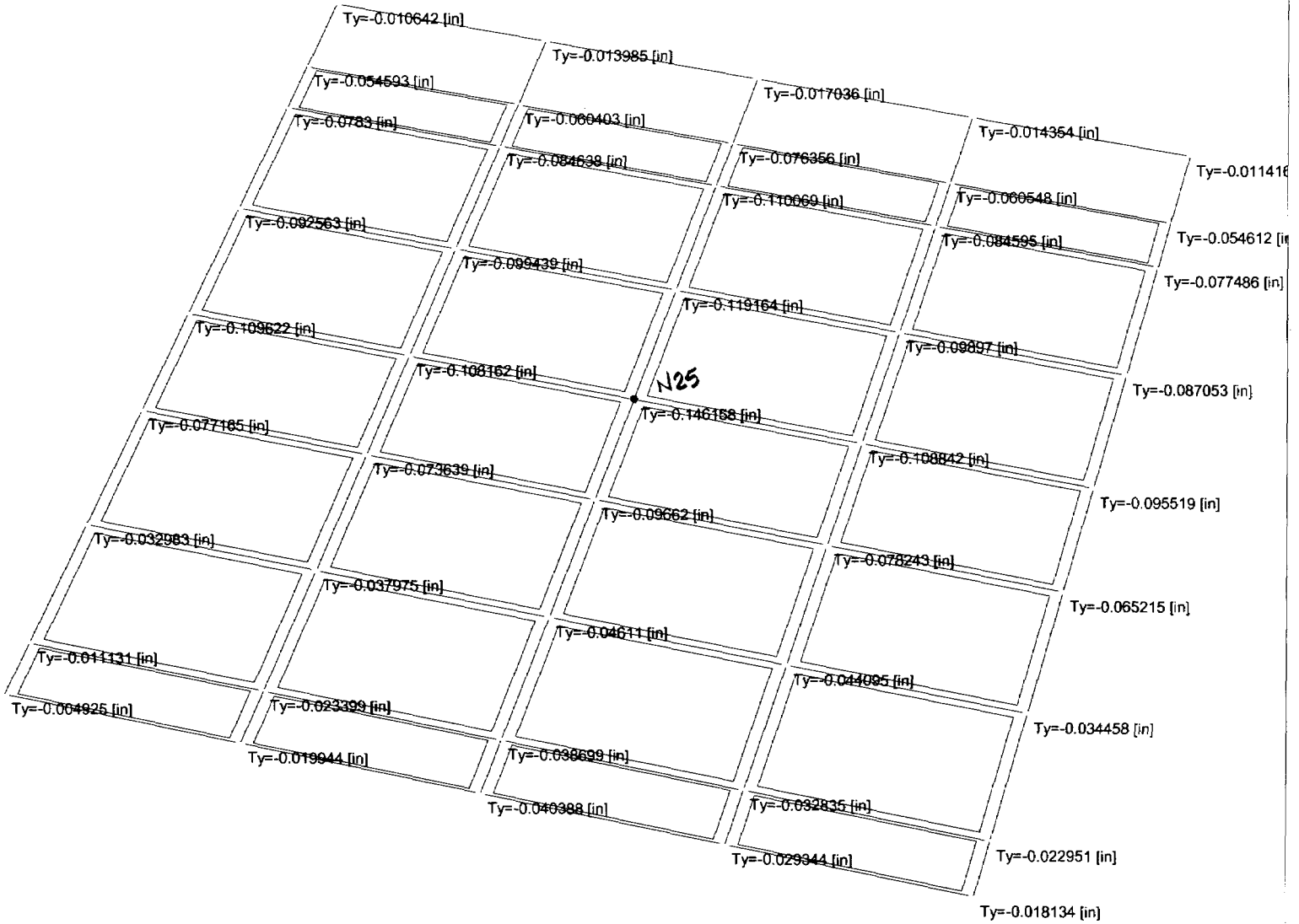
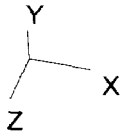

TANK SUPPORT FRAME (SKID)
NODE DISPLACEMENT - LOAD COMBINATION 4

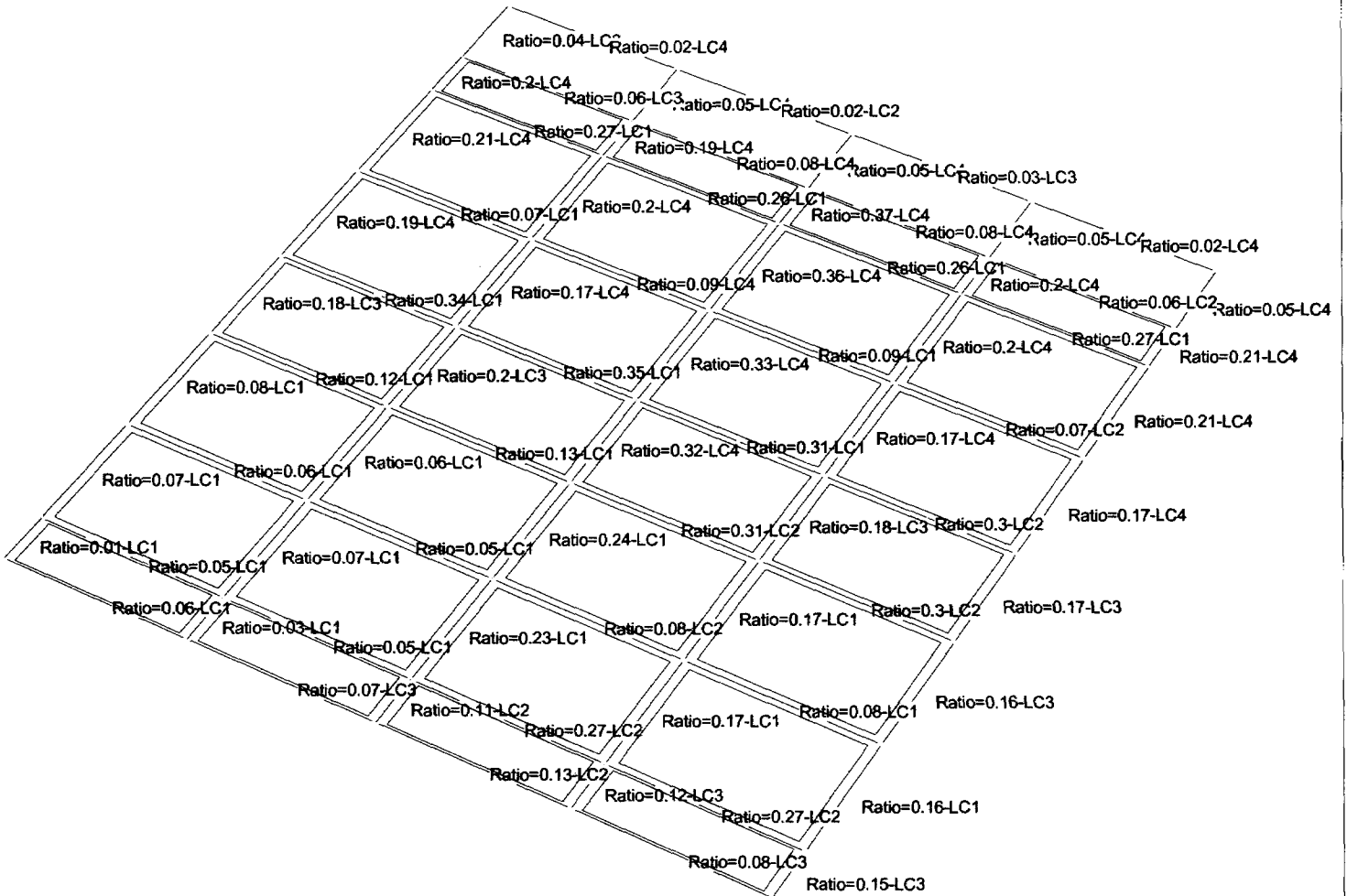
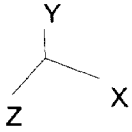

TANK SUPPORT FRAME (SKID)

DESIGN RATIO (Calculated Stress to Allowable Stress)

M O D E L D A T A E C H O

File : C:\Current Projects\V-Tank Analysis\Skid Design\TnkSkid4.AWV
 Units : Lb-in
 Date : 7/13/2004
 Time : 1:14:40 PM

Node	N O D E S			
	X [in]	Y [in]	Z [in]	Floor
1	0	0	0	0
2	61	0	0	0
3	122	0	0	0
4	183	0	0	0
5	244	0	0	0
6	0	0	274	0
7	61	0	274	0
8	122	0	274	0
9	183	0	274	0
10	244	0	274	0
11	0	0	46	0
12	0	0	89	0
13	0	0	132	0
14	0	0	170	0
15	0	0	213	0
16	0	0	256	0
17	61	0	46	0
18	61	0	89	0
19	61	0	132	0
20	61	0	170	0
21	61	0	213	0
22	61	0	256	0
23	122	0	46	0
24	122	0	89	0
25	122	0	132	0
26	122	0	170	0
27	122	0	213	0
28	122	0	256	0
29	183	0	46	0
30	183	0	89	0
31	183	0	132	0
32	183	0	170	0
33	183	0	213	0
34	183	0	256	0
35	244	0	46	0
36	244	0	89	0
37	244	0	132	0
38	244	0	170	0
39	244	0	213	0
40	244	0	256	0
41	0	0	28	0
42	61	0	28	0
43	122	0	28	0
44	183	0	28	0
45	244	0	28	0

Node	S P R I N G S					
	TX [Lb/in]	TY [Lb/in]	TZ [Lb/in]	RX [Lb*in/Deg]	RY [Lb*in/Deg]	RZ [Lb*in/Deg]
1	0	53400	0	0	0	0
2	0	90000	0	0	0	0
3	0	90000	0	0	0	0
4	0	90000	0	0	0	0
5	0	53400	0	0	0	0
6	0	47400	0	0	0	0
7	0	84000	0	0	0	0
8	0	84000	0	0	0	0
9	0	84000	0	0	0	0
10	0	47400	0	0	0	0

11	0	73200	0	0	0	0
12	0	87600	0	0	0	0
13	0	85800	0	0	0	0
14	0	85200	0	0	0	0
15	0	87600	0	0	0	0
16	0	73200	0	0	0	0
17	0	109800	0	0	0	0
18	0	124200	0	0	0	0
19	0	122400	0	0	0	0
20	0	121800	0	0	0	0
21	0	124200	0	0	0	0
22	0	109800	0	0	0	0
23	0	109800	0	0	0	0
24	0	124200	0	0	0	0
25	0	122400	0	0	0	0
26	0	121800	0	0	0	0
27	0	124200	0	0	0	0
28	0	109800	0	0	0	0
29	0	109800	0	0	0	0
30	0	124200	0	0	0	0
31	0	122400	0	0	0	0
32	0	121800	0	0	0	0
33	0	124200	0	0	0	0
34	0	109800	0	0	0	0
35	0	73200	0	0	0	0
36	0	87600	0	0	0	0
37	0	85800	0	0	0	0
38	0	85200	0	0	0	0
39	0	87600	0	0	0	0
40	0	73200	0	0	0	0
41	0	64800	0	0	0	0
42	0	101400	0	0	0	0
43	0	101400	0	0	0	0
44	0	101400	0	0	0	0
45	0	64800	0	0	0	0

M E M B E R S						
Beam	NJ	NK	Description	Section	Material	
1	1	41	MainBeam	TUBE 8x8x1_4	A500 Gr B	
2	2	42	MainBeam	TUBE 8x8x1_4	A500 Gr B	
3	3	43	MainBeam	TUBE 8x8x1_4	A500 Gr B	
4	4	44	MainBeam	TUBE 8x8x1_4	A500 Gr B	
5	5	45	MainBeam	TUBE 8x8x1_4	A500 Gr B	
6	41	42	CrossBeam	TUBE 8x8x1_4	A500 Gr B	
7	42	43	CrossBeam	TUBE 8x8x1_4	A500 Gr B	
8	43	44	CrossBeam	TUBE 8x8x1_4	A500 Gr B	
9	44	45	CrossBeam	TUBE 8x8x1_4	A500 Gr B	
10	6	7	EndBeam	TUBE 8x8x1_4	A500 Gr B	
11	7	8	EndBeam	TUBE 8x8x1_4	A500 Gr B	
12	8	9	EndBeam	TUBE 8x8x1_4	A500 Gr B	
13	9	10	EndBeam	TUBE 8x8x1_4	A500 Gr B	
14	11	12	MainBeam	TUBE 8x8x1_4	A500 Gr B	
15	12	13	MainBeam	TUBE 8x8x1_4	A500 Gr B	
16	13	14	MainBeam	TUBE 8x8x1_4	A500 Gr B	
17	14	15	MainBeam	TUBE 8x8x1_4	A500 Gr B	
18	15	16	MainBeam	TUBE 8x8x1_4	A500 Gr B	
19	16	6	MainBeam	TUBE 8x8x1_4	A500 Gr B	
20	17	18	MainBeam	TUBE 8x8x1_4	A500 Gr B	
21	18	19	MainBeam	TUBE 8x8x1_4	A500 Gr B	
22	19	20	MainBeam	TUBE 8x8x1_4	A500 Gr B	
23	20	21	MainBeam	TUBE 8x8x1_4	A500 Gr B	
24	21	22	MainBeam	TUBE 8x8x1_4	A500 Gr B	
25	22	7	MainBeam	TUBE 8x8x1_4	A500 Gr B	
26	23	24	MainBeam	TUBE 8x8x1_4	A500 Gr B	
27	24	25	MainBeam	TUBE 8x8x1_4	A500 Gr B	
28	25	26	MainBeam	TUBE 8x8x1_4	A500 Gr B	
29	26	27	MainBeam	TUBE 8x8x1_4	A500 Gr B	
30	27	28	MainBeam	TUBE 8x8x1_4	A500 Gr B	
31	28	8	MainBeam	TUBE 8x8x1_4	A500 Gr B	

32	29	30	MainBeam	TUBE 8x8x1_4	A500 Gr B
33	30	31	MainBeam	TUBE 8x8x1_4	A500 Gr B
34	31	32	MainBeam	TUBE 8x8x1_4	A500 Gr B
35	32	33	MainBeam	TUBE 8x8x1_4	A500 Gr B
36	33	34	MainBeam	TUBE 8x8x1_4	A500 Gr B
37	34	9	MainBeam	TUBE 8x8x1_4	A500 Gr B
38	35	36	MainBeam	TUBE 8x8x1_4	A500 Gr B
39	36	37	MainBeam	TUBE 8x8x1_4	A500 Gr B
40	37	38	MainBeam	TUBE 8x8x1_4	A500 Gr B
41	38	39	MainBeam	TUBE 8x8x1_4	A500 Gr B
42	39	40	MainBeam	TUBE 8x8x1_4	A500 Gr B
43	40	10	MainBeam	TUBE 8x8x1_4	A500 Gr B
44	11	17	CrossBeam	TUBE 8x8x1_4	A500 Gr B
45	17	23	CrossBeam	TUBE 8x8x1_4	A500 Gr B
46	23	29	CrossBeam	TUBE 8x8x1_4	A500 Gr B
47	29	35	CrossBeam	TUBE 8x8x1_4	A500 Gr B
48	12	18	CrossBeam	TUBE 8x8x1_4	A500 Gr B
49	18	24	CrossBeam	TUBE 8x8x1_4	A500 Gr B
50	24	30	CrossBeam	TUBE 8x8x1_4	A500 Gr B
51	30	36	CrossBeam	TUBE 8x8x1_4	A500 Gr B
52	13	19	CrossBeam	TUBE 8x8x1_4	A500 Gr B
53	19	25	CrossBeam	TUBE 8x8x1_4	A500 Gr B
54	25	31	CrossBeam	TUBE 8x8x1_4	A500 Gr B
55	31	37	CrossBeam	TUBE 8x8x1_4	A500 Gr B
56	14	20	CrossBeam	TUBE 8x8x1_4	A500 Gr B
57	20	26	CrossBeam	TUBE 8x8x1_4	A500 Gr B
58	26	32	CrossBeam	TUBE 8x8x1_4	A500 Gr B
59	32	38	CrossBeam	TUBE 8x8x1_4	A500 Gr B
60	15	21	CrossBeam	TUBE 8x8x1_4	A500 Gr B
61	21	27	CrossBeam	TUBE 8x8x1_4	A500 Gr B
62	27	33	CrossBeam	TUBE 8x8x1_4	A500 Gr B
63	33	39	CrossBeam	TUBE 8x8x1_4	A500 Gr B
64	16	22	CrossBeam	TUBE 8x8x1_4	A500 Gr B
65	22	28	CrossBeam	TUBE 8x8x1_4	A500 Gr B
66	28	34	CrossBeam	TUBE 8x8x1_4	A500 Gr B
67	34	40	CrossBeam	TUBE 8x8x1_4	A500 Gr B
68	41	11	MainBeam	TUBE 8x8x1_4	A500 Gr B
69	42	17	MainBeam	TUBE 8x8x1_4	A500 Gr B
70	43	23	MainBeam	TUBE 8x8x1_4	A500 Gr B
71	44	29	MainBeam	TUBE 8x8x1_4	A500 Gr B
72	45	35	MainBeam	TUBE 8x8x1_4	A500 Gr B
73	1	2	EndBeam	TUBE 8x8x1_4	A500 Gr B
74	2	3	EndBeam	TUBE 8x8x1_4	A500 Gr B
75	3	4	EndBeam	TUBE 8x8x1_4	A500 Gr B
76	4	5	EndBeam	TUBE 8x8x1_4	A500 Gr B

Shell	S H E L L S				Description	Material	Thickness [in]
	N1	N2	N3	N4			
1	41	42	11	17	Pan	A36	0.188
2	42	43	17	23	Pan	A36	0.188
3	43	44	23	29	Pan	A36	0.188
4	44	45	29	35	Pan	A36	0.188
5	11	17	12	18	Pan	A36	0.188
6	17	23	18	24	Pan	A36	0.188
7	23	29	24	30	Pan	A36	0.188
8	29	35	30	36	Pan	A36	0.188
9	12	18	13	19	Pan	A36	0.188
10	18	24	19	25	Pan	A36	0.188
11	24	30	25	31	Pan	A36	0.188
12	30	36	31	37	Pan	A36	0.188
13	13	19	14	20	Pan	A36	0.188
14	19	25	20	26	Pan	A36	0.188
15	25	31	26	32	Pan	A36	0.188
16	31	37	32	38	Pan	A36	0.188
17	14	20	15	21	Pan	A36	0.188
18	20	26	21	27	Pan	A36	0.188
19	26	32	27	33	Pan	A36	0.188
20	32	38	33	39	Pan	A36	0.188
21	15	21	16	22	Pan	A36	0.188
22	21	27	22	28	Pan	A36	0.188

23	27	33	28	34	Pan	A36	0.188
24	33	39	34	40	Pan	A36	0.188
25	16	22	6	7	Pan	A36	0.188
26	22	28	7	8	Pan	A36	0.188
27	28	34	8	9	Pan	A36	0.188
28	34	40	9	10	Pan	A36	0.188

L O A D D A T A

File : C:\Current Projects\V-Tank Analysis\Skid Design\TnkSkid4.AVW
Units : Lb-ft
Date : 7/13/2004
Time : 1:15:40 PM

ConditioNode		NODAL FORCES					
		FX	FY	FZ	MX	MY	MZ
		[Lb]	[Lb]	[Lb]	[Lb*ft]	[Lb*ft]	[Lb*ft]
SP	8	0	-5500	0	0	0	0
LC1	8	0	-5500	0	0	0	0
LC2	8	0	-5500	0	0	0	0
LC3	8	0	-5500	0	0	0	0
LC4	8	0	-5500	0	0	0	0

ConditioBeam		CONCENTRATED FORCES ON MEMBERS			
		Dir.	Value	Distance	%
			[Lb]	[ft]	
TK	44	Y	-20000	1.5	0
	45	Y	-20000	3.58333	0
	46	Y	-20000	1.5	0
	47	Y	-20000	3.58333	0
	52	Y	-20000	1.5	0
	53	Y	-20000	3.58333	0
	54	Y	-20000	1.5	0
	55	Y	-20000	3.58333	0
	58	Y	-20000	1.5	0
	59	Y	-20000	3.58333	0
	66	Y	-20000	1.5	0
	67	Y	-20000	3.58333	0
TK1	44	Y	-3000	1.5	0
	45	Y	-3000	3.58333	0
	46	Y	-20000	1.5	0
	47	Y	-20000	3.58333	0
	52	Y	-3000	1.5	0
	53	Y	-3000	3.58333	0
	54	Y	-20000	1.5	0
	55	Y	-20000	3.58333	0
	58	Y	-20000	1.5	0
	59	Y	-20000	3.58333	0
	66	Y	-20000	1.5	0
	67	Y	-20000	3.58333	0
TK2	44	Y	-20000	1.5	0
	45	Y	-20000	3.58333	0
	46	Y	-3000	1.5	0
	47	Y	-3000	3.58333	0
	52	Y	-20000	1.5	0
	53	Y	-20000	3.58333	0
	54	Y	-3000	1.5	0
	55	Y	-3000	3.58333	0
	58	Y	-20000	1.5	0
	59	Y	-20000	3.58333	0
	66	Y	-20000	1.5	0
	67	Y	-20000	3.58333	0
TK3	44	Y	-20000	1.5	0
	45	Y	-20000	3.58333	0
	46	Y	-20000	1.5	0
	47	Y	-20000	3.58333	0
	52	Y	-20000	1.5	0

	53	Y	-20000	3.58333	0
	54	Y	-20000	1.5	0
	55	Y	-20000	3.58333	0
	58	Y	-3000	1.5	0
	59	Y	-3000	3.58333	0
	66	Y	-3000	1.5	0
	67	Y	-3000	3.58333	0
SP	16	Y	-5500	2	0
	28	Y	-5500	2	0

Condition	Shell	LOADS ON SHELLS	
		Pressure [Lb/ft2]	Temp. [F]
SC	1	187	0
	2	187	0
	3	187	0
	4	187	0
	5	187	0
	6	187	0
	7	187	0
	8	187	0
	9	187	0
	10	187	0
	11	187	0
	12	187	0
	13	187	0
	14	187	0
	15	187	0
	16	187	0
	17	187	0
	18	187	0
	19	187	0
	20	187	0
	21	187	0
	22	187	0
	23	187	0
	24	187	0
	25	187	0
	26	187	0
	27	187	0
	28	187	0
LC2	1	187	0
	2	187	0
	3	187	0
	4	187	0
	5	187	0
	6	187	0
	7	187	0
	8	187	0
	9	187	0
	10	187	0
	11	187	0
	12	187	0
	13	187	0
	14	187	0
	15	187	0
	16	187	0
	17	187	0
	18	187	0
	19	187	0
	20	187	0
	21	187	0
	22	187	0
	23	187	0
	24	187	0
	25	187	0
	26	187	0
	27	187	0
	28	187	0
LC3	1	187	0
	2	187	0

	3	187	0
	4	187	0
	5	187	0
	6	187	0
	7	187	0
	8	187	0
	9	187	0
	10	187	0
	11	187	0
	12	187	0
	13	187	0
	14	187	0
	15	187	0
	16	187	0
	17	187	0
	18	187	0
	19	187	0
	20	187	0
	21	187	0
	22	187	0
	23	187	0
	24	187	0
	25	187	0
	26	187	0
	27	187	0
	28	187	0
LC4	1	187	0
	2	187	0
	3	187	0
	4	187	0
	5	187	0
	6	187	0
	7	187	0
	8	187	0
	9	187	0
	10	187	0
	11	187	0
	12	187	0
	13	187	0
	14	187	0
	15	187	0
	16	187	0
	17	187	0
	18	187	0
	19	187	0
	20	187	0
	21	187	0
	22	187	0
	23	187	0
	24	187	0
	25	187	0
	26	187	0
	27	187	0
	28	187	0

LOAD CONDITIONS

--Self weight multiplier--

Conditio	Description	Comb.	Multx	Multy	Multz
DL	Dead load	0	0	-1	0
TK	All Tanks Full	0	0	0	0
SC	Containment	0	0	0	0
TK1	Tank 1 Empty	0	0	0	0
TK2	Tank 2 Empty	0	0	0	0
TK3	Tank 3 Empty	0	0	0	0
SP	Shield Panel Wt	0	0	0	0
LC1	DL+TK+SP	1	0	0	0
LC2	DL+SC+TK1+SP	1	0	0	0
LC3	DL+SC+TK2+SP	1	0	0	0
LC4	DL+SC+TK3+SP	1	0	0	0

A N A L Y S I S R E S U L T S

File : C:\Current Projects\V-Tank Analysis\Skid Design\TnkSkid4.AVW
 Units : Kip-in
 Date : 7/13/2004
 Time : 1:16:58 PM

Node	FORCES [Kip]		R E A C T I O N S			
	FX	FY	FZ	MOMENTS MX	MY	MZ

Condition LC1=DL+TK+SP						
1	0.00000	0.55341	0.00000	0.00000	0.00000	0.00000
2	0.00000	1.14151	0.00000	0.00000	0.00000	0.00000
3	0.00000	1.36870	0.00000	0.00000	0.00000	0.00000
4	0.00000	1.09778	0.00000	0.00000	0.00000	0.00000
5	0.00000	0.49292	0.00000	0.00000	0.00000	0.00000
6	0.00000	-0.55904	0.00000	0.00000	0.00000	0.00000
7	0.00000	0.93128	0.00000	0.00000	0.00000	0.00000
8	0.00000	5.20439	0.00000	0.00000	0.00000	0.00000
9	0.00000	5.72513	0.00000	0.00000	0.00000	0.00000
10	0.00000	3.20531	0.00000	0.00000	0.00000	0.00000
11	0.00000	4.75031	0.00000	0.00000	0.00000	0.00000
12	0.00000	6.30578	0.00000	0.00000	0.00000	0.00000
13	0.00000	7.42451	0.00000	0.00000	0.00000	0.00000
14	0.00000	4.54571	0.00000	0.00000	0.00000	0.00000
15	0.00000	0.86731	0.00000	0.00000	0.00000	0.00000
16	0.00000	-0.59409	0.00000	0.00000	0.00000	0.00000
17	0.00000	7.39998	0.00000	0.00000	0.00000	0.00000
18	0.00000	9.23202	0.00000	0.00000	0.00000	0.00000
19	0.00000	10.27725	0.00000	0.00000	0.00000	0.00000
20	0.00000	6.30141	0.00000	0.00000	0.00000	0.00000
21	0.00000	2.36286	0.00000	0.00000	0.00000	0.00000
22	0.00000	1.18111	0.00000	0.00000	0.00000	0.00000
23	0.00000	10.01785	0.00000	0.00000	0.00000	0.00000
24	0.00000	11.76536	0.00000	0.00000	0.00000	0.00000
25	0.00000	16.77575	0.00000	0.00000	0.00000	0.00000
26	0.00000	13.49625	0.00000	0.00000	0.00000	0.00000
27	0.00000	6.95688	0.00000	0.00000	0.00000	0.00000
28	0.00000	6.81245	0.00000	0.00000	0.00000	0.00000
29	0.00000	7.29166	0.00000	0.00000	0.00000	0.00000
30	0.00000	9.68951	0.00000	0.00000	0.00000	0.00000
31	0.00000	13.36164	0.00000	0.00000	0.00000	0.00000
32	0.00000	12.88782	0.00000	0.00000	0.00000	0.00000
33	0.00000	8.75213	0.00000	0.00000	0.00000	0.00000
34	0.00000	7.95828	0.00000	0.00000	0.00000	0.00000
35	0.00000	4.55296	0.00000	0.00000	0.00000	0.00000
36	0.00000	6.28797	0.00000	0.00000	0.00000	0.00000
37	0.00000	8.89281	0.00000	0.00000	0.00000	0.00000
38	0.00000	8.79014	0.00000	0.00000	0.00000	0.00000
39	0.00000	6.33121	0.00000	0.00000	0.00000	0.00000
40	0.00000	5.46125	0.00000	0.00000	0.00000	0.00000
41	0.00000	2.98220	0.00000	0.00000	0.00000	0.00000
42	0.00000	4.98392	0.00000	0.00000	0.00000	0.00000
43	0.00000	6.47515	0.00000	0.00000	0.00000	0.00000
44	0.00000	4.88748	0.00000	0.00000	0.00000	0.00000
45	0.00000	2.84149	0.00000	0.00000	0.00000	0.00000

SUM	0.00000	267.46772	0.00000	0.00000	0.00000	0.00000

Condition LC2=DL+SC+TK1+SP						
1	0.00000	-0.09121	0.00000	0.00000	0.00000	0.00000
2	0.00000	0.24519	0.00000	0.00000	0.00000	0.00000
3	0.00000	0.94797	0.00000	0.00000	0.00000	0.00000
4	0.00000	1.33037	0.00000	0.00000	0.00000	0.00000
5	0.00000	0.75577	0.00000	0.00000	0.00000	0.00000
6	0.00000	0.16562	0.00000	0.00000	0.00000	0.00000
7	0.00000	2.29163	0.00000	0.00000	0.00000	0.00000
8	0.00000	6.53037	0.00000	0.00000	0.00000	0.00000
9	0.00000	6.90789	0.00000	0.00000	0.00000	0.00000
10	0.00000	3.72833	0.00000	0.00000	0.00000	0.00000
11	0.00000	1.59267	0.00000	0.00000	0.00000	0.00000

12	0.00000	2.95092	0.00000	0.00000	0.00000	0.00000
13	0.00000	4.04118	0.00000	0.00000	0.00000	0.00000
14	0.00000	3.76728	0.00000	0.00000	0.00000	0.00000
15	0.00000	2.17490	0.00000	0.00000	0.00000	0.00000
16	0.00000	0.68660	0.00000	0.00000	0.00000	0.00000
17	0.00000	3.67526	0.00000	0.00000	0.00000	0.00000
18	0.00000	5.86328	0.00000	0.00000	0.00000	0.00000
19	0.00000	6.77322	0.00000	0.00000	0.00000	0.00000
20	0.00000	6.18226	0.00000	0.00000	0.00000	0.00000
21	0.00000	4.93014	0.00000	0.00000	0.00000	0.00000
22	0.00000	3.37431	0.00000	0.00000	0.00000	0.00000
23	0.00000	7.73578	0.00000	0.00000	0.00000	0.00000
24	0.00000	10.45186	0.00000	0.00000	0.00000	0.00000
25	0.00000	14.96471	0.00000	0.00000	0.00000	0.00000
26	0.00000	14.55758	0.00000	0.00000	0.00000	0.00000
27	0.00000	9.96674	0.00000	0.00000	0.00000	0.00000
28	0.00000	9.04873	0.00000	0.00000	0.00000	0.00000
29	0.00000	8.54505	0.00000	0.00000	0.00000	0.00000
30	0.00000	11.97250	0.00000	0.00000	0.00000	0.00000
31	0.00000	16.01768	0.00000	0.00000	0.00000	0.00000
32	0.00000	15.81315	0.00000	0.00000	0.00000	0.00000
33	0.00000	11.85519	0.00000	0.00000	0.00000	0.00000
34	0.00000	10.00002	0.00000	0.00000	0.00000	0.00000
35	0.00000	5.73198	0.00000	0.00000	0.00000	0.00000
36	0.00000	8.25216	0.00000	0.00000	0.00000	0.00000
37	0.00000	10.93554	0.00000	0.00000	0.00000	0.00000
38	0.00000	10.75158	0.00000	0.00000	0.00000	0.00000
39	0.00000	8.12623	0.00000	0.00000	0.00000	0.00000
40	0.00000	6.53013	0.00000	0.00000	0.00000	0.00000
41	0.00000	0.85884	0.00000	0.00000	0.00000	0.00000
42	0.00000	2.30346	0.00000	0.00000	0.00000	0.00000
43	0.00000	4.91767	0.00000	0.00000	0.00000	0.00000
44	0.00000	5.64301	0.00000	0.00000	0.00000	0.00000
45	0.00000	3.61204	0.00000	0.00000	0.00000	0.00000

SUM	0.00000	277.41555	0.00000	0.00000	0.00000	0.00000
-----	---------	-----------	---------	---------	---------	---------

Condition LC3=DL+SC+TK2+SP

1	0.00000	0.81626	0.00000	0.00000	0.00000	0.00000
2	0.00000	1.37410	0.00000	0.00000	0.00000	0.00000
3	0.00000	0.94797	0.00000	0.00000	0.00000	0.00000
4	0.00000	0.20146	0.00000	0.00000	0.00000	0.00000
5	0.00000	-0.15170	0.00000	0.00000	0.00000	0.00000
6	0.00000	-0.03602	0.00000	0.00000	0.00000	0.00000
7	0.00000	2.11404	0.00000	0.00000	0.00000	0.00000
8	0.00000	6.53037	0.00000	0.00000	0.00000	0.00000
9	0.00000	7.08548	0.00000	0.00000	0.00000	0.00000
10	0.00000	3.92997	0.00000	0.00000	0.00000	0.00000
11	0.00000	5.92933	0.00000	0.00000	0.00000	0.00000
12	0.00000	8.26997	0.00000	0.00000	0.00000	0.00000
13	0.00000	9.46725	0.00000	0.00000	0.00000	0.00000
14	0.00000	6.50714	0.00000	0.00000	0.00000	0.00000
15	0.00000	2.66234	0.00000	0.00000	0.00000	0.00000
16	0.00000	0.47479	0.00000	0.00000	0.00000	0.00000
17	0.00000	8.65337	0.00000	0.00000	0.00000	0.00000
18	0.00000	11.51501	0.00000	0.00000	0.00000	0.00000
19	0.00000	12.93328	0.00000	0.00000	0.00000	0.00000
20	0.00000	9.22673	0.00000	0.00000	0.00000	0.00000
21	0.00000	5.46592	0.00000	0.00000	0.00000	0.00000
22	0.00000	3.22285	0.00000	0.00000	0.00000	0.00000
23	0.00000	7.73578	0.00000	0.00000	0.00000	0.00000
24	0.00000	10.45186	0.00000	0.00000	0.00000	0.00000
25	0.00000	14.96471	0.00000	0.00000	0.00000	0.00000
26	0.00000	14.55758	0.00000	0.00000	0.00000	0.00000
27	0.00000	9.96674	0.00000	0.00000	0.00000	0.00000
28	0.00000	9.04873	0.00000	0.00000	0.00000	0.00000
29	0.00000	3.56693	0.00000	0.00000	0.00000	0.00000
30	0.00000	6.32077	0.00000	0.00000	0.00000	0.00000
31	0.00000	9.85762	0.00000	0.00000	0.00000	0.00000
32	0.00000	12.76868	0.00000	0.00000	0.00000	0.00000
33	0.00000	11.31941	0.00000	0.00000	0.00000	0.00000
34	0.00000	10.15148	0.00000	0.00000	0.00000	0.00000
35	0.00000	1.39532	0.00000	0.00000	0.00000	0.00000

36	0.00000	2.93311	0.00000	0.00000	0.00000	0.00000
37	0.00000	5.50947	0.00000	0.00000	0.00000	0.00000
38	0.00000	8.01171	0.00000	0.00000	0.00000	0.00000
39	0.00000	7.63880	0.00000	0.00000	0.00000	0.00000
40	0.00000	6.74194	0.00000	0.00000	0.00000	0.00000
41	0.00000	3.75275	0.00000	0.00000	0.00000	0.00000
42	0.00000	5.73944	0.00000	0.00000	0.00000	0.00000
43	0.00000	4.91767	0.00000	0.00000	0.00000	0.00000
44	0.00000	2.20702	0.00000	0.00000	0.00000	0.00000
45	0.00000	0.71813	0.00000	0.00000	0.00000	0.00000

SUM	0.00000	277.41555	0.00000	0.00000	0.00000	0.00000

Condition LC4=DL+SC+TK3+SP

1	0.00000	0.56828	0.00000	0.00000	0.00000	0.00000
2	0.00000	1.25863	0.00000	0.00000	0.00000	0.00000
3	0.00000	1.53323	0.00000	0.00000	0.00000	0.00000
4	0.00000	1.29190	0.00000	0.00000	0.00000	0.00000
5	0.00000	0.60962	0.00000	0.00000	0.00000	0.00000
6	0.00000	0.23346	0.00000	0.00000	0.00000	0.00000
7	0.00000	1.67530	0.00000	0.00000	0.00000	0.00000
8	0.00000	3.39260	0.00000	0.00000	0.00000	0.00000
9	0.00000	2.46490	0.00000	0.00000	0.00000	0.00000
10	0.00000	0.85957	0.00000	0.00000	0.00000	0.00000
11	0.00000	5.73157	0.00000	0.00000	0.00000	0.00000
12	0.00000	8.10851	0.00000	0.00000	0.00000	0.00000
13	0.00000	9.40554	0.00000	0.00000	0.00000	0.00000
14	0.00000	6.57450	0.00000	0.00000	0.00000	0.00000
15	0.00000	2.88935	0.00000	0.00000	0.00000	0.00000
16	0.00000	0.81480	0.00000	0.00000	0.00000	0.00000
17	0.00000	9.29327	0.00000	0.00000	0.00000	0.00000
18	0.00000	12.35026	0.00000	0.00000	0.00000	0.00000
19	0.00000	13.23909	0.00000	0.00000	0.00000	0.00000
20	0.00000	8.96922	0.00000	0.00000	0.00000	0.00000
21	0.00000	4.71644	0.00000	0.00000	0.00000	0.00000
22	0.00000	2.56926	0.00000	0.00000	0.00000	0.00000
23	0.00000	12.08553	0.00000	0.00000	0.00000	0.00000
24	0.00000	14.80013	0.00000	0.00000	0.00000	0.00000
25	0.00000	17.88979	0.00000	0.00000	0.00000	0.00000
26	0.00000	11.76837	0.00000	0.00000	0.00000	0.00000
27	0.00000	5.72681	0.00000	0.00000	0.00000	0.00000
28	0.00000	4.24920	0.00000	0.00000	0.00000	0.00000
29	0.00000	9.28856	0.00000	0.00000	0.00000	0.00000
30	0.00000	12.29208	0.00000	0.00000	0.00000	0.00000
31	0.00000	13.32225	0.00000	0.00000	0.00000	0.00000
32	0.00000	9.52997	0.00000	0.00000	0.00000	0.00000
33	0.00000	5.47662	0.00000	0.00000	0.00000	0.00000
34	0.00000	3.60530	0.00000	0.00000	0.00000	0.00000
35	0.00000	5.67194	0.00000	0.00000	0.00000	0.00000
36	0.00000	7.62588	0.00000	0.00000	0.00000	0.00000
37	0.00000	8.19550	0.00000	0.00000	0.00000	0.00000
38	0.00000	5.55632	0.00000	0.00000	0.00000	0.00000
39	0.00000	3.01851	0.00000	0.00000	0.00000	0.00000
40	0.00000	1.68005	0.00000	0.00000	0.00000	0.00000
41	0.00000	3.53761	0.00000	0.00000	0.00000	0.00000
42	0.00000	6.12491	0.00000	0.00000	0.00000	0.00000
43	0.00000	7.74248	0.00000	0.00000	0.00000	0.00000
44	0.00000	6.13959	0.00000	0.00000	0.00000	0.00000
45	0.00000	3.53885	0.00000	0.00000	0.00000	0.00000

SUM	0.00000	277.41555	0.00000	0.00000	0.00000	0.00000

MEMBER FORCES AT SIGNIFICANT POINTS

Condit.: LC1=DL+TK+SP

Station	Dist to J [in]	Axial [Kip]	Plane 1-2		Plane 1-3		Torsion [Kip*in]
			Shear V2 [Kip]	M33 [Kip*in]	Shear V3 [Kip]	M22 [Kip*in]	
MEMBER 1							
0%	0.000	0.000	-0.714	1.209	0.000	0.000	-7.752
100%	28.000	0.000	-0.653	20.345	0.000	0.000	-7.752
MEMBER 2							
0%	0.000	0.000	-0.667	6.027	0.000	0.000	-4.026
100%	28.000	0.000	-0.606	23.847	0.000	0.000	-4.026
MEMBER 3							
0%	0.000	0.000	-1.459	-14.870	0.000	0.000	0.099
100%	28.000	0.000	-1.398	25.118	0.000	0.000	0.099
MEMBER 4							
0%	0.000	0.000	-0.617	6.039	0.000	0.000	4.342
100%	28.000	0.000	-0.556	22.468	0.000	0.000	4.342
MEMBER 5							
0%	0.000	0.000	-0.664	1.595	0.000	0.000	8.295
100%	28.000	0.000	-0.603	19.341	0.000	0.000	8.295
MEMBER 6							
0%	0.000	0.000	0.911	33.593	0.000	0.000	0.107
100%	61.000	0.000	1.044	-26.019	0.000	0.000	0.107
MEMBER 7							
0%	0.000	0.000	-1.218	-30.443	0.000	0.000	9.834
100%	61.000	0.000	-1.085	39.799	0.000	0.000	9.834
MEMBER 8							
0%	0.000	0.000	1.094	40.214	0.000	0.000	-10.051
100%	61.000	0.000	1.227	-30.568	0.000	0.000	-10.051
MEMBER 9							
0%	0.000	0.000	-1.054	-25.932	0.000	0.000	-0.593
100%	61.000	0.000	-0.921	34.290	0.000	0.000	-0.593
MEMBER 10							
0%	0.000	0.000	0.380	-2.926	0.000	0.000	4.103
100%	61.000	0.000	0.514	-30.199	0.000	0.000	4.103
MEMBER 11							
0%	0.000	0.000	-1.284	-37.158	0.000	0.000	-1.046
100%	61.000	0.000	-1.151	37.124	0.000	0.000	-1.046
MEMBER 12							
0%	0.000	0.000	1.410	67.580	0.000	0.000	-4.761
100%	61.000	0.000	1.543	-22.494	0.000	0.000	-4.761
MEMBER 13							
0%	0.000	0.000	-0.992	-17.100	0.000	0.000	-3.197
100%	61.000	0.000	-0.859	39.357	0.000	0.000	-3.197
MEMBER 14							
0%	0.000	0.000	3.603	101.386	0.000	0.000	18.697
100%	43.000	0.000	3.697	-55.561	0.000	0.000	18.697
MEMBER 15							
0%	0.000	0.000	-3.629	-56.422	0.000	0.000	-15.874
100%	43.000	0.000	-3.535	97.610	0.000	0.000	-15.874
MEMBER 16							
0%	0.000	0.000	0.934	95.512	0.000	0.000	26.267
100%	38.000	0.000	6.517	-18.562	0.000	0.000	26.267
MEMBER 17							
0%	0.000	0.000	0.580	-14.318	0.000	0.000	-2.220
100%	43.000	0.000	0.674	-41.296	0.000	0.000	-2.220
MEMBER 18							
0%	0.000	0.000	-0.606	-36.576	0.000	0.000	-4.329
100%	43.000	0.000	-0.512	-12.533	0.000	0.000	-4.329
MEMBER 19							
0%	0.000	0.000	-0.233	-7.932	0.000	0.000	-2.927
100%	18.000	0.000	-0.193	-4.101	0.000	0.000	-2.927
MEMBER 20							
0%	0.000	0.000	3.334	97.134	0.000	0.000	-2.452
100%	43.000	0.000	3.428	-48.249	0.000	0.000	-2.452
MEMBER 21							
0%	0.000	0.000	-3.081	-41.615	0.000	0.000	-4.199
100%	43.000	0.000	-2.987	88.854	0.000	0.000	-4.199
MEMBER 22							
0%	0.000	0.000	3.075	104.378	0.000	0.000	-2.899
100%	38.000	0.000	3.158	-14.066	0.000	0.000	-2.899

MEMBER 23							
0%	0.000	0.000	0.106	-25.680	0.000	0.000	0.512
100%	43.000	0.000	0.200	-32.250	0.000	0.000	0.512
MEMBER 24							
0%	0.000	0.000	-0.700	-38.298	0.000	0.000	-4.228
100%	43.000	0.000	-0.606	-10.231	0.000	0.000	-4.228
MEMBER 25							
0%	0.000	0.000	-0.932	-11.304	0.000	0.000	-6.923
100%	18.000	0.000	-0.893	5.127	0.000	0.000	-6.923
MEMBER 26							
0%	0.000	0.000	7.201	176.780	0.000	0.000	-1.962
100%	43.000	0.000	7.295	-134.886	0.000	0.000	-1.962
MEMBER 27							
0%	0.000	0.000	-6.826	-140.989	0.000	0.000	-7.979
100%	43.000	0.000	-6.732	150.491	0.000	0.000	-7.979
MEMBER 28							
0%	0.000	0.000	1.111	139.134	0.000	0.000	-24.872
100%	38.000	0.000	6.694	18.324	0.000	0.000	-24.872
MEMBER 29							
0%	0.000	0.000	3.866	40.369	0.000	0.000	13.874
100%	43.000	0.000	3.960	-127.887	0.000	0.000	13.874
MEMBER 30							
0%	0.000	0.000	-4.117	-123.665	0.000	0.000	-14.054
100%	43.000	0.000	-4.023	51.342	0.000	0.000	-14.054
MEMBER 31							
0%	0.000	0.000	2.197	43.601	0.000	0.000	30.387
100%	18.000	0.000	2.236	3.710	0.000	0.000	30.387
MEMBER 32							
0%	0.000	0.000	3.663	91.551	0.000	0.000	1.548
100%	43.000	0.000	3.757	-67.969	0.000	0.000	1.548
MEMBER 33							
0%	0.000	0.000	-3.162	-68.177	0.000	0.000	-0.140
100%	43.000	0.000	-3.068	65.768	0.000	0.000	-0.140
MEMBER 34							
0%	0.000	0.000	-0.215	64.667	0.000	0.000	-4.324
100%	38.000	0.000	-0.132	71.274	0.000	0.000	-4.324
MEMBER 35							
0%	0.000	0.000	3.393	59.245	0.000	0.000	-5.385
100%	43.000	0.000	3.487	-88.673	0.000	0.000	-5.385
MEMBER 36							
0%	0.000	0.000	-3.368	-90.016	0.000	0.000	0.647
100%	43.000	0.000	-3.274	52.798	0.000	0.000	0.647
MEMBER 37							
0%	0.000	0.000	3.113	54.884	0.000	0.000	5.369
100%	18.000	0.000	3.152	-1.505	0.000	0.000	5.369
MEMBER 38							
0%	0.000	0.000	3.962	98.277	0.000	0.000	-15.918
100%	43.000	0.000	4.056	-74.110	0.000	0.000	-15.918
MEMBER 39							
0%	0.000	0.000	-3.240	-73.572	0.000	0.000	23.758
100%	43.000	0.000	-3.146	63.734	0.000	0.000	23.758
MEMBER 40							
0%	0.000	0.000	-0.065	62.771	0.000	0.000	-0.380
80%	30.400	0.000	0.001	63.740	0.000	0.000	-0.380
100%	38.000	0.000	0.018	63.667	0.000	0.000	-0.380
MEMBER 41							
0%	0.000	0.000	3.345	60.981	0.000	0.000	-24.615
100%	43.000	0.000	3.438	-84.853	0.000	0.000	-24.615
MEMBER 42							
0%	0.000	0.000	-3.619	-86.404	0.000	0.000	16.431
100%	43.000	0.000	-3.525	67.203	0.000	0.000	16.431
MEMBER 43							
0%	0.000	0.000	4.005	69.287	0.000	0.000	-39.299
100%	18.000	0.000	4.045	-3.161	0.000	0.000	-39.299
MEMBER 44							
0%	0.000	0.000	-12.798	-60.091	0.000	0.000	-0.236
30%	18.300	0.000	7.242	167.745	0.000	0.000	-0.236
100%	61.000	0.000	7.335	-143.479	0.000	0.000	-0.236
MEMBER 45							
0%	0.000	0.000	-6.561	-140.628	0.000	0.000	4.361
70%	42.700	0.000	-6.467	137.523	0.000	0.000	4.361
100%	61.000	0.000	13.573	-104.488	0.000	0.000	4.361

MEMBER 46							
0%	0.000	0.000	-13.536	-102.843	0.000	0.000	-4.046
30%	18.300	0.000	6.504	138.494	0.000	0.000	-4.046
100%	61.000	0.000	6.598	-141.229	0.000	0.000	-4.046
MEMBER 47							
0%	0.000	0.000	-7.354	-143.073	0.000	0.000	-0.418
70%	42.700	0.000	-7.261	168.945	0.000	0.000	-0.418
100%	61.000	0.000	12.779	-58.552	0.000	0.000	-0.418
MEMBER 48							
0%	0.000	0.000	1.092	34.578	0.000	0.000	-0.858
100%	61.000	0.000	1.225	-36.073	0.000	0.000	-0.858
MEMBER 49							
0%	0.000	0.000	-1.354	-34.329	0.000	0.000	5.782
100%	61.000	0.000	-1.220	44.182	0.000	0.000	5.782
MEMBER 50							
0%	0.000	0.000	1.280	50.199	0.000	0.000	-0.323
100%	61.000	0.000	1.413	-31.923	0.000	0.000	-0.323
MEMBER 51							
0%	0.000	0.000	-1.213	-30.234	0.000	0.000	-0.537
100%	61.000	0.000	-1.080	39.686	0.000	0.000	-0.537
MEMBER 52							
0%	0.000	0.000	-11.832	-42.214	0.000	0.000	-2.088
30%	18.300	0.000	8.208	167.949	0.000	0.000	-2.088
100%	61.000	0.000	8.301	-184.514	0.000	0.000	-2.088
MEMBER 53							
0%	0.000	0.000	-7.910	-185.811	0.000	0.000	13.454
70%	42.700	0.000	-7.817	149.967	0.000	0.000	13.454
100%	61.000	0.000	12.223	-67.347	0.000	0.000	13.454
MEMBER 54							
0%	0.000	0.000	-12.273	-50.449	0.000	0.000	2.098
30%	18.300	0.000	7.767	167.774	0.000	0.000	2.098
100%	61.000	0.000	7.861	-165.883	0.000	0.000	2.098
MEMBER 55							
0%	0.000	0.000	-8.222	-161.703	0.000	0.000	0.973
70%	42.700	0.000	-8.129	187.402	0.000	0.000	0.973
100%	61.000	0.000	11.911	-24.201	0.000	0.000	0.973
MEMBER 56							
0%	0.000	0.000	1.457	28.491	0.000	0.000	4.248
100%	61.000	0.000	1.590	-64.451	0.000	0.000	4.248
MEMBER 57							
0%	0.000	0.000	-1.524	-67.864	0.000	0.000	-7.346
100%	61.000	0.000	-1.390	21.012	0.000	0.000	-7.346
MEMBER 58							
0%	0.000	0.000	-11.930	-17.800	0.000	0.000	14.700
30%	18.300	0.000	8.110	194.150	0.000	0.000	14.700
100%	61.000	0.000	8.203	-154.146	0.000	0.000	14.700
MEMBER 59							
0%	0.000	0.000	-8.079	-153.083	0.000	0.000	2.680
70%	42.700	0.000	-7.986	189.918	0.000	0.000	2.680
100%	61.000	0.000	12.054	-24.301	0.000	0.000	2.680
MEMBER 60							
0%	0.000	0.000	0.483	2.111	0.000	0.000	4.719
100%	61.000	0.000	0.616	-31.394	0.000	0.000	4.719
MEMBER 61							
0%	0.000	0.000	-0.708	-26.653	0.000	0.000	-1.331
100%	61.000	0.000	-0.575	12.463	0.000	0.000	-1.331
MEMBER 62							
0%	0.000	0.000	0.688	40.396	0.000	0.000	2.891
100%	61.000	0.000	0.821	-5.646	0.000	0.000	2.891
MEMBER 63							
0%	0.000	0.000	-0.931	-11.674	0.000	0.000	1.551
100%	61.000	0.000	-0.798	41.055	0.000	0.000	1.551
MEMBER 64							
0%	0.000	0.000	0.363	-1.404	0.000	0.000	4.601
100%	61.000	0.000	0.497	-27.632	0.000	0.000	4.601
MEMBER 65							
0%	0.000	0.000	-0.257	-24.903	0.000	0.000	3.506
100%	61.000	0.000	-0.124	-13.307	0.000	0.000	3.506
MEMBER 66							
0%	0.000	0.000	-13.061	-57.857	0.000	0.000	-4.245
30%	18.300	0.000	6.979	174.785	0.000	0.000	-4.245
100%	61.000	0.000	7.073	-125.228	0.000	0.000	-4.245

MEMBER 67							
0%	0.000	0.000	-7.184	-129.972	0.000	0.000	-2.112
70%	42.700	0.000	-7.090	174.777	0.000	0.000	-2.112
100%	61.000	0.000	12.950	-55.835	0.000	0.000	-2.112
MEMBER 68							
0%	0.000	0.000	-4.526	20.481	0.000	0.000	-41.289
100%	18.000	0.000	-4.487	101.597	0.000	0.000	-41.289
MEMBER 69							
0%	0.000	0.000	-3.291	33.609	0.000	0.000	0.369
100%	18.000	0.000	-3.252	92.501	0.000	0.000	0.369
MEMBER 70							
0%	0.000	0.000	-10.015	5.257	0.000	0.000	-0.316
100%	18.000	0.000	-9.975	185.164	0.000	0.000	-0.316
MEMBER 71							
0%	0.000	0.000	-3.126	31.963	0.000	0.000	-0.265
100%	18.000	0.000	-3.087	87.885	0.000	0.000	-0.265
MEMBER 72							
0%	0.000	0.000	-4.346	19.963	0.000	0.000	42.528
100%	18.000	0.000	-4.306	97.833	0.000	0.000	42.528
MEMBER 73							
0%	0.000	0.000	0.161	7.752	0.000	0.000	1.209
100%	61.000	0.000	0.294	-6.108	0.000	0.000	1.209
MEMBER 74							
0%	0.000	0.000	-0.181	-2.083	0.000	0.000	7.236
100%	61.000	0.000	-0.047	4.875	0.000	0.000	7.236
MEMBER 75							
0%	0.000	0.000	0.043	4.776	0.000	0.000	-7.634
100%	61.000	0.000	0.176	-1.885	0.000	0.000	-7.634
MEMBER 76							
0%	0.000	0.000	-0.305	-6.227	0.000	0.000	-1.595
100%	61.000	0.000	-0.171	8.295	0.000	0.000	-1.595

Condit.: LC2=DL+SC+TK1+SP

Station	Dist to J [in]	Axial [Kip]	Plane 1-2		Plane 1-3		Torsion [Kip*in]
			Shear V2 [Kip]	M33 [Kip*in]	Shear V3 [Kip]	M22 [Kip*in]	
MEMBER 1							
0%	0.000	0.000	-0.014	4.287	0.000	0.000	-2.790
25%	7.000	0.000	0.001	4.333	0.000	0.000	-2.790
100%	28.000	0.000	0.047	3.829	0.000	0.000	-2.790
MEMBER 2							
0%	0.000	0.000	0.011	7.974	0.000	0.000	-7.596
100%	28.000	0.000	0.072	6.811	0.000	0.000	-7.596
MEMBER 3							
0%	0.000	0.000	-0.917	-9.166	0.000	0.000	-11.128
100%	28.000	0.000	-0.856	15.645	0.000	0.000	-11.128
MEMBER 4							
0%	0.000	0.000	-0.908	-2.399	0.000	0.000	-1.344
100%	28.000	0.000	-0.847	22.170	0.000	0.000	-1.344
MEMBER 5							
0%	0.000	0.000	-0.827	-0.696	0.000	0.000	8.576
100%	28.000	0.000	-0.766	21.611	0.000	0.000	8.576
MEMBER 6							
0%	0.000	0.000	0.300	4.911	0.000	0.000	3.404
100%	61.000	0.000	0.434	-17.474	0.000	0.000	3.404
MEMBER 7							
0%	0.000	0.000	-0.629	-21.555	0.000	0.000	13.361
100%	61.000	0.000	-0.495	12.722	0.000	0.000	13.361
MEMBER 8							
0%	0.000	0.000	0.657	33.286	0.000	0.000	1.335
100%	61.000	0.000	0.791	-10.881	0.000	0.000	1.335
MEMBER 9							
0%	0.000	0.000	-0.797	-10.009	0.000	0.000	0.545
100%	61.000	0.000	-0.664	34.528	0.000	0.000	0.545
MEMBER 10							
0%	0.000	0.000	0.399	-1.675	0.000	0.000	2.400
100%	61.000	0.000	0.532	-30.064	0.000	0.000	2.400
MEMBER 11							
0%	0.000	0.000	-1.264	-35.667	0.000	0.000	-1.961
100%	61.000	0.000	-1.131	37.392	0.000	0.000	-1.961

MEMBER 12							
0%	0.000	0.000	1.408	68.453	0.000	0.000	-4.664
100%	61.000	0.000	1.541	-21.496	0.000	0.000	-4.664
MEMBER 13							
0%	0.000	0.000	-0.997	-16.521	0.000	0.000	-2.179
100%	61.000	0.000	-0.863	40.206	0.000	0.000	-2.179
MEMBER 14							
0%	0.000	0.000	0.739	22.479	0.000	0.000	3.134
100%	43.000	0.000	0.833	-11.316	0.000	0.000	3.134
MEMBER 15							
0%	0.000	0.000	-0.735	-11.959	0.000	0.000	1.193
100%	43.000	0.000	-0.641	17.631	0.000	0.000	1.193
MEMBER 16							
0%	0.000	0.000	-1.941	14.579	0.000	0.000	4.787
60%	22.800	0.000	-1.892	58.278	0.000	0.000	4.787
100%	38.000	0.000	3.641	9.780	0.000	0.000	4.787
MEMBER 17							
0%	0.000	0.000	0.508	12.585	0.000	0.000	-4.816
100%	43.000	0.000	0.602	-11.265	0.000	0.000	-4.816
MEMBER 18							
0%	0.000	0.000	-0.180	-7.856	0.000	0.000	-3.434
100%	43.000	0.000	-0.086	-2.149	0.000	0.000	-3.434
MEMBER 19							
0%	0.000	0.000	0.154	0.725	0.000	0.000	-1.678
100%	18.000	0.000	0.193	-2.397	0.000	0.000	-1.678
MEMBER 20							
0%	0.000	0.000	0.692	28.610	0.000	0.000	-3.271
100%	43.000	0.000	0.786	-3.169	0.000	0.000	-3.271
MEMBER 21							
0%	0.000	0.000	-0.293	3.452	0.000	0.000	-4.067
100%	43.000	0.000	-0.200	14.051	0.000	0.000	-4.067
MEMBER 22							
0%	0.000	0.000	0.395	28.519	0.000	0.000	-0.407
100%	38.000	0.000	0.478	11.946	0.000	0.000	-0.407
MEMBER 23							
0%	0.000	0.000	-0.073	-1.397	0.000	0.000	2.590
100%	43.000	0.000	0.021	-0.270	0.000	0.000	2.590
MEMBER 24							
0%	0.000	0.000	-0.218	-7.377	0.000	0.000	-2.543
100%	43.000	0.000	-0.124	-0.021	0.000	0.000	-2.543
MEMBER 25							
0%	0.000	0.000	-0.284	-0.415	0.000	0.000	-5.569
100%	18.000	0.000	-0.245	4.343	0.000	0.000	-5.569
MEMBER 26							
0%	0.000	0.000	4.347	109.146	0.000	0.000	7.730
100%	43.000	0.000	4.441	-79.788	0.000	0.000	7.730
MEMBER 27							
0%	0.000	0.000	-3.788	-85.077	0.000	0.000	-20.120
100%	43.000	0.000	-3.694	75.791	0.000	0.000	-20.120
MEMBER 28							
0%	0.000	0.000	-1.775	62.676	0.000	0.000	-3.636
60%	22.800	0.000	-1.725	102.570	0.000	0.000	-3.636
100%	38.000	0.000	3.808	51.536	0.000	0.000	-3.636
MEMBER 29							
0%	0.000	0.000	3.825	65.586	0.000	0.000	20.862
100%	43.000	0.000	3.919	-100.925	0.000	0.000	20.862
MEMBER 30							
0%	0.000	0.000	-3.715	-97.737	0.000	0.000	-12.134
100%	43.000	0.000	-3.621	59.994	0.000	0.000	-12.134
MEMBER 31							
0%	0.000	0.000	2.787	53.216	0.000	0.000	30.992
100%	18.000	0.000	2.826	2.701	0.000	0.000	30.992
MEMBER 32							
0%	0.000	0.000	3.573	94.257	0.000	0.000	0.598
100%	43.000	0.000	3.666	-61.383	0.000	0.000	0.598
MEMBER 33							
0%	0.000	0.000	-3.041	-63.156	0.000	0.000	0.640
100%	43.000	0.000	-2.947	65.568	0.000	0.000	0.640
MEMBER 34							
0%	0.000	0.000	-0.049	66.868	0.000	0.000	0.130
60%	22.800	0.000	0.000	67.426	0.000	0.000	0.130
100%	38.000	0.000	0.034	67.168	0.000	0.000	0.130

MEMBER 35							
0%	0.000	0.000	3.292	63.982	0.000	0.000	-0.952
100%	43.000	0.000	3.386	-79.578	0.000	0.000	-0.952
MEMBER 36							
0%	0.000	0.000	-3.249	-78.362	0.000	0.000	1.350
100%	43.000	0.000	-3.155	59.320	0.000	0.000	1.350
MEMBER 37							
0%	0.000	0.000	3.580	62.371	0.000	0.000	4.953
100%	18.000	0.000	3.619	-2.422	0.000	0.000	4.953
MEMBER 38							
0%	0.000	0.000	3.966	104.931	0.000	0.000	-15.064
100%	43.000	0.000	4.060	-67.644	0.000	0.000	-15.064
MEMBER 39							
0%	0.000	0.000	-3.121	-66.560	0.000	0.000	24.690
100%	43.000	0.000	-3.027	65.621	0.000	0.000	24.690
MEMBER 40							
0%	0.000	0.000	0.013	66.031	0.000	0.000	0.151
100%	38.000	0.000	0.096	63.951	0.000	0.000	0.151
MEMBER 41							
0%	0.000	0.000	3.318	63.616	0.000	0.000	-24.286
100%	43.000	0.000	3.412	-81.069	0.000	0.000	-24.286
MEMBER 42							
0%	0.000	0.000	-3.628	-81.775	0.000	0.000	15.874
100%	43.000	0.000	-3.534	72.191	0.000	0.000	15.874
MEMBER 43							
0%	0.000	0.000	4.176	73.380	0.000	0.000	-40.146
100%	18.000	0.000	4.215	-2.142	0.000	0.000	-40.146
MEMBER 44							
0%	0.000	0.000	-1.777	-10.845	0.000	0.000	2.264
30%	18.300	0.000	1.263	20.404	0.000	0.000	2.264
100%	61.000	0.000	1.356	-35.526	0.000	0.000	2.264
MEMBER 45							
0%	0.000	0.000	-0.885	-35.768	0.000	0.000	6.784
100%	61.000	0.000	2.249	-39.876	0.000	0.000	6.784
MEMBER 46							
0%	0.000	0.000	-13.467	-79.332	0.000	0.000	1.412
30%	18.300	0.000	6.573	160.744	0.000	0.000	1.412
100%	61.000	0.000	6.666	-121.925	0.000	0.000	1.412
MEMBER 47							
0%	0.000	0.000	-7.059	-124.739	0.000	0.000	-0.186
70%	42.700	0.000	-6.966	174.679	0.000	0.000	-0.186
100%	61.000	0.000	13.074	-58.217	0.000	0.000	-0.186
MEMBER 48							
0%	0.000	0.000	0.390	1.943	0.000	0.000	-0.639
100%	61.000	0.000	0.523	-25.906	0.000	0.000	-0.639
MEMBER 49							
0%	0.000	0.000	-0.715	-25.109	0.000	0.000	5.988
100%	61.000	0.000	-0.581	14.421	0.000	0.000	5.988
MEMBER 50							
0%	0.000	0.000	0.744	42.275	0.000	0.000	0.697
100%	61.000	0.000	0.878	-7.193	0.000	0.000	0.697
MEMBER 51							
0%	0.000	0.000	-0.837	-7.232	0.000	0.000	-1.083
100%	61.000	0.000	-0.704	39.763	0.000	0.000	-1.083
MEMBER 52							
0%	0.000	0.000	-1.072	-3.606	0.000	0.000	-3.044
30%	18.300	0.000	1.968	14.746	0.000	0.000	-3.044
100%	61.000	0.000	2.061	-71.279	0.000	0.000	-3.044
MEMBER 53							
0%	0.000	0.000	-1.966	-74.937	0.000	0.000	11.434
70%	42.700	0.000	-1.873	7.033	0.000	0.000	11.434
100%	61.000	0.000	1.167	-13.056	0.000	0.000	11.434
MEMBER 54							
0%	0.000	0.000	-12.382	-29.589	0.000	0.000	-1.681
30%	18.300	0.000	7.658	190.634	0.000	0.000	-1.681
100%	61.000	0.000	7.751	-138.355	0.000	0.000	-1.681
MEMBER 55							
0%	0.000	0.000	-7.825	-137.847	0.000	0.000	-0.402
70%	42.700	0.000	-7.731	194.276	0.000	0.000	-0.402
100%	61.000	0.000	12.309	-24.604	0.000	0.000	-0.402
MEMBER 56							
0%	0.000	0.000	1.036	9.600	0.000	0.000	2.799
100%	61.000	0.000	1.169	-57.641	0.000	0.000	2.799

MEMBER 57							
0%	0.000	0.000	-1.122	-60.638	0.000	0.000	-10.551
100%	61.000	0.000	-0.989	3.735	0.000	0.000	-10.551
MEMBER 58							
0%	0.000	0.000	-12.228	-20.824	0.000	0.000	3.495
30%	18.300	0.000	7.812	196.581	0.000	0.000	3.495
100%	61.000	0.000	7.905	-138.986	0.000	0.000	3.495
MEMBER 59							
0%	0.000	0.000	-7.827	-137.903	0.000	0.000	0.327
70%	42.700	0.000	-7.734	194.331	0.000	0.000	0.327
100%	61.000	0.000	12.306	-24.502	0.000	0.000	0.327
MEMBER 60							
0%	0.000	0.000	0.379	-1.383	0.000	0.000	3.406
100%	61.000	0.000	0.512	-28.555	0.000	0.000	3.406
MEMBER 61							
0%	0.000	0.000	-0.634	-23.422	0.000	0.000	-3.706
100%	61.000	0.000	-0.501	11.183	0.000	0.000	-3.706
MEMBER 62							
0%	0.000	0.000	0.716	44.183	0.000	0.000	-0.519
100%	61.000	0.000	0.849	-3.542	0.000	0.000	-0.519
MEMBER 63							
0%	0.000	0.000	-0.821	-5.842	0.000	0.000	0.704
100%	61.000	0.000	-0.688	40.169	0.000	0.000	0.704
MEMBER 64							
0%	0.000	0.000	0.331	-1.760	0.000	0.000	2.876
100%	61.000	0.000	0.464	-25.998	0.000	0.000	2.876
MEMBER 65							
0%	0.000	0.000	-0.234	-22.940	0.000	0.000	2.463
100%	61.000	0.000	-0.101	-12.744	0.000	0.000	2.463
MEMBER 66							
0%	0.000	0.000	-13.047	-55.980	0.000	0.000	-4.321
30%	18.300	0.000	6.993	176.410	0.000	0.000	-4.321
100%	61.000	0.000	7.086	-124.190	0.000	0.000	-4.321
MEMBER 67							
0%	0.000	0.000	-7.143	-127.815	0.000	0.000	-1.218
70%	42.700	0.000	-7.050	175.221	0.000	0.000	-1.218
100%	61.000	0.000	12.990	-56.126	0.000	0.000	-1.218
MEMBER 68							
0%	0.000	0.000	-0.741	7.235	0.000	0.000	-7.695
100%	18.000	0.000	-0.701	20.214	0.000	0.000	-7.695
MEMBER 69							
0%	0.000	0.000	-0.428	16.754	0.000	0.000	-3.534
100%	18.000	0.000	-0.388	24.101	0.000	0.000	-3.534
MEMBER 70							
0%	0.000	0.000	-6.179	3.635	0.000	0.000	-31.628
100%	18.000	0.000	-6.140	114.501	0.000	0.000	-31.628
MEMBER 71							
0%	0.000	0.000	-4.151	21.439	0.000	0.000	-2.203
100%	18.000	0.000	-4.111	95.795	0.000	0.000	-2.203
MEMBER 72							
0%	0.000	0.000	-4.665	21.098	0.000	0.000	43.042
100%	18.000	0.000	-4.626	104.716	0.000	0.000	43.042
MEMBER 73							
0%	0.000	0.000	0.105	2.790	0.000	0.000	4.287
100%	61.000	0.000	0.239	-7.704	0.000	0.000	4.287
MEMBER 74							
0%	0.000	0.000	-0.017	-0.108	0.000	0.000	12.261
100%	61.000	0.000	0.116	-3.104	0.000	0.000	12.261
MEMBER 75							
0%	0.000	0.000	0.084	8.024	0.000	0.000	3.095
100%	61.000	0.000	0.218	-1.191	0.000	0.000	3.095
MEMBER 76							
0%	0.000	0.000	-0.205	0.153	0.000	0.000	0.696
100%	61.000	0.000	-0.071	8.576	0.000	0.000	0.696

Condit.: LC3=DL+SC+TK2+SP

Station	Dist to J [in]	Axial [Kip]	Plane 1-2		Plane 1-3		Torsion [Kip*in]
			Shear V2 [Kip]	M33 [Kip*in]	Shear V3 [Kip]	M22 [Kip*in]	

MEMBER 1							
0%	0.000	0.000	-0.877	-1.082	0.000	0.000	-8.033
100%	28.000	0.000	-0.816	22.614	0.000	0.000	-8.033
MEMBER 2							
0%	0.000	0.000	-0.958	-2.411	0.000	0.000	1.661
100%	28.000	0.000	-0.897	23.549	0.000	0.000	1.661
MEMBER 3							
0%	0.000	0.000	-0.917	-9.166	0.000	0.000	11.325
100%	28.000	0.000	-0.856	15.645	0.000	0.000	11.325
MEMBER 4							
0%	0.000	0.000	0.061	7.986	0.000	0.000	7.913
100%	28.000	0.000	0.122	5.432	0.000	0.000	7.913
MEMBER 5							
0%	0.000	0.000	0.035	4.673	0.000	0.000	3.333
100%	28.000	0.000	0.097	2.826	0.000	0.000	3.333
MEMBER 6							
0%	0.000	0.000	0.654	33.831	0.000	0.000	-1.030
100%	61.000	0.000	0.787	-10.096	0.000	0.000	-1.030
MEMBER 7							
0%	0.000	0.000	-0.782	-10.755	0.000	0.000	-1.553
100%	61.000	0.000	-0.649	32.872	0.000	0.000	-1.553
MEMBER 8							
0%	0.000	0.000	0.504	13.137	0.000	0.000	-13.579
100%	61.000	0.000	0.637	-21.680	0.000	0.000	-13.579
MEMBER 9							
0%	0.000	0.000	-0.444	-17.387	0.000	0.000	-3.890
100%	61.000	0.000	-0.310	5.608	0.000	0.000	-3.890
MEMBER 10							
0%	0.000	0.000	0.385	-2.077	0.000	0.000	3.085
100%	61.000	0.000	0.518	-29.620	0.000	0.000	3.085
MEMBER 11							
0%	0.000	0.000	-1.282	-36.160	0.000	0.000	-1.143
100%	61.000	0.000	-1.149	37.997	0.000	0.000	-1.143
MEMBER 12							
0%	0.000	0.000	1.390	67.849	0.000	0.000	-3.846
100%	61.000	0.000	1.523	-21.003	0.000	0.000	-3.846
MEMBER 13							
0%	0.000	0.000	-1.010	-16.966	0.000	0.000	-1.494
100%	61.000	0.000	-0.877	40.608	0.000	0.000	-1.494
MEMBER 14							
0%	0.000	0.000	3.607	108.040	0.000	0.000	17.843
100%	43.000	0.000	3.701	-49.095	0.000	0.000	17.843
MEMBER 15							
0%	0.000	0.000	-3.510	-49.410	0.000	0.000	-16.806
100%	43.000	0.000	-3.416	99.497	0.000	0.000	-16.806
MEMBER 16							
0%	0.000	0.000	1.012	98.771	0.000	0.000	25.736
100%	38.000	0.000	6.595	-18.278	0.000	0.000	25.736
MEMBER 17							
0%	0.000	0.000	0.554	-11.684	0.000	0.000	-2.549
100%	43.000	0.000	0.648	-37.512	0.000	0.000	-2.549
MEMBER 18							
0%	0.000	0.000	-0.614	-31.948	0.000	0.000	-3.772
100%	43.000	0.000	-0.521	-7.544	0.000	0.000	-3.772
MEMBER 19							
0%	0.000	0.000	-0.062	-3.839	0.000	0.000	-2.081
100%	18.000	0.000	-0.022	-3.082	0.000	0.000	-2.081
MEMBER 20							
0%	0.000	0.000	3.244	99.839	0.000	0.000	-1.502
100%	43.000	0.000	3.338	-41.663	0.000	0.000	-1.502
MEMBER 21							
0%	0.000	0.000	-2.960	-36.594	0.000	0.000	-4.978
100%	43.000	0.000	-2.866	88.655	0.000	0.000	-4.978
MEMBER 22							
0%	0.000	0.000	3.241	106.579	0.000	0.000	-7.352
100%	38.000	0.000	3.324	-18.173	0.000	0.000	-7.352

MEMBER 23							
0%	0.000	0.000	0.005	-20.942	0.000	0.000	-3.921
100%	43.000	0.000	0.098	-23.156	0.000	0.000	-3.921
MEMBER 24							
0%	0.000	0.000	-0.580	-26.644	0.000	0.000	-4.930
100%	43.000	0.000	-0.486	-3.709	0.000	0.000	-4.930
MEMBER 25							
0%	0.000	0.000	-0.466	-3.817	0.000	0.000	-6.506
100%	18.000	0.000	-0.426	4.210	0.000	0.000	-6.506
MEMBER 26							
0%	0.000	0.000	4.347	109.146	0.000	0.000	-11.653
100%	43.000	0.000	4.441	-79.788	0.000	0.000	-11.653
MEMBER 27							
0%	0.000	0.000	-3.788	-85.077	0.000	0.000	4.162
100%	43.000	0.000	-3.694	75.791	0.000	0.000	4.162
MEMBER 28							
0%	0.000	0.000	-1.775	62.676	0.000	0.000	-46.107
60%	22.800	0.000	-1.725	102.570	0.000	0.000	-46.107
100%	38.000	0.000	3.808	51.536	0.000	0.000	-46.107
MEMBER 29							
0%	0.000	0.000	3.825	65.586	0.000	0.000	6.886
100%	43.000	0.000	3.919	-100.925	0.000	0.000	6.886
MEMBER 30							
0%	0.000	0.000	-3.715	-97.737	0.000	0.000	-15.974
100%	43.000	0.000	-3.621	59.994	0.000	0.000	-15.974
MEMBER 31							
0%	0.000	0.000	2.787	53.216	0.000	0.000	29.782
100%	18.000	0.000	2.826	2.701	0.000	0.000	29.782
MEMBER 32							
0%	0.000	0.000	1.021	23.028	0.000	0.000	2.368
100%	43.000	0.000	1.115	-22.888	0.000	0.000	2.368
MEMBER 33							
0%	0.000	0.000	-0.374	-23.110	0.000	0.000	-0.272
100%	43.000	0.000	-0.280	-9.035	0.000	0.000	-0.272
MEMBER 34							
0%	0.000	0.000	-2.896	-11.192	0.000	0.000	-6.815
100%	38.000	0.000	-2.813	97.287	0.000	0.000	-6.815
MEMBER 35							
0%	0.000	0.000	3.214	83.527	0.000	0.000	-7.463
100%	43.000	0.000	3.308	-56.693	0.000	0.000	-7.463
MEMBER 36							
0%	0.000	0.000	-2.887	-59.095	0.000	0.000	-1.038
100%	43.000	0.000	-2.793	63.008	0.000	0.000	-1.038
MEMBER 37							
0%	0.000	0.000	3.762	65.772	0.000	0.000	4.015
100%	18.000	0.000	3.801	-2.289	0.000	0.000	4.015
MEMBER 38							
0%	0.000	0.000	1.098	19.370	0.000	0.000	-0.355
100%	43.000	0.000	1.192	-29.864	0.000	0.000	-0.355
MEMBER 39							
0%	0.000	0.000	-0.346	-29.109	0.000	0.000	6.692
100%	43.000	0.000	-0.252	-16.245	0.000	0.000	6.692
MEMBER 40							
0%	0.000	0.000	-2.941	-18.161	0.000	0.000	21.100
100%	38.000	0.000	-2.858	92.008	0.000	0.000	21.100
MEMBER 41							
0%	0.000	0.000	3.272	87.884	0.000	0.000	-22.020
100%	43.000	0.000	3.366	-54.821	0.000	0.000	-22.020
MEMBER 42							
0%	0.000	0.000	-3.193	-57.683	0.000	0.000	15.537
100%	43.000	0.000	-3.099	77.586	0.000	0.000	15.537
MEMBER 43							
0%	0.000	0.000	4.392	77.944	0.000	0.000	-40.548
100%	18.000	0.000	4.431	-1.457	0.000	0.000	-40.548
MEMBER 44							
0%	0.000	0.000	-13.093	-59.756	0.000	0.000	-0.468
30%	18.300	0.000	6.947	173.480	0.000	0.000	-0.468
100%	61.000	0.000	7.040	-125.145	0.000	0.000	-0.468
MEMBER 45							
0%	0.000	0.000	-6.630	-121.324	0.000	0.000	-1.097
70%	42.700	0.000	-6.536	159.773	0.000	0.000	-1.097
100%	61.000	0.000	13.504	-80.976	0.000	0.000	-1.097

MEMBER 46							
0%	0.000	0.000	-2.212	-38.232	0.000	0.000	-6.469
100%	61.000	0.000	0.921	-36.369	0.000	0.000	-6.469
MEMBER 47							
0%	0.000	0.000	-1.375	-35.120	0.000	0.000	-2.918
70%	42.700	0.000	-1.282	21.604	0.000	0.000	-2.918
100%	61.000	0.000	1.758	-9.306	0.000	0.000	-2.918
MEMBER 48							
0%	0.000	0.000	0.716	34.655	0.000	0.000	-0.312
100%	61.000	0.000	0.849	-13.071	0.000	0.000	-0.312
MEMBER 49							
0%	0.000	0.000	-0.818	-9.600	0.000	0.000	4.762
100%	61.000	0.000	-0.685	36.258	0.000	0.000	4.762
MEMBER 50							
0%	0.000	0.000	0.641	20.438	0.000	0.000	-0.530
100%	61.000	0.000	0.774	-22.702	0.000	0.000	-0.530
MEMBER 51							
0%	0.000	0.000	-0.511	-20.067	0.000	0.000	-0.756
100%	61.000	0.000	-0.378	7.051	0.000	0.000	-0.756
MEMBER 52							
0%	0.000	0.000	-12.230	-42.617	0.000	0.000	-0.713
30%	18.300	0.000	7.810	174.824	0.000	0.000	-0.713
100%	61.000	0.000	7.903	-160.659	0.000	0.000	-0.713
MEMBER 53							
0%	0.000	0.000	-7.801	-158.283	0.000	0.000	17.233
70%	42.700	0.000	-7.708	172.827	0.000	0.000	17.233
100%	61.000	0.000	12.332	-46.487	0.000	0.000	17.233
MEMBER 54							
0%	0.000	0.000	-1.217	3.842	0.000	0.000	4.118
30%	18.300	0.000	1.823	24.840	0.000	0.000	4.118
100%	61.000	0.000	1.917	-55.009	0.000	0.000	4.118
MEMBER 55							
0%	0.000	0.000	-1.983	-48.467	0.000	0.000	1.929
70%	42.700	0.000	-1.889	34.198	0.000	0.000	1.929
100%	61.000	0.000	1.151	14.407	0.000	0.000	1.929
MEMBER 56							
0%	0.000	0.000	1.205	28.289	0.000	0.000	6.602
100%	61.000	0.000	1.338	-49.271	0.000	0.000	6.602
MEMBER 57							
0%	0.000	0.000	-1.225	-52.704	0.000	0.000	3.860
100%	61.000	0.000	-1.092	17.988	0.000	0.000	3.860
MEMBER 58							
0%	0.000	0.000	-12.331	-35.076	0.000	0.000	17.906
30%	18.300	0.000	7.709	184.224	0.000	0.000	17.906
100%	61.000	0.000	7.802	-146.920	0.000	0.000	17.906
MEMBER 59							
0%	0.000	0.000	-7.658	-146.272	0.000	0.000	4.130
70%	42.700	0.000	-7.565	178.738	0.000	0.000	4.130
100%	61.000	0.000	12.475	-43.191	0.000	0.000	4.130
MEMBER 60							
0%	0.000	0.000	0.373	1.225	0.000	0.000	5.566
100%	61.000	0.000	0.506	-25.561	0.000	0.000	5.566
MEMBER 61							
0%	0.000	0.000	-0.735	-24.549	0.000	0.000	2.079
100%	61.000	0.000	-0.602	16.250	0.000	0.000	2.079
MEMBER 62							
0%	0.000	0.000	0.614	39.116	0.000	0.000	5.266
100%	61.000	0.000	0.747	-2.415	0.000	0.000	5.266
MEMBER 63							
0%	0.000	0.000	-0.827	-8.836	0.000	0.000	2.863
100%	61.000	0.000	-0.694	37.561	0.000	0.000	2.863
MEMBER 64							
0%	0.000	0.000	0.323	-1.695	0.000	0.000	3.708
100%	61.000	0.000	0.456	-25.474	0.000	0.000	3.708
MEMBER 65							
0%	0.000	0.000	-0.270	-23.865	0.000	0.000	3.582
100%	61.000	0.000	-0.137	-11.429	0.000	0.000	3.582
MEMBER 66							
0%	0.000	0.000	-13.083	-57.294	0.000	0.000	-3.202
30%	18.300	0.000	6.956	175.768	0.000	0.000	-3.202
100%	61.000	0.000	7.050	-123.265	0.000	0.000	-3.202

MEMBER 67							
0%	0.000	0.000	-7.151	-128.339	0.000	0.000	-0.387
70%	42.700	0.000	-7.058	175.018	0.000	0.000	-0.387
100%	61.000	0.000	12.982	-56.191	0.000	0.000	-0.387
MEMBER 68							
0%	0.000	0.000	-4.845	21.616	0.000	0.000	-41.802
100%	18.000	0.000	-4.806	108.480	0.000	0.000	-41.802
MEMBER 69							
0%	0.000	0.000	-4.316	23.085	0.000	0.000	2.307
100%	18.000	0.000	-4.276	100.411	0.000	0.000	2.307
MEMBER 70							
0%	0.000	0.000	-6.179	3.635	0.000	0.000	30.996
100%	18.000	0.000	-6.140	114.501	0.000	0.000	30.996
MEMBER 71							
0%	0.000	0.000	-0.263	15.108	0.000	0.000	3.639
100%	18.000	0.000	-0.223	19.484	0.000	0.000	3.639
MEMBER 72							
0%	0.000	0.000	-0.560	6.718	0.000	0.000	8.935
100%	18.000	0.000	-0.521	16.450	0.000	0.000	8.935
MEMBER 73							
0%	0.000	0.000	0.061	8.033	0.000	0.000	-1.082
100%	61.000	0.000	0.194	0.272	0.000	0.000	-1.082
MEMBER 74							
0%	0.000	0.000	-0.223	-1.389	0.000	0.000	-3.493
100%	61.000	0.000	-0.089	8.122	0.000	0.000	-3.493
MEMBER 75							
0%	0.000	0.000	-0.121	-3.203	0.000	0.000	-12.660
90%	54.900	0.000	-0.001	0.127	0.000	0.000	-12.660
100%	61.000	0.000	0.013	0.090	0.000	0.000	-12.660
MEMBER 76							
0%	0.000	0.000	-0.249	-7.823	0.000	0.000	-4.673
100%	61.000	0.000	-0.116	3.333	0.000	0.000	-4.673

Condit.: LC4=DL+SC+TK3+SP

Station	Dist to J [in]	Axial [Kip]	Plane 1-2		Plane 1-3		Torsion [Kip*in]
			Shear V2 [Kip]	M33 [Kip*in]	Shear V3 [Kip]	M22 [Kip*in]	
MEMBER 1							
0%	0.000	0.000	-0.751	2.314	0.000	0.000	-8.864
100%	28.000	0.000	-0.690	22.486	0.000	0.000	-8.864
MEMBER 2							
0%	0.000	0.000	-0.774	5.464	0.000	0.000	-4.908
100%	28.000	0.000	-0.713	26.288	0.000	0.000	-4.908
MEMBER 3							
0%	0.000	0.000	-1.603	-15.727	0.000	0.000	0.047
100%	28.000	0.000	-1.542	28.300	0.000	0.000	0.047
MEMBER 4							
0%	0.000	0.000	-0.795	5.323	0.000	0.000	5.179
100%	28.000	0.000	-0.734	26.723	0.000	0.000	5.179
MEMBER 5							
0%	0.000	0.000	-0.806	2.625	0.000	0.000	9.399
100%	28.000	0.000	-0.745	24.328	0.000	0.000	9.399
MEMBER 6							
0%	0.000	0.000	0.895	33.748	0.000	0.000	1.394
100%	61.000	0.000	1.029	-24.932	0.000	0.000	1.394
MEMBER 7							
0%	0.000	0.000	-1.217	-29.480	0.000	0.000	10.317
100%	61.000	0.000	-1.084	40.702	0.000	0.000	10.317
MEMBER 8							
0%	0.000	0.000	1.082	40.747	0.000	0.000	-10.526
100%	61.000	0.000	1.215	-29.297	0.000	0.000	-10.526
MEMBER 9							
0%	0.000	0.000	-1.042	-25.002	0.000	0.000	-1.951
100%	61.000	0.000	-0.909	34.494	0.000	0.000	-1.951
MEMBER 10							
0%	0.000	0.000	0.065	-1.835	0.000	0.000	3.167
100%	61.000	0.000	0.198	-9.840	0.000	0.000	3.167
MEMBER 11							
0%	0.000	0.000	-0.829	-15.332	0.000	0.000	5.285
100%	61.000	0.000	-0.696	31.173	0.000	0.000	5.285

MEMBER 12							
0%	0.000	0.000	0.721	35.494	0.000	0.000	-5.344
100%	61.000	0.000	0.854	-12.566	0.000	0.000	-5.344
MEMBER 13							
0%	0.000	0.000	-0.304	-8.380	0.000	0.000	-1.745
100%	61.000	0.000	-0.171	6.086	0.000	0.000	-1.745
MEMBER 14							
0%	0.000	0.000	3.657	109.867	0.000	0.000	18.012
100%	43.000	0.000	3.751	-49.405	0.000	0.000	18.012
MEMBER 15							
0%	0.000	0.000	-3.563	-51.069	0.000	0.000	-15.588
100%	43.000	0.000	-3.469	100.117	0.000	0.000	-15.588
MEMBER 16							
0%	0.000	0.000	0.875	95.719	0.000	0.000	26.787
100%	38.000	0.000	6.458	-16.111	0.000	0.000	26.787
MEMBER 17							
0%	0.000	0.000	0.496	-13.224	0.000	0.000	-1.135
100%	43.000	0.000	0.590	-36.589	0.000	0.000	-1.135
MEMBER 18							
0%	0.000	0.000	-0.621	-32.832	0.000	0.000	-2.940
100%	43.000	0.000	-0.527	-8.147	0.000	0.000	-2.940
MEMBER 19							
0%	0.000	0.000	-0.113	-4.835	0.000	0.000	-1.838
100%	18.000	0.000	-0.073	-3.164	0.000	0.000	-1.838
MEMBER 20							
0%	0.000	0.000	3.273	107.791	0.000	0.000	-1.866
100%	43.000	0.000	3.367	-34.981	0.000	0.000	-1.866
MEMBER 21							
0%	0.000	0.000	-2.936	-30.884	0.000	0.000	0.180
100%	43.000	0.000	-2.842	93.361	0.000	0.000	0.180
MEMBER 22							
0%	0.000	0.000	2.918	100.080	0.000	0.000	1.496
100%	38.000	0.000	3.001	-12.372	0.000	0.000	1.496
MEMBER 23							
0%	0.000	0.000	-0.013	-26.301	0.000	0.000	1.519
100%	43.000	0.000	0.081	-27.772	0.000	0.000	1.519
MEMBER 24							
0%	0.000	0.000	-0.659	-32.559	0.000	0.000	-3.647
100%	43.000	0.000	-0.565	-6.247	0.000	0.000	-3.647
MEMBER 25							
0%	0.000	0.000	-0.132	-4.149	0.000	0.000	-5.475
100%	18.000	0.000	-0.093	-2.123	0.000	0.000	-5.475
MEMBER 26							
0%	0.000	0.000	6.875	190.403	0.000	0.000	-0.190
100%	43.000	0.000	6.969	-107.251	0.000	0.000	-0.190
MEMBER 27							
0%	0.000	0.000	-6.734	-112.282	0.000	0.000	-1.072
100%	43.000	0.000	-6.640	175.254	0.000	0.000	-1.072
MEMBER 28							
0%	0.000	0.000	3.994	171.905	0.000	0.000	-3.722
100%	38.000	0.000	9.577	-58.459	0.000	0.000	-3.722
MEMBER 29							
0%	0.000	0.000	0.740	-34.695	0.000	0.000	2.006
100%	43.000	0.000	0.834	-68.527	0.000	0.000	2.006
MEMBER 30							
0%	0.000	0.000	-1.435	-65.073	0.000	0.000	-2.314
100%	43.000	0.000	-1.341	-5.394	0.000	0.000	-2.314
MEMBER 31							
0%	0.000	0.000	-1.470	-15.489	0.000	0.000	4.309
100%	18.000	0.000	-1.430	10.613	0.000	0.000	4.309
MEMBER 32							
0%	0.000	0.000	3.274	107.552	0.000	0.000	3.027
100%	43.000	0.000	3.368	-35.246	0.000	0.000	3.027
MEMBER 33							
0%	0.000	0.000	-2.926	-34.319	0.000	0.000	1.814
100%	43.000	0.000	-2.832	89.466	0.000	0.000	1.814
MEMBER 34							
0%	0.000	0.000	2.449	90.091	0.000	0.000	-1.881
100%	38.000	0.000	2.532	-4.534	0.000	0.000	-1.881
MEMBER 35							
0%	0.000	0.000	0.446	-15.637	0.000	0.000	-4.936
100%	43.000	0.000	0.539	-36.815	0.000	0.000	-4.936

MEMBER 36							
0%	0.000	0.000	-1.000	-38.187	0.000	0.000	1.269
100%	43.000	0.000	-0.906	2.783	0.000	0.000	1.269
MEMBER 37							
0%	0.000	0.000	0.524	6.199	0.000	0.000	4.172
100%	18.000	0.000	0.563	-3.590	0.000	0.000	4.172
MEMBER 38							
0%	0.000	0.000	3.621	114.535	0.000	0.000	-15.212
100%	43.000	0.000	3.715	-43.201	0.000	0.000	-15.212
MEMBER 39							
0%	0.000	0.000	-3.113	-41.531	0.000	0.000	21.030
100%	43.000	0.000	-3.019	90.321	0.000	0.000	21.030
MEMBER 40							
0%	0.000	0.000	2.779	90.700	0.000	0.000	-21.841
100%	38.000	0.000	2.862	-16.468	0.000	0.000	-21.841
MEMBER 41							
0%	0.000	0.000	0.260	-18.132	0.000	0.000	-7.180
100%	43.000	0.000	0.354	-31.341	0.000	0.000	-7.180
MEMBER 42							
0%	0.000	0.000	-0.997	-32.390	0.000	0.000	1.676
100%	43.000	0.000	-0.903	8.475	0.000	0.000	1.676
MEMBER 43							
0%	0.000	0.000	0.619	9.753	0.000	0.000	-6.073
100%	18.000	0.000	0.658	-1.737	0.000	0.000	-6.073
MEMBER 44							
0%	0.000	0.000	-12.846	-60.672	0.000	0.000	0.849
30%	18.300	0.000	7.194	168.041	0.000	0.000	0.849
100%	61.000	0.000	7.287	-141.138	0.000	0.000	0.849
MEMBER 45							
0%	0.000	0.000	-6.577	-139.630	0.000	0.000	4.540
70%	42.700	0.000	-6.483	139.201	0.000	0.000	4.540
100%	61.000	0.000	13.557	-102.519	0.000	0.000	4.540
MEMBER 46							
0%	0.000	0.000	-13.563	-102.326	0.000	0.000	-4.800
30%	18.300	0.000	6.477	139.506	0.000	0.000	-4.800
100%	61.000	0.000	6.570	-139.063	0.000	0.000	-4.800
MEMBER 47							
0%	0.000	0.000	-7.313	-141.208	0.000	0.000	-1.869
70%	42.700	0.000	-7.220	169.083	0.000	0.000	-1.869
100%	61.000	0.000	12.820	-59.154	0.000	0.000	-1.869
MEMBER 48							
0%	0.000	0.000	0.980	33.608	0.000	0.000	-1.662
100%	61.000	0.000	1.113	-30.236	0.000	0.000	-1.662
MEMBER 49							
0%	0.000	0.000	-1.383	-32.283	0.000	0.000	2.437
100%	61.000	0.000	-1.250	48.000	0.000	0.000	2.437
MEMBER 50							
0%	0.000	0.000	1.204	48.881	0.000	0.000	-2.596
100%	61.000	0.000	1.337	-28.636	0.000	0.000	-2.596
MEMBER 51							
0%	0.000	0.000	-1.110	-27.422	0.000	0.000	-1.671
100%	61.000	0.000	-0.977	36.248	0.000	0.000	-1.671
MEMBER 52							
0%	0.000	0.000	-12.084	-42.448	0.000	0.000	-4.392
30%	18.300	0.000	7.956	172.318	0.000	0.000	-4.392
100%	61.000	0.000	8.050	-169.406	0.000	0.000	-4.392
MEMBER 53							
0%	0.000	0.000	-7.613	-170.719	0.000	0.000	2.337
70%	42.700	0.000	-7.520	152.361	0.000	0.000	2.337
100%	61.000	0.000	12.520	-70.396	0.000	0.000	2.337
MEMBER 54							
0%	0.000	0.000	-12.673	-67.745	0.000	0.000	-1.005
30%	18.300	0.000	7.366	157.814	0.000	0.000	-1.005
100%	61.000	0.000	7.460	-158.725	0.000	0.000	-1.005
MEMBER 55							
0%	0.000	0.000	-7.806	-155.035	0.000	0.000	-0.379
70%	42.700	0.000	-7.713	176.285	0.000	0.000	-0.379
100%	61.000	0.000	12.327	-42.940	0.000	0.000	-0.379
MEMBER 56							
0%	0.000	0.000	1.057	27.924	0.000	0.000	2.890
100%	61.000	0.000	1.191	-40.638	0.000	0.000	2.890

MEMBER 57							
0%	0.000	0.000	-1.423	-40.665	0.000	0.000	-11.024
100%	61.000	0.000	-1.289	42.049	0.000	0.000	-11.024
MEMBER 58							
0%	0.000	0.000	-0.880	36.311	0.000	0.000	12.742
30%	18.300	0.000	2.160	51.140	0.000	0.000	12.742
100%	61.000	0.000	2.254	-43.101	0.000	0.000	12.742
MEMBER 59							
0%	0.000	0.000	-1.849	-40.042	0.000	0.000	1.656
70%	42.700	0.000	-1.755	36.901	0.000	0.000	1.656
100%	61.000	0.000	1.285	14.658	0.000	0.000	1.656
MEMBER 60							
0%	0.000	0.000	0.095	1.807	0.000	0.000	3.756
100%	61.000	0.000	0.228	-8.035	0.000	0.000	3.756
MEMBER 61							
0%	0.000	0.000	-0.203	-2.869	0.000	0.000	-1.032
100%	61.000	0.000	-0.070	5.442	0.000	0.000	-1.032
MEMBER 62							
0%	0.000	0.000	0.019	9.763	0.000	0.000	2.421
100%	61.000	0.000	0.152	4.546	0.000	0.000	2.421
MEMBER 63							
0%	0.000	0.000	-0.239	-1.660	0.000	0.000	1.050
100%	61.000	0.000	-0.106	8.856	0.000	0.000	1.050
MEMBER 64							
0%	0.000	0.000	0.028	-1.106	0.000	0.000	3.314
100%	61.000	0.000	0.161	-6.848	0.000	0.000	3.314
MEMBER 65							
0%	0.000	0.000	-0.326	-5.005	0.000	0.000	5.404
100%	61.000	0.000	-0.193	10.835	0.000	0.000	5.404
MEMBER 66							
0%	0.000	0.000	-1.798	4.195	0.000	0.000	-4.707
30%	18.300	0.000	1.242	35.832	0.000	0.000	-4.707
100%	61.000	0.000	1.335	-19.193	0.000	0.000	-4.707
MEMBER 67							
0%	0.000	0.000	-1.187	-22.107	0.000	0.000	-1.285
70%	42.700	0.000	-1.094	26.583	0.000	0.000	-1.285
100%	61.000	0.000	1.946	-7.769	0.000	0.000	-1.285
MEMBER 68							
0%	0.000	0.000	-4.747	23.909	0.000	0.000	-42.553
100%	18.000	0.000	-4.707	108.993	0.000	0.000	-42.553
MEMBER 69							
0%	0.000	0.000	-3.842	35.249	0.000	0.000	-0.388
100%	18.000	0.000	-3.803	104.059	0.000	0.000	-0.388
MEMBER 70							
0%	0.000	0.000	-10.699	7.483	0.000	0.000	0.002
100%	18.000	0.000	-10.660	199.716	0.000	0.000	0.002
MEMBER 71							
0%	0.000	0.000	-3.866	35.337	0.000	0.000	0.912
100%	18.000	0.000	-3.827	104.578	0.000	0.000	0.912
MEMBER 72							
0%	0.000	0.000	-4.816	26.309	0.000	0.000	43.833
100%	18.000	0.000	-4.776	112.639	0.000	0.000	43.833
MEMBER 73							
0%	0.000	0.000	0.183	8.864	0.000	0.000	2.314
100%	61.000	0.000	0.316	-6.344	0.000	0.000	2.314
MEMBER 74							
0%	0.000	0.000	-0.168	-1.436	0.000	0.000	7.778
100%	61.000	0.000	-0.035	4.772	0.000	0.000	7.778
MEMBER 75							
0%	0.000	0.000	0.035	4.726	0.000	0.000	-7.948
100%	61.000	0.000	0.168	-1.445	0.000	0.000	-7.948
MEMBER 76							
0%	0.000	0.000	-0.329	-6.624	0.000	0.000	-2.625
100%	61.000	0.000	-0.196	9.399	0.000	0.000	-2.625

DESIGN BY GROUP FOR CONTROLLING LOAD CONDITION

File : C:\Current Projects\V-Tank Analysis\Skid Design\TnkSkid4.AVW
 Units : Kip-in
 Date : 7/13/2004
 Time : 1:18:00 PM

DESIGN CODE : A S D

C O D E C H E C K

MAX. INTERACTION RATIO PER DESCRIPTION

B.Ratio= Bending and axial interaction ratio

S.Ratio = Shear interaction ratio

Stat.b = Station where max. B.Ratio occurs

Stat.v = Station where max. S.Ratio occurs

NOTE.- Non-steel members are not printed

Important.- Maximum values will only be computed from
 currently selected elements

MAX. INTERACTION RATIO IN DESCRIPTION : CrossBeam

OCCURS AT MEMBER : 53

OCCURS FOR CONDITION : LC1=DL+TK+SP

DESIGN STATUS : OK

B.RATIO	Eqn	STAT.B[in]	Axial[Kip]	M33[Kip*in]	M22[Kip*in]
0.35	F4-1	0.00	0.00	-185.81	0.00

S.RATIO	Eqn	STAT.V[in]	V2[Kip]	V3[Kip]	Tor[Kip*in]
0.24	F4-1	61.00	12.22	0.00	13.45

MAX. INTERACTION RATIO IN DESCRIPTION : EndBeam

OCCURS AT MEMBER : 12

OCCURS FOR CONDITION : LC2=DL+SC+TK1+SP

DESIGN STATUS : OK

B.RATIO	Eqn	STAT.B[in]	Axial[Kip]	M33[Kip*in]	M22[Kip*in]
0.13	F4-1	0.00	0.00	68.45	0.00

S.RATIO	Eqn	STAT.V[in]	V2[Kip]	V3[Kip]	Tor[Kip*in]
0.04	F4-1	61.00	1.54	0.00	-4.66

MAX. INTERACTION RATIO IN DESCRIPTION : MainBeam

OCCURS AT MEMBER : 70

OCCURS FOR CONDITION : LC4=DL+SC+TK3+SP

DESIGN STATUS : OK

B.RATIO	Eqn	STAT.B[in]	Axial[Kip]	M33[Kip*in]	M22[Kip*in]
0.37	F4-1	18.00	0.00	199.72	0.00

S.RATIO	Eqn	STAT.V[in]	V2[Kip]	V3[Kip]	Tor[Kip*in]
0.19	F4-1	0.00	-10.70	0.00	0.00

GROUND SUPPORT EVALUATION

The consolidation tank system (tanks, containment pan, shield ϕ 's, & skid) will be placed on the ground & enclosed in a fabric structure.

The proposed location of the system is an area north of TAN-666, which is approximately 200' north-west of the V-tank site.

The area is currently vacant & requires clearing & grubbing of vegetation. Pit run gravel fill will be required to obtain a stable soil.

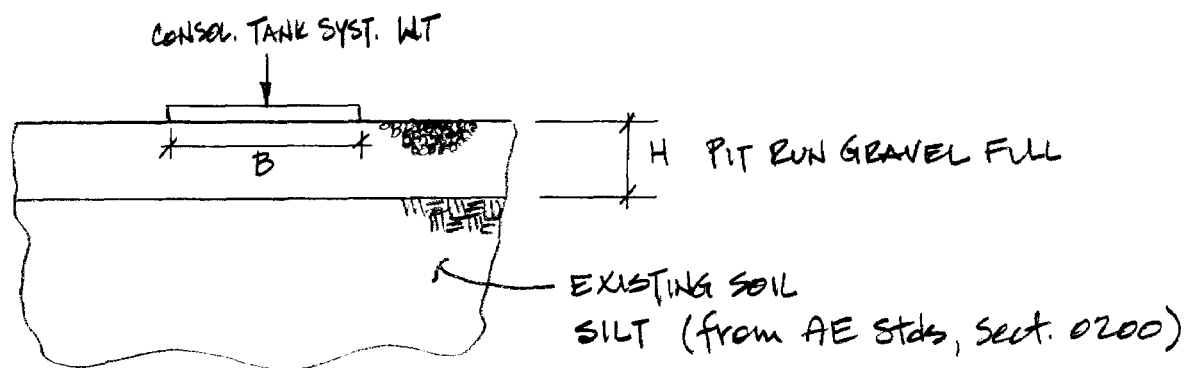

$$\left. \begin{array}{l} \text{Pit Run Gravel: } \phi_1 = 35^\circ \text{ \& } \gamma_1 = 125 \text{ pcf} \\ \text{Silt: } \phi_2 = 28^\circ \text{ \& } \gamma_2 = 100 \text{ pcf} \end{array} \right\} \text{conservative soil parameters}$$

Will use Ref 11, p472 (see attached sheets) to determine required depth of gravel over existing soil by means of allowable bearing capacity.

Loads

$$\text{Tank wt} = 80^k$$

$$\text{Pan wt} = 6^k$$

$$\text{skid wt} = 8.6^k$$

$$\text{shield wt} = 7.7^k$$

Soil Bearing Pressure

conservatively assume large concentration of weight on small area of skid, as shown in Figure 5

for load on this area, use

$$\text{wt of 1 tank} = 80^k$$

$$1/2 \text{ pan wt} = 6/2 = 3^k$$

$$1/2 \text{ skid wt} = 7.7/2 = 3.9^k$$

$$1/2 \text{ shield wt} = 8.6/2 = 4.3^k$$

$$\frac{91.2^k}{\text{say } 100^k}$$

$$\text{area of skid} = \frac{8}{12} [3(10' + 7')] = 34 \text{ ft}^2$$

$$\text{soil brg pressure} = q_b = \frac{100}{34} = 2.94 \text{ ksf}$$

Soil Bearing Capacity Ref. II p. 461 & 472

$$\text{for gravel, } N_{q1} = 33.3 \neq N_{\gamma1} = 48.0$$

$$\text{for silt, } N_{q2} = 14.7 \neq N_{\gamma2} = 16.7$$

$$\frac{\gamma_2 N_{\gamma_2}}{\gamma_1 N_{\gamma_1}} = \frac{100(16.7)}{125(48.0)} = 0.278 \quad \therefore K_s = 3.5 \text{ from Fig 10.22}$$

let $B = 7'$, $L = 10'$ $\hat{=} D_f = 0'$; try $H = 1.75'$

$$\begin{aligned} q_{u(b)} &= \gamma_1 (D_f + H) N_{q(2)} + \frac{1}{2} \left[1 - 0.4 \left(\frac{B}{L} \right) \right] \gamma_2 B N_{\gamma(2)} \\ &= 125(0 + 1.75)(14.7) + \frac{1}{2} \left[1 - 0.4 \left(\frac{7}{10} \right) \right] (100)(7)(16.7) \\ &= 7424 \text{ psf} \end{aligned}$$

shape factor $\lambda'_s = 1$

$$\begin{aligned} q_u &= q_{u(b)} + \left(1 + \frac{B}{L} \right) \gamma_1 H^2 \left(1 + \frac{2D_f}{H} \right) \left(\frac{K_s \tan \phi_1}{B} \right) \lambda'_s - \gamma_1 H \leq q_{u(t)} \\ &= 7424 + \left(1 + \frac{7}{10} \right) (125)(1.75)^2 \left(1 + 0 \right) \left(\frac{3.5 \tan 35^\circ}{7} \right) (1) - 125(1.75) \\ &= 7433 \text{ psf} \end{aligned}$$

$$\begin{aligned} q_{u(t)} &= \gamma_1 D_f N_{q(1)} + \frac{1}{2} \left[1 - 0.4 \frac{B}{L} \right] \gamma_1 B N_{\gamma(1)} \\ &= 125(0)(33.3) + \frac{1}{2} \left[1 - 0.4 \left(\frac{7}{10} \right) \right] (125)(7)(48.0) \\ &= 15120 \text{ psf} \end{aligned}$$

ult. bearing capacity = $q_u = 7433 \text{ psf}$

allowable bearing capacity = $q_a = \frac{q_u}{SF}$

for the given situation, $SF = 2.5$ seems appropriate to ensure sufficient gravel fill

$$q_a = 7433/2.5 = 2970 \text{ psf}$$

Since $q_b \approx q_a$, then $H=3'$ of gravel fill is OK

use min. of 1'-9" pit run gravel fill over existing soil
for support of skid & tanks

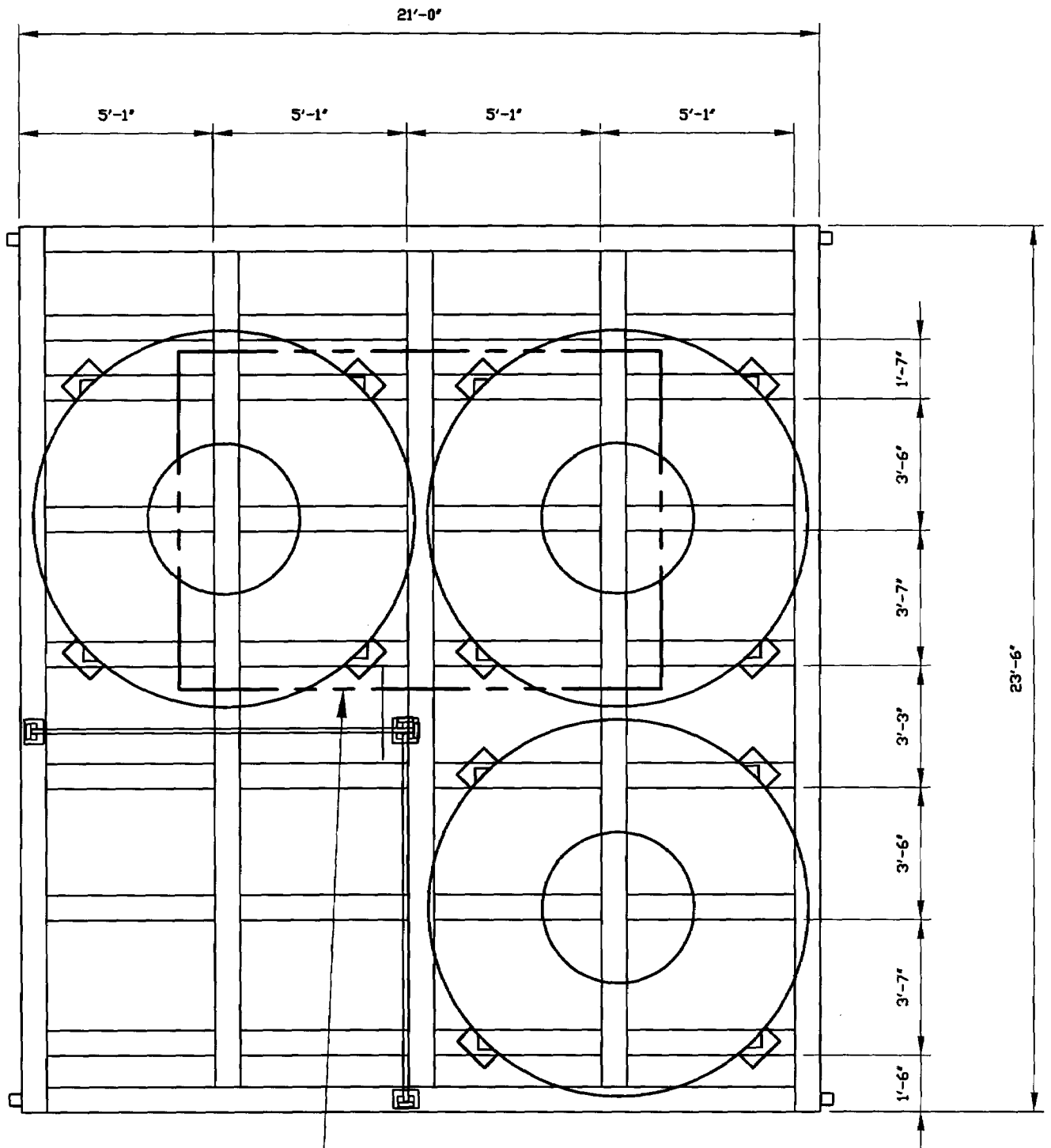

AREA OF SKID WITH
GREATEST LOAD
7' x 10'

FIGURE 5
TANK SUPPORT FRAME

where q_c , q_u , and q_r are the contributions of cohesion, surcharge, and unit weight of soil, respectively
 Reissner (1924) has expressed q_u as

$$q_u = qN_q \tag{10.31}$$

where

$$N_q = e^{\pi \tan \phi} \tan^2 \left(45 + \frac{\phi}{2} \right) \tag{10.32}$$

Prandtl (1921) has shown that

$$q_c = cN_c \tag{10.33}$$

where

$$N_c = (N_q - 1) \tan \phi \tag{10.34}$$

Eq. (10.32)

Caquot and Kerisel (1953) have expressed q_r as

$$q_r = \frac{1}{2} B \gamma N_\gamma \tag{10.35}$$

The numerical values given by Caquot and Kerisel can be approximated (Vesic, 1973) as

$$N_\gamma = 2(N_q + 1) \tan \phi \tag{10.36}$$

Eq. (10.32)

Combining Eqs. (10.30), (10.31), (10.33), and (10.35) we obtain

$$q_u = cN_c + qN_q + \frac{1}{2} \gamma B N_\gamma \tag{10.37}$$

This is in the same general form as given by Terzaghi [Eq. (10.9)]. However, the values of the bearing capacity factors are not the same. The values of N_q , N_c , and N_γ , defined by Eqs. (10.32), (10.34), and (10.36), are given in Table 10.1, but, for all practical purposes, Terzaghi's bearing capacity factors will yield good results. Differences in bearing capacity factors are usually minor as compared to the unknown soil parameters.

EDF-5017

96/138

(Ref. 11)

Table 10.1 Bearing Capacity Factors* [Eqs. (10.32), (10.34), and (10.36)]

ϕ (1)	N_c (2)	N_q (3)	N_γ (4)	N_c/N_c (5)	$\tan \phi$ (6)
0	5.14	1.00	0.00	0.20	0.00
1	5.38	1.09	0.07	0.20	0.02
2	5.63	1.20	0.15	0.21	0.03
3	5.90	1.31	0.24	0.22	0.05
4	6.19	1.43	0.34	0.23	0.07
5	6.49	1.57	0.45	0.24	0.09
6	6.81	1.72	0.57	0.25	0.11
7	7.16	1.88	0.71	0.26	0.12
8	7.53	2.06	0.86	0.27	0.14
9	7.92	2.25	1.03	0.28	0.16
10	8.35	2.47	1.22	0.30	0.18
11	8.80	2.71	1.44	0.31	0.19
12	9.28	2.97	1.69	0.32	0.21
13	9.81	3.26	1.97	0.33	0.23
14	10.37	3.59	2.29	0.35	0.25
15	10.96	3.94	2.65	0.36	0.27
16	11.63	4.34	3.06	0.37	0.29
17	12.34	4.77	3.53	0.39	0.31
18	13.10	5.26	4.07	0.40	0.32
19	13.93	5.80	4.68	0.42	0.34
20	14.83	6.40	5.39	0.43	0.36
21	15.82	7.07	6.20	0.45	0.38
22	16.88	7.82	7.13	0.46	0.40
23	18.05	8.66	8.20	0.48	0.42
24	19.32	9.60	9.44	0.50	0.45
25	20.72	10.66	10.88	0.51	0.47
26	22.25	11.85	12.54	0.53	0.49
27	23.94	13.20	14.47	0.55	0.51
28	25.80	14.72	16.72	0.57	0.53
29	27.86	16.44	19.34	0.59	0.55
30	30.14	18.40	22.40	0.61	0.58
31	32.67	20.63	25.99	0.63	0.60
32	35.49	23.18	30.22	0.65	0.62
33	38.64	26.09	35.19	0.68	0.65
34	42.16	29.44	41.06	0.70	0.67
35	46.12	33.30	48.03	0.72	0.70
36	50.59	37.75	56.31	0.75	0.73
37	55.63	42.92	66.19	0.77	0.75
38	61.35	48.93	78.03	0.80	0.78
39	67.87	55.96	92.25	0.82	0.81
40	75.31	64.20	109.41	0.85	0.84
41	83.86	73.90	130.22	0.88	0.87
42	93.71	85.38	155.55	0.91	0.90
43	105.11	99.02	186.54	0.94	0.93
44	118.37	115.31	224.64	0.97	0.97
45	133.88	134.88	271.76	1.01	1.00
46	152.10	158.51	330.35	1.04	1.04
47	173.64	187.21	403.67	1.08	1.07
48	199.26	222.31	496.01	1.12	1.11
49	229.93	265.51	613.16	1.15	1.15
50	266.89	319.07	762.89	1.20	1.19

*After Vesic (1973)

(Ref. 11)

into consideration. Studies regarding the ultimate bearing capacity of foundations on layered soils are very limited at this time. Some of these cases will be briefly discussed below.

*** Foundations on Layered Sand—Dense over Loose**

A simple theory for determining the ultimate bearing capacity of a foundation that rests on a layer of dense sand underlain by loose sand has been proposed by Meyerhof and Hanna (1978). The basic principle of this theory can be explained with the aid of Figure 10.21, which is for a strip foundation. When the depth of the top dense sand layer is relatively thick, as shown by the right-hand half of Figure 10.21, the failure surface in soil under the foundation will be fully located inside the dense sand. For this case

$$q_u = q_{u(0)} = \gamma_1 D_f N_{q(1)} + \frac{1}{2} \gamma_1 B N_{\gamma(1)} \quad (10.50)$$

(for strip foundations)

$$q_u = q_{u(0)} = \gamma_1 D_f N_{q(1)} + 0.3 \gamma_1 B N_{\gamma(1)} \quad (10.51)$$

(for circular or square foundations)

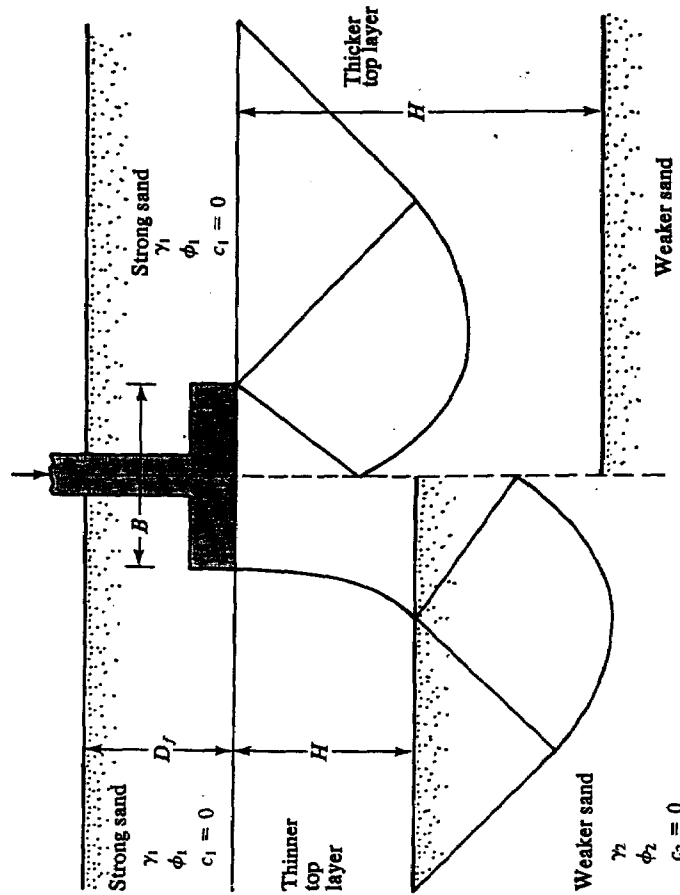

Figure 10.21 Bearing capacity in layered sand—strong sand underlain by weak sand

and

$$q_u = q_{u(0)} = \gamma_1 D_f N_{q(1)} + \frac{1}{2} \left[1 - 0.4 \left(\frac{B}{L} \right) \right] \gamma_1 B N_{\gamma(1)} \quad (10.52)$$

(for rectangular foundations)

where γ_1 = unit weight of top layer (dense sand in this case)
 $N_{q(1)}$ and $N_{\gamma(1)}$ = bearing capacity factors with reference to the soil friction angle, ϕ_1 (Table 10.1)

Note that Eqs. (10.50), (10.51), and (10.52) are similar to Eq. (10.38). However, the depth factors have not been incorporated; they can be assumed to be somewhat conservative.

If the thickness of the dense sand layer under the foundation H is relatively small, the failure in soil would take place by *punching* in the dense sand layer followed by a general shear failure in the bottom (or weaker) sand layer, as shown in the left-hand side of Figure 10.21. For such a case, the ultimate bearing capacity for the foundation can be given as

$$q_u = q_{u(0)} + \gamma_1 H^2 \left(1 + \frac{2D_f}{H} \right) K_s \frac{\tan \phi_1}{B} - \gamma_1 H \leq q_{u(0)} \quad (10.53)$$

(for strip foundations) [Eq. (10.50)]

$$q_u = q_{u(0)} + 2\gamma_1 H^2 \left(1 + \frac{2D_f}{H} \right) \left(\frac{K_s \tan \phi_1}{B} \right) \lambda'_s - \gamma_1 H \leq q_{u(0)} \quad (10.54)$$

(for square or circular foundations) [Eq. (10.51)]

and

$$q_u = q_{u(0)} + \left(1 + \frac{B}{L} \right) \gamma_1 H^2 \left(1 + \frac{2D_f}{H} \right) \left(\frac{K_s \tan \phi_1}{B} \right) \lambda'_s - \gamma_1 H \leq q_{u(0)} \quad (10.55)$$

(for rectangular foundations) [Eq. (10.52)]

where K_s = punching shear coefficient
 λ'_s = shape factor
 $q_{u(0)}$ = ultimate bearing capacity of the bottom soil layer

EDF-5017
 97/138

(Ref. 11)

The value of the shape factor λ_f can be taken to be approximately 1. The punching shear coefficient

$$K_s = f(\gamma_1, \gamma_2, N_{q(1)}, N_{q(2)}) \quad (10.56)$$

where γ_2 = unit weight of the lower layer of sand

$N_{q(2)}$ = bearing capacity factor for the soil friction angle, ϕ_2

The variation of K_s is shown in Figure 10.22. The term $q_{w(\phi)}$ in Eqs. (10.53), (10.54), and (10.55) is given by the following relationships:

$$q_{w(\phi)} = \gamma_1(D_f + H)N_{q(2)} + \frac{1}{2} \gamma_2 BN_{q(2)} \quad (10.57)$$

(for strip foundations)

$$q_{w(\phi)} = \gamma_1(D_f + H)N_{q(2)} + 0.3\gamma_2 BN_{q(2)} \quad (10.58)$$

(for circular or square foundations)

$$q_{w(\phi)} = \gamma_1(D_f + H)N_{q(2)} + \frac{1}{2} \left[1 - 0.4 \left(\frac{B}{L} \right) \right] \gamma_2 BN_{q(2)} \quad (10.59)$$

(for rectangular foundations)

For a given layered soil, the variation of q_u with H/B will be as shown in Figure 10.23.

Foundations on Layered Sand—Loose over Dense

Figure 10.24 shows a strip foundation supported by a loose sand layer underlain by a dense sand layer. Depending on the magnitude of H/B , two types of failure surface can be observed in the soil supporting the foundation. They are as follows:

a. If the thickness of the loose sand layer under the foundation (H) is large compared to the width of the foundation (B), then the failure surface in the soil would be completely in the weaker soil layer (right half of Figure 10.24). For that case

$$q_u = q_{w(\phi)} = \gamma_1 D_f N_{q(1)} + \frac{1}{2} \gamma_1 BN_{q(1)} \quad (10.60)$$

(for strip foundations)

$$q_u = q_{w(\phi)} = \gamma_1 D_f N_{q(1)} + 0.3\gamma_1 BN_{q(1)} \quad (10.61)$$

(for circular and square foundations)

$$q_u = q_{w(\phi)} = \gamma_1 D_f N_{q(1)} + \frac{1}{2} \left[1 - 0.4 \left(\frac{B}{L} \right) \right] \gamma_1 BN_{q(1)} \quad (10.62)$$

(for rectangular foundations)

where γ_1 = unit weight of upper soil layer
 $N_{q(1)}$ and $N_{q(1)}$ = bearing capacity factors with respect to soil friction angle, ϕ_1

b. When the thickness H is relatively small with respect to the foundation width B , the failure surface in soil will pass through the top and the bottom soil layer. This is shown in the left-hand half of Figure 10.24. With this condition (Meyerhof and Hanna, 1978)

$$q_u = q_{w(\phi)} + (q_{w(\phi)} - q_{w(\phi)}) \left(1 - \frac{H}{H_f} \right)^2 \quad (10.63)$$

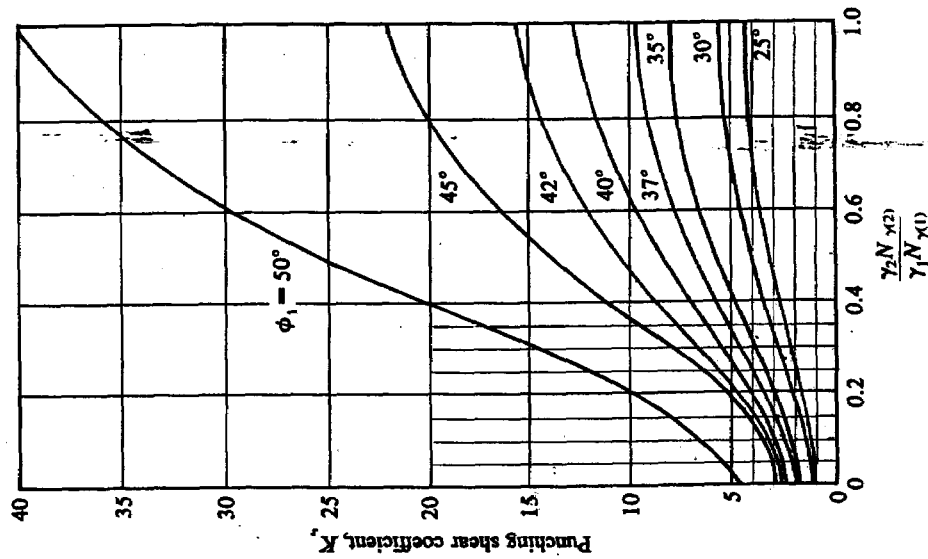

Figure 10.22 Variation of K_s with $(\gamma_2 N_{q(2)})/(\gamma_1 N_{q(1)})$

EDF-5017

98/138

Attachment 5
Tank Seismic Stability

TANK STABILITY

Although the PC is 0 for this design, tank stability will be evaluated for min. seismic activity, PC-1.

Using Microsoft Excel spreadsheet, pgs 101-103, the tank base shear force is determined using IBC methodology (Ref. 12) as required by AE Stds (Ref. 10).

$$\text{base shear force} = F = 0.162 \text{ k}$$

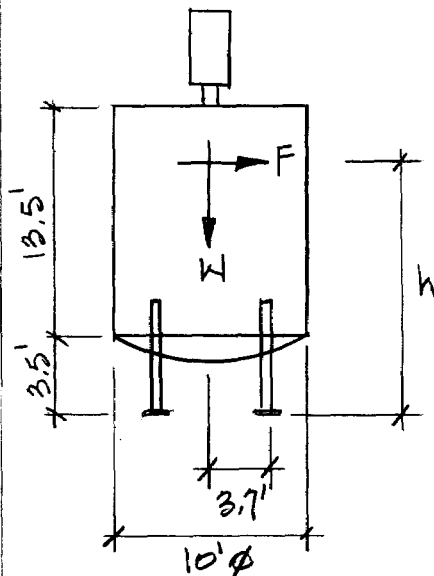

see Attachment 7
for Tank

conservatively assume $h = 10'$

$$M_{OT} = hF = 10(0.162) \text{ k} = 1.62 \text{ k}$$

$$M_R = 3.7 \text{ k}$$

$$SF = \frac{M_R}{M_{OT}} = \frac{3.7 \text{ k}}{1.62 \text{ k}} = 2.3$$

tank will not tip over due to seismic forces, with a safety factor of 2.3.

2003 IBC SEISMIC DESIGN LOADS

Project : V-Tank Consolidation Tanks at TAN
Structure: 8000 Gallon Vertical Tank on Support Legs
Designer : R. F. Lippert, P.E.
Remarks : PC-1 at TAN On Soil Layer > 10 Ft

NPH Performance Category, PC-1 or PC-2?

INEEL Facility (ANL,CFA,INTEC,NRF,RWMC,TAN,TRA,PBF,Idaho Falls):

Seismic Use Group ("I" for PC-1 or "III" for PC-2 per DOE-STD-1020):

Importance Factor (1.0 for PC-1 or 1.5 for PC-2 per DOE-STD-1020):

PC = 1 *
 Facility = TAN *
 SUG = I
 I = 1.0

Mapped Spectral Accelerations (IBC 1615.1 and DOE-ID AE Standards) :

Mapped Spectral Accelerations (g's)				
Facility	Latitude	Longitude	Short Periods S _S	1-Sec Period S ₁
TAN	43.847	112.707	0.405	0.148

Site Parameters (IBC 1615.1.2 and DOE-ID AE Standards) :

Soil layer depth below structure, d = 20.0 ft *

Site Class Based On Shear Wave Velocity				
Facility	On Rock	d < 10 ft	10 ft < d < 50 ft	50 ft < d < 80 ft
TAN	B	B	C	D

Site Class = C

Site Coefficient, F _a , for Short Periods			
Site Class	S _S = 0.25	S _S = 0.50	S _S = 0.75
C	1.2	1.2	1.1

F_a = 1.200

Site Coefficient, F _v , for 1-Second Period			
Site Class	S ₁ = 0.1	S ₁ = 0.2	S ₁ = 0.3
C	1.7	1.6	1.5

F_v = 1.652

Maximum Considered Earthquake Spectral Response Acceleration (IBC 1615.1.2) :

for short periods, S_{MS} = 0.486 g's
 for 1-sec period, S_{M1} = 0.244 g's

Design Spectral Response Acceleration, 5% damped (IBC 1615.1.3) :

for short periods, S _{DS} =	0.324 g's
for 1-sec period, S _{D1} =	0.163 g's

Design Response Spectrum Curve (IBC 1615.1.4) :

lowest period at peak acceleration, $T_0 =$ 0.101 seconds
 greatest period at peak acceleration, $T_s =$ 0.503 seconds

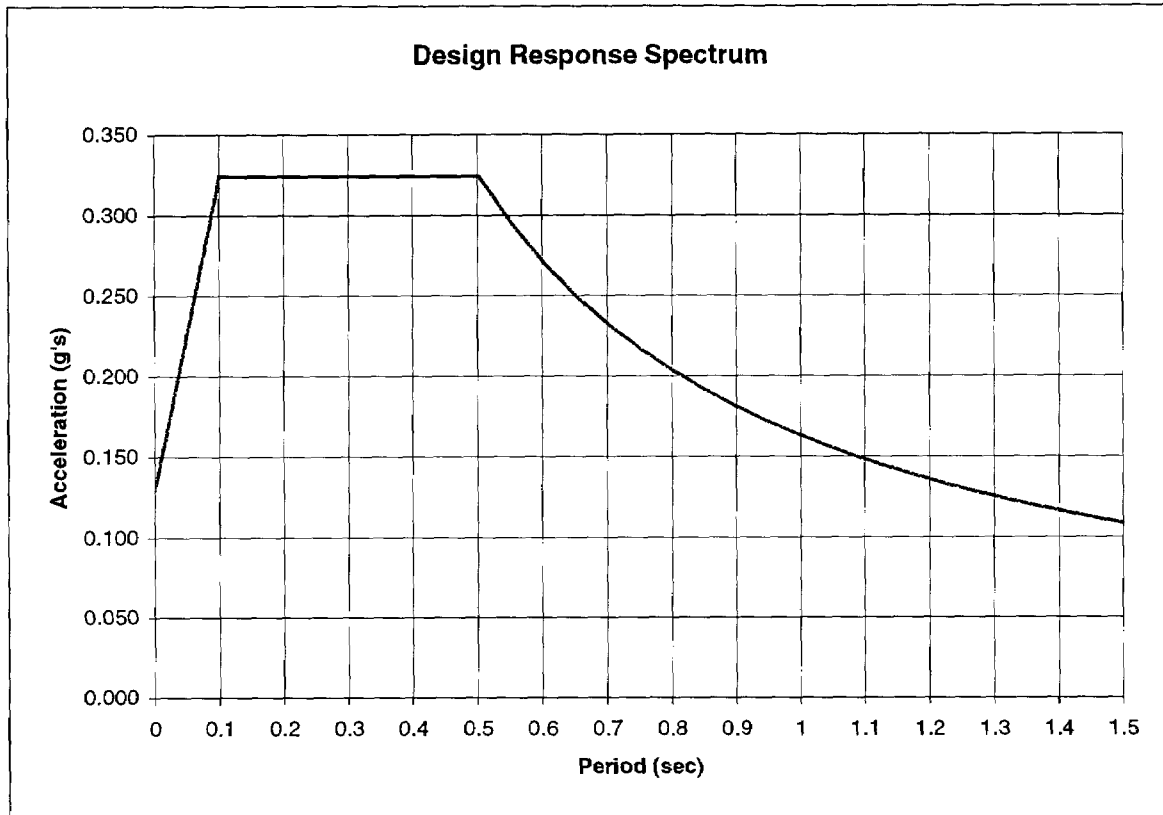

Seismic Design Category Determination (IBC 1616.3) :

Spectral Response Acceleration	Seismic Use Group	Seismic Design Category
Value of S_{DS} $0.167g < SDS < 0.33g$	I	B
Value of S_{D1} $0.133g < SD1 < 0.20g$		C

Seismic Design Category = C

Non-Building Structure -- Equivalent Lateral Force (IBC 1622 & ASCE 9.14)

Base Shear Force (ASCE Eq 9.5.5.2-1) : $V = C_s \cdot W$ (W = structure operating weight)

Base Shear Force for Rigid Structure, $T < 0.06$ sec (ASCE Eq 9.14.5.2) : $V = 0.3 \cdot S_{DS} \cdot W \cdot I$

seismic response coefficient (ASCE Eq 9.5.5.2.1-1) : $C_s = S_{DS} / (R/I_E)$

C_s need not exceed (ASCE Eq 9.5.5.2.1-2) : $S_{D1} / (R/I_E) / T$

C_s shall not be taken less than (ASCE Eq 9.14.5.1-1) : $0.014 \cdot S_{DS} \cdot I$

bldg fund. period, T, taken as the approx. period (ASCE Eq 9.5.5.3.2-1) : $T_a = C_T \cdot h_n^x$

importance factor, I = 1.0

height of structure to highest level, $h_n = 17.0$ ft *

response mod. coefficient (from ASCE Table 9.14.5.1.1), R = 2.0 *

structure period coeff. (ASCE Table 9.5.5.3.2: 0.035, 0.030 or 0.020), $C_T = 0.020$ *

building period exponent (ASCE Table 9.5.5.3.2: 0.8, 0.9, 0.75), x = 0.75

$T_a = 0.167$ sec

$C_s = 0.162$

maximum $C_s = 0.487$

minimum $C_s = 0.045$

force for rigid structure (if $T < 0.06$ sec), V = 0.097 W

Structure Base Shear Force, V =	0.162 W
---------------------------------	----------------

Attachment 6
V-Tank Mockup Platform Analysis

V-TANK MOCKUP PLATFORM

This attachment presents an analysis of the platform designed by Brian Raivo. The platform will be used for operator access in a mockup for the cleaning of the V-Tanks. The intent of the design is to support 2 to 3 people. See attached sketches.

LOADS

will assume LL = 40 psf and concentrated load $P = 300$ lb

but need not consider them acting together

walking area will be metal grating, supported by HSS 6x3x3/16 beams; grating has max. span = 3 ft

1 x 3/16 grating, $w_g = 7.2$ psf

w_g on intermediate beam = $7.2(3) = 21.6$ plf

w_g on perimeter beam = $21.6 / 2 = 10.8$ plf

LL on intermediate beam = $40(3) = 120$ plf

LL on perimeter beam = $120 / 2 = 60$ plf

In addition to the gravity loads, a 250 lb horizontal force was considered in a couple of locations in an effort to account for worker movement on the platform

ANALYSIS

STAAD.pro (Ref. 5) is used to analyze the structure. See following pages for input & output.

Members are determined adequate if their failure ratio (actual stress to allowable stress) is less than 1.0. The following are the results of the analysis:

Columns & beams -- max. failure ratio = 0.368 in element 27 for Load Case 11

Brace -- max. failure ratio = 1.048 in element 53 for Load Case 11

The failure ratio for the Brace is due to its slenderness ratio exceeding 200. When evaluating the stress in the Brace, its maximum axial compressive stress = 0.25 kips / 1.94 sq in = 0.13 ksi; this is less than its allowable stress of 3.40 ksi (equation E2-2 of Ref 2), so it is adequate (see para. B7 of Ref 2).

Max. horizontal deflection at the top of the platform was calculated to be 0.23 in; this is considered small, so OK.

EDF-
5017
106/138

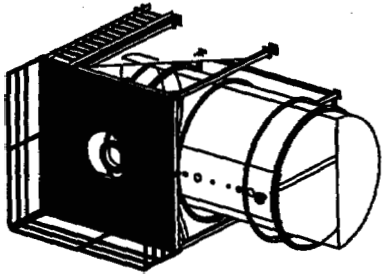

ISOMETRIC VIEW
(SHOWN FOR CLARITY)
SCALE: NONE

- NOTES:
1. REMOVE ALL BURRS AND CHAMF EDGES.
 2. ALL CORNERS AND FILLET RADIUS .03 UNLESS OTHERWISE NOTED.
 3. CLEARANCES PER STD-7922 LEVEL B.

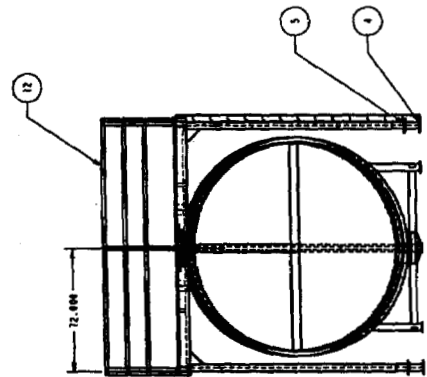
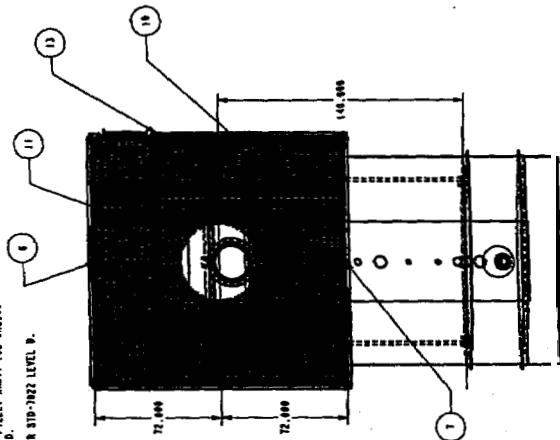

QTY	SYM	DESCRIPTION	UNIT	REF	DATE	BY	APP
1	15	SKETCH					
2	14	SKETCH					
1	13	SKETCH					
3	12	SKETCH					
2	11	SKETCH					
2	10	SKETCH					
1	9	SKETCH					
1	8	SKETCH					
1	7	SKETCH					
1	6	SKETCH					
3	5	SKETCH					
3	4	SKETCH					
3	3	SKETCH					
1	2	SKETCH					
1	1	SKETCH					

QTY	SYM	DESCRIPTION	UNIT	REF	DATE	BY	APP
1	15	SKETCH					
2	14	SKETCH					
1	13	SKETCH					
3	12	SKETCH					
2	11	SKETCH					
2	10	SKETCH					
1	9	SKETCH					
1	8	SKETCH					
1	7	SKETCH					
1	6	SKETCH					
3	5	SKETCH					
3	4	SKETCH					
3	3	SKETCH					
1	2	SKETCH					
1	1	SKETCH					

- 1 ASSEMBLY

EDF-5017
107/138

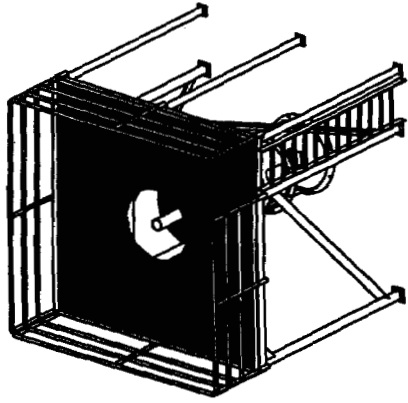

ISOMETRIC VIEW
(shown for clarity)
SCALE: NONE

- NOTES:
1. REMOVE ALL BURS AND SHARP CORNERS.
 2. ALL CORNER AND FILLET RADIUS .03 UNLESS OTHERWISE NOTED.
 3. CLEARANCES PER STD-1032 LEVEL B.

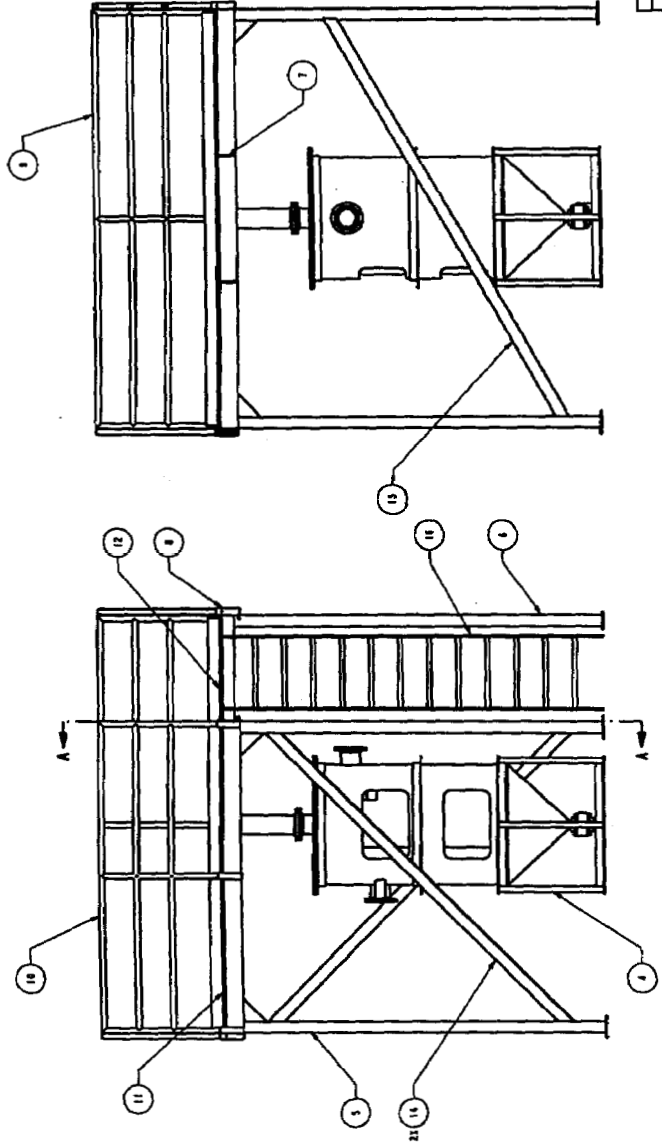

-1 ASSEMBLY

QTY	ITEM	DESCRIPTION	UNIT	REF. DIM.	ASSEMBLY	DATE	BY	CHKD
1	1	SKETCH						
1	2	SKETCH						
1	3	SKETCH						
1	4	SKETCH						
1	5	SKETCH						
1	6	SKETCH						
1	7	SKETCH						
1	8	SKETCH						
1	9	SKETCH						
1	10	SKETCH						
1	11	SKETCH						
1	12	SKETCH						
1	13	SKETCH						
1	14	SKETCH						
1	15	SKETCH						
1	16	SKETCH						
1	17	SKETCH						
1	18	SKETCH						

INEL www.inel.gov

TBD
V Tank Mockup Assembly

626285 1.0

1 OF 1

EDF-5017
108/138

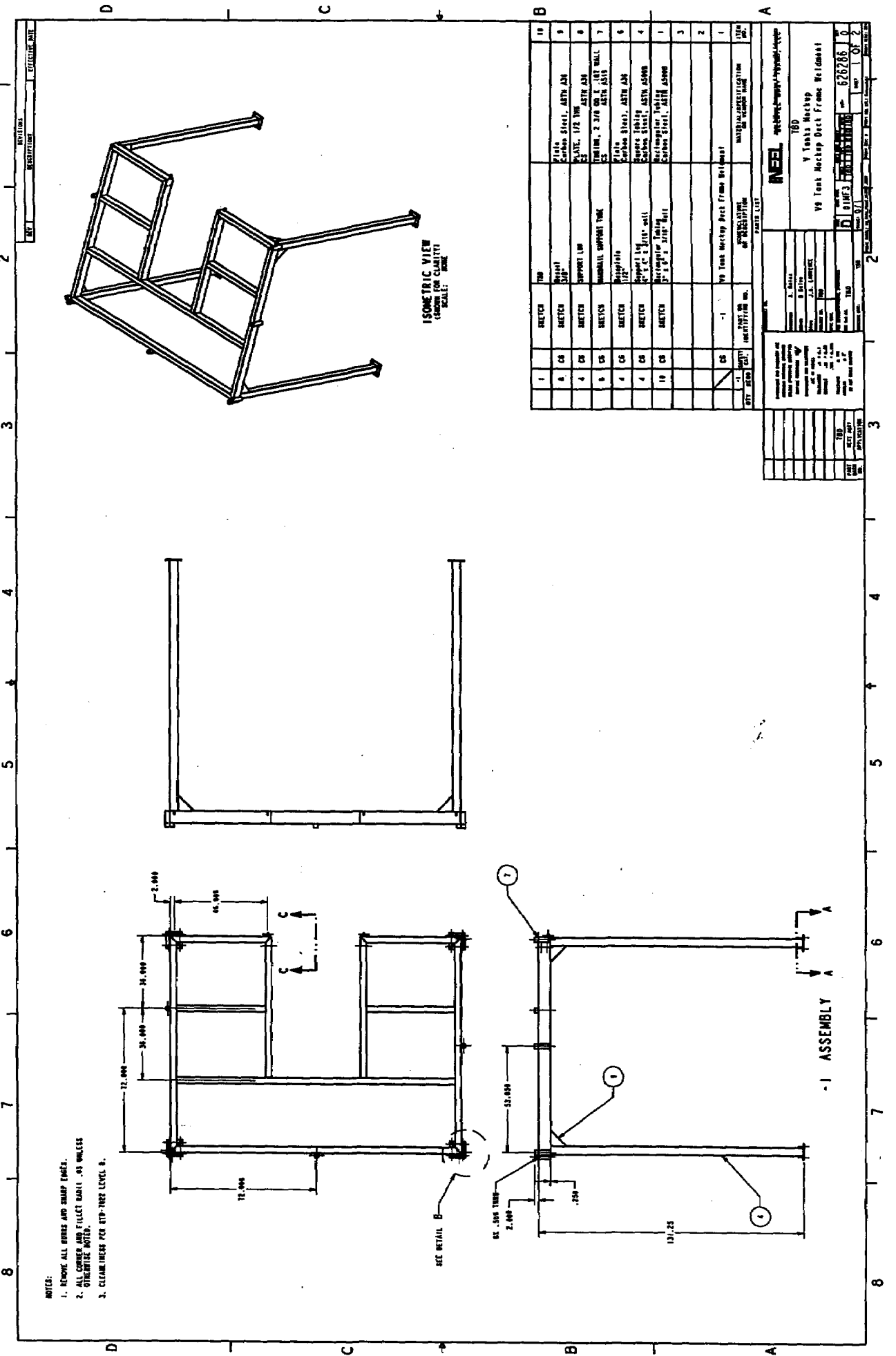

- NOTES:**
- 1. REMOVE ALL BERRS AND SHARP EDGES.
 - 2. ALL CORNER AND FILLET RADIUS AS UNLESS OTHERWISE NOTED.
 - 3. CLEARANCES FOR RTQ-1002 LEVEL 0.

ISOMETRIC VIEW
(NORMAL FOR CLARITY)
SCALE: NONE

-1 ASSEMBLY

REV	DATE	DESCRIPTION	BY	CHKD
1				
2				
3				
4				
5				
6				
7				
8				
9				
10				

REV	DATE	DESCRIPTION	BY	CHKD
1				
2				
3				
4				
5				
6				
7				
8				
9				
10				

REVISIONS			
DATE: 11/12/84			
DRAWN BY: J.A. LEMMON			
CHECKED BY: J.A. LEMMON			
DESIGNED BY: J.A. LEMMON			
MATERIALS SPECIFICATION: V TANK DECK FRAME WELDMENT			
SCALE: NONE			
JOB NO.: 108/138			
PROJECT NO.: 526786			
SHEET NO.: 1 OF 2			

EDF-
5017
109/138

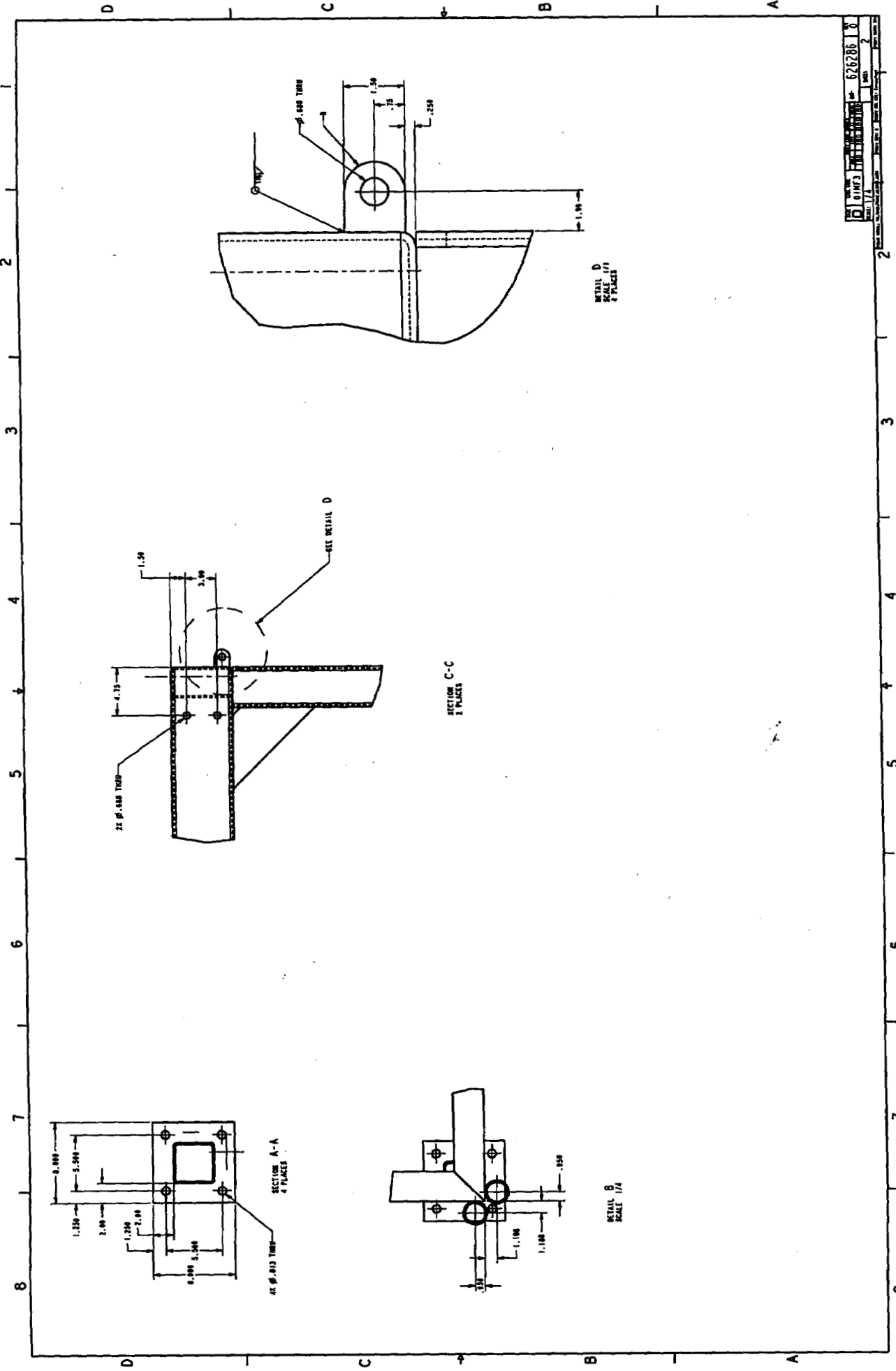

REV	DATE	BY	CHKD	APP'D
1				
2				

626286 10
1000
17A

EDF-5017
110/138

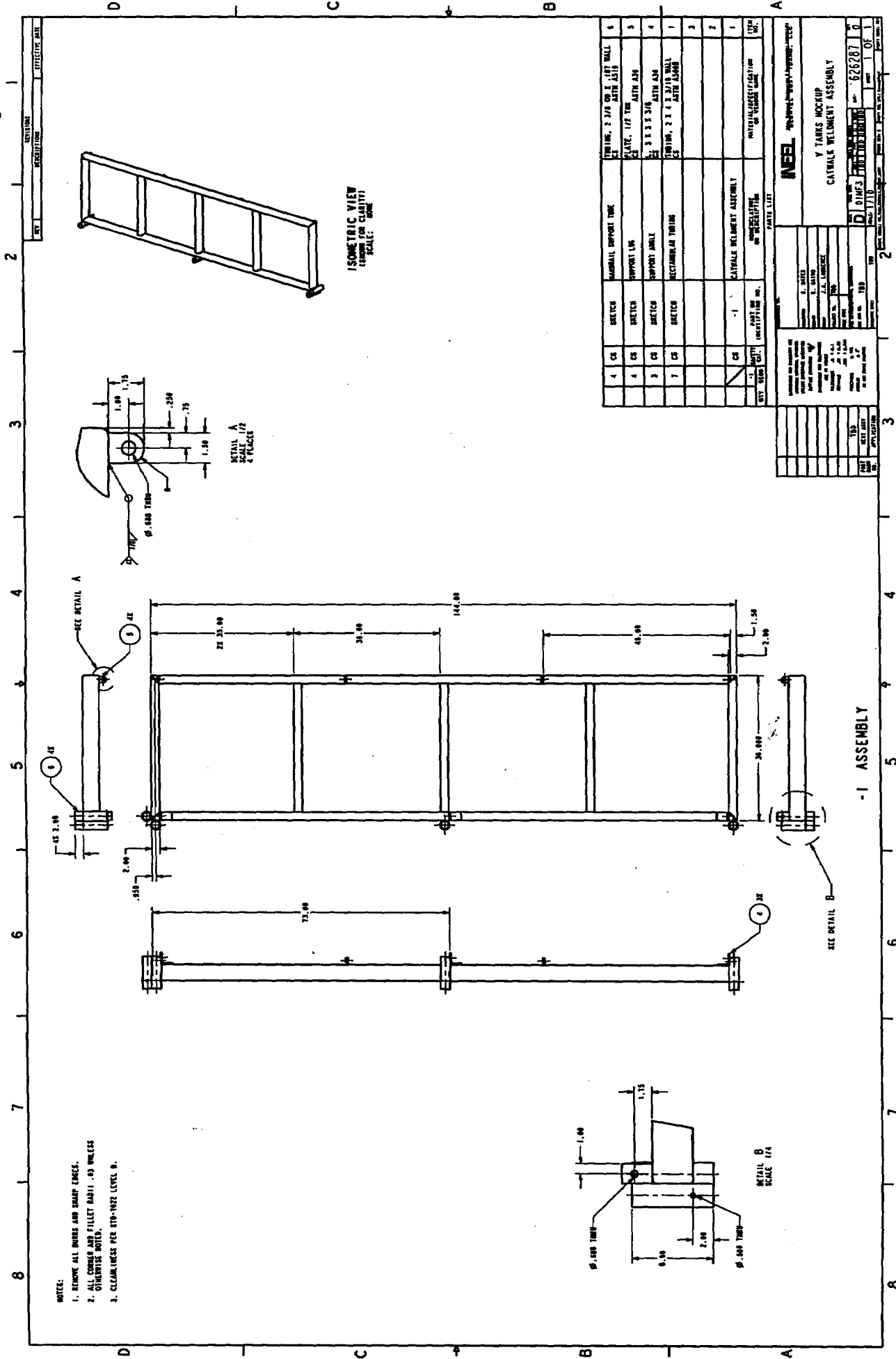

- NOTES:
1. REMOVE ALL BURS AND SHARP EDGES.
 2. ALL CORNER AND FILLET RADIUS .63 UNLESS OTHERWISE NOTED.
 3. CLEAN LINES PER STD-1052 LEVEL B.

QTY	UNIT	DESCRIPTION	MATERIAL IDENTIFICATION OR NUMBER	ITEM NO.
4	CS	BRETCR	FORMING, 2.5X4 COR 2.00 WALL WITH JOIN	6
4	CS	BRETCR	PLATE, 1/2 THK	5
3	CS	BRETCR	3 X 3 X 3/8 WITH JOIN	4
7	CS	BRETCR	FORMING, 2.5 X 4 X 3/8 WALL WITH JOIN	1
3	CS	BRETCR		3
2	CS	BRETCR		2
1	CS	BRETCR	CATWALK WELDMNT ASSEMBLY	1
1	CS	BRETCR	WELDMNT IDENTIFICATION	129

NEEL
Weldment Assembly - Support - C-100

V-TAKES MOCKUP
CATWALK WELDMNT ASSEMBLY

DATE	REV	APP/VAL	REV
10/20/03	1	100	1

DIMES
PART NO. 625207
REV. 1 OF 1

EDF-5017
111/138

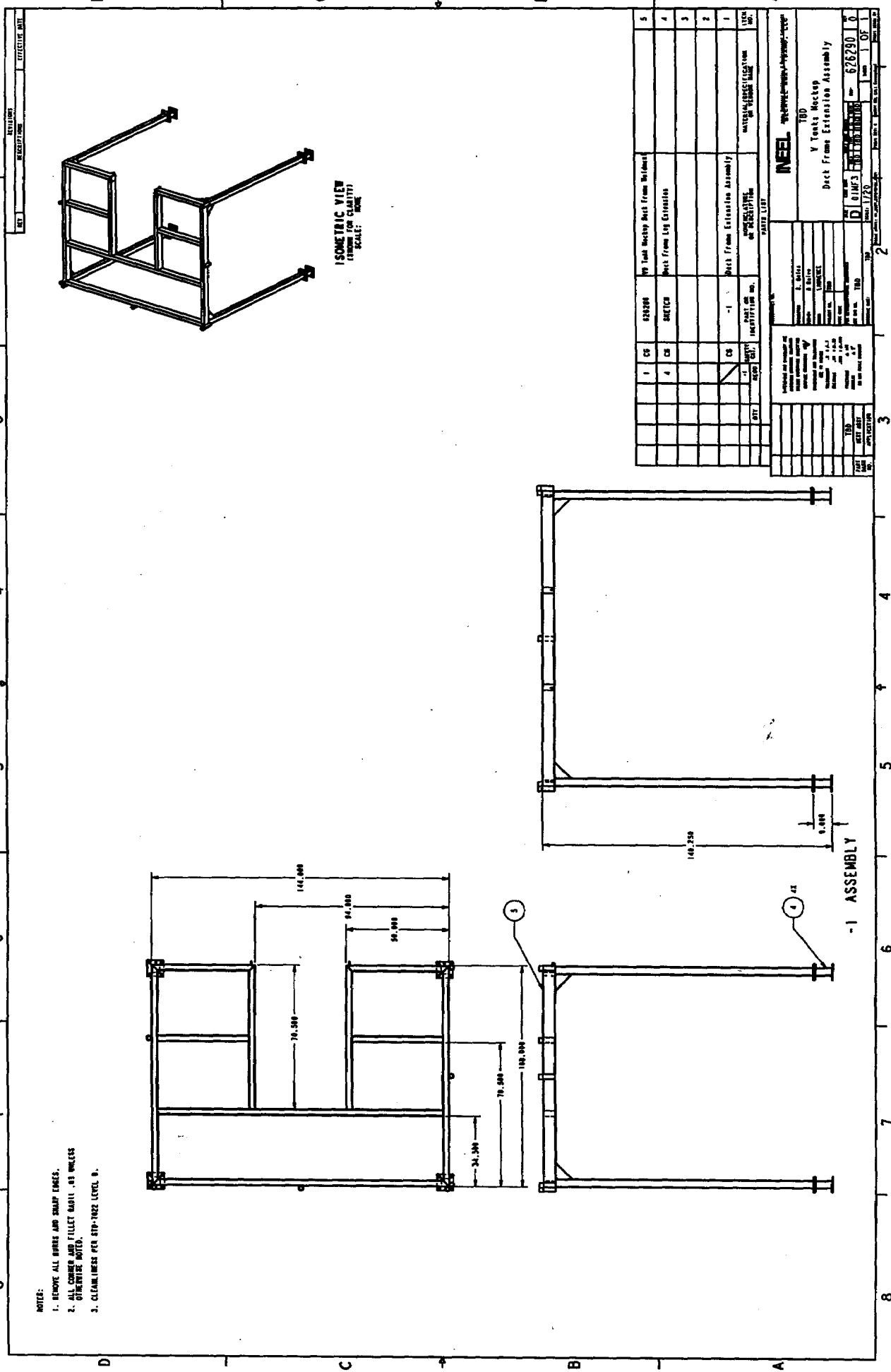

EDF-
5017
112/138

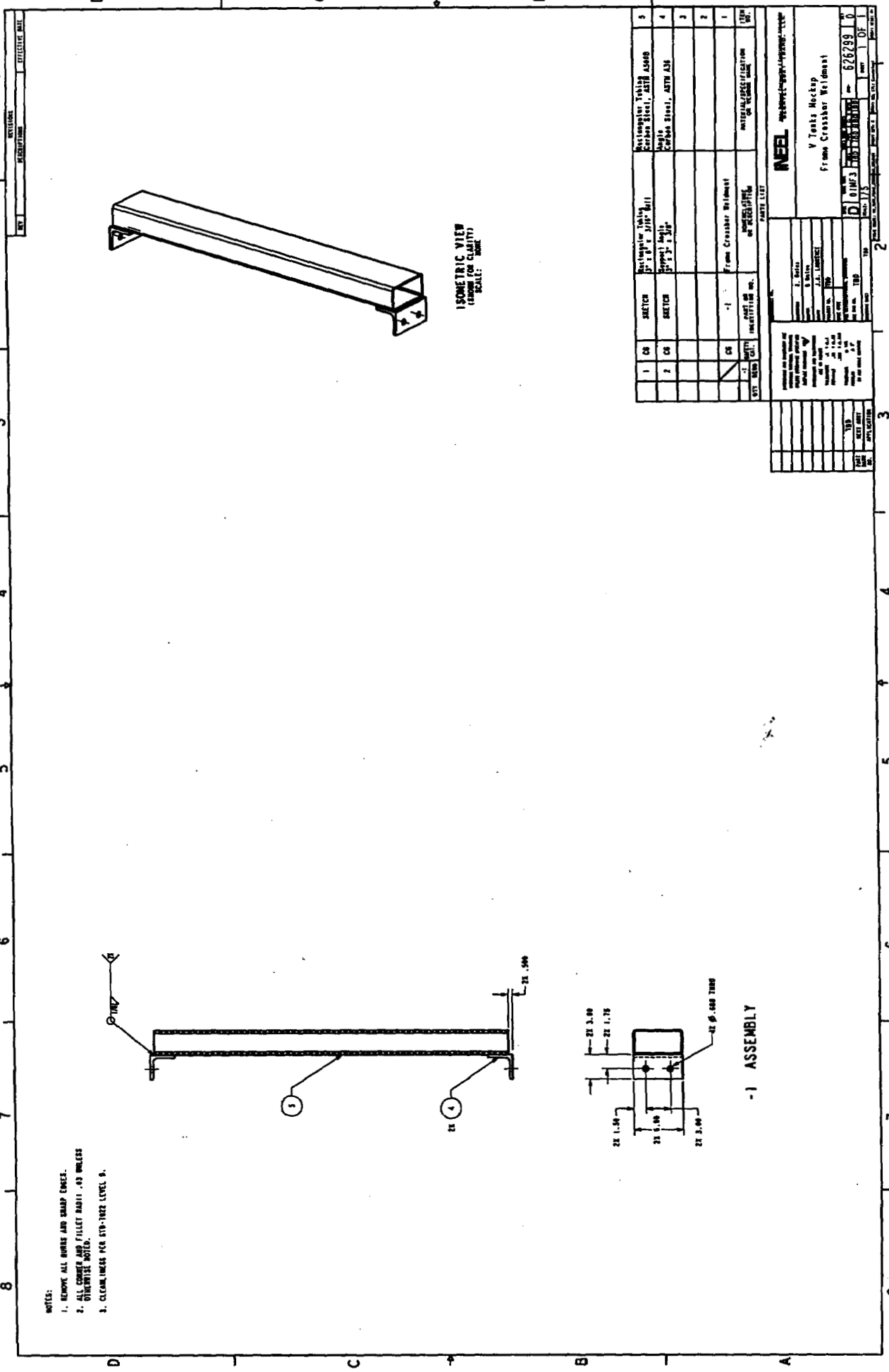

ISOMETRIC VIEW
(shown for clarity)
SCALE: NONE

- NOTES:
1. REMOVE ALL BURS AND SHARP EDGES.
 2. ALL CORNER AND FILLET RADIUS .40 UNLESS OTHERWISE NOTED.
 3. CLEANLINESS PER STD-1002 LEVEL B.

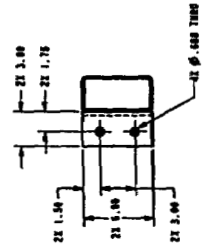

-1 ASSEMBLY

REV	DESCRIPTION	DATE	BY	CHKD
1	ISSUED FOR FABRICATION			

NO	QTY	DESCRIPTION	MATERIAL SPECIFICATION
1	1	SKETCH	FRAMING TUBING, 2" DIA. ALUMINUM
2	1	SKETCH	FRAMING TUBING, 2" DIA. ALUMINUM
3	1	SKETCH	FRAMING TUBING, 2" DIA. ALUMINUM
4	1	SKETCH	FRAMING TUBING, 2" DIA. ALUMINUM
5	1	SKETCH	FRAMING TUBING, 2" DIA. ALUMINUM

NEEL V Tank Hecker Frame Crossbar Weldment	
PART NO: 676299 REV: 01 DATE: 11/2/79	DRAWN BY: [Signature] CHECKED BY: [Signature]

EDF-5017
113/138

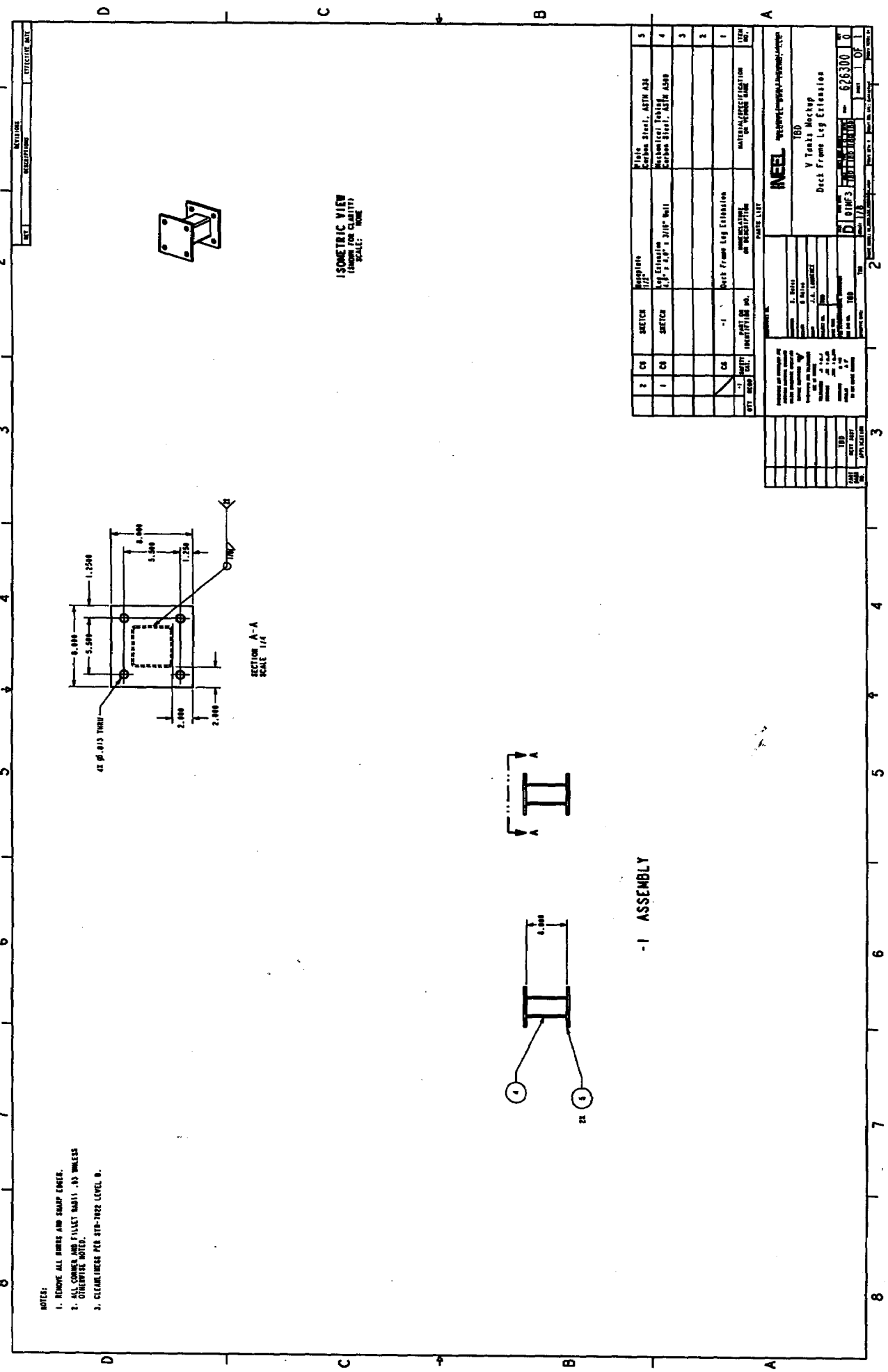

- NOTES:
1. REMOVE ALL DIMS AND SNAP DIMES.
 2. ALL CORNERS AND FILLET RADIUS .63 UNLESS OTHERWISE NOTED.
 3. CLEARANCES PER STEP-THRU LEVEL 0.

ISOMETRIC VIEW
(DRAWN FOR QUANTITY)
SCALE: NONE

SECTION A-A
SCALE 1/4

- 1 ASSEMBLY

QTY	DESCRIPTION	UNIT	AMOUNT	PERCENT	DATE	BY	CHKD	APP'N
2	2	CS	SHEET					
1	CS	SHEET	Leg Extension C.P. 2, C.P. 1 210R 0611					
1	CS	SHEET	Deck Frame Leg Extension					
1	CS	SHEET	ISOMETRIC VIEW					
1	CS	SHEET	SECTION A-A					
1	CS	SHEET	DETAIL					

1	CS	SHEET	DETAIL					
1	CS	SHEET	SECTION A-A					
1	CS	SHEET	ISOMETRIC VIEW					
1	CS	SHEET	Deck Frame Leg Extension					
1	CS	SHEET	Leg Extension C.P. 2, C.P. 1 210R 0611					
2	CS	SHEET	2					

1	CS	SHEET	DETAIL					
1	CS	SHEET	SECTION A-A					
1	CS	SHEET	ISOMETRIC VIEW					
1	CS	SHEET	Deck Frame Leg Extension					
1	CS	SHEET	Leg Extension C.P. 2, C.P. 1 210R 0611					
2	CS	SHEET	2					

INCEL INTERNATIONAL CONSULTANTS

180
V Jenks Hookup
Deck Frame Leg Extension

NO. 001	REV. 001	DATE 03/24/04	BY	CHKD	APP'N
001	001	03/24/04			

PROJECT NO. 026300
JOB NO. 026300
REV. 001

EDF-5017
11/4/138

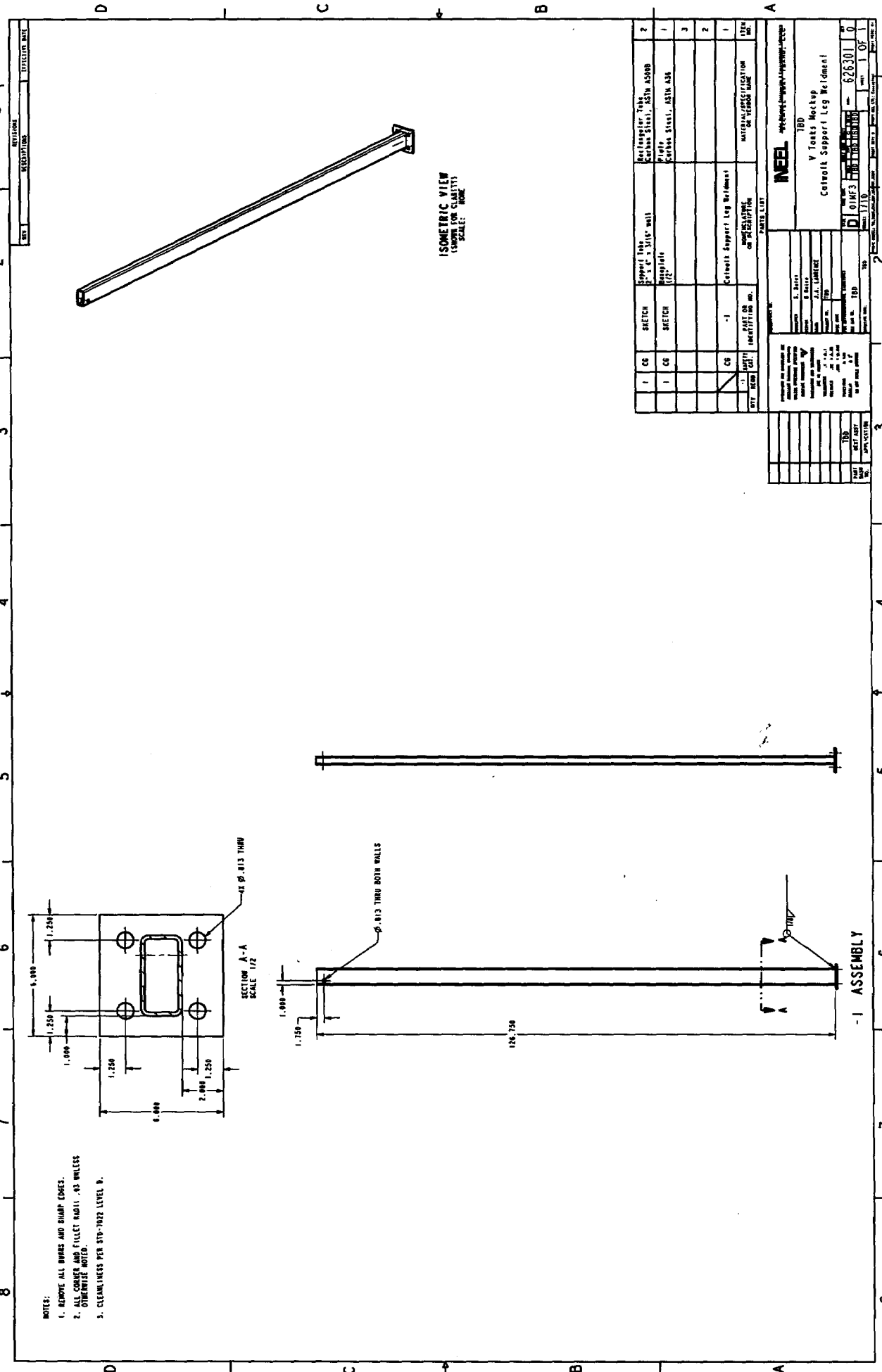

- NOTES:
1. REMOVE ALL BURRS AND SHARP EDGES.
 2. ALL CORNERS AND FILLET RADIUS .03 UNLESS OTHERWISE NOTED.
 3. CLEANLINESS PER STD-1022 LEVEL B.

SECTION A-A
SCALE 1/2

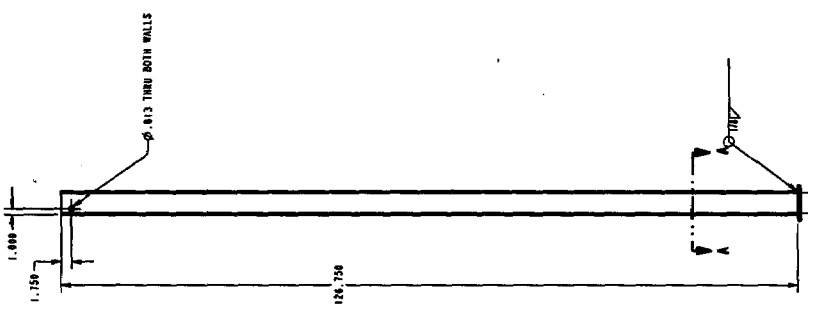

ISOMETRIC VIEW
(FOR CLARITY)
SCALE: NONE

QTY	DESCN	UNIT	INVENTORY NO.	DESCRIPTION OF REVISION	MATERIAL SPECIFICATION OR VENDOR NAME	DATE
1	CG	SKETCH		Support Leg Weldment	SAE 1018 Steel, ASTM A308	2
1	CG	SKETCH		Support Leg Weldment	SAE 1018 Steel, ASTM A308	1
					SAE 1018 Steel, ASTM A308	3
						2
1	CG			Cetrol Support Leg Weldment		1

INEL www.inel.com

Y-locks Neckup
Cetrol Support Leg Weldment

DATE: 11/04/138
DRAWN BY: J.J. LAMARCA
CHECKED BY: J.J. LAMARCA
APPROVED BY: J.J. LAMARCA

PROJECT NO: 626301
PART NO: 1 OF 1

```

STAAD SPACE V-TANK MOCKUP DECK FRAME
START JOB INFORMATION
JOB NAME V-TANK MOCKUP PLATFORM
JOB NO EDF-4727
ENGINEER NAME R LIPPERT
ENGINEER DATE 12-Mar-04
END JOB INFORMATION
INPUT WIDTH 79
UNIT INCHES POUND
JOINT COORDINATES
1 0 0 0; 2 144 0 0; 3 0 0 108; 4 144 0 108; 5
0 140 0; 6 144 140 0;
7 0 140 108; 8 144 140 108; 9 0 140 36; 10 0
140 72; 11 144 140 36;
12 144 140 72; 13 48 140 36; 14 96 140 36; 15
48 140 108; 16 96 140 108;
17 48 140 72; 18 96 140 72; 19 0 140 110.5; 20
144 140 110.5; 21 0 140 146.5;
22 144 140 146.5; 23 36 140 110.5; 24 72 140
110.5; 25 108 140 110.5;
26 36 140 146.5; 27 72 140 146.5; 28 108 140
146.5; 29 0 0 146.5;
30 144 0 146.5; 31 72 0 146.5; 32 48 140
110.5; 33 96 140 110.5;
34 0 21.4599 0; 35 0 21.4599 108; 36 0 127.737
108; 37 144 21.4599 108;
38 144 105.255 108; 39 144 127.737 0;
MEMBER INCIDENCES
1 1 34; 2 2 39; 3 3 35; 4 4 37; 5 5 6; 6 5 9;
7 6 11; 8 9 10; 9 10 7; 10 11 12;
11 12 8; 12 9 13; 13 13 14; 14 14 11; 15 13
17; 16 7 15; 17 14 18; 18 8 16;
19 17 15; 20 10 17; 21 18 16; 22 12 18; 23 15
16; 24 19 23; 25 21 26; 26 23 32;
27 24 33; 28 25 20; 29 19 21; 30 26 27; 31 23
25; 32 27 28; 33 24 27; 34 28 22;
35 25 28; 36 20 22; 37 29 21; 38 31 27; 39 30
22; 40 7 19; 41 32 24; 42 15 32;
43 33 25; 44 16 33; 45 8 20; 46 34 5; 47 35
36; 48 36 7; 49 37 38; 50 38 8;
51 39 6; 52 34 36; 53 35 38; 54 37 39;
START GROUP DEFINITION
MEMBER
_COL 1 TO 4 46 TO 51
_BM 5 TO 22
END GROUP DEFINITION
DEFINE MATERIAL START
ISOTROPIC STEEL
E 2.9e+007
POISSON 0.3
DENSITY 0.283
ALPHA 6.5e-006
DAMP 0.03
END DEFINE MATERIAL
CONSTANTS
BETA 90 MEMB 37 TO 39
BETA 315 MEMB 52 TO 54
MATERIAL STEEL MEMB 1 TO 54
MEMBER PROPERTY AMERICAN
1 TO 4 46 TO 51 TABLE ST TUB40403
5 TO 23 TABLE ST TUB60303
24 TO 39 41 43 TABLE ST TUB40203
MEMBER PROPERTY AMERICAN
40 42 44 -
45 PRIS AX 100 AY 100 AZ 100 IX 10000 IY 10000
IZ 10000 YD 1 ZD 1 YB 1 ZB 1
52 TO 54 TABLE ST L40404
MEMBER OFFSET
46 48 50 51 END 0 -3 0
37 TO 39 END 0 -1 0
24 TO 36 41 43 START 0 1 0
24 TO 36 41 43 END 0 1 0
1 END 0 -0.459854 0
46 START 0 -0.459854 0
3 END 0 -0.459854 0
47 START 0 -0.459854 0
47 END 0 -2.73723 0
48 START 0 -2.73723 0
4 END 0 -0.459854 0
49 START 0 -0.459854 0
49 END 0 -2.25547 0
50 START 0 -2.25547 0
2 END 0 -2.73723 0
51 START 0 -2.73723 0
MEMBER RELEASE
23 START MY MZ
23 37 TO 40 42 44 45 END MY MZ
52 START MY MZ
52 END MY MZ
53 START MY MZ
53 END MY MZ
54 START MY MZ
54 END MY MZ
SUPPORTS
1 TO 4 29 TO 31 PINNED
LOAD 1 DEAD LOAD
SELFWEIGHT Y -1
UNIT FEET POUND
MEMBER LOAD
12 TO 14 16 18 20 22 23 UNI GY -22
5 25 30 32 34 UNI GY -11
LOAD 2 UNIFORM LL
MEMBER LOAD
12 TO 14 16 18 20 22 23 UNI GY -120
5 25 30 32 34 UNI GY -60
UNIT INCHES POUND
LOAD 3 CONCEN LL1
MEMBER LOAD
13 CON GY -300
LOAD 4 CONCEN LL2
MEMBER LOAD
22 CON GY -300
LOAD 5 CONCEN LL3
MEMBER LOAD
20 CON GY -300
LOAD 6 CONCEN LL4
MEMBER LOAD
23 CON GY -300
LOAD 7 CONCEN LL5
MEMBER LOAD
33 CON GY -300
LOAD 8 LATLOAD1
JOINT LOAD
14 FX -250
LOAD 9 LATLOAD2
JOINT LOAD
27 FX -250
LOAD 10 LATLOAD3
JOINT LOAD
10 FZ -250
LOAD COMB 11 DL+ULL+LAT1
1 1.0 2 1.0 8 1.0
LOAD COMB 12 DL+ULL+LAT2
1 1.0 2 1.0 9 1.0
LOAD COMB 13 DL+ULL+LAT3
1 1.0 2 1.0 10 1.0
LOAD COMB 14 DL+LL1+LL2
1 1.0 3 1.0 4 1.0
LOAD COMB 15 DL+LL2+LL3
1 1.0 4 1.0 5 1.0
LOAD COMB 16 DL+LL2+LL4
1 1.0 4 1.0 6 1.0
LOAD COMB 17 DL+LL5
1 1.0 7 1.0
UNIT FEET POUND
PERFORM ANALYSIS PRINT ALL
CHANGE
LOAD LIST 1 11 TO 17
UNIT INCHES POUND
PARAMETER
CODE AISC
FYLD 46000 MEMB 1 TO 39 41 43 46 TO 51
UNT 36 MEMB 26 27 41 43
CHECK CODE MEMB 1 TO 39 41 43 46 TO 54
FINISH

```



Software licensed to INEEL

Job No EDF-5017	Sheet No 116 of 138	Rev
Part		
Ref		
By R LIPPERT	Date 12-Mar-04	Chd
Client	File MockupFrame.std	Date/Time 30-Jun-2004 16:16

Job Title **V-TANK MOCKUP PLATFORM**

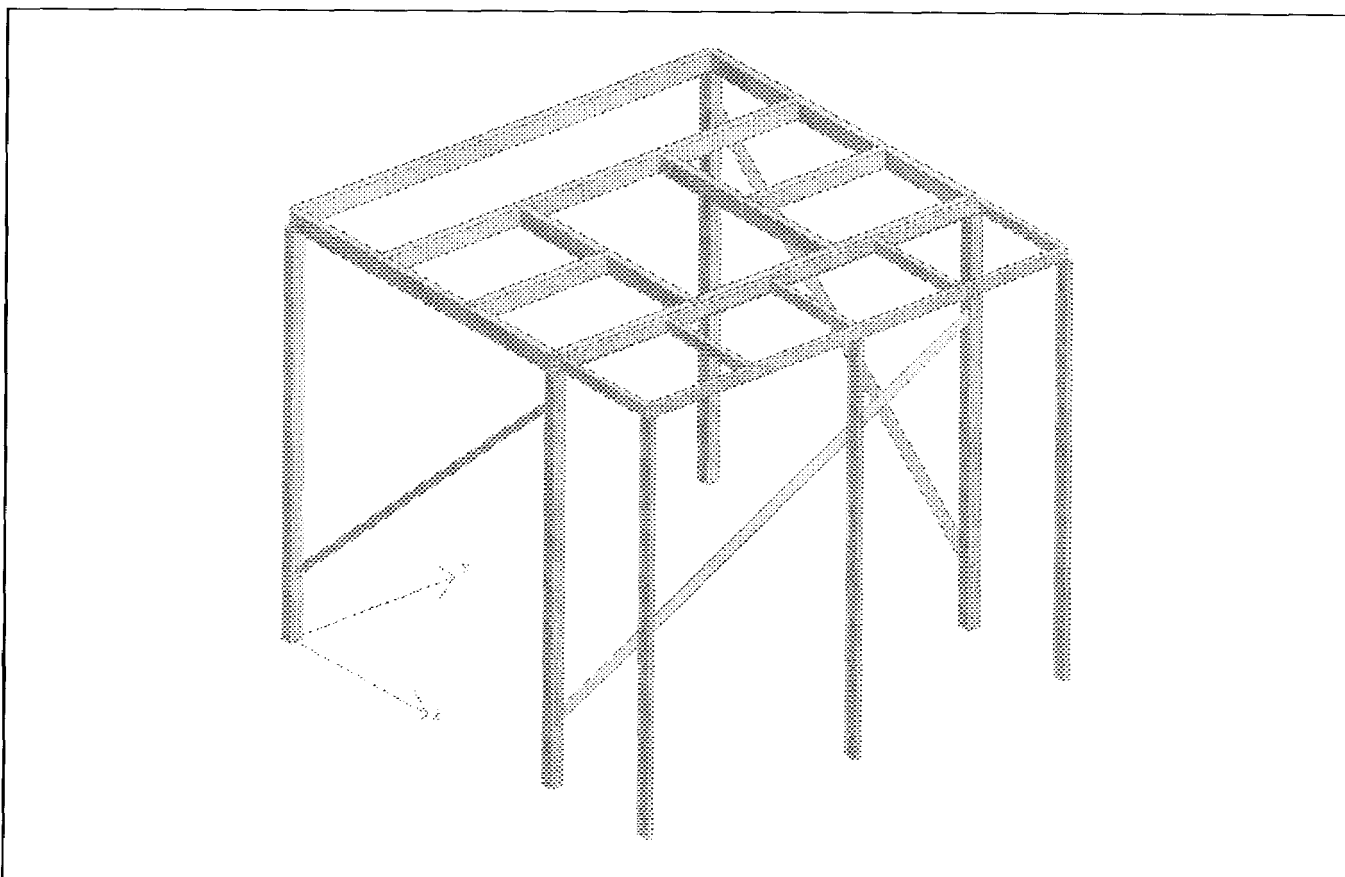

3D Rendered View



Software licensed to INEEL

Job No
EDF-5017

Sheet No
117 of 138

Rev

Job Title **V-TANK MOCKUP PLATFORM**

Part

Ref

By **R LIPPERT** Date **12-Mar-04** Chd

Client

File **MockupFrame.std**

Date/Time **30-Jun-2004 16:16**

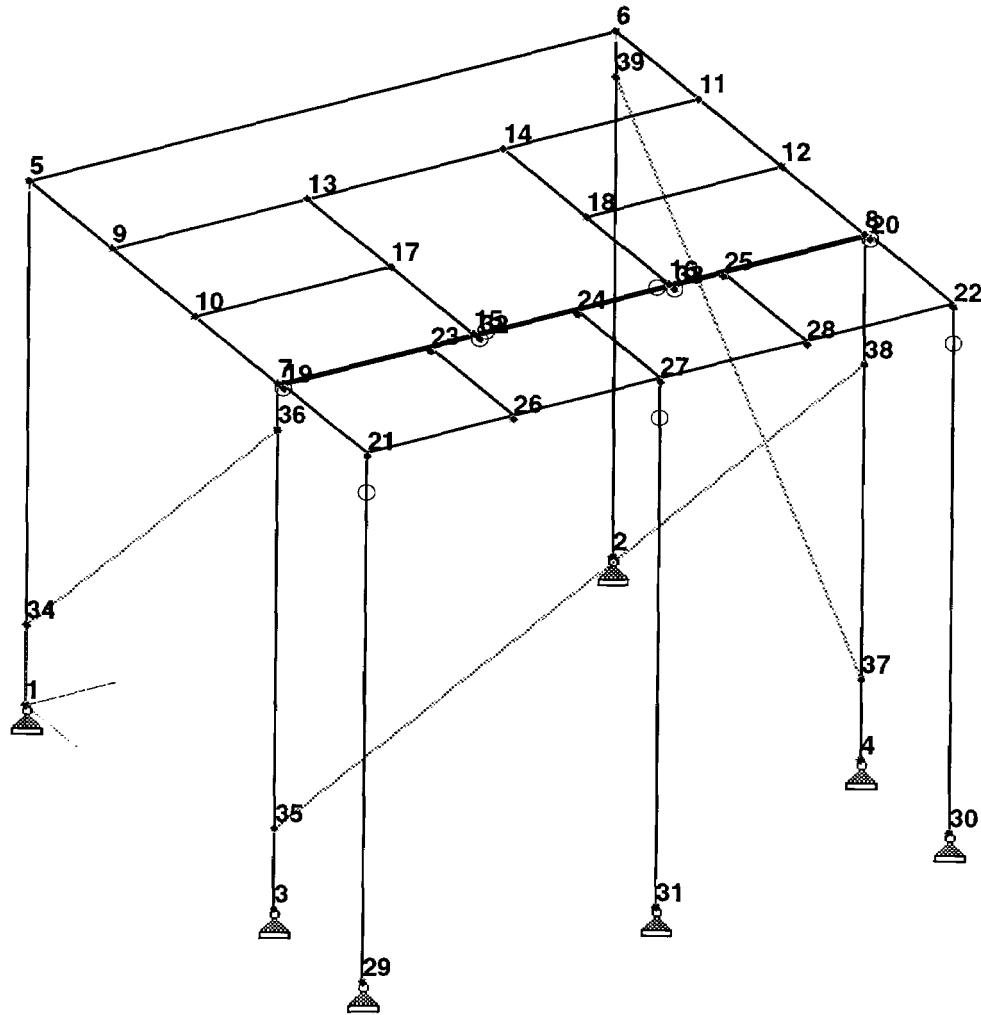

NODE NUMBERS



Software licensed to INEEL

Job No
EDF-5017

Sheet No
118 of 138

Rev

Job Title **V-TANK MOCKUP PLATFORM**

Part

Ref

By **R LIPPERT**

Date **12-Mar-04**

Chd

Client

File **MockupFrame.std**

Date/Time **30-Jun-2004 16:16**

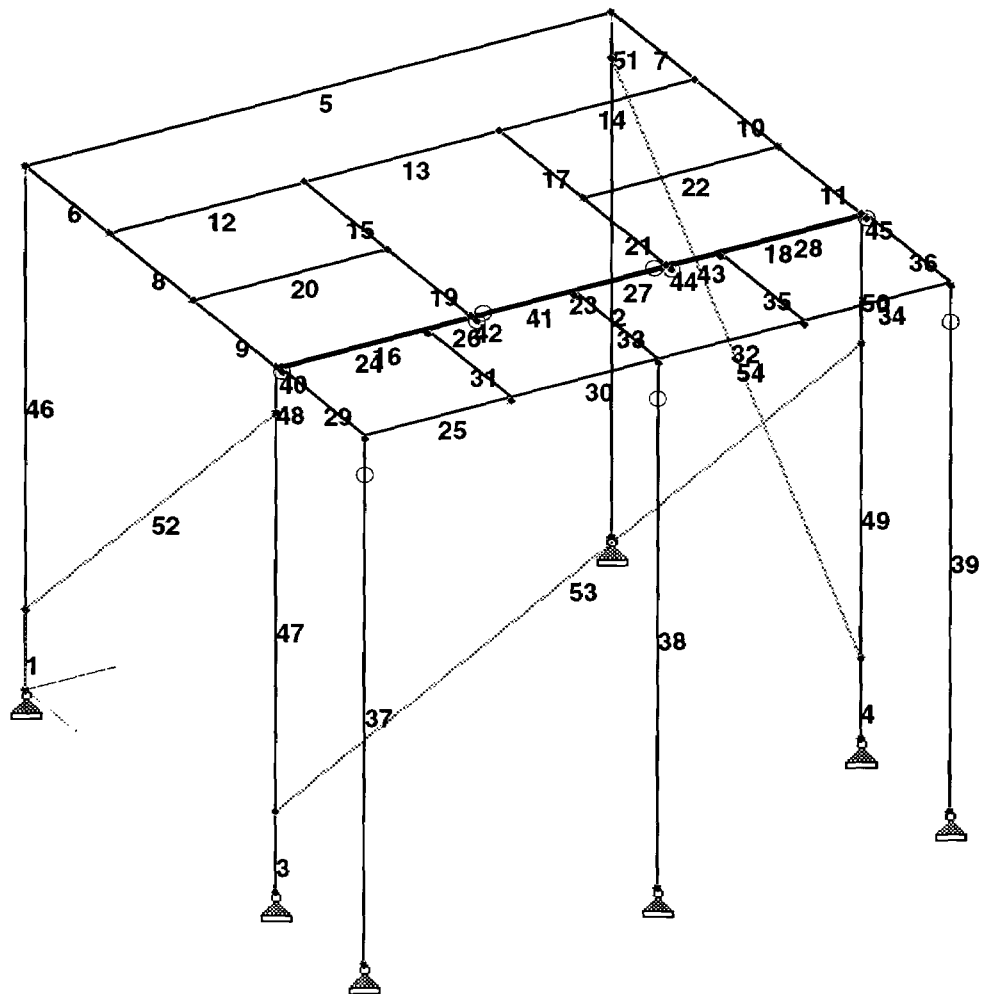

BEAM NUMBERS



Software licensed to INEEL

Job No EDF-5017	Sheet No 119 of 138	Rev
Part		
Ref		
By R LIPPERT	Date 12-Mar-04	Chd
Client	File MockupFrame.std	Date/Time 30-Jun-2004 16:16

Job Title **V-TANK MOCKUP PLATFORM**

Job Information

	Engineer	Checked	Approved
Name:	R LIPPERT		
Date:	12-Mar-04		

Structure Type | SPACE FRAME

Number of Nodes	39	Highest Node	39
Number of Elements	54	Highest Beam	54

Number of Basic Load Cases	10
Number of Combination Load Cases	7

Included in this printout are data for:

All	The Whole Structure
------------	---------------------

Included in this printout are results for load cases:

Type	L/C	Name
Primary	1	DEAD LOAD
Combination	11	DL+ULL+LAT1
Combination	12	DL+ULL+LAT2
Combination	13	DL+ULL+LAT3
Combination	14	DL+LL1+LL2
Combination	15	DL+LL2+LL3
Combination	16	DL+LL2+LL4
Combination	17	DL+LL5

Nodes

Node	X (in)	Y (in)	Z (in)
1	0.000	0.000	0.000
2	144.000	0.000	0.000
3	0.000	0.000	108.000
4	144.000	0.000	108.000
5	0.000	140.000	0.000
6	144.000	140.000	0.000
7	0.000	140.000	108.000
8	144.000	140.000	108.000
9	0.000	140.000	36.000
10	0.000	140.000	72.000
11	144.000	140.000	36.000
12	144.000	140.000	72.000
13	48.000	140.000	36.000
14	96.000	140.000	36.000
15	48.000	140.000	108.000
16	96.000	140.000	108.000



Software licensed to INEEL

Job No
EDF-5017

Sheet No
120 of 138

Rev

Part

Job Title **V-TANK MOCKUP PLATFORM**

Ref

By **R LIPPERT** Date **12-Mar-04** Chd

Client

File **MockupFrame.std** Date/Time **30-Jun-2004 16:16**

Nodes Cont...

Node	X (in)	Y (in)	Z (in)
17	48.000	140.000	72.000
18	96.000	140.000	72.000
19	0.000	140.000	110.500
20	144.000	140.000	110.500
21	0.000	140.000	146.500
22	144.000	140.000	146.500
23	36.000	140.000	110.500
24	72.000	140.000	110.500
25	108.000	140.000	110.500
26	36.000	140.000	146.500
27	72.000	140.000	146.500
28	108.000	140.000	146.500
29	0.000	0.000	146.500
30	144.000	0.000	146.500
31	72.000	0.000	146.500
32	48.000	140.000	110.500
33	96.000	140.000	110.500
34	0.000	21.460	0.000
35	0.000	21.460	108.000
36	0.000	127.737	108.000
37	144.000	21.460	108.000
38	144.000	105.255	108.000
39	144.000	127.737	0.000

Beams

Beam	Node A	Node B	Length (in)	Property	β (degrees)
1	1	34	21.000	1	0
2	2	39	125.000	1	0
3	3	35	21.000	1	0
4	4	37	21.000	1	0
5	5	6	144.000	2	0
6	5	9	36.000	2	0
7	6	11	36.000	2	0
8	9	10	36.000	2	0
9	10	7	36.000	2	0
10	11	12	36.000	2	0
11	12	8	36.000	2	0
12	9	13	48.000	2	0
13	13	14	48.000	2	0
14	14	11	48.000	2	0
15	13	17	36.000	2	0
16	7	15	48.000	2	0
17	14	18	36.000	2	0



Software licensed to INEEL

Job No
EDF-5017

Sheet No
121 of 138

Rev

Job Title **V-TANK MOCKUP PLATFORM**

Part

Ref

By **R LIPPERT** Date **12-Mar-04** Chd

Client

File **MockupFrame.std**

Date/Time **30-Jun-2004 16:16**

Beams Cont...

Beam	Node A	Node B	Length (in)	Property	β (degrees)
18	8	16	48.000	2	0
19	17	15	36.000	2	0
20	10	17	48.000	2	0
21	18	16	36.000	2	0
22	12	18	48.000	2	0
23	15	16	48.000	2	0
24	19	23	36.000	3	0
25	21	26	36.000	3	0
26	23	32	12.000	3	0
27	24	33	24.000	3	0
28	25	20	36.000	3	0
29	19	21	36.000	3	0
30	26	27	36.000	3	0
31	23	26	36.000	3	0
32	27	28	36.000	3	0
33	24	27	36.000	3	0
34	28	22	36.000	3	0
35	25	28	36.000	3	0
36	20	22	36.000	3	0
37	29	21	139.000	3	90
38	31	27	139.000	3	90
39	30	22	139.000	3	90
40	7	19	2.500	4	0
41	32	24	24.000	3	0
42	15	32	2.500	4	0
43	33	25	12.000	3	0
44	16	33	2.500	4	0
45	8	20	2.500	4	0
46	34	5	116.000	1	0
47	35	36	104.000	1	0
48	36	7	12.000	1	0
49	37	38	81.999	1	0
50	38	8	34.000	1	0
51	39	6	12.000	1	0
52	34	36	151.522	5	315
53	35	38	166.606	5	315
54	37	39	151.522	5	315



Software licensed to INEEL

Job No
EDF-5017Sheet No
122 of 138

Rev

Part

Job Title **V-TANK MOCKUP PLATFORM**

Ref

By **R LIPPERT** Date **12-Mar-04** Chd

Client

File **MockupFrame.std**Date/Time **30-Jun-2004 16:16**

Section Properties

Prop	Section	Area (in ²)	I _{yy} (in ⁴)	I _{zz} (in ⁴)	J (in ⁴)	Material
1	TUB40403	2.770	6.600	6.600	10.390	STEEL
2	TUB60303	3.140	4.800	14.300	11.619	STEEL
3	TUB40203	2.020	1.300	3.900	3.183	STEEL
4	Prismatic General	100.000	10E 3	10E 3	10E 3	STEEL
5	L40404	1.938	4.853	1.225	0.041	STEEL

Materials

Mat	Name	E (kip/in ²)	v	Density (kip/in ³)	α (1/°K)
1	STEEL	29E 3	0.300	0.000	3.61E -6
2	ALUMINUM	10E 3	0.330	0.000	7.11E -6
3	CONCRETE	3.15E 3	0.170	0.000	3.06E -6

Supports

Node	X (kip/in)	Y (kip/in)	Z (kip/in)	rX (kip ft/deg)	rY (kip ft/deg)	rZ (kip ft/deg)
1	Fixed	Fixed	Fixed			
2	Fixed	Fixed	Fixed			
3	Fixed	Fixed	Fixed			
4	Fixed	Fixed	Fixed	-	-	-
29	Fixed	Fixed	Fixed	-	-	-
30	Fixed	Fixed	Fixed	-	-	-
31	Fixed	Fixed	Fixed	-	-	-

Releases

Beam ends not shown in this table are fixed in all directions.

Beam	Node	x	y	z	rx	ry	rz
23	15	Fixed	Fixed	Fixed	Fixed	Pin	Pin
23	16	Fixed	Fixed	Fixed	Fixed	Pin	Pin
37	21	Fixed	Fixed	Fixed	Fixed	Pin	Pin
38	27	Fixed	Fixed	Fixed	Fixed	Pin	Pin
39	22	Fixed	Fixed	Fixed	Fixed	Pin	Pin
40	19	Fixed	Fixed	Fixed	Fixed	Pin	Pin
42	32	Fixed	Fixed	Fixed	Fixed	Pin	Pin
44	33	Fixed	Fixed	Fixed	Fixed	Pin	Pin
45	20	Fixed	Fixed	Fixed	Fixed	Pin	Pin
52	34	Fixed	Fixed	Fixed	Fixed	Pin	Pin
52	36	Fixed	Fixed	Fixed	Fixed	Pin	Pin
53	35	Fixed	Fixed	Fixed	Fixed	Pin	Pin
53	38	Fixed	Fixed	Fixed	Fixed	Pin	Pin



Software licensed to INEEL

Job No
EDF-5017

Sheet No
123 of 138

Rev

Job Title **V-TANK MOCKUP PLATFORM**

Part

Ref

By **R LIPPERT** Date **12-Mar-04** Chd

Client

File **MockupFrame.std**

Date/Time **30-Jun-2004 16:16**

Releases Cont...

Beam	Node	x	y	z	rx	ry	rz
54	37	Fixed	Fixed	Fixed	Fixed	Pin	Pin
54	39	Fixed	Fixed	Fixed	Fixed	Pin	Pin

Basic Load Cases

Number	Name
1	DEAD LOAD
2	UNIFORM LL
3	CONCEN LL1
4	CONCEN LL2
5	CONCEN LL3
6	CONCEN LL4
7	CONCEN LL5
8	LATLOAD1
9	LATLOAD2
10	LATLOAD3

Combination Load Cases

Comb.	Combination L/C Name	Primary	Primary L/C Name	Factor
11	DL+ULL+LAT1	1	DEAD LOAD	1.00
		2	UNIFORM LL	1.00
		8	LATLOAD1	1.00
12	DL+ULL+LAT2	1	DEAD LOAD	1.00
		2	UNIFORM LL	1.00
		9	LATLOAD2	1.00
13	DL+ULL+LAT3	1	DEAD LOAD	1.00
		2	UNIFORM LL	1.00
		10	LATLOAD3	1.00
14	DL+LL1+LL2	1	DEAD LOAD	1.00
		3	CONCEN LL1	1.00
		4	CONCEN LL2	1.00
15	DL+LL2+LL3	1	DEAD LOAD	1.00
		4	CONCEN LL2	1.00
		5	CONCEN LL3	1.00
16	DL+LL2+LL4	1	DEAD LOAD	1.00
		4	CONCEN LL2	1.00
		6	CONCEN LL4	1.00
17	DL+LL5	1	DEAD LOAD	1.00
		7	CONCEN LL5	1.00



Software licensed to INEEL

Job No EDF-5017	Sheet No 124 of 138	Rev
Part		
Ref		
By R LIPPERT	Date 12-Mar-04	Chd
Client	File MockupFrame.std	Date/Time 30-Jun-2004 16:16

Job Title **V-TANK MOCKUP PLATFORM**

Beam Loads : 1 DEAD LOAD

Beam	Type	Direction	Fa	Da (in)	Fb	Db	Ecc. (in)
5	UNI lbf/ft	GY	-11.000	-	-	-	-
12	UNI lbf/ft	GY	-22.000	-	-	-	-
13	UNI lbf/ft	GY	-22.000	-	-	-	-
14	UNI lbf/ft	GY	-22.000	-	-	-	-
16	UNI lbf/ft	GY	-22.000	-	-	-	-
18	UNI lbf/ft	GY	-22.000	-	-	-	-
20	UNI lbf/ft	GY	-22.000	-	-	-	-
22	UNI lbf/ft	GY	-22.000	-	-	-	-
23	UNI lbf/ft	GY	-22.000	-	-	-	-
25	UNI lbf/ft	GY	-11.000	-	-	-	-
30	UNI lbf/ft	GY	-11.000	-	-	-	-
32	UNI lbf/ft	GY	-11.000	-	-	-	-
34	UNI lbf/ft	GY	-11.000	-	-	-	-

Selfweight : 1 DEAD LOAD

Direction	Factor
Y	-1.000

Beam Loads : 2 UNIFORM LL

Beam	Type	Direction	Fa	Da (in)	Fb	Db	Ecc. (in)
5	UNI lbf/ft	GY	-60.000	-	-	-	-
12	UNI lbf/ft	GY	-120.000	-	-	-	-
13	UNI lbf/ft	GY	-120.000	-	-	-	-
14	UNI lbf/ft	GY	-120.000	-	-	-	-
16	UNI lbf/ft	GY	-120.000	-	-	-	-
18	UNI lbf/ft	GY	-120.000	-	-	-	-
20	UNI lbf/ft	GY	-120.000	-	-	-	-
22	UNI lbf/ft	GY	-120.000	-	-	-	-
23	UNI lbf/ft	GY	-120.000	-	-	-	-
25	UNI lbf/ft	GY	-60.000	-	-	-	-
30	UNI lbf/ft	GY	-60.000	-	-	-	-
32	UNI lbf/ft	GY	-60.000	-	-	-	-
34	UNI lbf/ft	GY	-60.000	-	-	-	-

Beam Loads : 3 CONCEN LL1

Beam	Type	Direction	Fa	Da (in)	Fb	Db	Ecc. (in)
13	CON lb	GY	-300.000	-	-	-	-



Software licensed to INEEL

Job No EDF-5017	Sheet No 125 of 138	Rev
---------------------------	-------------------------------	-----

Part

Job Title V-TANK MOCKUP PLATFORM	Ref
---	-----

By R LIPPERT	Date 12-Mar-04	Chd
---------------------	-----------------------	-----

Client	File MockupFrame.std	Date/Time 30-Jun-2004 16:16
--------	-----------------------------	------------------------------------

Beam	Type	Direction	Fa	Da (in)	Fb	Db	Ecc. (in)
22	CON lb	GY	-300.000				

Beam	Type	Direction	Fa	Da (in)	Fb	Db	Ecc. (in)
20	CON lb	GY	-300.000				

Beam	Type	Direction	Fa	Da (in)	Fb	Db	Ecc. (in)
23	CON lb	GY	-300.000				

Beam	Type	Direction	Fa	Da (in)	Fb	Db	Ecc. (in)
33	CON lb	GY	-300.000				

Node Loads : 8 LATLOAD1

Node	FX (lb)	FY (lb)	FZ (lb)	MX (kip'in)	MY (kip'in)	MZ (kip'in)
27	-250.000	-	-	-	-	-

Node Loads : 9 LATLOAD2

Node	FX (lb)	FY (lb)	FZ (lb)	MX (kip'in)	MY (kip'in)	MZ (kip'in)
14	-250.000					

Node Loads : 10 LATLOAD3

Node	FX (lb)	FY (lb)	FZ (lb)	MX (kip'in)	MY (kip'in)	MZ (kip'in)
10			-250.000			



Software licensed to INEEL

Job No EDF-5017	Sheet No 126 of 138	Rev
Part		
Ref		
By R LIPPERT	Date 12-Mar-04	Chd
Client	File MockupFrame.std	Date/Time 30-Jun-2004 16:16

Job Title **V-TANK MOCKUP PLATFORM**

Node Displacement Summary

	Node	L/C	X (in)	Y (in)	Z (in)	Resultant (in)	rX (rad)	rY (rad)	rZ (rad)
Max X	37	16:DL+LL2+LL	0.000	-0.000	0.010	0.010	0.000	-0.000	0.000
Min X	21	11:DL+ULL+LA	-0.234	0.000	-0.047	0.238	-0.000	-0.001	-0.001
Max Y	19	13:DL+ULL+LA	-0.139	0.001	-0.069	0.155	-0.000	-0.001	-0.003
Min Y	14	11:DL+ULL+LA	-0.145	-0.208	0.021	0.254	-0.000	-0.001	0.002
Max Z	38	11:DL+ULL+LA	-0.090	-0.002	0.080	0.120	-0.000	-0.001	0.002
Min Z	10	13:DL+ULL+LA	-0.107	-0.053	-0.069	0.138	-0.001	-0.001	-0.003
Max rX	5	13:DL+ULL+LA	-0.053	-0.003	-0.069	0.087	0.002	-0.001	-0.002
Min rX	27	11:DL+ULL+LA	-0.233	-0.003	0.007	0.233	-0.005	-0.001	-0.000
Max rY	16	12:DL+ULL+LA	-0.192	-0.163	0.015	0.253	-0.001	0.000	0.003
Min rY	15	13:DL+ULL+LA	-0.137	-0.146	-0.029	0.203	-0.001	-0.001	-0.003
Max rZ	3	11:DL+ULL+LA	0.000	0.000	0.000	0.000	0.000	-0.001	0.004
Min rZ	9	11:DL+ULL+LA	-0.145	-0.054	-0.047	0.162	0.001	-0.001	-0.004
Max Rst	24	11:DL+ULL+LA	-0.199	-0.191	0.007	0.276	-0.005	-0.001	-0.000

Beam Force Detail Summary

Sign convention as diagrams: - positive above line, negative below line except Fx where positive is compression. Distance d is given from beam end A.

	Beam	L/C	d (in)	Axial			Shear			Torsion	Bending	
				Fx (lb)	Fy (lb)	Fz (lb)	Mx (kip'in)	My (kip'in)	Mz (kip'in)			
Max Fx	41	11:DL+ULL+LA	0.000	3.01E 3	-41.287	33.054	2.433	-0.234	-13.028			
Min Fx	23	11:DL+ULL+LA	0.000	-3.11E 3	305.327	-0.000	-0.190	0.000	0.000			
Max Fy	12	11:DL+ULL+LA	0.000	84.559	1.09E 3	-39.637	2.729	0.830	8.283			
Min Fy	14	11:DL+ULL+LA	48.000	34.863	-1.08E 3	50.648	-2.457	1.412	7.087			
Max Fz	44	12:DL+ULL+LA	0.000	30.145	-342.673	2.17E 3	14.117	-5.414	-0.945			
Min Fz	42	11:DL+ULL+LA	0.000	-1.352	-234.147	-2.49E 3	-11.787	6.232	-0.674			
Max Mx	44	11:DL+ULL+LA	0.000	-16.070	-349.860	2.09E 3	14.138	-5.234	-0.963			
Min Mx	42	12:DL+ULL+LA	0.000	-46.638	-232.549	-2.4E 3	-11.840	6.009	-0.670			
Max My	46	12:DL+ULL+LA	116.000	1.45E 3	-86.245	78.929	-0.007	8.035	11.809			
Min My	50	12:DL+ULL+LA	34.000	1.85E 3	-94.110	-64.490	-0.002	-6.561	-5.276			
Max Mz	48	13:DL+ULL+LA	12.000	1.93E 3	-141.154	266.063	0.005	-1.908	17.106			
Min Mz	13	11:DL+ULL+LA	24.000	103.702	18.296	26.720	-0.189	-0.121	-35.963			



Software licensed to INEEL

Job No
EDF-5017Sheet No
127 of 138

Rev

Part

Job Title **V-TANK MOCKUP PLATFORM**

Ref

By **R LIPPERT**Date **12-Mar-04**

Chd

Client

File **MockupFrame.std**Date/Time **30-Jun-2004 16:16**

Reactions

Node	L/C	Horizontal	Vertical	Horizontal	Moment		
		FX (lb)	FY (lb)	FZ (lb)	MX (kip'in)	MY (kip'in)	MZ (kip'in)
1	1:DEAD LOAD	19.352	537.093	15.103	0.000	0.000	0.000
	11:DL+ULL+LA	77.773	1.69E 3	131.136	0.000	0.000	0.000
	12:DL+ULL+LA	86.245	1.47E 3	-50.512	0.000	0.000	0.000
	13:DL+ULL+LA	64.896	1.88E 3	298.496	0.000	0.000	0.000
	14:DL+LL1+LL	24.842	656.840	19.564	0.000	0.000	0.000
	15:DL+LL2+LL	22.149	638.748	21.589	0.000	0.000	0.000
	16:DL+LL2+LL	24.525	565.971	19.985	0.000	0.000	0.000
	17:DL+LL5	21.532	541.274	17.221	0.000	0.000	0.000
2	1:DEAD LOAD	-10.043	501.425	10.874	0.000	0.000	0.000
	11:DL+ULL+LA	-34.711	1.35E 3	41.676	0.000	0.000	0.000
	12:DL+ULL+LA	-26.120	1.56E 3	38.416	0.000	0.000	0.000
	13:DL+ULL+LA	-45.885	1.48E 3	40.691	0.000	0.000	0.000
	14:DL+LL1+LL	-14.499	681.678	19.233	0.000	0.000	0.000
	15:DL+LL2+LL	-11.962	599.770	16.137	0.000	0.000	0.000
	16:DL+LL2+LL	-9.426	572.547	15.410	0.000	0.000	0.000
	17:DL+LL5	-9.137	493.772	10.966	0.000	0.000	0.000
3	1:DEAD LOAD	7.875	827.203	-8.122	0.000	0.000	0.000
	11:DL+ULL+LA	287.282	2.2E 3	-31.999	0.000	0.000	0.000
	12:DL+ULL+LA	268.410	2.41E 3	-29.394	0.000	0.000	0.000
	13:DL+ULL+LA	36.935	1.77E 3	-34.237	0.000	0.000	0.000
	14:DL+LL1+LL	12.632	907.214	-11.807	0.000	0.000	0.000
	15:DL+LL2+LL	11.678	1.03E 3	-13.949	0.000	0.000	0.000
	16:DL+LL2+LL	11.325	998.038	-8.660	0.000	0.000	0.000
	17:DL+LL5	8.458	897.976	-7.925	0.000	0.000	0.000
4	1:DEAD LOAD	-17.184	863.306	-17.855	0.000	0.000	0.000
	11:DL+ULL+LA	-80.344	2.05E 3	-140.813	0.000	0.000	0.000
	12:DL+ULL+LA	-78.536	1.84E 3	41.490	0.000	0.000	0.000
	13:DL+ULL+LA	-55.946	2.16E 3	-54.949	0.000	0.000	0.000
	14:DL+LL1+LL	-22.975	1.08E 3	-26.990	0.000	0.000	0.000
	15:DL+LL2+LL	-21.864	1.07E 3	-23.777	0.000	0.000	0.000
	16:DL+LL2+LL	-26.425	1.19E 3	-26.735	0.000	0.000	0.000
	17:DL+LL5	-20.853	946.006	-20.262	0.000	0.000	0.000
29	1:DEAD LOAD	0.000	53.160	0.000	0.000	0.000	0.000
	11:DL+ULL+LA	0.000	-9.269	0.000	0.000	0.000	0.000
	12:DL+ULL+LA	0.000	-3.462	0.000	0.000	0.000	0.000
	13:DL+ULL+LA	0.000	16.957	0.000	0.000	0.000	0.000
	14:DL+LL1+LL	0.000	30.421	0.000	0.000	0.000	0.000
	15:DL+LL2+LL	0.000	31.349	0.000	0.000	0.000	0.000
	16:DL+LL2+LL	0.000	10.234	0.000	0.000	0.000	0.000
	17:DL+LL5	0.000	33.523	0.000	0.000	0.000	0.000
30	1:DEAD LOAD	0.000	52.725	-0.000	0.000	0.000	0.000
	11:DL+ULL+LA	0.000	-6.006	0.000	0.000	0.000	0.000
	12:DL+ULL+LA	0.000	-7.610	0.000	0.000	0.000	0.000
	13:DL+ULL+LA	0.000	16.985	0.000	0.000	0.000	0.000
	14:DL+LL1+LL	0.000	29.502	-0.000	0.000	0.000	0.000



Software licensed to INEEL

Job No EDF-5017	Sheet No 128 of 138	Rev
Part		
Ref		
By R LIPPERT	Date 12-Mar-04	Chd
Client	File MockupFrame.std	Date/Time 30-Jun-2004 16:16

Job Title **V-TANK MOCKUP PLATFORM**

Reactions Cont...

Node	L/C	Horizontal	Vertical	Horizontal	Moment		
		FX (lb)	FY (lb)	FZ (lb)	MX (kip'in)	MY (kip'in)	MZ (kip'in)
	15:DL+LL2+LL	0.000	30.815	-0.000	0.000	0.000	0.000
	16:DL+LL2+LL	0.000	9.227	-0.000	0.000	0.000	0.000
	17:DL+LL5	0.000	32.994	-0.000	0.000	0.000	0.000
31	1:DEAD LOAD	0.000	398.266	-0.000	0.000	0.000	0.000
	11:DL+ULL+LA	0.000	1.24E 3	-0.000	0.000	0.000	0.000
	12:DL+ULL+LA	0.000	1.24E 3	-0.000	0.000	0.000	0.000
	13:DL+ULL+LA	0.000	1.19E 3	0.000	0.000	0.000	0.000
	14:DL+LL1+LL	0.000	444.227	-0.000	0.000	0.000	0.000
	15:DL+LL2+LL	0.000	441.987	-0.000	0.000	0.000	0.000
	16:DL+LL2+LL	0.000	484.689	-0.000	0.000	0.000	0.000
	17:DL+LL5	0.000	587.634	-0.000	0.000	0.000	0.000

Failure Ratio

Beam	Analysis Property	New Property	Ratio	Ay (in ²)	Az (in ²)	Ax (in ²)	Dw (in)	Bf (in)	Iz (in ⁴)	Iy (in ⁴)	Ix (in ⁴)
1	TUB40403	TUB40403	0.101	1.500	1.500	2.770	4.000	4.000	6.600	6.600	10.600
2	TUB40403	TUB40403	0.136	1.500	1.500	2.770	4.000	4.000	6.600	6.600	10.600
3	TUB40403	TUB40403	0.096	1.500	1.500	2.770	4.000	4.000	6.600	6.600	10.600
4	TUB40403	TUB40403	0.074	1.500	1.500	2.770	4.000	4.000	6.600	6.600	10.600
5	TUB60303	TUB60303	0.127	2.250	1.125	3.140	6.000	3.000	14.300	4.800	11.900
6	TUB60303	TUB60303	0.185	2.250	1.125	3.140	6.000	3.000	14.300	4.800	11.900
7	TUB60303	TUB60303	0.186	2.250	1.125	3.140	6.000	3.000	14.300	4.800	11.900
8	TUB60303	TUB60303	0.174	2.250	1.125	3.140	6.000	3.000	14.300	4.800	11.900
9	TUB60303	TUB60303	0.121	2.250	1.125	3.140	6.000	3.000	14.300	4.800	11.900
10	TUB60303	TUB60303	0.173	2.250	1.125	3.140	6.000	3.000	14.300	4.800	11.900
11	TUB60303	TUB60303	0.109	2.250	1.125	3.140	6.000	3.000	14.300	4.800	11.900
12	TUB60303	TUB60303	0.216	2.250	1.125	3.140	6.000	3.000	14.300	4.800	11.900
13	TUB60303	TUB60303	0.280	2.250	1.125	3.140	6.000	3.000	14.300	4.800	11.900
14	TUB60303	TUB60303	0.218	2.250	1.125	3.140	6.000	3.000	14.300	4.800	11.900
15	TUB60303	TUB60303	0.066	2.250	1.125	3.140	6.000	3.000	14.300	4.800	11.900
16	TUB60303	TUB60303	0.127	2.250	1.125	3.140	6.000	3.000	14.300	4.800	11.900
17	TUB60303	TUB60303	0.067	2.250	1.125	3.140	6.000	3.000	14.300	4.800	11.900
18	TUB60303	TUB60303	0.146	2.250	1.125	3.140	6.000	3.000	14.300	4.800	11.900
19	TUB60303	TUB60303	0.065	2.250	1.125	3.140	6.000	3.000	14.300	4.800	11.900
20	TUB60303	TUB60303	0.049	2.250	1.125	3.140	6.000	3.000	14.300	4.800	11.900
21	TUB60303	TUB60303	0.059	2.250	1.125	3.140	6.000	3.000	14.300	4.800	11.900
22	TUB60303	TUB60303	0.047	2.250	1.125	3.140	6.000	3.000	14.300	4.800	11.900
23	TUB60303	TUB60303	0.061	2.250	1.125	3.140	6.000	3.000	14.300	4.800	11.900
24	TUB40203	TUB40203	0.120	1.500	0.750	2.020	4.000	2.000	3.900	1.300	3.800
25	TUB40203	TUB40203	0.063	1.500	0.750	2.020	4.000	2.000	3.900	1.300	3.800
26	TUB40203	TUB40203	0.079	1.500	0.750	2.020	4.000	2.000	3.900	1.300	3.800
27	TUB40203	TUB40203	0.368	1.500	0.750	2.020	4.000	2.000	3.900	1.300	3.800
28	TUB40203	TUB40203	0.113	1.500	0.750	2.020	4.000	2.000	3.900	1.300	3.800



Software licensed to INEEL

Job No
EDF-5017

Sheet No
129 of 138

Rev

Part

Job Title **V-TANK MOCKUP PLATFORM**

Ref

By **R LIPPERT** Date **2-Mar-04** Chd

Client

File **MockupFrame.std**

Date/Time **30-Jun-2004 16:16**

Failure Ratio Cont...

Beam	Analysis Property	New Property	Ratio	Ay (in ²)	Az (in ²)	Ax (in ²)	Dw (in)	Bf (in)	Iz (in ⁴)	Iy (in ⁴)	Ix (in ⁴)
29	TUB40203	TUB40203	0.079	1.500	0.750	2.020	4.000	2.000	3.900	1.300	3.800
30	TUB40203	TUB40203	0.143	1.500	0.750	2.020	4.000	2.000	3.900	1.300	3.800
31	TUB40203	TUB40203	0.044	1.500	0.750	2.020	4.000	2.000	3.900	1.300	3.800
32	TUB40203	TUB40203	0.135	1.500	0.750	2.020	4.000	2.000	3.900	1.300	3.800
33	TUB40203	TUB40203	0.118	1.500	0.750	2.020	4.000	2.000	3.900	1.300	3.800
34	TUB40203	TUB40203	0.067	1.500	0.750	2.020	4.000	2.000	3.900	1.300	3.800
35	TUB40203	TUB40203	0.042	1.500	0.750	2.020	4.000	2.000	3.900	1.300	3.800
36	TUB40203	TUB40203	0.075	1.500	0.750	2.020	4.000	2.000	3.900	1.300	3.800
37	TUB40203	TUB40203	0.005	1.500	0.750	2.020	4.000	2.000	3.900	1.300	3.800
38	TUB40203	TUB40203	0.123	1.500	0.750	2.020	4.000	2.000	3.900	1.300	3.800
39	TUB40203	TUB40203	0.005	1.500	0.750	2.020	4.000	2.000	3.900	1.300	3.800
40	Prismatic Gene	1X 1	0.000	100.000	100.000	100.000	1.000	1.000	10E 3	10E 3	10E 3
41	TUB40203	TUB40203	0.308	1.500	0.750	2.020	4.000	2.000	3.900	1.300	3.800
42	Prismatic Gene	1X 1	0.000	100.000	100.000	100.000	1.000	1.000	10E 3	10E 3	10E 3
43	TUB40203	TUB40203	0.095	1.500	0.750	2.020	4.000	2.000	3.900	1.300	3.800
44	Prismatic Gene	1X 1	0.000	100.000	100.000	100.000	1.000	1.000	10E 3	10E 3	10E 3
45	Prismatic Gene	1X 1	0.000	100.000	100.000	100.000	1.000	1.000	10E 3	10E 3	10E 3
46	TUB40403	TUB40403	0.226	1.500	1.500	2.770	4.000	4.000	6.600	6.600	10.600
47	TUB40403	TUB40403	0.232	1.500	1.500	2.770	4.000	4.000	6.600	6.600	10.600
48	TUB40403	TUB40403	0.247	1.500	1.500	2.770	4.000	4.000	6.600	6.600	10.600
49	TUB40403	TUB40403	0.160	1.500	1.500	2.770	4.000	4.000	6.600	6.600	10.600
50	TUB40403	TUB40403	0.197	1.500	1.500	2.770	4.000	4.000	6.600	6.600	10.600
51	TUB40403	TUB40403	0.135	1.500	1.500	2.770	4.000	4.000	6.600	6.600	10.600
52	L40404	L40404	0.129	0.667	0.667	1.938	4.000	4.000	1.225	4.854	0.040
53	L40404	L40404	1.048	0.667	0.667	1.938	4.000	4.000	1.225	4.854	0.040
54	L40404	L40404	0.097	0.667	0.667	1.938	4.000	4.000	1.225	4.854	0.040



Software licensed to INEEL

Job No
EDF-5017

Sheet No
130 of 138

Rev

Job Title **V-TANK MOCKUP PLATFORM**

Part

Ref

By **R LIPPERT**

Date **12-Mar-04**

Chd

Client

File **MockupFrame.std**

Date/Time **30-Jun-2004 16:16**

Steel Design (Track 2) Beam 53 Check 1

MEMBER 53		AISC SECTIONS	PROPERTIES		
DESIGN CODE		ST L40404	IN INCH UNIT		
AISC-1989			AX =	1.94	
<---LENGTH (FT) = 13.88 --->			AY =	0.67	
			AZ =	0.67	
			SY =	1.72	
			SZ =	0.79	
			RY =	1.58	
			RZ =	0.80	
PARAMETER		STRESSES			
IN KIP	INCH	IN KIP	INCH		
KL/R-Y=	105.28	FA =	0.00		
KL/R-Z=	209.57	fa =	0.00		
UNL =	166.61	FCZ =	0.00		
CB =	1.00	FTZ =	0.00		
CMY =	0.85	FCY =	0.00		
CMZ =	0.85	FTY =	0.00		
FYLD =	36.00	fbz =	0.00		
NSF =	1.00	fby =	0.00		
DFP =	0.00	Fey =	0.00		
dfp =	0.00	Fez =	0.00		
		FV =	0.00		
		fv =	0.00		
ABSOLUTE MZ ENVELOPE (WITH LOAD NO.)					
MAX FORCE/ MOMENT SUMMARY (KIP-FEET)					
VALUE	AXIAL	SHEAR-Y	SHEAR-Z	MOMENT-Y	MOMENT-Z
13.9	-0.1	0.0	0.0	0.1	0.1
LOADING	13.9	13.9	13.9	6.9	6.9
	1	1	1	1	1
DESIGN SUMMARY (KIP-FEET)					
RESULT/FX	CRITICAL COND/ MY	RATIO/ MZ	LOADING/ LOCATION		
FAIL	L/R-EXCEEDS	1.048E+00	11		
0.25 C	0.10	-0.10	6.94		

Attachment 7
Design Drawings

EDF-5017 139/38

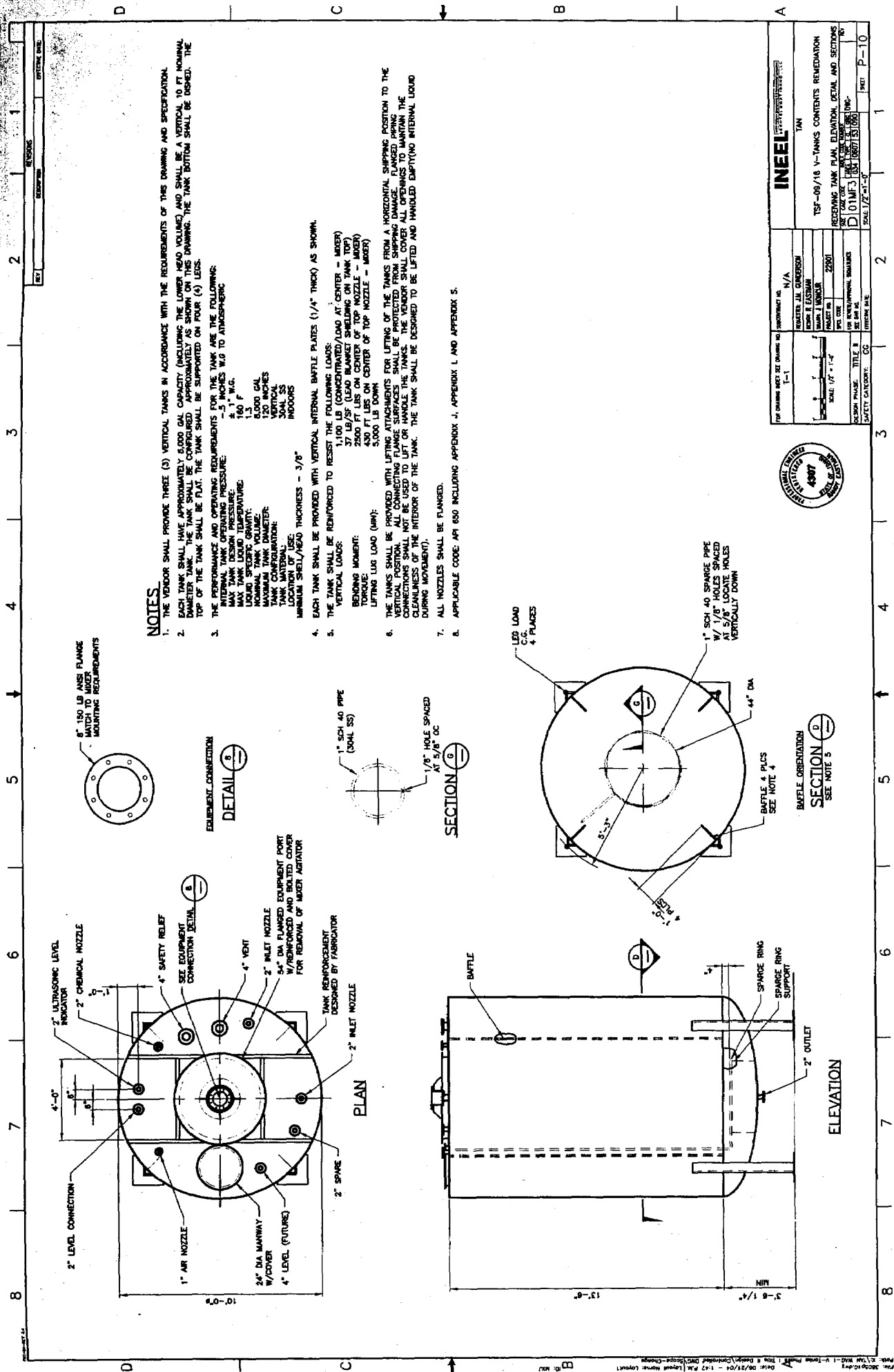

NOTES

1. THE VENDOR SHALL PROVIDE THREE (3) VERTICAL TANKS IN ACCORDANCE WITH THE REQUIREMENTS OF THIS DRAWING AND SPECIFICATION. EACH TANK SHALL HAVE APPROXIMATELY 6,000 GAL CAPACITY (INCLUDING THE LOWER HEAD VOLUME) AND SHALL BE A VERTICAL 10 FT NOMINAL DIAMETER TANK. THE TANK SHALL BE CONFIGURED APPROXIMATELY AS SHOWN ON THIS DRAWING. THE TANK BOTTOM SHALL BE DISKED. THE TOP OF THE TANK SHALL BE FLAT. THE TANK SHALL BE SUPPORTED ON FOUR (4) LEGS.
2. THE PERFORMANCE AND OPERATING REQUIREMENTS FOR THE TANK ARE THE FOLLOWING:
 MAX TANK DESIGN PRESSURE: 4.1" W.G.
 MAX TANK DESIGN TEMPERATURE: 180 F
 LIQUID SPECIFIC GRAVITY: 1.3
 LIQUID VISCOSITY: 1000 CEN
 MAXIMUM TANK DIAMETER: 120 INCHES
 TANK CONFIGURATION: VERTICAL
 TANK MATERIALS: 304L SS
 MINIMUM SHELL/HEAD THICKNESS: 3/8"
3. EACH TANK SHALL BE PROVIDED WITH VERTICAL INTERNAL BAFFLE PLATES (1/4" THICK) AS SHOWN.
4. THE TANK SHALL BE REINFORCED TO RESIST THE FOLLOWING LOADS:
 VERTICAL LOADS:
 1,100 LB (CONCENTRATED/LOAD AT CENTER - MIXER)
 37 LB/SP (LEAD BLANKET SHELLING ON TANK WALL)
 430 FT LBS (ON CENTER OF TOP NOZZLE - MIXER)
 BENDING MOMENT:
 5,000 LB DOWN
 LIFTING LIFT LOAD (MIN):
 3,000 LB DOWN
5. THE TANKS SHALL BE PROVIDED WITH LIFTING ATTACHMENTS FOR LIFTING OF THE TANKS FROM A HORIZONTAL SHIPPING POSITION TO THE VERTICAL POSITION. ALL CONNECTING FLANGE SURFACES SHALL BE PROTECTED FROM SHIPPING DAMAGE. FLANGED JIPING CONNECTIONS SHALL NOT BE USED TO LIFT OR HANDLE THE TANKS. THE VENDOR SHALL COVER ALL OPENINGS TO MAINTAIN THE CLEANLINESS OF THE INTERIOR OF THE TANK. THE TANK SHALL BE DESIGNED TO BE LIFTED AND HANDLED EMPTY (NO INTERNAL LIQUID DURING MOVEMENT).
6. ALL NOZZLES SHALL BE FLANGED.
7. APPLICABLE CODE: API 650 INCLUDING APPENDIX J, APPENDIX L AND APPENDIX 5.

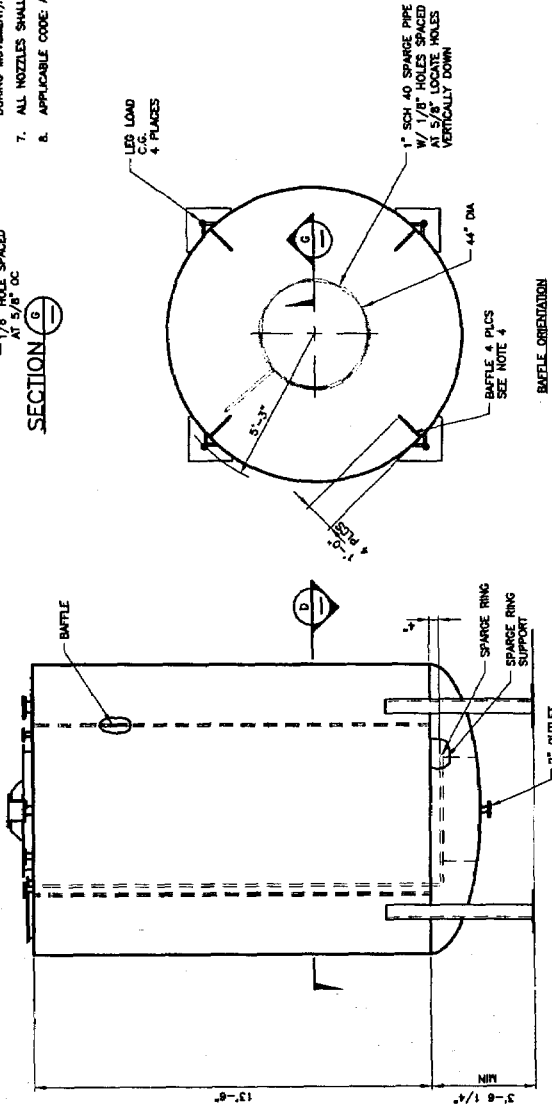
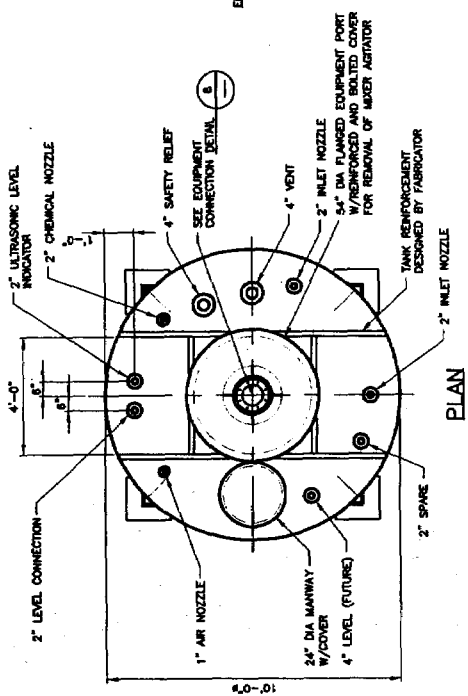
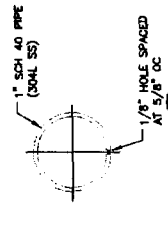
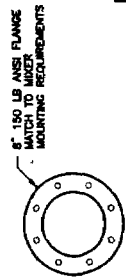

FOR CHANGES REFER TO DRAWING NO. 1-1		APPROVED BY: N/A	DATE: 08/25/04
DRAWN BY: J. EASTMAN		DESIGNED BY: J. EASTMAN	CHECKED BY: J. EASTMAN
PROJECT NO: 22001		SCALE: 1/2" = 1'-0"	DATE: 08/25/04
SHEET NO: 1		TOTAL SHEETS: 1	PROJECT: EDF-5017
TITLE: V-TANKS CONTENTS RENOVATION		SCALE: 1/2" = 1'-0"	SHEET: P-10



BAFFLE ORIENTATION
SECTION 5
SEE NOTE 5

ELEVATION

8 7 6 5 4 3 2 1

EDF-5017 133/138

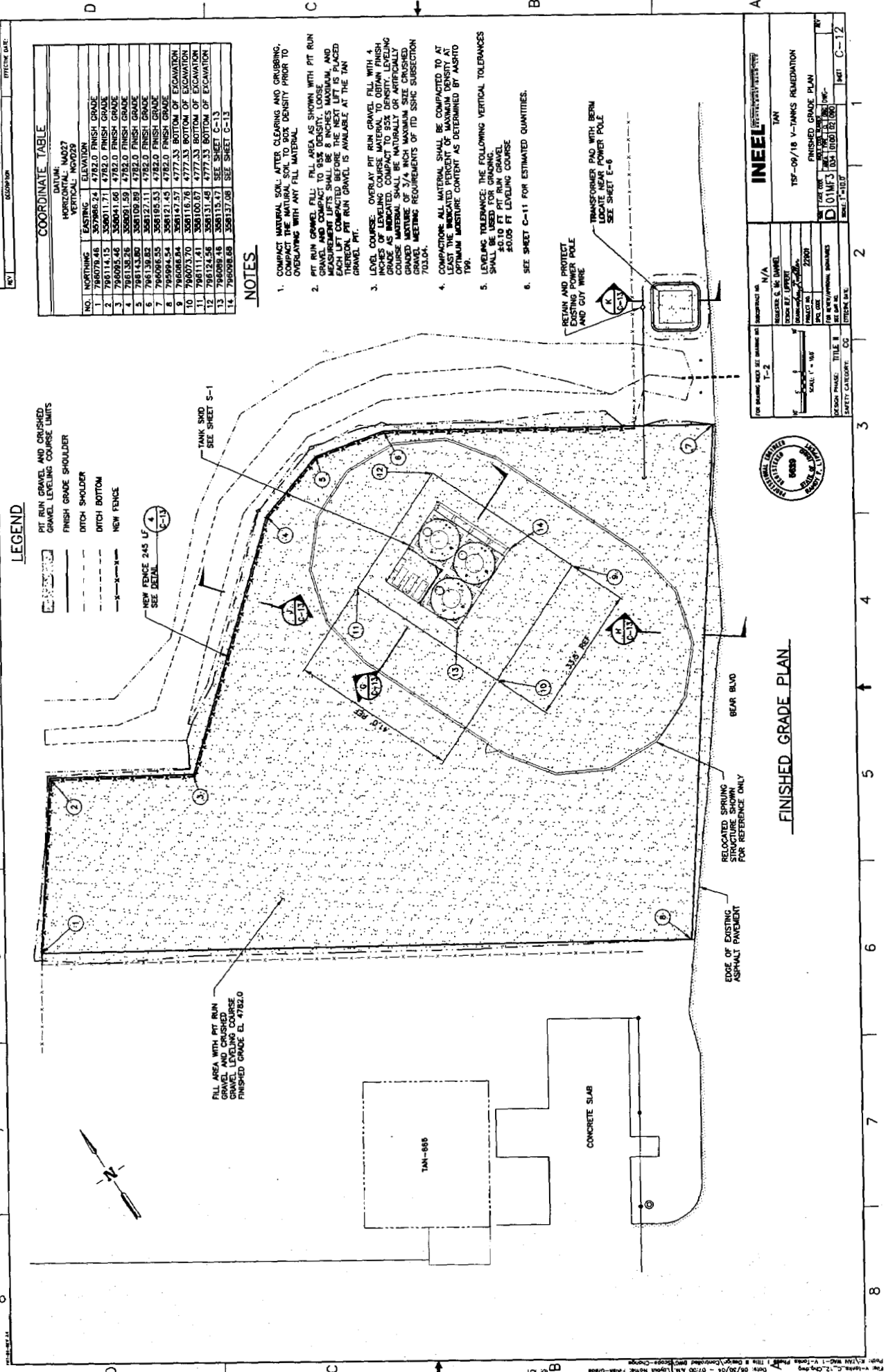

COORDINATE TABLE

NO.	NORTHING	EASTING	ELEVATION
1	796070.48	357886.24	4782.0 FINISH GRADE
2	796114.15	356011.71	4782.0 FINISH GRADE
3	796095.48	356041.66	4782.0 FINISH GRADE
4	796138.28	356091.59	4782.0 FINISH GRADE
5	796143.80	356109.89	4782.0 FINISH GRADE
6	796138.82	356127.11	4782.0 FINISH GRADE
7	796096.55	356185.33	4782.0 FINISH GRADE
8	795994.54	356121.45	4782.0 FINISH GRADE
9	796096.84	356147.57	4782.0 FINISH GRADE
10	796075.70	356100.69	4777.33 BOTTOM OF EXCAVATION
11	796111.41	356100.69	4777.33 BOTTOM OF EXCAVATION
12	796098.48	356131.48	4777.33 BOTTOM OF EXCAVATION
13	796098.48	356115.92	SEE SHEET C-13
14	796098.68	356137.08	SEE SHEET C-13

NOTES

1. COMPACT MATERIAL SOIL AFTER CLEARING AND GRUBBING, AND AFTER GRADING TO DESIRED DENSITY PRIOR TO OVERLAYING WITH ANY FILL MATERIAL.
2. PIT RUN GRAVEL FILL AREA AS SHOWN WITH PIT RUN GRAVEL FILL COURSE SHALL BE 8 INCHES MAXIMUM, AND GRAVEL FILL COURSE SHALL BE 8 INCHES MAXIMUM, AND EACH LIFT COMPACTED BEFORE THE NEXT LIFT IS PLACED THEREON. PIT RUN GRAVEL IS AVAILABLE AT THE TAN GRAVEL PIT.
3. LEVEL COURSE: OVERLAY PIT RUN GRAVEL FILL WITH 4 INCHES OF LEVELING COURSE MATERIAL TO OBTAIN FINISH GRADE AS INDICATED. FINISH GRADE SHALL BE NATURALLY OR ARTIFICIALLY GRADED MATERIAL OF 3/4 INCH MAXIMUM SIZE CRUSHED GRAVEL MEETING REQUIREMENTS OF ITS SSKC SUBSECTION 703.04.
4. COMPACTORS: ALL MATERIAL SHALL BE COMPACTED TO AT LEAST THE INDICATED PERCENT OF MAXIMUM DENSITY AT OPTIMUM MOISTURE CONTENT AS DETERMINED BY ASTM D 1557.
5. LEVELING TOLERANCE: THE FOLLOWING VERTICAL TOLERANCES SHALL BE USED FOR GRADING:
 20.10 FT LEVING COURSE
 20.00 FT LEVING COURSE
6. SEE SHEET C-11 FOR ESTIMATED QUANTITIES.

- LEGEND**
- PIT RUN GRAVEL AND CRUSHED GRAVEL LEVELING COURSE LIMITS
 - FINISH GRADE SHOULDER
 - DITCH SHOULDER
 - DITCH BOTTOM
 - NEW FENCE
 - NEW FENCE 24S LF SEE DETAIL C-13
 - TANK SHED S-1 SEE SHEET S-1
 - RELOCATED SPRING FOR REFERENCE ONLY
 - EDGE OF EXISTING ASPHALT PAVEMENT
 - BEAR BLVD
 - CONCRETE SLAB
 - TAN-885
 - TRANSFORMER PAD WITH BERM LOCATE NEAR POWER POLE SEE SHEET E-6
 - RETAIN AND PROTECT EXISTING POWER POLE AND GUY WIRE

INTEL

TSF-09/18 V-TANKS REMEDIATION

FINISHED GRADE PLAN

DATE: 01/15/18

SCALE: 1" = 40'

PROJECT NO: EDF-5017

SHEET NO: 133 OF 138

DATE: 01/15/18

BY: [Signature]

FOR: [Signature]

DESIGN PHASE: TITLE II

SAFETY CATEGORY: CO

OTHER USE:



FINISHED GRADE PLAN

EDF-5017 124/130

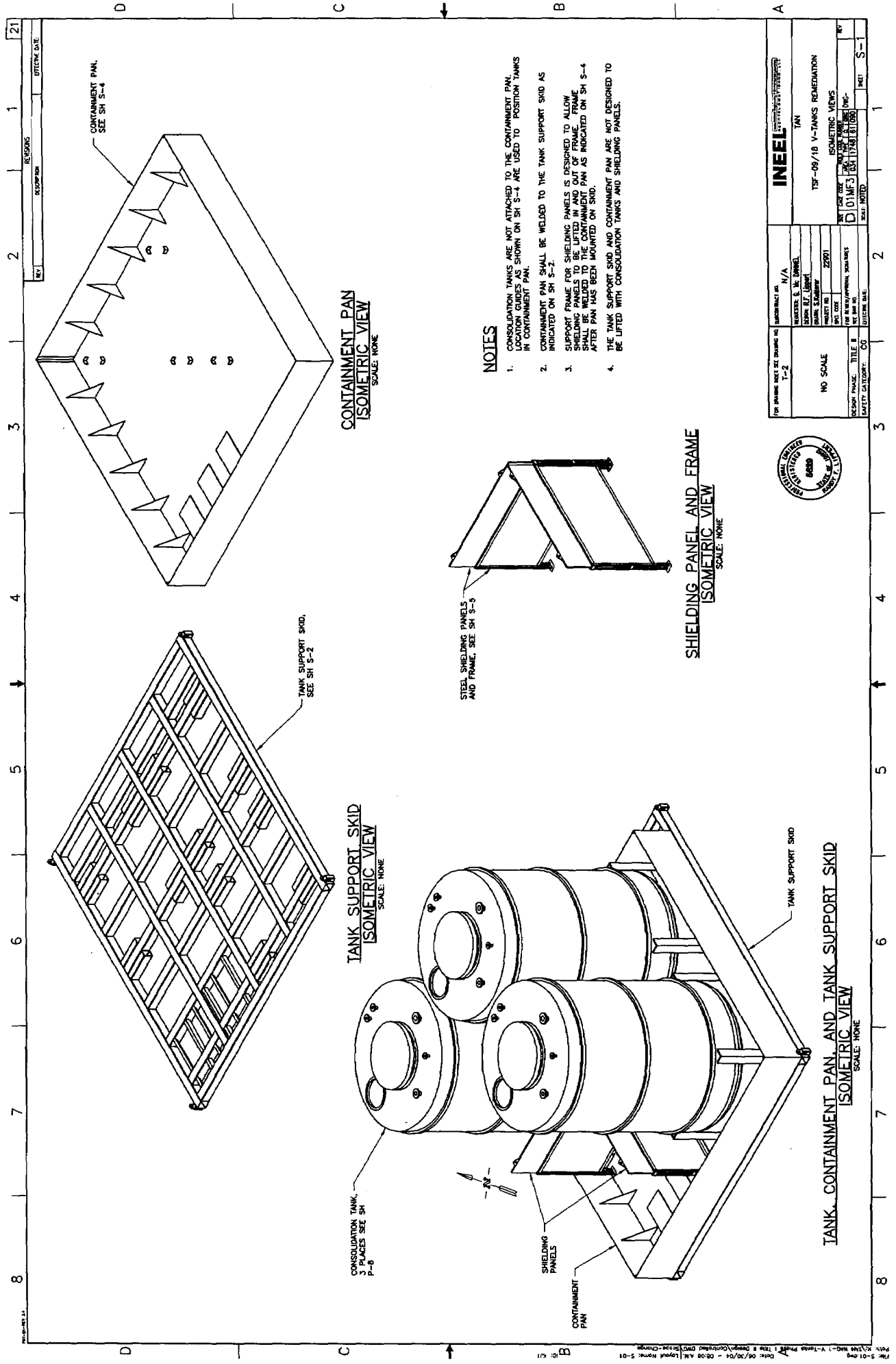

FOR DRAWING SHEET SEE DRAWING NO. T-2	PROJECT NO. N/A	CONTRACT NO. 175F-09/18 V-TANKS REMEDIATION
NO SCALE	DESIGNED BY: J. M. DANIEL	DRAWN BY: J. M. DANIEL
	CHECKED BY: J. M. DANIEL	DATE: 08/20/04
	PROJECT NO. 22001	DATE: 08/20/04
	PROJECT NAME: V-TANKS REMEDIATION	DATE: 08/20/04
	PROJECT LOCATION: 175F-09/18 V-TANKS REMEDIATION	DATE: 08/20/04
	PROJECT NUMBER: 175F-09/18 V-TANKS REMEDIATION	DATE: 08/20/04
	PROJECT SHEET NO. 175F-09/18 V-TANKS REMEDIATION	DATE: 08/20/04
	PROJECT SHEET TOTAL: 175F-09/18 V-TANKS REMEDIATION	DATE: 08/20/04
	PROJECT SHEET NO. 175F-09/18 V-TANKS REMEDIATION	DATE: 08/20/04
	PROJECT SHEET TOTAL: 175F-09/18 V-TANKS REMEDIATION	DATE: 08/20/04



EDF-5017 125/130

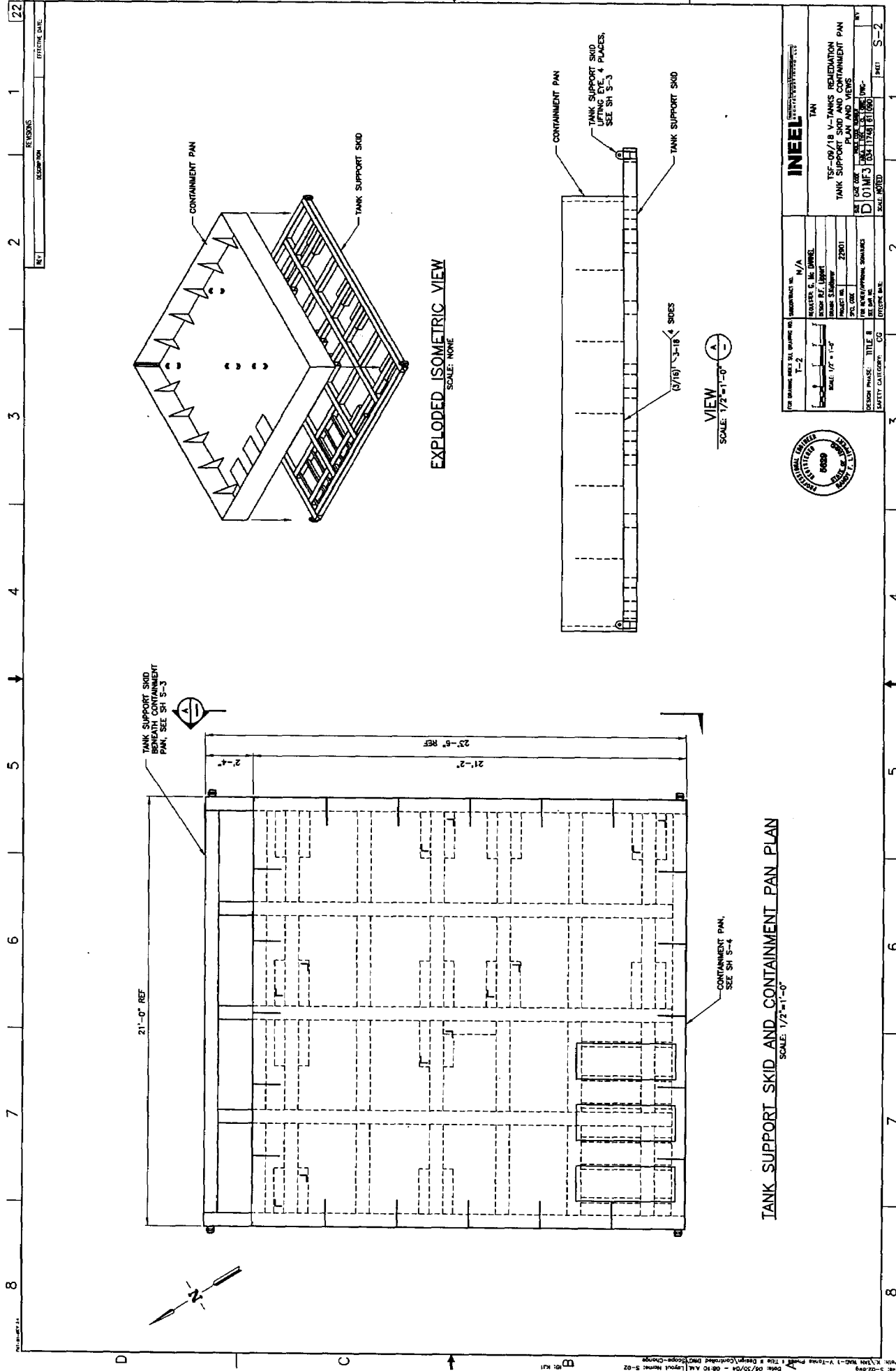

REV	REVISION	DATE
22		

FOR DRAWING FILE NUMBER	T-2
REVISION NO.	N/A
DESIGNED BY	W. J. LUKAS
DRAWN BY	W. J. LUKAS
CHECKED BY	Z. K. J.
DATE	11/11/83
PROJECT NO.	22001
SCALE	AS SHOWN
PROJECT	TSF-09/18 V-TANKS REMEDIATION
DESCRIPTION	TANK SUPPORT SKID AND CONTAINMENT PAN
PROJECT LOCATION	DOUGLASS
PROJECT NUMBER	D 01M3
PROJECT DATE	11/11/83
PROJECT DRAWN BY	W. J. LUKAS
PROJECT CHECKED BY	Z. K. J.
PROJECT DATE	11/11/83
PROJECT SCALE	AS SHOWN
PROJECT SHEET	S-2



INTEL

TSF-09/18 V-TANKS REMEDIATION
TANK SUPPORT SKID AND CONTAINMENT PAN

SCALE: 1/2"=1'-0"

SCALE: NONE

SCALE: 1/2"=1'-0"

SCALE: 1/2"=1'-0"

EDF-5017 136/138

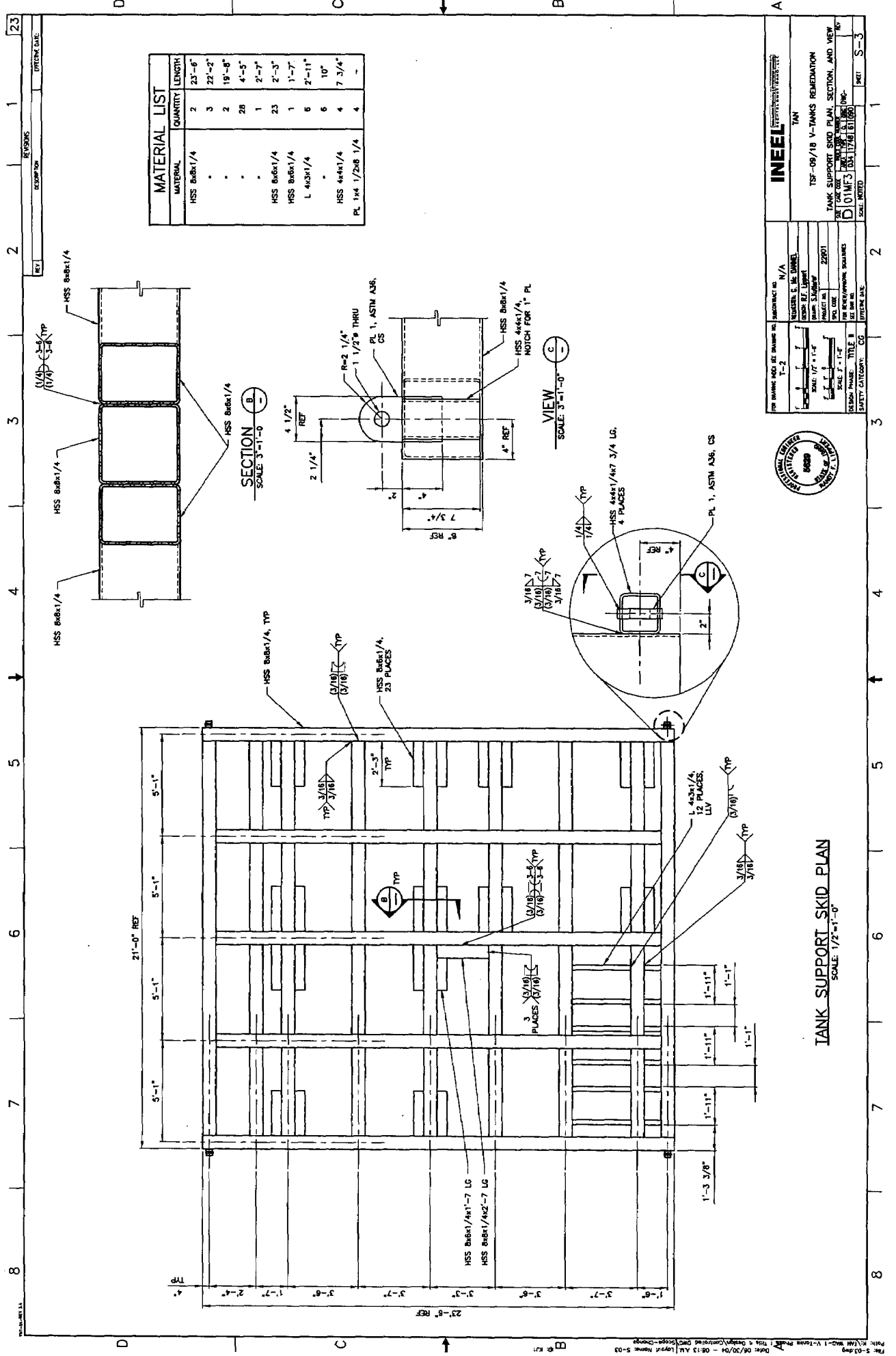

MATERIAL	QUANTITY	LENGTH
HSS 8x8x1/4	2	23'-6"
.	3	22'-2"
.	2	19'-8"
.	28	4'-5"
.	1	2'-7"
HSS 8x8x1/4	23	2'-3"
HSS 8x8x1/4	1	1'-7"
L 4x3x1/4	6	2'-11"
.	6	10"
HSS 4x4x1/4	4	7 3/4"
PL 1x4 1/2x8 1/4	4	-

INEEL
INTEGRATED NEUTRON ELECTRONICS LABORATORY

TAN
TSF-09/18 V-TANKS REMEDIATION
TANK SUPPORT SKID PLAN, SECTION, AND VIEW

DESIGNER: J. M. DUNN
CHECKER: J. M. DUNN
DATE: 01/13/03
SCALE: 1/2" = 1'-0"

FOR BIDDING: 03/17/03
FOR CONSTRUCTION: 03/17/03

PROJECT NO. 136/138
SHEET NO. S-3



TANK SUPPORT SKID PLAN
SCALE: 1/2" = 1'-0"

DF-5017 137/38

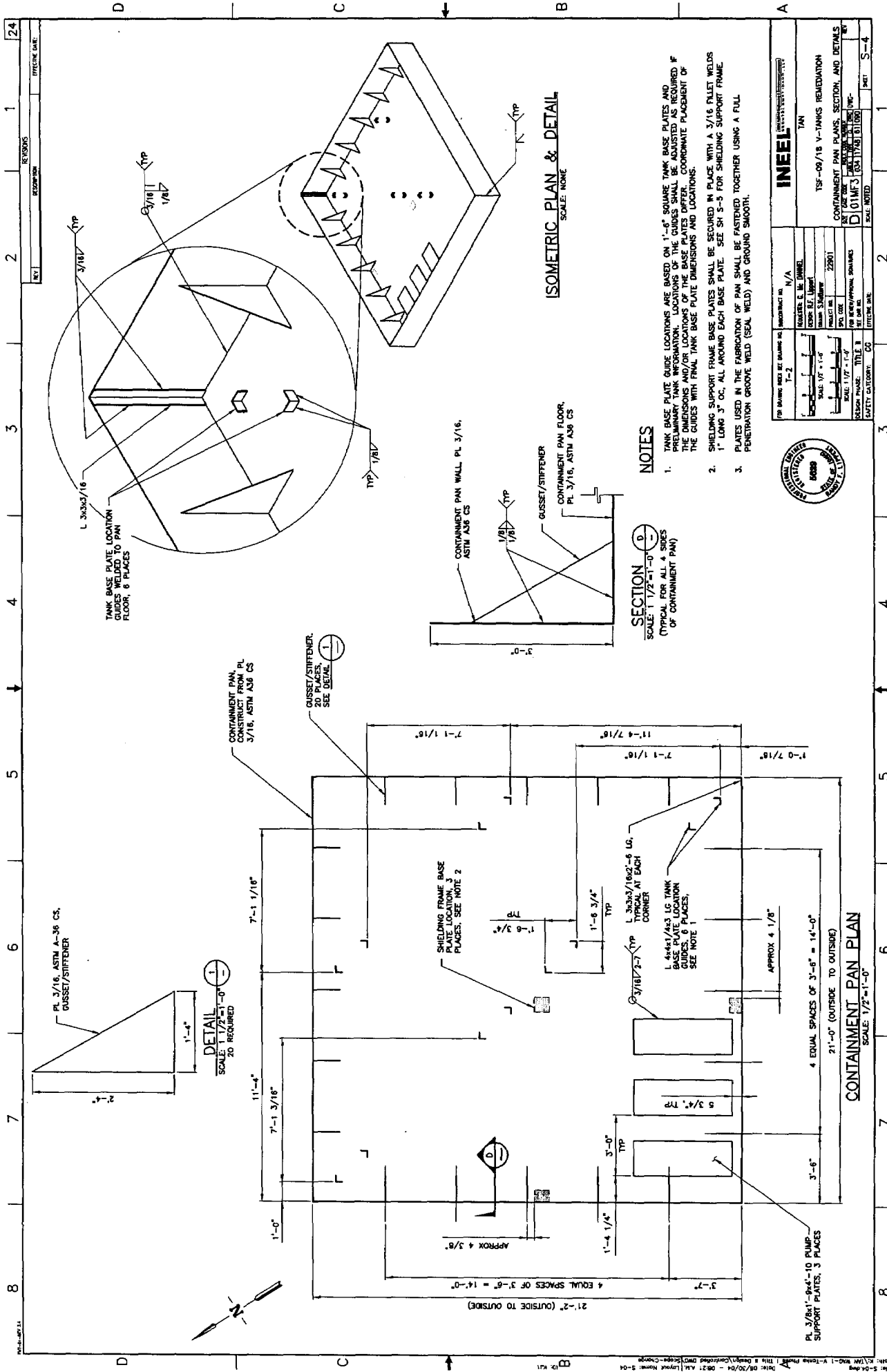

NOTES

1. TANK BASE PLATE GUIDE LOCATIONS ARE BASED ON 1'-0" SQUARE TANK BASE PLATES AND PRELIMINARY TANK INFORMATION. LOCATIONS OF THE GUIDES SHALL BE ADJUSTED AS REQUIRED IF THE DIMENSIONS AND/OR LOCATIONS OF THE TANK BASE PLATES OR THE APPROPRIATE PLACEMENT OF THE GUIDES WITH FINAL TANK BASE PLATE DIMENSIONS AND LOCATIONS.
2. SHIELDING SUPPORT FRAME BASE PLATES SHALL BE SECURED IN PLACE WITH A 3/16 INLET WELDS 1" LONG 3" OC, ALL AROUND EACH BASE PLATE. SEE SH 5-5 FOR SHIELDING SUPPORT FRAME.
3. PLATES USED IN THE FABRICATION OF PAN SHALL BE FASTENED TOGETHER USING A FULL PENETRATION GROOVE WELD (SEAL WELD) AND GRINDING SMOOTH.

SECTION 1-1
SCALE: 1/2" = 1'-0"
(TYPICAL FOR ALL 4 SIDES OF CONTAINMENT PAN)

ISOMETRIC PLAN & DETAIL
SCALE: NONE



FOR DRAWING NEED SEE DRAWING NO.	PROJECT NO.	DATE
T-2	N/A	
DESIGNED BY	CHECKED BY	DATE
W. S. WILSON	E. M. WILSON	2/28/01
DRAWN BY	SCALE	
M. S. WILSON	1/8" = 1'-0"	
DATE	PROJECT NAME	
2/28/01	TANK REMEDIATION	
SCALE	PROJECT NO.	
1/8" = 1'-0"	60889	
DATE	PROJECT NAME	
2/28/01	TANK REMEDIATION	
SCALE	PROJECT NO.	
1/8" = 1'-0"	60889	
DATE	PROJECT NAME	
2/28/01	TANK REMEDIATION	
SCALE	PROJECT NO.	
1/8" = 1'-0"	60889	

CONTAINMENT PAN PLAN
SCALE: 1/2" = 1'-0"

ISOMETRIC PLAN & DETAIL
SCALE: NONE

TANK REMEDIATION
CONTAINMENT PAN PLANS, SECTION AND DETAILS
D 01MFS
SCALE: 1/8" = 1'-0"

DATE: 08/20/04 - 08:21 AM
PROJECT: 60889
DRAWING: T-2

PDF-5017 130/130

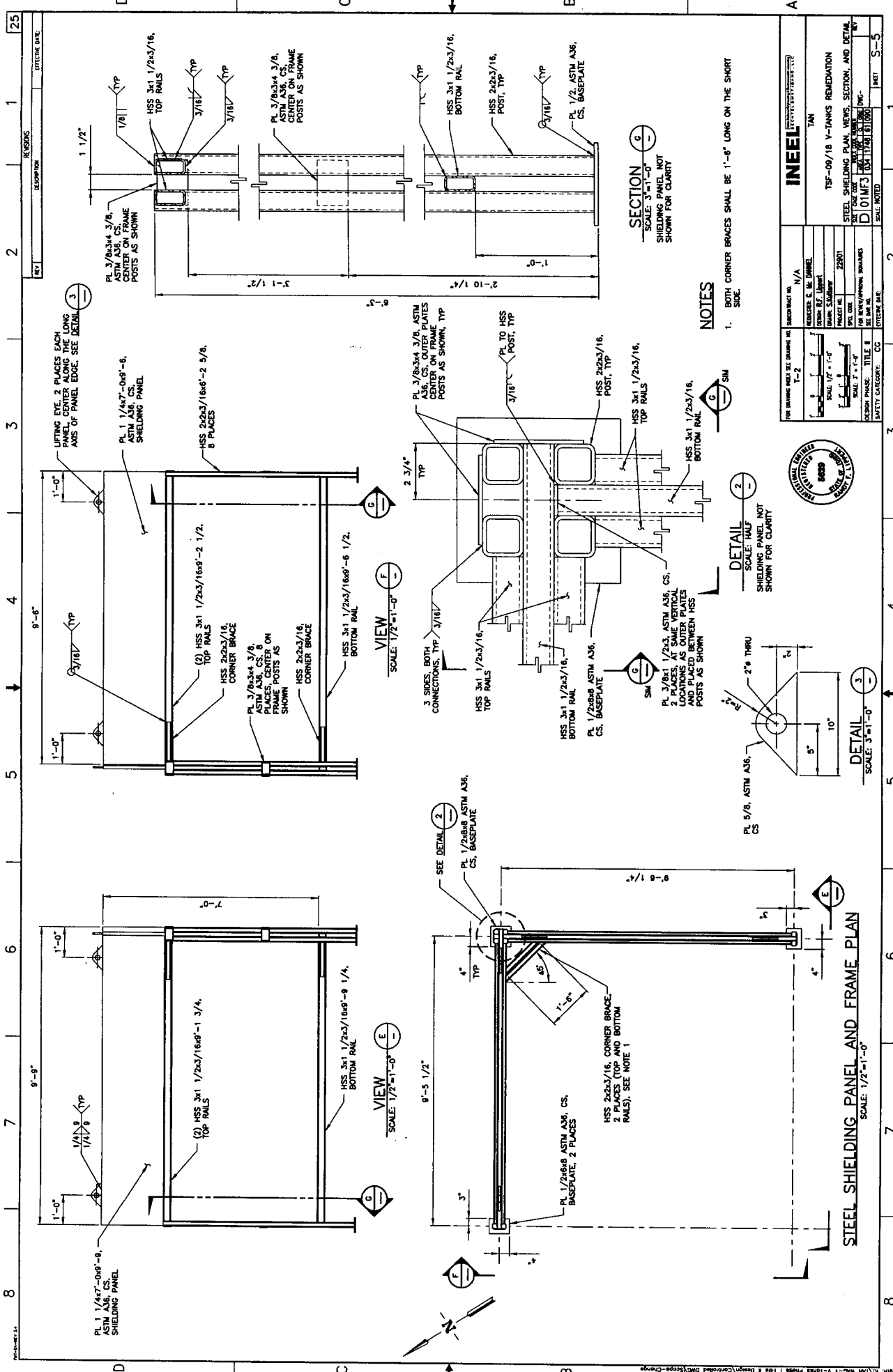

REV. 1 DESCRIPTION REVISIONS DATE

1 1 1/2" 2 3 4 5 6 7 8

1 2 3 4 5 6 7 8

1 2 3 4 5 6 7 8

1 2 3 4 5 6 7 8

1 2 3 4 5 6 7 8

1 2 3 4 5 6 7 8

1 2 3 4 5 6 7 8

1 2 3 4 5 6 7 8

1 2 3 4 5 6 7 8

1 2 3 4 5 6 7 8

1 2 3 4 5 6 7 8

1 2 3 4 5 6 7 8

1 2 3 4 5 6 7 8

1 2 3 4 5 6 7 8

1 2 3 4 5 6 7 8

1 2 3 4 5 6 7 8

1 2 3 4 5 6 7 8

1 2 3 4 5 6 7 8

1 2 3 4 5 6 7 8

1 2 3 4 5 6 7 8

1 2 3 4 5 6 7 8

1 2 3 4 5 6 7 8

1 2 3 4 5 6 7 8

1 2 3 4 5 6 7 8

1 2 3 4 5 6 7 8

1 2 3 4 5 6 7 8

1 2 3 4 5 6 7 8

1 2 3 4 5 6 7 8

1 2 3 4 5 6 7 8

1 2 3 4 5 6 7 8

1 2 3 4 5 6 7 8

1 2 3 4 5 6 7 8

1 2 3 4 5 6 7 8

1 2 3 4 5 6 7 8

1 2 3 4 5 6 7 8

1 2 3 4 5 6 7 8

1 2 3 4 5 6 7 8

1 2 3 4 5 6 7 8

STEEL SHIELDING PANEL AND FRAME PLAN
SCALE: 1/2"=1'-0"

SECTION
SCALE: 3/4"=1'-0"
SHIELDING PANEL NOT SHOWN FOR CLARITY

NOTES

- BOTH CORNER BRACES SHALL BE 1'-6" LONG ON THE SHORT SIDE.

DETAIL
SCALE: 1/2"=1'-0"
SHIELDING PANEL NOT SHOWN FOR CLARITY

DETAIL
SCALE: 3/4"=1'-0"



PROJECT NO.	22901
DATE	03/11/2010
SCALE	AS SHOWN
PROJECT NAME	TSF-09/18 V-TANKS REMEDIATION
CLIENT	DOE
DESIGNER	INEEL
CHECKER	INEEL
DATE PLOTTED	03/11/2010 8:10:00
SCALE	AS SHOWN
PROJECT NO.	22901
DATE	03/11/2010
SCALE	AS SHOWN
PROJECT NAME	TSF-09/18 V-TANKS REMEDIATION
CLIENT	DOE
DESIGNER	INEEL
CHECKER	INEEL
DATE PLOTTED	03/11/2010 8:10:00
SCALE	AS SHOWN