



Report No: SYBH(E)123092007EB-1
FCC ID: QISE170

**FCC TEST REPORT OF
HSPA USB STICK
M/N: E170**

Oct. 23, 2007

Reliability Laboratory of Huawei Technologies Co., Ltd.

All Right Reserved

Notice

1.	The laboratory has obtained the accreditation of China National Accreditation Committee for Laboratories (CNAL), and accreditation number: L0310.
2.	The laboratory has obtained the accreditation of THE AMERICAN ASSOCIATION FOR LABORATORY ACCREDITATION (A2LA), and Accreditation Council Certificate Number: 2174.01.
3.	The laboratory has been listed on the US Federal Communications Commission list of test facilities recognized to perform electromagnetic emissions measurements. The site recognition number is 97456.
4.	The laboratory also has been listed by the VCCI to perform EMC measurements. The accreditation number is C2583, R2364, and T256.
5.	The test report is invalid if not marked with "exclusive stamp for the test report".
6.	Any copy of the test report is invalid if not re-marked with the "exclusive stamp for the test report".
7.	The test report is invalid if not marked with the stamps or the signatures of the persons responsible for performing, revising and approving the test report.
8.	The test report is invalid if there is any evidence of erasure and/or falsification.
9.	If there is any dissidence for the test report, please file objection to the test centre within 15 days from the date of receiving the test report.
10.	Normally, the test report is only responsible for the samples that have undergone the test.
11.	Context of the test report cannot be used partially or in full for publicity and/or promotional purposes without previous written approval of the laboratory.

Contents

1	<u>Summary</u>	5
2	<u>Product Description</u>	6
2.1	PRODUCTION INFORMATION	6
2.2	MODIFICATION INFORMATION.....	6
3	<u>Test Site Description</u>	7
3.1	TESTING PERIOD	7
3.2	GENERAL SET UP DESCRIPTION	7
4	<u>Product Description</u>	8
4.1	TECHNICAL CHARACTERISTICS	8
4.2	EUT IDENTIFICATION LIST	10
5	<u>Main Test Instruments</u>	11
6	<u>Transmitter Measurements</u>	12
6.1	EFFECTIVE RADIATED POWER OF TRANSMITTER (ERP).....	12
6.2	CONDUCTED POWER OF TRANSMITTER.....	16
6.3	MODULATION CHARACTERISTICS	18
6.4	OCCUPIED BANDWIDTH.....	20
6.5	BAND EDGES COMPLIANCE	22
6.6	SPURIOUS EMISSION AT ANTENNA TERMINAL	24
6.7	FREQUENCY STABILITY	25
7	<u>System Measurement Uncertainty</u>	30
8	<u>Appendices</u>	31

1 Summary

The table below summarizes the measurements and results for the HUAWEI E170 USB STICK. Detailed results and descriptions are shown in the following pages.

Table 1 Summary of results

FCC Measurement Specification	FCC Limits Part(s)	Description	Result
2.1046	22.913	Effective Radiated Power of Transmitter	PASS
2.1046	22.913	Conducted Power of Transmitter	PASS
2.1047		Modulation Characteristics	PASS
2.1049		Occupied Bandwidth	PASS
2.1051	22.917	Band Edges compliance	PASS
2.1051	22.917	Spurious Emission at Antenna Terminal	PASS
2.1055	22.355	Frequency Stability	PASS

2 Product Description

2.1 Production Information

2.1.1 General Description

HUAWEI E170 USB Stick is subscriber equipment in the GSM system. The frequency band is 850M. The E170 implements such functions as RF signal receiving / Transmitting, EDGE/GPRS/GSM protocol processing and data service etc. Externally it provides USB interface (to connect to the notebook etc.), USIM card interface. It has an internal antenna. E170 uses Qualcomm MSM7200 chipset and Zero-IF technologies.

2.1.2 Support function and Service

The HUAWEI E170 USB STICK support the function and service as follows:

Table 2 Service and Test mode List

Service Name	Characteristic	Corresponding Test Mode	Note
Data	Modulation: GMSK	TM1	GPRS/GSM
Data	Modulation: 8PSK	TM2	EDGE

Note: * The specified GPRS test conditions & settings are defined in 3GPP TS51.010 V5.4.0 and the EDGE test conditions & settings are defined in 3GPP TS51.010 V5.4.0.

2.2 Modification Information

For original equipment, following table is not application.

Table 3 Modification Information

Model Number	Board/Module	Original Version	New Version	Modify Information
Not applicable				

3 Test Site Description

The test site of:

***Huawei Technologies Co. Ltd.
P.O. Box 518129
Huawei base, bantian,
Longgang District, Shenzhen, China***

The test site description has been submitted to  and registration granted under the registration number **97456** on April 20, 2006. The test site has been accredited by



and the accredited number is **2174.01** in Jan of 2006.

3.1 Testing Period

The test have been performed during the period of

Aug. 01, 2007 –Aug. 16, 2007

3.2 General Set up Description

HUAWEI E170 USB STICK can support GPRS/EDGE mode and 850M Band. During this measurement, the HUAWEI E170 USB STICK just works in GPRS/EDGE mode and 850M Band.

TM1: GPRS/GSM Mode with GMSK Modulation

TM2: EDGE Mode with 8PSK Modulation

4 Product Description

4.1 Technical Characteristics

4.1.1 Frequency Range

Table 4 Frequency Range

Uplink band:	824 to 849 MHz
Downlink band:	869 to 894 MHz

4.1.2 Channel Spacing / Separation

Table 5 Channel Spacing / Separation

	EDGE/GPRS/GSM
Channel spacing	200k Hz
Channel separation:	200k Hz

4.1.3 Type of Emission

Table 6 Type of Emission

	EDGE/GPRS/GSM
Emission Designation:	300kGXW

According to CFR 47 (FCC) part 2, subpart C, section 2.201 and 2.202



4.1.4 Environmental Requirements

Table 7 Environmental Requirements

Minimum temperature:	- 10 °C
Maximum temperature:	+ 55 °C
Relative Humidity:	5%-95%RH

4.1.5 Power Source

Table 8 Power Source

DC voltage nominal:	 5.0V; Supplied by USB port of notebook
DC voltage range	 4.5-5.5V
DC current maximal:	750mA

4.1.6 Tune-up Procedure

According to CFR (FCC) part 2, subpart 2, section 2.1033(c) (9).

Please reference the document Tune-up Procedure in TCF.

4.1.7 Applied DC Voltages and Currents

According to CFR (FCC) part 2, subpart 2, section 2.1033(c) (8).

The voltage and current in the final RF stage is:

Table 9 Applied DC Voltages and Currents

Voltage:	 2.85V
Current:	150mA According to CFR (FCC) part 2, subpart 2, section 2.1033(c) (8)

4.2 EUT Identification List

4.2.1 Board Information

Table 10 Board Information

850MHz HUAWEI E170 USB STICK		
E170		
Board and Module		
Equipment Designation / Description	Serial Number	Remarks
MAINBOARD	EV01AA1792800010	CD96TCPU

4.2.2 Adapter Technical Data

No Applicable.

4.2.3 Battery Technical Data

No Applicable.

4.2.4 FCC Identification

Grantee Code: QIS
 Product Code: E170
 FCC Identification: QISE170

5 Main Test Instruments

Table 11 Main Test Equipments

Equipment Description	Manufacturer	Model	Serial Number	Calibrated until (MM.DD.YYYY)
3m Semi Anechoic Chamber	S+M	N/A	N/A	12.24.2007
3m Full Anechoic Chamber	S+M	N/A	N/A	12.05.2007
Signal Analyzer	R&S	FSQ 26	100266	07.18.2008
Test Receiver Display Unit	R&S	ESMI 804.8932.52	829214/011	07.30.2008
Test Receiver RF Unit	R&S	ESMI 1032.5640.53	829550/008	07.30.2008
Receiver	R&S	ESIB 26	100318	08.17.2008
Receiver	R&S	ESCS30	830245/018	07.30.2008
Pre-Amplifier	Agilent	8447D	2944A10146	07.30.2008
Pre-Amplifier	Agilent	83017A	3950M00246	07.03.2008
Loop Antenna	Schwarzbeck	FMZB1516	1516115	08.08.2008
BiLog Antenna	Schaffner	CBL 6112B	2536	08.30.2008
Horn Antenna	ETS-Lindgren	3117	00062533	09.14.2008
Horn Antenna	ETS-Lindgren	3117	00062549	09.14.2008
Horn Antenna	ETS-Lindgren	3116	00031541	07.15.2008
Dipole	Schwarzbeck	D69250-UHAP/D69250-VHAP	979/917	08.28.2008
Signal Generator	R&S	SMT06	830264/009	09.29.2007
Signal Generator	R&S	SMR 40	100325	12.09.2007
Power Supply	Keithley	2306	1045337	07.20.2008
Climate Chamber	WEISS	ACS-1	3604040034	08.24.2008
Universal Radio Communication Tester	R&S	CMU200	108035	07.04.2008
Wireless communication test set	Agilent	8960	GB43461081	10.24.2007

6 Transmitter Measurements

6.1 Effective Radiated Power of Transmitter (ERP)

6.1.1 Test Conditions

Table 12 Test Conditions

Preconditioning:	0.5 hour
Measured at:	enclosure
Ambient temperature:	25
Relative humidity:	55%
Test Configurations:	TM1/TM2 at frequency Bottom、 Middle、 Top

6.1.2 Test Specifications and Limits

6.1.2.1 Specification

CFR 47 (FCC) part 2.1046 and part 22.913

6.1.2.2 Supporting Standards

Table 13 Supporting Standards:

ANSI/TIA-603-C:2004	Land Mobile FM or PM Communications Equipment Measurement and Performance Standards
3GPP TS51.010 V6.1.0:2005	Digital cellular telecommunications system Mobile Station (MS) conformance specification;

6.1.2.3 Limits

Compliance with part 22.913, mobile/portable stations are limited to 7 watts ERP peak power.
 $W \text{ (dBm)} = 10 \cdot \log(W_{\text{in mWs}})$.

Table 14 Limits

Maximum Output Power (Watts)	< 7 Watts
Maximum Output Power (dBm)	< 38.5 dBm

6.1.3 Test Method and Setup

- For transmitters other than single sideband, independent sideband and controlled carrier radiotelephone, ERP shall be measured when the transmitter is adjusted in accordance with the tune-up procedure to give the values of current and voltage on the circuit elements specified in 2.1033(c)(8). Connect the HUAWEI E170 USB STICK to the wireless communication tester CMU200 via the air interface. The band is set as 850M.
- Test the Radiated maximum output power by the CMU200 received from test antenna.
- Use substitution method to verify the maximum output power. The EUT is substituted by a dipole antenna. The dipole is connected to a signal generator. And then adjust the output level of the signal generator to get the same received power recorded in step (b) on Agilent 8960, and record the power level of Signal Generator. Of course, the cable loss at the test frequency should be compensated.

Test setup

Step 1: Pre-test

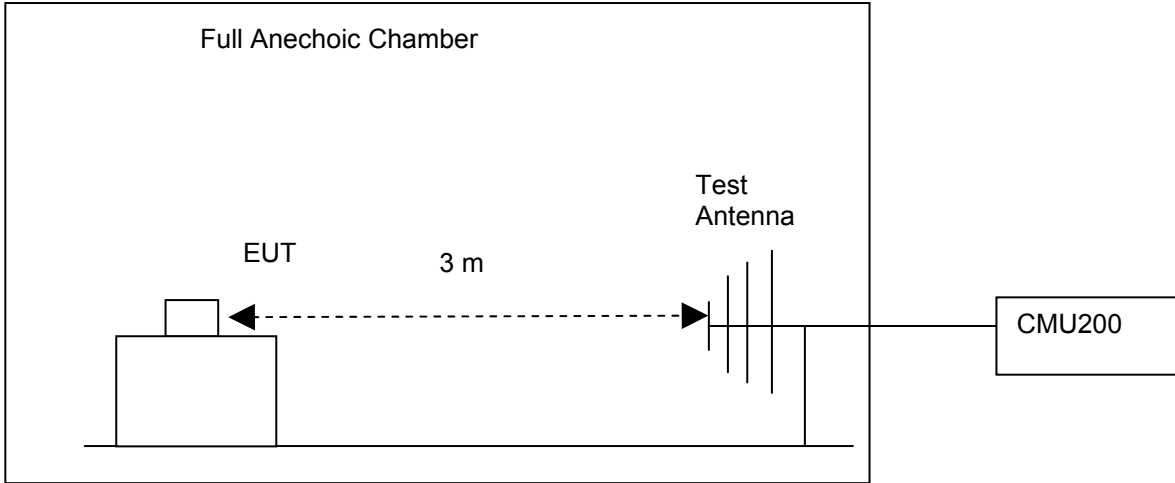

Step 2: Substitution method to verify the maximum ERP

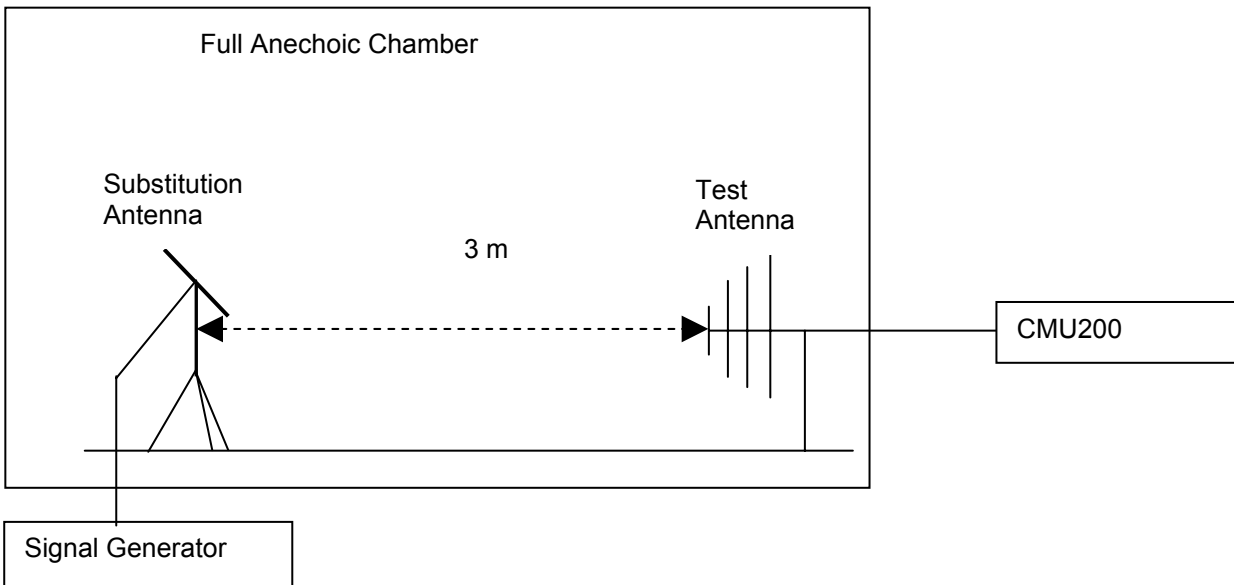

Figure 1. Test Set-up

NOTE: Effective radiated power (ERP) refers to the radiation power output of the EUT, assuming all emissions are radiated from half-wave dipole antennas.

ERP was measured using 3 hosts.

Host 1: BenQ Joy book S72

Host 2: BenQ R55V

Host 3: Acer ZH1

6.1.4 Measurement Results

6.1.4.1 Pre-test Results

Table 15 Pre-test Measurement Results

TEST CONDITIONS		RF Output Power (ERP)					
		Channel128(B) 824.2MHz		Channel192 (M) 837MHz		Channel251(T) 848.8MHz	
		dBm		dBm		dBm	
		Measured	Limit	Measured	Limit	Measured	Limit
TM1(Host 1)	T _{nom} (25 °C) V _{nom} (5.0V)	31.86	38.5	31.82	38.5	31.80	38.5
TM2(Host 1)	T _{nom} (25 °C) V _{nom} (5.0V)	25.96	38.5	25.92	38.5	25.93	38.5
TM1(Host 2)	T _{nom} (25 °C) V _{nom} (5.0V)	31.56	38.5	31.58	38.5	31.57	38.5
TM2(Host 2)	T _{nom} (25 °C) V _{nom} (5.0V)	25.88	38.5	25.78	38.5	25.80	38.5
TM1(Host 3)	T _{nom} (25 °C) V _{nom} (5.0V)	31.54	38.5	31.53	38.5	31.52	38.5
TM2(Host 3)	T _{nom} (25 °C) V _{nom} (5.0V)	25.75	38.5	25.79	38.5	25.70	38.5

6.1.4.2 Substitution Results

Table 16 Substitution Results

Test Mode	Freq. [MHz]	Meas. Level [dBm]	Substitution Antenna Type	SGP [dBm]	Substitution Gain [dBd]	Cable Loss [dB]	Substitution Level (ERP) [dBm]	Limit [dBm]	Result
TM1 (Host 1)	824.2	31.86	Dipole Ant.	35.11	-2.95	0.6	31.56	38.5	Pass
TM1 (Host 1)	837	31.82	Dipole Ant.	35.32	-3.06	0.6	31.66	38.5	Pass
TM1 (Host 1)	848.8	31.80	Dipole Ant.	35.33	-3.11	0.6	31.62	38.5	Pass
TM2 (Host 1)	824.2	25.96	Dipole Ant.	29.01	-2.95	0.6	25.46	38.5	Pass
TM2 (Host 1)	837	25.92	Dipole Ant.	29.13	-3.06	0.6	25.47	38.5	Pass
TM2 (Host 1)	848.8	25.93	Dipole Ant.	29.14	-3.11	0.6	25.43	38.5	Pass
TM1 (Host 2)	824.2	31.56	Dipole Ant.	35.15	-2.95	0.6	31.60	38.5	Pass

TM1 (Host 2)	837	31.58	Dipole Ant.	35.02	-3.06	0.6	31.36	38.5	Pass
TM1 (Host 2)	848.8	31.57	Dipole Ant.	35.13	-3.11	0.6	31.42	38.5	Pass
TM2 (Host 2)	824.2	25.88	Dipole Ant.	28.91	-2.95	0.6	25.36	38.5	Pass
TM2 (Host 2)	837	25.78	Dipole Ant.	29.2	-3.06	0.6	25.54	38.5	Pass
TM2 (Host 2)	848.8	25.80	Dipole Ant.	29.25	-3.11	0.6	25.54	38.5	Pass
TM1 (Host 3)	824.2	31.54	Dipole Ant.	35.11	-2.95	0.6	31.56	38.5	Pass
TM1 (Host 3)	837	31.53	Dipole Ant.	34.92	-3.06	0.6	31.26	38.5	Pass
TM1 (Host 3)	848.8	31.52	Dipole Ant.	35.25	-3.11	0.6	31.54	38.5	Pass
TM2 (Host 3)	824.2	25.75	Dipole Ant.	28.89	-2.95	0.6	25.34	38.5	Pass
TM2 (Host 3)	837	25.79	Dipole Ant.	29.11	-3.06	0.6	25.45	38.5	Pass
TM2 (Host 3)	848.8	25.70	Dipole Ant.	29.16	-3.11	0.6	25.45	38.5	Pass

Note: a, For get the ERP (Efficient Radiated Power) in substitution method, the following formula should take to calculate it,

$$\text{ERP [dBm]} = \text{SGP [dBm]} - \text{Cable Loss [dB]} + \text{Gain [dBd]}$$

NOTE: SGP- Signal Generator Level

b, RBW=10kHz, VBW=300kHz, and integrated by the instrument to 200kHz for TM1 and TM2.

6.1.5 Conclusion

The equipment **PASSED** the requirement of this clause.

6.2 Conducted Power of Transmitter

6.2.1 Test Conditions

Table 17 Test Conditions

Preconditioning:	0.5 hour
Measured at:	Antenna connector
Ambient temperature:	25 °C
Relative humidity:	52 %
Test Configurations:	TM1/TM2 at frequency Bottom、 Middle、 Top

6.2.2 Test Specifications and Limits

6.2.2.1 Specification

CFR 47 (FCC) part 2.1047 and part 22 subpart H

6.2.2.2 Supporting Standards

Table 18 Supporting Standards:

ANSI/TIA-603-C: 2004	Land Mobile FM or PM Communications Equipment Measurement and Performance Standards
3GPP TS51.010 V6.1.0:2005	Digital cellular telecommunications system Mobile Station (MS) conformance specification;

6.2.2.3 Limits

Compliance with part 22.913, in no any case may the peak power of a mobile station transmitter exceed 7 W. The calculated longitude ERP by following formula:

$$\text{ERP(dBm)} = 10 * \log(\text{ERP}_{\text{in watts}}).$$

And for conducted power, we can use Antenna Gain to calculate the limit. So the conducted power:

$$P_{\text{cod}}(\text{dBm}) = \text{ERP}(\text{dBm}) - \text{Gain}(\text{dBd}).$$

and $\text{Gain}(\text{dBd}) = \text{Gain}(\text{dBi}) - 2.15\text{dB}$

Table 19 Limits

Maximum Output Power (Watts)	< 7 Watts (38.5dBm)
Antenna Gain(dBi):	1.5dB
Antenna Gain(dBd):	-0.65dB
Maximum Conducted Output Power (dBm)	< 39.15dBm

6.2.3 Test Method and Setup

(a) For transmitters other than single sideband, independent sideband and controlled carrier radiotelephone, Conducted maximum power shall be measured when the transmitter is adjusted in accordance with the tune-up procedure to give the values of current and voltage on the circuit elements specified in 2.1033(c)(8). Connect the HUAWEI E170 USB Stick to the wireless communication tester CMU200 via the antenna connector. The band class is set as US Cellular.

(b) Test the Conducted maximum output power by the CMU200.

Test setup

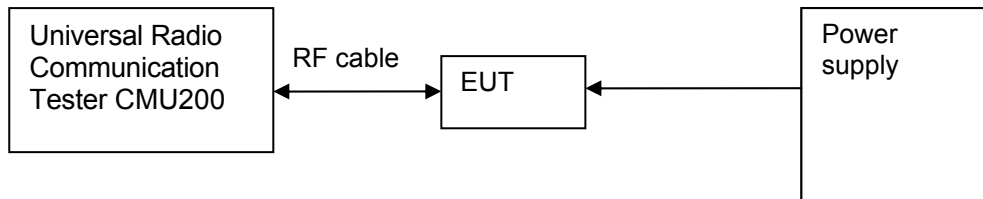

Figure 2. Test Set-up

6.2.4 Measurement Results

Table 20 Measurement Results

TEST CONDITIONS		RF Output Power (Conducted)					
		Channel128(B) 824.2MHz		Channel192 (M) 837MHz		Channel251(T) 848.8MHz	
		dBm		dBm		dBm	
		Measured	Limit	Measured	Limit	Measured	Limit
TM1	T _{nom} (25 °C) V _{nom} (5.0V)	32.32	39.15	32.33	39.15	32.32	39.15
TM2	T _{nom} (25 °C) V _{nom} (5.0V)	26.52	39.15	26.45	39.15	26.55	39.15

6.2.5 Conclusion

The equipment **PASSED** the requirement of this clause.

6.3 Modulation Characteristics

6.3.1 Test Conditions

Table 21 Test Conditions

Preconditioning:	0.5 hour
Measured at:	Antenna connector
Ambient temperature:	25 °C
Relative humidity:	52 %
Test Configurations:	TM1/TM2 at frequency Middle

6.3.2 Test Specifications and Limits

6.3.2.1 Specification

CFR 47 (FCC) part 2.1047 and part 22 subpart H

6.3.2.2 Supporting Standards

Table 22 Supporting Standards:

ANSI/TIA-603-C: 2004	Land Mobile FM or PM Communications Equipment Measurement and Performance Standards
3GPP TS51.010 V6.1.0:2005	Digital cellular telecommunications system Mobile Station (MS) conformance specification;

6.3.2.3 Limits

No specific modulation characteristics requirement limits in part 2.1047 and part 22 subpart H.

Table 23 Limits

Limits	Not applicable
--------	----------------

6.3.3 Test Method and Setup

Connect the HUAWEI E170 USB Stick to Universal Radio Communication Tester CMU200 via the antenna connector. The frequency band is set as 850M; the HUAWEI E170 USB Modem's output is matched with 50 Ω load, test method was according to 3GPP TS 51.010. The waveform quality and constellation of the HUAWEI E170 USB Stick was tested.

Test setup

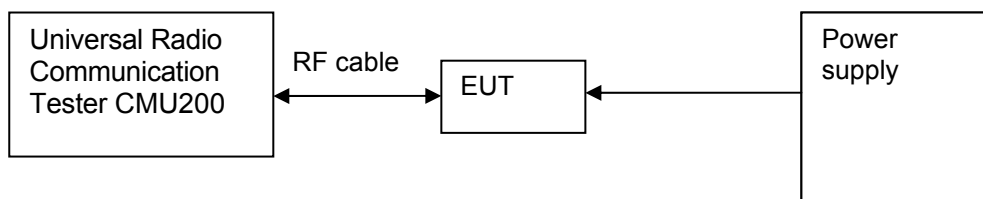

Figure 3. Test Set-up

6.3.4 Measurement Results

Table 24 Measurement Results

		Modulation Characteristic	
TEST CONDITIONS		Channel192(M) 837MHz	
		Measured	
		TM1	TM2
T _{nom} (25 °C)	V _{nom} (5.0V)	Refer to Appendix A	Refer to Appendix A

6.3.5 Conclusion

The equipment **PASSED** the requirement of this clause.

For the measurement results refer to appendix A.

6.4 Occupied Bandwidth

6.4.1 Test Conditions

Table 25 Test Conditions

Preconditioning:	0.5 hour
Measured at:	Antenna connector
Ambient temperature:	25 °C
Relative humidity:	55 %
Test Configurations:	TM1/TM2 at frequency Bottom、 Middle、 Top

6.4.2 Test Specifications and Limits

6.4.2.1 Specification

CFR 47 (FCC) part 2.1049 and part 22 subpart H.

6.4.2.2 Supporting Standards

Table 26 Supporting Standards:

ANSI/TIA-603-C: 2004	Land Mobile FM or PM Communications Equipment Measurement and Performance Standards
3GPP TS51.010 V6.1.0:2005	Digital cellular telecommunications system Mobile Station (MS) conformance specification;

6.4.2.3 Limits

No specific occupied bandwidth requirement in part 22 subpart H, but the occupied bandwidth was defined in part 2.1049: the frequency bandwidth such that, below its lower and above its upper frequency limits, the mean powers radiated are each equal to 0.5 percent of the total mean power radiated by a given emission shall be measured.

Table 27 Limits

Upper /lower frequency limits	0.5% of the mean power
-------------------------------	------------------------

6.4.3 Test Method and Setup

HUAWEI E170 USB Stick was connected to the wireless signal analyzer R&S FSU26 via the one RF connector. The band class is set as 850M; HUAWEI E170 USB Stick was controlled to transmit maximum power. Measure and record the occupied bandwidth of the HUAWEI E170 USB Stick by the R&S FSU26.

The OBW, that is the frequency bandwidth such that, below its lower and above its upper frequency limits, the mean powers radiated are each equal to 0.5 percent of the total mean power radiated by a given emission shall be measured under the following conditions as applicable:

Refer to 47CFR part2.1049 section (g)&(h).

(g) Transmitter in which the modulating base band comprises not more than three independent channels - when modulated by the full complement of signals for which the transmitter is rated. The level of modulation for each channel should be set to that prescribed in rule parts applicable to the

services for which the transmitter is intended. If specific modulation levels are not set forth in the rules, the tests should provide the manufacturer’s maximum rated condition.

(h) Transmitters employing digital modulation techniques - when modulated by an input signal such that its amplitude and symbol rate represent the maximum rated conditions under which the equipment will be operated. The signal shall be applied through any filter networks, pseudorandom generators or other devices required in normal service. Additionally, the occupied bandwidth shall be shown for operation with any devices used for modifying the spectrum when such devices are optional at discretion of the user.

For TM1/TM2 following RBW and VBW are employed:
 Measurement bandwidth (RBW): 3 kHz (Resolution bandwidth)
 Video bandwidth (VBW): 10 kHz

Test Set-up

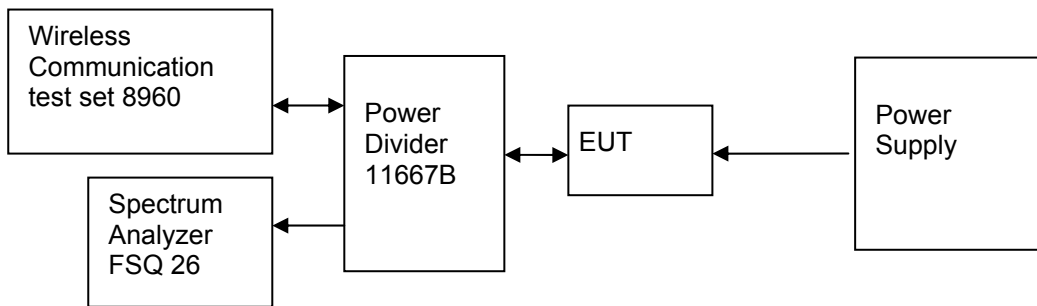

Figure 4. Test Set-up

6.4.4 Measurement Results

Table 28 Measurement Results

TEST CONDITIONS		Occupied Bandwidth					
		Channel128 (B) 824.2MHz		Channel192 (M) 837MHz		Channel251 (T) 848.8MHz	
		Measured (kHz)		Measured (kHz)		Measured (kHz)	
		TM1	TM2	TM1	TM2	TM1	TM2
T _{nom} (25 °C)	99%	243.58	248.39	243.58	241.98	243.58	243.58
V _{nom} (5.0V)							

6.4.5 Conclusion

The equipment **PASSED** the requirement of this clause.
 For the measurement results refer to appendix B.

6.5 Band Edges Compliance

6.5.1 Test Conditions

Table 29 Test Conditions

Preconditioning:	0.5 hour
Measured at:	Antenna connector
Ambient temperature:	25°C
Relative humidity:	55 %
Test Configurations:	TM1/TM2 at frequency Bottom、 Top

6.5.2 Test Specifications and Limits

6.5.2.1 Specification

CFR 47 (FCC) part 2.1051 and part 22.917

6.5.2.2 Supporting Standards

Table 30 Supporting Standards:

ANSI/TIA-603-C: 2004	Land Mobile FM or PM Communications Equipment Measurement and Performance Standards
3GPP TS51.010 V6.1.0:2005	Digital cellular telecommunications system Mobile Station (MS) conformance specification;

6.5.2.3 Limits

Compliance with part 22.917, all spurious emission must be attenuated below the transmitter power by at least $43 + 10 \log_{10} P (W)$. (Whereas P is the rated power of the EUT).

Table 31 Limits

	TM1	TM2
Rated Power:	33 dBm	27 dBm
Required attenuation:	$43 + 10 \log (2) = 46$, 33 dBm - 46 dB	$43 + 10 \log (0.5) = 40$, 27 dBm - 40 dB
Absolute level	- 13 dBm	- 13 dBm

6.5.3 Test Method and Setup

HUAWEI E170 USB Stick was connected to the wireless signal analyzer R&S FSU26 via the one RF connector, the band class is set as 850M. HUAWEI E170 USB Stick was controlled to transmit maximum power. Measure and record band edges compliance of the HUAWEI E170 USB Stick by the R&S FSU26.

In the 1 MHz bands immediately outside and adjacent to the frequency block a resolution bandwidth of at least 1% of the emission bandwidth of the fundamental emission of the transmitter may be employed. According to FCC part22.917.The FCC rules define the fundamental emission as -26dBc bandwidth.

The limit is -13dBm.

For TM1/TM2 following RBW and VBW are employed:
 Measurement bandwidth (RBW): 3 kHz (Resolution bandwidth)
 Video bandwidth (VBW): 10 kHz

Test Set-up

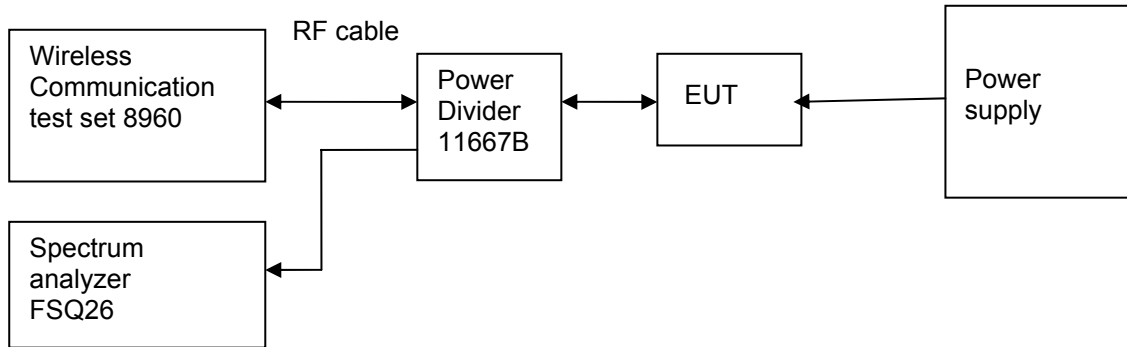

Figure 5. Test Set-up

6.5.4 Measurement Results

Table 32 Measurement Results outside Band Edges-- Single Carrier

Band	Frequency of Band edges [MHz]	Channel Number	Test Mode	Spurious Level measured [dBm]	FCC limit	Result
$T_{nom} (25\text{ }^{\circ}\text{C}), V_{nom} (5.0\text{V})$						
Cellular	824.2	128	TM1	<-13(See appendix C)	- 13 dBm	Pass
	848.8	251	TM1	<-13(See appendix C)	- 13 dBm	Pass
	824.2	128	TM2	<-13(See appendix C)	- 13 dBm	Pass
	848.8	251	TM2	<-13(See appendix C)	- 13 dBm	Pass

6.5.5 Conclusion

The equipment **PASSED** the requirement of this clause.
 For the measurement results refer to appendix C.

6.6 Spurious Emission at Antenna Terminal

6.6.1 Test Conditions

Table 33 Test Conditions

Preconditioning:	0.5 hour
Measured at:	Antenna connector
Ambient temperature:	25°C
Relative humidity:	50 %
Test Configurations:	TM1/TM2 at frequency B、 T

6.6.2 Test Specifications and Limits

6.6.2.1 Specification

CFR 47 (FCC) part 2.1051 and part 22.917

6.6.2.2 Supporting Standards

Table 34 Supporting Standards:

ANSI/TIA-603-C: 2004	Land Mobile FM or PM Communications Equipment Measurement and Performance Standards
3GPP TS51.010 V6.1.0:2005	Recommended GSM/EDGE MS conformance specification

6.6.2.3 Limits

Compliance with part 22.917, all spurious emission must be attenuated below the transmitter power by at least $43 + 10 \log_{10} P$. (Whereas P is the rated power of the EUT).

Table 35 Limits

	TM1	TM2
Rated Power:	33dBm	27 dBm
Required attenuation:	$43 + 10 \log(2) = 46$, 33 dBm - 46 dB	$43 + 10 \log(0.5) = 40$, 27 dBm - 40 dB
Absolute level	- 13 dBm	- 13 dBm

6.6.3 Test Method and Setup

HUAWEI E170 USB Stick was connected to the wireless signal analyzer R&S FSU26 via the one RF connector, the band class is set as 850M. HUAWEI E170 USB Stick was controlled to transmit maximum power. Measure and record the Conducted Spurious Emission of the HUAWEI E170 USB Stick by the R&S FSU26.

According to part 22.917, the defined measurement bandwidth as following:

22.917 (b) Measurement procedure: Compliance with these provisions is based on the use of measurement instrumentation employing a resolution bandwidth of 100 kHz or greater.

Measurement bandwidth (RBW) for 9 kHz up to 150 KHz: 1 kHz;
 Measurement bandwidth (RBW) for 150 kHz up to 30 MHz: 10 kHz;
 Measurement bandwidth (RBW) for 30 MHz up to 1 GHz: 100 kHz;
 Measurement bandwidth (RBW) for 1 GHz up to 12.75 GHz: 1 MHz;

Test Set-up

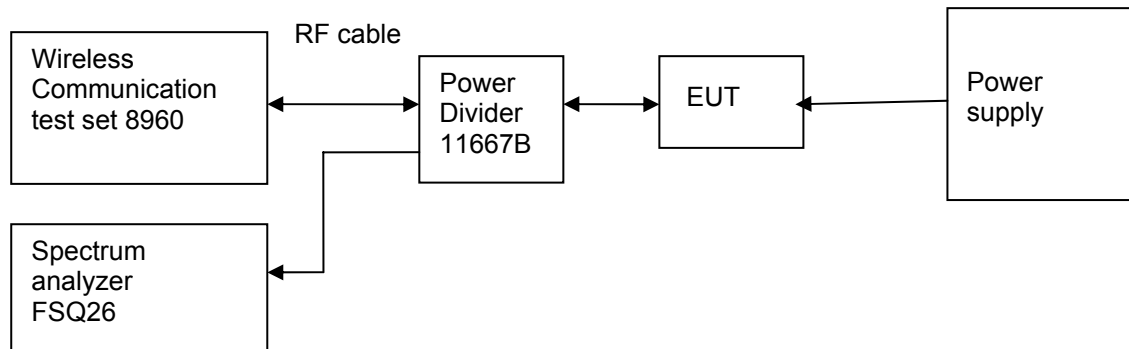

Figure 6. Test Set-up

6.6.4 Measurement Results

Table 36 Measurement Results

Channel Number	Test Mode	Test Range (Frequency)	Output Power [dBm]	Spurious Level measured [dBm]	FCC limit	Result
Channel 128(B)	TM1	9 kHz ~12.75GHz	33	<- 13 dBm (See appendix D)	- 13 dBm	Pass
	TM2	9 kHz ~12.75GHz	27	<- 13 dBm (See appendix D)	- 13 dBm	Pass
Channel 251(T)	TM1	9 kHz ~12.75GHz	33	<- 13 dBm (See appendix D)	- 13 dBm	Pass
	TM2	9 kHz ~12.75GHz	27	<- 13 dBm (See appendix D)	- 13 dBm	Pass

6.6.5 Conclusion

The equipment **PASSED** the requirement of this clause.
 For the measurement results refer to appendix D.

6.7 Frequency Stability

6.7.1 Test Conditions

Table 37 Test Conditions

Preconditioning:	0.5 hour
------------------	----------

Measured at:	Antenna connector
Ambient temperature:	See below
Relative humidity:	55 % at 25 °C
Test Configurations:	TM1/TM2 at frequency M

6.7.2 Test Specifications and Limits

6.7.2.1 Specification

CFR 47 (FCC) part 2.1055 and part 22.355

6.7.2.2 Supporting Standards

Table 38 Supporting Standards:

ANSI/TIA-603-C: 2004	Land Mobile FM or PM Communications Equipment Measurement and Performance Standards
3GPP TS51.010 V6.1.0:2005	Digital cellular telecommunications system Mobile Station (MS) conformance specification;

6.7.2.3 Limits

According to part 22.355, from 821MHz to 896MHz, for mobile device, the carrier frequency of each transmitter in the Public Mobile Services must be maintained within the tolerances 2.5ppm.

6.7.3 Test Method and Setup

The frequency stability shall be measured with variation of ambient temperature as follows:

- (1) From -30 ° to +50 ° centigrade for all equipment except that specified in subparagraphs (2) and (3) of paragraph 2.1055

(b) Frequency measurements shall be made at the extremes of the specified temperature range and at intervals of not more than 10° centigrade through the range. A period of time sufficient to stabilize all of the components of the oscillator circuit at each temperature level shall be allowed prior to frequency measurement. The short-term transient effects on the frequency of the transmitter due to keying (except for broadcast transmitters) and any heating element cycling normally occurring at each ambient temperature level also shall be shown. Only the portion or portions of the transmitter containing the frequency determining and stabilizing circuitry need be subjected to the temperature variation test.

(d) The frequency stability shall be measured with variation of primary supply voltage as follows:

- (1) Vary primary supply voltage from 85 to 115 percent of the nominal value for other than hand carried battery equipment.
- (2) For hand carried, battery powered equipment, reduce primary supply voltage to the battery operating end point, which shall be specified by the manufacturer.
- (3) The supply voltage shall be measured at the input to the cable normally provided with the equipment, or at the power supply terminals if cables are not normally provided. Effects on frequency of transmitter keying (except for broadcast transmitters) and any heating element cycling at the nominal supply voltage and at each extreme also shall be shown.

(e) When deemed necessary, the Commission may require tests of frequency stability under conditions in addition to those specifically set out in paragraphs (a), (b), (c) and (d) of this section. (For example, measurements showing the effect of proximity to large metal objects, or of various types of antennas, may be required for portable equipment.)

Test Set up

Connect the HUAWEI E170 USB Stick to the Wireless Communication test set 8960 via the connector. Then measure the frequency error by the Wireless Communication test set 8960. The EUT's output is

matched with a 50 Ω load.

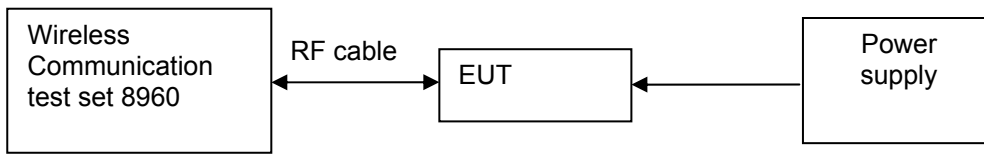

Figure 7. Test Set up

6.7.4 Measurement Results

6.7.4.1 Measurement Results vs. Variation of Temperature

- TM1, 5.0V DC Channel No.192(837.0MHz)

Table 39 Measurement Results vs. Variation of Temperature - GPRS Mode

Temperature	Power (dBm)	Nominal Frequency (MHz)	Measured Frequency Error(Hz)	Result
-30 °C	33	837.0	-32	Pass
-20 °C	33	837.0	-11	Pass
-10 °C	33	837.0	13	Pass
0 °C	33	837.0	22	Pass
+10 °C	33	837.0	32	Pass
+20 °C	33	837.0	16	Pass
+30 °C	33	837.0	18	Pass
+40 °C	33	837.0	43	Pass
+50 °C	33	837.0	-1	Pass

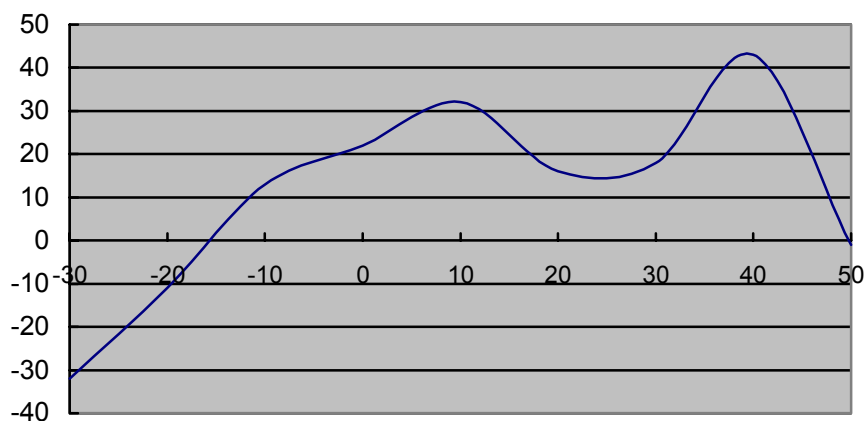

Figure 8. GPRS Mode Test Graph

- TM2, 5.0V DC Channel No.192(837.0MHz)

Table 40 Measurement Results vs. Variation of Temperature - EDGE Mode

Temperature	Power	Nominal	Measured	Result
-------------	-------	---------	----------	--------

	(dBm)	Frequency (MHz)	Frequency Error(Hz)	
-30 °C	27	837.0	18	Pass
-20 °C	27	837.0	16	Pass
-10 °C	27	837.0	32	Pass
0 °C	27	837.0	-10	Pass
+10 °C	27	837.0	-15	Pass
+20 °C	27	837.0	-12	Pass
+30 °C	27	837.0	33	Pass
+40 °C	27	837.0	20	Pass
+50 °C	27	837.0	10	Pass

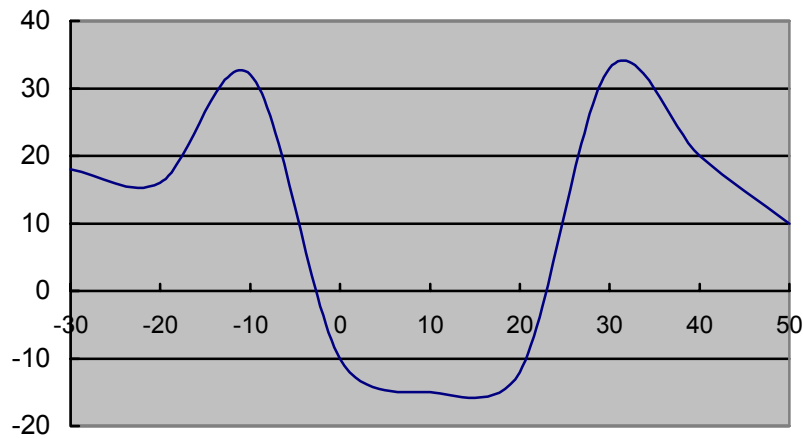

Figure 9. EDGE Mode Test Graph

6.7.4.2 Measurement Results vs. Variation of Voltage

- **TM1, 25 °C ,Channel No. 192(837.0MHz)**

Table 41 Measurement Results vs. Variation of Voltage - GPRS Mode

Voltage	Power (dBm)	Nominal Frequency (MHz)	Measured Frequency Error(Hz)	Result
4.5	33	837.0	10	Pass
5.0	33	837.0	22	Pass
5.0	33	837.0	8	Pass

- **TM2, 25 °C ,Channel No. 192(837.0MHz)**

Table 42 Measurement Results vs. Variation of Voltage - EDGE Mode

Voltage	Power (dBm)	Nominal Frequency	Measured Frequency	Result
---------	-------------	-------------------	--------------------	--------

		(MHz)	Error(Hz)	
4.5	27	837.0	2	Pass
5.0	27	837.0	8	Pass
5.5	27	837.0	20	Pass

6.7.5 Conclusion

The equipment **PASSED** the requirement of this clause.

7 System Measurement Uncertainty

For a 95% confidence level, the measurement expanded uncertainties for defined systems, in accordance with the recommendations of ISO 17025 as following:

Table 43 System Measurement Uncertainty

Items		Extended Uncertainty
Effective Radiated Power of Transmitter	EIRP (dBm)	U=3dB; k=2
Band Width	Magnitude (%)	U = 0.2%; k=2
Band Edge Compliance	Disturbance Power (dBm)	U = 2.0dB; k=2
Conducted Spurious Emission at Antenna Terminal	Disturbance Power (dBm)	U = 2.0dB; k=2
Frequency Stability	Frequency Accuracy(ppm)	U = 0.21ppm; k=2

8 Appendices

Appendix A	Measurement Results Modulation Characteristics	3 pages
Appendix B	Measurement Results Occupied Bandwidth	7 pages
Appendix C	Measurement Results Band Edges	5 pages
Appendix D	Measurement Results Spurious Emission at Antenna Terminal	25 pages

Appendix A

Modulation Characteristics

According to FCC Part 2.1047 & Part22 Subpart H

Channel 192 (TM1:GPRS/GSM)

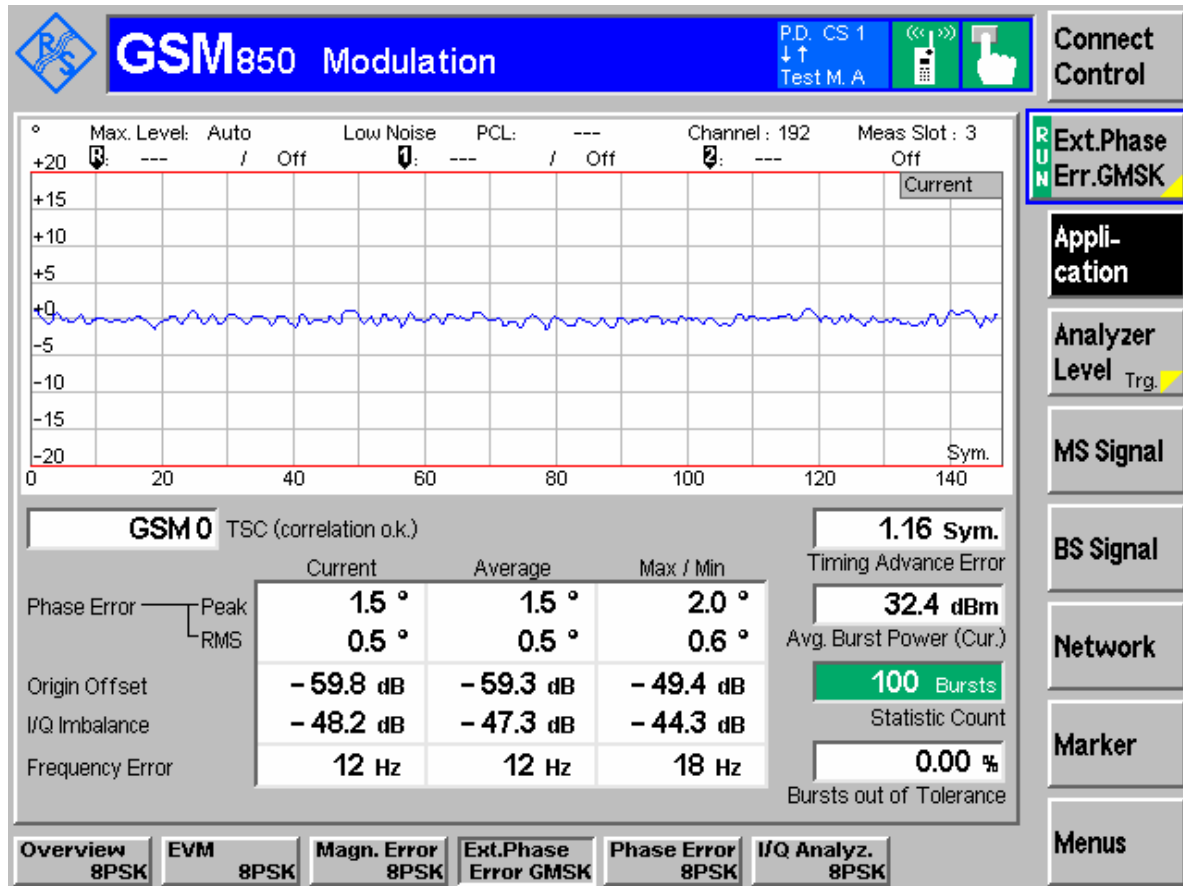

Channel 192 (TM2:EDGE)

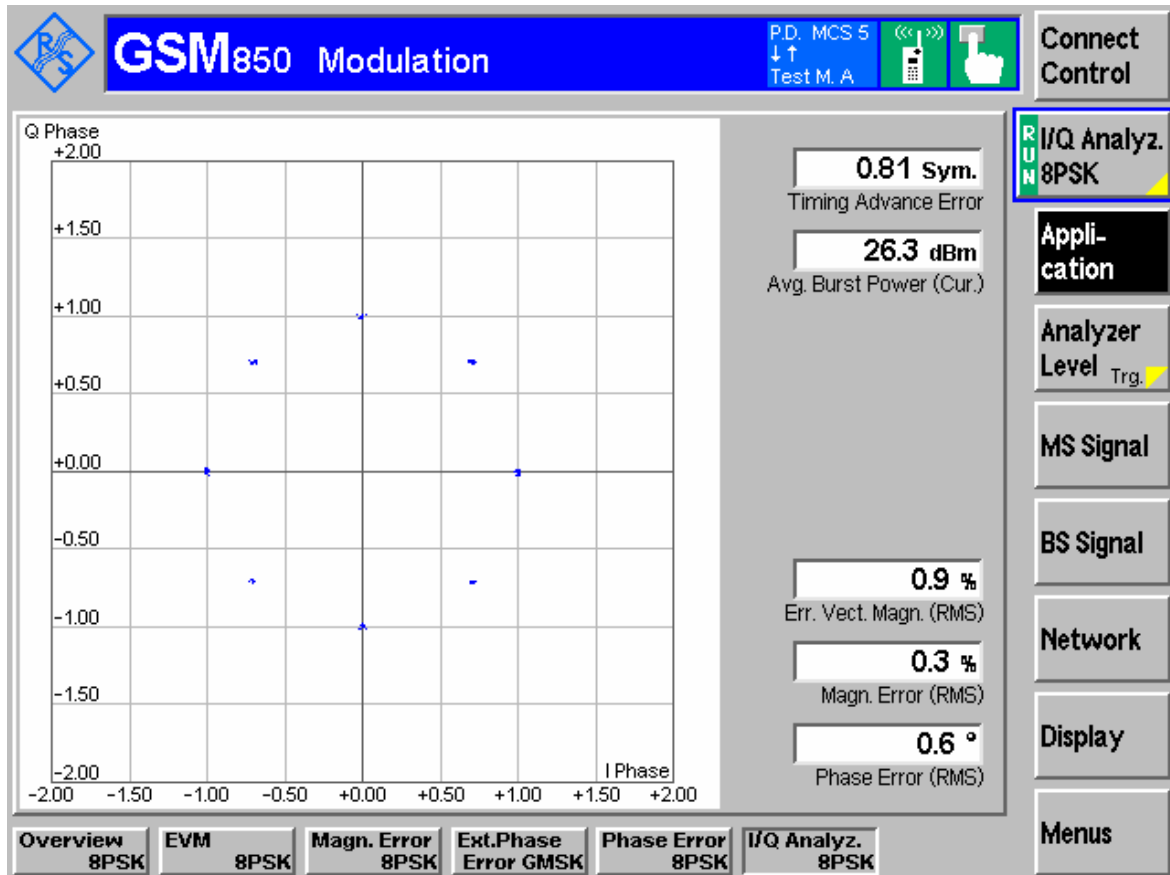

Appendix B

Occupied Bandwidth

According to FCC Part 2.1049 & Part 22 Subpart H

Channel 128 (TM1:GPRS/GSM)



Ref 35 dBm Att 15 dB * RBW 3 kHz * VBW 10 kHz * SWT 115 ms

Marker 1 [T1]

25.37 dBm

824.198397436 MHz

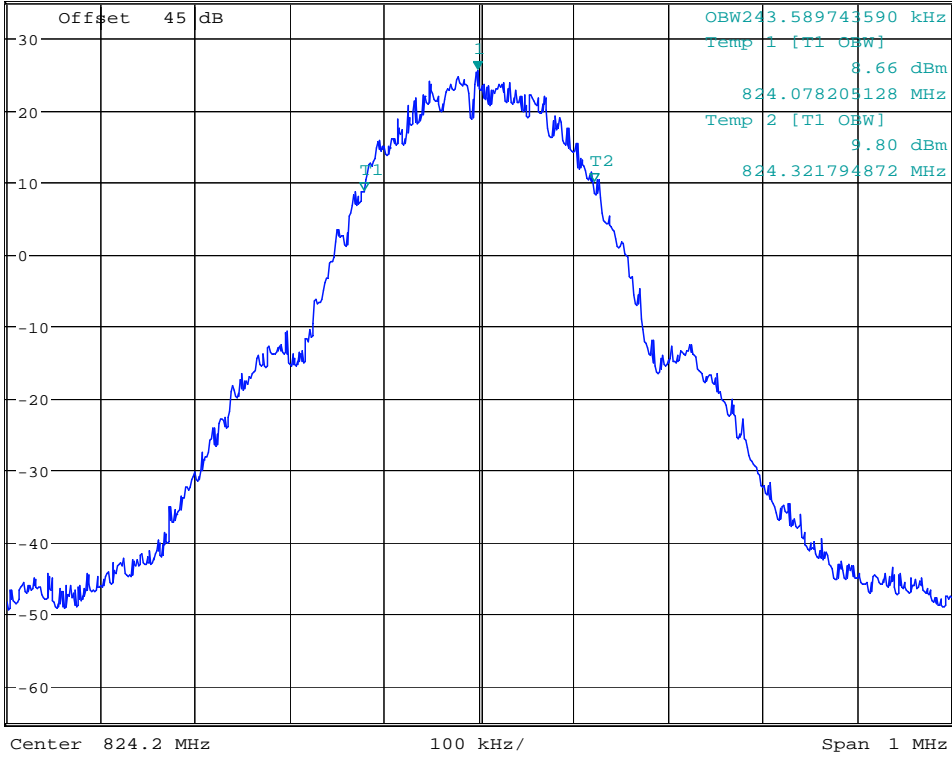

Date: 6.OCT.2007 10:36:17

Channel 192 (TM1:GPRS/GSM)

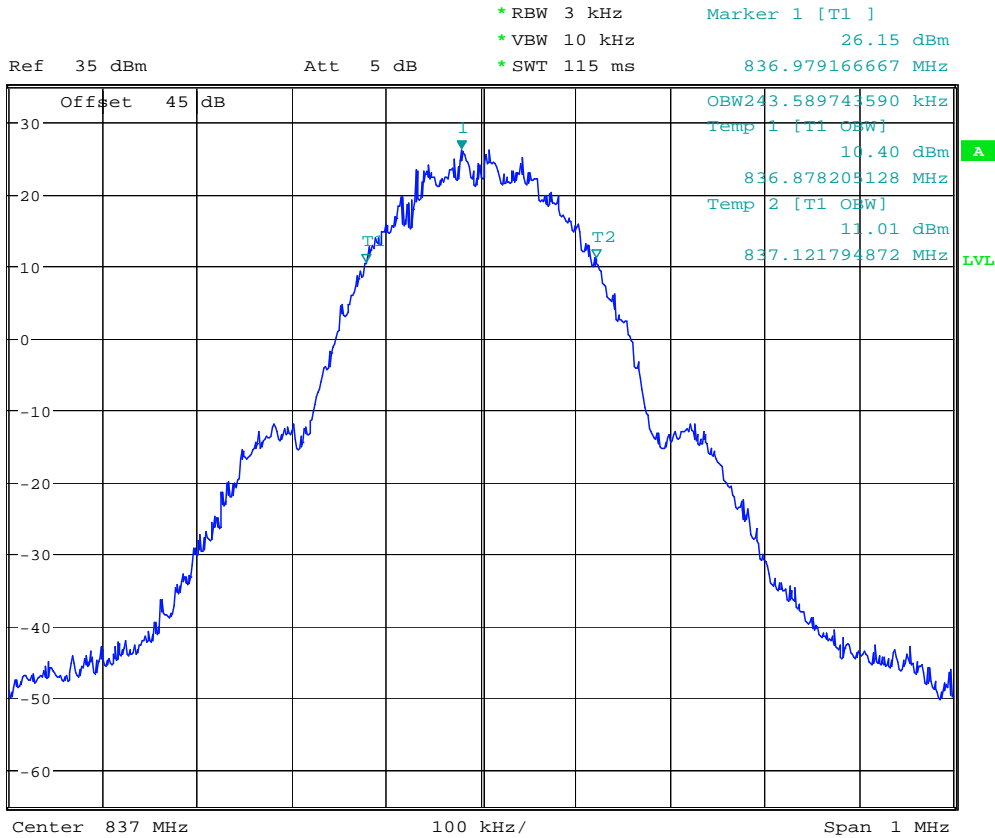

Date: 6.OCT.2007 10:37:51

Channel 251 (TM1:GPRS/GSM)

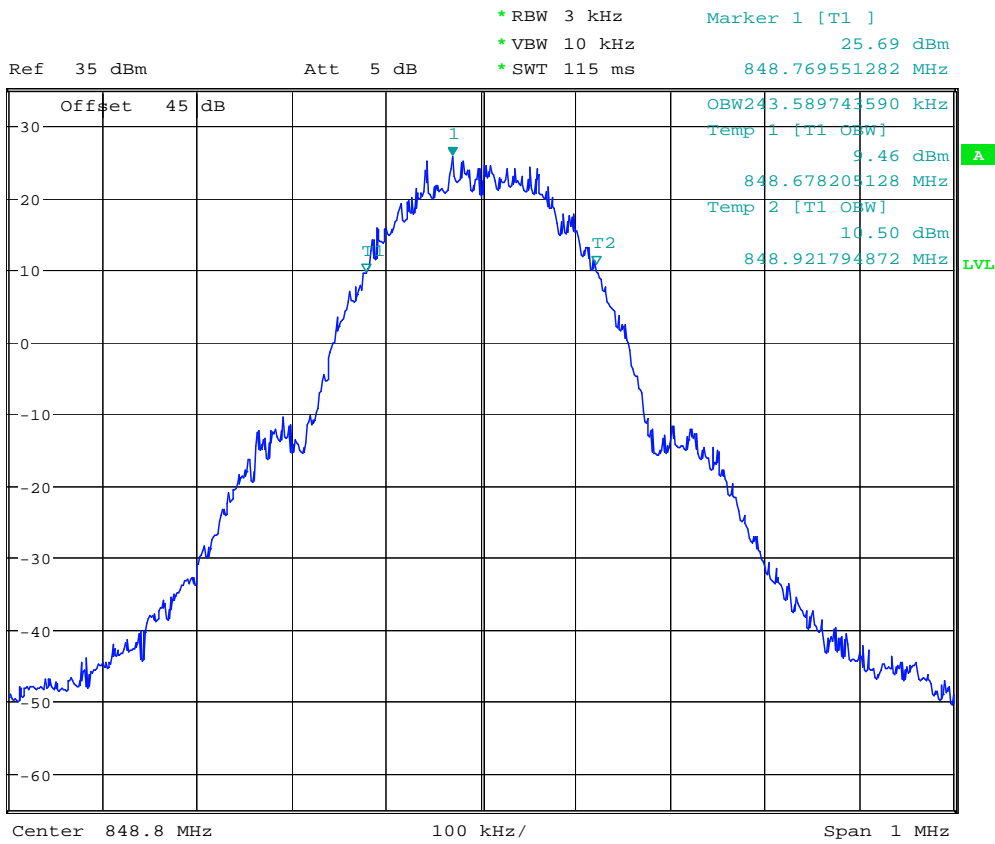

Date: 6.OCT.2007 10:39:12

Channel 251 (TM2:EDGE)



Ref 35 dBm Att 5 dB *RBW 3 kHz *VBW 10 kHz *SWT 115 ms Marker 1 [T1] 18.51 dBm 848.814423077 MHz

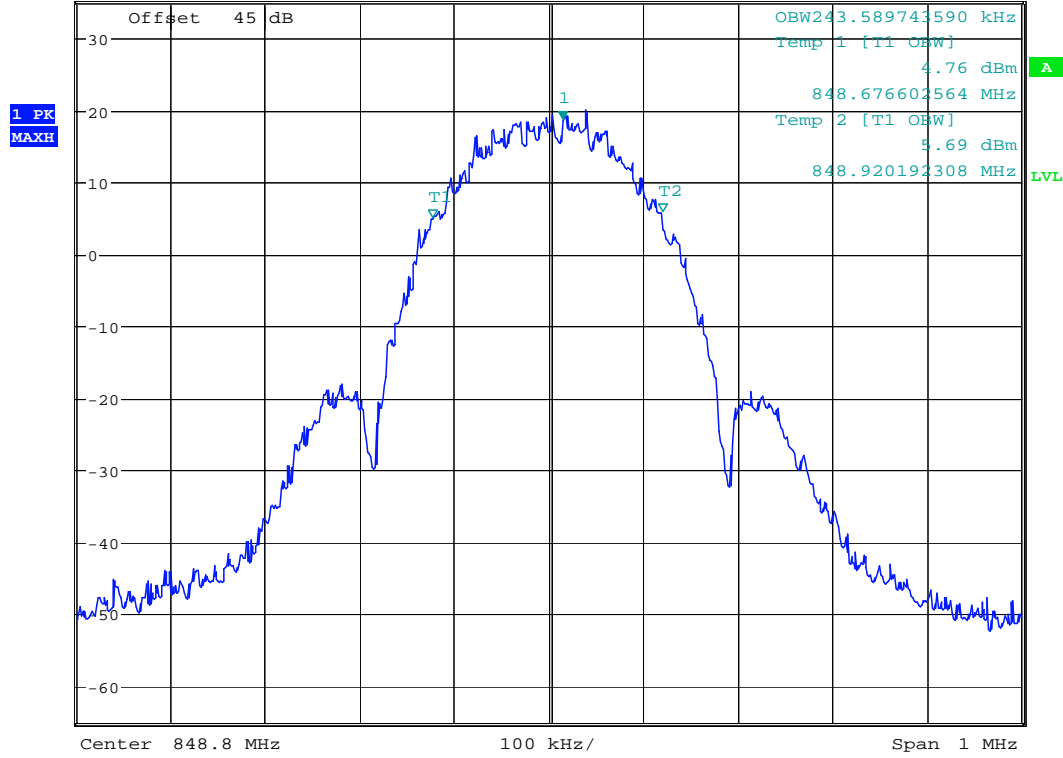

Date: 6.OCT.2007 10:43:40

Appendix C

Band Edges Compliance According to FCC Part 2.1051 & 22.917

TM1:GPRS/GSM

Left Edge

Channel 128

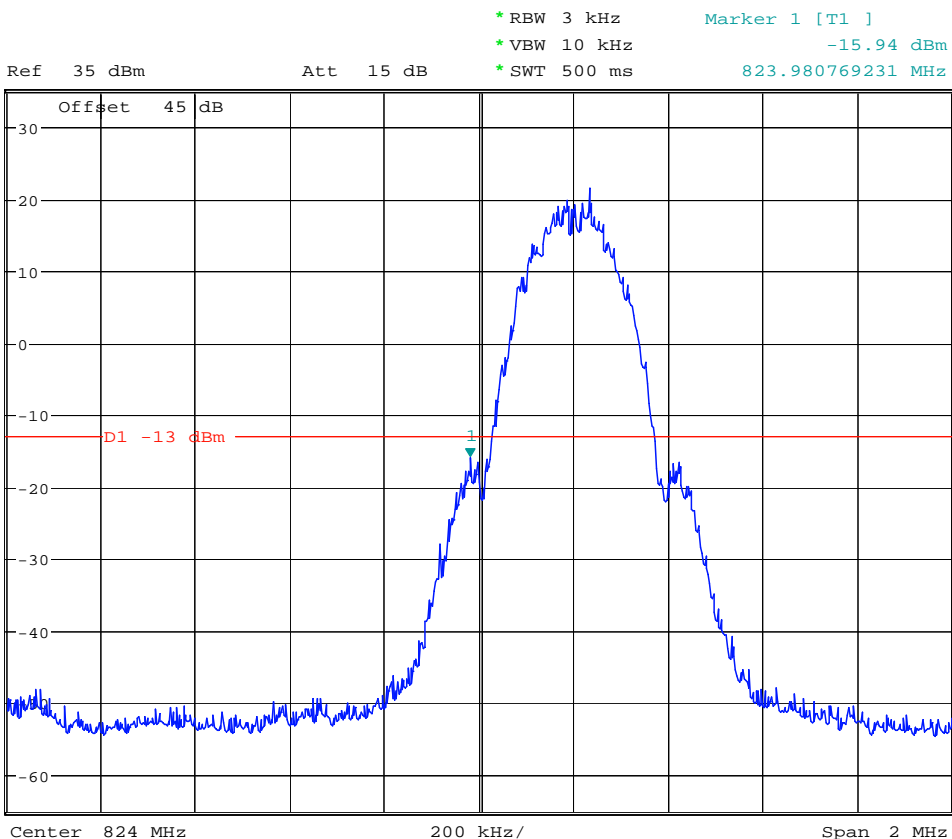

Date: 6.OCT.2007 10:55:00

Right Edge Channel 251



* RBW 3 kHz Marker 1 [T1]
* VBW 10 kHz -15.79 dBm
* SWT 500 ms 849.016025641 MHz

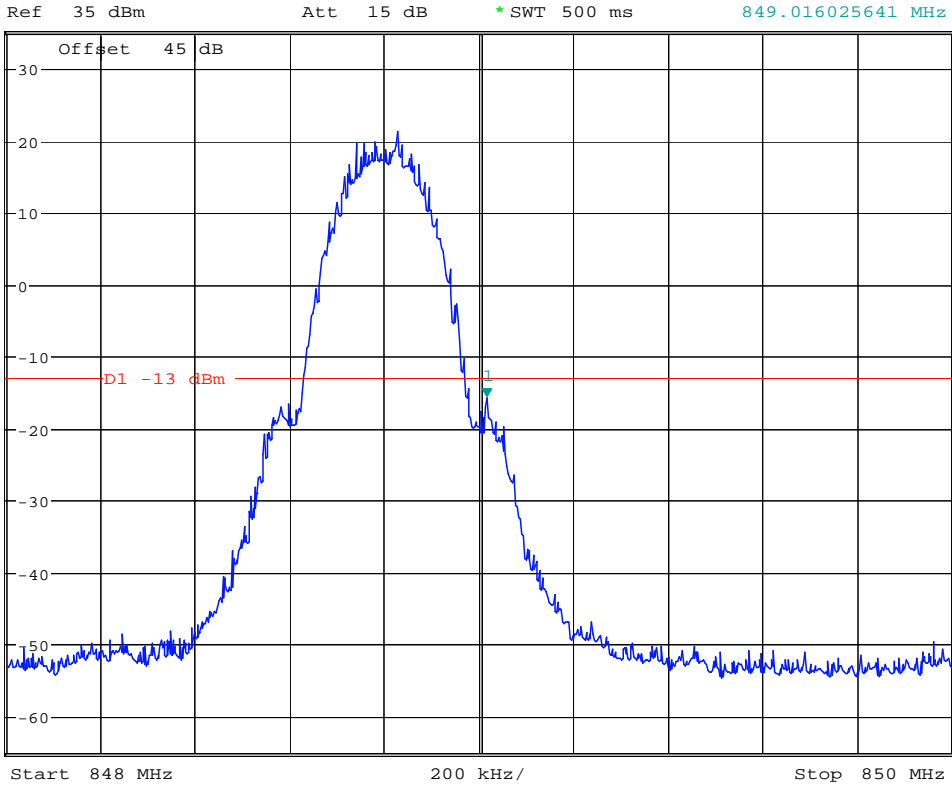

Date: 6.OCT.2007 10:56:51

TM2:EDGE

Left Edge

Channel 128



Ref 35 dBm Att 15 dB *RBW 3 kHz *VBW 10 kHz *SWT 500 ms

Marker 1 [T1] -22.68 dBm 823.987179487 MHz

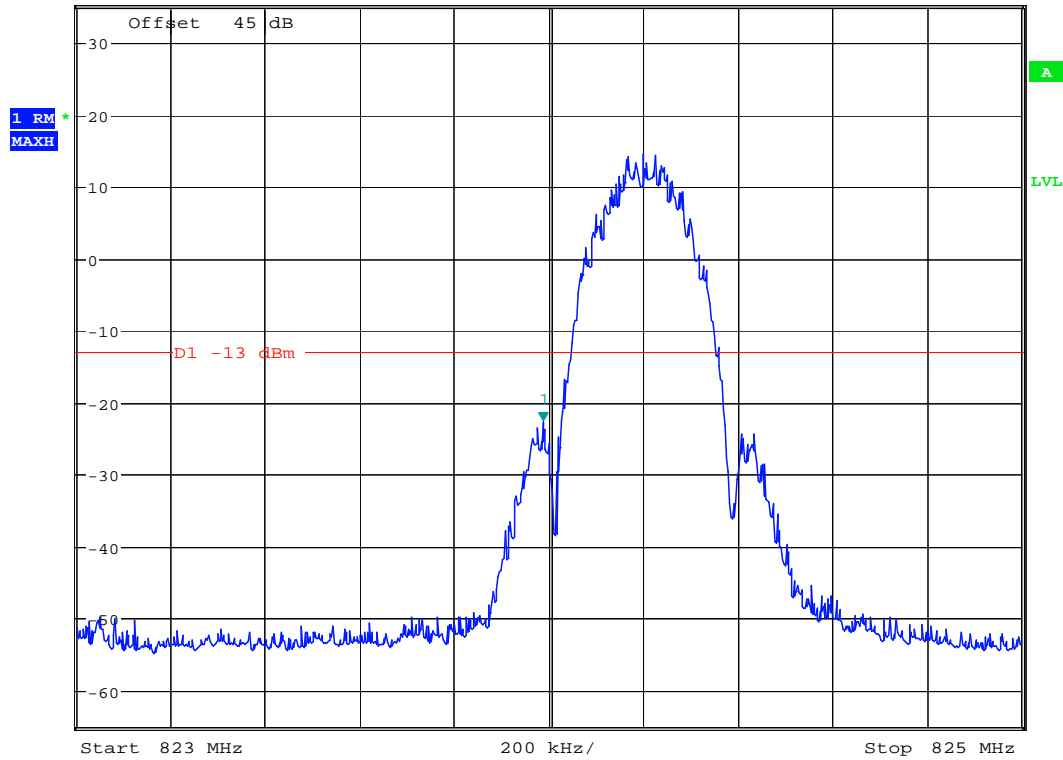

Date: 6.OCT.2007 10:53:29

Right Edge Channel 251

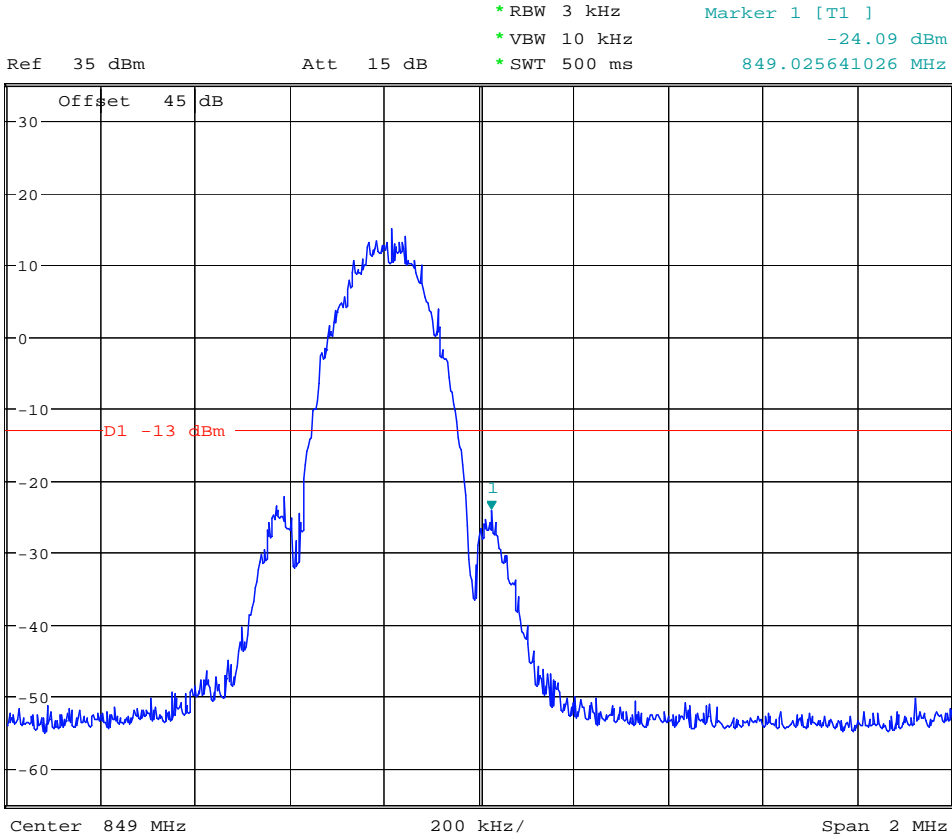

Date: 6.OCT.2007 10:51:50

Appendix D

Spurious Emission at Antenna Terminal

According to FCC Part 2.1051 & 22.917



*RBW 10 kHz Marker 1 [T1]
*VBW 30 kHz -28.04 dBm
*SWT 300 ms 197.836538462 kHz

Ref 35 dBm

Att 15 dB

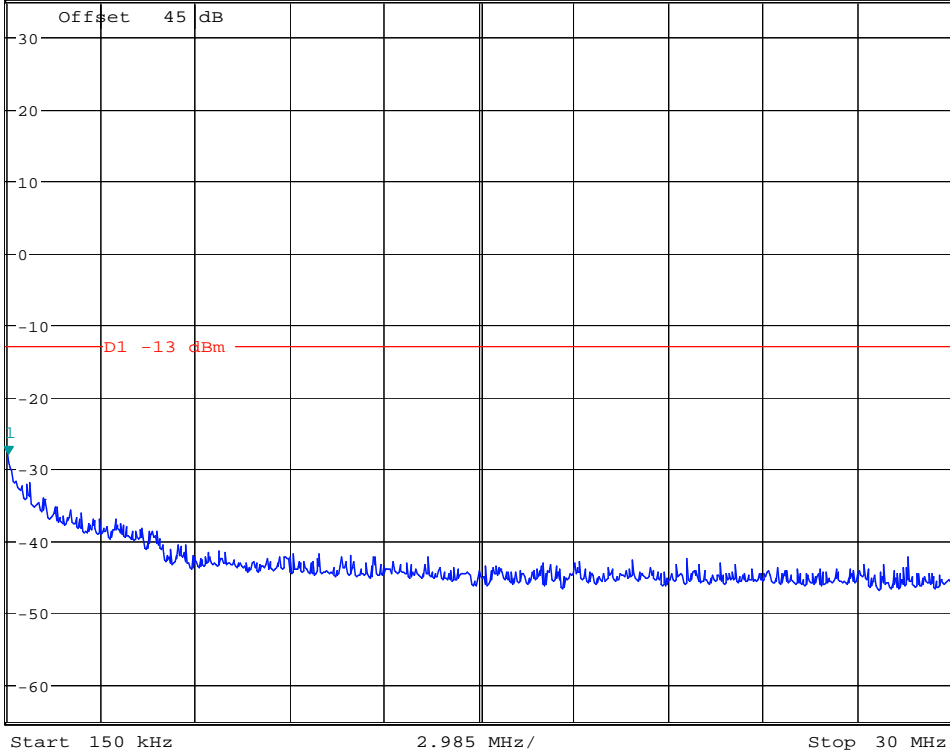

Date: 6.OCT.2007 11:02:30



* RBW 100 kHz Marker 1 [T1]
* VBW 300 kHz 27.36 dBm
* SWT 100 ms 825.897435897 MHz

Ref 35 dBm

Att 15 dB

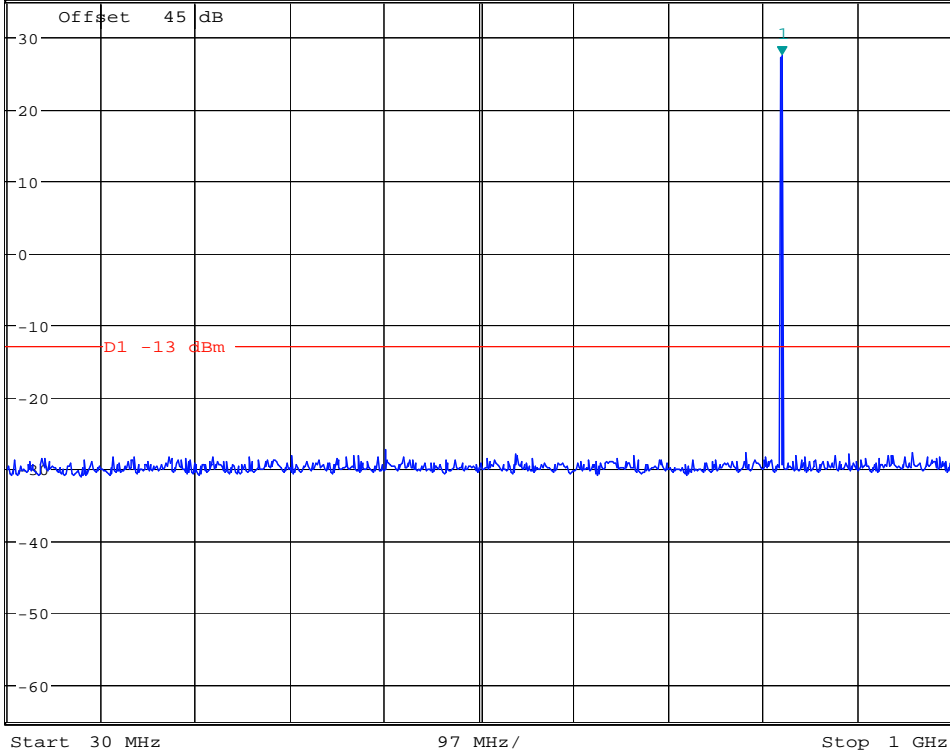

Date: 6.OCT.2007 11:16:42



* RBW 1 MHz Marker 1 [T1]
* VBW 3 MHz -17.55 dBm
* SWT 70 ms 3.598557692 GHz

Ref 35 dBm

Att 15 dB

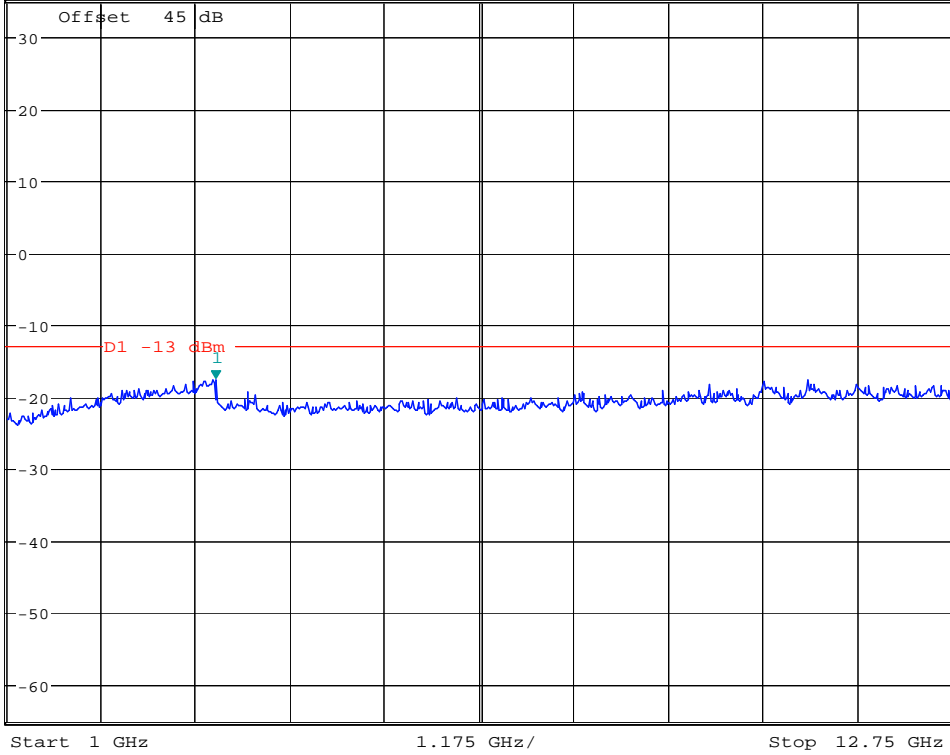

Date: 6.OCT.2007 11:13:22



* RBW 10 kHz
* VBW 30 kHz
* SWT 300 ms

Marker 1 [T1]
-27.15 dBm
150.00000000 kHz

Ref 35 dBm

Att 15 dB

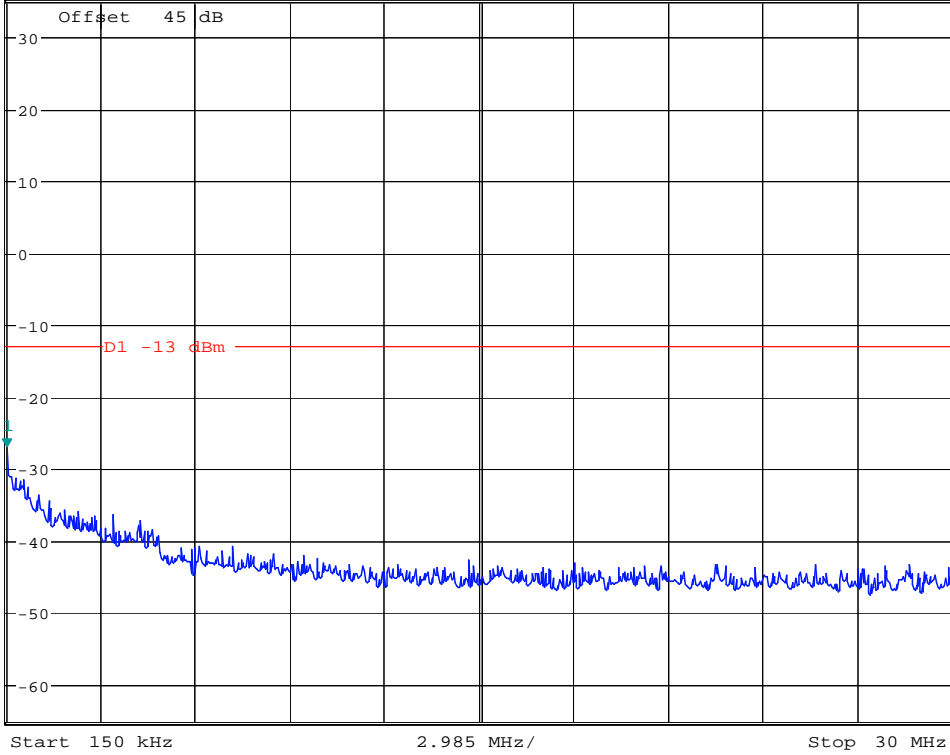

Date: 6.OCT.2007 11:15:01



* RBW 100 kHz Marker 1 [T1]
* VBW 300 kHz 27.15 dBm
* SWT 100 ms 838.333333333 MHz

Ref 35 dBm

Att 15 dB

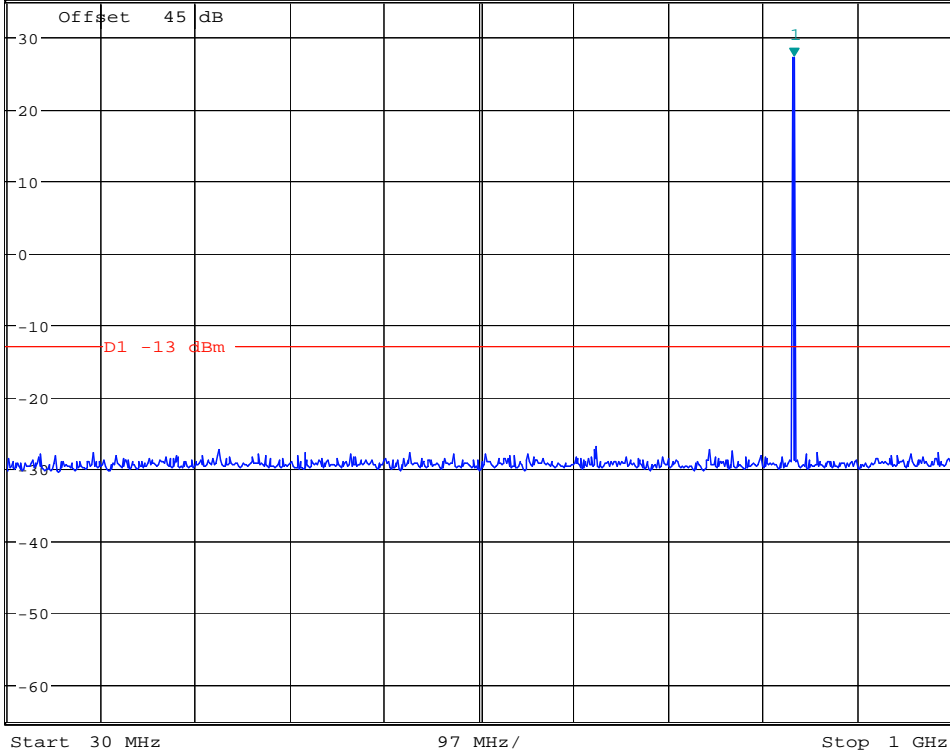

Date: 6.OCT.2007 11:16:12



* RBW 1 MHz Marker 1 [T1]
* VBW 3 MHz -17.55 dBm
* SWT 70 ms 3.542067308 GHz

Ref 35 dBm

Att 15 dB

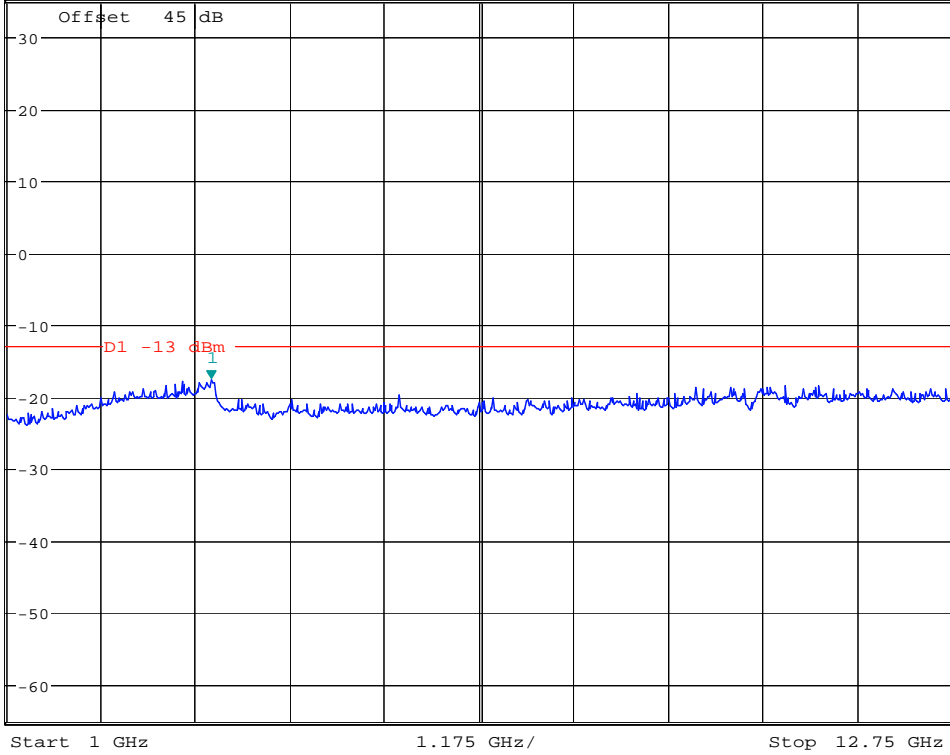

Date: 6.OCT.2007 11:19:35



* RBW 10 kHz
* VBW 30 kHz
* SWT 300 ms

Marker 1 [T1]
-29.52 dBm
197.836538462 kHz

Ref 35 dBm

Att 15 dB

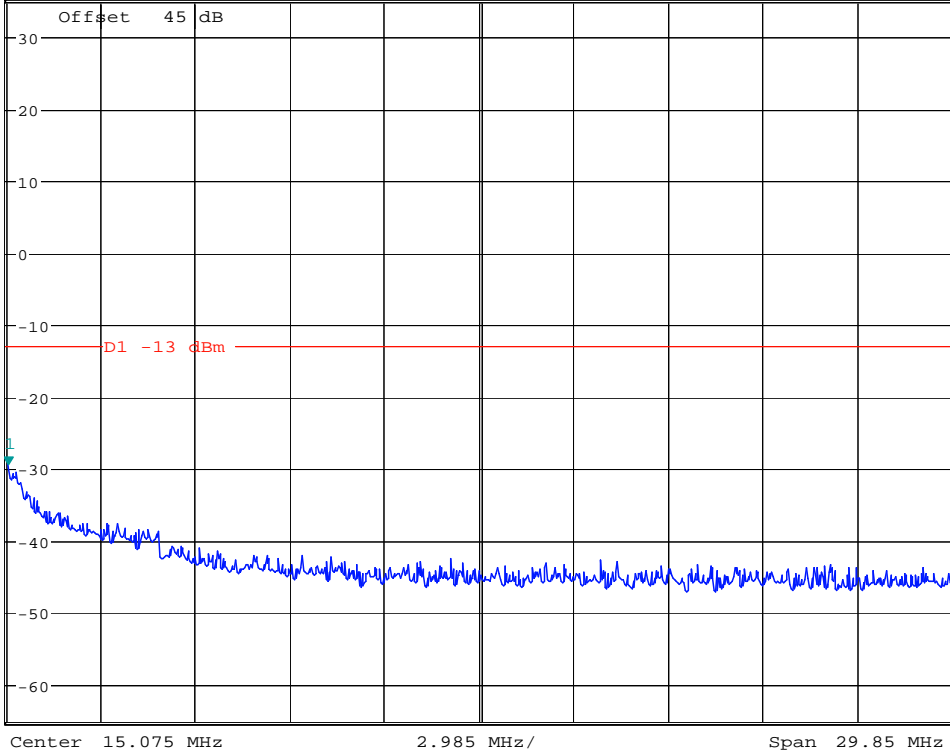

Date: 6.OCT.2007 11:20:53



Ref 35 dBm Att 15 dB *RBW 100 kHz Marker 1 [T1]
*VBW 300 kHz 27.16 dBm
*SWT 100 ms 849.214743590 MHz

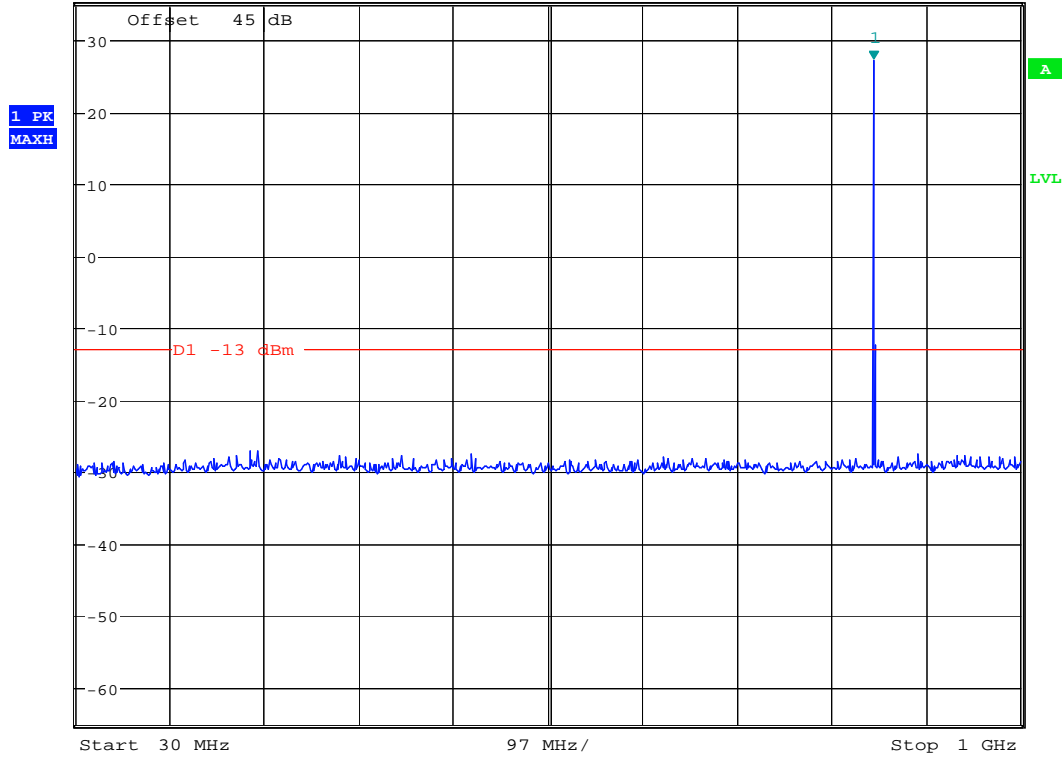

Date: 6.OCT.2007 11:17:31



* RBW 1 MHz Marker 1 [T1]
* VBW 3 MHz -17.01 dBm
* SWT 70 ms 3.372596154 GHz

Ref 35 dBm

Att 15 dB

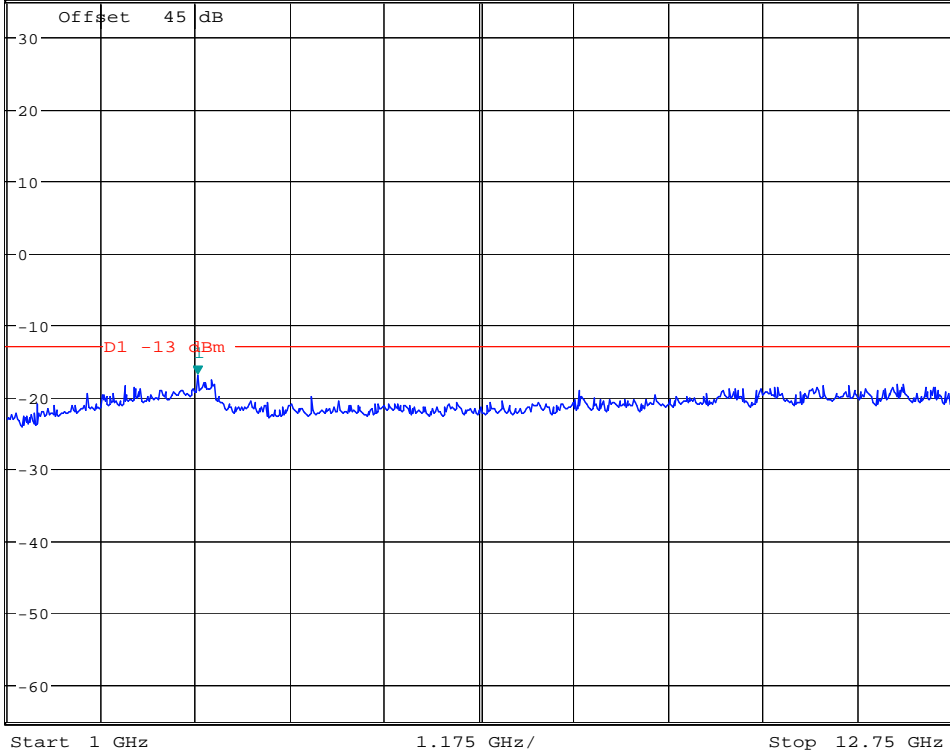

Date: 6.OCT.2007 11:19:07



*RBW 10 kHz Marker 1 [T1]
*VBW 30 kHz -28.04 dBm
*SWT 300 ms 197.836538462 kHz

Ref 35 dBm

Att 15 dB

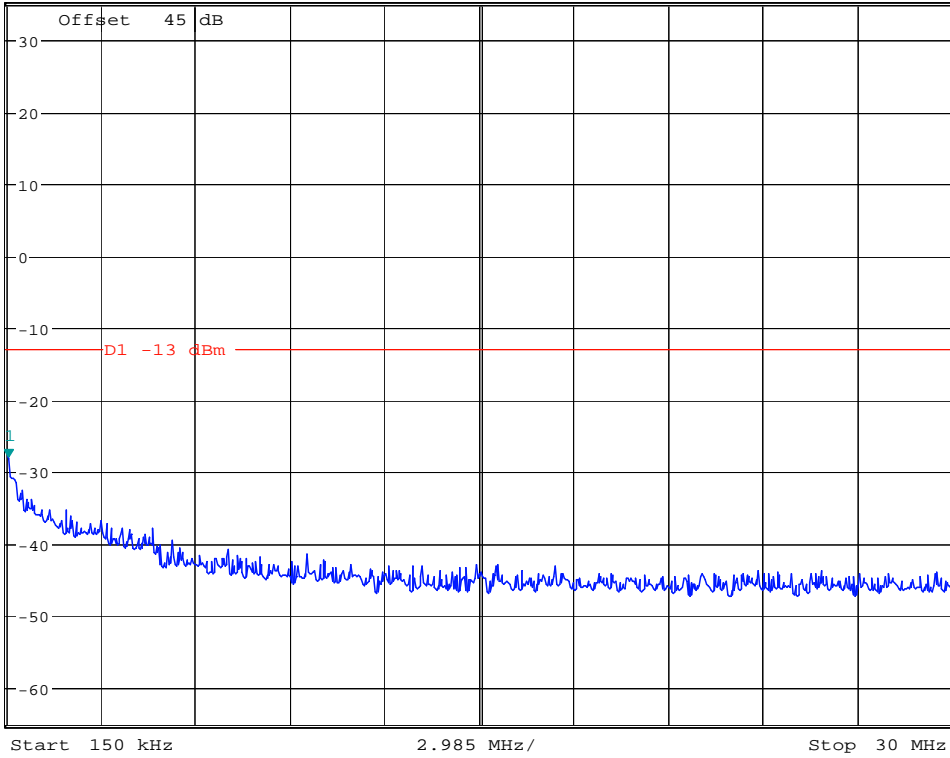

Date: 6.OCT.2007 11:26:44



Ref 35 dBm Att 15 dB *RBW 100 kHz Marker 1 [T1]
*VBW 300 kHz 22.74 dBm
*SWT 100 ms 825.897435897 MHz

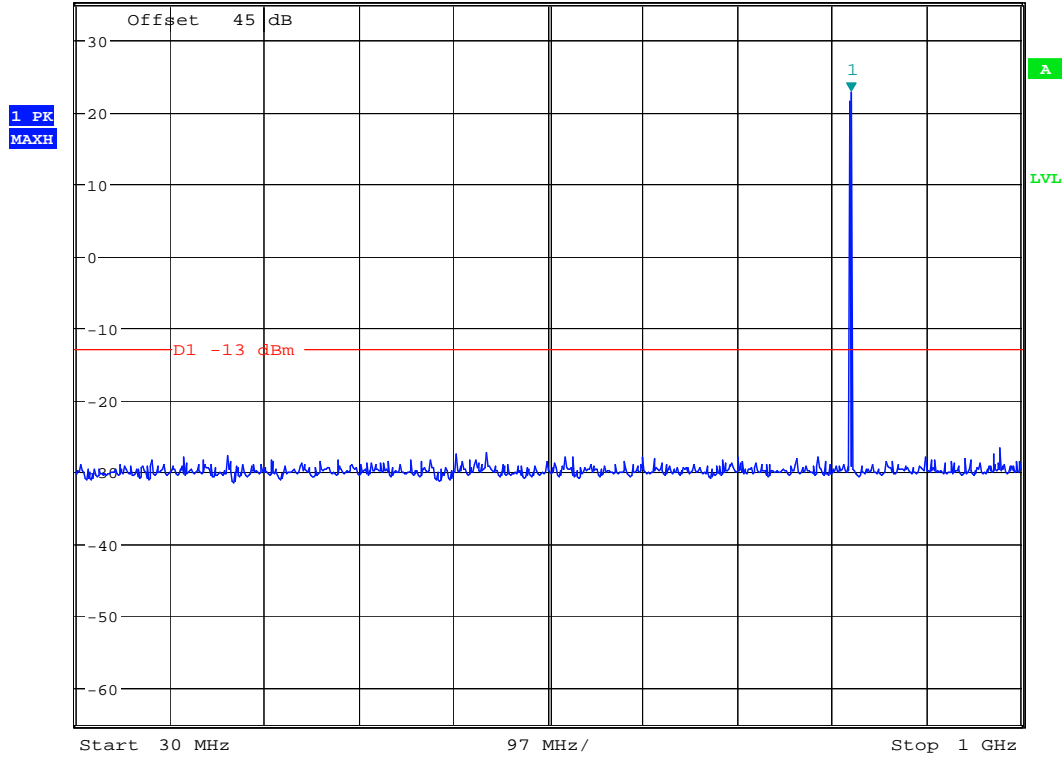

Date: 6.OCT.2007 11:28:18

Channel 192

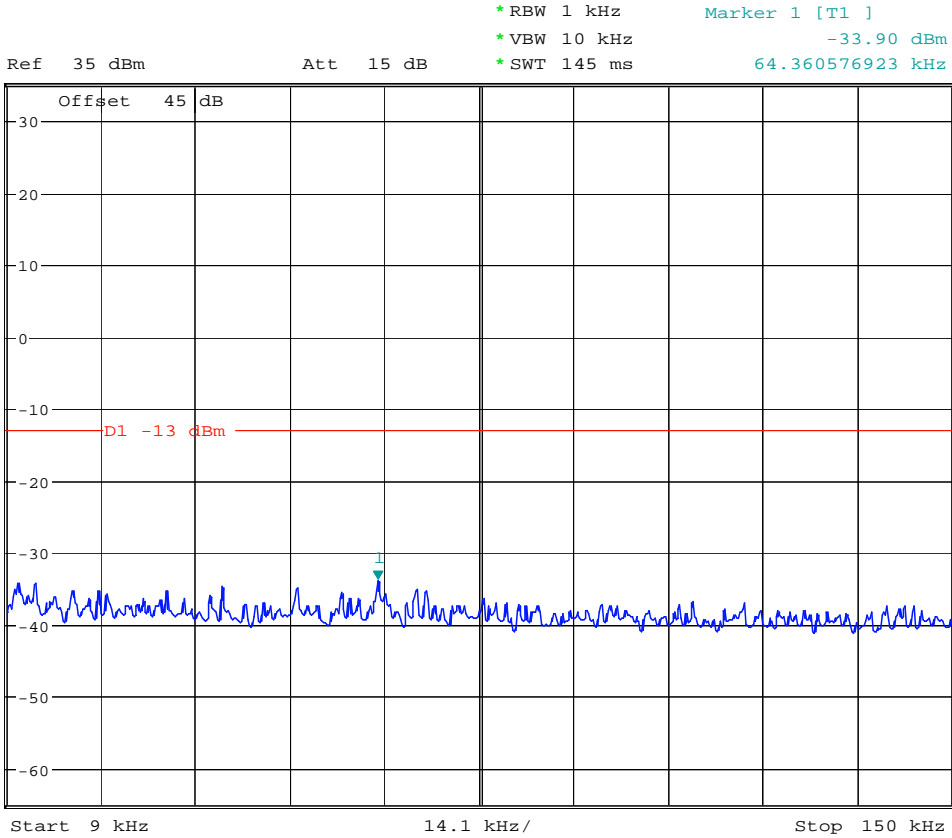

Date: 6.OCT.2007 11:24:53



*RBW 10 kHz Marker 1 [T1]
*VBW 30 kHz -30.27 dBm
*SWT 300 ms 245.673076923 kHz

Ref 35 dBm

Att 15 dB

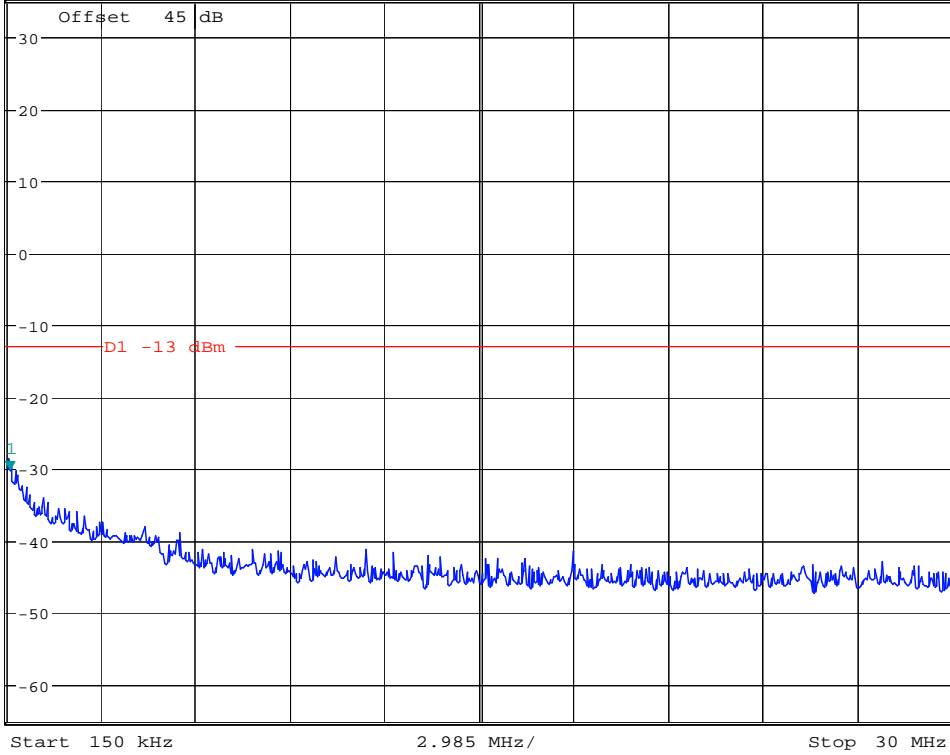

Date: 6.OCT.2007 11:27:05



*RBW 100 kHz Marker 1 [T1]
*VBW 300 kHz 22.03 dBm
*SWT 100 ms 838.333333333 MHz

Ref 35 dBm

Att 15 dB

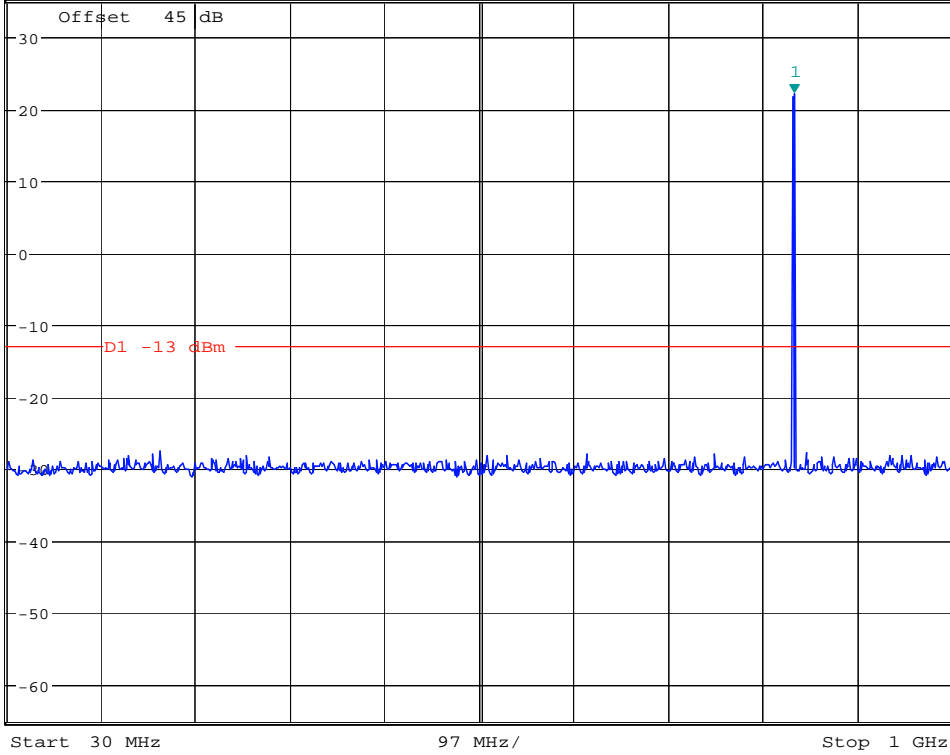

Date: 6.OCT.2007 11:27:51

Channel 251

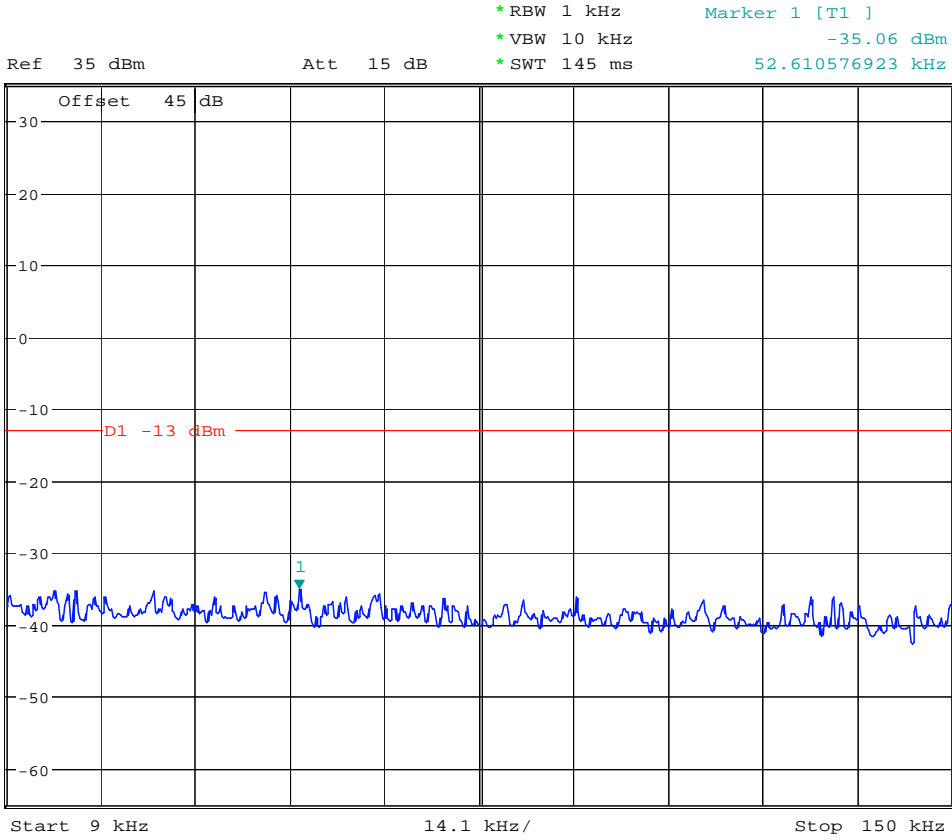

Date: 6.OCT.2007 11:25:13



*RBW 10 kHz Marker 1 [T1]
*VBW 30 kHz -28.33 dBm
*SWT 300 ms 150.00000000 kHz

Ref 35 dBm

Att 15 dB

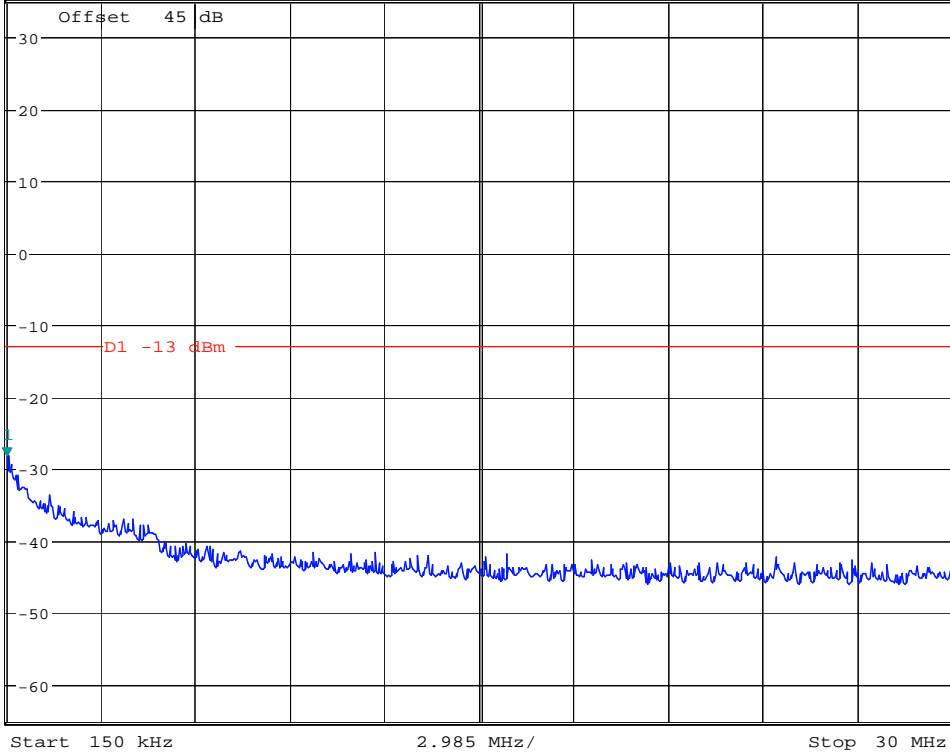

Date: 6.OCT.2007 11:26:18



*RBW 100 kHz Marker 1 [T1]
*VBW 300 kHz 21.49 dBm
*SWT 100 ms 849.214743590 MHz

Ref 35 dBm

Att 15 dB

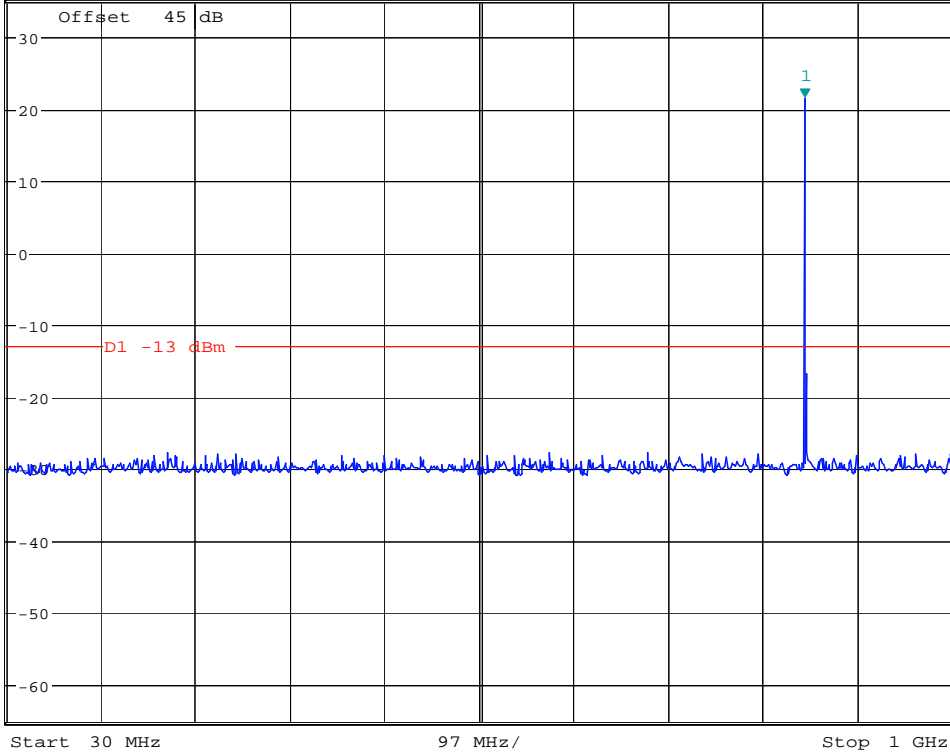

Date: 6.OCT.2007 11:28:39



*RBW 1 MHz Marker 1 [T1]
*VBW 3 MHz -17.64 dBm
*SWT 70 ms 3.560897436 GHz

Ref 35 dBm

Att 15 dB

1 PK
MAXH

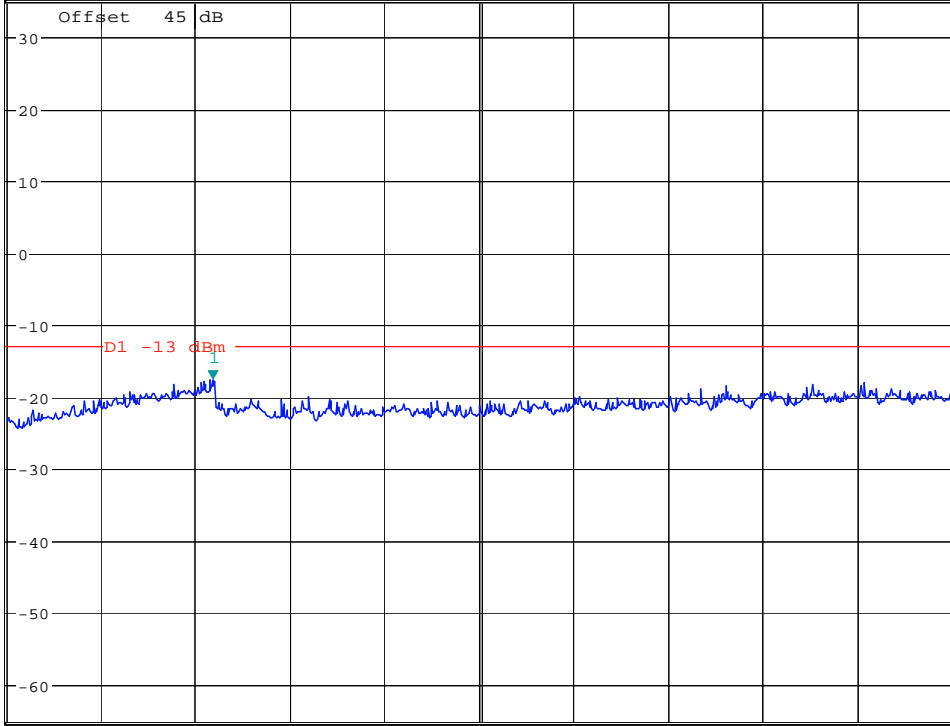

Start 1 GHz

1.175 GHz/

Stop 12.75 GHz

Date: 6.OCT.2007 11:29:10