

**12065**  
Pigeonite Basalt  
2109 grams

DRAFT □



*Figure 1: Photo of 12065 showing numerous zap pits on rounded surface. Scale is in cm. NASA # S69-60591.*

### **Introduction**

Sample 12065 is a large rounded pigeonite basalt dated at  $3.16 \pm 0.09$  b.y. The outer surface is covered with micrometeorite pits on all sides (figure 1).

### **Petrography**

12065 is a variolitic basalt composed of pyroxene and olivine phenocrysts (figure 2) imbedded in a very fine matrix of feathery ilmenite, plagioclase and clinopyroxene (figure 3)(Reid 1971). Kushiro et al. (1971) find that the fibrous pyroxene in 12065 is similar to “quench pyroxenes” often found in quenching experiments. 12065 has a few percent void space.

Kushiro et al. (1971) used the bulk composition of 12065 to perform experiments leading to the conclusion

that near-surface olivine ( $\text{Fo}_{74}$ ) and some pyroxene settling could explain the variation in composition of some Apollo 12 basalts.

### **Mineralogy**

***Olivine:*** Olivine composition in 12065 ranges from  $\text{Fo}_{72-32}$  (Kushiro et al. 1971).

***Pyroxene:*** Hollister et al. (1971) and Kushiro et al. (1971) describe complex sector zoning of pyroxene phenocrysts in 12065 (figure 4). Pigeonite cores are overgrown by subcalcic augite (Gay et al. 1971). Kushiro et al. report extreme Fe-enrichment in matrix pyroxene. Gay et al. report pyroxferroite with low Ca.

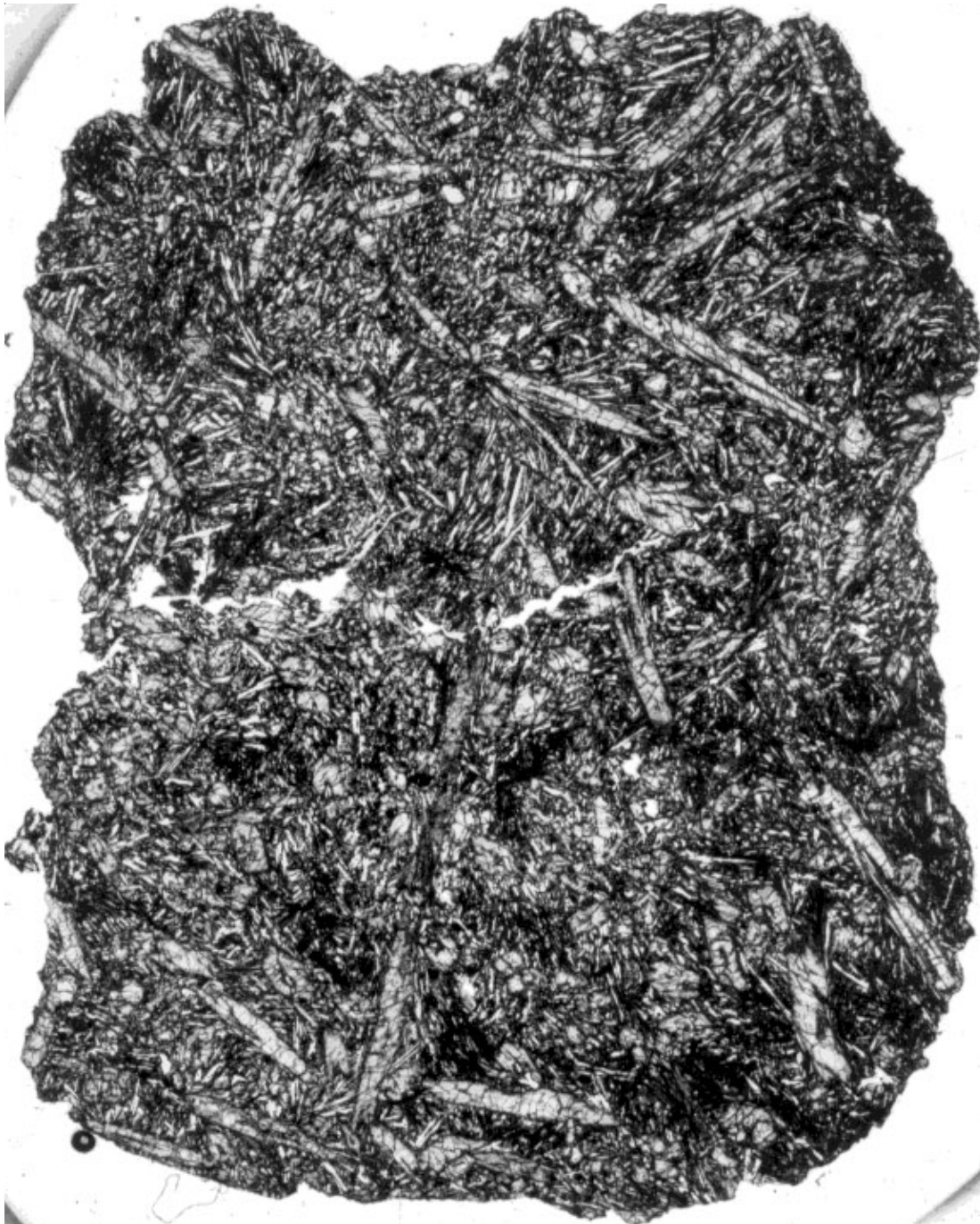

Figure 2: Photomicrograph of thin section 12065 showing elongate pyroxene in variolitic groundmass. Scale is about 2 cm. NASA # S69-23378.

**Plagioclase:** Plagioclase is  $An_{91} - An_{89}$  (Kushiro et al. 1971).

**Spinel:** The Ti content of the Cr-spinel increases with iron content from center to edge (Reid 1971). Kushiro et al. (1971) reported a large compositional gap between ulvöspinel and chromite.

### **Chemistry**

The chemical composition of 12065 has been reported by LSPET (1970), Maxwell et al. 1971, Kushiro et al. (1971), Goles et al. (1971), Smales et al. (1971), Bouchet et al. (1971) and Wänke et al. (1971) (table 1, figures 5 and 6). Moore et al. (1971) determined 31

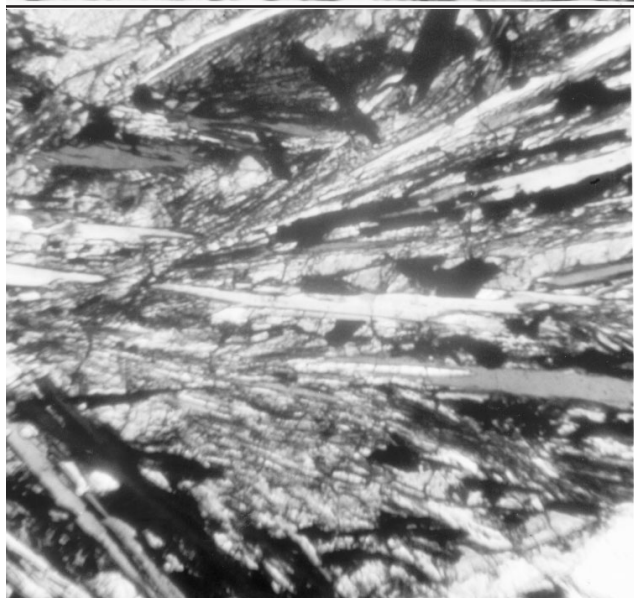
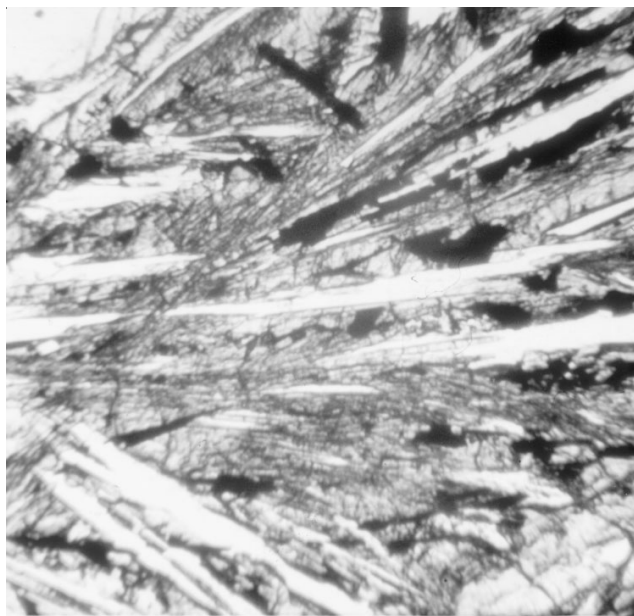

Figure 3: Photomicrographs of thin section 12065,7 (plane-polarized light; crossed-nicols) showing finely intergrown sheaths of plagioclase, pyroxene and ilmenite. Field of view 0.8 mm. NASA #S69-63438-439.

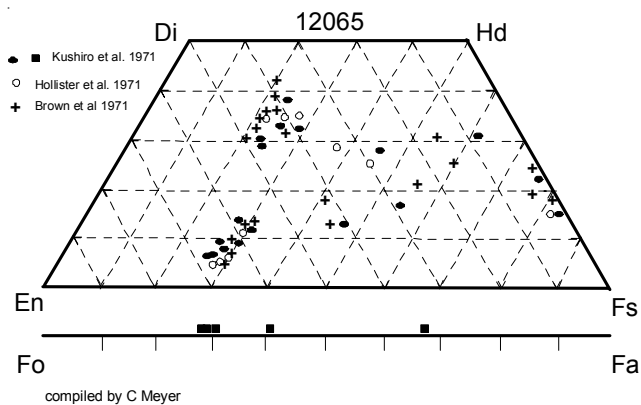

Figure 4: Pyroxene and olivine composition of 12065 (adapted from Kushiro et al. 1971, Brown et al. 1971 and Hollister et al. 1971).

ppm carbon in 12065. Lovering and Hughes (1971) determined Re and Os.

### **Radiogenic age dating**

Turner (1971) determined  $3.24 \pm 0.05$  b.y. by Ar/Ar (figure 8). Papanastassiou and Wasserburg (1971a) determined  $3.16 \pm 0.09$  b.y. by Rb/Sr mineral isochron (figure 7). Alexander et al. (1972) determined  $3.23 \pm 0.03$  b.y.

### **Cosmogenic isotopes and exposure ages**

Rancitelli et al. (1971) determined the activity of  $^{22}\text{Na}$  (32 dpm/kg),  $^{26}\text{Al}$  (82 dpm/kg),  $^{46}\text{Sc}$  (5.4dpm/kg),  $^{48}\text{V}$  (7 dpm/kg),  $^{54}\text{Mn}$  (31 dpm/kg) and  $^{56}\text{Co}$  (22 dpm/kg). Hintenberger et al. (1971) determined exposure ages for 12065 using  $^3\text{He}$  (180 m.y.),  $^{21}\text{Ne}$  (200 m.y.) and  $^{38}\text{Ar}$  (200 m.y.).

### **Other Studies**

Fleischer et al. (1971) determined the nuclear track densities in pyroxene and estimated the surface residence time. Bogard et al. (1971) reported the content and isotopic composition of rare gases in

### **Mineralogical Mode for 12065**

	Neal et al. 1994	Papike et al. 1976	Brown et al. 1971
Olivine	0.3	0.8	2.8
Pyroxene	68.6	70	68
Plagioclase	24.9	18.8	17
Opaques		10	11
Ilmenite	1.6		
Chromite +Usp	1.6		
mesostasis	2.1	0.1	
“silica”	0.5	0.3	

12065. Gromme and Doell (1971) and Hargraves and Dorety (1971) reported magnetic properties. Seismic wave velocities were determined as a function of pressure by Kanamori et al. (1971).

### Processing

In 1970, a slab (,16) was cut through the middle of 12065 and two columns (,19 and ,20) were cut from the slab (figures 9 – 11). For some reason, 12065,15 is on public display in Huntsville, Alabama (figure 13).

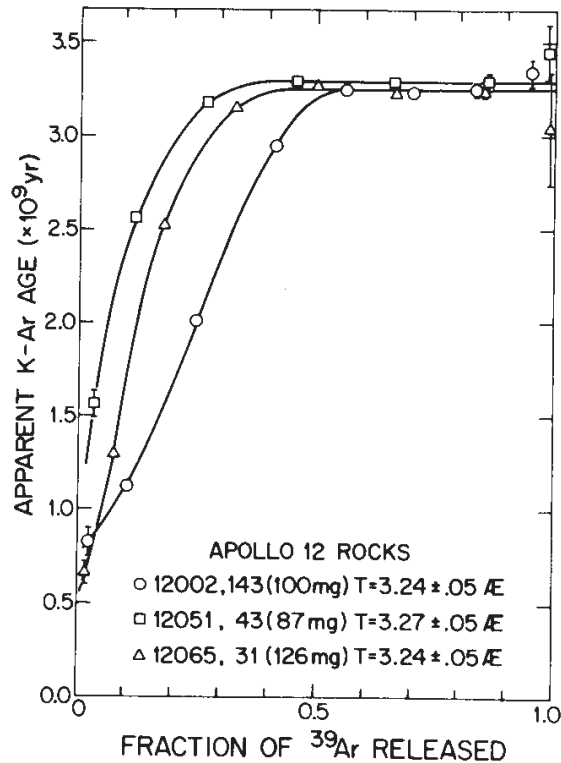

Figure 8: Ar-Ar release pattern for 12065 (from Turner 1971).

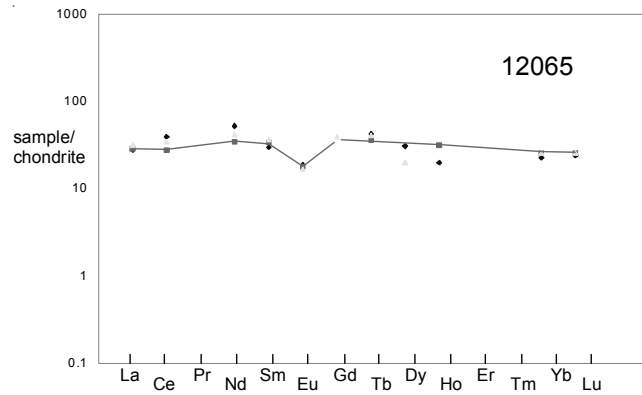

Figure 5: Normalized rare-earth-element composition diagram for 12065.

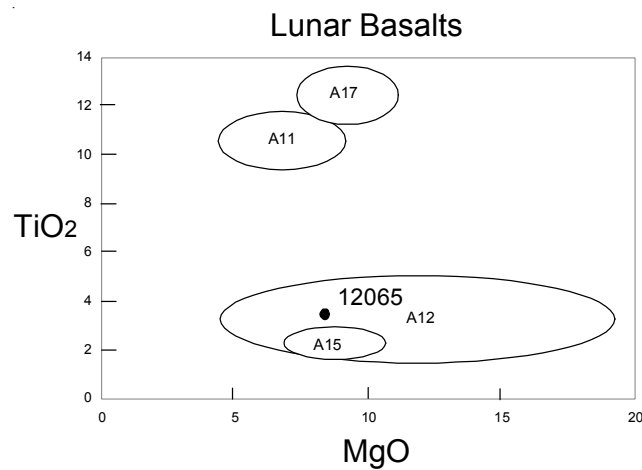

Figure 6: Composition of 12065 compared with that of other lunar basalts.

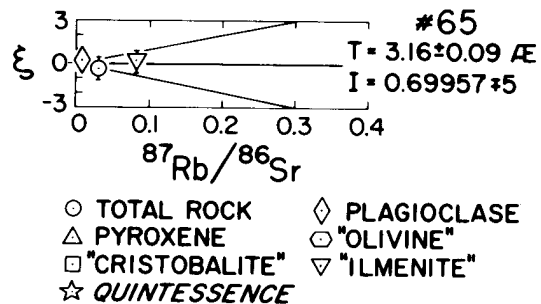

Figure 7: Rb-Sr isochron for 12065 (from Papanastassiou and Wasserburg 1971a).

### Summary of Age Data for 12065

	Ar/Ar	Rb/Sr	Nd/Sm
Turner 1971	3.24 ± 0.05 b.y.		
Alexander et al. 1972	3.23 ± 0.03		
Papanastassiou and Wasserburg 1971a		3.16 ± 0.09	

**Table 1. Chemical composition of 12065.**

reference weight	Maxwell71	Kushiro71 25 g 3.1 g	LSPET70	Goles71	O'Kelly71 2109 g	Wanke71	Anders71	Rancitelli71 1209 g
SiO <sub>2</sub> %	46.87	46.61 46.14	(c) 39	44.9 (a)		46.85 (a)		
TiO <sub>2</sub>	3.34	3.15 3.34	(c) 3.8	3.1 (a)		3.5 (a)		
Al <sub>2</sub> O <sub>3</sub>	10.05	10.58 10.73	(c) 12	9.2 (a)		10.33 (a)		
FeO	19.76	19.36 19.86	(c) 22	19.7 (a)		19.8 (a)		
MnO	0.256	0.26 0.26	(c) 0.41	0.26 (a)		0.29 (a)		
MgO	7.82	8.04 8.05	(c) 9			8.49 (a)		
CaO	10.73	11.13 10.96	(c) 12.6	11		10.8 (a)		
Na <sub>2</sub> O	0.27	0.34 0.25	(c) 0.39	0.25		0.24 (a)		
K <sub>2</sub> O	0.073	0.08 0.07	(c) 0.072		0.061 (d)	0.08 (a)		0.065 (d)
P <sub>2</sub> O <sub>5</sub>	0.13	0.21						
S %								
sum								
Sc ppm	50.6 (b)		60	50 (a)		56.5 (a)		
V	150 (b)		135	180 (a)				
Cr		3284	3500	3090 (a)		3560 (a)		
Co	39 (b)		34			38.8 (a)	43 42	(e)
Ni	20 (b)		25					
Cu	15 (b)					7.8 (a)		
Zn							0.93 0.67	(e)
Ga								
Ge ppb								
As								
Se							0.2 0.18	(e)
Rb			0.72				1.15 1.05	(e)
Sr	89 (b)		135					
Y	43 (b)		48					
Zr	140 (b)		180					
Nb								
Mo								
Ru								
Rh								
Pd ppb								
Ag ppb							1.37	(e)
Cd ppb								1.2 (e)
In ppb							2.2	(e)
Sn ppb								
Sb ppb								
Te ppb								
Cs ppm							0.07 0.05	(e)
Ba			70	90 (a)				
La	7.5 (a)			6.9 (a)		6.68 (a)		
Ce	21 (a)			17 (a)		24 (a)		
Pr								
Nd	19 (a)			16 (a)		24 (a)		
Sm	5.5 (a)			5.02 (a)		4.5 (a)		
Eu	0.96 (a)			1.01 (a)		1.06 (a)		
Gd	7.8 (a)							
Tb	1.51 (a)			1.3 (a)		1.58 (a)		
Dy	4.9 (a)					7.64 (a)		
Ho				1.8 (a)		1.11 (a)		
Er								
Tm	0.69 (a)							
Yb	4.3 (a)			4.15 (a)		3.78 (a)		
Lu	0.64 (a)			0.64 (a)		0.59 (a)		
Hf	2.8 (a)			3.58 (a)		3.9 (a)		
Ta	0.68 (a)			0.39 (a)		0.51 (a)		
W ppb								
Re ppb								
Os ppb								
Ir ppb							0.08 0.05	(e)
Pt ppb								
Au ppb							0.01 0.01	(e)
Th ppm					1.06 (d)			0.991 (d)
U ppm					0.27 (d)			0.282 (d)

technique: (a) INAA, (b) OES, (c) conventional wet, (d) radation counting, (e) RNAA

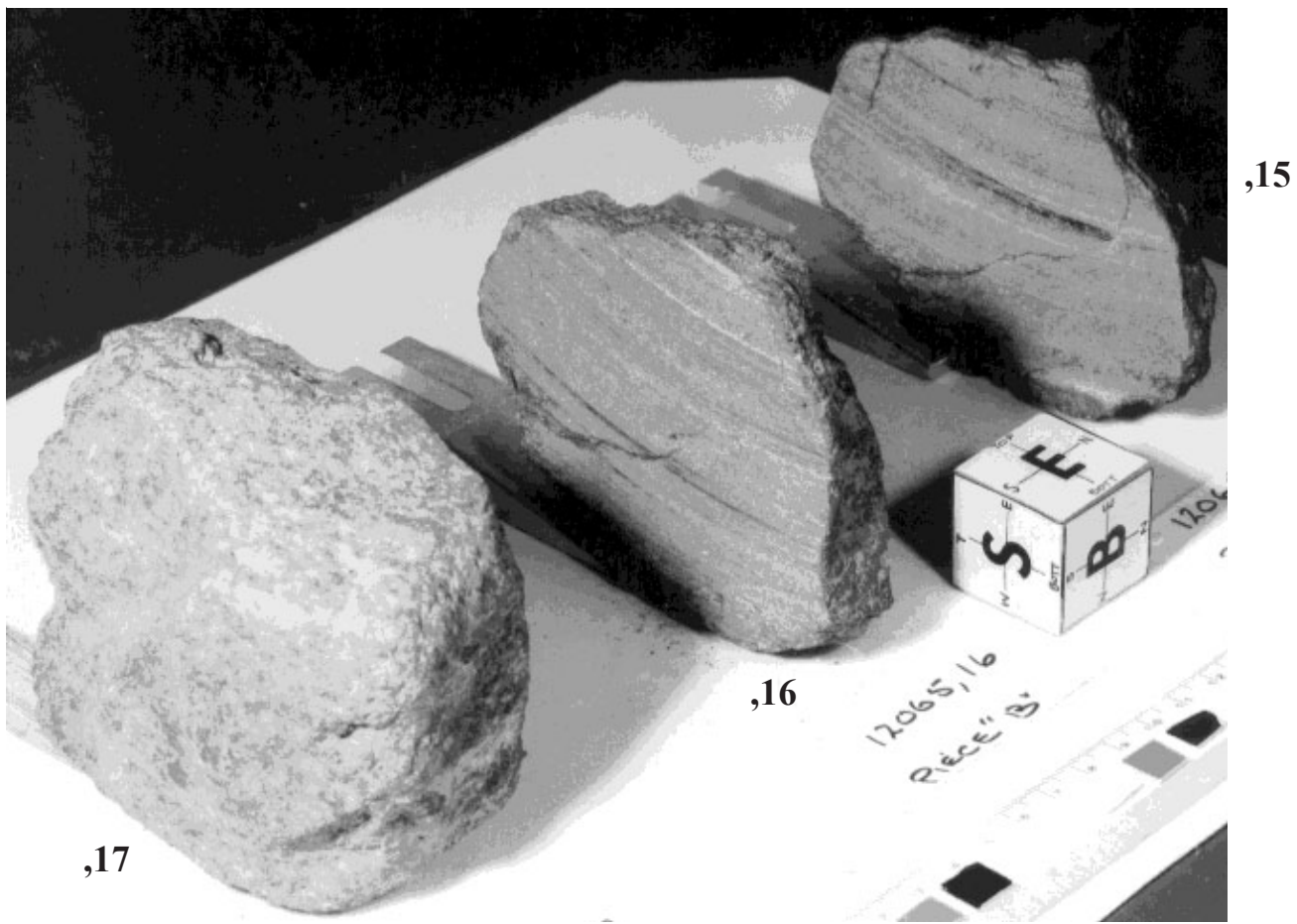

Figure 9: Group photo of 12065 after sawing slab. NASA # S70-37260.

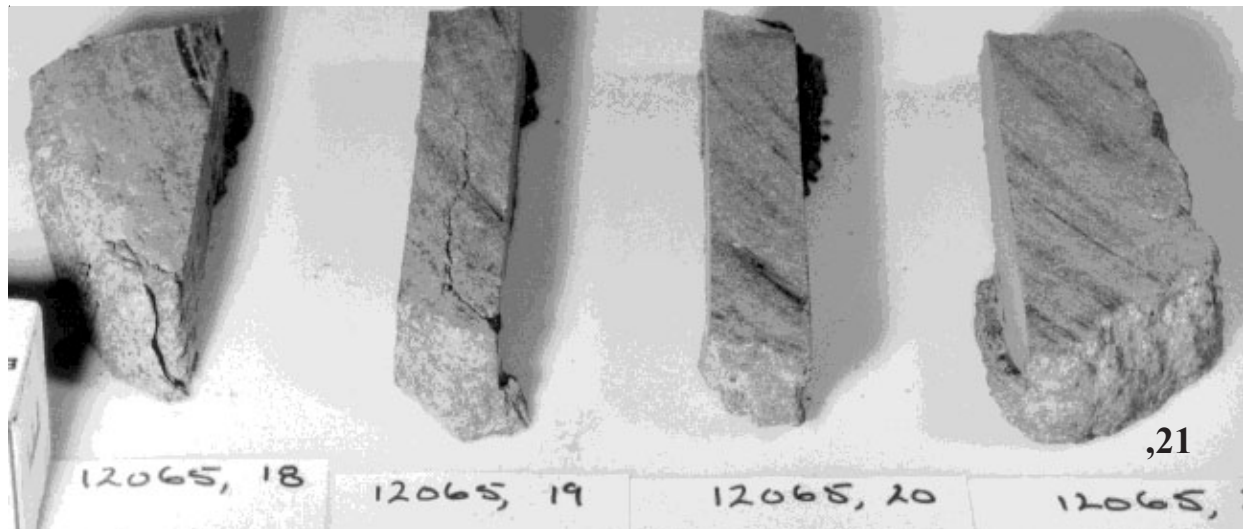
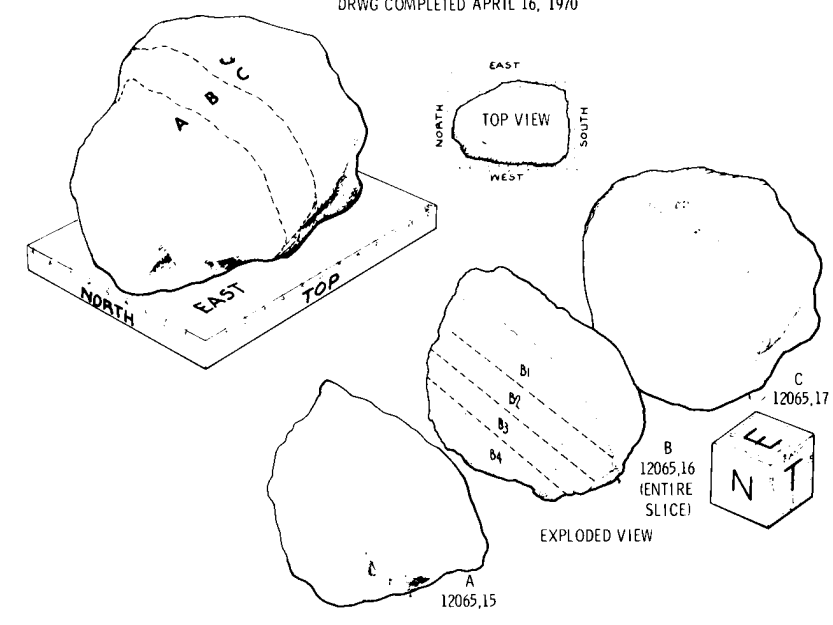

Figure 10: Group photo of columns cut from slab 12065,16. Thickness of slab is 1.6 cm. NASA # S70-37272.

DRWG COMPLETED APRIL 16, 1970



THE CUTTING OF SLICE 'B1' NO. 12065,21

DRWG COMPLETED APRIL 17, 1970

REVISION NO. 1  
5/21/70

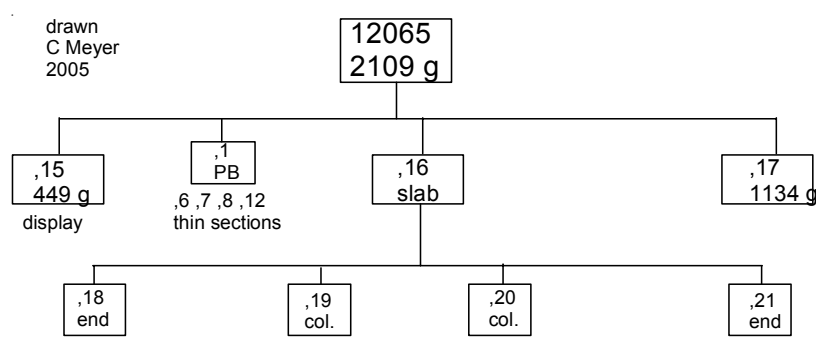
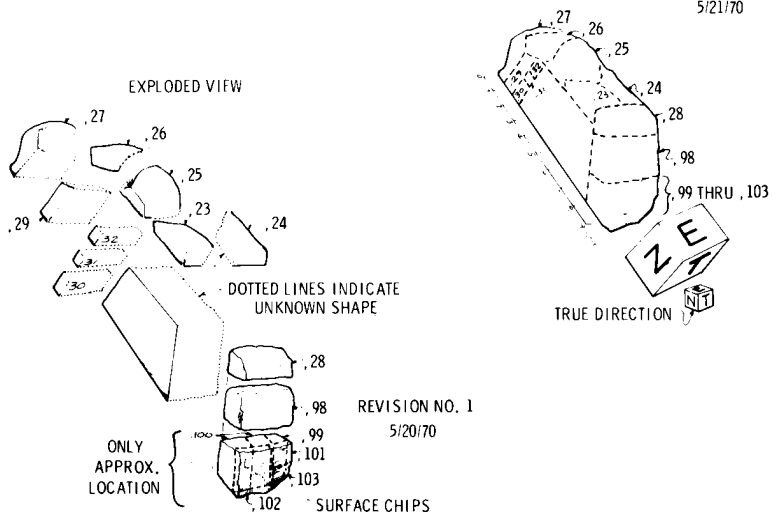

DRWG COMPLETED APRIL 20, 1970

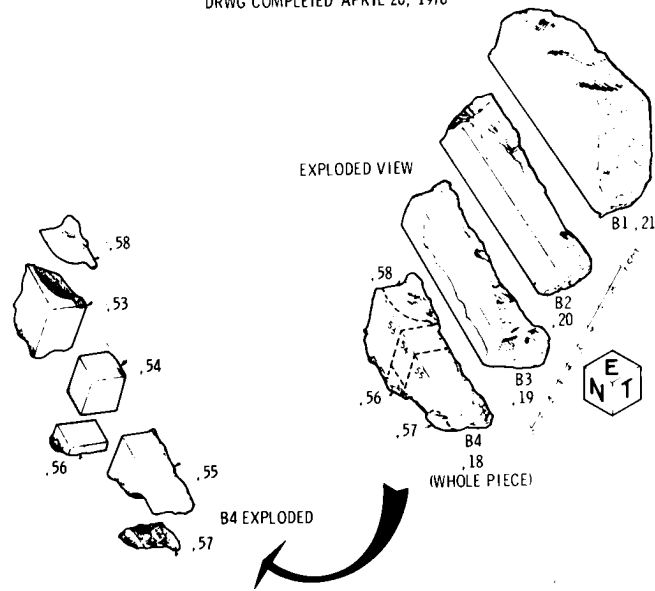

THE CUTTING OF SLICE 'B2' NO. 12065,20

DRWG COMPLETED APRIL 22, 1970

REVISION NO. 1  
5/21/70

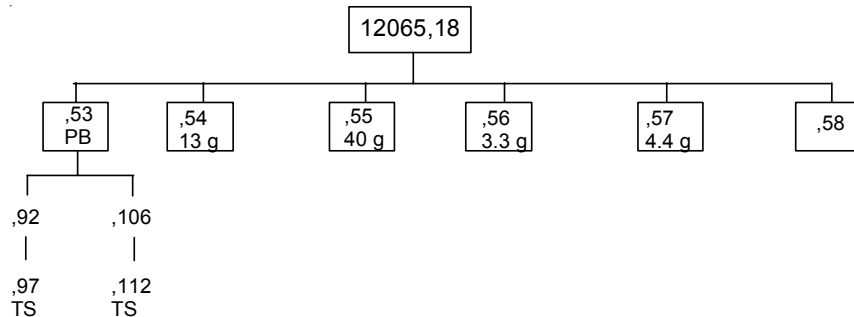
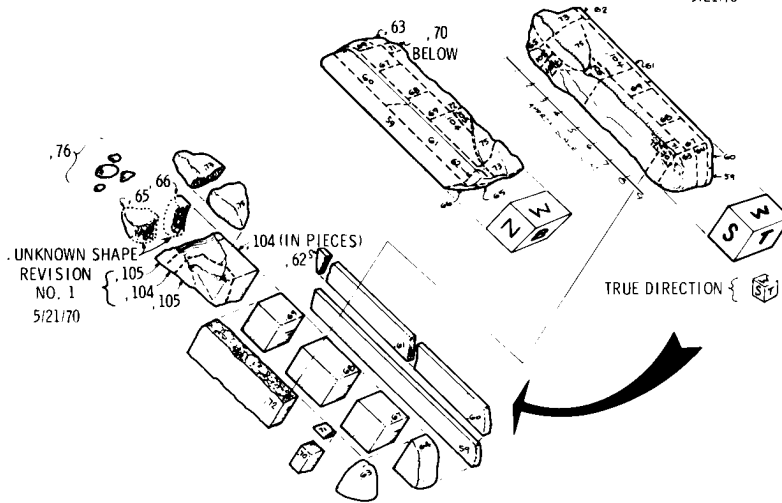



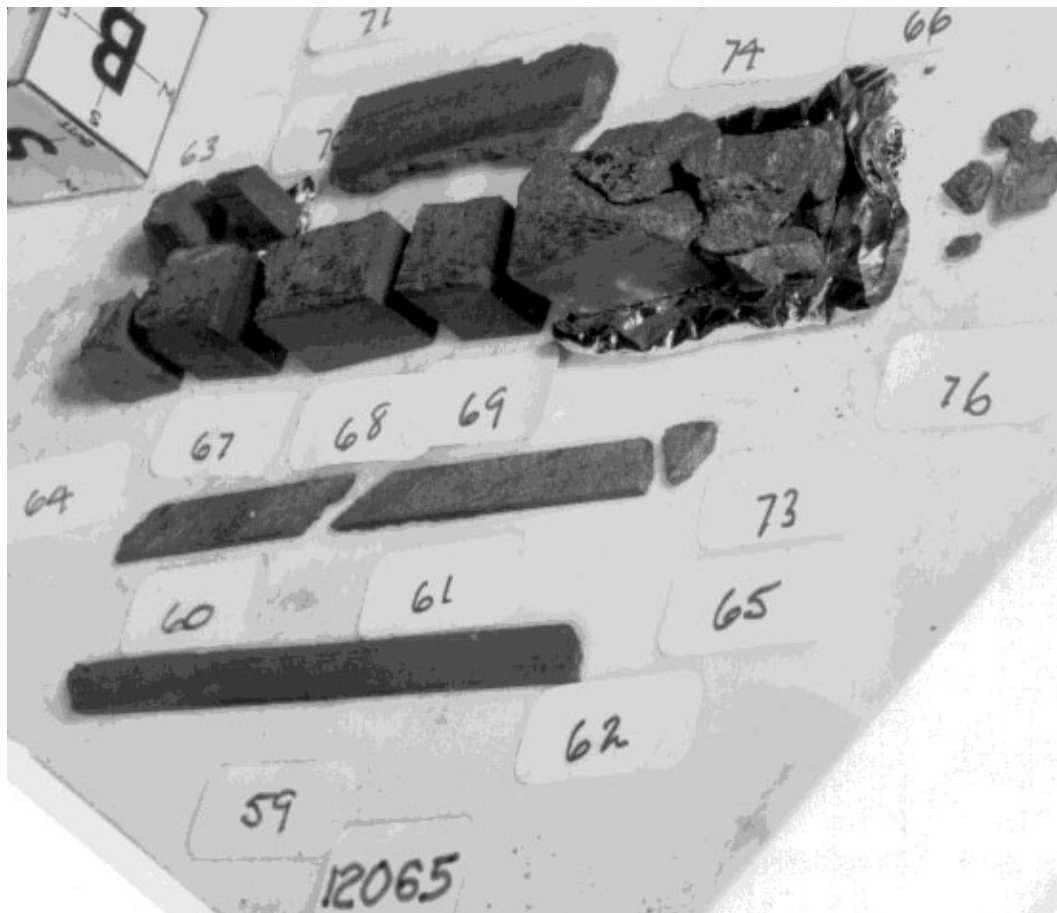

Figure 11: Group photo of column (,20) cut from slab 12065,16. NASA # S70-37268.

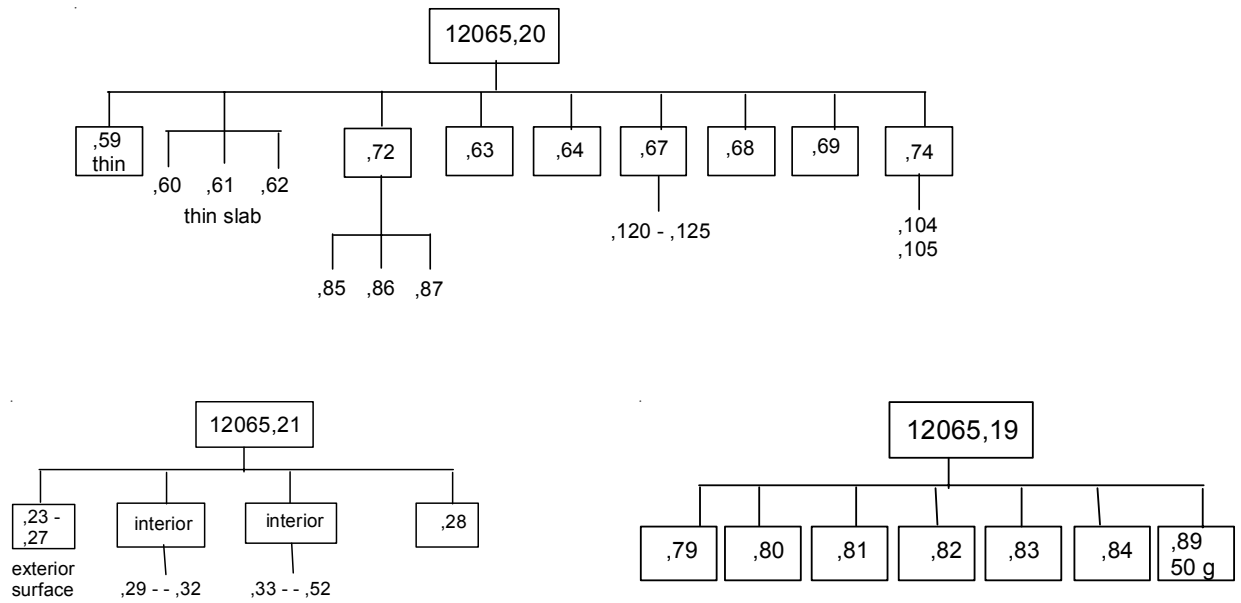



Figure 13: 12065,15 on display. NASA # S89-35328.

**List of Photo #s of 12065**

S69-23361	TS
S69-23363	
S69-23376	
S69-23378	
S69-63405	
S69-63630	
S69-63438 – 63439	TS color
S69-64880	
S69-61665 – 61666	
S69-60573 – 60596	B & W mug
S70-20737	TS
S70-37260	processing
S70-37268	processing
S70-37272	processing
S70-40815	TS best
S70-40824	TS
S70-49850 – 49857	TS color
S89-35328 – 35330	display