

CONFIDENTIALe.1
Copy 5
RM L52G16

SEP 24 1952

UNCLASSIFIED



RESEARCH MEMORANDUM

TESTS OF A CENTERING SPRING USED AS AN ARTIFICIAL FEEL
DEVICE ON THE ELEVATOR OF A FIGHTER AIRPLANE

By James J. Adams and James B. Whitten

Langley Aeronautical Laboratory
Langley Field, Va.

CLASSIFICATION CANCELLED

FOR REFERENCE

Author: NACA R7 2754 Date: 10/12/54

By: MTA 11/9/54 See _____

NOT TO BE TAKEN FROM THIS ROOM

CLASSIFIED DOCUMENT

This material contains information affecting the National Defense of the United States within the meaning of the espionage laws, Title 18, U.S.C., Secs. 793 and 794, the transmission or revelation of which in any manner to unauthorized person is prohibited by law.

NATIONAL ADVISORY COMMITTEE FOR AERONAUTICS

WASHINGTON
September 12, 1952

UNCLASSIFIED

CONFIDENTIAL

NACA LIBRARY

LANGLEY AERONAUTICAL LABORATORY
LANGLEY FIELD, VA.

NACA RM L52G16



UNCLASSIFIED

NATIONAL ADVISORY COMMITTEE FOR AERONAUTICS

RESEARCH MEMORANDUM

TESTS OF A CENTERING SPRING USED AS AN ARTIFICIAL FEEL

DEVICE ON THE ELEVATOR OF A FIGHTER AIRPLANE

By James J. Adams and James B. Whitten

SUMMARY

Tests have been made to investigate the use of a simple centering spring, which had no variation of force gradient with impact pressure, as an artificial feel device for the elevator control of a fighter airplane. The tests were conducted with a Chance Vought F4U-4B airplane which was equipped with power controls.

The investigation showed that the centering spring alone is not satisfactory when the spring is strong enough to give reasonable values of force per g because of the excessive stick force encountered in landing. When a preloaded spring was included in the feel system to remedy this high stick force in landing, and when a bobweight was added to increase the force per g, the device gave variations of force per g that were within the required limits over the speed range of the test airplane at the test center-of-gravity position. Even though the characteristics of the force per g were within the required limits, the pilot judged the system to be unsatisfactory because of insufficient centering tendency at high speed. It would be difficult to adapt this centering-spring type of feel device to the elevator of an airplane intended for transonic speeds because of the aggravated problems of obtaining satisfactory stick forces throughout the extended speed range.

INTRODUCTION

The increasing use of power controls on high-speed airplanes has made necessary the development of artificial feel devices to supply a satisfactory stick feel to the pilot. In order to gain experience with this problem, a Chance Vought F4U-4B airplane was obtained which had been equipped with irreversible power controls on all control surfaces, and various feel systems were installed in the airplane. In the present investigation, tests were made of the elevator feel supplied by a

~~CONFIDENTIAL~~

UNCLASSIFIED

centering-spring arrangement. The merits of such a system are discussed and the flight results are presented in this paper.

The airplane was originally equipped with an elevator feel system consisting of a bellows and cam arrangement, as shown in figure 1(a), which gave a stick force proportional to free-stream impact pressure and stick displacement. The cam was designed to give a linear stick-force variation with stick displacement, and the bellows regulated the slope of this variation in proportion to the impact pressure. The results of some previous Navy tests of this arrangement are presented in reference 1. During these tests it was found that it was difficult to obtain longitudinal trim or precise longitudinal control. The trouble was traced to friction in the valve which regulated the flow of hydraulic fluid in the booster system. In the present tests, this trouble was minimized by reducing the booster valve friction as far as possible, so that satisfactory evaluation of the feel device could be made.

Although a fair evaluation of the bellows and cam or "q" feel system was not made because of these control difficulties attributed to the booster system, a similar q feel system in another airplane has been shown to be satisfactory (ref. 2). With this fact established, it was decided to try to develop a simpler elevator feel system consisting essentially of centering springs restraining the stick. If such a feel system could be made to give satisfactory elevator feel, it would have the advantage of much simpler construction as compared to the q feel system.

DESCRIPTION OF AIRPLANE

The airplane used in the present investigation was an F4U-4B Navy Corsair fighter, shown in figure 2, which was equipped with power controls on all control systems. A drawing of the airplane is shown in figure 3, and the physical characteristics are listed in table I. A detailed description of the power control system can be found in reference 3.

Apparatus and Tests

To obtain the effect of a centering-spring system with the least amount of revision to the airplane, the bellows of the original system was replaced by rubber shock cords which gave a constant force of about 400 pounds. A drawing of this arrangement is shown in figure 1(b). The variation of stick force with stick deflection is shown in figure 4. The slope through zero is 2.7 pounds per degree. At large deflections

the slope increased, probably because of increased tension in the shock cords. Figure 5 presents the variation of elevator angle with stick angle.

With the stick-force calibration and the known variation of elevator angle with airspeed and acceleration, as shown in figure 6, the stick forces that can be expected with the centering-spring feel system can be derived. These calculated stick forces, shown on figure 7(a), are presented for comparison with the flight-test data. It can be seen that a high landing force of 60 pounds is predicted. This high stick force in landing is caused mainly by the large increment in up-elevator angle required by the ground effect. The force per g at a low speed of 150 miles per hour is within the satisfactory range, but the force per g at 300 miles per hour is below the minimum of 3 pounds per g required by the handling-qualities requirements (ref. 4).

To relieve the high stick force at landing, a preloaded spring could be placed in the system as shown on figure 1(c). The spring that was subsequently used had a 16 pounds per inch spring constant and was installed with a preload which corresponded to a 14-pound-pull force at the stick. The calibration of stick force against stick position for this system is shown in figure 4. With the preloaded spring, it should be possible to make a landing without exceeding an 18-pound-pull force.

One possible disadvantage of including a preloaded spring in the feel system is that, when the center of gravity is at a forward position, it would be possible to experience a decrease in slope of the variation of stick force with g at higher values of g as the stick is pulled back past the force break point. This is illustrated in figure 7(b) which presents the estimated stick-force variation against g for a center-of-gravity position of 24 percent mean aerodynamic chord.

To increase the force per g so that it will be above the required minimum at high speeds, a bobweight can be added as shown on figure 1(c). The bobweight that was used in the present tests added 2 pounds per g to the stick force. With the increase of 2 pounds per g , the force per g would be within the required limits up to 300 miles per hour. It appears that, by adding a preloaded spring and a bobweight to the centering spring, the feel system should satisfactorily meet the handling-qualities requirements within the speed range of the test airplane.

In each of the conditions mentioned above, flight tests were made in which the elevator-stick-force variation with g in steady turns and the force used in landing were recorded. The flight tests were restricted to one center-of-gravity position, 26.7 percent mean aerodynamic chord. No further rearward movement was possible because the airplane was close to neutral stability in maneuvers, and no further forward movement was practical because all the ballast that could conveniently be installed

ahead of the center of gravity, had already been employed to offset the weight of the test equipment and booster installation. The very small control deflections needed to maneuver the airplane aggravated the problem of obtaining satisfactory values of force per g at high speeds and at the same time obtain a reasonable stick force at landing.

Standard NACA recording instruments were used to measure airspeed, acceleration, stick force, stick position, and elevator position. The stick position was measured close to the stick, and the elevator position, at the elevator hinge line.

RESULTS AND DISCUSSION

The results of the flight tests are shown in figure 8. Figure 8(a) presents the force per g , the stick position, and the elevator position obtained with the simple centering spring; figure 8(b) presents the data for the centering spring plus the preload spring; figure 8(c) presents the data for the centering spring plus the preload spring and the bobweight.

With the centering spring only in the feel system, the stick force used in landing was very high, as was expected. The actual force used exceeded the range of the recording instrument and was not recorded. The pilot felt that he had to pull an excessive force. The force per g at low speed was satisfactory, 5.5 pounds per g being measured. The force per g at 300 miles per hour was not as low as was expected, a slope of 3 pounds per g being measured.

With the preloaded spring included in the feel system, the stick force at landing was satisfactory. A maximum stick force of 18 pounds was recorded during the landing. An attempt was made to maneuver the airplane so that the stick position at which the force break occurs would be passed, but it was found to be difficult to do this at the test center-of-gravity position.

With the preloaded spring and the bobweight included in the feel system, the landing force was again satisfactory. The force per g at 200 miles per hour was 4.8 pounds per g , and at 300 miles per hour was approximately the same. By comparison of figures 8(a) and 8(c) with figure 6 it can be seen that the force per g does not decrease with increase in airspeed as rapidly as was expected. This result can be partially explained by the change in variation of stick angle against elevator angle with increasing airspeed shown on figure 9. The figure shows that the change in stick angle for a given change in elevator angle increases with increasing airspeed. This indicates that the increasing aerodynamic hinge moments at higher airspeeds are causing some stretch

or deflection in the control linkage. Since the feel device is located near the stick, this flexibility results in an increase in stick force per degree of elevator deflection.

Even though the effects of the bobweight and the flexibility in the control linkage kept the force per g above the 3 pounds per g minimum requirement and kept the force per g constant from 200 to 300 miles per hour, the pilot was not satisfied with the system. He felt that the centering tendency was insufficient at high speed. This criticism has been made of other airplanes which had a small variation of stick force with stick deflection (ref. 5). The pilot would have preferred an increase in centering with increasing speed, such as would have been created by a q feel system which would have resulted in an increase in force per g with increasing speed.

A factor which would affect the centering action of the feel device is the friction in the control system. Figure 4 shows the friction in the test control linkage to be about 3 pounds, which is the maximum allowable friction force allowed in the elevator control of a fighter airplane. This friction force could keep the control 1° from trim position if the controls were displaced and then released. With the present type of control system, this out-of-trim displacement remains constant throughout the speed range, and the accelerations which might result become greater with increasing airspeed. With a q feel system or a manual control system the control displacement would decrease with increasing speed, and the resulting acceleration would remain constant. Therefore, it would appear necessary to limit the control linkage friction to smaller values than are presently required to obtain adequate centering at high speeds with a spring type of feel system.

An incidental result of the test was that the cam and roller type of device, shown in figure 1, was considered to be a poor means to provide a centering force. This device introduced relatively high friction forces in the control linkage which aggravated the problem of obtaining satisfactory centering. The device also caused the stick forces to be very sensitive to the effects of dirt or other small irregularities that might appear on the face of the cam.

Although the tests were limited to airspeeds below 300 miles per hour, some conclusions regarding the use of such a feel system on a transonic airplane can be made. It has been pointed out that the flexibility in the control system tended to make the stick-force variations more satisfactory. It is possible to imagine enough flexibility in the controls to make the feel entirely satisfactory below the transonic-speed range. However, if the airplane were flown in the transonic-speed range where the hinge moments of the elevator are likely to increase rapidly, or to change in an erratic manner, such flexibility in the control linkages could lead to large, detrimental changes in the control of the airplane. For instance, it might lead to an excessive increase

in the stick force required for trim as the transonic-speed range was entered. It would therefore appear necessary to make the linkage rigid for transonic airplanes.

If it is assumed that the control linkage is rigid, calculations show that, even with the 2-pound bobweight, the force per g would decrease to a value below the required minimum at some speed above 300 miles per hour. This difficulty might be overcome without resorting to a continuous variation of force gradient with dynamic pressure by varying the centering-spring constant in two or more steps throughout the speed range. Such an arrangement might involve less mechanical complication than the continuously variable system. With a higher spring constant, it would be possible to extend the satisfactory range of force per g for the feel system. For example, if the spring constant in the present system could be doubled at 400 miles per hour, the variation of force per g with airspeed would appear as shown in figure 10. Such an arrangement would extend the satisfactory range to 600 miles per hour.

The force per g of the bobweight is included in the calculated data of figure 10. It is not felt that the satisfactory range of the feel system could be extended by increasing the bobweight force. The pilot's opinion in the present test and the results of reference 5 indicate that it is necessary to have an adequate centering force as well as a satisfactory variation of force per g to have a satisfactory stick feel. For this added reason it would appear necessary to have a variable centering-spring constant as a step towards making the feel system satisfactory for a transonic airplane. To further insure adequate centering, it may be necessary to limit the friction in the control system to smaller values than are presently allowed.

CONCLUSIONS

Tests of some simple types of feel devices in the elevator system of a Chance Vought F4U-4B airplane equipped with a power control system have yielded the following conclusions:

1. A centering spring, which gave no variation of force gradient with impact pressure and was strong enough to give reasonable force per g values, was unsatisfactory because of the excessive stick forces encountered in landing.

2. With a preloaded spring included in the feel system to reduce the stick forces when landing and a bobweight included to increase the force per g, the elevator stick-force characteristics satisfied the minimum requirements over the limited speed range of the test airplane at the test center-of-gravity position.

3. The centering force provided by the feel system at high speeds was considered to be unsatisfactory.

4. Satisfactory elevator stick-force characteristics would be difficult to obtain with the centering-spring type of feel device on an airplane intended for transonic airspeeds.

Langley Aeronautical Laboratory
National Advisory Committee for Aeronautics
Langley Field, Va.

REFERENCES

1. Anon.: Evaluation of Irreversible Power Control and Simulated Feel System Installed in F4U-4B Airplane, Bu. No. 97392, Project TED No. PTR DE 315, Flight Test Div., U.S. Naval Air Test Center (Patuxent River, Md.), Feb. 2, 1950.
2. Mathews, Charles W., Talmadge, Donald B., Whitten, James B.: Effects on Longitudinal Stability and Control Characteristics of a B-29 Airplane of Variations in Stick-Force and Control-Rate Characteristics Obtained Through Use of a Booster in the Elevator-Control System. NACA TN 2238, 1951.
3. Andreoli, D. G.: Irreversible Control & Simulated Feel Systems: Description & Operating Instructions (E.P. 1098). Rep. No. 7684, Chance Vought Aircraft, Div. of United Aircraft Corp. (Stratford, Conn.), Sept. 23, 1948.
4. Anon.: Flying Qualities of Piloted Airplanes. U.S. Air Force Specification No. 1815-B, June 1, 1948.
5. Phillips, William H.: An Investigation of Additional Requirements for Satisfactory Elevator Control Characteristics. NACA TN 1060, 1946.

TABLE I
CHARACTERISTICS OF P4U-4B AIRPLANE

Weight, lb	12,676
Wing span, ft	40.98
Total wing area, sq ft	276.3
Root chord, ft	8.75
Tip chord, ft	5.94
Wing center section	NACA 23018
Wing tip section	NACA 23009
Incidence, deg	2
Dihedral (outer panel), deg	8.5
Stabilizer span, ft	16.5
Stabilizer maximum chord, ft	2.82
Stabilizer area, sq ft	28.6
Elevator area, sq ft	24.6
Fin area, sq ft	7.34
Rudder area, sq ft	14.7
Aileron area, sq ft	18.1
Flap area, sq ft	36.4
Engine - Pratt & Whitney	R-2800-18W
Propeller - Hamilton Standard	4 blade, constant speed



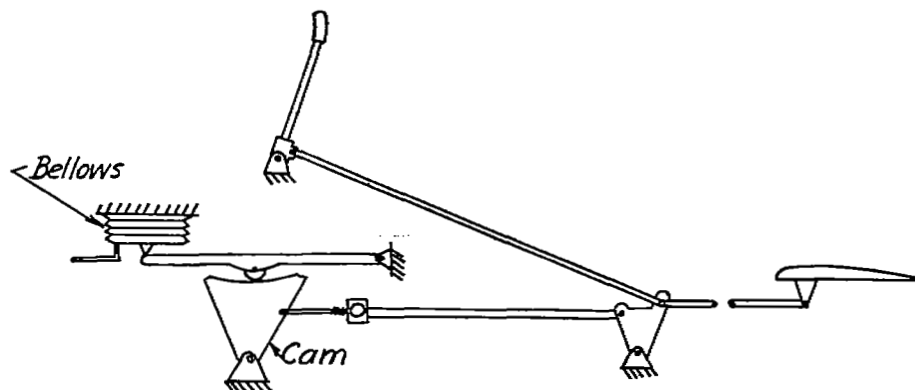

(a) Original feel system.

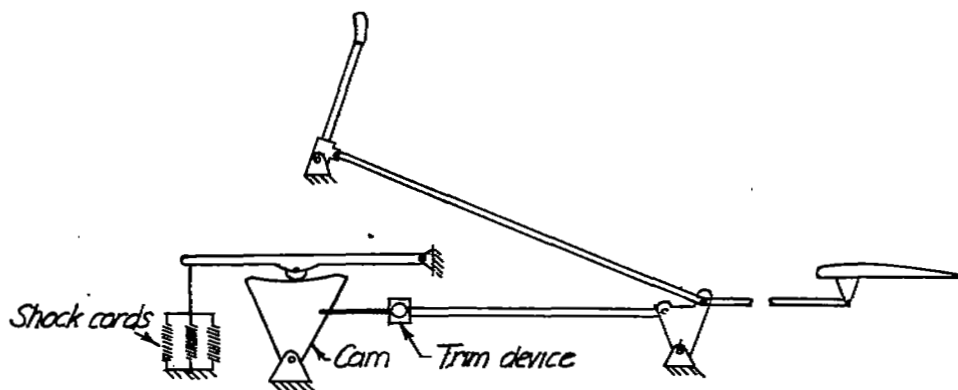

(b) Simple centering-spring feel system.

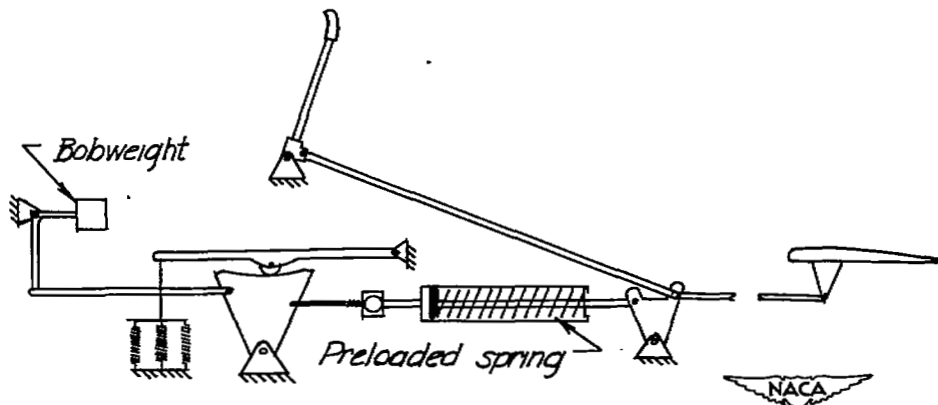

(c) Modifications to simple system.

Figure 1.- Sketch of the various feel systems installed in the Chance Vought F4U-4B airplane.

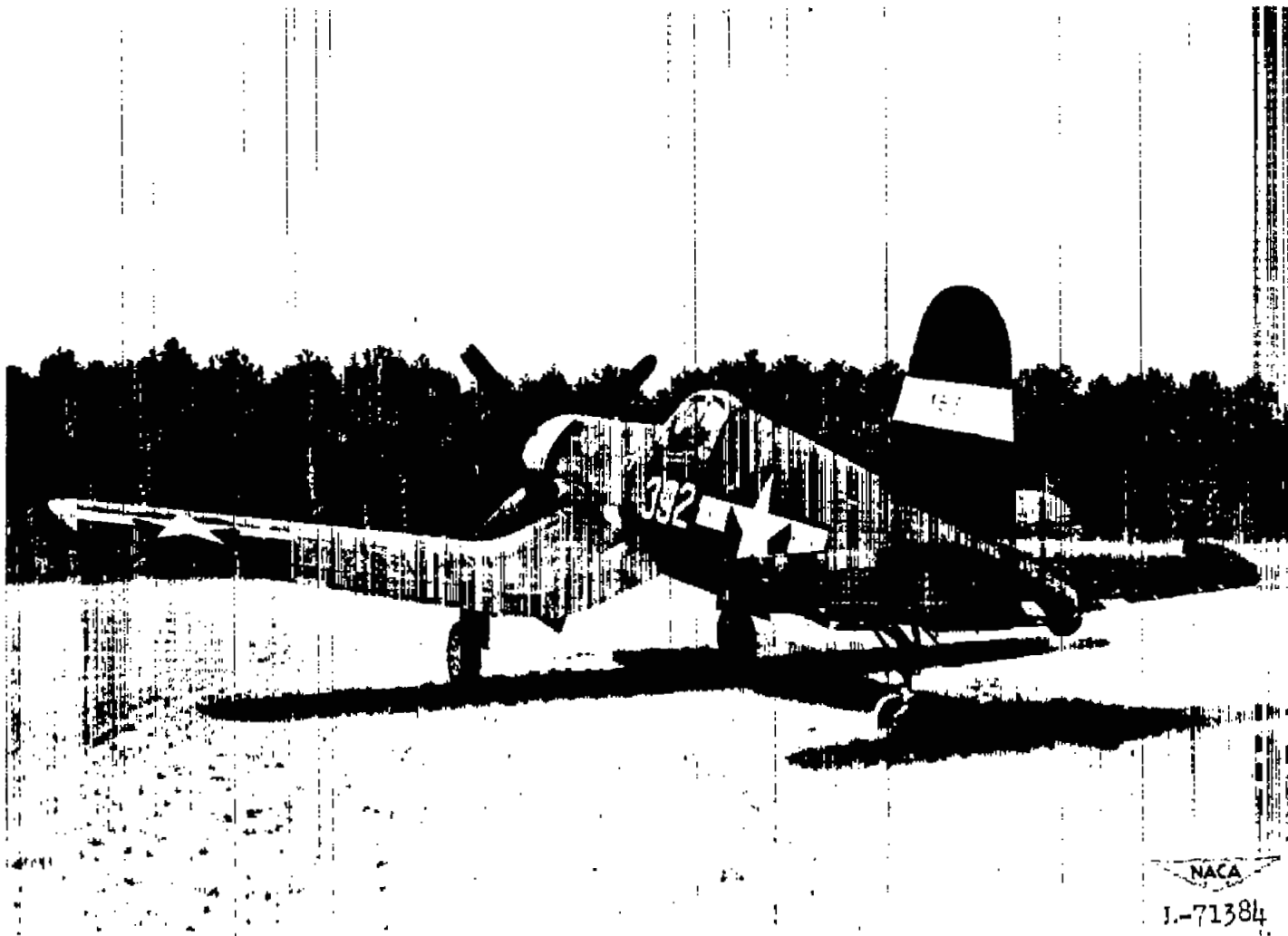

Figure 2.- The F4U-4B test airplane.

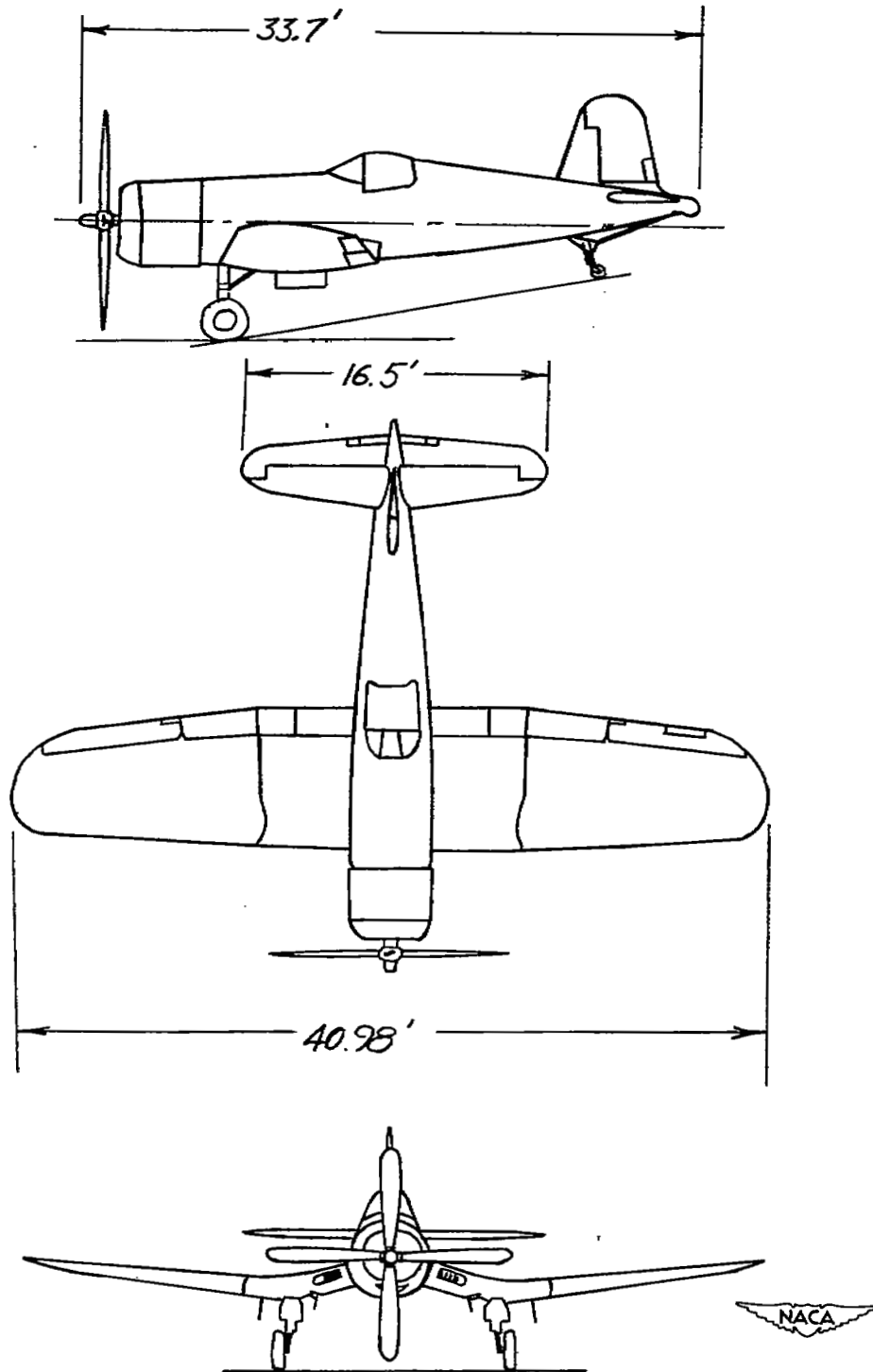

Figure 3.- Drawing of the F4U-4B airplane.

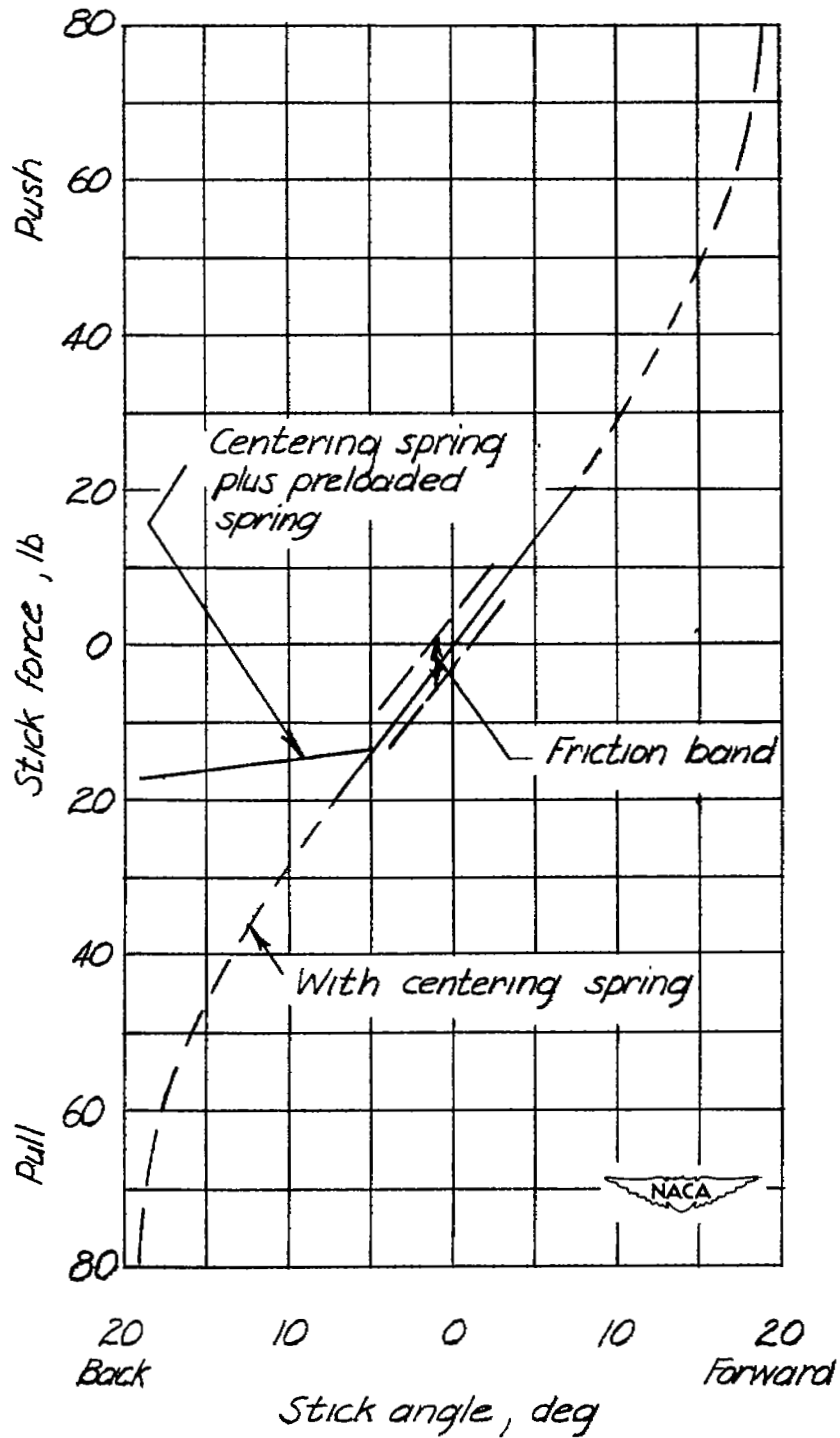

Figure 4.- Variation of the stick force with stick deflection for the various feel system arrangements.

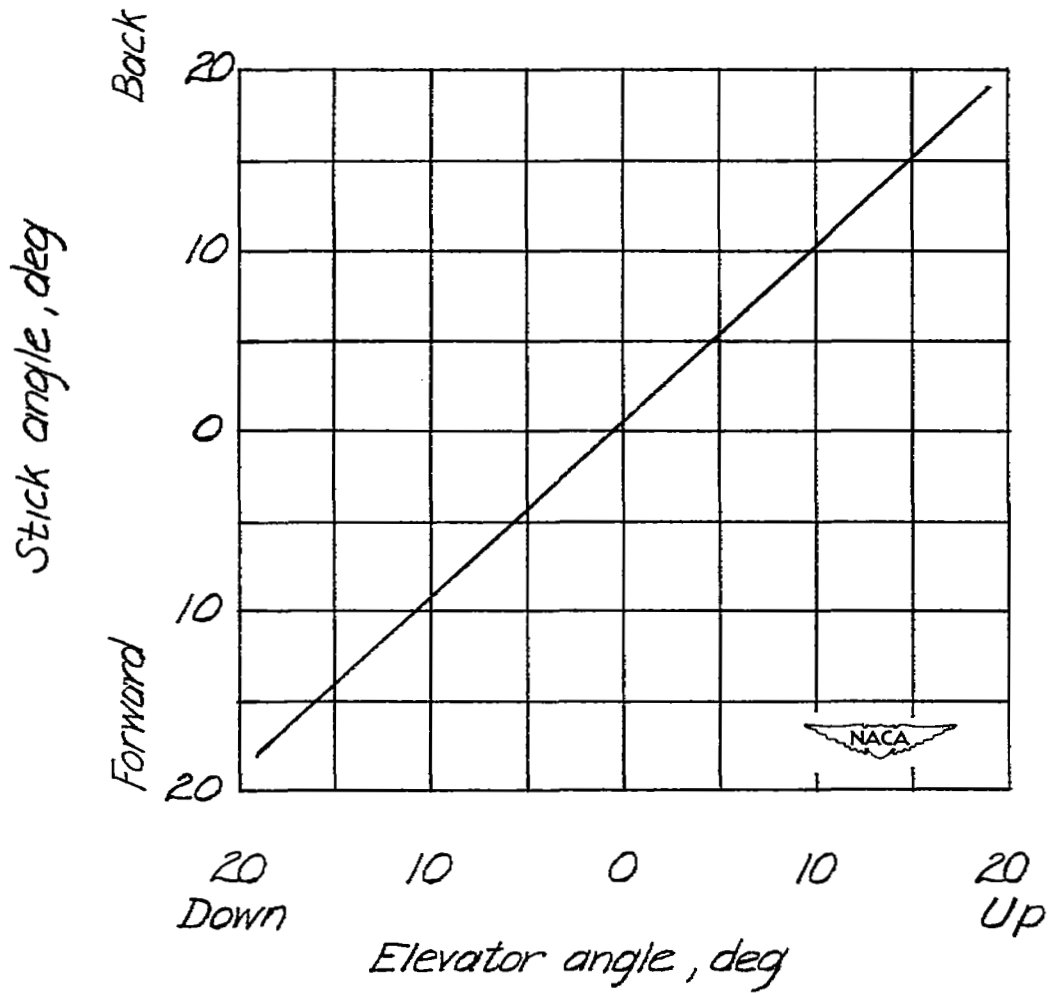

Figure 5.- Variation of stick angle with elevator angle for the F4U-4B airplane.

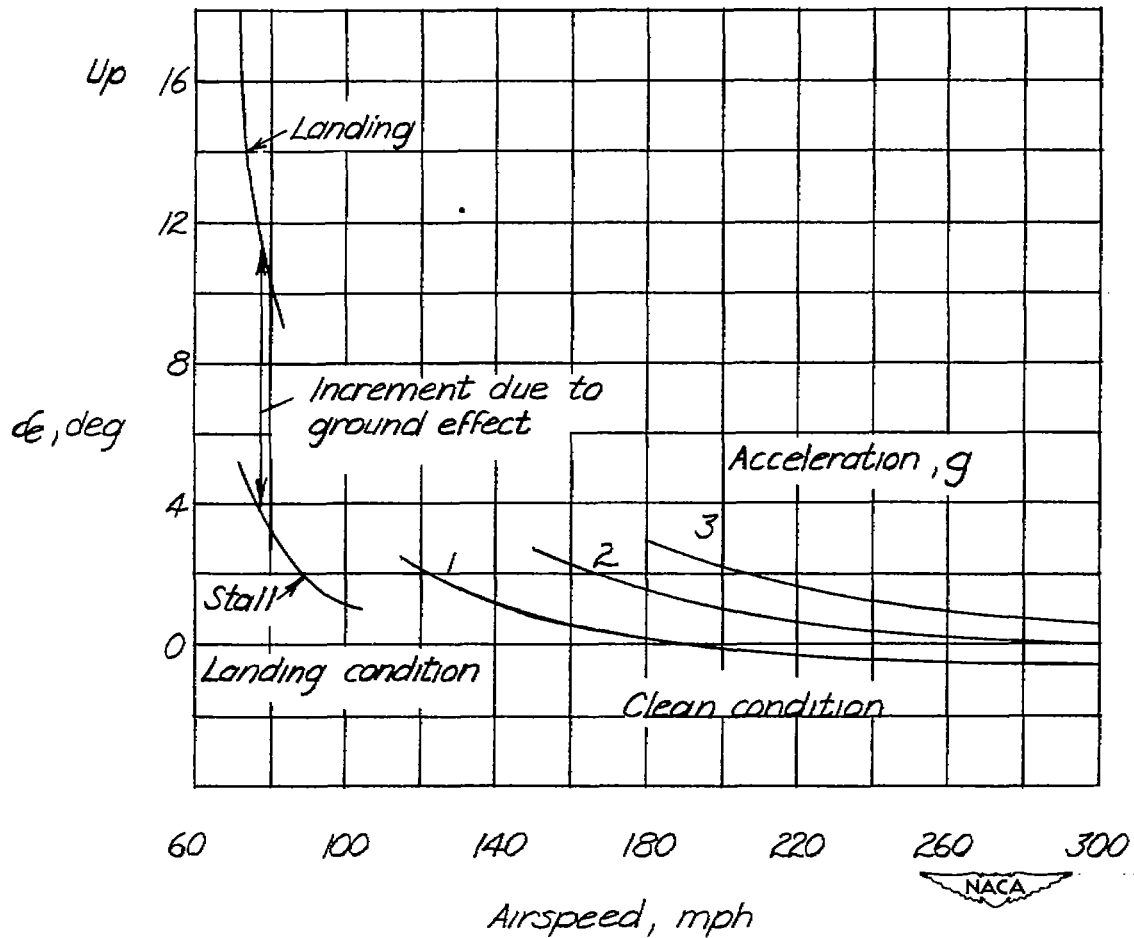
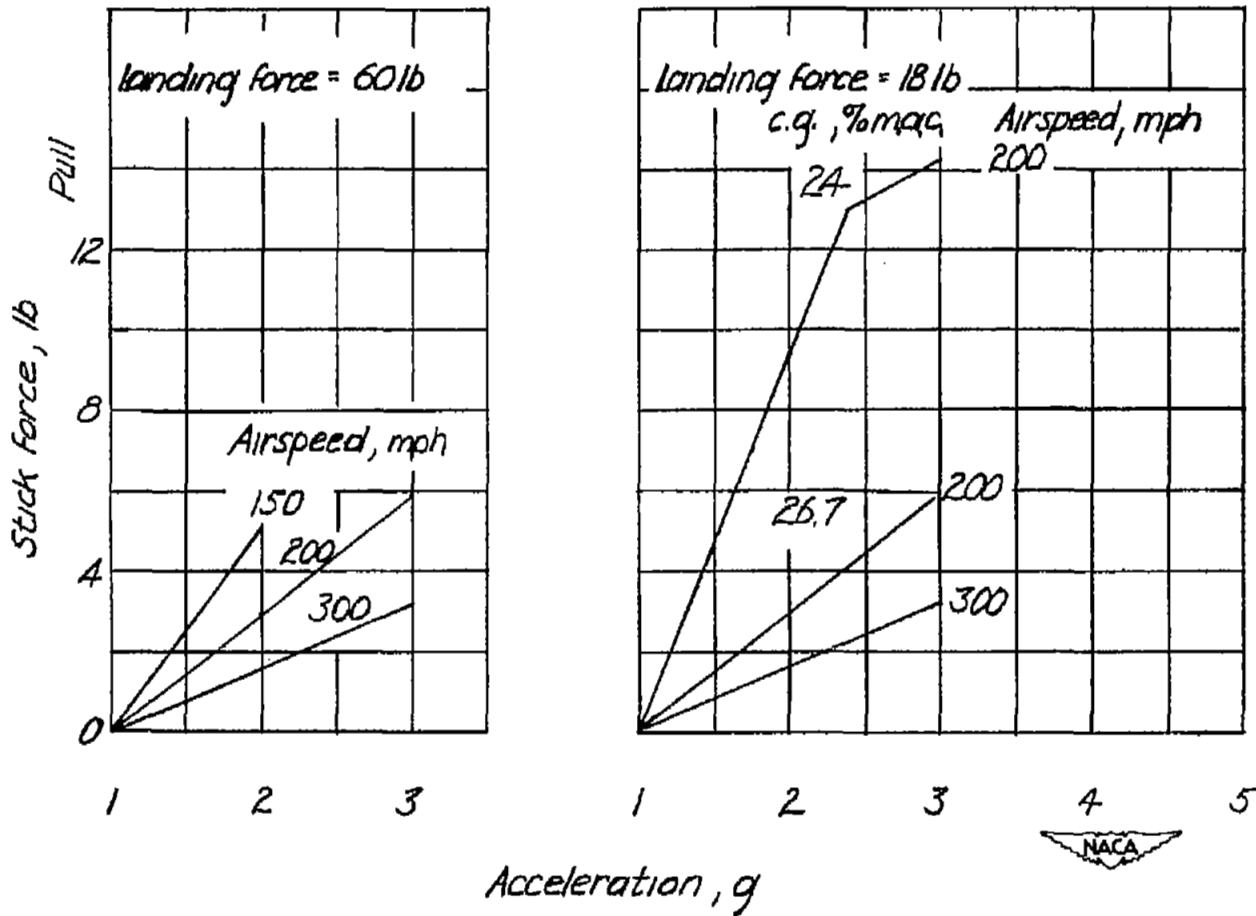

Figure 6.- Variation of elevator angle with airspeed and acceleration in the clean and landing conditions for the F4U-4B airplane. Center of gravity, 26.7 percent mean aerodynamic chord.



(a) Centering spring. Center of gravity, 26.7 percent mean aerodynamic chord.

(b) Centering spring plus preloaded spring.

Figure 7.- Calculated stick force characteristics with the various feel system arrangements in the F4U-4B airplane.

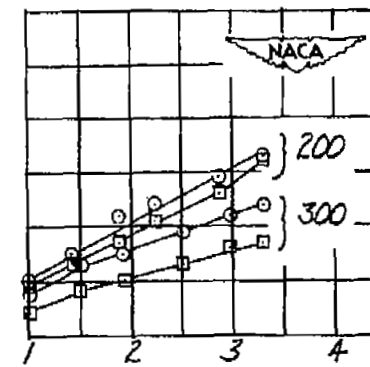
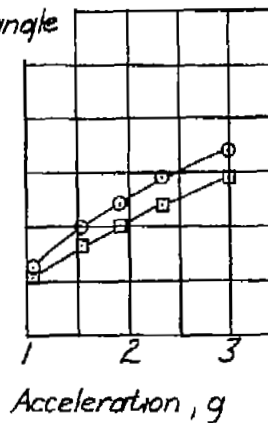
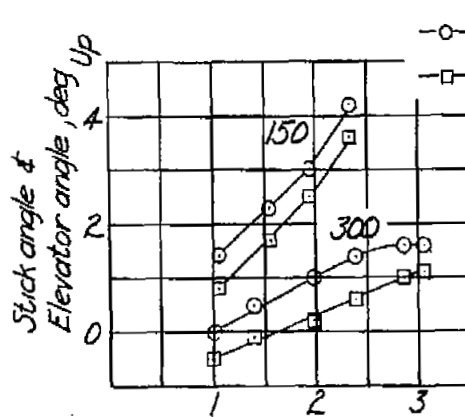
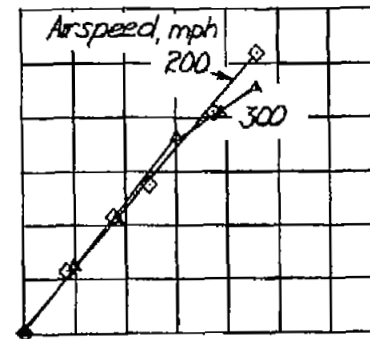
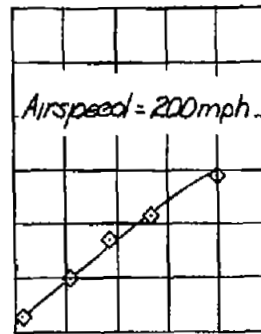
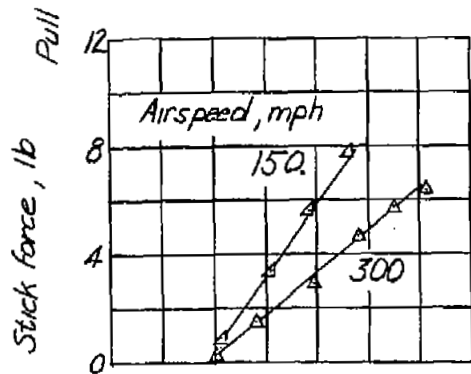

(a) Centering spring.

(b) Centering spring plus preloaded spring.

(c) Centering spring preloaded spring, and bobweight.

Figure 8.- Variation of stick force, stick position, and elevator position measured in flight with the various feel system arrangements in the F4U-4B airplane. Center of gravity, 26.7 percent mean aerodynamic chord.

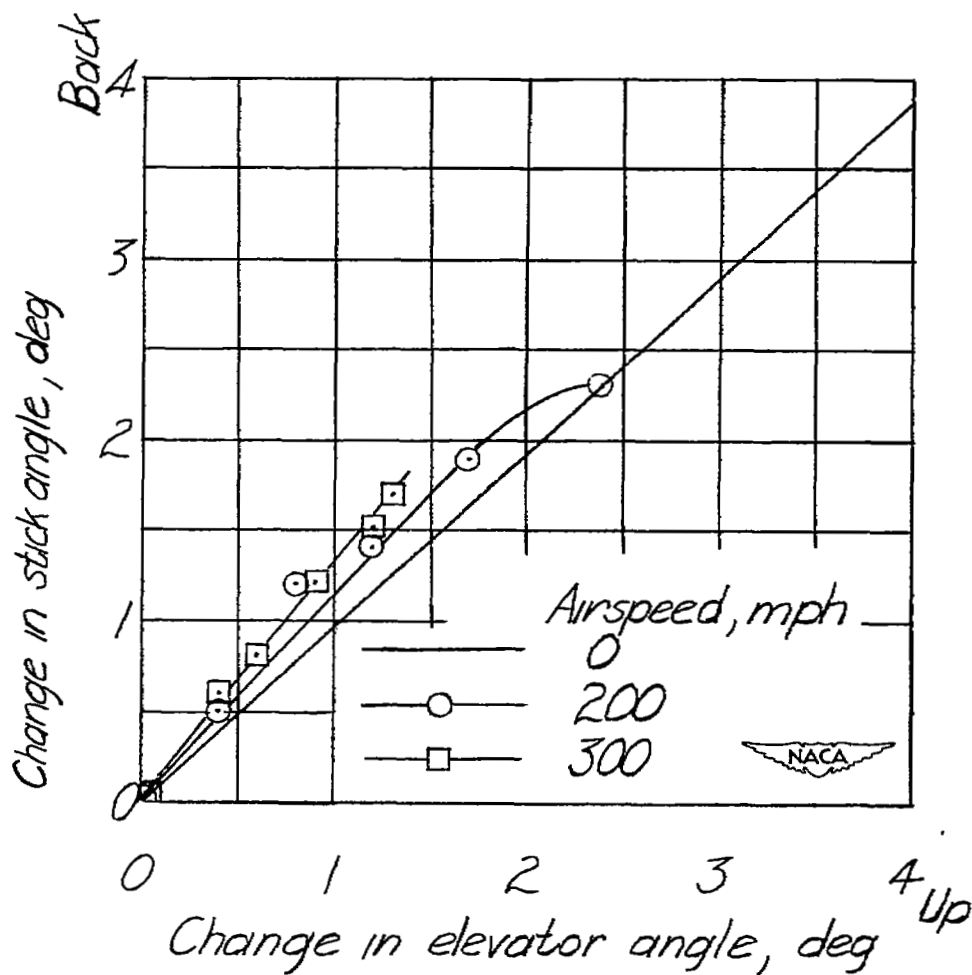

Figure 9.- Variation of elevator angle with stick angle at various airspeeds in the F4U-4B airplane.

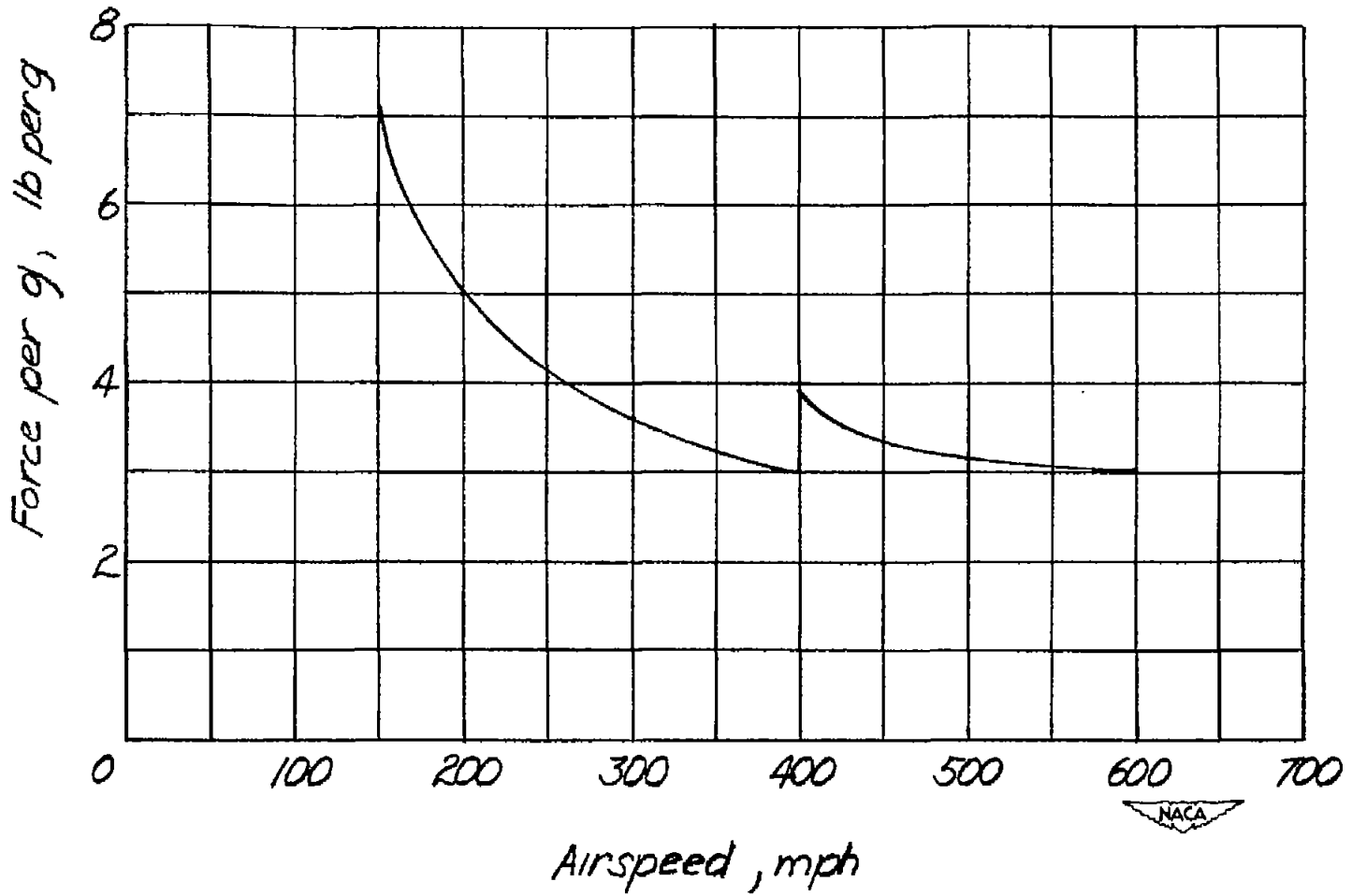

Figure 10.- Variation of stick force per g with airspeed for the centering-spring type of feel system with a variable spring constant and a 2-pound bobweight.

SECI

NASA Technical Library



3 1176 01436 4906

MATION

