

United States Court of Appeals for the Federal Circuit

2006-1535

SAFETCARE MANUFACTURING, INC.,

Plaintiff-Appellant,

v.

TELE-MADE, INC., MODERN MEDICAL SUPPLY,
GENDRON, INC., CONVAQUIP INDUSTRIAL, INC., and
CAMBRIDGE TECHNOLOGIES, INC.,

Defendants,

and

BURKE, INC.,

Defendant-Appellee.

John S. Egbert, Egbert Law Offices, of Houston, Texas, argued for plaintiff-appellant. With him on the brief was Paul S. Beik.

Michael L. Sturm, Wiley Rein & Fielding LLP, of Washington, DC, argued for defendant-appellee.

Appealed From: United States District Court for the Southern District of Texas

Judge Vanessa D. Gilmore

United States Court of Appeals for the Federal Circuit

2006-1535

SAFETCARE MANUFACTURING, INC.,

Plaintiff-Appellant,

v.

TELE-MADE, INC., MODERN MEDICAL SUPPLY,
GENDRON, INC., CONVAQUIP INDUSTRIAL, INC., and
CAMBRIDGE TECHNOLOGIES, INC.,

Defendants,

and

BURKE, INC.,

Defendant-Appellee.

DECIDED: August 3, 2007

Before MICHEL, Chief Judge, GAJARSA, Circuit Judge, and ROBINSON, District Judge.^{*}
GAJARSA, Circuit Judge.

Plaintiff SafeTCare Manufacturing, Inc. ("SafeTCare") brought this patent infringement action in the United States District Court for the Southern District of Texas, alleging that the defendants infringed SafeTCare's U.S. Patent No. 6,357,065 (the "'065 Patent"). The '065 Patent discloses a variable width bariatric modular bed that is particularly suitable for use by obese patients. SafeTCare appeals the district court's

^{*} Honorable Sue L. Robinson, District Judge, United States District Court for the District of Delaware, sitting by designation. District Judge Robinson served as Chief District Judge until July 1, 2007.

summary judgment decision holding that the bariatric bed designed and manufactured by Defendant Burke, Inc. (“Burke”) does not infringe the ’065 Patent. SafeTCare Mfg., Inc. v. Tele-Made, Inc. (“Summary Judgment Order”), No. 04-2306, slip op. (S.D. Tex. Jun. 14, 2006). Because Burke’s product does not infringe Claim 12, the only claim asserted, of the ’065 Patent, we affirm.

I.

A.

The written description notes that a “hospital bed is typically adjustable to control both mattress contour and height above the floor.” ’065 Patent col.1 ll.16-17. Bariatric beds have these same capabilities. “However, a bariatric bed is capable of lifting up to three times the weight of the typical hospital bed” and “is also wider than a standard hospital bed . . . so as to better support large (i.e. obese) patients.” Id. col.1 ll.35-40. The frame of the variable width bariatric modular bed disclosed in the ’065 Patent is reproduced below.

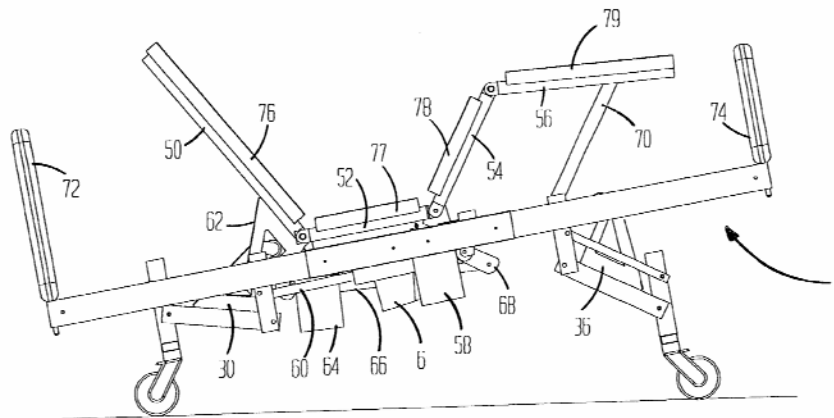

Id. Fig. 5.

SafeTCare asserts infringement only of Claim 12 of the ’065 Patent, which reads:

A bed comprising:
a frame;

- a plurality of deck sections pivotally connected to said frame to support a mattress, each of said plurality of deck sections having first and opposite sides and first and opposite pull out extensions slidable outwardly from said first and opposite sides between a retracted position at which said plurality of deck sections have a relatively narrow width by which to support a mattress having a correspondingly narrow width and an extended position at which said plurality of deck sections have a relatively wide width by which to support a mattress having a correspondingly wide width; and
- a plurality of electric motors carried by said frame and coupled to respective ones of said plurality of deck sections for exerting a pushing force on said plurality of deck sections for causing said deck sections to rotate upwardly relative to said frame so as to adjust the contour of the mattress.

Id. col.8 ll.31-50 (emphasis added).

B.

Burke manufactures and markets a bariatric bed named the Tri-Flex II. Burke agrees that “the movable deck panels on Burke’s Tri-Flex II bed are rotated relative to the frame by two electric motors, one for the head section and one for the foot section,” and that “the head section of the Tri-Flex II bed rotates upwardly relative to the frame through use of a motor exerting a pushing force.” Appellee Br. 13.

For the foot section of Burke’s Tri-Flex II bed, a motor is connected to the movable deck panel through an actuator and a lift dog. Specifically, when the foot section is in the lowered position, the movable deck panel lies horizontally above the bed frame. The motor is connected to the bed frame and located on a horizontal plane under the deck panel. A “lift dog,” which is a bracket attached or affixed to the deck panel,¹ extends

¹ The '065 Patent and the parties’ briefs use the term “lift dog” to describe a bracket attached or affixed to a movable deck section or lift assembly. For example, “lift dogs” 30 and 36 are affixed to their respective lift assemblies in the figure reproduced above from the '065 Patent. Col.3 ll.43-57. The movable deck panel for the head section has “lift dog” 62, and the movable deck panel for the thigh section has “lift dog” 68. Col.4

vertically from the deck panel down to the horizontal plane on which the motor is located. An actuator lies on the plane on which the motor is located and connects the motor with the lift dog. See J.A. 287-92, 514-15.

To raise the movable deck panel, the motor exerts a force that is translated through the actuator to pull the lift dog toward the motor. Because the deck panel is connected to the lift dog and to other components of the bed that are not discussed here, the motion of the lift dog toward the motor results in the deck panel rotating in an upward direction relative to the bed frame. See id.

SafeTCare did not dispute during oral argument the mechanical means of operation of Burke's Tri-Flex II bed. See Digital Audio Recording: Oral Argument in Case No. 2006-1535, at 11:47 (Mar. 8, 2007) ("Oral Argument"), <http://www.ca9.uscourts.gov/oralarguments/mp3/06-1535.mp3>.

C.

SafeTCare filed a complaint asserting infringement of its '065 Patent by seven different defendants: Tele-Made, Inc.; Burke; Cambridge Technologies, Inc. ("Cambridge Technologies"); ConvaQuip Industrial, Inc.; Modern Medical Supply; Kinetic Concepts, Inc.; and Gendron, Inc. Burke, along with several of the other defendants, asserted various counterclaims against SafeTCare.

The district court conducted a Markman hearing, where the parties agreed that the term "a pushing force" of Claim 12 of the '065 Patent means "a physical force applied in a direction away from the body exerting it." The district court subsequently issued an order construing the term in the same manner.

II.40-57. The district court did not construe and the parties do not dispute the meaning of the term.

Burke and Cambridge Technologies moved separately for summary judgment of noninfringement. In June 2006, the district court granted both motions. The district court then docketed what it asserted was a “Final Judgment,” stating, “for the reasons stated in the Court’s Orders granting Defendant Burke, Inc.’s and Defendant Cambridge Technologies, Inc.’s Motions for Summary Judgment . . . this action is DISMISSED.”

II.

As a threshold matter based on the district court’s “Final Judgment” order, this court is confronted with a case in which “the parties have failed to determine the finality of the appealed judgment.” Int’l Elec. Tech. Corp. v. Hughes, 476 F.3d 1329, 1330 (Fed. Cir. 2007). Here, SafeTCare filed a notice of appeal in July 2006 asserting that this court had jurisdiction over its appeal. Burke did not object to SafeTCare’s appeal. The district court, however, had not dismissed the claims and counterclaims relating to six of the defendants, including Burke’s counterclaim.

The Supreme Court has stated that “[f]ederal courts are courts of limited jurisdiction. They possess only that power authorized by [the] Constitution and statute, which is not to be expanded by judicial decree.” Kokkonen v. Guardian Life Ins. Co. of Am., 511 U.S. 375, 377 (1994) (citations omitted). Furthermore, “every federal appellate court has a special obligation to satisfy itself . . . of its own jurisdiction . . . even though the parties are prepared to concede it.” Bender v. Williamsport Area Sch. Dist., 475 U.S. 534, 541 (1986) (citation and internal quotation marks omitted). In other words, this court is required to determine whether subject matter jurisdiction over an appeal exists notwithstanding the parties’ belief or concession that we possess jurisdiction. Finally, “[i]t is to be presumed that a cause lies outside this limited jurisdiction, and the burden of

establishing the contrary rests upon the party asserting jurisdiction.” Kokkonen, 511 U.S. at 377 (citations omitted). Similarly, Federal Rule of Appellate Procedure 28 requires that an appellant establish the basis for this court’s jurisdiction on appeal. Therefore, reliance on an agreement of the parties or an absence of an objection by the appellee is insufficient and cannot vest a court with subject matter jurisdiction.

This court has appellate jurisdiction pursuant to 28 U.S.C § 1295(a)(1) only “from a final decision of a district court.” The Supreme Court established that “a ‘judgment’ or ‘decision’ is final for the purpose of appeal only ‘when it terminates the litigation between the parties on the merits of the case, and leaves nothing to be done but to enforce by execution what has been determined.’” Parr v. United States, 351 U.S. 513, 518 (1956) (internal citations omitted). Federal Rule of Civil Procedure 54(b) (“Rule 54(b)”) clearly explains that when more than one claim, counterclaim, cross-claim, or third-party claim is presented in an action or when multiple parties are involved:

In the absence of [a Rule 54(b) judgment], any order or other form of decision, however designated, which adjudicates fewer than all the claims or the rights and liabilities of fewer than all the parties shall not terminate the action as to any of the claims or parties, and the order or other form of decision is subject to revision at any time before the entry of judgment adjudicating all the claims and the rights and liabilities of all the parties.

Therefore, unless the district court enters an express Rule 54(b) judgment or unless the case falls into a “specific, and narrowly circumscribed, exception[] to th[e] general rule” of finality, Mercantile Nat’l Bank at Dallas v. Langdeau, 371 U.S. 555, 573 (1963), a statement by the district court that the judgment is final is by itself insufficient to establish this court’s appellate jurisdiction under § 1295(a)(1). For a judgment to be appealable to this court, the district court must issue a judgment that decides or dismisses all claims

and counterclaims for each party or that makes an express Rule 54(b) determination that there is no just reason for delay. In this case, because litigation on the merits remained pending in the district court, the parties' reliance on the district court's order labeled "Final Judgment" was misplaced. The judgment standing alone as issued by the district court was insufficient to establish dismissal of the entire action, and therefore it could not be the basis for providing this court with subject matter jurisdiction.

Accordingly, this court notified the parties before oral argument that they had failed to comply with Federal Rule of Appellate Procedure 28 and that there was no final decision providing for our appellate jurisdiction pursuant to § 1295(a)(1). See generally Hughes, 476 F.3d at 1329; Nystrom v. TREX Co., 339 F.3d 1347 (Fed. Cir. 2003). Thereafter, the district court entered a "final judgment nunc pro tunc, effective as of June 15, 2006, pursuant to Fed. R. Civ. P. 54(b)" regarding the granting of Burke's summary judgment motion for noninfringement. Only after the district court issued the Rule 54(b) judgment was this court vested with jurisdiction over the appeal pursuant to § 1295(a)(1). See State Contracting & Eng'g Corp. v. Florida, 258 F.3d 1329, 1334-35 (Fed. Cir. 2001) ("We elect to follow the majority of other circuits and hold that a premature notice of appeal ripens upon entry of a proper Rule 54(b) certification.").

III.

A.

Summary judgment is appropriate if "there is no genuine issue as to any material fact and . . . the moving party is entitled to a judgment as a matter of law." Fed. R. Civ. P. 56(c); see also Anderson v. Liberty Lobby, Inc., 477 U.S. 242, 247-48 (1986). "We review a district court's grant of summary judgment de novo. . . . In deciding whether

summary judgment was appropriate, we view the evidence in a light most favorable to the party opposing the motion with doubts resolved in favor of the opponent.” Ethicon Endo-Surgery v. U.S. Surgical Corp., 149 F.3d 1309, 1315 (Fed. Cir. 1998) (citations omitted).

A determination of patent infringement consists of two steps: (1) the court must first interpret the claim, and (2) it must then compare the properly construed claims to the allegedly infringing device. See Cybor Corp. v. FAS Techs., Inc., 138 F.3d 1448, 1454 (Fed. Cir. 1998) (en banc). Claim construction, the first step, is a matter of law that this court reviews de novo. Id. at 1456. Generally, the second step is a factual question that we review for clear error. Bai v. L & L Wings, Inc., 160 F.3d 1350, 1353 (Fed. Cir. 1998). However, factual inferences that are material to the grant of a summary judgment are not accorded such deference—they are reviewed to ascertain whether there is a genuine issue of material fact. Lemelson v. TRW, Inc., 760 F.2d 1254, 1260 (Fed. Cir. 1985).

B.

Claim 12 of the '065 Patent requires “a plurality of electric motors” that exert “a pushing force on said plurality of deck sections.” Col.8 ll.44-50. It is undisputed that Burke’s Tri-Flex II bed has one motor that exerts such “a pushing force” on the deck panel in the head section. The parties, however, dispute whether the motor that raises the deck panel in the foot section exerts “a pushing force” and thus whether Burke’s Tri-Flex II bed has the plurality of motors required by Claim 12.

In the Markman claim construction order, the district court construed the term “a pushing force” to mean “a physical force applied in a direction away from the body exerting it.” In the summary judgment decision, the district court restated this construction and found that “it is undisputed that the foot section motor operates in pull

(exertion of a force towards itself), not in push (exertion of a force away from itself) as claimed in the '065 Patent.” Summary Judgment Order, slip op. at 8-9.

In the briefs and at oral argument before this court, the parties agreed that there is no dispute that the plain and ordinary meaning of “a pushing force” is “a physical force applied in a direction away from the body exerting it.” The mechanical means of operation of Burke’s Tri-Flex II bed was also undisputed. Yet the parties continued to disagree as to the district court’s ultimate holding of noninfringement.

To understand the source of the disagreement, the parties’ arguments must be understood in the context of the allegedly infringing device. Burke focuses on the force applied to the lift dog that is attached or affixed to the deck panel. To raise the movable deck panel, the motor exerts a force that is translated through the actuator to pull the lift dog toward the motor. SafeTCare focuses on the deck panel’s rotation in an upward direction relative to the bed frame. By inference, based on the deck’s rotation upward, there must be an upward force on the deck panel. Because the motor is located on a horizontal plane under the deck panel, the upward force illustrated by the raised deck panel is “away” from the motor. We agree with both factual descriptions, for the evidence demonstrates that the force exerted by the motor in Burke’s Tri-Flex II bed results in multiple forces applied to the deck panel. By analogy, pulling one side of a lever down results in multiple forces on the lever, including an upward force on the opposite side.

Therefore, this dispute does not present a factual question. Rather, the critical question is one of claim construction: whether the limitation in Claim 12 of a motor “exerting a pushing force on said . . . deck section” includes within its scope a motor that indirectly exerts a force on the deck section and away from the motor.

SafeTCare asserts that Claim 12 includes any motor that “appl[ies] a physical force to the deck sections that cause the deck sections to lift upwardly” and away from the motor. Conceding during oral argument that motors rotate and that their force must be translated through an actuator, Burke asserts that the motor must exert a pushing force through the actuator directly against the lift dog or the deck panel. Thus, accordingly to Burke, Claim 12 does not include a motor that exerts a pulling force through the actuator directly against the lift dog or the deck panel. Oral Argument 31:18.

We agree with both parties on one aspect of their interpretation of Claim 12—that Claim 12 does not require that the motor exert a force directly on the deck section because Claim 12 contemplates intermediates between them. The language of Claim 12 states only that the motor must be “coupled” with the deck section. ’065 Patent col.8 ll.44-50. This conclusion is supported by other portions of the patent. For example and in contrast to Claim 12, the patentee used the term “connected” in Claim 18, thereby indicating a more direct link between the force and the portion of the bed to which the force is applied. Id. col.10 ll.5-11 (stating that the motor “is connected to the front end section of said frame”). Similarly, the written description discusses the invention as having a motor shaft extending from a motor and pivotally connected to a lift dog, which is affixed to a deck section. See id. col.3 ll.49-57, col.4 ll.40-51, Fig. 5.

Nonetheless, we conclude that the specification precludes SafeTCare’s broad interpretation. In explaining the importance of referring to the specification in determining and understanding the meaning and scope of a patent claim, we have stated that “the specification ‘is always highly relevant to the claim construction analysis. Usually, it is dispositive; it is the single best guide to the meaning of a disputed term.’” Phillips v. AWH

Corp., 415 F.3d 1303, 1315 (Fed. Cir. 2005) (en banc) (quoting Vitronics Corp. v. Conceptronic, Inc., 90 F.3d 1576, 1582 (Fed. Cir. 1996)). Furthermore, “the specification may reveal an intentional disclaimer, or disavowal, of claim scope by the inventor. In that instance as well, the inventor has dictated the correct claim scope, and the inventor’s intention, as expressed in the specification, is regarded as dispositive.” Id. at 1316.

In this case, despite the fact that Claim 12 makes no mention of actuators or lift dogs, the patentee repeatedly emphasized its invention as applying pushing forces as opposed to pulling forces against the lift dogs. For example, in the Background section of the '065 Patent, the written description describes the prior art as having “electric motors [that] are known to apply a pulling force on structural members attached to the bed frame.” Col.1 ll.53-56 (emphasis added).

In distinguishing its patent from the prior art that was “known to apply a pulling force on structural members,” the patentee disclosed in the Summary of the Invention that its invention uses motors that apply pushing forces against lift dogs, which are attached to the movable deck sections:

A pair of electric motors are carried by the middle frame section and are pivotally coupled to lift dogs attached to the front end and rear end frame sections. The electric motors apply pushing forces against the lift dogs to cause either the front end frame section or the rear end frame section or the entire frame to be lifted relative to the floor. A third electric motor carried by the middle frame section is coupled to a lift dog attached to a head mattress support deck section, and a fo[u]rth electric motor also carried by the middle frame section is coupled to another lift dog attached to a thigh mattress support deck section. The third and fourth electric motors apply pushing forces against the lift dogs to cause the head and thigh mattress support deck sections to rotate upwardly relative to the frame to establish a variable and comfortable mattress contour for a patient. . . . The pushing (as opposed to pulling) forces applied by the electric motors to raise the frame and the mattress support deck

sections avoid possible injury to a patient in the event that one of the motors should break.

Col.2 ll.7-30 (emphasis added). The patentee made similar statements in the Detailed Description, which describe the invention's motors as applying forces against lift dogs:

As an important feature of the present invention, each of the shafts 28 and 34 of bed lift motors 6 and 8 apply pushing forces against their respective lift dogs 30 and 36 to cause the bed frame 1 to be lifted as needed to correspondingly elevate a mattress. This is in contrast to conventional bed frames in which lift motors exert a pulling force against the frame to cause the frame to be lifted and a mattress to be elevated.

'065 Patent col.3 ll.58-65 (emphasis added).

It may be appreciated that like the bed lift motors 6 and 8, the head and thigh mattress support deck section lift motors 58 and 64 generate pushing forces via their respective shafts 60 and 66 against the head section lift dog 62 and the thigh section lift dog 68 to cause the head and thigh mattress support deck sections 50 and 54 to be rotated upwardly.

Id. col.4 ll.51-57 (emphasis added).

We “recognize that the distinction between using the specification to interpret the meaning of a claim and importing limitations from the specification into the claim can be a difficult one to apply in practice.” Phillips, 415 F.3d at 1323. In this case, however, we are not in danger of importing any limitations from the specification into Claim 12. Rather, we rely on the specification merely to understand what the patentee has claimed and disclaimed. Id. at 1316 (finding “the inventor’s intention” to be “expressed in the specification”). In this case, the written description repeatedly emphasizes that the motor of the patented invention applies a pushing force, not a pulling force, against the lift dog. The inventor makes clear that this attribute of the invention is important in distinguishing

the invention over the prior art. Thus, we are persuaded by the language used by the patentee that the invention disclaims motors that use pulling forces against lift dogs.

It is undisputed in this case that the motor at issue in Burke's Tri-Flex II bed exerts a force that is translated through the actuator to pull the lift dog toward the motor. As described by the patentee in the statements included above, the patentee disavowed such motors from the limitation in Claim 12 covering motors "exerting a pushing force on . . . deck sections." We follow Phillips and hold that the patentee's disavowal of such motors in the specification is dispositive. Therefore, we agree with the district court's summary judgment decision finding that Burke's Tri-Flex II bed does not literally infringe Claim 12 of SafeTCare's '065 Patent.

We similarly agree with the district court's holding of no infringement under the doctrine of equivalents. "There can also be no infringement under the doctrine of equivalents because the accused" device exerts a force that is translated through the actuator to pull the lift dog toward the motor, and such a force was "disavowed from the scope of the '[pushing force]' limitation, as we have discussed above." Honeywell Int'l, Inc. v. ITT Indus., Inc., 452 F.3d 1312, 1321 (Fed. Cir. 2006).

IV.

For the foregoing reasons, we affirm the summary judgment decision of the district court.

AFFIRMED

Each party shall bear its own costs for this appeal.