

Manual of Instruction for the Safe Use of Reproduction Nineteenth Century Artillery in Historic Weapons Demonstrations

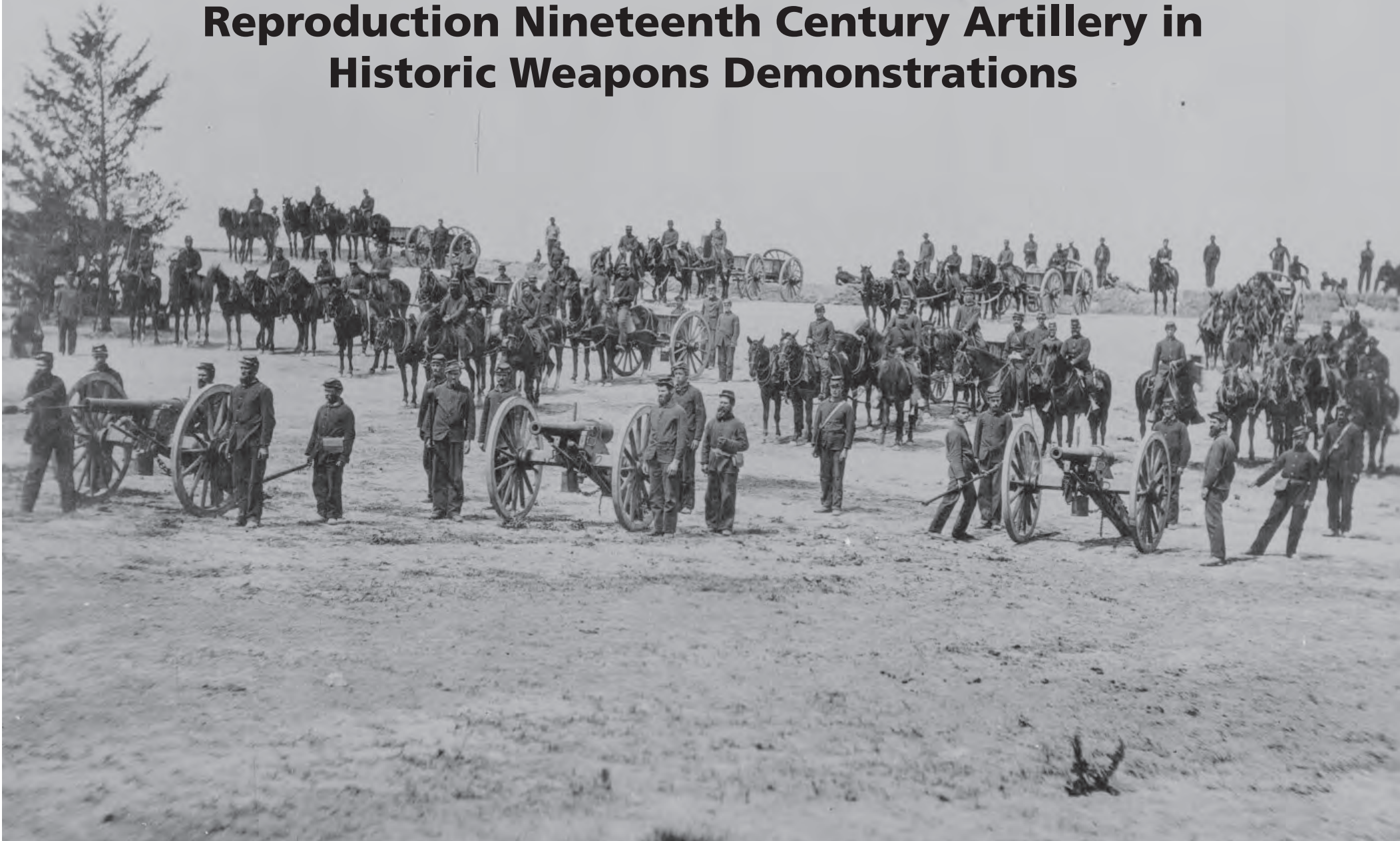

TABLE OF CONTENTS

	Page
Part I: Introduction	1
Part II: Artillery Nomenclature	2
Part III: Artillery Inspection and Maintenance	8
Part IV: Artillery Drill	15
Part V: Artillery Misfires Procedures	49
Part VI: Artillery Laboratory	59
Part VII: Artillery Demonstration Critique	68
Part VIII: Artillery Competency Examination	70
Appendix A - Manual of the Piece from Instruction for Field Artillery (1860)	74
Appendix B - Commands for Battery Firing	89
Appendix C - Drill Manual for the Model 1841 Mountain Howitzer	92
Appendix D - Drill for the 30-Pounder Parrott Rifle	106
Bibliography	109

PART I - INTRODUCTION

The four primary causes of accidents in historic weapons demonstrations using artillery are:

1. Rapid Firing
2. Poorly Maintained or Improper Equipment
3. Improper Drill
4. Improper Ammunition

This manual sets forth the procedures that must be followed by persons demonstrating 19th century field artillery to the public in areas administered by the National Park Service. It also provides instruction on proper maintenance, inspection and repair procedures. This manual must be used in conjunction with Director's Orders, DO-6, Historic Weapons Demonstration Safety Standards and the Historic Weapons Program Manual.

Once an individual has completed training based on this manual. He/she will be able to perform historic weapons demonstrations that meet all NPS regulations and avoid all four of the primary causes of artillery accidents. This manual addresses basic nomenclature, equipment maintenance, ammunition manufacture, and drill. For additional interpretive information see the 19th Century Historic Weapons Reference Manual.

The material in this manual was originally written and compiled by former National Park Service Historian Daniel Brown in 1977. Dan possesses an extensive background and years of experience in the subject and the many hours he spent on this publication are greatly appreciated.

The material in this manual was updated in 2008 to meet current training and certification needs of the National Park Service.

PART II - ARTILLERY NOMENCLATURE

THE GUN

1. The bore is the interior hollow cylinder which receives the charge. It includes all the part bored out.

2. The muzzle is the entrance to the bore.

5. The reinforce is the thickest part to the body of the gun to offer resistance to the force of the powder and the shock of the projectile.

6. The chase is the conical part of the gun in front of the reinforce.

9. The trunnions are the cylinders at the sides of the gun, which support it on its carriage.

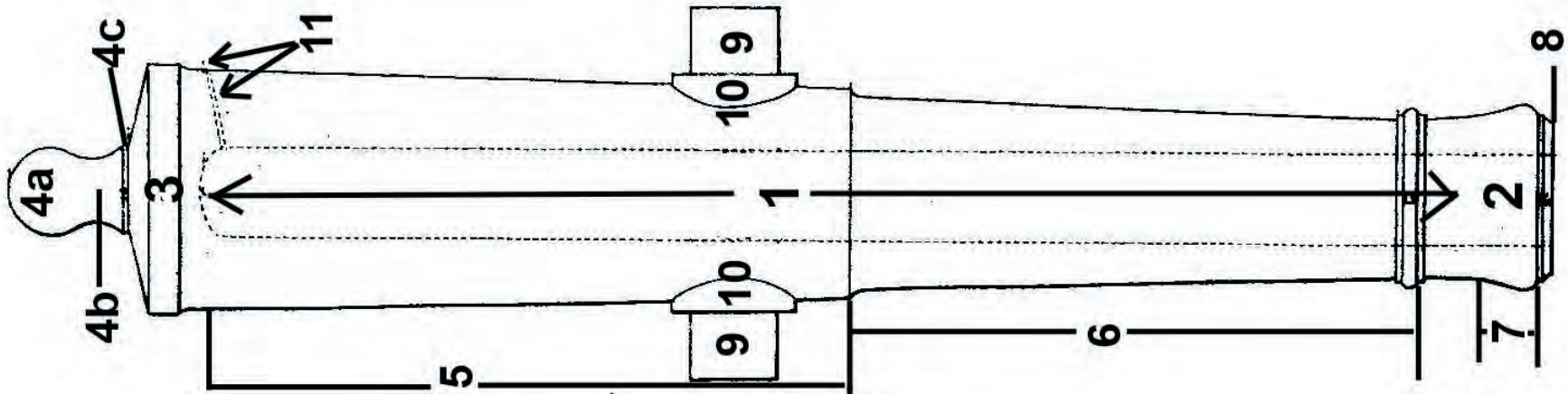

3. The breech is the mass of solid metal between the bottom of the bore and the cascable. The seat for the hausse is behind the base of the breech.

4. The cascable is the projecting part which terminates the piece. It consists of the knob(a), the neck(b) and the fillet(c).

7. The swell of the muzzle is the large part of the gun in front of the neck; it gives strength to the gun at its termination to prevent the mouth from splitting from the shocks of the projectiles, and facilitates aiming. The muzzle sight is screwed into it.

8. The face is the front plane terminating the piece.

10. The rimbases are the short cylinders uniting the trunnions with the body of the gun.

11. The vent is a cylindrical hole, terminating near the bottom of the bore, through which fire is communicated to the charge. It is bored through a vent piece made of wrought copper, which is screwed into the gun.

THE HOWITZER

The nomenclature of the howitzer is essentially the same as the gun with the exception of a chamber at the breech to allow for the firing of heavy projectiles with light charges.

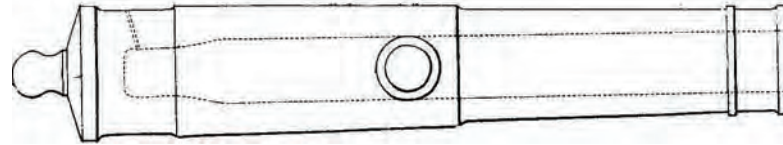

THE CARRIAGE

Carriage parts made of white oak are:

1. The cheeks are two pieces of wood between which the gun rests.
2. The stock is squared wood, in two pieces, joined to the cheeks and serving to connect the two parts of the carriage together.
3. The trail is the curved part of the stock, which rests on the ground when the piece is in battery.
4. The axle body covers the axletree.
5. The wheels consist of the nave(a), spokes(b) and felloes(c).

Carriage part(s) made of brass are:

6. The elevating screw box receives the elevating screw.

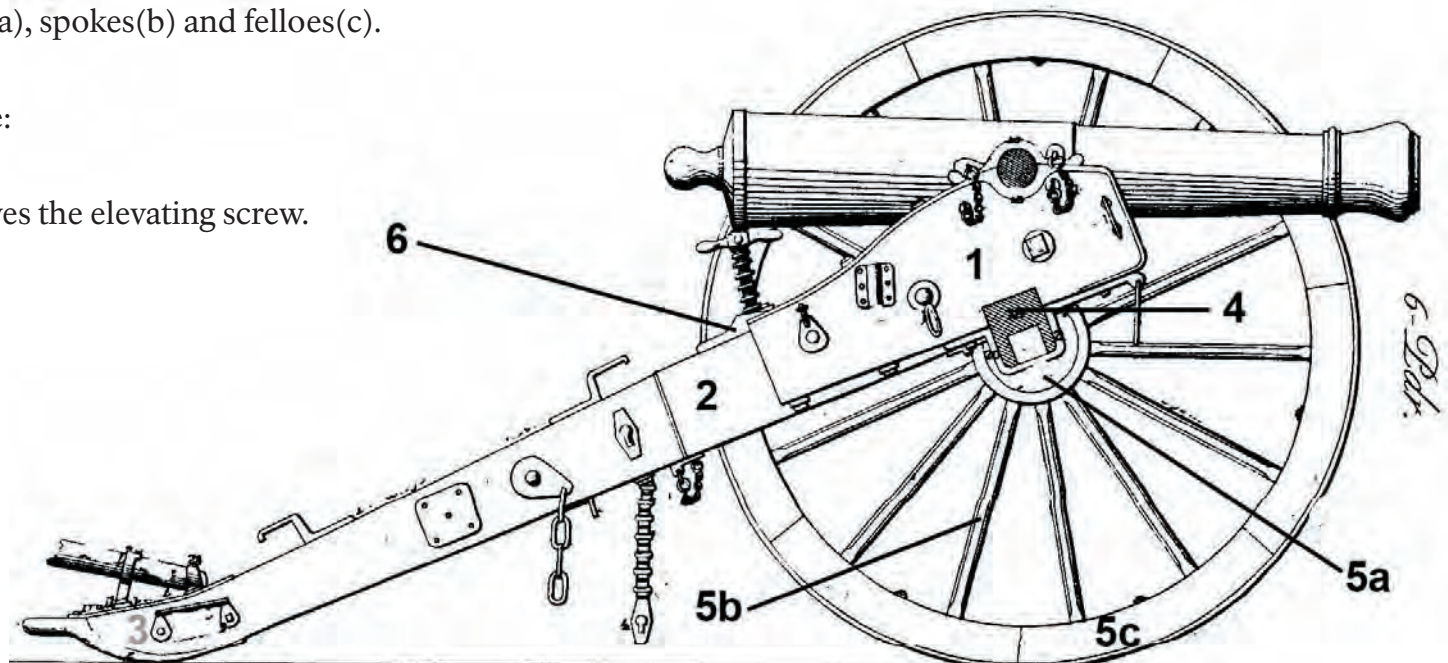

Carriage parts made of iron are:

7. The trail plate is attached to the stock-trail and contains a stout ring, called the lunette, which receives the pintle hook of the limber
8. The large pointing ring and small pointing ring receive the handspike and are used to aim ("point") the piece.
9. The trail handles are bolted to the sides of the trail and are used to lift it.
10. The wheel guard plates protect the stock from the limber wheels.
11. The prolonge hooks are nailed to the upper surface of the stock and are used to secure the prolonge.
12. The lock chain is placed on the side of the carriage. It serves to keep the wheel from turning.
13. The sponge and rammer stop is located under the stock to keep the sponge rammers from sliding.
14. The sponge rammers are held in place by two sponge chains.
15. The hasp of the sponge chain locks over the ear plate mortised into the side of the stock.
16. An ear plate, key and chain supports the worm.
17. The elevation screw is used to raise and lower the breech. It consists of the head and handles.
18. The trunnion plate protects the cheeks.
19. The cap squares are placed over the trunnions to hold them in place. They are fastened by chains, pins and keys.
20. The rondels are spacers between the cheeks and the stock. They are held in place by bolts.
21. The washer hooks for the handspike and the lock chain are attached to the bolts.
22. The handspike rings support the handspikes. They are stapled to the cheeks.
23. The understraps are bolted to the cheeks and under the stock.
24. On the left and right understrap are implement hooks which support the sponge rammers and the worm. The center understrap has a hasp where the toggle on the sponge bucket is attached.
25. The wheel is attached to the axletree by means of a linch pin and washer. The washer prevents the pin from cutting into the nave.
26. The nave is reinforced by the nave bands.
27. The wheel is mounted with a tire.

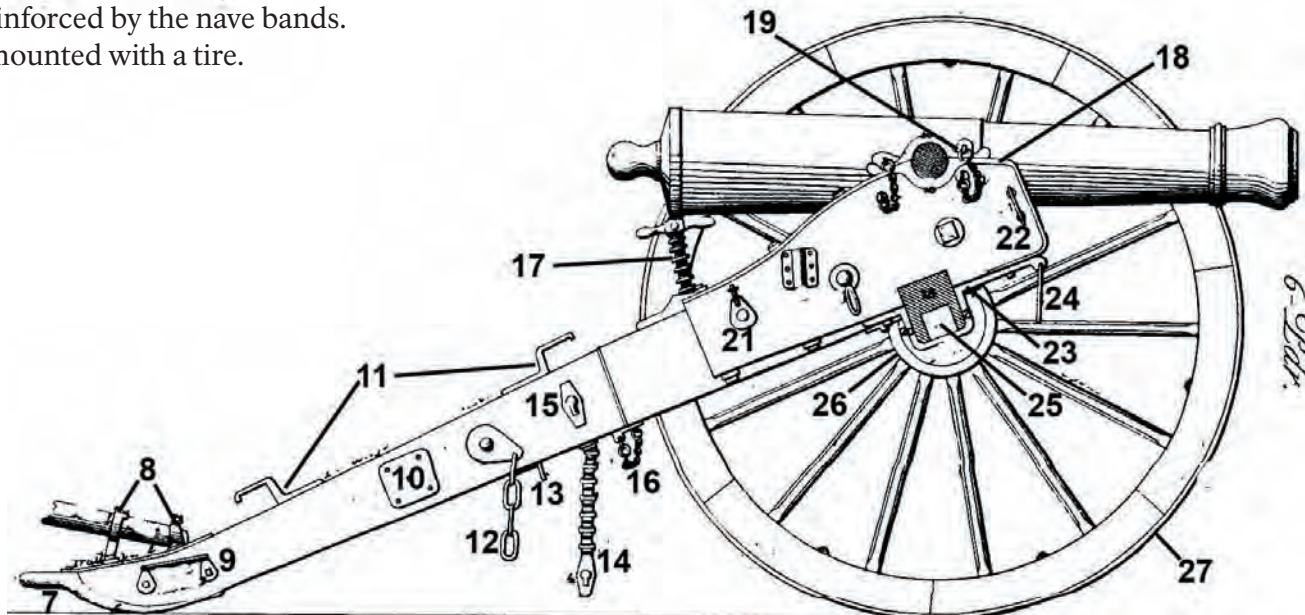

IMPLEMENTS

1. The sponge rammer consists of the sponge head, the rammer head, staff and sponge.
 - The staff is made of ash or hardwood.
 - The sponge head is made of elm or poplar and held in place by dowels.
 - The rammer head is made of ash or elm and is held in place by dowels.
 - The sponge is made of oak-tanned saddle shearling or all-wool Brussels carpet.
 - The sponge is attached to the sponge head by means of copper or brass nails and a leather washer.
2. The worm staff is made of ash or hardwood and is mounted with a worm made of iron.
3. The sponge bucket is made of iron with a tarred interior. It consists of a lid (hardwood), handle, toggle and chain.
4. The tube pouch is made of leather.
5. The thumb-stall is made of buckskin. A small pad is filled with horsehair.
6. The priming wire is made of brass.
7. The lanyard includes a wooden toggle, cord and iron hook.
8. The gunner's haversack is made of leather.
9. The trail handspike is made of hickory or oak and consists of a ring and staple, and key made of iron.

THE LIMBER

1. The axle body(a) is the wooden part in which the axle tree(b) is placed.
2. The hounds are pieces of wood connecting the body of the axle to the splinter bar, and upon which the ammunition chest rests.
3. The fork is a piece of wood between the hounds, and forms an opening in which the pole is placed.
4. The pole is held in place by a bolt and serves for hitching the wheel horses with the pole yoke.
5. The branches of the pole yoke are attached by means of sliding rings to the collars of the wheel horses, and support the pole.
6. The splinter bar serves for hitching the wheel horses with four trace hooks.
7. The foot boards are screwed to the hounds and the forks and are used when the cannoneers are mounted on the limber.
8. The pintle hook, on the hind part of the limber axletree serves to unite the limber to the carriage, and has a key and chain.
9. The pole prop is used to support the limber. It is put up by a chain and toggle.

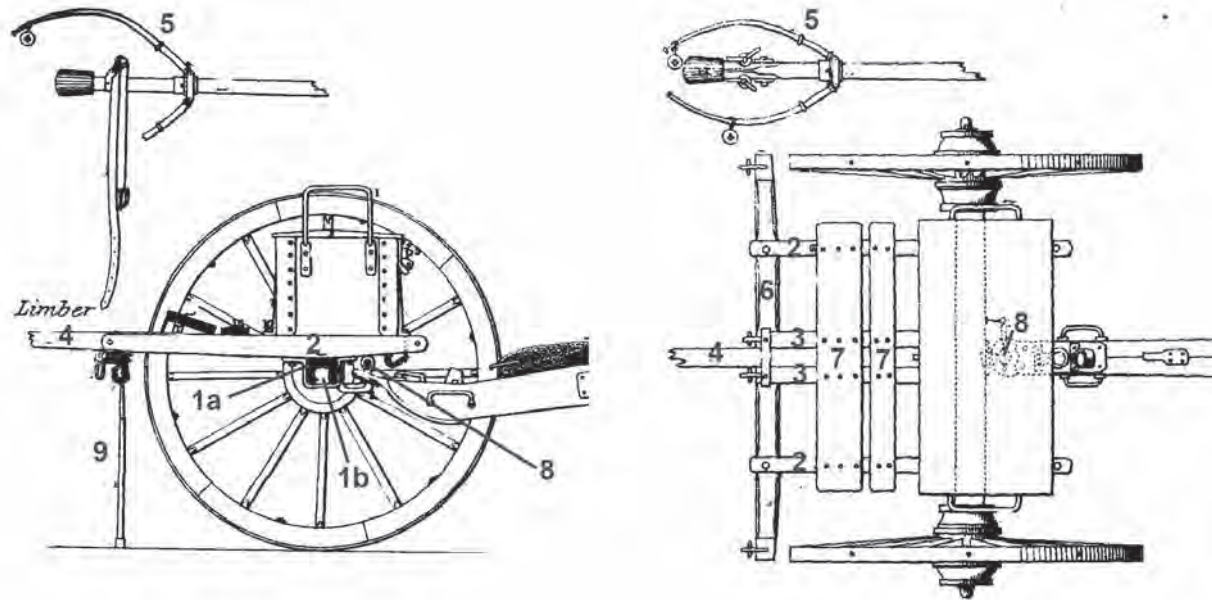

THE AMMUNITION CHEST

The ammunition chest is made of walnut. Due to the exigencies of service during the Civil War, many were made of cherry.

10. The handles are used to move the chest.

11. The cover (or lid) is covered with copper sheeting and is nailed in place.

12. Two hinges (a), a turnbuckle and hasp (b) secure the cover to the chest.

13. The corner plates protect the corners of the chest.

14. The front plate protects the chest from an accident involving the lunette.

15. The chest is held in place on the limber by means of a stop on the back strap (a), and two front straps(b), with stay pins and keys(c).

16. In the interior of the chest is a tray (poplar) with three finger holes to facilitate removal. A hole is bored into the bottom of the tray to let air pass when the tray is lifted out.

17. The chest is divided into the left half and the right half. The halves are further separated into divisions. Ammunition is placed in the divisions. The partitions (poplar) are held in place by bolsters (poplar) which are screwed into the chest.

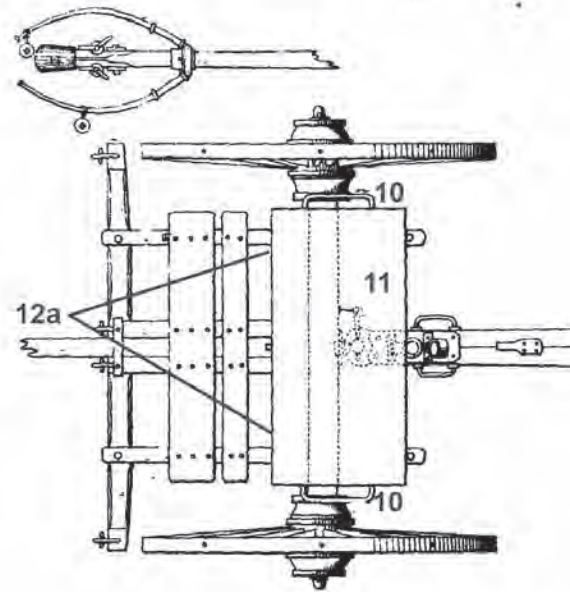
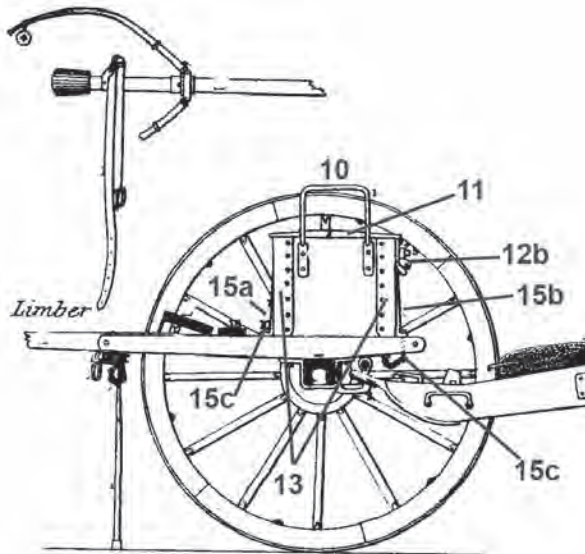

PART III - INSPECTION AND MAINTENANCE

INSPECTIONS

Frequency of Inspections

The piece should be inspected before demonstrations and after the final cleaning on that particular day. Ordnance in storage should be periodically checked.

Problems to Encountered During Inspections

Overall poor cleaning: If the piece is not cleaned immediately after use, the residue will harden in the bore, particularly in small voids or pits. This is very dangerous, as, in subsequent firings, this residue can retain a spark or smolder and ignite the cartridge breaks during ramming.

Overall poor maintenance: Be especially aware of cracks and checks on the cheeks and trail of the carriage since these areas receive the shock of recoil.

The wheels are the most critical and important part of the carriage. They should be tight and roll freely and straight. Spokes should give a “ring” when tapped with a wooden or leather mallet. Flat sounds indicate the presence of rot. Spokes that jiggle or move when grasped indicate shrinkage of the wood and the manufacturer should be notified for re-tightening or replacement. The wheels should be rotated frequently to prevent rot of the felloes, especially if the piece is left on the field for appreciable amounts of time. Any wheel that has to be kept wet in order to be tight is unsound, and should be repaired or replaced.

Rot and insect infestation can be detected by looking for blisters in the paint, a softness of the wood, tiny holes bored into the paint and evidence of fungus. Areas where water can be harbored, such as between the spokes on the wheels, the prolong hooks, the lunette and the felloes of the wheels if stored in soft ground or grass especially susceptible to rot.

Wooden implements should be free from serious cracks and splinters. Sponges should be inspected closely for soundness.

The chest should be properly made, having non-sparking materials on the inside. All nails are countersunk and the heads puttied over.

The lid should fit snugly and be provided with a lock. The chest is to be kept locked when not serving ammunition.

The chest is clean and free of spilled powder. All equipment and ammunition are neatly and securely stored in the chest.

Enlarged vent:

Bore and vent measurements are taken annually and recorded in the Gun Book. Vents were originally .2" in diameter. A vent in excess of .25" in diameter should not be used as this may cause misfires. On reproduction guns, an extra vent piece should be purchased with the gun.

Condition of the bore:

Injuries to bronze guns is minimal, except for the bending of the trunnions after long service or heavy charges. Internal injuries are caused by the action of the firing of the gun.

The lodgement of the shot is a compression of the metal on the lower side of the bore, at the seat of the shot, caused by the pressure of the gas in escaping over the top of the shot. There is a corresponding burr in front of the lodgement, and the motion thereby given to the shot caused it to strike alternately on the top and bottom of the bore, producing other enlargements, generally three in number. Scratches in the bore are caused by fragments of a broken shot or the roughness of an imperfect one.

The entrance of the vent should be checked during inspections for corrosion. The bottom of the bore under the vent should be checked for pits caused by the priming wire striking the bottom of the bore during drill.

The breech face should be checked during inspections to detect any deformities during manufacture caused by boring tools, or scarring caused by excessive use of the worm.

Iron guns will display the above defects in a less degree than bronze, except for corrosion of the metal. The principle cause

of injury in iron guns is from the rusting of the metal. Iron guns that have liners cast in place will have a slight narrowing of the bore at the cascable. Extra care should be taken if firing projectiles to ensure adequate windage as a shot may be fused-welded in the bore.

The following checklist should be used when inspecting individual pieces. Newly purchased ordnance should be inspected using this checklist prior to placing into service.

Recommended tools for inspections include:

- Rawhide mallet
- Craft knife ("X-Acto") knife, or a pocket knife with a thin blade
- Pocket Mirror or "Mini-Mag" light
- Vent gauge



Historic Weapons Program



Artillery Inspection Checklist

Park: _____ **Weapon:** _____ **S.N./Prop.#** _____

The Gun:

- The gun is clean and free of rust and corrosion.
- No sign of external damage or strain (dents, cracks, etc.).
- Inside of bore is smooth or relative smooth.
- No internal signs of damage (bulges, lodgments, pits, etc.).
- No sign of corrosion damage at breach of the bore.
- On iron guns with liners, the liner is secure.
- The vent is clear and of acceptable size (not to exceed .25").
- No signs of cracks or bending around the trunnions.
- No signs of weakness at the chaplets on bronze tubes.

The Carriage:

- Wheels are tight and free of rot or insect infestation.
- Body of the carriage is free of rot or insect infestation.
- No parts are missing, cracked, bent or broken.
- Wheels move freely.
- Elevating mechanism works smoothly and properly.
- None of the ironwork is loose.
- Tube rotates freely on its trunnions.

Equipment:

- All necessary equipment is present.
- Sponge is in good condition and fitted to the bore.
- Rammer head is secure and free of cracks.
- Prongs of the worm are sharp and not bent.
- Smaller items in good condition (linstock, thumbstall, buckets).
- Leather gauntlets in good condition (not hard, dry, or torn).
- Limber box and haversack is clean and free of spilled powder.
- The gun book is kept up to date.

- Trunnion caps fit snugly and are properly keyed.
- Lids of limber chests and/or side boxes fit securely.
- Wood generally free of serious checking or splintering.
- Wheel hub does not gouge the end of the axle tree.
- Linch pin is not digging into wheel hub.

This Firearm: _____

Passed: _____

Failed: _____

Comments: _____

INSPECTOR: _____

DATE: _____

MAINTENANCE

Following the Day's Demonstrations

The cannon should be cleaned with mild soap (i.e. "Ivory") and fresh water after the conclusion of the day's demonstration. Use a sponge or brush to scrub the bore. The elevation screw should be turned up fully to allow excess water to run out the bore. Excess water should be wiped off the carriage. Fouling should be removed from the vent field with water and a toothbrush. The bore on iron cannons should be lightly oiled after being completely dried with a rag to prevent rust.

For better cleaning, you can use a pressure washer or the hose from a coin-operated car wash to clean the bore.

The sponge should be washed in soapy water after the day's demonstration. It should be spun to prevent the nap from matting. The sponge should be allowed to dry in a standing position.

Since powder fouling deteriorates the fibers, sponges should be inspected frequently and replaced as necessary. In no case should a sponge be allowed to deteriorate to the point where there are loose threads and rotting of the material.

The worm should be cleaned thoroughly of fouling and dried.

The sponge bucket should be rinsed and turned over to dry.

The priming wire should be wiped clean of fouling.

The ammunition chest is checked to ensure it is clean of any spilled powder.

The day's entry is made in the Gun Book.

The piece should be kept limbered when on the field, the limber wheels chocked, the lock chain secured and the ammunition chest padlocked. If a piece must be kept in the field, then it should be covered with a tarpaulin to protect it from rain and dew.

Long Term Maintenance

For long-term maintenance and preservation, the piece should not be left exposed to the weather. The piece should be kept in an unheated building or other similar structure. Carriages left exposed to the effects of the elements will deteriorate rapidly.

The Gun:

Notations on bore and vent diameters are recorded annually in the Gun Book.

Hardened fouling in the bore can be removed by use of a stove pipe brush of proper diameter attached to a staff. Fouling can also be removed by use of scrubbing patches.

The vent can be cleaned of fouling with a .177 caliber bore brush with a pistol cleaning rod. The vent should be covered while in storage.

Iron guns in storage should be checked from time to time to see that moisture does not collect in the bore and re-oiled as necessary.

The Carriage:

Some checking of the wood can be expected. Filling of cracks or checks should be done with soft, elastic filler that will allow expansion and contraction of the wood. Hard putty or similar products will sink into the crack and act as a wedge as the wood breathes.

It is recommended that cracks on horizontal surfaces be filled, since they would allow water to soak into the wood, shortening the life of the carriage.

All surfaces (carriage and implements) should be painted (or stained) as needed.

The elevation screw and the axle should be kept lightly lubricated with common ball bearing grease.

Implements and Accoutrements:

Rammer and sponge heads are securely fastened with hardwood dowels, and non sparking metals are used in the construction. During the off-season it is a good idea to soak the sponge head in boiled linseed oil, to minimize deterioration. Paint as necessary.

The sponge bucket should be checked for rust and painted as necessary.

Leather accoutrements should be cleaned with saddle soap to remove dirt. Gloves and gauntlets should be kept clean and flexible with saddle soap. Leather accoutrements should be removed from the ammunition chest prior to long-term storage. Dry leather can be restored with neats foot oil, Lexol or similar leather preservative.

Sponges should be covered when dried.

PART IV - ARTILLERY DRILL

MANUAL OF THE PIECE

The movements and motions for each member of the detachment are derived from Barry, French and Hunt, Instruction for Field Artillery, 1860 (Revised in 1864), which is by detail. In actual service the only commands given by the Gunner are “Load,” “Ready” and “Fire.”

For the purposes of instruction of the detachment, or if desired to show the drill step-by step to the visitors, “Load by detail” may be used. This procedure may not be used when firing blank or live rounds. Although instructive for No. 1 and No. 2 cannoners, this loading procedure can seem disjointed and time consuming for other members of the detachment and should be discontinued as soon as possible to let the detachment experience the normal flow of the drill.

In this procedure, the commands may be given by the Chief of Section, Chief of the Piece or the Gunner. Each member of the detachment performs his duties with the commands, which are: “Load by Detail—LOAD; two, three four: SPONGE, two three four: RAM, two, three; READY; FIRE; CEASE FIRING.”

It is highly recommended that the demonstrators become familiar with the field artillery tactics of their historical period. Several manuals are available, many in reprinted form, and the information contained in them varies little between versions. The demonstrator should become well familiar with Artillery and its Duties, Organization and Equipment of Field Batteries, The School of the Piece, Mechanical Maneuvers, and the Formations of the Battery.

Minimum Number of Demonstrators

The detachment for National Park Service artillery demonstrations shall consist of at least six people, the Gunner and Cannoners No. 1 through No. 5. A separate demonstration interpreter is required to interact with visitors and monitor range safety.

Minimum Time Period Between Firings

Since rapid firing is one of the four principal causes of artillery accidents, it is not permitted in NPS demonstrations. A minimum of ten minutes must pass between firings during demonstrations. This pause also allows for interpretation to take place in between multiple firings.

Required Dress and Safety Equipment

- The demonstrators shall be dressed in all natural fabric period uniforms consistent with the time period being interpreted.
- All demonstrators must wear period uniform coats or jackets when firing.
- It is recommended that items which may encumber the demonstrator, such as sabers, pistol holsters, haversacks, etc. not be worn during the demonstration. Canteens may be worn or placed near the limber. If haversacks are worn, they should be nearly empty with no cups attached to the outside. Spurs should be worn only when a caanoneers is comfortable walking while wearing them.
- Cannoneer Number One wears heavy protective gauntlets, similar to welder's gloves.
- Cannoneer Number Two wears buckskin or light leather gauntlets, similar to "cavalry" gauntlets.
- All demonstrators will wear appropriate hearing protection.

PLACING THE PIECE

This action should take place administratively unless the detachment intends to unlimber the piece prior to firing (see appendix). The piece is taken to the drill ground, unlimbered, and prepared for action; the limber in position behind the piece, and facing towards it; the end of the pole 6 yards from the end of the trail handspike. If arranged in sections, the pieces are 14 yards apart.

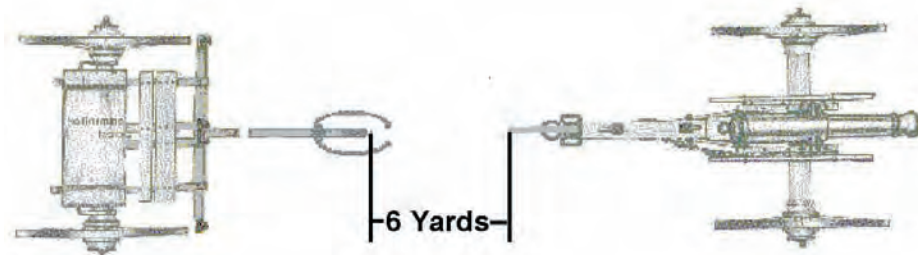

RANGE REQUIREMENTS

- A physical barrier must separate visitors from the demonstration area.
- Limber must be at least 7 yards away from visitors.
- Gun must be at least 12 yards away from visitors.
- No visitors must be forward of the plane of the muzzle face.
- There must be at least 50 yards of clear area down range.

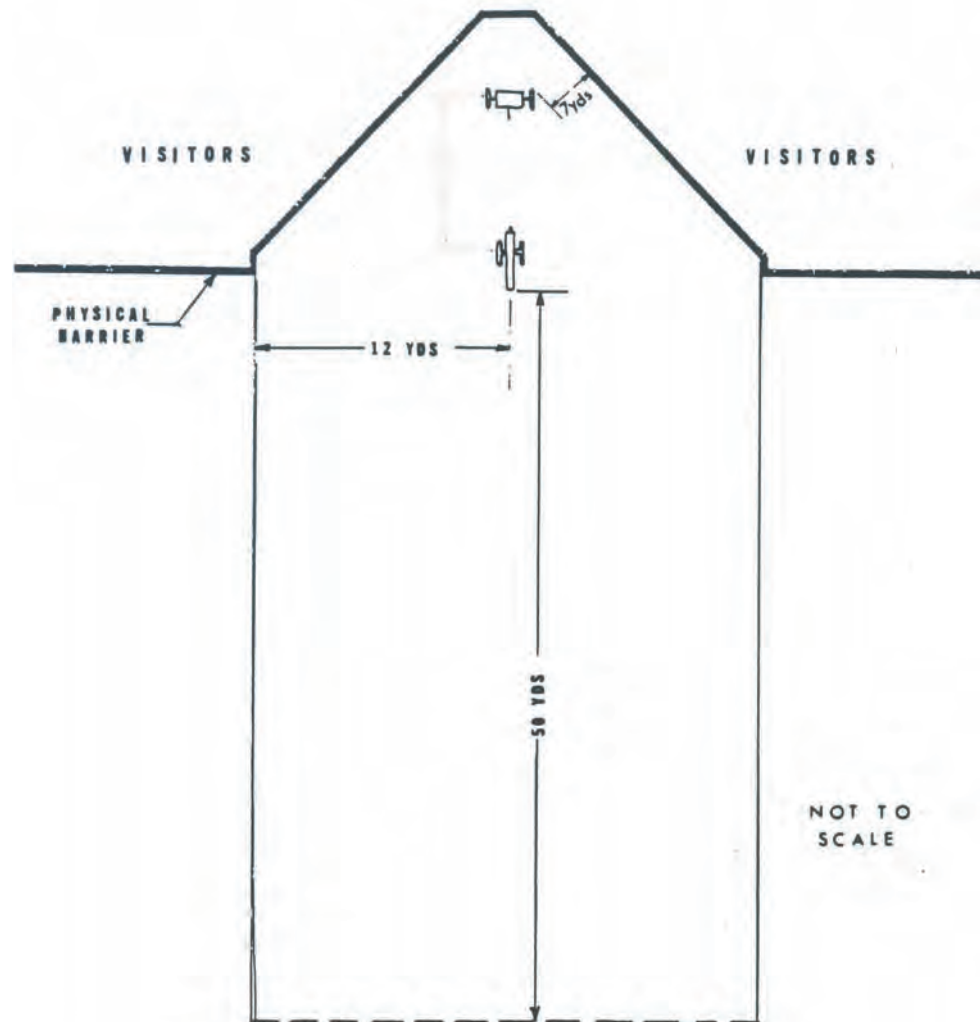

COMMANDS FOR LOADING AND FIRING

In one-gun demonstrations the commands for loading and firing will be given by the Gunner. This procedure is somewhat in variance with the procedure used in actual field service. Since in a battery organization the Gunner would communicate those orders from the Chief of the Piece to his detachment. For commands for firing by battery or by section, see the appendix of this manual.

For the purposes of this manual it is assumed that the Gunner will be giving these orders to the detachment directly. It may be well to consider, however, the use of a Chief of the Piece, or Chief of Section, as the interpreter as required by the National Park Service Historic Weapons Safety Standards. By doing this, the safety requirements will be satisfied, and historical accuracy will be enhanced.

Command	Action
To Your Posts	Directs the detachment to fall into their respective places on the piece.
Commence Firing	When given by a superior or the interpreter, this command gives the Gunner permission to direct his crew to load and fire without further orders.
Load	Gunner's executive command that signals the cannoneers to begin loading the piece.
Ready	Gunner's executive command that begins the process for preparing the piece to fire after the round is loaded.
Fire	The executive command that leads to firing the piece. Only the Gunner gives this command in a one- gun demonstration. This point must be strictly adhered to, so as to prevent Number 4, who is looking away from the piece when in firing position, from prematurely pulling the lanyard.
Cease Firing	At this command the cannoneers will return to their positions at " <i>To your posts.</i> " Since rapid firing is prohibited, "Cease firing" is given after one discharge of the piece.
Stop	<p>This non- military command may be give by anyone who sees an unsafe condition such as a violation of the range area. When "Stop" is called, all cannoneers will immediately stop and maintain their positions with the following exceptions:</p> <ol style="list-style-type: none"> 1. If No.2 has the charge in his hands, he will put it back into the Gunner's Haversack. 2. If No. 1 is in the act of ramming, he will stop, withdraw the rammer and step outside the wheel. 3. If the charge is seated, but the No. 1 is still inside the wheel, he will step outside the wheel. <p>Once safe conditions have been restored, the gunner may restart the drill using the appropriate executive command.</p>

“TO YOUR POSTS”

Gunner: at the end of the trail handspike.

Number 1: about two feet outside the right wheel; with guns, in line with the front part of the wheels; with howitzers, slightly in rear of the muzzle.

Number 2: about two feet outside the left wheel; with guns, in line with the front part of the wheels; with howitzers, slightly in rear of the muzzle.

Number 3: in line with the knob of the cascable, covering Number 1.

Number 4: in line with the knob of the cascable, covering Number 2.

Number 5: five yards in rear of the left wheel.

Number 6: to the rear of the limber at the chest.



Number 7: To the rear of the limber and to the left of Number 6, covering Number 5.

All face to the front.

If the Chief of Piece is present, he is posted opposite the middle of the trail handspike, outside and near the left cannoneers. In actual firing he takes his place on the right or left, where he can best observe the effect of the shot.

SEARCHING THE PIECE

No command for securing or searching the piece can be found in the original manual. This is because the piece is meant to go into action after unlimbering and be secured prior to limbering. An administrative action for ensuring the piece is unloaded and free of obstructions or debris has been added to the NPS drill to enhance safety.

Prior to each demonstration, the gunner will ensure that the following procedure is performed..

The No.3 will step in and cover the vent with the thumbstall. No. 1 or No. 2 will step in and worm the piece to remove any foil residue or other objects from the bore. No. 3 will put the priming wire down the vent to check for obstructions then return to his “To Your Posts” position.

This procedure should be performed prior to each demonstration.

“LOAD, READY, FIRE” – LOADING AND FIRING THE PIECE

The following tables give a brief description of the duties of each cannoneer at each command. Although each member of the detachment is assigned specific duties, the process can only be accomplished safely and effectively when all of the cannoneers work as a team.

The motions described below should like a choreographed dance to the observer. This manual cannot entirely convey the level of cooperation required to produce an efficient drill. Constant practice that leads to a comprehensive knowledge of each position and its relationship to the rest of the detachment is the only way master the duties described below.

Following the detachment tables, are detailed instructions for each member of the detachment based on the original manual as well as illustrations and additional reference tables.

LOAD

Gunner	No. 1	No. 2	No. 3	No. 4	No. 5
Gives the command "LOAD."	Faces left and steps to the muzzle in three steps starting with the right foot.	Faces to the right and steps to the muzzle, facing the rear, in three steps starting with the left foot.	Takes one large sidestep to the left.	Hooks a friction primer to the lanyard hook and awaits the "Ready" command.	Faces about and goes to the limber repeating the gunner's choice of ammunition.
Uses the handspike to point the piece.	Sponges bore.		Covers the vent with the thumbstall on the left thumb.		Opens Gunner's Haversack to allow No. 6 to put the round inside.
Places pendulum hausse on seat and adjusts elevation.	Taps muzzle to signal No. 2 to insert the round.	Takes the round from the Gunner's Haversack when No. 1 taps the muzzle.			Brings the round to No.2 stopping first at the gunner for fused rounds.
		Faces left and places the round in the bore.			Opens the haversack when No. 2 turns towards him.
		Returns to position outside the wheel, facing the gun, using three steps starting with the left foot.			Returns to his "To Your Posts" position as soon as No. 2 takes the round.
	Rams the round after No.2 is outside the wheel.	Watches the No. 1 ram to ensure the round is seated.			
	Returns to position outside the wheel, facing the gun, using three steps starting with the right foot.		Turns clockwise and goes to the handspike after No. 1 has cleared the wheel.		
Uses hand signals to tell No. 3 how to assist in fine pointing.			Points the piece as directed by the gunner.		
Gives "touchdown" sign to signal No. 3 to return to his position.			Returns to "To Your Posts" position when given the "touchdown" sign by the gunner.		
Moves back from the gun and assumes a good observation position.					

READY

Gunner	No. 1	No. 2	No. 3	No. 4	No. 5
Gives the command "READY."	Steps back with the left foot.	Steps back with the right foot.	Takes one large sidestep to the left.	Takes one large sidestep to the right.	Remains in his "To Your Posts" position and watches the downrange area directly in front of the gun for safety issues.
Watches drill and range for safety issues.	Holds the sponge rammer in both hands with the arms hanging loosely (sponge to the left).	Drops his hands to his sides.	Punctures powder charge with the priming wire.		
	Looks downrange and watches the area to the left of the gun for safety issues.	Looks downrange and watches the area to the right of the gun for safety issues.		Places primer in the vent after No. 3 removes the priming wire.	
			Holds down the lanyard along the breech with fingers placed just below the hook	Plays out enough slack to allow No. 3 to hold down the lanyard	
			Maintains eye contact with the No. 4	Maintains eye contact with No. 3	
				Side steps to the left until lanyard is taught	
				Nods visibly to signal No.3 to step out	
			Returns to his "To Your Posts" position when No. 4 nods.		
				Turns head to look away from the gun when No. 3 is outside the wheel.	

FIRE

When the gunner commands "FIRE," the No. 4 pulls the lanyard by shifting his bodyweight to the left and pulling his arm behind his body.

KEY POINTS

Key Points at "LOAD":

- The steps of No. 1 and No. 2 as they approach the muzzle should be taken in concert.
- The duty of No. 3 to cover the vent until the No. 1 has cleared the wheel is the most critical part of his responsibilities during the loading sequence.
- The sequence for placing the round in the bore begins when No. 1 taps the muzzle. No. 2 should not turn to take the round until he hears the tap. No. 5 should not open the haversack until the No. 2 turns to take the round.

Key Points at "READY":

- The Gunner should not give the "Ready" command until he is certain that all members of the detachment are in the correct position and that the range is clear.
- The steps back of No. 1 and No. 2 should be made in concert.
- The side steps to the breech by No. 3 and No. 4 should be made in concert.
- No. 3 must not place his fingers through the priming wire loop nor place his hands or fingers on top of the wire.
- If No. 3 does not feel the round being punctured, he should call "STOP" immediately so the charge can be re-seated.
- Eye contact between No. 3 and No. 4 is critical to ensure that No. 3 sees the nod signal to return to his post.

Key Points at "FIRE":

- The Gunner should not give the "Fire" command until he is certain that all members of the detachment are in the correct position and that the range is clear.
- No. 4 must use his body motion to pull the lanyard. Use of the arm may result in a whipped primer.

When the gun fires, all cannoneers will immediately begin their duties for the "Load" command without further orders from the gunner. The gunner will wait until the No. 1 to insert the sponge before commanding:

“CEASE FIRING”

At the command to “Cease Firing,” all cannoneers but the No. 1 and No. 3 will return to their “To Your Posts” positions.

Position	Duties
No. 1	<ol style="list-style-type: none">1. Continues sponging and removes the remaining foil.2. If no foil comes out with the sponge, he will use the worm to secure the piece.
No. 3	<ol style="list-style-type: none">1. Continues to tend the vent until No. 1 has cleared the wheel;2. Runs the priming wire down the vent to make sure it is clear; and3. Returns to his “To Your Posts” position

INSTRUCTION FOR INDIVIDUAL POSITIONS

The following are more detailed descriptions of the duties of each position. Although these duties may be practiced individually, it is best to train as a detachment so that the cannoneers develop an understanding of how their individual duties mesh with those of the other members of the detachment.

DUTIES OF THE GUNNER

The Gunner:

- Gives all executive commands in action during a one-gun demonstration;
- Is responsible for ensuring that all the numbers perform their duties correctly;
- And helps ensure that range safety is maintained during a demonstration.

1. On receiving the command or signal to commence firing, he gives the command “Load.”

2. He takes hold of the trail hand spike at the end with his right hand and at the center with his left. He places his knee against the handspike near the left hand. He points the piece by using his body against the handspike as a lever to drag the trail left or right.



3. When the gun is pointed, the Gunner moves to the breech and places the hausse on its seat. He leans down to look through the hausse by bending the left knee and keeping the right leg extended to the rear. He adjusts the elevation by turning the elevation screw.



4. When No. 3 goes to the trail handspike, the Gunner will indicate to him the direction by tapping on the trail. He taps on the right side to aim the muzzle to the right and taps on the left to aim the muzzle to the left.



5. As soon as the Gunner is satisfied with the aim, he makes a signal by raising both hands (the “touchdown” sign), so that No. 3 may resume his position at “To your posts.”



6. He then removes the hausse and moves to where he can best observe the detachment and range, gives the command “Ready.”



7. When all cannoneers are in their proper positions and the range is safe, he gives the command “Fire.”

Note: It is important to note that the original manual states that the Gunner remove the hausse, give the command “Ready” then to step out to observe the effect of the shot. For our purposes this is not deemed advisable because, if the Gunner hurries, as there is sometimes a tendency to do, No. 3 will not have sufficient time to return to this position outside the wheel and more importantly, before the priming process begins, the gunner should be sure that the range is clear. To accomplish this end the Gunner will move to a position where he has a good view down range before giving the command “Ready.”

DUTIES OF THE NUMBER 1 and NUMBER 2 (BY DETAIL)

“TO YOUR POSTS”



No. 1	No. 2
<ul style="list-style-type: none">• Stands facing forward opposite the front of the left wheel.• Holds the sponge rammer at about the middle of the staff in his right hand with the staff at a 45- degree angle.	<ul style="list-style-type: none">• Stands facing forward opposite the front of the right wheel.• Hands held at his sides.

“LOAD”



No. 1		No. 2	
1.	Faces to the left.	1.	Faces to the right
2.	Steps obliquely to the right with his right foot, without moving his left, and at the same time brings the sponge smartly to a perpendicular position by drawing his right hand up in line with the elbow, which close to the side.	2.	Steps obliquely to the left with his left foot without moving his right.

“TWO”



No. 1	No. 2
<p>3. He steps obliquely to the left with his left foot, planting it about halfway between the piece and the wheel, and opposite the muzzle.</p> <ul style="list-style-type: none">• While making this step he brings his right hand to his chest placing the sponge staff at a 45 degree angle across the body.	<p>3. He steps obliquely to the right with his right foot, planting it about halfway between the piece and the wheel, and opposite the muzzle.</p>

Note: When stepping in No.1 will insure that the distance he places himself in front of the muzzle will not be so great as to prevent his body from being behind the muzzle when the charge is seated. In most cases, the mid-line of the body will be aligned with the muzzle face.

“THREE”



No. 1	No. 2
<ol style="list-style-type: none">4. He steps up with his right foot and places it about 30 inches apart from the left so he has a comfortably wide stance and his body is aligned parallel to the gun.5. He bends his right knee and brings the sponge to the muzzle face with the staff parallel to the ground.<ul style="list-style-type: none">• As he puts the staff in the proper position, he will slide the right hand as far as possible towards the rammer without releasing it or changing the hand's position.	<ol style="list-style-type: none">4. He steps up with his left foot to the position of attention with his body is aligned parallel to the gun.5. He faces to the right and brings his hands up to his chest.

Note: From this point forward, the No. 1 one's feet should not move until he steps back from the piece. All sponging and ramming motions will be executed by straightening and bending the knees and moving his body weight back and forth.

“FOUR”



No. 1	No. 2
<p>6. While looking at the vent, the No. 1 inserts the sponge-head into the bore.</p> <p>7. He drops his left hand behind his thigh and straightens the right knee while bending over the left. This shifts the body back towards the breech and will slide the sponge to the breech face.</p>	<p>6. Remains in position looking back towards the limber.</p> <p>7. Remains in position looking back towards the limber.</p>

“SPONGE”

No. 1	No. 2
8. He continues to look at the vent and turns the sponge for two full revolutions while holding it firmly against the breech.	8. Remains in position looking back towards the limber.

“TWO”



No. 1	No. 2
9. He draws out the sponge by straightening his left knee, and bending his right and slides the right hand to the middle of the staff. 10. He places the sponge against the muzzle face.	9. Remains in position looking back towards the limber. 10. Remains in position looking back towards the limber.

“THREE”



No. 1	No. 2
<p>11. He turns the staff by turning his right wrist to the right until the rammer is facing the muzzle.</p> <p>12. He holds the staff with the left hand near the rammer while sliding the right hand towards the sponge.</p> <p>13. He gently taps under the swell of the muzzle to signal No. 2 to insert the round.</p> <p>14. Remains in position until No. 1 steps back outside the wheel.</p> <p>15. Remains in position until No. 1 steps back outside the wheel.</p>	<p>11. Remains in position looking back towards the limber.</p> <p>12. Remains in position looking back towards the limber.</p> <p>13. He turns his upper body to the right and takes the round from the haversack that is opened by No. 5 when No. 2 turns.</p> <p>14. He faces to the left and places the round (powder charge to the rear) into the bore.</p> <p>15. He steps back outside the wheel.</p> <ul style="list-style-type: none">• He takes a large step back with the left foot.• He steps slightly back and to the right behind the wheel with his right foot.• He places his left foot so it is even with the front of the wheel.



Note for No. 1: No. 1 should get the right hand as close to the sponge as possible. This will make the ramming process easier.

Note for No. 2: No. 2 must check the round to make sure the powder charge is facing the rear when he inserts into the bore.

“FOUR”



No. 1	No. 2
16. He introduces the rammer- head into the muzzle.	16. Remains in position watching the No. 1's ram to ensure the round is seated.
17. He points the left hand over the gun towards the left trunnion	17. Remains in position watching the No. 1's ram to ensure the round is seated.
18. He turns his head to the right to look down range.	18. Remains in position watching the No. 1's ram to ensure the round is seated.
19. He slides the right hand up the staff so the thumb is almost touching the sponge.	19. Remains in position watching the No. 1's ram to ensure the round is seated.

Notes for No. 1:

- The only time both hands will be on the sponge-rammer while the charge is in the bore is when inserting the end of the rammer.*
- It may be necessary to push the charge into the bore slightly in order to slide the right hand up to the sponge. This is hand position is critical to ensure a proper ramming motion.*

Note for No. 2: It is recommended that a mark be placed on the rammer staff to indicate how much of the staff should be beyond the muzzle when a blank round is fully seated.

“RAM”



No. 1	No. 2
20. He leans his body back by bending the left knee and straightening the right until the round is seated at the breech.	20. Remains in position watching the No. 1's ram to ensure the round is seated.

“TWO”



No. 1	No. 2
21. He straightens his body smartly and jerks the sponge out with his right hand, allowing it to slide through the hand as far as the middle of the staff where he grasps it firmly. 22. He pulls the rammer head out of the bore and brings the rammer staff close to his body and grips it near the rammer head with the left hand.	21. Remains in position looking across the gun. 22. Remains in position looking across the gun.

“THREE”



No. 1	No. 2
<p>23. He steps back outside the wheel.</p> <ul style="list-style-type: none">• He takes a large step back with the right foot.• He then steps back and to the left with the left foot behind the wheel.• He brings his right foot to a position even with the front of the wheel and turns the sponge rammer so it is perpendicular with the sponge up.	<p>23. Remains in position looking across the gun.</p>

“READY”



No. 1	No. 2
<p>24. He steps back, and slightly to the left, with his left foot keeping both knees slightly flexed so as to be standing comfortably.</p> <p>25. He spins the sponge down and to the left and holds the staff with his left hand and lets his arms hang loosely to form an “A.”</p> <p>26. He turns his head to the right and looks downrange and observes the areas to the left of the gun.</p>	<p>24. He steps back, and slightly to the right with his right foot keeping both knees slightly flexed so as to be standing comfortably.</p> <p>25. He drops his hands to his sides.</p> <p>26. He turns his head to the left and looks downrange and observes the area to the right of the gun.</p>

“FIRE”

No. 1	No. 2
<ol style="list-style-type: none"><li data-bbox="485 228 1106 456">1. Once the piece fires, he brings his left foot forward and brings the sponge rammer to a vertical alignment in order to return to his position prior to the “Ready” command.<li data-bbox="485 456 1106 649">2. He begins performing his duties from Step 2 above at the command “Load” when drilling by detail or immediately if the drill is not by detail.	<ol style="list-style-type: none"><li data-bbox="1106 228 1724 375">1. Once the piece fires, he brings his right foot forward order to return to his position prior to the “Ready” command.<li data-bbox="1106 375 1724 649">2. He begins performing his duties from Step 2 above at the command “Load” when drilling by detail or immediately if the drill is not by detail.

DUTIES OF THE NUMBER 3 AND NUMBER 4

“TO YOUR POSTS”



No. 3

- No. 3 stands in line with the knob of the cascable, covering No. 1.
- He holds the priming wire in the right hand between the thumb and forefinger.
- The thumb stall is on his left thumb.
- The tube pouch fastened to the waist on the right side.

No. 4

- No. 4 stands in line with the knob of the cascable, covering No. 2.
- The tube pouch is fastened to his waist.

“LOAD”



No. 3	No. 4
<ol style="list-style-type: none">1. He steps to takes one large side step to the left.2. He wipes the vent field with the thumb stall.3. He places the thumb stall pad over the vent and rests his other fingers down the left side of the reinforce.4. He raises his elbow up to allow the Gunner to aim over his thumb. The right hand is on the tube pouch.5. No. 3 keeps the vent closed until No. 1 has stepped back behind the wheel.6. He then turns in a clockwise motion and moves back to the trail handspike.7. He moves the gun left or right based on the Gunner's hand signals. A tap on the right side of the trail means move the trail slightly to the left. A tap on the left side means move slightly to the left.8. When the gunner makes the “touchdown” sign, No. 3 returns to his “To Your Posts” position.	<ol style="list-style-type: none">1. No. 4 inserts the lanyard hook into the ring of the primer, and stands fast. If possible, the open part of the lanyard hook is up when the primer is inserted in the vent.2. Stands Fast3. Stands Fast4. Stands Fast5. Stands Fast6. Stands Fast7. Stands Fast8. Stands Fast

Note for No. 3: It may be necessary to take more than one step to approach the vent for people with a shorter legs.

Note for No. 4: Most commercially made primers have rings that are aligned vertically making it impossible to point the open part of the lanyard hook up.

“READY”

No. 3	No. 4
<ul style="list-style-type: none">9. He steps to takes one large side step to the left.10. Puts the priming wire down the vent gripping it with the thumb and forefinger to prick the charge.11. Waits for the No. 4 to insert the primer and play out the lanyard.12. Holds down the lanyard with the fingers of the left hand along the side of the breech.13. Makes and maintains eye contact with No. 4.14. Stands fast.15. When the No. 4 nods, returns to his “To Your Posts” position using a large side step.16. Stands fast.	<ul style="list-style-type: none">9. Takes one large side step to the right.10. Waits for the No. 3 to prick the charge.11. Inserts the primer into the vent and plays out about 6 inches of the lanyard for the No. 3 to hold.12. Waits for No. 3 to hold down the lanyard.13. Makes and maintains eye contact with No. 3.14. Side steps to the side and slightly to the rear with the arm help parallel to the ground until the lanyard is taught.15. Makes a pronounced nod to the No. 3.16. Once the No. 3 is clear of the wheel, he turns his head to look away from the gun.

Notes for No. 3:

- At no time will the fingers of the right hand be placed through the ring of the priming wire or the hand placed on top of the ring.

- If the No.3 does not feel resistance from the foil when pricking the, he should call “STOP.” This may indicate the charge is not properly seated, and the gunner may command that it be re-rammed. Do not re-ram a round once fire has been introduced to the bore.

Note for No 4: *Take care when assuming the firing position not to pull the lanyard in such a manner as to prematurely fire the piece.*



9



10



10



11



12



12



13-14



15-16

“FIRE”

No. 4 leans his bodyweight to the left by bending his knees and lets his right arm pass behind his body.

DUTIES OF THE NUMBER 5

“TO YOUR POSTS”

The position of No. 5 is covering the left wheel, 5 yards in rear of it. The haversack is worn, hung from the left shoulder to the right side.



“LOAD”

1. At the command “Load,” No. 5 walks to the ammunition chest,.
2. Opens the haversack to allow No. 6 to place the round in the haversack so that the cartridge (powder) will be to the front.
3. Takes the round to No. 2, stopping at the Gunner for fused rounds (See Below).
4. When No. 2 turns to take the round, holds open the pouch, and No. 2 takes out the round with both hands.
5. Returns to his “To Your Posts” position and watches downrange area directly in front of the gun for safety issues until the gun fires.



Notes:

- For rounds with extenders or heavy foil in front, it is critical that the No. 5 ensure that the round is placed in the haversack properly so that the powder will end up below the vent when loaded. The No.2, and sometimes the gunner, should also check the round placement before it is inserted into the gun.
- In firing shells or spherical case, the No. 5 shows the fuse to the Gunner before delivering the charge to No. 2. The No.5 will stop near the gunner's aiming position and shout "Gunner, case (or shell) ___ seconds." When the gunner turns, the No. 5 opens the haversack allowing the gunner to inspect the round. The gunner may send the round forward by saying, "yes."
- Should an emergency occur before No. 2 inserts the charge, No. 5 will go to the piece and have the charged replaced in the haversack, until the emergency is corrected or, if the firing demonstration is cancelled, he immediately returns the charge to the ammunition chest.

DUTIES OF THE NUMBER 6

No. 6 is stationed in the rear of the ammunition chest, and issues the ammunition, making sure that the round is placed with the charge (powder) facing forward in the gunner's haversack. Historically he is provided with a fuze gouge and prepares the shell and spherical case shot according to the distance or time ordered, before delivering it to No. 5.



DUTIES OF THE NUMBER 7

No. 7 is in rear of and near the left limber wheel. It is his duty to assist No. 6 in the preparation of ammunition and servicing of it to No. 5. He is provided with a haversack. In the NPS drill, the No. 7 mainly acts as an additional observer for safety issues.

“CEASE FIRING”

- When one round has been fired, the gunner will command “Cease Firing,” taking care not to do so until the No. 1 has inserted the sponge. Once the cease fire command has been given, all cannoneers will return to their “To Your Posts” positions except for the No. 1 and No. 3.
- No. 1 will finish the sponging process while No. 3 tends the vent. If the leftover foil does not come out on the sponge, the No. 1 or No.2 will use the worm to remove the foil.
- When finished sponging, the No. 1 will return to his “To Your Posts” position.
- Once the No. 1 clears the wheel, the No. 3 will run the priming wire down the vent to make sure there are no obstructions, and then he will return to his “To Your Posts” position.

“SECURE THE PIECE”

No command for “Securing the Piece” can be found in the original manual, however, this procedure may be of benefit as part of the interpretive firing demonstration.

- The No. 1 will place the sponge rammer on its hook and slide the rammer down to the stop.
- The No. 3 will secure the sponge rammer with the chain and key.
- The gunner will remove the trail handspike from the pointing rings and hand it to the No. 4.
- No. 4 will secure the trail handspike on the left cheek using the ring and hook.
- Local protocols may include replacing the vent cover and tompion.

DIMINISHED NUMBERS

These positions, enumerated above, comprise the full gun detachment for National Park Service, 19th Century Field Artillery demonstrations. **A minimum of six (6) cannoneers are required to fire a cannon during a National Park Service demonstration.**

The period manuals contain a chart detailing the additional duties of cannoneers when less than eight men are present. The National Park Service drill does not follow this chart. When only six cannoneers are present, the No. 5 performs the duties of the No. 6 in addition to his own duties.

FIRING WITH A LINSTOCK AND QUILL PRIMERS

For those parks whose interpretive emphasis is the pre-Civil War era, or the friction primers are not igniting properly, the piece can be fired with a linstock and quill primer.

The duties of the detachment are the same with the exception of No. 3 and No. 4.

No. 3: At the command “Ready,” No. 3 steps to the piece, pricks the cartridge with the priming wire and inserts the primer. He then returns to this post.

No. 4: stands in line with the knob of the cascable, covering No. 2., at the command “Load,” he steps in and takes the linstock from its socket, steps back again, and plants it in his rear, facing to his right and stepping off with this right foot for that purpose. He lights the slowmatch, then he steps back to his place outside the wheel; holding the linstock stock firmly in the right hand, finger nails to the front, the linstock stock touching the wheel and the slowmatch inside of it.

At the command “Fire,” he raises his hand slowly, clear of the wheel, turning the back of the hand to the front, brings the linstock rather in front of the vent and fires. As soon as the gun is fired he lowers the linstock slowly.

Note: The manufacture of slowmatch can be found in the National Park Service 18th Century Artillery Manual. The use of port-fires is prohibited.

“CHANGE POSTS, MARCH”

In order to instruct the men in all duties at the piece, the instructor causes them to change posts. For this purpose he commands:

1. Change posts.
2. MARCH.

At the command Change posts, the men on the right of the piece face to the rear; those who have equipments lay them down; No. 1 resting the sponge head on the nave of the wheel. At the command MARCH, each man takes the place and equipment of the man in his front (6 man detachment).

No. 1 takes the place of No. 3.

No. 3 “ “ of No. 6.

No. 6 “ “ of No. 7.

No. 7 “ “ of No. 5.

No. 5 “ “ of No. 4.

No. 4 “ “ of No. 2.

No. 2 “ “ of No. 1.

The gunner changes with one of the numbers by special directions of the instructor.

PART V - MISFIRE PROCEDURES

Each park shall develop a written Misfire Plan to address the actions necessary to render the piece safe in the event of a Level I or Level II misfire. The plan must include directions on where and how unfired rounds will be disposed.

TYPES OF MISFIRES

A “Level I Misfire” is defined as a misfire that can be cleared at the demonstration area and the demonstration can continue.

A “Level II Misfire” is a misfire that cannot be cleared at the demonstration area without disrupting the demonstration. Specialized equipment is needed to make the piece safe.

CAUSES OF MISFIRES

Some Causes for Level I Misfires:

- The primer failed to ignite, or incomplete ignition.
- The primer was bent or flipped out of the vent due to improper pulling of the lanyard.

Some Causes for Level II Misfires:

- The cartridge was inserted with the extender end first.
- The cartridge tumbled in the bore so that the fire from the primer will not strike the powder charge.
- The cartridge was not seated fully. Once fire has been introduced to the bore, do not re-ram the charge!
- There is excessive foil on the base of the cartridge so that neither the priming wire nor the fire from the primer will strike the powder charge.
- There is an obstruction in the vent, such as the remains of a primer which separated when last fired.

LEVEL I MISFIRES

The duties of the detachment are described below:

Demonstration Interpreter: The interpreter will explain the procedure to the audience and be alert for possible range violations.

Gunner: In the case of a misfire, the Gunner immediately gives the command “Do not advance, the primer has failed.”

Except in those cases where the primer simply slips out of the vent, or the lanyard hook slips from the loop of the primer, the **minimum waiting time is 30 seconds** before attempting to reprime the piece. When a misfire occurs, the judgment, experience and coolness of the Gunner is essential. In some cases, such as smoke coming from the vent, it may be prudent to wait more than 30 seconds, but in no case (except the two noted above) shall the waiting time be less than 30 seconds.

Note: In the event of a smoking vent, it is recommended that the 30-second count not begin until no smoke is observed coming from the vent.

The Gunner will be alert during the repriming that all members of the detachment perform their duties safely and correctly.

All canonneers not mentioned in the drill table below, will remain in their “Ready” positions until the Gunner determines that sufficient time has elapsed and gives the command:

“REPRIME THE PIECE”

Note: Before performing the following procedures, the No. 2 should remove any items that may encumber him or make contact with the gun or carriage such as his canteen and/or haversack.



No. 2	No. 3	No. 4
Rises from the “Ready” position and steps with the left foot first to position near the axle tree.	Steps up to a position even with the axle, facing the gun.	Steps up to a position even with the axle, facing the gun.



No. 2	No. 3	No. 4
Reaches back with his left hand and removes the failed primer by grasping it between the index and middle fingers.	Stands Fast	Hooks the lanyard to a friction primer.
Drops the failed primer straight down to the ground.	Stands Fast	Stands Fast



No. 2	No. 3	No. 4
Takes the priming wire from No. 3 over the top of the wheel.	Hands No. 2 the priming wire over the top of the wheel.	Stands Fast
Drops the priming wire into the vent using the left hand.	Stands Fast	Stands Fast
Grasps the shaft between the thumb and forefinger and re-punctures the	Stands Fast	Stands Fast



No. 2	No. 3	No. 4
Takes primer hooked to lanyard from No. 4 over the top of the wheel.	Steps back to "To Your Posts" position.	Gives No.2 the new primer hooked to the lanyard over the top of the wheel.



No. 2	No. 3	No. 4
Grasps primer wire between the index and middle fingers of the left and places it in the vent.	Stands Fast	Steps back to "To Your Posts" position letting the lanyard slide down the back of the wheel.



No. 2	No. 3	No. 4
Holds down the lanyard with fingers of the left hand along the breech maintaining eye contact with No.4	Stands Fast	Side steps away from the gun maintaining eye contact with No. 2.
	Stands Fast	Nods to No.2.



No. 2	No. 3	No. 4
Takes hand off the lanyard, steps back outside the wheel, and assumes "Ready" position.	Stands Fast	Stands Fast
Calls out "Ready."	Stands Fast	When No. 2 says "Ready," turns head and looks away from the gun.

The repriming procedure may be tried twice. Once three primers, including the initial demonstration primer, have been expended, the piece should be unloaded using Level II misfire procedures.

If the primers are faulty (not igniting), an attempt can be made to fire the piece with slow match and quill primers. This procedure is outlined below:

No. 2 steps inside the wheel and repricks the charge as before. No. 4 goes to the ammunition chest and obtains a quill primer, returns to the piece and hands it to No. 2, who inserts it into the vent, then steps back outside the wheel.

While the piece is being reprimed, No. 5 lights the slow match, and brings it up to No. 4 as soon as No. 4 has stepped back to his post. On the command "Fire," from the Gunner, No. 4 takes the linstock in the right hand from No. 5 and moves it in a high arc until the glowing end touches the powder on the quill, firing the piece.

LEVEL II MISFIRES

When the piece has failed to fire after three primers have been expended, and the primers are igniting properly, then it is evident that there is a serious problem with the cartridge. In most cases, the cartridge was inserted backwards or the cartridge tumbled in the bore. In these circumstances, the piece will have to be unloaded through the muzzle.

Unloading a piece through the muzzle is a hazardous and delicate procedure. Do not attempt to unload through the muzzle until all evidence of smoke from the muzzle and vent has ceased. Every effort must be made to move as carefully and coolly as possible. Distractions such as visitor kibitzing or razzing must be eliminated by park personnel. It is best to explain the nature of the situation to the visitors and move them away from the demonstration area.

This procedure is administrative and does not have to be performed using a set drill. It is recommended that two experienced people perform the following procedures. The bulk of the detachment should be used to secure the demonstration area and range.

Equipment

The following equipment will be necessary to safely unload the piece from the muzzle.

- No. 1 and No. 2 Gauntlets
- Priming Wire
- Water Supply
- Bucket(s)
- Two (2) 60 cc veterinary syringes
- Worm*
- CO2 Fire Extinguisher with Vent Adapter*
- Face Shield*
- Sponge Bucket

*The need for this item will be determined by the method used to unload the piece.

Procedure

After waiting at least ten (10) minutes. Two experienced cannoneers will perform the following procedure to unload the piece from the muzzle.

1. One person will step into the No. 2 position for a Level I misfire while the other will bring a bucket of water and the syringes to the Level I misfire position of the No. 4.
2. The person inside the wheels will take a full syringe, passed over the top of the wheel and inject the water into the vent. He will repeat the process two more times.
3. The person inside the wheel will insert the priming wire into the vent and re-prick the charge.
4. The person inside the wheel will reach back and gently turn the elevating screw until the muzzle is fully elevated.
5. The person inside the wheel will continue injecting water into the vent until it overflows. When this happens, he will leave his position in the same manner as does No. 2 during a Level I misfire.



When Using a CO2 Fire Extinguisher:

- 6 One person will put on the No. 1 gauntlets and face shield and take the fire extinguisher to the rear of the piece.
- 7 Holding the hose adapter in his strong hand and the cylinder release lever in his weak hand, No. 1 presses the adapter into the vent. Holding the adapter firmly against the breech, he gives a quick blast of CO2, ejecting the cartridge.
- 8 The cartridge is placed in the sponge bucket and broken up to dissolve the powder.
- 9 The fouled water is disposed of as prescribed by the written misfire plan and the sponge bucket is re-filled.
- 10 Depress the muzzle and allow excess water to drain from the bore.



When Using the Worm:

6. Fill the entire bore with water using buckets or a hose.
7. One person, wearing the No. 1 gauntlets will use the worm to remove the round.
8. The cartridge is placed in the sponge bucket and broken up to dissolve the powder.
9. The fouled water is disposed of as prescribed by the written misfire plan and the sponge bucket is re-filled.
10. Depress the muzzle and allow excess water to drain from the bore.

PART VI - ARTILLERY LABORATORY

SPONGES

A sponge should be replaced when it: a) does not fit the bore, or b) is frayed and worn.

Materials Needed:

- Vegetable-tanned saddle shearling (fleece)
- Leather for making washers
- Copper or brass nails/tacks, 3/4 inch
- Hammer
- Waxed thread
- Glover's needle, or awl and saddler's needles
- Sponge pattern
- Pen
- Heavy duty scissors

1. Remove the old sponge from the sponge-head. Inspect the sponge head and repair if necessary. It is recommended that you soak the sponge head overnight in linseed oil and allow it to dry before replacing the sponge.
2. Lay the sponge and end patterns on the flesh side of the shearling. Trace the patterns with a pen, making one side and two end pieces. Trace out a washer on a piece of leather using a pattern or an old washer.
3. Cut out the pieces of shearling and leather with heavy-duty scissors.



4. Sew the side seam of the sponge body using an overhand stitch. An awl with saddler's needles or glover's needle may be used. The body will form a cylinder with the fleece inside.

5. Sew the end onto the sponge body.

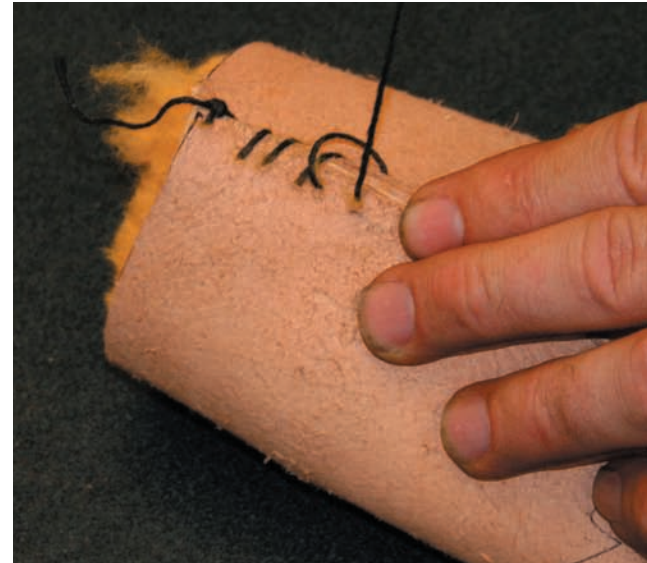
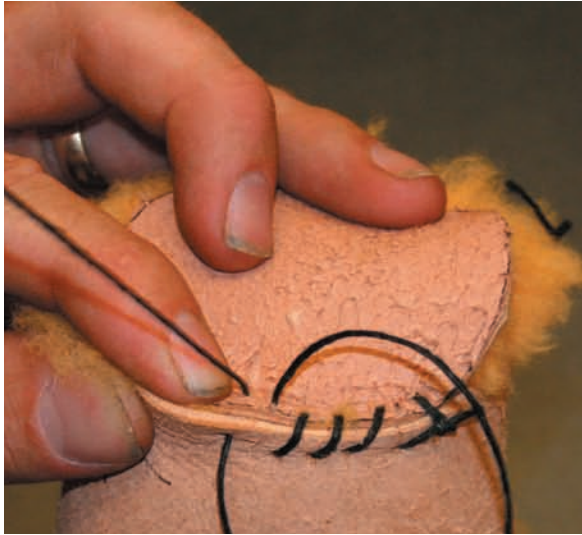

6. Turn the sponge inside out. A large wooden dowel or the handle of a small hammer may be used to help turn the sponge inside out.

7. Place the second shearling end piece on the end of the sponge-head. Slip the sponge over the sponge-head and pull so the sponge fits snugly to the head.



8. Trim excess fleece around the opening so that the sponge can fit snugly around the staff.
9. Slip a leather washer with pre-punched holes around the staff. Drive the nails through the washer holes, through the shearling and into the sponge-head. Also drive one nail into the end of the sponge head.
10. Test the new sponge for proper fit. Trim if necessary.

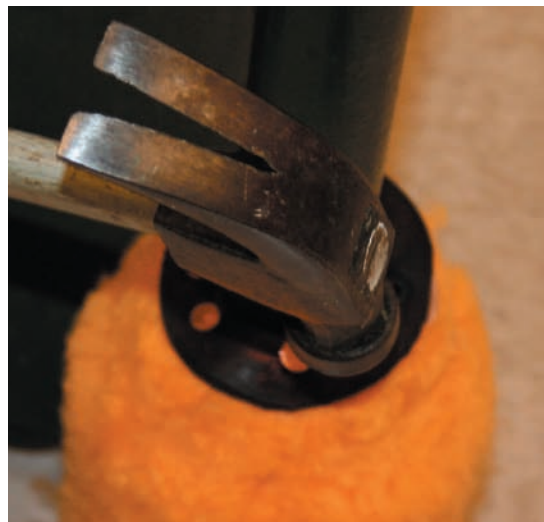

BLANK CARTRIDGES

A cartridge must be long enough to prevent tumbling in the bore, must not allow powder to sift out of the aluminum foil container, and must clearly indicate the end to be inserted first into the bore of the cannon.

The Table of Maximum Loads must be consulted for correct powder charges.

Materials Needed:

- Heavy duty aluminum foil
- Former for caliber of the cannon (tapered to be 1/2 inch smaller than the bore at the large end)
- Damped peat moss or vermiculite
- Powder measure

1. Wrap the foil twice around the former leaving enough foil beyond the end of the former to fold over the bottom.



2. Fold down the foil on the bottom end. Compress the foil completely.

3. Remove the wooden mold.



4. If you intend to use an extender, make a second, shorter aluminum container as before.
5. Fill the second container with peat moss (or vermiculite), leaving several inches of foil at the top.
6. Twist the top of the peat moss cylinder closed.
7. Place measured powder into the long foil cylinder.



8. Place the peat moss extender on top of the powder.

9. Twist the top of the long cylinder closed.

10. The completed cartridge should have the powder end clearly identified to prevent inserting the wrong end into the bore of the cannon. This can be done by twisting a portion of the foil to form a teat when closing the aluminum container, or by marking the powder end with a felt pen.



Note: If your rammer head has a cupped end, use care when forming a foil teat on blank rounds. The foil can be caught by the rammer and be pulled all or partially forward when removing the sponge rammer. This can lead to a misfire. Since the cupped rammer end was designed to accommodate fused rounds, which are not used in demonstrations it is recommended that parks use flat rammers or fill in the cups with wood putty.

FRICTION PRIMERS

Only commercially-available friction primers will be used in National Park Service historic weapons firing demonstrations. Recommended sources will be provided at training sessions.

SLOW MATCH AND QUILL PRIMERS

If slow match and quill primers are to be used, they should be purchased or manufactured according to the procedures contained in the 18th Century Artillery Manual.

**National Park Service
Tables of Maximum Loads for Artillery**

18th Century

Weapon Type	Caliber	Maximum Blank Charge
Swivel Gun	2- pounder	4 ounces Cg or Fg
“Grasshopper” Bronze	3- pounder	6 ounces Cg or Fg
British Light Gun	6- pounder	12 ounces Cg or Fg
British Field Howitzer	5.8 inch	10 ounces Cg or Fg
Iron Gun	3- pounder	6 ounces Cg or Fg
Iron Gun	4- pounder	8 ounces Cg or Fg
Iron Gun	6- pounder	10 ounces Cg or Fg
Iron Gun	12- pounder	20 ounces Cg or Fg
Howitzer	8 inch	36 ounces Cg or Fg
Howitzer	8.76 inch	16 ounces Cg or Fg
Iron Gun (Armstrong)	9- pounder	16 ounces Cg or Fg
Iron Gun (Armstrong)	18- pounder	32 ounces Cg or Fg
Iron Gun (Armstrong)	24- pounder	36 ounces Cg or Fg

19th Century

Weapon Type	Caliber	Maximum Blank Charge
M1841 Gun	6- Pounder	10 ounces Cg or Fg
M1841 Field Howitzer	12- pounder	10 ounces Cg or Fg
M1841 Mountain Howitzer	12- pounder	8 ounces Cg or Fg
M1857 Gun- Howitzer (Napoleon)	12- Pounder	20 ounces Cg or Fg
Parrott Rifle	2.9 or 3 inch	10 ounces Cg or Fg
Ordnance Rifle	3 inch	10 ounces Cg or Fg
Lyle Line- Throwing Gun		1.5 ounces Cg or Fg

Note: Maximum blank charges for weapons not identified on this chart will not exceed 50% of the service charge for solid shot. For those weapons for which a service charge is unknown, the maximum blank load will not exceed 2.5 ounces of Fg powder for every 1 inch of bore diameter.

PART VII - ARTILLERY DEMONSTRATION CRITIQUE

NATIONAL PARK SERVICE ARTILLERY DEMONSTRATION CHECKLIST

Before

- () The gun, limber and implements have been inspected using the Artillery Inspection Checklist.
- () Ammunition is properly prepared, with only enough for one days demonstrations.
- () All implements are in their correct place on the piece (not on the ground).
- () Misfire equipment in place at the firing position.
- () Required number of demonstration personnel are present to safely fire the piece.
- () Limber placement is at least seven yards distance from visitors barricade.
- () Cannon placement is at least twelve yards distance from the visitors barricade and muzzle is forward of all visitors.
- () Visitors have a good field of vision of the demonstration.
- () The interpreter has a clear view of all the visitors and downrange area.
- () The carriage is free to recoil if necessary so it won't buck or break carriage.
- () There is a fixed barricade between the visitors and the demonstration area.
- () The wind conditions are not too strong for a safe demonstration.
- () Conditions are not too dry as to risk a range fire from the muzzle blast.
- () First Aid kit is available.
- () Emergency communications are available.

- () There are no open fires nearby (campfires, brush clearing, etc.).
- () Final review of misfire drill and accident procedures.

During

- () The crew is following the approved manual with each person is in their correct position during each portion of the drill.
- () The sponge is adequately damp, but not soaking wet.
- () Cannoneer # 1 and Cannoneer # 2 (the two cannoneers who service the muzzle of the piece) are wearing gauntlets.
- () Gauntlets are not so stiff or heavy as to cause fumbling or other difficulty.
- () When quill primers are used: linstock and lantern are handled safely.
- () The sponge head is not allowed to contact the ground at any time during the demonstration (to prevent grass, sand etc. from sticking to it).
- () If there is a misfire, is it handled correctly.

After

- () After firing, the piece was cleared of all cartridge material, washed and dried.
- () All weapons, explosives and accessory pieces are accounted for.
- () The field piece and limber are secured and stored properly.
- () The demonstration area is inspected carefully for smoldering residue.
- () Sponge head is thoroughly rinsed and dried.
- () All remaining explosives are returned to storage facility.

Demonstration Supervisor: _____ Date: _____

PART VIII - ARTILLERY COMPETENCY EXAM

Rating Sheet – Proficiency in Artillery Drill

Name _____

Date _____

Gunner

- ___ To Your Posts (Stands at the end of the trail handspike)
- ___ Gives all command clearly and in the proper order
- ___ Sets himself in a good observation position before issuing the “Ready” command
- ___ Waits to give the “Cease Firing” command until the sponge has been inserted
- ___ Demonstrates ability to deal with safety issues as they arise (including misfires)
- ___ Demonstrates full competence in all other positions

- ___ Full Competence ___ Approaching Full Competence
- ___ Failed

Comments:

Cannoneer #1

- ___ To Your Posts (even with front of wheel, facing forward, sponge rammer at 45 degree angle)
- ___ Load (uses proper footwork, proper positioning at the muzzle)
- ___ Sponge (Sponge reaches breach, eyes on the vent)
- ___ Ram (uses 1 hand, thumb open, right refused, left hand properly pointed, eyes downrange)
- ___ Ready (Steps back with left foot and drops sponge to the left, eyes downrange)
- ___ Fire (Begins “Load” cycle immediately after gun fires)
- ___ Cease Firing (Finishes sponging and returns to “To Your Posts” position)

Misfire

- ___ Remains in Ready position, eyes down range

- ___ Full Competence ___ Approaching Full Competence
- ___ Failed

Comments:

Cannoneer # 2

- ___ To your post (even with front of wheel, facing forward)
- ___ Load (uses proper footwork, faces the rear, hand cupped at chest)
- ___ Places powder end of the round in the muzzle (No hands or fingers in the muzzle)
- ___ Leaves muzzle immediately after inserting round
- ___ Ready (Steps back with right foot, hands to sides, eyes down range)
- ___ Fire (Begins “Load” cycle immediately after gun fires)
- ___ Cease Firing (Returns to “To Your Posts” position)

Misfire

- ___ Waits for command to re-prime
- ___ Re-prime (keeps back to muzzle, does not touch wheel)
- ___ Extracts primer with the left hand palm up then drops it to the ground
- ___ Takes priming wire from No. 3 over the top of the wheel
- ___ Drops priming wire into vent then pushes down to re-pierce the charge
- ___ Properly takes new primer from #4
- ___ Properly re-replaces new primer & holds lanyard
- ___ Maintains eye contact with #4
- ___ Properly returns to position of Ready
- ___ Commands “Ready”

___ Full Competence ___ Approaching Full Competence
___ Failed

Comments:

Cannoneer # 3

- ___ To Your Posts (in line with Cascabel covering the No. 1)
- ___ Load (proper foot position in movement)
- ___ Seals Vent
- ___ Moves to trail handspike after No. 1 clears the wheel
- ___ Ready (Steps in with No. 4)
- ___ Holds priming wire along the shaft with thumb and forefinger when piercing the charge
- ___ Holds lanyard along breech ring
- ___ Eye contact with #4
- ___ Steps back to “To Your Posts” position when No. 4 nods
- ___ Fire (Steps in to tend the vent immediately after the piece fires)
- ___ Cease Firing (Tends vent until No. 1 clears the wheel then goes to “To Your Posts” position)

Misfire

- ___ Moves to center wheel on the command to re-prime the piece
- ___ Hands priming wire to #2 over the top of the wheel
- ___ Returns to ready position when No. 2 returns the priming wire

___ Full Competence ___ Approaching Full Competence
___ Failed

Comments:

Cannoneer # 4

- ___ To Your Post (in line with cascabel covering the No. 2)
- ___ Load (Hooks lanyard to the primer)
- ___ Ready (Steps in with No. 3)
- ___ Extend Lanyard (eye contact maintained with #3 while extending lanyard)
- ___ Looks away once No. 3 has cleared the wheel
- ___ Fire (hand pulled behind the body)
- ___ Cease Firing (Returns to “To Your Posts” position)

Misfire

- ___ Moves to center wheel on “Re-prime” command
- ___ Passes primer attached to lanyard to #2 over the top of the wheel
- ___ Extends lanyard while maintaining eye contact with #2
- ___ Looks away from the gun after No. 2 has cleared the wheel

- ___ Full Competence ___ Approaching Full Competence
- ___ Failed

Comments;

Cannoneer #5

- ___ To Your Posts
- ___ Load (Repeats gunner’s round choice to No. 6 as he goes back to the limber)
- ___ Opens haversack for No. 6 and checks to make sure the powder charge is facing forward)
- ___ Presents fused rounds to Gunner
- ___ Opens haversack when the No. 2 turns to take the round
- ___ Returns to “To Your Posts” position once round is taken by No. 2

- ___ Full Competence ___ Approaching Full Competence
- ___ Failed

Comments:

APPENDIX A - Manual of the Piece from *Instruction for Field Artillery (1860)*

ARTICLE THIRD.

MANUAL OF THE PIECE.

93. THE instructor should bear in mind that, in every change of numbers at the gun, each recruit has to learn different duties, and to handle different implements from those he was previously engaged with; and these again vary with the several natures of ordnance and machines which an artilleryman must use. It is impossible that such a variety of exercises can be well executed, or even remembered, unless the recruit is made to comprehend the object of the various duties he is called upon to perform. For the purpose of instructing the recruit, each detachment is to be formed in front of the piece, unlimbered, and the different numbers are to be called upon, successively, to perform their respective duties in detail; while the rest of the detachment look on and observe their motions. When it is found difficult to make the recruit sensible of the defect of his position, etc., the instructor will place himself, or another recruit, in the correct position.

94. Nine men, including the gunner, are necessary for the service of a field piece. When, from necessity, the detachment consists of less than nine, the higher numbers are struck out, and additional duties are imposed upon those remaining.

POSTS OF THE CANNONEERS. PIECE UNLIMBERED.

95. The gunner is at the end of the trail handspike; Nos. 1 and 2 are about 2 feet outside the wheels, No. 1 on the right, and No. 2 on the left; with howitzers, rather in rear of the muzzle; with guns, in line with the front part of the wheels; Nos. 3 and 4 are in line with the knob of the cascable, covering Nos. 1 and 2; No. 5 is 5 yards in rear of the left wheel; No. 6 in rear of the limber, and No. 7 on his left, covering No. 5; No. the chief of the caisson, is 4 yards in rear of the limber, and on its left; all face to the front. The chief of the piece is opposite the middle of the trail handspike, outside and near the left cannoneers. In actual firing he takes his place on the right or left, where he can best observe the effect of the shot.

LOADING AND FIRING.

96. The piece is taken at the drill ground, unlimbered, and prepared for action; the limber in position behind the piece, and facing towards it; the end of the pole 6 yards from the end of the trail handspike.

97. Commanding and Pointing. The gunner gives all executive commands in action. He is answerable that all the numbers perform their duties correctly. He communicates the orders which he receives for the kind of ammunition to be fired; sending to No. 6 the time or distance for each round,

when firing shells or spherical case shot. He should, when the firing is slow, see that each faze is properly prepared, and make such corrections as are necessary; for this purpose he, as well as No. 6, should be provided with a fuze-gouge. On receiving the command, or signal to commence firing, he gives the command LOAD; takes hold of the handspike at the end with his right hand, and at the centre with his left; places his left knee against the left hand, bending over it, the right knee being slightly bent; looks over the top of the piece, and gives the direction. He then steps to the breech to give the elevation, which he does by placing the hausse on its seat, taking hold of a handle of the elevating screw, drawing back his right foot, bending over his left knee, and sighting through the slit in the hausse. In the drill of recruits, the gunner should be made to name the elevation and range before stepping up to the breech. When the piece is loaded and pointed, he removes the hausse, gives the command READY, and, stepping clear of the wheel to that side where he can best observe the effect of his shot, gives the command FIRE. As soon as the piece has been fired, he causes it to be run up to its former place if necessary. When the instructor, instead of giving the command COMMENCE FIRING, gives that of LOAD, the gunner repeats it, and performs the same duties as before, except that he does not command FIRE until the firing is ordered to commence. After the command COMMENCE FIRING is given, the action is continued by the gunner, without further commands from the instructor, until the firing is ordered to cease. When the commands are all given by the instructor, as in loading by detail, the gunner performs the same duties, but without repeating the com-

mands.

98. The detachment being formed in front of and facing the piece, the instructor commences by giving the following explanations: The term Cannon embraces all kinds of heavy ordnance, GUNS, HOWITZERS, MORTARS; each is mounted on a carriage; and each field carriage has a limber. The term PIECE is applied to the cannon, and is also used to designate it in union with its carriage, with or without the limber attached. The front of a piece, when limbered, or prepared for moving, is the direction in which the pole points; when unlimbered, or prepared for action, it is the direction in which the gun points; the right and left are in each case determined accordingly. He then repeats the names of the following objects, indicating each of them. The Limber: ammunition chest, lid, handles; POLE: pole-yoke, branches, sliding ring, pole prop, and chain; WHEEL: spokes, felloes, nave, tire; PINTLE-HOOK, and key. The Gun carriage: handspike, pointing rings, elevating screw, handles, sponge hook. The Gun, or Howitzer, giving explanations of the parts: The bore is the interior hollow cylinder which receives the charge. The muzzle is the entrance of the bore. The face is the front plane terminating the piece. . The vent is the hole through which fire is communicated to the charge. The trunnions are the projecting cylinders which support the gun. The instructor then calls No. 1 to the right side of the piece, and indicates the following parts with his hand, after naming them. The SPONGE and RAMMER: staff, sponge, rammer head, ferrules. GUN: bore, muzzle, face, vent. He then commands: To YOUR POSTS.

99. Sponging and Ramming. Until the command LOAD, No. 1 stands square to the front, in line with the front part of the wheels, holding the sponge about the middle of the staff in his right hand, and trailing it at an angle of 45 deg., sponge head up. The instructor commands: By detail-LOAD. 3 pauses; 4 motions. At this command No. 1 faces to the left, steps obliquely to the right with his right foot, without moving his left, and at the same time brings the sponge smartly to a perpendicular position by drawing his right hand up in line with the elbow. The sponge is grasped firmly in the hand, and the rammer head kept just over the right toe, the elbow close to the side.

TWO. He steps obliquely to the left with his left foot, planting it about half way between the piece and the wheel, and opposite the muzzle; bringing the sponge at the same time across his body to the left, so that his right hand may be opposite the middle of the body, the sponge staff being inclined at an angle of 45 deg. across the front of it.

THREE. He takes a side step to the right of 30 inches, and bending his right knee, brings the sponge to a horizontal position, extending the hands to the ends of the staff, the sponge head to the left, the back of his right hand up, and that of his left down, the sponge head against the face of the piece. FOUR. He inserts the sponge head, drops his left hand behind his thigh, shoulders square, feet equally turned out, straightens the right knee, and, bending over the left, forces the sponge home. SPONGE. 3 pauses; 4 motions.

100. At this command No. 1 fixes his eye on the vent to see that it is closed, gives two turns to the sponge, taking great care to press it at the same time against the bottom of the bore.

TWO. He draws out the sponge, at the same time straightening his left knee, and bending his right; seizes the staff near the sponge head with his left hand, back of the hand down, and places the sponge against the face of the piece.

THREE. He turns the sponge by bringing his hands together in the middle of the staff, giving it a cant with each hand, throwing the sponge head over, at the same time turning his wrist, which brings the staff horizontal, and extending his hands to the ends of the staff, back of the left up, that of the other down. During the whole time of sponging, No. 1 keeps his eye on the vent. If at any time it is not closed, he will discontinue the manœuvre, and command STOP VENT.

FOUR. He introduces the rammer head into the muzzle, as soon as No. 2 has inserted the charge, and joins his left hand to his right, casting his eyes to the front. RAM. 2 pauses; 3 motions.

101. At this command No. 1 rams home, throwing the weight of his body with the rammer; bending over his left knee, and passing his left arm, with the elbow slightly bent, and back of the hand up, in a horizontal position over the piece, until it points in the direction of the left trunnion; the right shoulder thrown back, and the eyes cast towards the front until

the cartridge is home. Two. He jerks the sponge out with his right hand, allowing it to slide through the hand as far as the middle of the staff, when he grasps it firmly, and seizing it close to the rammer head with the left hand, back of the hand up, places the rammer head against the face of the piece; both knees straight; eyes to his own front. THREE. He then draws the sponge close to his body, and immediately steps back outside the wheel, first with the right, then with the left foot; so that when the right foot is brought to the right hip may be on a line with the front of the wheel. In drawing the right foot to the left, he gives the sponge a cant with his left hand, at the same time quitting it, and brings the sponge to a perpendicular position in the right hand, the rammer head resting on the right toe.

102. Ready. At this command, which is given as soon as the piece is loaded, or the firing about to commence, No. 1 breaks well off to his left with the left foot, bending the left knee, and straightening the right leg, drops the end of the sponge staff into the left hand, back of the hand down, and fixes his eyes on the muzzle. The heels should be parallel to the wheel, the body erect on the haunches, and the sponge and rammer held in both hands in a horizontal position, sponge-head to the left. The piece having been fired, No. 1 rises on his right knee, and returns to his position, as in the third motion of RAM. At the command LOAD, he steps in and performs his duties in the same manner as before.

103. When the loading is not by detail, No. 1 goes through all his duties at the command LOAD, returns to his posi-

tion outside the wheel, as given in the third motion of RAM; breaks off at the command READY, and at the flash of the gun rises, steps in, and performs his duties in the same manner as before. This he continues until the command CEASE FIRING is given, at which command he resumes the position: To your posts. If the sponging has been commenced when the command CEASE FIRING is given, it is completed before No. 1 resumes his post. In sponging and ramming, if the length of the piece requires it, the sponge and rammer are to be pressed home in two motions, No. 1 extending his right hand to the end of the staff, as soon as it reaches the muzzle. In sponging howitzers, No. 1 presses the sponge to the bottom of the chamber, which should be well sponged out. He wipes the bore by rubbing its whole surface, without allowing the sponge to turn in his hands.

REMARKS ON THE DUTIES OF NO. 1.

104. The position of the left foot will not be considered as absolute; it is given as the usual one, and may be modified according to the calibre of the piece, and height of the man. The same remarks will apply to the distance between the feet. They will be placed in such position, and at such distance from each other, as will enable the man to perform his duties with the most ease and steadiness, and at the same time exert his full strength, which will always be required after firing a few rounds, especially when a new sponge is used. One object of joining the left hand to the right, and casting the eyes to the front whilst ramming, is to refuse the right shoulder; and to secure this object, the left hand, when

it passes over the piece, is not carried further back than the direction indicated. This will keep the shoulders in a line parallel with their position, at the commencement of the movement, until the cartridge is set home, and thus guard against fatal results in case of a premature discharge.

105. Loading. The instructor places No. 2 on the left of the piece, repeats the nomenclature as for No. 1, indicates the following named objects, and explains their uses: STRAPPED SHOT: cartridge, ball, sabot; CANISTER SHOT: cartridge, canister; SHELL, or SPHERICAL CASE SHOT: cartridge, case shot, or shell, fuze. He then commands: To YOUR POSTS. Until the command LOAD is given, as for No. 1, No. 2 remains in his position. On this command being given, he faces to his right, and by two oblique steps, corresponding to those of No. 1, the first with the left, the second at the command Two, with the right foot, he places himself near the muzzle of the piece. At the command THREE, he brings up his left foot to the side of the right, and faces to his right, bringing his hands together to receive the ammunition from No. 5; the cartridge in the right, the shot in the left hand. As soon as the sponge is withdrawn, he faces to his left, and puts the ammunition into the muzzle, taking care that the seam of the cartridge does not come under the vent, and then steps back, commencing with his left foot, to his position outside the wheel, in the same manner that No. 1 does. At the command READY, he breaks well off to his right with the right foot, bending the right knee, and straightening the left leg; the body erect on the haunches, and fixes his eyes on the muzzle. The piece having been fired, No. 2

rises on his left leg, remains facing the piece until he hears the command LOAD, or observes the flash of the gun, then steps in, and performs his duty as before. At the command CEASE FIRING, he takes his position outside the wheel, and faces to the front. With the howitzer, No. 2 puts in the charge, so that the fuze may rest against the rammer head, and No. 1 sets it home carefully.

106. Serving the vent. The instructor places No. 3 on the right of the piece, indicates the following objects, and explains their uses: TUBE POUCH; THUMB STALL; PRIMING WIRE; GUNNERS' GIMLET; FRICTION PRIMER; LANYARD: lanyard hook; VENT: vent field; BREECH: cascable, knob, and neck of cascable. He then commands: To YOUR POSTS. No. 3 stands in line with the knob of the cascable, covering No. 1, the priming wire in his right hand, thumb through the ring, the thumb stall on the left thumb, the tube pouch fastened to the waist. Load. At this command he steps to his left, wipes the vent field with the thumb stall, which he then holds pressed upon the vent, keeping his elbow raised; his fingers on the left side of the piece, so as to allow the gunner to point over his thumb; the right hand on the tube pouch. When the piece is sponged, and the charge inserted by No. 2, he jumps to the end of the trail handspike, and, seizing it with both hands, prepares to move it to the right or left, on a signal from the gunner, who taps the right of the trail for a movement to the left, and the left of the trail for a movement to the right. As soon as the piece is pointed, the gunner raises both hands as a signal to No. 3, who then resumes the position to your posts. Ready. At this command,

he steps in to the piece, pricks the cartridge, taking care not to move the charge, and covers the vent with his left hand as soon as the tube is inserted. At the command FIRE, he steps to his right, clear of the wheel, and at the flash of the gun, or at the command LOAD, serves vent as before. No. 3 should be careful to keep the vent closed from the time the sponge enters the muzzle until the charge is inserted by No. 2.

107. Firing. The instructor places No. 4 on the left of the piece, equips him with a tube pouch, and repeats the nomenclature as for No. 3. He then commands: To YOUR POSTS. No. 4 stands in line with the knob of the cascable, and covering No. 2. Load. At this command, No. 4 inserts the lanyard hook into the ring of a primer, and stands fast. Ready. At this command, he steps in with the right foot, drops the tube in the vent, takes the lanyard in his right hand, moves to the rear so far as to keep the lanyard slack, but capable of being stretched, without altering his position, which should be clear of the wheel, left foot broken to the left and rear. Fire. As soon as No. 3 is clear of the wheel, No. 4 pulls the lanyard briskly and firmly, passing the hand, back up, in a downward direction to the rear, so as to keep the lanyard hook from flying back in the direction of the face. Should the tube fail to explode the charge, the gunner immediately commands, Don't advance, the primer has failed. Upon which No. 2 steps inside the wheel, close to the axle-tree, receives from No. 3 over the wheel a priming wire, and from No. 4 a prepared primer, pricks, primes, and resumes his post. At the command, Cease firing, No. 4 secures his lanyard.

108. No. 3, as well as No. 4, should be equipped with a tube pouch, furnished with friction primers and lanyards. In the absence of No. 4, immediately after pricking the cartridge, he prepares and inserts a tube, steps to his post, faces the vent, breaks to his rear with the left foot, and at the command FIRE, discharges the piece. He then resumes his post, and tends the vent as before.

109. Serving ammunition. The instructor stations No. 5, covering the left wheel, 5 yards in rear of it, and No. 7 in rear of and near the left limber wheel; No. 6 is stationed in rear of the limber chest, and issues the ammunition. He is provided with a fuze-gouge, and prepares the shell and spherical case shot according to the distance or time ordered, before delivering it to No. 5. To cut the fuze. Place the projectile between the knees, fuze uppermost, and support it with the left hand. Holding the fuze-gouge in the right hand, place the left corner of its edge close to, and on the right of the graduated mark indicating the time desired; then cut away gradually until the composition is exposed for a length about equal to the width of the gouge. Great care must be taken not to expose the composition to the left of the proper graduation mark, and to this end particularly avoid commencing to cut too close to the desired mark; for after the composition is once exposed it is very easy to pare away to the left, if the time has not been accurately cut. When time permits, it is well to expose the composition fully, either by cutting the opening larger, towards the right, or (with shells only) by cutting another opening to the right of the first. It

is in all cases better to enlarge the first opening, and always by extending it towards the right. Care must be taken not to cut the fuzes more rapidly than the demand for shells and Shrapnell shot requires. At the command LOAD, No. 5 runs to the ammunition chest, receives from No. 7 or No. 6 a single round, the shot in the right hand, the cartridge in his left; takes it to the piece and delivers it to No. 2; returns immediately for another round, and then halts at his post until the piece is fired. In firing shells or spherical case, he exhibits the fuze to the gunner before delivering the charge to No. 2. When ammunition pouches are used they are worn by Nos. 5 and 7, hung from the left shoulder to the right side; the round is placed in the pouch by No. 6 or No. 7, so that the cartridge will be to the front. When it is brought up No. 5 holds open the pouch, and No. 2 takes out the round with both hands. In rapid firing, with round shot and canister, Nos. 5 and 7 may alternate in delivering the charges to No. 2, especially when the ammunition is issued direct from the caisson. At the command CEASE FIRING, No. 5 carries the round back to No. 6. No. 6 will be careful not to raise the lid unnecessarily. It should be kept closed when possible. In firing shells and spherical case, he prepares each fuze as directed, assisted when necessary by No. 7. He gives No. 5 the time or distance of the fuze with each round issued, who reports to the gunner before delivering it to No. 2. At the command CEASE FIRING, he carefully replaces the ammunition in the chest, and secures the lid.

110. Loading by detail. For the instruction of recruits united for the service of the gun, the exercise is conducted by

detail, the instructor giving all the commands. His commands are, Load by detail-LOAD; TWO, THREE, FOUR: SPONGE; TWO, THREE, FOUR: RAMI; TWO, THREE; READY; FIRE; CEASE FIRING. When the men are sufficiently instructed to go through the manual, without detail, the commands of the instructor for that purpose, are-LOAD; COMMENCE FIRING; CEASE FIRING; Or, simply, COMMENCE FIRING, and CEASE FIRING. After the command COMMENCE FIRING, the action is continued as laid down for loading without detail, until the command CEASE FIRING is given, which is repeated by the chief of the piece and the gunner.

MOVING THE PIECE BY HAND. PIECE UNLIMBERED.

111. To the front. The instructor commands: 1. By hand to the front. 2. MARCH. 3. HALT. At the first command, the gunner seizes the end of the handspike, and Nos. 1, 2, 3, and 4 the spokes of the wheels. No. 1, with his left hand; Nos. 2, 3, and 4 with both hands; No. 1 holds the sponge with his right hand, the staff resting upon his right shoulder, sponge head down. At the second command they move the piece forward, the gunner raising the trail until the command HALT is given, when all resume their posts.

112. To the rear. The instructor commands: 1. By hand to the rear. 2. MARCH. 3. HALT. At the first command, the gunner, facing to the rear, seizes the handspike with his right hand; Nos. 1, 2, 3, and 4 seize the wheels as before, except that No. 1, holding the sponge in his left hand, uses his right at the

wheel. At the command MARCH, they move the piece to the rear, the gunner raising the trail, until the command HALT is given, when all resume their posts.

CHANGING POSTS.

113. In order to instruct the men in all the duties at the piece, the instructor causes them to change posts. For this purpose he commands: 1. Change posts. 2. MARCH. At the command Change posts, the men on the right of the piece face to the rear; those who have equipments lay them down; No. 1 resting the sponge head on the nave of the wheel. At the command MARCH, each man takes the place and equipments of the man in his front. No. 1 takes the place of No. 3. No. 3 “ “ of No. 8. No. 8 “ “ of No. 6. No. 6 “ “ of No. 7. No. 7 “ “ of No. 5. No. 5 takes the place of No. 4. No. 4 “ “ of No. 2. No. 2 “ “ of No. 1. The gunner changes with one of the numbers by special direction of the instructor. A sufficient number of the most intelligent cannoneers must be kept instructed to serve as gunners.

114. Equipments. The gunner, who is responsible for the equipments, either distributes them from the limber chest, or they may be hung on the neck of the cascable, and distributed by him to the proper numbers, at the command TAKE EQUIPMENTS, from the instructor. He receives them again at the command REPLACE EQUIPMENTS, making such disposition of them as may be directed.

LIMBERING.

115. To the front. The instructor designates the following parts of the carriage: STOCK: trail, trail handles, trail plate, lunette, washer hook for handspike, large pointing ring, small pointing ring, sponge and rammer stop, sponge chain and hasp, ear plate for sponge chain hasp, handspike ring, sponge hook. He then commands: LIMBER TO THE FRONT. At this command, No. 1 steps up between the muzzle and the wheel, by the oblique steps indicated for loading; turns the staff, seizing it with the left hand, at the same time shifting his right, the back of the right up, that of the left down, and passes the sponge on its hook; rammer head to the rear, to No. 3, who receives the head, secures it against the stop, and keys it up. The piece is then brought about by the cannoneers, and the limber, inclining to the right, passes to its place in front of it, being drawn, when it is not horsed, by Nos. 6 and 7, who take hold at the end of the pole for the purpose. To bring the piece about, the gunner and No. 5 pass to the right of the handspike, and, facing towards the left, seize it, the gunner near the end, and No. 5 at the middle, and on his right, raise the trail and carry it round to the left; Nos. 1 and 2 bear down upon the muzzle, and Nos. 3 and 4, each using both hands, bring the wheels round; No. 3 turning the right wheel to the rear, and No. 4 the left wheel to the front. When the piece is brought about, the trail is lowered; Nos. 3 and 4 step within the wheels to avoid the limber; Nos. 1 and 2 remain at the muzzle, and the gunner and No. 5 step between Nos. 3 and 4 and the trail, the gunner first taking out the handspike, and passing it to

No. 4, by whom it is put up. As soon as the limber is in front of the piece, the gunner commands: HALT, LIMBER UP; upon which the limber halts, the gunner and No. 5 raise the trail by means of the handles, and, assisted by Nos. 3 and 4 at the wheels, and Nos. 1 and 2 at the head of the carriage, run the piece forward, and place the lunette upon the pintle; the gunner then puts in the key, and all take their posts; when necessary, Nos. 6 and 7 assist at the trail in bringing the piece about, and in limbering up.

116. To the right, (or left.) The instructor commands: LIMBER TO THE RIGHT, (or LEFT.) The trail is turned to the right, (or left,) and the piece limbered up as before; the limber inclining to the right, (or left,) and taking its place by a right (or left) wheel.

117. To the rear. The instructor commands: LIMBER TO THE REAR. The limber inclines to the right, and takes its place by wheeling about to the left, and the piece is then limbered up as before.

POSTS OF THE CANNONEERS. PIECE LIMBERED.

118. Nos. 1 and 2 are opposite the muzzle; Nos. 3 and 4 opposite the knob of the cascable; the gunner and No. 5 opposite the rear, and Nos. 6 and 7 opposite the front parts of the limber wheels; No. 8 is on the left, and opposite the limber chest of the caisson. All face to the front, and cover each other in lines 1 yard from the wheels; the even numbers on the right, the odd numbers on the left. The chief of the

piece is on the left, and, if not mounted, opposite the end of the pole; if mounted, he is near the leading driver, and on his left.

TO FORM THE DETACHMENT.

119. To the front. The instructor commands: DETACHMENT-FRONT. The gunner commands: Cannoneers, forward, MARCH; the even numbers move directly to the front; the odd numbers closing on them when clear of the piece. The gunner files them to the left, and fronts the detachment at the proper distance. No. 8 moves directly forward, and takes his place in the detachment. To the rear. The instructor commands: DETACHMENT-REAR. The gunner commands: Cannoneers, rear FACE-MARCH. At the command MARCH, the odd numbers move directly to the rear, the even numbers closing on them, and the detachment is filed to the left, halted at a proper distance by the gunner, and faced to the front; No. 8 taking his proper place in the detachment. In forming detachments in line, they are always, after halting, dressed to the right by the gunner.

POSTS OF THE DETACHMENTS AT THEIR PIECES.

120. In front. The detachment is in line facing to the front, 2 yards from the end of the pole or the lead horses. In rear. The centre of the detachment is 2 yards behind the muzzle, and facing to it. On the right or left. The detachment is in line opposite the limber axletree, and 3 yards from it. In horse artillery, it is in line with and 3 yards from the leading

horses. In all cases it faces to the front.

CHANGE OF POSTS OF DETACHMENTS AT THEIR PIECES.

121. From front to rear. The detachments being in line, in front of their pieces, to post them in rear, the instructor commands: DETACHMENTS-REAR. The gunner commands: Cannoneers, rear FACE, MARCH. At the command MARCH, Nos. 1, 2, 3, and 4 oblique sufficiently to the left, and Nos. 5, 6, 7, and 8 to the right, move along the sides of their piece; re-unite as soon as they have passed it, and are halted at the proper distance, faced to the front, and aligned to the right by the gunner. From rear to front. The instructor commands: DETACHMENTS-FRONT. The gunner repeats the command, and adds-MARCH. At this command, the cannoneers oblique; Nos. 1, 2, 3, and 4, to the left; Nos. 5, 6, 7, and 8 to the left; pass their piece, re-unite in front, and are halted and aligned to the right by the gunner. From rear to right, (or left.) The instructor commands: DETACHMENTS-RIGHT, (or LEFT.) The gunner commands right (or left) oblique, MARCH, and afterwards FORWARD, and HALT, in time to bring the detachment to its post on the right or left. He then aligns it to the right.

122. In horse artillery, to change from front to rear, the gunners command: Left reverse, MARCH; FORWARD: Left reverse, MARCH; HALT. From rear to front. The gunners command: Right oblique, MARCH; FORWARD. Left oblique, MARCH; FORWARD; HALT. From rear to right,

(or left.) The gunners command: Right (or left) oblique, MARCH; FORWARD; HALT. From right (or left) to rear. The gunners command: Right (or left) reverse, MARCH; FORWARD; Right (or left) reverse, MARCH; HALT. If the piece is moving when the change of post is ordered, the gunner halts or slackens the pace until it passes, and then commands: Left (or right) oblique, MARCH; FORWARD. The commands of the instructor are the same as in foot artillery. The movements are executed in the same manner when the detachments are dismounted.

TO POST THE CANNONEERS AT THE PIECES LIMBERED.

123. The detachment being formed in line in front or rear, on the right or left, the instructor commands: CANNONEERS, TO YOUR POSTS. From the front. The gunner faces the detachment to the right, and commands: To your posts, MARCH. At this command, the cannoneers, Nos. 1 and 2, turning to the right, and opening out, file to their posts; halt at their proper places, and face to the front. From the rear, right or left. At the command CANNONEERS TO YOUR POSTS, the gunner, in each case, faces the detachment to the left, and marches the cannoneers by that flank to their posts.

MOVING THE PIECE BY HAND. PIECE LIMBERED.

124. To the front. The instructor commands:

1. FORWARD. 2. MARCH. 3. HALT.

At the first command, Nos. 6 and 7 seize the end of the pole with both hands, the gunner and No. 5, facing towards the pole, seize the splinter bar with one hand, and the pole with the other; Nos. 3 and 4 seize the spokes of the hind wheels with both hands, and Nos. 1 and 2 apply both hands at the head of the carriage. At the second command, all acting together, urge the piece forward until the command HALT is given, when all resume their posts. 125. To the rear. The instructor commands:

1. BACKWARD. 2. MARCH. 3. HALT.

At the first command, all face to the rear; Nos. 6 and 7 seize the end of the pole with both hands; No. 5 and the gunner seize the spokes of the limber, and Nos. 1, 2, 3, and 4 those of the hind wheels. At the command MARCH, all moving together, move the piece to the rear, Nos. 6 and 7 keeping it straight by the use of the pole. At the command HALT, all resume their posts.

UNLIMBERING, AND COMING INTO ACTION.

126. To the front. The instructor commands: ACTION FRONT. At this command, the gunner takes out the key, and, assisted by No. 5, raises the trail from the pintle, and then commands DRIVE ON, upon which Nos. 6 and 7 reverse the limber to the left, and proceed with it to the rear; again reverse to the left, and halt so that the limber shall

cover the piece, with the end of the pole 6 yards from the end of the trail handspike. At the same time that the limber moves off, the piece is brought about in all respects as in limbering to the front, except that the gunner and No. 5, without lowering the trail, carry it about, each by means of the handle on his own side. Nos. 6 and 7, when necessary, assist at the trail, after placing the limber in position. As soon as the piece is brought about, and the trail lowered, No. 4 takes out the handspike and passes it to the gunner, who fixes it in the trail. No. 1 takes out the sponge, No. 3 unkeying it, and No. 4 prepares his lanyard. All then resume their posts.

127. To the right, (or left.) The instructor commands: ACTION RIGHT, (or LEFT.) The piece is unlimbered, and placed in the required direction, and the limber wheels to the left, (or right,) and takes its place in rear, by reversing to the left, (or right.)

128. To the rear. The instructor commands:

1. Fire to the rear. 2. IN BATTERY.

At the command IN BATTERY, the piece is unlimbered as before; the trail immediately lowered, and the gun prepared for action; the limber moves directly forward at the command DRIVE ON, from the gunner, and takes its place by coming to the left about.

SERVICE OF THE GUN WITH DIMINISHED NUMBERS.

129. The men should be frequently exercised in serving pieces with diminished numbers, that each may know the duties he has to perform in such cases. Disabled men are replaced as soon as possible by the highest numbers, or, if men are selected to replace them, the highest numbers will be reduced to fill the vacancies thus created. During action, Nos. 1 and 2 may occasionally change places and numbers, as the duties of No. 1 are very severe.

130. Service of the gun by two men. The gunner commands, points, serves the vent, and fires; No. 1 sponges, loads, and serves ammunition.

Three men. The gunner commands, points, serves the vent, and fires; No. 1 sponges; No. 2 loads, and serves ammunition.

Four men. The gunner commands and points; No. 1 sponges; No. 2 loads, and serves ammunition; No. 3 serves the vent, and fires.

Five men. The gunner commands and points; No. 1 sponges; No. 2 loads; No. 3 serves the vent, and fires; No. 4 serves ammunition.

Six men. The gunner commands and points; No. 1 sponges; No. 2 loads; No. 3 serves the vent, and fires; Nos. 4 and 5 serve ammunition.

Seven men. The gunner commands and points; No. 1 sponges; No. 2 loads; No. 3 serves the vent, and attends to the trail; No. 4 fires; No. 6 is at the limber, serves ammunition to No. 5, and occasionally changes with him.

Eight men. No. 7 assists No. 6; the other numbers as before

TABLE FOR THE EXERCISE WITH DIMINISHED NUMBERS.

Nos. retained.	Distribution of duties.							
	Gunner.	1	2	3	4	5	6	7
G. 1.....	G. 3,4	1,2,5
G. 1, 2.....	G. 3,4	1	2, 5
G. 1, 2, 3.....	G.	1	2, 5	3, 4
G. 1, 2, 3, 4.....	G.	1	2	3, 4	5
G. 1, 2, 3, 4, 5.....	G.	1	2	3, 4	6	5
G. 1, 2, 3, 4, 5, 6.....	G.	1	2	3	4	5	6
G. 1, 2, 3, 4, 5, 6, 7..	G.	1	2	3	4	5	6	7

131. When it is likely that movements must take place on the field, or the firing is slow, and it can be done without inconvenience, ammunition will be served direct from the rear chest of the caisson, No. 8 performing the duties prescribed for No. 6 at the limber chest. At convenient moments, the ammunition served out by No. 6 will be replaced from the rear caisson chest. If the ammunition chest at the piece is exhausted, the limber is replaced by that of the caisson, and the empty chest exchanged for the centre one of the caisson. As a rule, the limber chests, and especially that of the piece, will be kept full at the expense of the others, so that in case of a sudden movement on the field there shall always be a sufficient supply of ammunition at hand.

APPENDIX B - COMMANDS FOR BATTERY FIRING

The following information is based on French, Hunt and Barry, Instructions for Field Artillery, 1860. Information on commands for firing can be found in paragraphs No. 97 (School of the Piece), No. 477 (School of the Section) and No. 548 (School of the Battery). Chiefs of the Piece and Chiefs of Section can be omitted when not present.

Note that in the commands for firing by piece, section and battery, the preparatory command is given by the captain and relayed by the Chiefs of Section (or Half-Battery). If the Chiefs of Section are not present, the gunners will repeat the preparatory commands. The command to fire is given by the captain.

“COMMENCE FIRING”

1. Captain: “Load with (type of ammunition), commence firing”
2. Chief of Section: “Load with (type of ammunition), commence firing”
3. Chief of Piece: “Load with (type of ammunition), commence firing”
4. Gunners: “Load with (type of ammunition), Load, Ready, Fire.”

After firing, the pieces will continue to be loaded until the command to “Cease Firing” is given.

“DIRECTED” FIRING

1. Captain: “Load with (type of ammunition), Load”
2. Chief of Section: “Load with (type of ammunition), Load”
3. Chief of Piece: “Load with (type of ammunition), Load”
4. Gunners: “Load with (type of ammunition), Load, Ready.”

The pieces are then fired upon command from the Captain as follows:

To Fire By Battery:

1. Captain: “Fire By Battery”
2. Chief of Section: “Fire By Battery”
3. Captain: “Battery – Fire.”

On the Captain’s command to fire the No. 4’s fire their pieces.

To Fire By Half-Battery:

1. Captain: “Fire By Half-Battery”
2. Chief of Right Half-Battery: “Fire By Half-Battery. Right Half-Battery”
Chief of Left Half-Battery: “ Fire By Half-Battery. Left Half-Battery.”
3. Captain: “Right (or Left) Battery – Fire.”

On the captain’s “Fire” command, the No. 4’s of the designated half-battery fire. The other half-battery is then fired as designated by the Captain.

To Fire by Section:

1. Captain: “Fire by Section”
2. Chief of Right Section: “Fire by Section. Right Section.”
Chief of Center Section: “Fire by Section. Center Section.”
Chief of Left Section: “Fire by Section. Left Section.”
3. Captain: “Right (Center or Left) Section -- Fire”

On the Captain’s command to “Fire” the No. 4’s in the designated section will fire together. The other sections are fired as designated by the Captain.

To Fire by Piece:

1. Captain: “Fire by Piece.”
2. Chief of Right Section: “Fire by Piece. Right Section.”
Chief of Center Section: “Fire by Piece. Center Section.”
Chief of Left Section: “Fire by Piece. Left Section.”
3. Captain: “Right (Center or Left) Section, Right (or Left) piece -- Fire.”

On the Captain’s command to “Fire” the No. 4 of the designated piece will fire. The remaining pieces will fire as designated by the Captain.

“CEASE FIRING”

In all battery firings, the detachments will begin to reload immediately after their piece has fired. Since the NPS requires a ten-minute interval between firings, another round will not be advanced to the piece. The piece can be secured by No. 1 and No.3 as described in Part IV during this “reloading” procedure.

APPENDIX C - DRILL FOR THE MODEL 1841 MOUNTAIN HOWITZER

MANUAL OF THE PIECE

The movements and motions for each member of the detachment are given as per Instruction for Mountain Artillery, 1851 and Manual for Light Artillery, 1863. The manual for the piece herein presented incorporates modifications of the field artillery drill and the mountain artillery drill, with additional techniques developed by National Park Service employees for safely firing muzzle-loading artillery. In order to preserve as much authenticity as possible, the wording was used excepting where clarification was needed or where changes were made for the sake of safety.

Most of the procedures for safely maintaining, inspecting and using this piece are the same as all other 19th Century artillery. The drill and other procedures and examinations below differ in some way from those above.

SERVICE OF THE PIECE

The piece is in battery, the men at their posts. The chest when the limber is absent, are on the ground, ten yards behind the line of the axletree, their sides parallel to the axis of the piece, backs together, and the turnbuckles outside. When the limber is used, its axletree shall be at least ten yards to the rear of, and covering, the axletree of the piece, the pole or shafts pointing to the front.

Equipments. The Gunner, who is responsible for the equipments, either distributes them from the limber chest or they may be hung on the neck of the cascable. At the command "TAKE EQUIPMENTS", the Gunner distributes the equipments. Number 1, with the assistance of No. 3, takes out the sponge. The Gunner equips himself with the belt and pouch (on left hip) containing the hausse and priming wire and, with the finger-stall, wearing the last on the second finger of the left hand. When he takes his position, he puts on the finger-stall and removes the hausse and priming wire. The hausse, when used, is held in the left hand; the priming wire in the right, thumb through the ring points to the rear. Number 3 wears the tube pouch containing the friction tubes and the lanyard on his left hip. Numbers 2 and 4 wear haversacks hung from the right shoulder to the left side. The command is then "TO YOUR POSTS".

COMMANDS FOR LOADING AND FIRING

TRAINING AND INSTRUCTION

For the purposes of instruction of the detachment, or if desired to show the drill step-by step to the visitors, “Load by detail” may be used. This procedure may not be used when firing blank or live rounds. Although instructive for No. 1 and No. 2 cannoneers, this loading procedure can seem disjointed and time consuming for other members of the detachment and should be discontinued as soon as possible to let the detachment experience the normal flow of the drill.

In this procedure, the commands may be given by the Chief of Section, Chief of the Piece or the Gunner. Each member of the detachment performs his duties with the commands, which are: “Load by Detail—LOAD; two, three four: SPONGE, two three four: RAM, two, three; READY; FIRE; CEASE FIRING.”

DUTIES OF NUMBER 1

Until the command LOAD, No. 1 stands square to the front, buttons on a line with the muzzle, holding the sponge about the middle of the staff in his right hand, and trailing it at an angle of 45 degrees, sponge head up. The sponge bucket sites on the ground beneath the forward part of the tube.

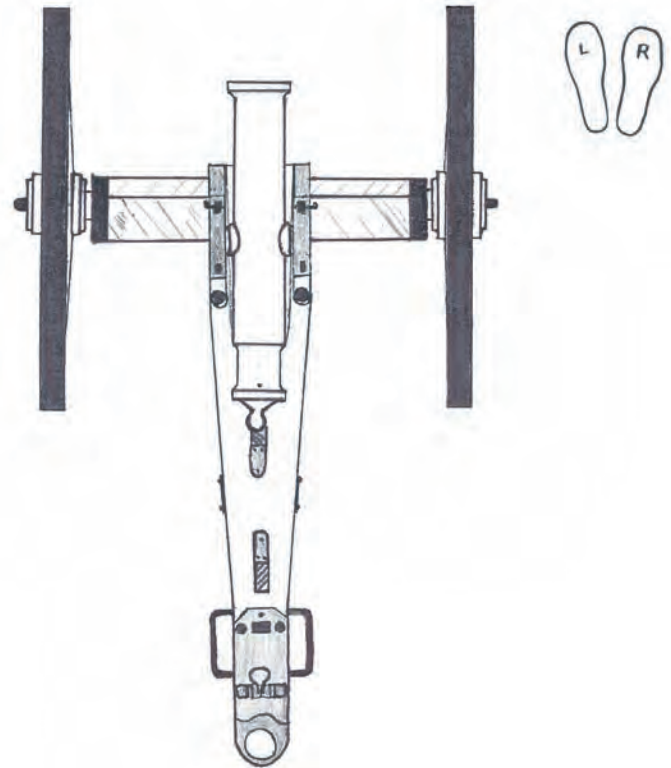

First Motion – At the command LOAD, No. 1 faces to the left, steps obliquely to the right with his right foot, without moving his left, and at the same time brings the sponge smartly to a perpendicular position by drawing his right hand up in line with the elbow. The sponge is grasped firmly in the hand, and the rammer head kept just over the right toe, the elbow close to the side. (Note: depending upon the stature of No. 1, he may either place his right foot on a line with the wheel, or he may step inside the line of the wheel.)

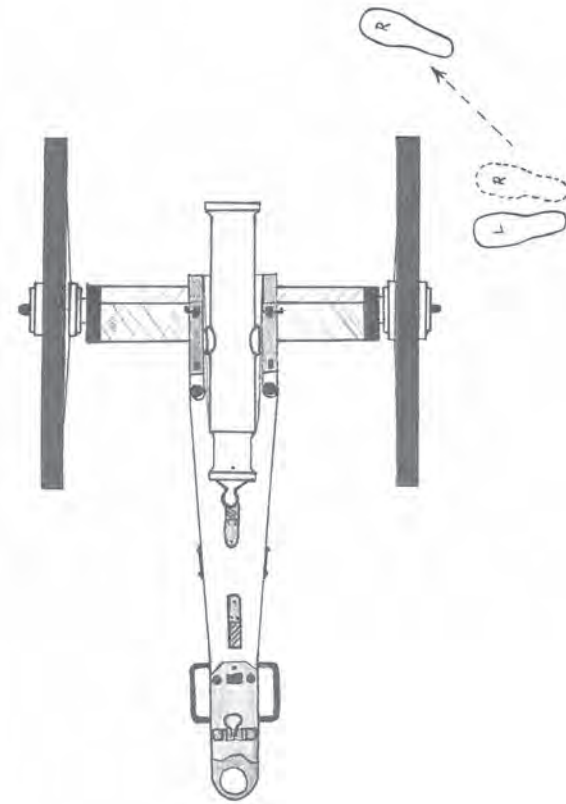
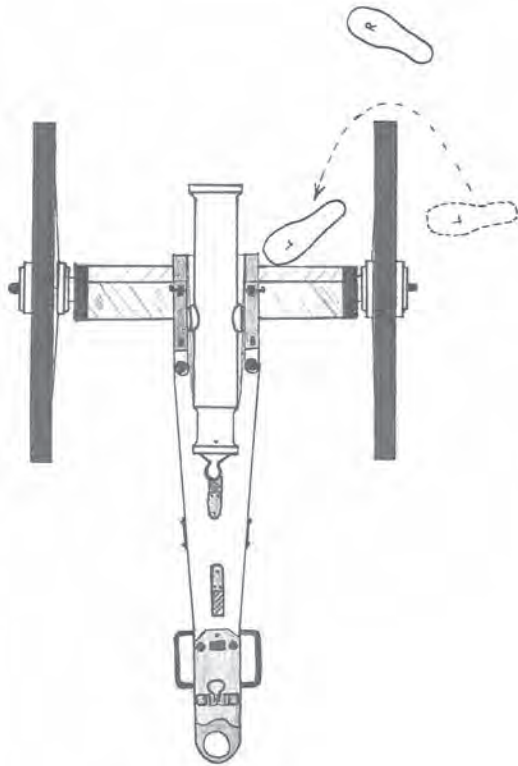

Second Motion – With his left foot, he steps around and inside the wheel and plants his foot near the axletree about halfway between the wheel and the piece.

Third Motion – He brings his right foot on a line with the left and about 30 inches (or a comfortable distance to maintain balance) from it. He dampens the sponge and, bending his right knee, brings the sponge to a horizontal position extending the hands to the ends of the staff, the sponge head to the left, the back of the right hand up, and that of his left down, the sponge head against the bottom of the face of the piece.

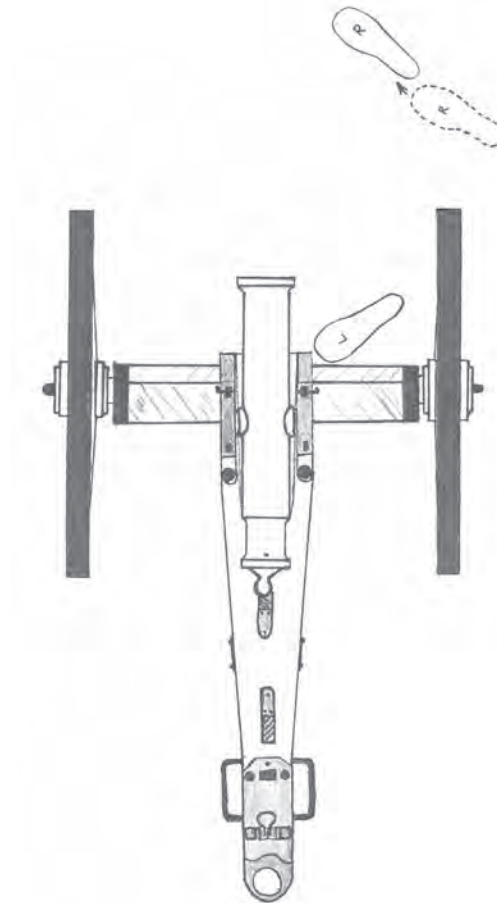

Fourth Motion – He inserts the sponge head, drops the left hand behind his thigh, shoulders square and parallel with the tube, feet equally turned out, straightens the right knee, and, bending over the left, forces the sponge home.

SPONGE

At this command, No. 1 fixes his eye on the vent to see that it is closed, gives two turns of the sponge to the rights and two to the left, taking great care to press it at the same time against the bottom of the bore.

Second Motion – He draws out the sponge, pressing on the bottom of the bore, at the same time straightening his left knee, and bending his right; seizes the staff near the sponge against the face of the piece.

Third Motion – He turns the sponge by bringing his hands together in the middle of the staff, giving it a turn with each hand, moving the sponge head over, at the same time turning his wrist, which brings the staff horizontal, and extending his hands to the ends of the staff, back of the left up, that of the other down, the right thumb extended along the staff. He places the rammer head against the bottom of the face of the muzzle.

(Note: During the whole time of sponging, number 1 keeps his eye on the vent. If at any time it is not closed, he will discontinue the maneuver and command: STOP VENT.)

Fourth Motion – He introduces the rammer head into the muzzle, as soon as No. 2 has inserted the charge, and joins his left hand to his right, casting his eyes to the front.

RAM

At this command, No.1 rams home, throwing the weight of his body with rammer; bending over his left knee and passing his left arm (with the elbow slightly bent and the back of the hand up) in a horizontal position over the piece until it points in the direction of the rear part of the left wheel (the right shoulder thrown back and the eyes cast toward the front) until the cartridge is home. (Note: One object of joining the hands on the staff to start the ramming motion and of casting the eyes to the front, is to throw back the right shoulder. This, along with throwing the left hand over the tube, will keep the shoulders parallel with the bore as a safeguard in the event of premature discharge.)

Second Motion – He quickly moves the sponge out with his right hand, allows it to slide through the hand as far as the middle of the staff, grasps it firmly, seizes it close to the rammer head with the left hand (back of the hand up), and places the rammer head against the face of the piece (both knees straight; eyes to his own front).

Third Motion – He then draws the sponge close to his body and immediately steps back outside the wheel—first with the left foot (around the wheel), then with the right so that when the right foot is brought to the left his buttons are on a line with the muzzle. He is about one foot outside the wheel facing towards the right wheel of the gun.

(Note: Stepping back with the right foot first tends to increase No. 1's space from the wheel, which in turn causes No. 3 to be too far from the vent when the drill is repeated a second time.)

In drawing the right foot to the left, he gives the sponge a turn with his left hand, at the same time stopping it, and brings the sponge to a trail in the right.

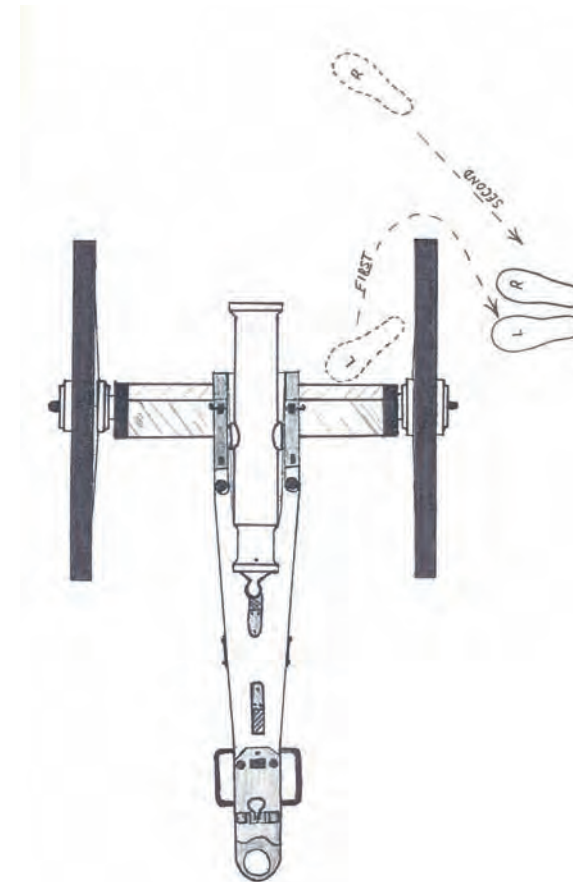

READY – At this command, which is given as soon as the piece is loaded, No. 1 breaks off to his left with his left foot, bending the left knee and straightening the right leg, drops the end of the sponge staff into the left hand (back of the hand down) and fixes his eyes on the muzzle.

The heels should be parallel to the wheel, the body erect on the haunches and the sponge and rammer held in both hands in a horizontal position, sponge head to the left.

The piece having been fired, No. 1 rises on his right leg and returns to his position, as in **TO YOUR POSTS**”.

DUTIES OF NUMBER 2

Until the command **LOAD**, No. 2 stands square to the front, buttons on a line with the muzzle. On this command being given, he faces about and goes to the ammunition chest, gets a round from the chest and returns to the piece. Facing the wheel, buttons on a line with the muzzle, he steps obliquely to his left with his left foot without moving his right. (If No. 4 is present, he takes his round to the piece and No. 2 remains at the limber or chest, left side, to tend it. No. 4 takes the position described for No. 2 facing the wheel and follows through Motions 2 and 3, etc.)

Second Motion – With his right foot, he steps around and inside the wheel, and plants his foot near the axletree about halfway between the wheel and the piece.

Third Motion – He brings his left foot on a line with the right and a comfortable distance from it. As soon as the sponge is withdrawn, he inserts the charge into the muzzle, taking care that the seam of the cartridge does not come under the vent, and then steps back, commencing with his right foot, to his position outside the wheel. (If the charge is a blank round, he should be sure that the powder end is inserted first.)

At the command READY, he breaks well off to his right with the right foot, bending the right knee, and straightening the left leg (the body erect on the haunches), and fixes his eyes on the muzzle. His left hand is placed on his left thigh and his right hand on his right knee.

The piece having been fired, No. 2 rises on his left leg and remains facing the piece until he hears the command LOAD. At the command CEASE FIRING, he faces to the front.

DUTIES OF NUMBER 3

No. 3 stands to the right and opposite to the lunette, facing the front, covering No. 1. He holds the handle of the lanyard in the right hand, the cord passing between the fingers, the hook between the forefinger and thumb. He wears the tube pouch on the left hip.

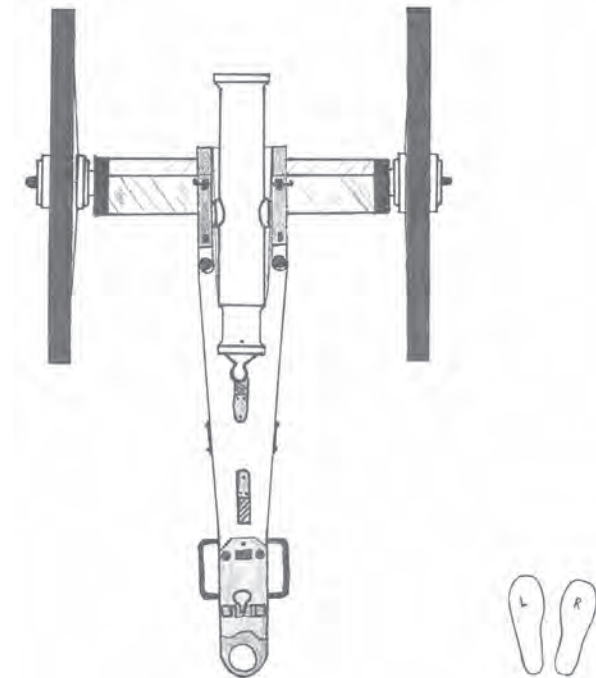

At the command LOAD, he takes a friction tube in the left hand, and passes the hook of the lanyard through the eye of the tube from right to left, continuing to hold the hook between the thumb and forefinger.

At the command READY, he does a half-face to the left, steps up with the right foot, taking care to stay outside the wheel, and with the left hand inserts the tube in the vent. He steps back with the right foot a full pace and breaks to his rear a full pace with the left foot. He holds the lanyard slightly stretched, the handle at the height of the knee, back of the hand up, the left hand against the thigh.

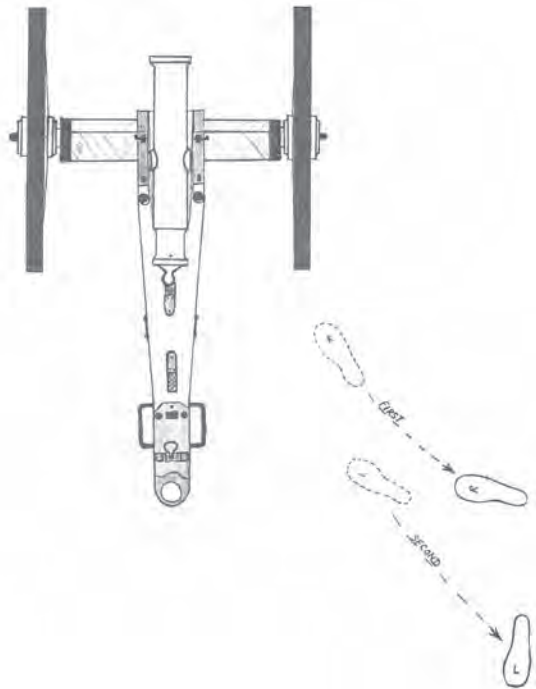
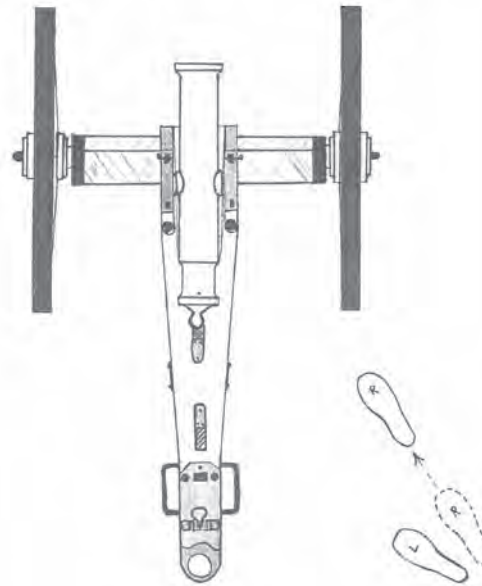

When ready to fire, he nods to No. 3 and then turns his face toward the rear so as to protect his eyes from the lanyard hook.

At the command FIRE, he gives a smart pull upon the lanyard, utilizing his body weight, being careful to keep the hand low with back up, and in front of his knees.

(Note - The point of pulling the lanyard in front of, instead of behind the knees can be argued. The method presented is considered safer for No. 1, whose eyes stand to be struck by the hook when the pull is behind the knees.)

At the command CEASE FIRING, he winds the lanyard upon its handle, and if dry, puts it in the tube pouch.

DUTIES OF THE GUNNER

The Gunner gives or repeats the commands of execution. At the command to commence firing, he gives the word LOAD, half-faces to his right, plants the left foot opposite to the knob of the cascable. He places his right knee upon the ground near and on the left of the trail; places the hausse when it is used; seizes the lunette with the right hand to give direction; and at the same time tends vent with the second finger of the left hand. The thumb is on the base of the breach.

As soon as the piece is loaded and aimed, he removes the hausse with his left hand, rises on his left leg and pricks the cartridge *;

*(*The Gunner holds the priming wire below the loop between the thumb and index finger of his right hand. Without putting his thumb through the loop, he inserts the wire into the vent and pricks the cartridge with a single firm stroke. Still holding the wire in the same manner, he removes it from the vent.)*

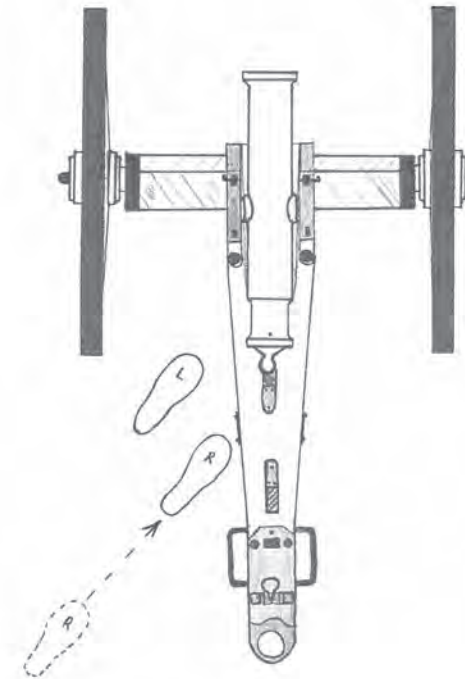
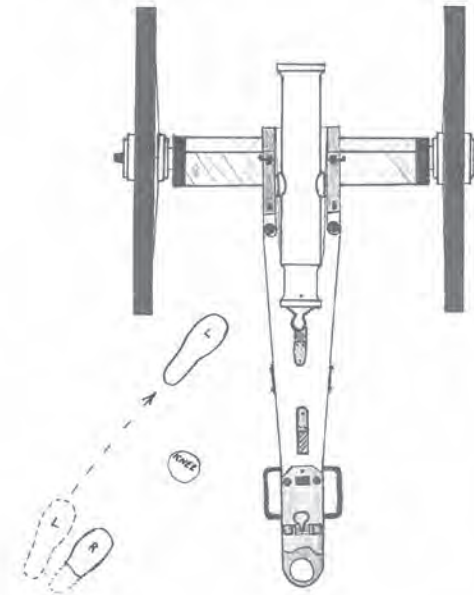

gives the word READY, steps back first with the right foot, then the left, and returning to his original position outside the wheel, breaks to his left with the left foot so as to observe the effect of the shot. He observes that No.3 is in position with the lanyard slightly stretched and at the nod of No. 3, the Gunner commands FIRE.**

*(**As an added precaution, the Gunner looks toward No. 3 to make certain that he is ready. No. 3 gives a nod of the head signaling the Gunner to give the command to FIRE.)*

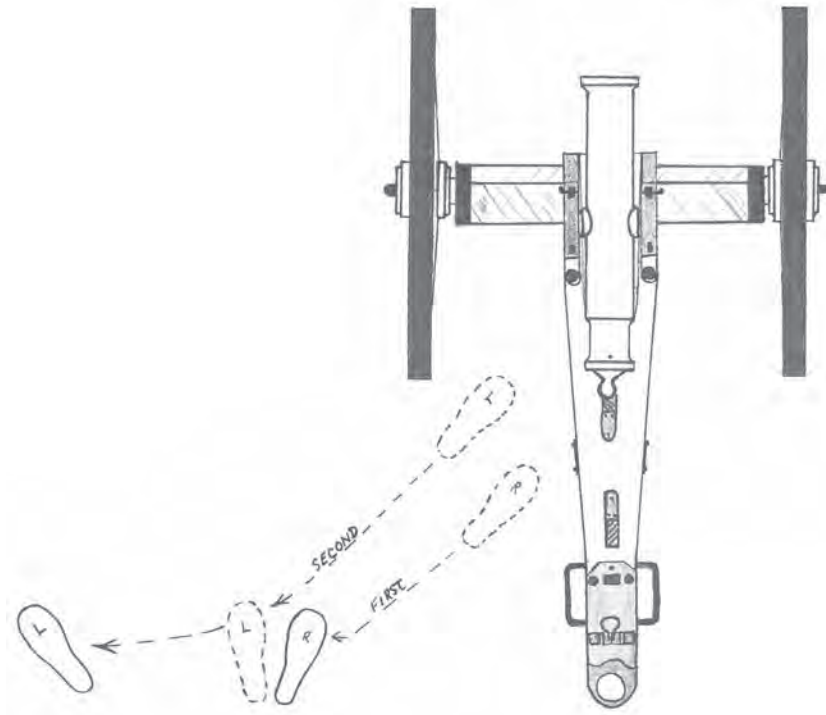

DUTIES OF NUMBER 4

If No. 4 is available, he stands square to the front on the left side of the chest or limber. At the command LOAD, he gets a charge from the chest (or from No. 5) and places it in his haversack. He then walks forward to the piece, Nos. 2 and 4 passing each other on their right. Upon reaching the gun, he assumes a position facing the wheel on a line with the muzzle. He follows the procedures as described for No. 2.

DUTIES OF NUMBER 5

If No. 5 is available, he stands square by the front on the right side of the chest or limber. At the command LOAD, he opens the chest, removes a charge and hands it, using both hands, to No. 4. He then closes the chest and stands watch over it.

LEVEL I MISFIRE PROCEDURES

PRAIRIE CARRIAGE

In case of a misfire, the Gunner calls out, "Do not advance, the primer has failed." Thirty seconds after the last wisp of smoke from the vent, the Gunner will call out, "Reprime the piece". No. 2 straightens and carefully steps around and inside the wheel with the left foot first, then with the right in a turning movement keeping his back to the muzzle. Facing the left wheel and glancing over his left shoulder, he removes the failed primer with the gloved left hand and drops it on the ground. He receives the priming wire from the Gunner and carefully places it into the vent. The loop is struck a glancing blow with the gloved left palm, re-pricking the bag. He removes the priming wire and returns it to the Gunner. No. 3 moves up, taking care to remain outside the wheel, and hands the primer to No. 2 (No. 3 holds the primer by its lower end, rubber up). No. 2 grasps the primer at the juncture of the wire loop and lanyard hook with his left thumb and forefinger, so as to maintain control over it. No. 3 carefully plays out the lanyard so that no strain is placed upon the primer while No. 2 carries it and inserts it in the vent. No. 2 resumes his former position outside the wheel and reports READY. No. 3 resumes his firing position, nods to the Gunner and again pulls the lanyard on the command FIRE. This procedure is repeated 2 times before declaring a Level II misfire.

PACK CARRIAGE

In case of a misfire, the Gunner calls out, "Do not advance, the primer has failed: Thirty seconds after the last wisp of smoke from the vent, the Gunner will call out, "Reprime the piece". No. 2 straightens moves to the outside of the left wheel. Facing the left wheel he removes the failed primer with a gloved hand. He receives the priming wire from the Gunner and carefully drops it into the vent. The loop is struck a glancing blow with the gloved palm, re-pricking the bag. He removes the priming wire and returns it to the Gunner. No. 3 moves up, taking care to remain outside the wheel, and hands the primer to No. 2 (No. 3 holds the primer by its lower end, rubber up). No. 2 grasps the primer at the juncture of the wire loop and lanyard hook with his left thumb and forefinger, so as to maintain control over it. No. 3 carefully plays out the lanyard so that no strain is placed upon the primer while No. 2 carries it and inserts it in the vent. No. 2 resumes his former position and reports READY. No. 3 resumes his firing position, nods to the Gunner and again pulls the lanyard on the command FIRE. The major change is that no person on the crew tries to step inside between the wheel and the tube. The entire misfire procedure is conducted outside of the wheels. This procedure is repeated 2 times before declaring a Level II misfire.

MODEL 1841 MOUNTAIN HOWITZER COMPETENCY EXAM

Gunner

- To Your Posts (Stands at the end of the trail handspike)
- Gives all command clearly and in the proper order
- Seals Vent
- Holds priming wire along the shaft with thumb and forefinger when piercing the charge
- Sets himself in a good observation position before issuing the "Ready" command
- Eye contact with No. 3
- Waits to give the "Cease Firing" command until the sponge has been inserted
- Demonstrates ability to deal with safety issues as they arise (including misfires)
- Demonstrates full competence in all other positions

Misfire

- Moves to center wheel on the command to re-prime the piece
- Hands priming wire to #2 over the top of the wheel
- Returns to ready position when No. 2 returns the priming wire

Full Competence Approaching Full Competence
 Failed

Comments:

Cannoneer #1

- To Your Posts (even with front of wheel, facing forward, sponge rammer at 45 degree angle)
- Load (uses proper footwork, proper positioning at the muzzle)
- Sponge (Sponge reaches breach, eyes on the vent)
- Ram (uses 1 hand, thumb open, right refused, left hand properly pointed, eyes downrange)
- Ready (Steps back with left foot and drops sponge to the left, eyes downrange)
- Fire (Begins "Load" cycle immediately after gun fires)
- Cease Firing (Finishes sponging and returns to "To Your Posts" position)

Misfire

- Remains in Ready position, eyes down range

Full Competence Approaching Full Competence
 Failed

Comments:

Cannoneer # 2

- ___ To your post (even with front of wheel, facing forward)
- ___ Load (uses proper footwork, does a left about face, and goes back to ammo box)
- ___ Opens haversack for inspection of fused rounds to Gunner
- ___ Places powder end of the round in the muzzle (No hands or fingers in the muzzle)
- ___ Leaves muzzle immediately after inserting round
- ___ Ready (Steps back with right foot, hands to sides, eyes down range)
- ___ Fire (Begins "Load" cycle immediately after gun fires)
- ___ Cease Firing (Returns to "To Your Posts" position)

Misfire

- ___ Waits for command to re-prime
- ___ Re-prime (keeps back to muzzle, does not touch wheel)
- ___ Extracts primer with the left hand palm up then drops it to the ground
- ___ Takes priming wire from Gunner over the top of the wheel
- ___ Drops priming wire into vent then pushes down to re-pierce the charge
- ___ Properly takes new primer from #3
- ___ Properly re-places new primer & holds lanyard
- ___ Maintains eye contact with #3
- ___ Properly returns to position of Ready
- ___ Commands "Ready"

___ Full Competence ___ Approaching Full Competence
___ Failed

Comments:

Cannoneer # 3

- ___ To Your Post (in line with cascabel covering No. 1)
- ___ Load (Hooks lanyard to the primer)
- ___ Ready (uses proper footwork and proper safety while inserting friction primer in vent)
- ___ Extend Lanyard (eye contact maintained with the Gunner while extending lanyard)
- ___ Looks away once Gunner has stepped back into position
- ___ Fire (hand pulled in front of the body)
- ___ Cease Firing (Returns to "To Your Posts" position)

Misfire

- ___ Moves to center wheel on the command to re-prime the piece
- ___ Passes primer attached to lanyard to #2 over the top of the wheel
- ___ Extends lanyard while maintaining eye contact with #2
- ___ Looks away from the gun after No. 2 has cleared the wheel

___ Full Competence ___ Approaching Full
Competence ___ Failed

Comments:

APPENDIX D - DRILL FOR THE 30-POUNDER PARROTT, ADAPTED FROM THE MANUAL FOR HEAVY ARTILLERY, NEW YORK: 1862

Drill for the 30-Pounder Parrott, adapted from the *Manual for Heavy Artillery*, New York: 1862¹

	<i>Gunner</i>	<i>Cannoneer #1</i>	<i>Cannoneer #2</i>	<i>Cannoneer #3</i>	<i>Cannoneer #4</i>	<i>Cannoneer #5</i>
“Cannoneers, To Your Posts”	Post: at the end of the trail, facing forward	Post: two feet outside the right wheel, in line with the front of the wheel, facing forward	Post: two feet outside the left wheel, in line with the front of the wheel, facing forward	Post: two feet outside the right wheel, in line with the knob, facing forward	Post: two feet outside the left wheel, in line with the knob, facing forward	Post: end of the trail, covering #3, facing forward
“Take Implements”	Steps to knob; equips himself with gunner’s pouch; wears finger stall on index finger of left hand; hands tube pouch to #3; levels piece with elevating screw	Hands two handspikes to #3; takes third handspike & faces piece ² ; places handspike on platform parallel to piece, small end pointing forward	Hands one handspike to #4; takes second handspike & faces piece; places handspike on platform parallel to piece (in unison with #1)	Hands one handspike to #5; takes second handspike & faces piece; places handspike on platform parallel to piece (in unison with #1); equips himself with tube pouch	Takes handspike & faces piece; places handspike on platform parallel to piece (in unison with #1)	Takes handspike & faces piece; places handspike parallel to piece (in unison with #1)
“With Blank Charge, Load” (Sponge)	Places himself on the left side of stock, left foot forward; closes vent securely with fingerstall	Turns around & steps over sponge; takes sponge with back of hands down (left hand 1½ feet from sponge—right hand 3 feet from sponge); carries sponge forward, places inside muzzle; body erect behind muzzle, left leg straight, right knee bent, right arm extended, left hand against thigh; “One” inserts sponge as far as hand will go; “Two” slides hand along staff fully extending arm; “Three” inserts sponge as far as hand will go;	Steps to muzzle & takes position opposite #1; seizes staff with left hand, back down, near to & outside hand of #1, arm fully extended; “One” inserts sponge as far as hand will go; “Two” slides hand along staff fully extending arm; “Three” inserts sponge as far as hand will go; “Four” slides hand along staff fully extending arm; “Five” pushes sponge to bottom of bore; place both hands on staff & turn sponge 3x to left & 3x to	Embars under the breech, maintaining a convenient position for inserting the sponge	Faces to the rear & retreats to the ammunition chest; receives pass box; returns to the front of piece, facing the piece, standing 18 inches to the rear & right of #2	Faces to the rear & retreats to the ammunition chest; opens lid & places cartridge inside pass box; seals pass box & presents to #2; waits, then returns to post with #4, facing piece & recovers handspike (in unison with #1)

¹ The 4.2-inch (30-Pounder) Army Parrott rifle was mounted on the 18-pdr siege carriage.

² Handspike is held in both hands, small end toward the front of piece & at the height of shoulder, backs of the hands down, butt of hand-spike on platform.

	<i>Gunner</i>	<i>Cannoneer #1</i>	<i>Cannoneer #2</i>	<i>Cannoneer #3</i>	<i>Cannoneer #4</i>	<i>Cannoneer #5</i>
		<p>“Four” slides hand along staff fully extending arm; “Five” pushes sponge to bottom of bore; places both hands on staff & turns sponge 3x to left & 3x to right; drops left hand to side; withdraws sponge opposite to way inserted (in five motions); grasps staff with both hands & returns to prop; takes rammer in same fashion as sponge & returns to muzzle</p>	<p>right; drops right hand to side; withdraws sponge opposite to way inserted (in five motions)</p>			
(Ram Charge)	<p>Continues to close vent until #1 completes ramming & steps away from piece</p>	<p>Places head of rammer inside muzzle; right arm outstretched grasping rammer (palm up); left arm outstretched toward right trunnion; head facing forward. Charge rammed using a series of short lateral steps to the rear of the piece. Rammer withdrawn in similar fashion & returned to prop; returns to post; recovers handspike</p>	<p>Turns to #4 & receives cartridge with both hands, backs down; places cartridges inside muzzle; steps back to post two feet outside the left wheel facing piece; recovers handspike (in unison with #1)</p>		<p>Sets down pass box; takes out cartridge & presents to #2 with both hands; retreats to chest with pass box; returns to post with #5, facing piece & recovers handspike (in unison with #1)</p>	
(Ram Shell) ³						
“Unbar”	<p>Steps away from piece</p>			<p>Removes handspike from breech & returns to post facing piece</p>		

³ For safety reasons this step is not performed during live demonstrations. Historically the powder charge and projectile were loaded separately—the charge rammed first followed by the projectile.

	<i>Gunner</i>	<i>Cannoneer #1</i>	<i>Cannoneer #2</i>	<i>Cannoneer #3</i>	<i>Cannoneer #4</i>	<i>Cannoneer #5</i>
“In Battery” “Heave”		Embars through the front spokes of the wheels; heaves	Embars through the front spokes of the wheels; heaves	Embars under the rear of the wheels; heaves	Embars under the rear of the wheels; heaves	Embars under the maneuvering bolts; heaves
“Halt”	Removes priming wire ⁴	Unbars & places handspike on platform parallel to piece; resumes post facing forward	Unbars & places handspike on platform parallel to piece; resumes post facing forward	Unbars & places handspike on platform parallel to piece; resumes post facing forward	Unbars & places handspike on platform parallel to piece; resumes post facing forward	Continues to embar under the maneuvering bolts
(Aim)	Places himself at the stock; signals #5 when aim complete			Hooks friction primer to lanyard while facing forward		Points trail left or right; unbars & places handspike on platform parallel to piece; moves to safe position behind piece (in unison with gunner)
“Ready”	Moves to safe position behind the piece (in unison with #5)	Breaks away with left knee; head facing forward	Breaks away with right knee; head facing forward	Inserts friction primer in vent with left hand; handle in right hand; uncoils lanyard while carefully stepping away with back to piece; when ready turn head away from the piece		
“Fire”	Waits for #4 to uncoil lanyard & face away from piece; then commands “fire”			Pulls lanyard with quick downward motion with right hand behind back		

⁴ To ensure that the charge is not inadvertently jostled forward, the priming wire is kept in the vent until after the weapon is “maneuvered.” Any efforts to maneuver the weapon should be a simulation only—crew should be careful to only *simulate* moving the weapon.

BIBLIOGRAPHY

Gibbon, John, *The Artillerist Manual*, 2nd edition, D. VanNostrand, New York, 1863. Reprinted by the Bohemian Brigade Bookshop and Publishers, Knoxville, 2000.

Scott, H. L., *Military Dictionary*, D. Van Nostrand, New York, 1864

U.S. Army, *Instructions for Field Artillery, Horse and Foot*, compiled by a Board of Artillery Officers, Joseph Robinson, Baltimore, 1845.

U.S. Army, *The Ordnance Manual for the Use of the Officers of the United States Army*, 3rd edition, J. B. Lippincott and Co., Philadelphia, 1861.

U.S. Army, *Instruction for Field Artillery*, prepared by a Board of Artillery Officers, J.B. Lippincott and Co., Philadelphia, 1861. Reprinted by Greenwood Press, Westport, 1968.

U.S. Army, *Instruction for Field Artillery*, prepared by a Board of Artillery Officers. D. Van Nostrand, New York. Reprinted by Stackpole Books, Mechanicsburg, PA, 2005.