

FCC PART 15B MEASUREMENT AND TEST REPORT

For

ZTE Corporation

ZTE Plaza, Hi-tech Park, Nanshan District, Shenzhen,

Guangdong, China 518057

FCC ID: Q78- ZTEAC570
Model: ZTE AC570

This Report Concerns: <input checked="" type="checkbox"/> Original Report	Product Type: CDMA2000 1x EVDO USB Modem
Test Engineer: Guan bin Bob Xiong	<i>Guan bin</i> <i>Bob Xiong</i>
Report No.:	ZTER0805025-15B
Report Date:	2008-08-11
Reviewed By: David Gong Lab Manager	<i>David Gong</i>
Prepared By:	ZTE Corporation Reliability Testing Center ZTE Plaza, Keji Road South, Hi-Tech Industrial Park, NanShan District, Shenzhen, Guangdong 518057, P.R. of China Tel: +86-755-26770345 Fax: +86-755-26770347

TABLE OF CONTENTS

1 GENERAL INFORMATION.....3

1.1 PRODUCT DESCRIPTION FOR EQUIPMENT UNDER TEST (EUT)3

1.2 EUT PHOTO (PICTURE OF PRODUCT)3

1.3 OBJECTIVE3

1.4 RELATED SUBMITTAL(S)/GRANT(S).....4

1.5 TEST METHODOLOGY4

1.6 TEST FACILITY4

2 SYSTEM TEST CONFIGURATION5

2.1 JUSTIFICATION5

2.2 EQUIPMENT MODIFICATIONS5

2.3 LOCAL SUPPORT EQUIPMENT LIST AND DETAILS5

2.4 TEST SETUP BLOCK DIAGRAM.....5

3 SUMMARY OF TEST RESULTS6

4 §15.107 – CONDUCTED EMISSION7

4.1 APPLICABLE STANDARD7

4.2 EUT SETUP7

4.3 TEST EQUIPMENT LIST AND DETAILS.....7

4.4 TEST PROCEDURE8

4.5 ENVIRONMENTAL CONDITIONS8

4.6 SUMMARY OF TEST RESULTS8

4.7 CONDUCTED EMISSIONS TEST PLOTS AND DATA.....8

5 §15.109 –RADIATED EMISSION11

5.1 APPLICABLE STANDARD11

5.2 TEST SETUP11

5.3 TEST EQUIPMENT LIST AND DETAILS.....11

5.4 TEST PROCEDURE12

5.5 ENVIRONMENTAL CONDITIONS12

5.6 CORRECTED AMPLITUDE & MARGIN CALCULATION12

5.7 SUMMARY OF TEST RESULTS – 30 MHZ TO 1 GHZ.....13

EXHIBIT A - FCC ID LABEL INFORMATION18

FCC ID LABEL18

FCC ID LABEL LOCATION18

EXHIBIT B - TEST SETUP PHOTOGRAPHS19

CONDUCTED TEST SETUP.....19

RADIATED SETUP.....20

EXHIBIT C - EUT PHOTOGRAPHS.....22

EUT FRONT VIEW.....22

EUT REAR VIEW22

EUT REAR OFF VIEW.....23

EUT COVER OFF VIEW.....23

EUT COVER OFF VIEW.....24

1 GENERAL INFORMATION

1.1 Product Description for Equipment Under Test (EUT)

The ZTE Corporation's product, FCC ID: Q78-ZTEAC570 or the "EUT" as referred to in this report is a EVDO USB Modem, which measures approximately 90.4mm (L) x 35mm (W) x 12.3mm (H)

The frequency ranges are

CDMA 800MHz Cellular (UL824MHz ~ 849 MHz, DL 869 MHz ~ 894 MHz)
CDMA 1900MHz PCS (UL1850 MHz ~1910 MHz, DL1930 MHz ~1990 MHz)

* The test data gathered are from production sample, serial number: 290727810211, provided by the manufacturer.

1.2 EUT Photo (picture of product)



Additional Photos in Exhibit C

1.3 Objective

This report has been prepared by ZTE Corp. in accordance with Part 2, Subpart J, and Part 15, Subparts A and B of the Federal Communications Commission rules, and Canadian ICES-003, Interference – Causing Equipment Standards for Digital Apparatus.

The objective is to determine compliance with FCC Part 15 Standard, Class B limits, and Canadian ICES-003 Standard, Class B limits for conducted and radiated emission requirements for the digital device portion of this device. For all measurement and tests pertaining to the intentional radiator please see ZTE report ZTER0805025.

1.4 Related Submittal(s)/Grant(s)

Part22H & 24E: FCC ID: Q78-ZTEAC570

1.5 Test Methodology

All measurements contained in this report were conducted in accordance with ANSI C63.4-2003, American National Standard for Methods of Measurement of Radio-Noise Emissions from Low-Voltage Electrical and Electronic Equipment in the range of 9 kHz to 40 GHz. All radiated and conducted emissions measurements were performed at ZTE Corporation Reliability Testing Center

1.6 Test Facility

ZTE Corporation Reliability Testing Center
ZTE Plaza, Keji Road South, Hi-Tech Industrial Park, NanShan District, Shenzhen, Guangdong, 518057
, P.R. of China

Tel: +86-755-26770345

Fax: +86-755-26770347

Test site at ZTE Corporation has been fully described in reports submitted to the Federal Communication Commission (FCC).

The details of these reports have been found to be in compliance with the requirements of Section 2.948 of the FCC Rules on December 25, 2005. ZTE Corporation Lab's FCC Registration Number is 373926.

2 SYSTEM TEST CONFIGURATION

2.1 Justification

The EUT was configured for testing according to ANSI C63.4-2003.

The final qualification test was performed with the EUT operating at normal mode.

2.2 Equipment Modifications

No modifications were made to the EUT.

2.3 Local Support Equipment List and Details

Manufacturer	Description	Model	Serial Number
Agilent	Wireless communication test set	8960 E5515C	GB42431673
HP	Laptop	NC8430 (AC Adaptor: PPP012L-S)	CNU64610SB

2.4 Test Setup Block Diagram

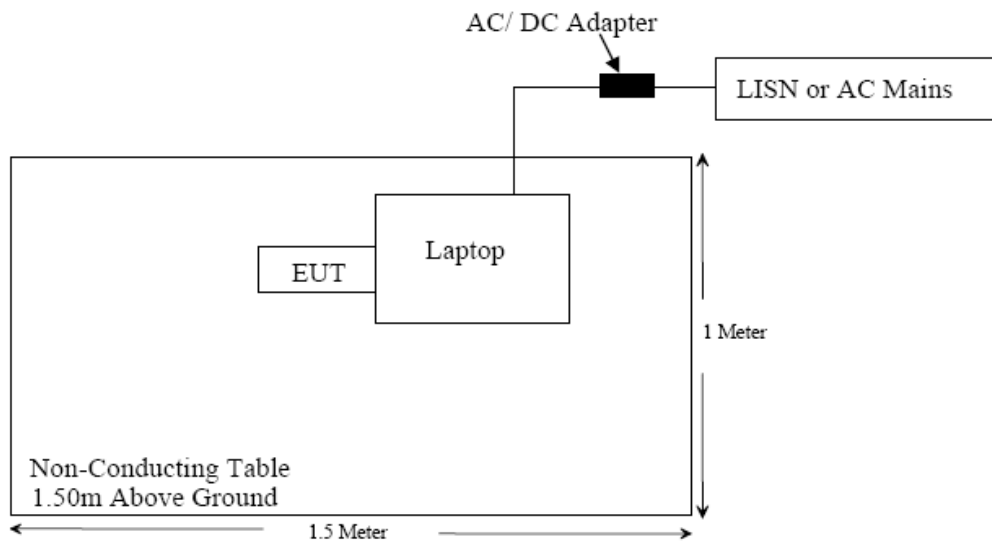

3 SUMMARY OF TEST RESULTS

FCC Rules	Description of Test	Result
§ 15.107	Conducted Emission at AC	Compliant
§ 15.109	Radiated Emission	Compliant

4 §15.107 – Conducted Emission

4.1 Applicable Standard

As per FCC §15.107: Conducted Limits

(a) Except for Class A digital devices, for equipment that is designed to be connected to the public utility (AC) power line, the radio frequency voltage that is conducted back onto the AC power line on any frequency or frequencies within the band 150 kHz to 30 MHz shall not exceed the limits in the following table, as measured using a 50 μH/50 ohms line impedance stabilization network (LISN). Compliance with the provisions of this paragraph shall be based on the measurement of the radio frequency voltage between each power line and ground at the power terminal. The lower limit applies at the band edges.

Frequency of Emission (MHz)	Conducted Limit (dBμV)	
	Quasi-Peak	Average
0.15 – 0.5	66 to 56 *	56 to 46 *
0.5 – 5	56	46
5 – 30	60	50

* Decreases with the logarithm of the frequency.

4.2 EUT Setup

The conducted emissions tests were performed in the 10-meter test chamber, using the setup in accordance with ANSI C63.4-2003 measurement procedures. The specifications used were in accordance with FCC Part 15 Standard, Class B limits.

The spacing between the peripherals was 10 cm.

The external I/O cables were draped along the test table and bundled as required.

The EUT was connected a laptop computer which via AC/DC adapter was connected to a LISN that provided 120 V/ 60 Hz power.

4.3 Test Equipment List and Details

Manufacturer	Description	Model	Serial Number	Cal. Date
R&S	EMI Test Receiver 20Hz~26.5GHz	ESI26	100058	2007-10-25
EMCO	LISN	ESH2-Z5	871884	2007-10-12

Statement of Traceability: ZTE Corporation Reliability Testing Center attests that all calibrations have been performed per the NVLAP requirements, traceable to the NIST.

4.4 Test Procedure

During the conducted emissions test, the power cord of the host system was connected to the main outlet of the LISN-1.

Maximizing procedure was performed on the six (6) highest emission readings from the EUT.

All data was recorded in the peak detection mode, quasi-peak and average. Average readings are labeled “AV,” and Quasi-peak readings are labeled “QP,” in the test data hereinafter.

4.5 Environmental Conditions

Temperature:	22° C
Relative Humidity:	55%
ATM Pressure:	1018mbar

* The testing was performed by Guan Bin on 2008-04-10

4.6 Summary of Test Results

According to the recorded data, the EUT complied with FCC §15.107 Standard, Class B limits, and had the worst margin reading of:

Conducted Disturbance at AC port			
Margin (dB)	Frequency (MHz)	Conductor Mode (Hot/Neutral)	Range (MHz)
2.9	0.46795	Neutral	0.150 to 30

4.7 Conducted Emissions Test Plots and Data

Please refer to the following plots and tables.

Conducted Disturbance at AC port measurements were undertaken on the HOT

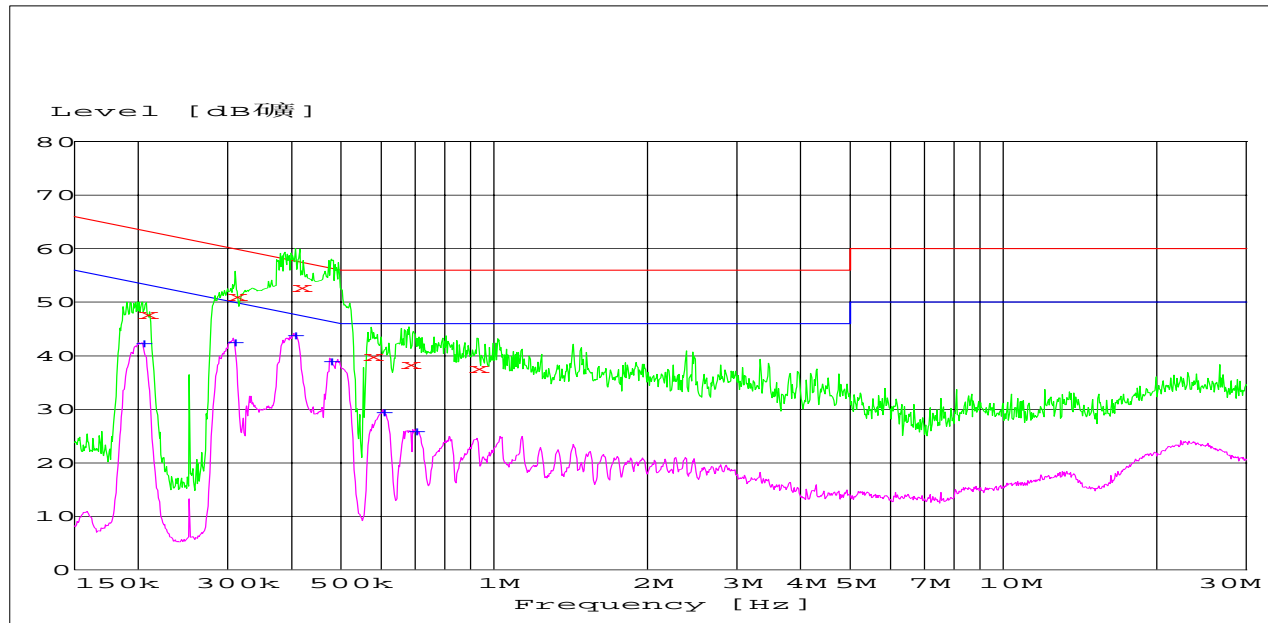

Quasi-Peak Measurements

Frequency (MHz)	Quasi-Peak (dBµV)	Conductor (Hot/Neutral)	Transd. (dB)	Limit (dBµV)	Margin (dB)
0.415134	52.9	HOT	9.9	58	4.7
0.310189	51.2	HOT	9.9	60	8.8
0.207263	47.9	HOT	9.9	63	15.4
0.573613	40	HOT	9.9	56	16
0.681033	38.4	HOT	9.9	56	17.6
0.926114	37.7	HOT	9.9	56	18.3

Average Measurements

Frequency (MHz)	Average (dBµV)	Conductor (Hot/Neutral)	Transd. (dB)	Limit (dBµV)	Margin (dB)
0.403694	43.8	HOT	9.9	48	4
0.475482	39.1	HOT	9.9	46	7.3
0.307723	42.6	HOT	9.9	50	7.4
0.203167	42.3	HOT	9.9	54	11.2
0.604167	29.6	HOT	9.9	46	16.4
0.697543	25.9	HOT	9.9	46	20.1

Conducted Disturbance at AC port measurements were undertaken on the Neutral

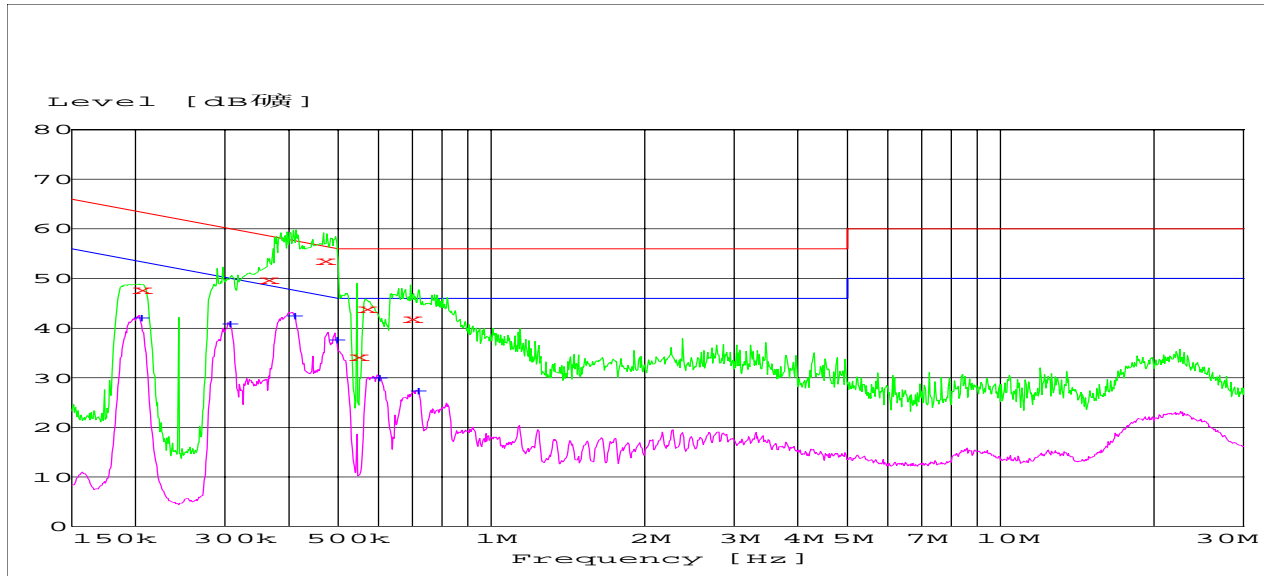

Quasi-Peak Measurements

Frequency (MHz)	Quasi-Peak (dBµV)	Conductor (Hot/Neutral)	Transd. (dB)	Limit (dBµV)	Margin (dB)
0.46795	53.7	Neutral	9.9	57	2.9
0.362445	49.8	Neutral	9.9	59	8.9
0.564526	44	Neutral	9.9	56	12
0.694763	41.9	Neutral	9.9	56	14.1
0.204796	47.9	Neutral	9.9	63	15.5
0.544604	34.3	Neutral	9.8	56	21.7

Average Measurements

Frequency (MHz)	Average (dBµV)	Conductor (Hot/Neutral)	Transd. (dB)	Limit (dBµV)	Margin (dB)
0.40693	42.6	Neutral	9.9	48	5.1
0.492876	37.7	Neutral	9.9	46	8.4
0.304059	41	Neutral	9.9	50	9.2
0.203167	42.1	Neutral	9.9	54	11.4
0.596975	30.1	Neutral	9.8	46	15.9
0.711605	27.4	Neutral	9.9	46	18.6

5 §15.109 –Radiated Emission

5.1 Applicable Standard

As per FCC §15.109: Radiated Emission Limits

(a) Except for Class A digital devices, the field strength of radiated emissions from unintentional radiators at a distance of 3 meters shall not exceed the following values:

Frequency of Emission (MHz)	Field Strength ($\mu\text{V/m}$)
30 – 88	100
88 – 216	150
216 – 960	200
Above 960	500

(g) As an alternative to the radiated emission limits shown in paragraphs (a) and (b) of this section, digital devices may be shown to comply with the standards contained in Third Edition of the International Special Committee on Radio Interference (CISPR), Pub. 22, “Information Technology Equipment – Radio Disturbance Characteristics – Limits and Methods of Measurement.”

Note: The CISPR 22 §6 Standard, Class B limits are applied to the test data hereinafter.

5.2 Test Setup

The radiated emissions tests were performed in the 10-meter test chamber, using the setup in accordance with ANSI C63.4-2003 measurement procedures. The specifications used were in accordance with CISPR 22 Standard, Class B limits for frequencies between 30 MHz and 1 GHz, and FCC Part 15 Standard, Class B limits for frequencies above 1 GHz.

The spacing between the peripherals was 10 cm.

The external I/O cables were draped along the test table and bundled as required. The EUT was connected to a laptop which was connected to the AC Mains to represent normal operating conditions.

5.3 Test Equipment List and Details

Manufacturer	Description	Model	Serial Number	Cal. Date
R & S	EMI Test Receiver 20Hz~26.5GHz	ESI26	100058	2007-10-25
R & S	Log periodic Antenna 30~3000MHz	HL562	100022	2008-03-07
R & S	Cable Set Up to 18Ghz	RF Cable	N/A	2007-10-25
Albatross	Anechoic Chamber 3m site	3m site	N/A	2007-5-14
R&S	Software	ES-K1	N/A	N/A
Agilent	Universal radio communication tester	8960	GB42431673	2008-01-18

* Statement of Traceability: ZTE Corporation Reliability Testing Center attests that all calibrations have been performed per the NVLAP requirements, traceable to the NIST.

5.4 Test Procedure

The test site semi-anechoic chamber has met the requirement of NSA tolerance 4dB according to the standards: ANSI C63.4 (2003). The test distance was 3m. The EUT was set-up on insulator 0.8m above the Metallic Turntable

The radiated disturbance measurements were made using a Rohde and Schwarz ESI Test Receiver and control software ES-K1.

A preliminary scan and a final scan of the emissions were made from 30MHz to 1GHz by using test script of software; the emissions were measurement using a Quasi-Peak detector. The maximal emission value was acquired by adjusting the antenna height, polarization and turntable azimuth in accordance with the software setup. Normally, the height range of antenna was 1m to 4m, the azimuth range of turntable was 0° to 360°. The receive antenna has two polarizations V and H.

The EUT was communicated with the Universal radio communication tester through Air interface, Measurement bandwidth (RBW) for 30MHz to 1000 MHz: 120 kHz.

5.5 Environmental Conditions

Temperature:	22.5° C
Relative Humidity:	57%
ATM Pressure:	1016mbar

* The testing was performed by Guan Bin on 2008-08-11

5.6 Corrected Amplitude & Margin Calculation

The Corrected Amplitude is calculated by adding the Antenna Factor, and Cable Factor, and subtracting the Amplifier Gain from the Amplitude reading. The basic equation is as follows:

$$\text{Corrected Amplitude} = \text{Indicated Reading} + \text{Antenna Factor} + \text{Cable Factor} - \text{Amplifier Gain}$$

The "Margin" column of the following data tables indicates the degree of compliance within the applicable limit. For example, a margin of -7 dB means the emission is 7 dB below the maximum limit for Class B. The equation for margin calculation is as follows:

$$\text{Margin} = \text{Corrected Amplitude} - \text{Class B Limit}$$

5.7 Summary of Test Results – 30 MHz to 1 GHz

According to the recorded data, the EUT complied with FCC §15.109 Standard, Class B limits, and had the worst margin readings of:

Unintentional radiation

800 MHz			
Mode: No transmission Mode(Idle)			
Margin (dB)	Frequency (MHz)	Polarization (Horizontal/Vertical)	Range (MHz)
4.4	661.76	Vertical	30 to 1000

1900 MHz			
Mode: No transmission Mode(Idle)			
Margin (dB)	Frequency (MHz)	Polarization (Horizontal/Vertical)	Range (MHz)
4.88	364.34	Horizontal	30 to 1000

Radiated Emissions Test Plots and Data

No transmission Mode (Idle)

800 MHz Horizontal

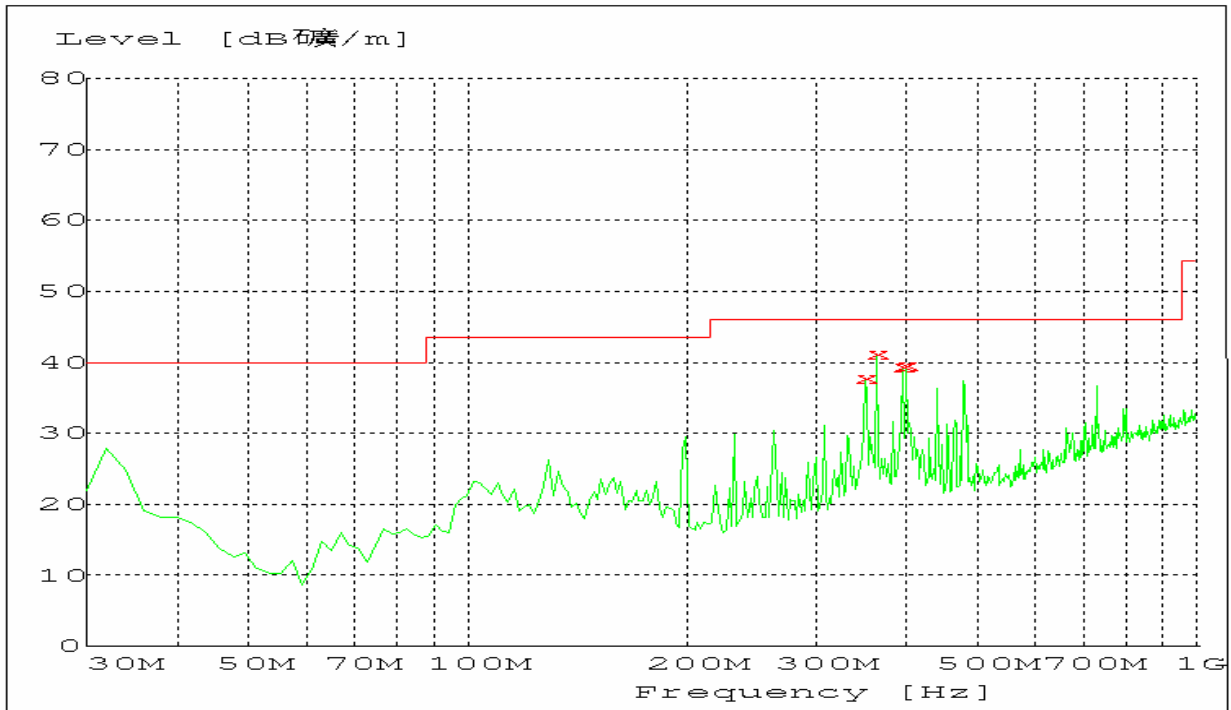

Measurement Results: Quasi-Peak Detector

Frequency (MHz)	Quasi-Peak (dBμV/m)	Turntable Position (degrees)	Antenna Height (cm)	Ant. Polarity (H/V)	Transd. (dB)	Limit (dBμV/m)	Margin (dB)
350.74	37.66	246	100	H	-14.7	46	8.34
364.34	41.12	354	100	H	-14.3	46	4.88
395.45	39.36	136	100	H	-13.2	46	6.64

800 MHz Vertical

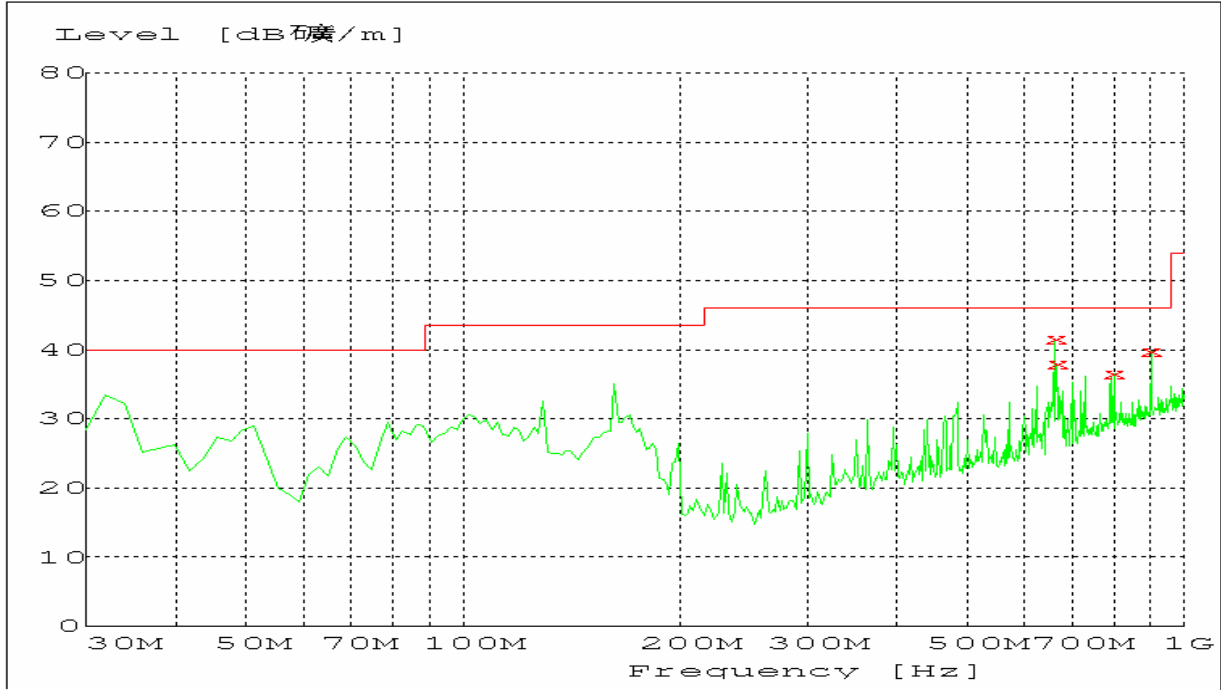

Measurement Results: Quasi-Peak Detector

Frequency (MHz)	Quasi-Peak (dBµV/m)	Turntable Position (degrees)	Antenna Height (cm)	Ant. Polarity (H/V)	Transd. (dB)	Limit (dBµV/m)	Margin (dB)
661.76	41.60	83.00	100.0	V	-7.5	46	4.4
665.65	37.93	193.00	100.0	V	-7.6	46	8.07
799.78	36.50	30.00	100.0	V	-4.9	46	9.5
900.86	39.77	248.00	100.0	V	-3.4	46	6.23

1900MHz Horizontal

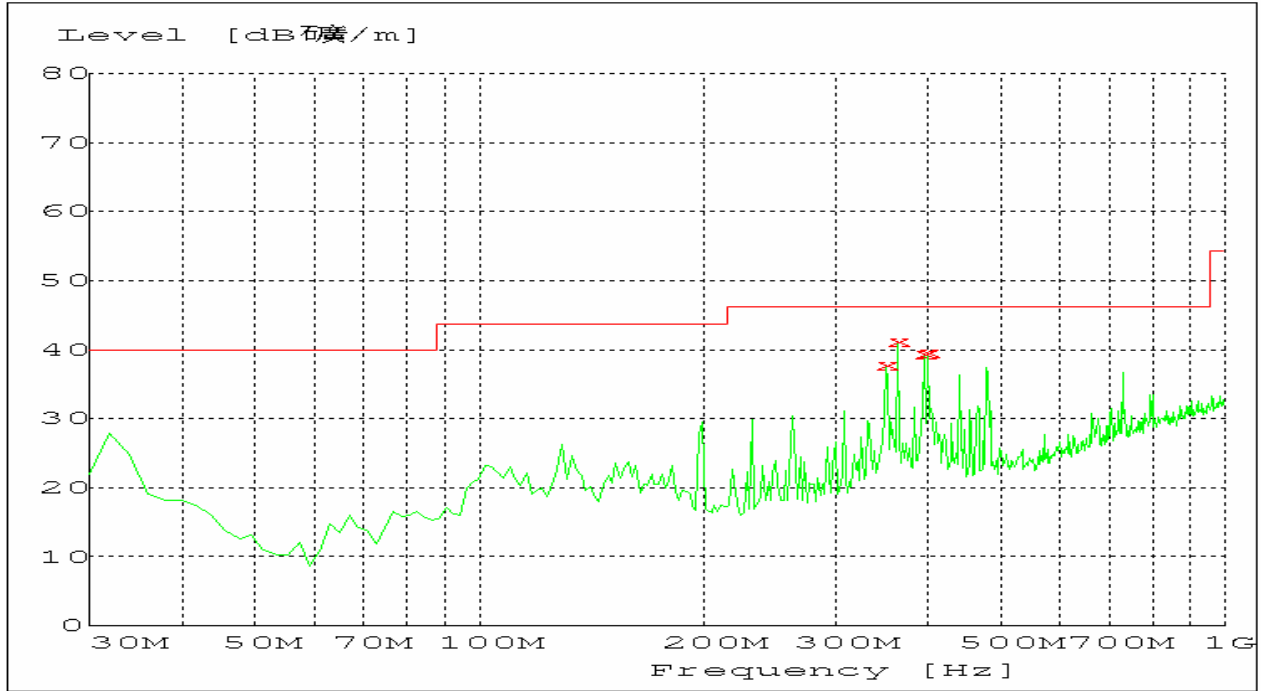

Measurement Results: Quasi-Peak Detector

Frequency (MHz)	Quasi-Peak (dBµV/m)	Turntable Position (degrees)	Antenna Height (cm)	Ant. Polarity (H/V)	Transd. (dB)	Limit (dBµV/m)	Margin (dB)
350.74	37.66	246	100	H	-14.7	46	8.34
364.34	41.12	354	100	H	-14.3	46	4.88
395.45	39.36	136	100	H	-13.2	46	6.64
399.33	39.64	354.00	100.0	H	-13.2	46	6.36

1900MHz (30MHz~3GHz) Vertical

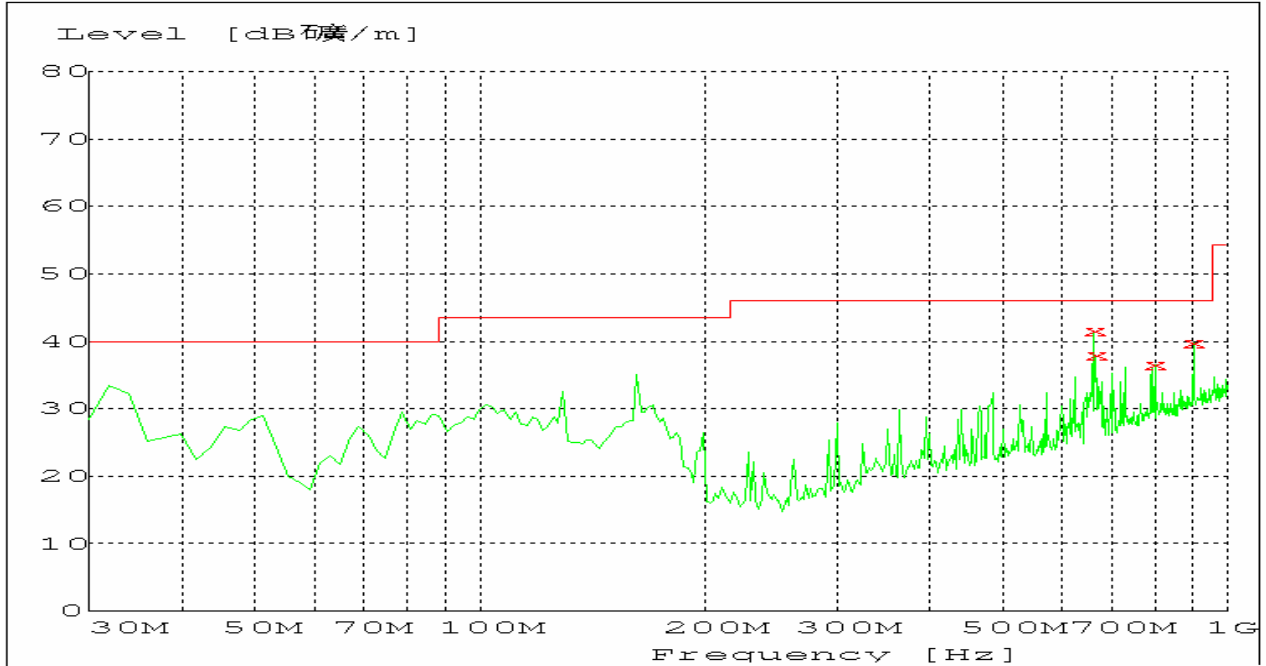

Measurement Results: Quasi-Peak Detector

Frequency (MHz)	Quasi-Peak (dBμV/m)	Turntable Position (degrees)	Antenna Height (cm)	Ant. Polarity (H/V)	Transd. (dB)	Limit (dBμV/m)	Margin (dB)
665.65	37.93	193.00	100.0	V	-7.6	46	8.07
799.78	36.50	30.00	100.0	V	-4.9	46	9.5
900.86	39.77	248.00	100.0	V	-3.4	46	6.23