

primary locomotive under remote control. The isolation doors in the turnout would be closed, allowing the locomotive operators to recouple the secondary locomotive to the railcar. The empty transporter would be returned to the Waste Handling Building to pick up the next waste package (DIRS 153849-DOE 2001, Section 2.3.4.4.1).

DOE has developed plans for waste package retrieval for normal and off-normal conditions. Waste package retrieval under normal conditions would use the same subsurface equipment and facilities as emplacement, but in reverse order. This would provide a built-in capability for retrieval that could be readily implemented. Individual waste package removal for inspection, testing, and maintenance reasons is not considered retrieval; however, waste package removal for these purposes, if needed, would involve the same equipment and operational steps. Alternative waste package retrieval equipment and processes have been identified for off-normal conditions when normal retrieval procedures could be difficult or impossible to execute. Additionally, support equipment (equipment to remove obstacles, prepare surfaces, or install temporary ground supports) that could be used in retrieval operations under off-normal conditions has been identified. The equipment and processes would support various scenarios such as repair of the raiing system, repositioning the emplacement pallet and waste package, or cleaning or removal of debris. All retrieval scenarios include radiation and temperature controls and other administrative controls, as needed, to conduct a safe retrieval operation (see DIRS 153849-DOE 2001, Section 2.3.4.6).

2.1.2.2.4 Engineered Barrier Design

Engineered barriers would include those components in the emplacement drifts that would contribute to waste containment and isolation. The design includes the following components as engineered barriers: (1) waste package, (2) emplacement drift *invert*, (3) *drip shield*, and (4) to a lesser extent, ground support (DIRS 153849-DOE 2001, Section 2.4). The following sections describe the details of these components.

2.1.2.2.4.1 Waste Package and Drip Shields. The function of the waste package would change over time. During the operation and monitoring phase, the waste packages would function as the vessels for safely handling, emplacing and, if necessary, retrieving their contents. After closure, the waste packages would be the primary engineered barrier to inhibit the release of radioactive material to the environment. The waste package design consists of two closed concentric cylinders in which DOE would place the waste forms.

The waste package would have a corrosion-resistant *Alloy-22* outer shell and a stainless-steel (Type 316NG) inner shell to provide structural support (DIRS 153849-DOE 2001, Section 3). *Alloy-22* consists mostly of nickel, chromium (up to 22.5 percent), and molybdenum (up to 14.5 percent). Type 316NG stainless steel consists mostly of iron, chromium (up to 18 percent), nickel (up to 14 percent), and molybdenum (up to 3 percent) (DIRS 153849-DOE 2001, Section 3.4.1.1). In addition, the waste package would have a top lid design that consisted of three lids. The innermost lid would be stainless steel welded to the stainless-steel shell. The middle and outer lids would be *Alloy-22*, welded to the *Alloy-22* outer shell (DIRS 153849-DOE 2001, Section 3) (see Figure 2-15). The highly corrosion-resistant *Alloy-22* outer shell of the waste package would protect the underlying structural material from corrosive degradation, while the strong internal structural material would support the thinner corrosion-resistant material.

A drip shield with a nominal thickness of 1.5 centimeters (0.6 inch) of highly corrosion-resistant titanium would be placed over the waste package just before repository closure. The titanium drip shield and the *Alloy-22* outer cylinder would provide two diverse engineered corrosion barriers to protect the waste from contact with water. The use of two distinctly different corrosion-resistant materials would reduce the *probability* that a single mechanism could cause the failure of both materials. Figure 2-16 shows a side view of a drip shield and an end view of the waste package and drip shield.

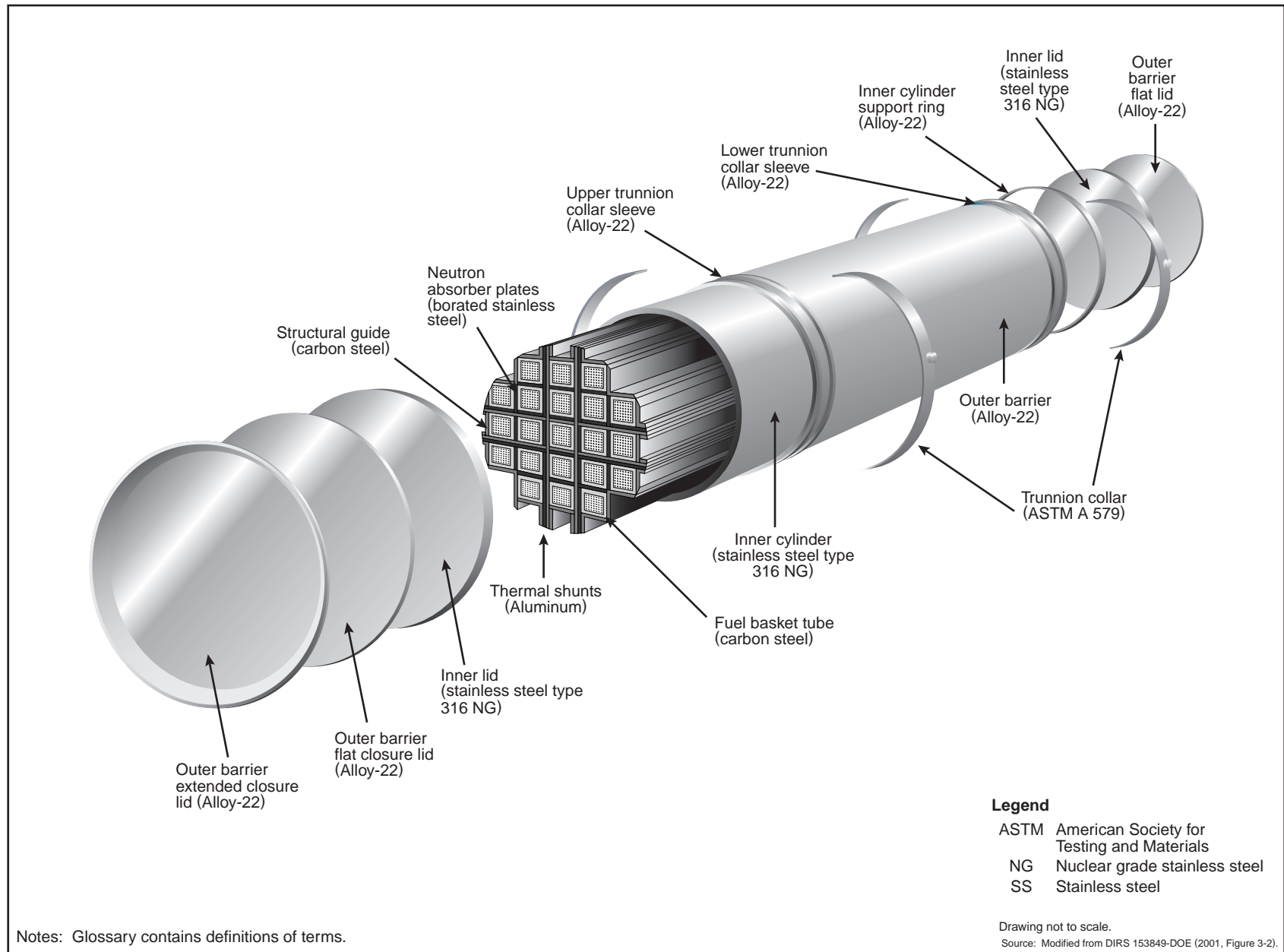
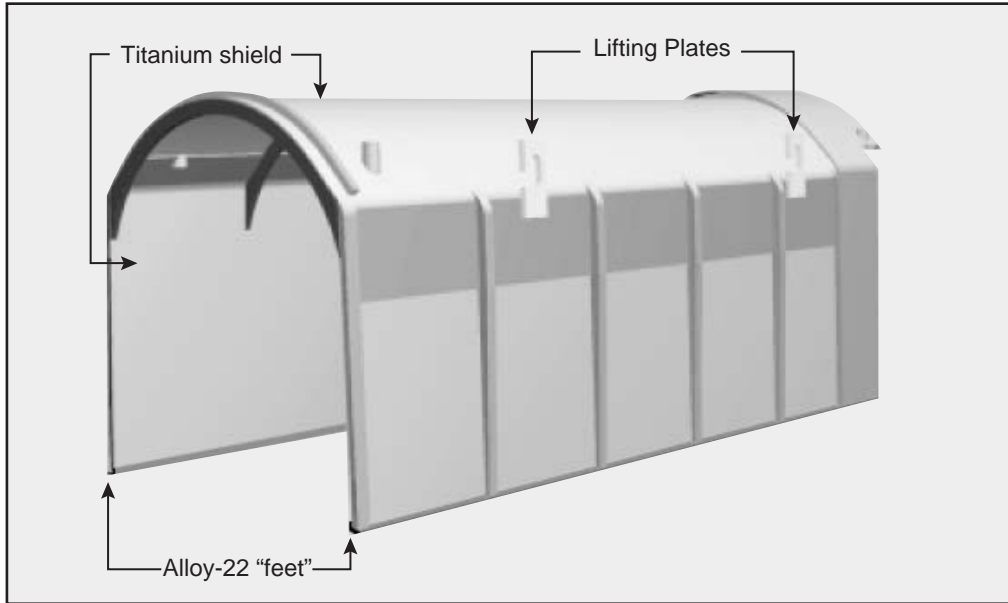
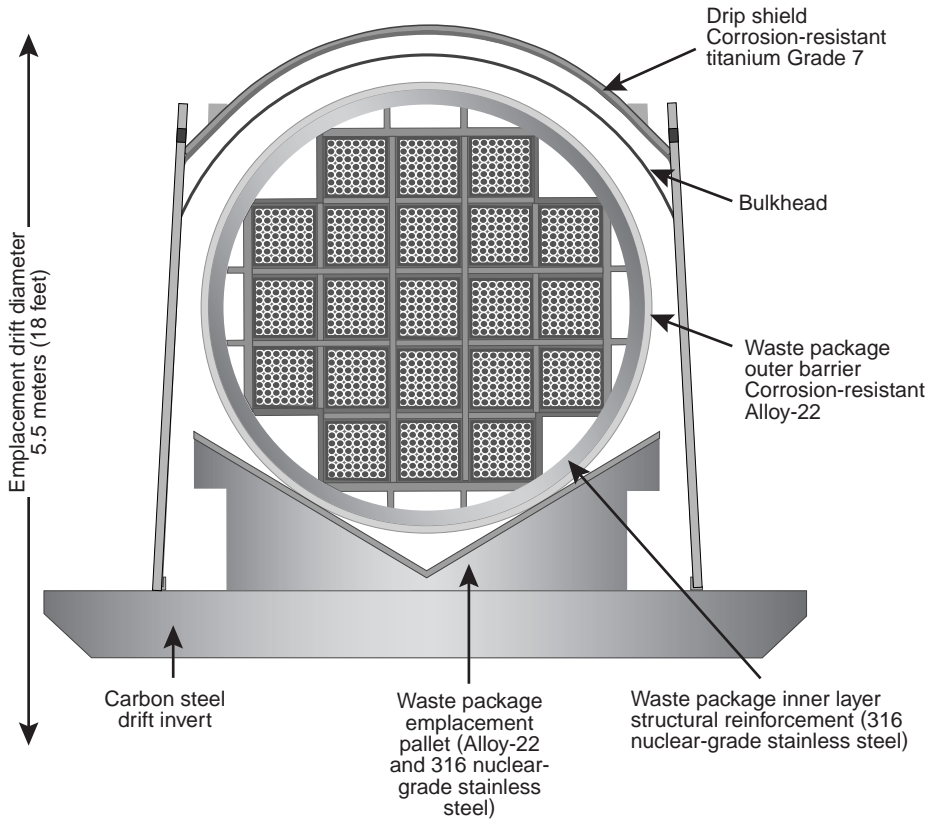

Figure 2-15. Waste package for commercial spent nuclear fuel (pressurized-water reactor waste package).



Drip shield



Drawing not to scale.

Source: Modified from DIRS 153849-DOE (2001, Figures 2-73 and 3-1).

Figure 2-16. Drip shield and waste package containing commercial spent nuclear fuel with drip shields in place.

Commercial spent nuclear fuel, DOE spent nuclear fuel, and immobilized plutonium contain *fissile material*, which is material capable, in principle, of sustaining a fission *chain reaction*. For a self-sustaining chain reaction to take place, a critical mass of fissile material—uranium-233 or -235 or one of several plutonium isotopes—must be arranged in a critical configuration. Waste packages would be loaded with fissile material and *neutron absorbers*, if needed, so *criticality* could not occur even in the unlikely event that the waste package somehow became full of water.

After the repository ventilation was stopped and heat produced by the waste packages had decreased (both of which would happen after closure), moisture could enter the emplacement drifts in liquid or vapor form. The function of the drip shields would be to divert water that dripped from the drift walls and water vapor that condensed on the surface of the drip shields away from waste packages, prolonging their longevity and structural integrity. Water dripping on the waste packages would increase the likelihood of corrosion. For the EIS analyses, the drip shields were considered to be a single continuous barrier for the entire length of the emplacement drift if the separation between the waste packages was less than 1.6 meters (5.3 feet). If the separation was greater than 1.6 meters, the EIS analyses used stand-alone drip shields. They would be strong enough to protect the waste packages from damage by rockfalls resulting from degradation of the drift walls, withstanding damage from rocks weighing several tons (DIRS 153849-DOE 2001, Section 2.4.4). To maintain waste package retrievability, the drip shields, via remote control, would be placed over the waste packages just before repository closure.

2.1.2.2.4.2 Ground Support Structures. In underground openings, ground support structures provide tunnel stability and help prevent rockfall. For the proposed repository, the ground support system would address in-place loads, construction loads, potential loads from repository operations, and loads from potential seismic occurrences (DIRS 153849-DOE 2001, Section 2.3.4.1.2). The system would consist of steel sets with welded-wire fabric and fully grouted rockbolts.

The main drifts, turnouts, exhaust main, and ventilation shafts (nonemplacement areas) would have separate initial and final ground support systems. Initial ground support methods would vary depending on ground conditions, and would include a combination of steel sets, welded-wire fabric, rockbolts, and shotcrete (concrete sprayed onto the surface at high pressure). The final ground support system for the nonemplacement drift areas would be cast-in-place concrete liners.

The observation drifts, which would support the performance confirmation program, would have a ground support system similar to that for the emplacement drifts if they were excavated with a tunnel boring machine. Otherwise, they would have a combination of support systems, including steel sets, welded-wire fabric, rockbolts, and shotcrete, depending on ground conditions (DIRS 153849-DOE 2001, Section 2.3.4.1.2.2).

2.1.2.2.4.3 Emplacement Pallets. The repository design uses emplacement pallets to support the waste packages. A waste package would be placed horizontally on its support (an emplacement pallet) in the Waste Handling Building and transported to the drifts as a unit. Figure 2-17 shows a conceptual design of spent nuclear fuel and high-level radioactive waste package types in an emplacement drift on emplacement pallets, drip shields, and steel sets for ground support. The emplacement pallet would support the waste package in the drift. While loaded with a waste package, the pallet would be lifted by lifting points at the support, directly under the upper stainless-steel tubes, as shown in Figure 2-18. The pallet design would meet the design requirements for structural strength during lifting under the weight of the heaviest waste package (DIRS 153849-DOE 2001, Section 2.3.4.4.2).

Figure 2-19 shows an emplacement pallet, and Figure 2-18 shows a waste package on an emplacement pallet. There would be two sizes of pallet: one that would hold most waste packages and a second, shorter version for the DOE codisposal waste package (DIRS 153849-DOE 2001, Section 2.3.4.4.2). The emplacement pallets would be made of Alloy-22 plates welded together to form the waste package

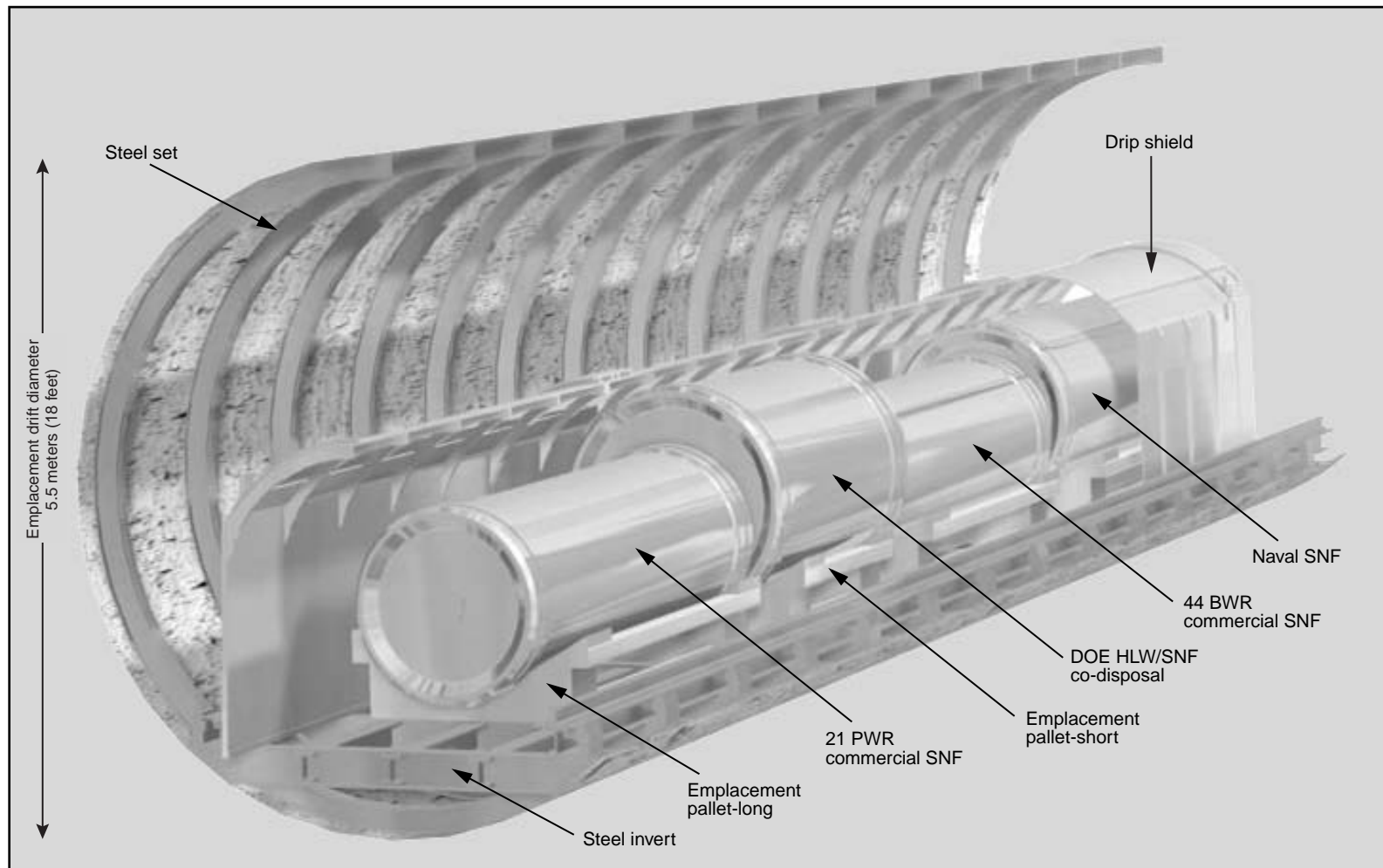

Legend

BWR	Boiling-water reactor
DOE	U.S. Department of Energy
HLW	High-level radioactive waste
PWR	Pressurized-water reactor
SNF	Spent nuclear fuel

Drawing not to scale.

Source: Modified from DIRS 153849-DOE (2001, Figure 2-77).

Figure 2-17. Typical section of emplacement drift with waste packages and drip shields in place.

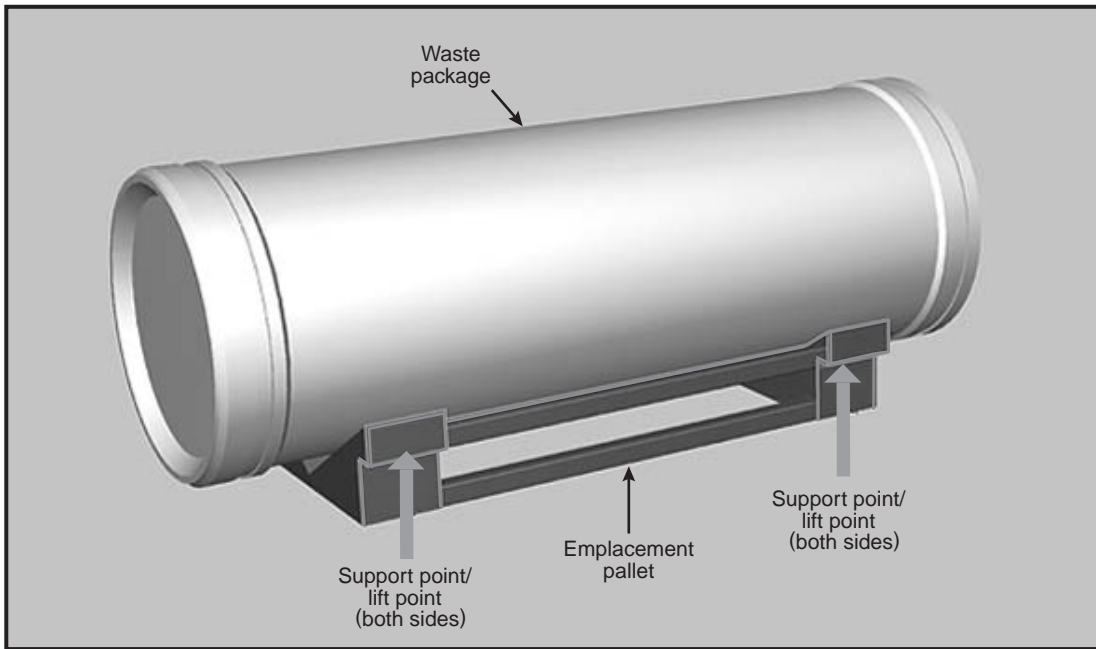

Drawing not to scale.

Source: DIRS 153849-DOE (2001, Figure 2-52).

Figure 2-18. Waste package on an emplacement pallet.

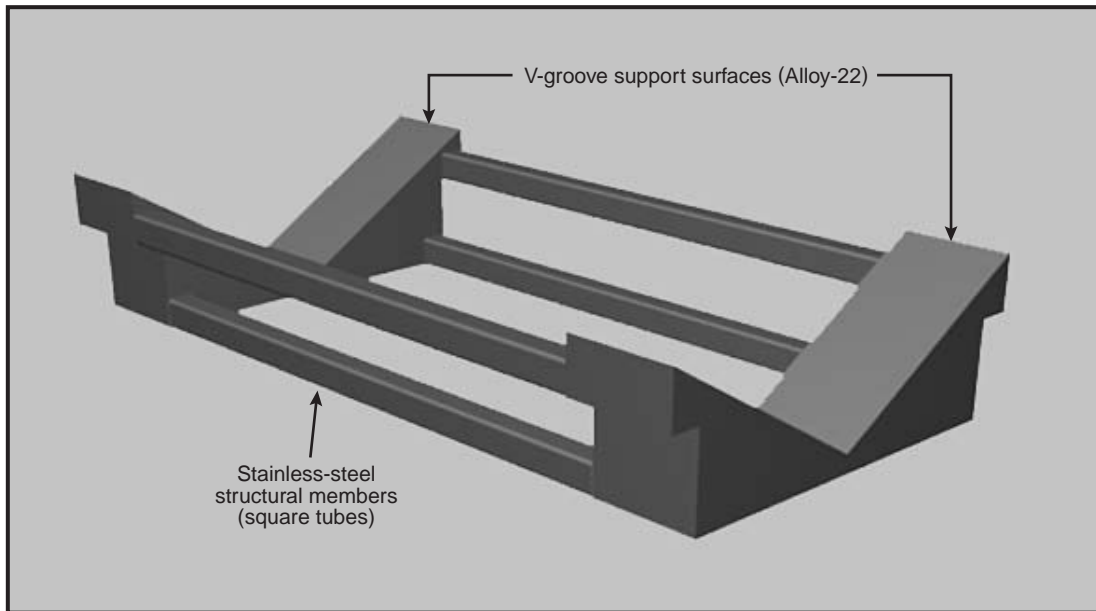

Drawing not to scale.

Source: DIRS 153849-DOE (2001, Figure 2-51).

Figure 2-19. Emplacement pallet.

supports. Two supports would be connected by square stainless-steel tubing to form the completed emplacement pallet. The supports would have a V-groove top surface to accept all waste package diameters. Emplacement pallet surfaces that contacted the waste package would be Alloy-22, the same material used for the outer package shell.

The ends of the waste package would extend past the ends of the emplacement pallet, which would allow placement of the waste packages end-to-end, within 10 centimeters (4 inches) of each other, without interference from the pallets (DIRS 153849-DOE 2001, Section 2.3.4.4.2).

2.1.2.3 Performance Confirmation Program

Performance confirmation refers to the program of tests, experiments, and analyses that DOE would conduct to evaluate the adequacy of the information used to demonstrate compliance that the repository would meet performance objectives. The performance confirmation program, which would continue through the licensing and construction phases and until the closure phase, would include elements of site testing, repository testing, repository subsurface support facilities construction, and waste package testing. Some of these activities would be a continuation of activities that began during site characterization.

To support performance confirmation activities, DOE would provide some specialized surface and subsurface facilities. DOE would build observation drifts below and above the *repository horizon* (DIRS 153849-DOE 2001, Section 2.5.2.2). The data-collection focus of the performance confirmation program would be to collect additional information to confirm the data used in the License Application. If the Nuclear Regulatory Commission granted a license, the activities would focus on monitoring and data collection for performance parameters important to terms and conditions of the license.

Performance confirmation drifts would be built about 15 meters (50 feet) above and below the emplacement drifts. DOE would drill boreholes from the performance confirmation drifts that would approach the rock mass near the emplacement drifts; instruments in these boreholes would gather data on the thermal, mechanical, hydrological, and chemical characteristics of the rock after waste emplacement. DOE would acquire performance confirmation data by sampling and mapping, from instruments in performance confirmation drifts or along the perimeter mains, ventilation exhaust monitoring, remote inspection systems in emplacement drifts, and monitoring of water quality in wells.

DOE would use the performance confirmation program data to evaluate system performance and to confirm predicted system response. If the data determined that actual conditions differed from those predicted, the Nuclear Regulatory Commission would be notified and remedial actions would be undertaken to address any such condition (DIRS 153849-DOE 2001, Sections 2.5 and 4.6).

2.1.2.4 Repository Closure

Before closure, an application to amend the Nuclear Regulatory Commission license would have to provide an update of the assessment of repository performance for the period after closure, as well as a description of the program for postclosure monitoring to regulate or prevent activities that could impair the long-term isolation of waste. The postclosure monitoring program, as required by Section 801(c) of the Energy Policy Act of 1992 and as required by the Nuclear Regulatory Commission (10 CFR Part 63), would include the monitoring activities that would be conducted around the repository after the facility had been closed and sealed. Regulations at 10 CFR 63.51(a)(1) and (2) would require the submittal of a license amendment for closure of the repository (see Section 2.3.4.8). The details of this program would be delineated during processing of the license amendment for closure. Deferring the delineation of this program to the closure period would allow identification of appropriate technology, including technology that might not be currently available (DIRS 153849-DOE 2001, Sections 2.3.4.8 and 4.6.1).