



FCC Test Report

**Product Name: WCDMA/GPRS/GSM Mobile Phone
With Bluetooth**

Model Number: U1300/Vodafone 725/V725

**Report No: SYBH(R) 028012008EB-3
FCC ID: QISU1300**

Reliability Laboratory of Huawei Technologies Co., Ltd.

Huawei Base, Bantian, Longgang District, Shenzhen 518129, P.R. China

Tel: +86 755 28780808 Fax: +86 755 89652518

Notice

1.	The laboratory has obtained the accreditation of China National Accreditation Committee for Laboratories (CNAS) and accreditation number: L0310.
2.	The laboratory has obtained the accreditation of THE AMERICAN ASSOCIATION FOR LABORATORY ACCREDITATION (A2LA), and Accreditation Council Certificate Number: 2174.01.
3.	The laboratory has been listed on the US Federal Communications Commission list of test facilities recognized to perform electromagnetic emissions measurements. The site recognition number is 97456.
4.	The laboratory also has been listed by the VCCI to perform EMC measurements. The accreditation number is C1758, R1672, and T153.
5.	The test report is invalid if not marked with "exclusive stamp for the test report".
6.	Any copy of the test report is invalid if not re-marked with the "exclusive stamp for the test report".
7.	The test report is invalid if not marked with the stamps or the signatures of the persons responsible for performing, revising and approving the test report.
8.	The test report is invalid if there is any evidence of erasure and/or falsification.
9.	If there is any dissidence for the test report, please file objection to the test centre within 15 days from the date of receiving the test report.
10.	Normally, the test report is only responsible for the samples that have undergone the test.
11.	Context of the test report cannot be used partially or in full for publicity and/or promotional purposes without previous written approval of the laboratory.

REPORT ON FCC 47CFR part 15 subpart C Test of WCDMA/GPRS/GSM Mobile
Phone With Bluetooth

M/N: U1300/V725/Vodafone 725

Report No: SYBH(R) 028012008EB-3

REGULATION **FCC CFR47 Part 2: Subpart J;**
FCC CFR47 Part 15: Subpart C;

CONCLUSION **Pass**

General Manager

2008.02.23

Date

张兴海

Name

signature



**Technical Responsibility
For Area of Testing**

2008.02.23

Date

余 辉

Name

signature



Test Lab Engineer

2008.02.23

Date

胡 俊

Name

signature

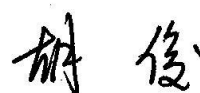

Contents

1	<u>Summary</u>	5
2	<u>Product Description</u>	6
2.1	PRODUCTION INFORMATION	6
2.2	MODIFICATION INFORMATION.....	6
3	<u>Test Site Description</u>	7
3.1	TESTING PERIOD	7
3.2	GENERAL SET UP DESCRIPTION	7
4	<u>Product Description</u>	8
4.1	TECHNICAL CHARACTERISTICS	8
4.2	EUT IDENTIFICATION LIST	10
5	<u>Main Test Instruments</u>	11
6	<u>Transmitter Measurements</u>	12
6.1	20dB BANDWIDTH MEASUREMENT	12
6.2	CARRIER FREQUENCY SEPARATION MEASUREMENT	14
6.3	NUMBER OF HOPPING CHANNEL.....	16
6.4	TIME OF OCCUPANCY	18
6.5	PEAK OUTPUT POWER.....	20
6.6	BAND EDGE SPURIOUS EMISSION	22
6.7	CONDUCTED RF SPURIOUS	24
6.8	RADIATED SPURIOUS EMISSION & SPURIOUS IN RESTRICTED BAND	26
6.9	CONDUCTED EMISSION AT POWER PORT	30
7	<u>System Measurement Uncertainty</u>	32
8	<u>Appendices</u>	33

1 Summary

The table below summarizes the measurements and results for the WCDMA/GPRS/GSM Mobile Phone With Bluetooth U1300/Vodafone 725/V725。 Detailed results and descriptions are shown in the following pages.

Table 1 Summary of results

FCC Measurement Specification	Description	Result
15.247 a (1)	20dB bandwidth measurement	PASS
15.247 a (1)	Carrier frequency separation measurement	PASS
15.247 a (1) iii	Number of hopping channel	PASS
15.247 a (1) iii	Time of occupancy	PASS
15.247 b (1)	Peak output power	PASS
15.247 d	Band edge compliance measurement	PASS
15.247 d	Conducted RF spurious	PASS
15.247 d / 15.205 & 15.209	Radiated spurious emission & Radiated restricted band measurement	PASS
15.207	Conducted emission test for power port	PASS

2 Product Description

2.1 Production Information

2.1.1 General Description

HUAWEI WCDMA/GPRS/GSM Mobile Phone With Bluetooth 1300/Vodafone 725/V725 is subscriber equipment in the WCDMA/GSM system. The WCDMA frequency band is Band I, can't be used in the USA. The GSM/GPRS frequency band includes E-GSM900 and DCS1800 and PCS1900. U1300/Vodafone 725/V725 implements such functions as RF signal receiving/sending, WCDMA and GSM/GPRS protocol processing, voice and data service etc. Externally it provides Micro SD card interface, earphone port (to provide voice service) and USIM card interface.

2.1.2 Support function and Service

The Mobile Phone U1300/Vodafone 725/V725 support the function and service as follows:

Table 2 Service and Test mode List

Service Name	Characteristic	Corresponding Test Mode	Note
Data and Voice	Modulation: GFSK	TM1	

2.2 Modification Information

For original equipment, following table is not application.

Table 3 Modification Information

Model Number	Board/Module	Original Version	New Version	Modify Information
Not applicable!				

3 Test Site Description

The test site of:

***Huawei Technologies Co. Ltd.
P.O. Box 518129
Huawei base, bantian,
Longgang District, Shenzhen, China***

The test site description has been submitted to  and registration granted under the registration number **97456** on March 11, 2003. The test site has been accredited by



and the accredited number is **2174.01** in Jan of 2004.

3.1 Testing Period

The test have been performed during the period of

Feb.21, 2008 to Feb.23, 2008

3.2 General Set up Description

The Bluetooth hopping frequency system of Mobile Phone U1300 can Support 2.4GHz Band. For compliance with FCC regulation 47CFR part15 subpart C, we set the mobile phone as following test mode to do all compliance tests.

Bluetooth MODE:

TM1: GFSK Modulation

4 Product Description

4.1 Technical Characteristics

4.1.1 Frequency Range

Table 4 Frequency Range

Uplink band:	2400 to 2483.5 MHz	
Downlink band:	2400 to 2483.5 MHz	
Hop frequency support:	<input checked="" type="checkbox"/> YES	<input type="checkbox"/> NO

4.1.2 Channel Spacing / Separation

Table 5 Channel Spacing / Separation

Channel spacing:	1 MHz
Channel separation:	1 MHz

4.1.3 Type of Emission

Table 6 Type of Emission

Emission Designation:	-
-----------------------	---

According to CFR 47 (FCC) part 2, subpart C, section 2.201 and 2.202

4.1.4 Antenna Information

Table 7 Antenna Information

Type:	Integrated / Internal
Maximum Gain(dBi):	0.09 (from 2400MHz to 2500MHz)

4.1.5 Environmental Requirements

Table 8 Environmental Requirements

Minimum temperature:	- 10 °C
Maximum temperature:	+ 55 °C
Relative Humidity:	5%-95%

4.1.6 Power Source

Table 9 Power Source

AC voltage nominal:	~120V
AC voltage range	~100V-240V
AC current maximal:	650mA

4.1.7 Tune-up Procedure

According to CFR (FCC) part 2, subpart 2, section 2.1033(c) (9).

Please reference the document Tune-up Procedure in TCF.

4.1.8 Applied DC Voltages and Currents

According to CFR (FCC) part 2, subpart 2, section 2.1033(c) (8).

The voltage and current in the final RF stage is:

Table 10 Applied RF module DC Voltages and Currents

Voltage:	 +2.8V
Current:	100mA According to CFR (FCC) part 2, subpart 2, section 2.1033(c) (8)

4.2 EUT Identification List

4.2.1 Board Information

Table 11 Board Information

WCDMA/GPRS/GSM Mobile Phone with Bluetooth		
U1300/Vodafone 725/V725		
Board and Module		
Equipment Designation / Description	Model	Remarks
-Main board	HD1U130M	VER.B
-Battery	HBU570	900mAh

4.2.2 Adapter Technical Data

AC/DCAdapter Model	CHG5365-3C / TPCA053065UY
Manufacturer	Shenzhen Chi Yuan Industrial Co., Ltd / TECH-POWER INTERNATIONAL CO.,LTD
Input Voltage	~ 100V-240V/50-60Hz
Output Voltage	--- +5.3V, 0.65A
Rated Power	4W
S/N	HKY7C1100099/ TPI6B2500389

4.2.3 Battery Technical Data

Type:	Rechargeable Li-ion
Manufacturer:	FMT Electronics Co.,Ltd.
Battery Model:	HBU570
Rated capacity:	900mAh
Nominal Voltage:	--- +3.7V
Charging Voltage:	--- +4.2V

4.2.4 FCC Identification

Grantee Code: QIS
Product Code: U1300
FCC Identification: QISU1300

5 Main Test Instruments

Table 12 Main Test Equipments

Equipment Description	Manufacturer	Model	Serial Number	Calibrated until (MM.DD.YYYY)
Signal Analyzer	R&S	FSQ 40	100025	09.05.2008
Test Receiver Display Unit	R&S	ESMI 804.8932.52	829214/011	04.22.2008
Test Receiver RF Unit	R&S	ESMI 1032.5640.53	829550/008	04.22.2008
Receiver	R&S	ESIB 26	100318	05.29.2008
Receiver	R&S	ESCS30	830245/018	05.29.2008
Pre-Amplifier	Agilent	8447D	2944A10146	05.20.2008
Pre-Amplifier	Agilent	83017A	3950M00246	02.04.2008
Loop Antenna	Schwarzbeck	FMZB1516	115	01.06.2008
BiLog Antenna	Schaffner	CBL 6112B	2536	06.07.2008
Horn Antenna	R&S	HF906 4044.4507.02	359287/005	02.15.2008
Horn Antenna	ETS-Lindgren	3117	00062549	09.14.2007
Horn Antenna	ETS-Lindgren	3116	00031541	07.15.2008
Signal Generator	R&S	SMR 40	100325	07.03.2008
Artificial Mains Network	R&S	ENV4200	100001	05.20.2008
Universal Radio Communication Tester	R&S	CMU200	108035	07.03.2008

6 Transmitter Measurements

6.1 20dB bandwidth measurement

6.1.1 Test Conditions

Table 13 Test Conditions

Preconditioning:	0.5 hour
Measured at:	Antenna connector
Ambient temperature:	23.5°C
Relative humidity:	55%
Test Configurations:	TM1 at channel No.0、40、78

6.1.2 Test Specifications and Limits

6.1.2.1 Specification

CFR 47 (FCC) part 15.247 a (1) and DA 00-705

6.1.2.2 Supporting Standards

Table 14 Supporting Standards:

ANSI/TIA-603-C:2004	Land Mobile FM or PM Communications Equipment Measurement and Performance Standards
---------------------	---

6.1.2.3 Limits

Not Applicable.

6.1.3 Test Method and Setup

- (a) Connect test port of mobile phone to spectrum analyzer and universal communication tester.
- (b) Set the mobile phone to transmit maximum output power at 2.4GHz and switch off frequency hopping function, then set the measured frequency number and test the 20dB bandwidth with spectrum analyzer.

Test setup

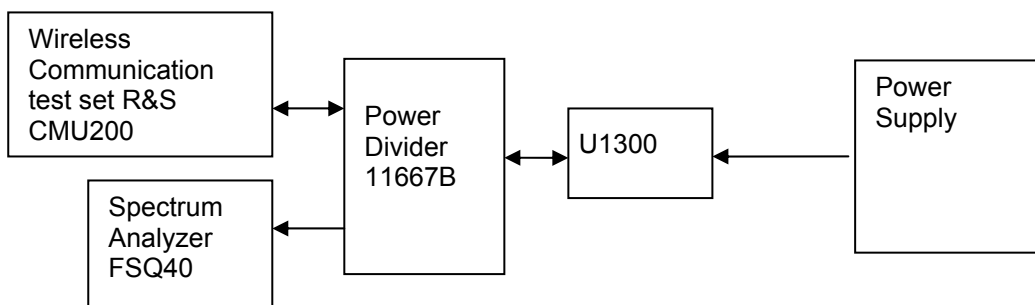

Figure 1. Test Set-up

6.1.4 Measurement Results

Table 15 Measurement Results

Bandwidth Type	Channel Position	Channel Number	Frequency [GHz]	Measured Bandwidth [MHz]	Result
20dB	B	0	2.402	0.996	Pass
20dB	M	40	2.442	0.996	Pass
20dB	T	78	2.480	1.000	Pass

6.1.5 Conclusion

The equipment **PASSED** the requirement of this clause.
 For the measurement results refer to appendix A.

6.2 Carrier frequency separation measurement

6.2.1 Test Conditions

Table 16 Test Conditions

Preconditioning:	0.5 hour
Measured at:	Antenna connector
Ambient temperature:	23.5°C
Relative humidity:	55%
Test Configurations:	TM1 at channel No.37, 38, 39

6.2.2 Test Specifications and Limits

6.2.2.1 Specification

CFR 47 (FCC) part 15.247 a (1) and DA 00-705

6.2.2.2 Supporting Standards

Table 17 Supporting Standards:

ANSI/TIA-603-C:2004	Land Mobile FM or PM Communications Equipment Measurement and Performance Standards
---------------------	---

6.2.2.3 Limits

Frequency hopping systems shall have hopping channel carrier frequencies separated by a minimum of 25 kHz or the 20 dB bandwidth of the hopping channel, whichever is greater. Alternatively, frequency hopping systems operating in the 2400-2483.5 MHz band may have hopping channel carrier frequencies that are separated by 25 kHz or two-thirds of the 20 dB bandwidth of the hopping channel, whichever is greater.

Table 18 Limits

Regulation:	≥ 0.025 or $2/3$ of the 20 dB bandwidth
Limit:	$\geq 2/3 \times 1.000 = 0.667\text{MHz}$

6.2.3 Test Method and Setup

- (a) Connect test port of mobile phone to spectrum analyzer and universal communication tester.
- (b) Set the mobile phone to transmit maximum output power at 2.4GHz and switch off frequency hopping function, then set the measured frequency number to two adjacent channels separately and test the carrier frequency separation with spectrum analyzer.

Test setup

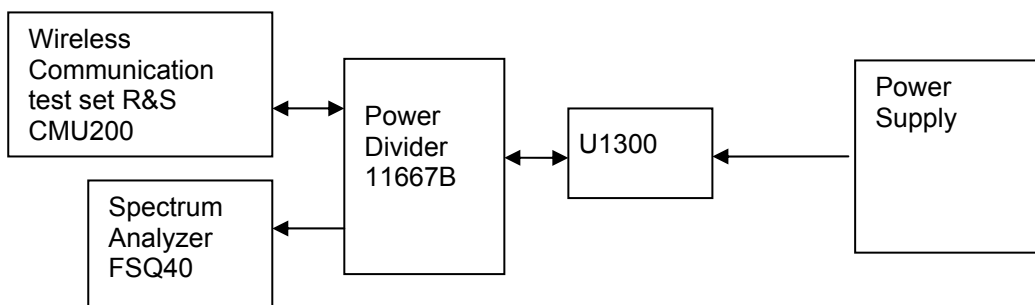

Figure 2. Test Set-up

6.2.4 Measurement Results

Table 19 Measurement Results

Channel No.	Frequency [GHz]	Channel No.	Frequency [GHz]	Measured frequency separation [MHz]	Limit [MHz]	Result
38	2.440	37	2.439	1.0016	≥0.662	Pass
38	2.440	39	2.441	1.0096	≥0.662	Pass

6.2.5 Conclusion

For the measurement results refer to appendix B.

6.3 Number of hopping channel

6.3.1 Test Conditions

Table 20 Test Conditions

Preconditioning:	0.5 hour
Measured at:	Antenna connector
Ambient temperature:	22 °C
Relative humidity:	52 %
Test Configurations:	TM1 at hopping frequency state

6.3.2 Test Specifications and Limits

6.3.2.1 Specification

CFR 47 (FCC) part 15.247 a (1)iii and DA 00-705

6.3.2.2 Supporting Standards

Table 21 Supporting Standards:

ANSI/TIA-603-C: 2004	Land Mobile FM or PM Communications Equipment Measurement and Performance Standards
----------------------	---

6.3.2.3 Limits

Number of hopping channel should be compliance with the requirements in part15.247 a (1) iii.

Table 22 Limits

Limits	≥ 15 hopping frequency channel
--------	-------------------------------------

6.3.3 Test Method and Setup

- Connect test port of mobile phone to spectrum analyzer and universal communication tester.
- Set the mobile phone to transmit maximum output power at 2.4GHz and switch on frequency hopping function, then set enough count time (larger than 5000 times) to get all the hopping frequency channel displayed on the screen of spectrum analyzer.
- Count the quantity of peaks to get the number of hopping channels.

Test setup

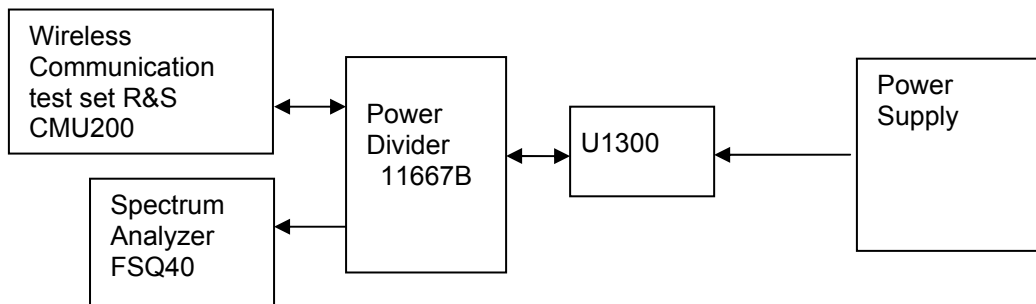

Figure 3. Test Set-up

6.3.4 Measurement Results

Table 23 Measurement Results

Measured frequency range [MHz]	Channel No. range	Measured Channel No.	Limit	Result
2400 to 2483.5	0-78	79	>15	Pass

6.3.5 Conclusion

The equipment **PASSED** the requirement of this clause.
 For the measurement results refer to appendix C.

6.4 Time of occupancy

6.4.1 Test Conditions

Table 24 Test Conditions

Preconditioning:	0.5 hour
Measured at:	Antenna connector
Ambient temperature:	25 °C
Relative humidity:	55 %
Test Configurations:	TM1 at hopping frequency state

6.4.2 Test Specifications and Limits

6.4.2.1 Specification

CFR 47 (FCC) part 15.247 a (1)iii and DA 00-705

6.4.2.2 Supporting Standards

Table 25 Supporting Standards:

ANSI/TIA-603-C: 2004	Land Mobile FM or PM Communications Equipment Measurement and Performance Standards
----------------------	---

6.4.2.3 Limits

The average time of occupancy on any channel shall not be greater than 0.4 seconds within a period of 0.4 seconds multiplied by the number of hopping channels employed. Frequency hopping systems may avoid or suppress transmissions on a particular hopping frequency provided that a minimum of 15 channels are used.

Table 26 Limits

Limits for time of occupancy	$\leq 0.4s$
------------------------------	-------------

6.4.3 Test Method and Setup

- (a) Connect test port of mobile phone to spectrum analyzer and universal communication tester.
- (b) Set the mobile phone to transmit maximum output power at 2.4GHz and switch on frequency hopping function.
- (c) Set the span of spectrum analyzer to 0 Hz, and set the resolution bandwidth to 1 MHz and the video bandwidth to 1 MHz, then get the time domain measured diagram. and set sweep time to 2 times of one burst occupancy time, and measure the time of occupancy of one burst.
- (d) Set the resolution bandwidth to 1 MHz and the video bandwidth to 3 MHz, and set the sweep time to a period (0.4 seconds multiplied by the number of hopping channels employed), and count the number of the bursts.
- (e) Calculate the time of occupancy in a period with time occupancy of a burst and quantity of bursts.

Test setup

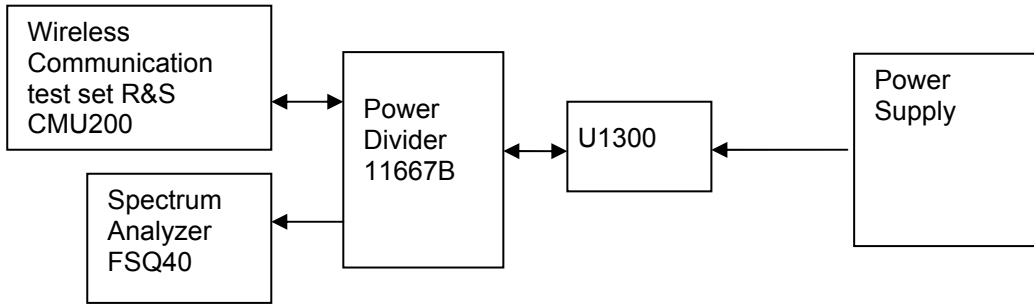

Figure 4. Test Set-up

6.4.4 Measurement Results

Table 27 Measurement Results

Time of Single Slot [ms]	Numbers of slots in a period	Time of occupied in a period [s]	Limit [s]	Result
2.937409	106.7	0.3134215403	≤ 0.4	Pass

Note: The result is measured at DH5 mode in GFSK modulation, which has longest time in one transmission burst.

6.4.5 Conclusion

The equipment **PASSED** the requirement of this clause.
For the measurement results refer to appendix D.

6.5 Peak output power

6.5.1 Test Conditions

Table 28 Test Conditions

Preconditioning:	0.5 hour
Measured at:	Antenna connector
Ambient temperature:	23.5°C
Relative humidity:	55 %
Test Configurations:	TM1 at channel No.0、40、78

6.5.2 Test Specifications and Limits

6.5.2.1 Specification

CFR 47 (FCC) part 15.247 b (1) and DA 00-705

6.5.2.2 Supporting Standards

Table 29 Supporting Standards:

ANSI/TIA-603-C: 2004	Land Mobile FM or PM Communications Equipment Measurement and Performance Standards
----------------------	---

6.5.2.3 Limits

Compliance with part 15.247 b (1), for frequency hopping systems operating in the 2400-2483.5 MHz band employing at least 75 non-overlapping hopping channels, and all frequency hopping systems in the 5725-5850 MHz band: 1 watt. For all other frequency hopping systems in the 2400-2483.5 MHz band: 0.125 watt.

Table 30 Limits

2.4GHz and 5.8GHz hopping frequency system	1 Watt / 30 dBm
Other frequency hopping systems	0.125 Watts / 21 dBm

6.5.3 Test Method and Setup

- (a) Connect test port of mobile phone to spectrum analyzer and universal communication tester.
- (b) Set the mobile phone to transmit maximum output power at 2.4GHz and switch off frequency hopping function.
- (c) Then set the mobile phone to transmit at high, middle and low frequency and measure the conducted output power separately.

Test setup

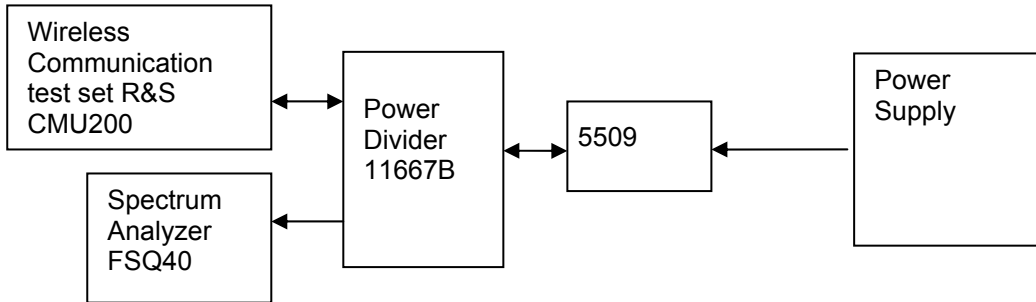

Figure 5. Test Set-up

6.5.4 Measurement Results

Table 31 Measurement Results

Channel	Channel No.	Center Freq.[MHz]	Meas. Level (Cond.) [dBm]	Limit [dBm]	Result
Bottom	0	2402	-0.82	< 30	Pass
Middle	40	2442	-1.09	< 30	Pass
Top	78	2480	-2.41	< 30	Pass

6.5.5 Conclusion

The equipment **PASSED** the requirement of this clause.
 For the measurement results refer to appendix E.

6.6 Band edge spurious emission

6.6.1 Test Conditions

Table 32 Test Conditions

Preconditioning:	0.5 hour
Measured at:	Antenna connector
Ambient temperature:	20°C
Relative humidity:	50 %
Test Configurations:	TM1 at channel No. 0, 78 and frequency hopping state

6.6.2 Test Specifications and Limits

6.6.2.1 Specification

CFR 47 (FCC) part 15.247 d and DA 00-705

6.6.2.2 Supporting Standards

Table 33 Supporting Standards:

ANSI/TIA-603-C: 2004	Land Mobile FM or PM Communications Equipment Measurement and Performance Standards
----------------------	---

6.6.2.3 Limits

Compliance with part 15.247 (d), in any 100 kHz bandwidth outside the frequency band in which the spread spectrum or digitally modulated intentional radiator is operating, the radio frequency power that is produced by the intentional radiator shall be at least 20 dB below that in the 100 kHz bandwidth within the band that contains the highest level of the desired power, based on either an RF conducted or a radiated measurement, provided the transmitter demonstrates compliance with the peak conducted power limits. If the transmitter complies with the conducted power limits based on the use of RMS averaging over a time interval, as permitted under paragraph (b)(3) of this section, the attenuation required under this paragraph shall be 30 dB instead of 20 dB. Attenuation below the general limits specified in Section 15.209(a) is not required.

Table 34 Limits

Band edge spurious:	20 dBc/100kHz
---------------------	---------------

6.6.3 Test Method and Setup

- (a) Connect test port of mobile phone to spectrum analyzer and universal communication tester
- (b) Set the mobile phone to transmit maximum output power at 2.4GHz and switch off frequency hopping function.
- (c) Then set the mobile phone to transmit at high, low frequency and measure the conducted band edge spurious separately.
- (d) Switch on the frequency hopping function, and repeat above measurement.

Test setup

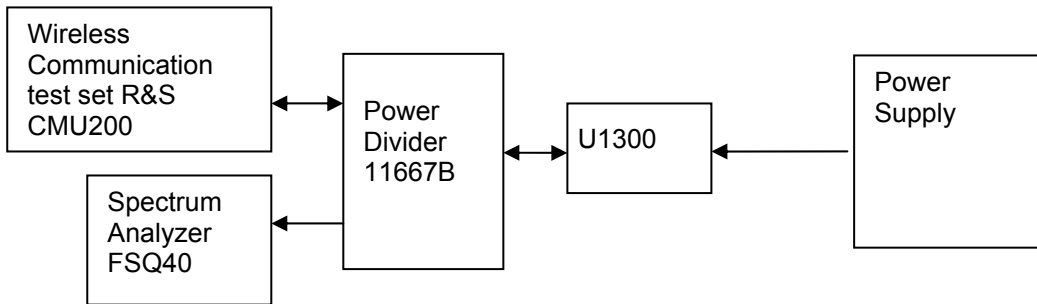

Figure 6. Test Set-up

6.6.4 Measurement Results

Table 35 Measurement Results

	Channel No.	Carrier Frequency [MHz]	Carrier Power [dBm]	Frequency Hopping	Max. Spurious Level [dBm]	Limit [dBm]	Result
Low Edge	0	2402	-1.19	Off	-43.50	<-21.19	Pass
	-	-	-1.37	On	-42.13	<-21.37	Pass
High Edge	78	2480	-2.76	Off	-41.95	<-22.76	Pass
	-	-	-1.77	On	-43.69	<-21.77	Pass

6.6.5 Conclusion

The equipment **PASSED** the requirement of this clause.
 For the measurement results refer to appendix F.

6.7 Conducted RF spurious

6.7.1 Test Conditions

Table 36 Test Conditions

Preconditioning:	0.5 hour
Measured at:	Antenna connector
Ambient temperature:	22 °C
Relative humidity:	53 %
Test Configurations:	TM1 at channel No.0、40、78

6.7.2 Test Specifications and Limits

6.7.2.1 Specification

CFR 47 (FCC) part 15.247 d and DA 00-705

6.7.2.2 Supporting Standards

Table 37 Supporting Standards:

ANSI/TIA-603-C: 2004	Land Mobile FM or PM Communications Equipment Measurement and Performance Standards
----------------------	---

6.7.2.3 Limits

Compliance with part 15.247 (d), in any 100 kHz bandwidth outside the frequency band in which the spread spectrum or digitally modulated intentional radiator is operating, the radio frequency power that is produced by the intentional radiator shall be at least 20 dB below that in the 100 kHz bandwidth within the band that contains the highest level of the desired power, based on either an RF conducted or a radiated measurement, provided the transmitter demonstrates compliance with the peak conducted power limits. If the transmitter complies with the conducted power limits based on the use of RMS averaging over a time interval, as permitted under paragraph (b)(3) of this section, the attenuation required under this paragraph shall be 30 dB instead of 20 dB. Attenuation below the general limits specified in Section 15.209(a) is not required.

Table 38 Limits

Band edge spurious:	20 dBc/100kHz
---------------------	---------------

6.7.3 Test Method and Setup

- (a) Connect test port of mobile phone to spectrum analyzer and universal communication tester
- (b) Set the mobile phone to transmit maximum output power at 2.4GHz and switch off frequency hopping function.
- (c) Then set the mobile phone to transmit at high, middle and low frequency and measure the conducted band edge spurious separately.
- (d) Switch on the frequency hopping function, and repeat above measurement.

Test setup

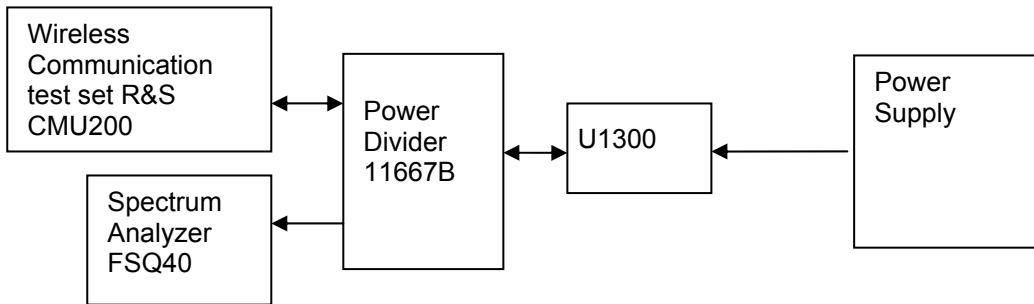

Figure 7. Test Set-up

6.7.4 Measurement Results

6.7.4.1 Measurement Results

Table 39 Measurement Results

Test Frequency Range	Channel No.	Carrier Frequency [MHz]	Carrier Power [dBm]	Frequency Hopping	Max. Spurious Level [dBm]	Limit [dBm]	Result
9kHz-26GHz	0	2402	-1.71	Off	<-25	<-21.71	Pass
9kHz-26GHz	40	2442	-1.82	Off	<-25	<-21.82	Pass
9kHz-26GHz	78	2480	-3.07	Off	<-25	<-23.07	Pass

6.7.5 Conclusion

The equipment **PASSED** the requirement of this clause.
 For the measurement results refer to appendix G.

6.8 Radiated spurious emission & spurious in restricted band

6.8.1 Test Conditions

Table 40 Test Conditions

Preconditioning:	0.5 hour
Measured at:	Enclosure
Ambient temperature:	25 °C
Relative humidity:	55 %
Test Configurations:	TM1 at channel No.0、 40、 78

6.8.2 Test Specifications and Limits

6.8.2.1 Specification

CFR 47 (FCC) part 15.247 d, 15.205 & 15.209 and DA 00-705

6.8.2.2 Supporting Standards

Table 41 Supporting Standards:

ANSI/TIA-603-C: 2004	Land Mobile FM or PM Communications Equipment Measurement and Performance Standards
ANSI C63.4: 2003	Methods of Measurement of Radio-Noise Emissions from Low Voltage Electrical and Electronic Equipment in the Range of 9 kHz to 40 GHz

6.8.2.3 Limits

According to part 15.247 d / 15.205 & 15.209, all spurious emission in the frequency range from 30MHz to 10th harmonics of carrier frequency should be meet the requirement of following table.

Table 42 Limits

Frequency (MHz)	Field Strength (μV/m)	Field Strength (dBμV/m)	Measurement Distance (meters)	Detector
30 – 88	100	40	3	QP
88 – 216	150	43.5	3	QP
216 – 960	200	46	3	QP
960 -1000	500	54	3	QP
Above 1000	500	54	3	PK

In addition, radiated emissions which fall in the restricted bands, as defined in Section 15.205(a), also should comply with the radiated emission limits specified in Section 15.209(a)(above table 42).

6.8.3 Test Method and Setup

The test site semi-anechoic chamber has met the requirement of NSA tolerance 4dB according to the standards: ANSI C63.4 (2003). The EUT was set-up on insulator 80cm above the Ground Plane. The set-up and test methods were according to ANSI C63.4.The Radiated Disturbance measurements were made using a Rohde and Schwarz Test Receiver and control software.

A preliminary scan and a final scan of the emissions were made by using test script of software; the emissions were measured using a Quasi-Peak Detector below 1GHz, and AV detector above 1GHz.

The maximal emission value was acquired by adjusting the antenna height, polarisation and turntable azimuth in accordance with the software setup. Normally, the height range of antenna was 1m to 4m, the azimuth range of turntable was 0° to 360°, The receive antenna has two polarizations V and H.

Huawei Mobile Phone was communicated with the BTS simulator through Air interface. The Mobile Phone operated on the typical channel and the Mobile Phone worked in idle mode, transmitter was not work in this test.

Measurement bandwidth: 30 MHz – 1000 MHz: 120 k Hz
 Measurement bandwidth: 1000 MHz – 10th Carrier Frequency: 1 MHz

Test set up

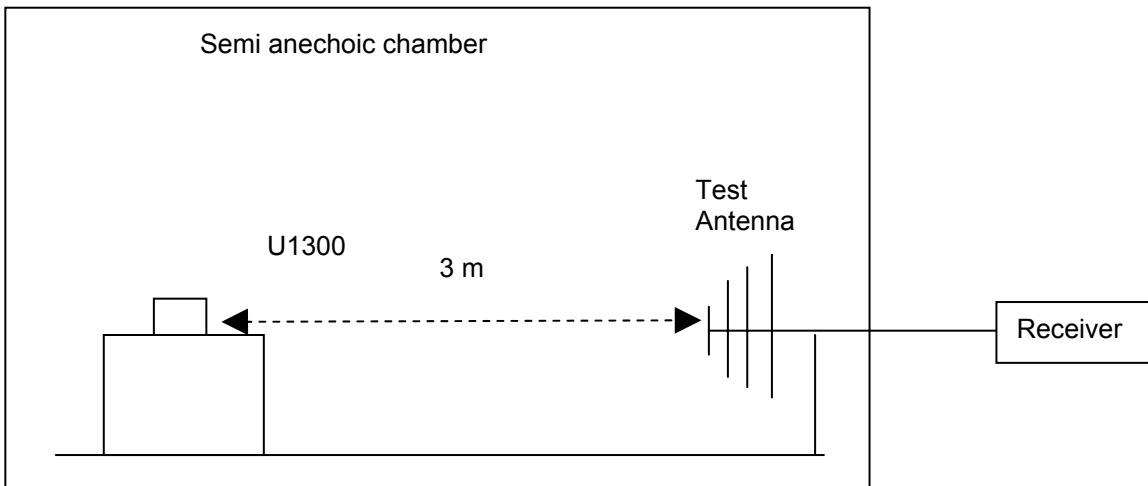

Figure 8. Test Set up

6.8.4 Measurement Results

6.8.4.1 Measurement Result

Note: The following measurement results exceed the limit line is the carrier frequency.

Measured Result of channel: 0 (2402MHz)

Table 43 MEASUREMENT RESULT

Frequency (MHz)	Level (dBμV/m)	Transd (dB)	Limit (dBμV/m)	Margin (dB)	Height (cm)	Azimuth (deg)	Polarisation
40.680000	33.50	-10.0	40.0	6.5	100.0	75.00	VERTICAL
53.880000	28.20	-15.2	40.0	11.8	100.0	170.00	VERTICAL
148.320000	16.70	-11.1	43.5	26.8	193.0	38.00	VERTICAL
229.200000	19.00	-10.3	46.0	27.0	150.0	356.0	VERTICAL
542.340000	24.10	-1.9	46.0	21.9	100.0	156.00	HORIZONTAL
984.060000	30.60	2.4	54.0	23.4	133.0	14.00	VERTICAL
1100.000000	40.10	-6.5	54.0	13.9	100.0	300.00	HORIZONTAL
2402.000000	74.80	2.0	54.0	-20.8	100.0	12.00	VERTICAL
3750.000000	45.50	7.0	54.0	8.5	100.0	0.00	VERTICAL
5925.500000	49.10	12.7	54.0	4.9	200.0	0.00	HORIZONTAL
12921.000000	47.20	31.6	54.0	6.8	100.0	150.00	HORIZONTAL
19530.000000	50.10	38.0	54.0	3.9	300.0	270.00	VERTICAL

Measured Result of channel: 40 (2442MHz)

Table 44 MEASUREMENT RESULT

Frequency (MHz)	Level (dBμV/m)	Transd (dB)	Limit (dBμV/m)	Margin (dB)	Height (cm)	Azimuth (deg)	Polarisation
40.680000	33.50	-10.0	40.0	6.5	100.0	75.00	VERTICAL
53.880000	28.20	-15.2	40.0	11.8	100.0	170.00	VERTICAL
148.320000	16.70	-11.1	43.5	26.8	193.0	38.00	VERTICAL
229.200000	19.00	-10.3	46.0	27.0	150.0	356.0	VERTICAL
542.340000	24.10	-1.9	46.0	21.9	100.0	156.00	HORIZONTAL
984.060000	30.60	2.4	54.0	23.4	133.0	14.00	VERTICAL
1380.000000	41.10	-5.0	54.0	12.9	200.0	300.00	HORIZONTAL
2442.000000	71.90	2.1	54.0	-17.9	100.0	276.00	VERTICAL
3750.000000	43.90	7.0	54.0	10.1	100.0	4.00	VERTICAL
6990.500000	48.10	18.6	54.0	5.9	110.0	26.00	VERTICAL
9980.000000	49.10	25.1	54.0	4.9	300.0	286.00	HORIZONTAL
24998.000000	52.50	52.1	54.0	1.5	300.0	115.00	VERTICAL

Measured Result of channel: 78 (2480MHz)

Table 45 MEASUREMENT RESULT

Frequency (MHz)	Level (dBμV/m)	Transd (dB)	Limit (dBμV/m)	Margin (dB)	Height (cm)	Azimuth (deg)	Polarisation
40.680000	33.50	-10.0	40.0	6.5	100.0	75.00	VERTICAL
53.880000	28.20	-15.2	40.0	11.8	100.0	170.00	VERTICAL
148.320000	16.70	-11.1	43.5	26.8	193.0	38.00	VERTICAL
229.200000	19.00	-10.3	46.0	27.0	150.0	356.0	VERTICAL
542.340000	24.10	-1.9	46.0	21.9	100.0	156.00	HORIZONTAL
984.060000	30.60	2.4	54.0	23.4	133.0	14.00	VERTICAL
1100.000000	40.50	-6.5	54.0	13.5	180.0	260.00	VERTICAL
2480.000000	69.70	2.3	54.0	-25.7	100.0	200.00	VERTICAL
5087.500000	47.00	12.1	54.0	7.0	179.0	270.00	VERTICAL
19530.000000	50.10	38.0	54.0	3.9	100.0	200.00	VERTICAL

Table 46 Measurement Results for Band Edge(2310 MHz -2390MHz, 2483.5 MHz -2500MHz)

Channel No	Channel No	Carrier Frequency [MHz]	Max. Delta Spurious Level [dB]	Carrier Frequency Level test in 3 meters [dBμV/m]	Band Edge Max. Spurious Level [dBμV/m]	Limit (AV) [dBμV/m]	Result
Low Edge	0	2310-2390	42.53	74.80	32.27	54	Pass
High Edge	78	2483.5-2500	40.96	69.70	28.74	54	Pass

Notes:

1. Band Edge Max. Spurious Level= Carrier Frequency Level test in 3 meters- Max. Delta Spurious Level;
2. Max. Delta Spurious Level is got from the Band Edge test result appendix F;
3. The Carrier Frequency Levels test in 3 meters are got from the radiated spurious emission which is appendix H;
4. Because the PK detector value is smaller than AV Limit line, so the AV detector value is certainly smaller than AV limit line.

6.8.5 Conclusion

The equipment **PASSED** the requirement of this clause.

For the measurement results refer to appendix H.

6.9 Conducted Emission at Power Port

6.9.1 Test Conditions

Table 47 Test Conditions

Preconditioning:	0.5 hour
Measured at:	Power port
Ambient temperature:	23.5°C
Relative humidity:	55 %
Test Configurations:	TM1 at channel No. 40

6.9.2 Test Specifications and Limits

6.9.2.1 Specification

CFR 47 (FCC) part 15.207 and DA 00-705

6.9.2.2 Supporting Standards

Table 48 Supporting Standards:

ANSI C63.4: 2003	Methods of Measurement of Radio-Noise Emissions from Low Voltage Electrical and Electronic Equipment in the Range of 9 kHz to 40 GHz
------------------	--

6.9.2.3 Limits

Compliance with part15.207, conducted emission must meet the requirement of following table.

Table 49 Limits

Frequency of Emission (MHz)	Conducted Limit (dB μ V)	
	Quasi-peak	Average
0.15-0.5	66 to 56 *	56 to 46 *
0.5-5	56	46
5-30	60	50

Note: * Decreases with the logarithm of the frequency.

6.9.3 Test Method and Setup

The Table-top EUT was placed upon a non-metallic table 0.8 m above the horizontal metal reference ground plane. EUT was connected to LISN and LISN was connected to reference Ground Plane. EUT was 80cm from LISN. The set-up and test methods were according to ANSI C63.4: 2003.

Conducted Disturbance at AC Port measurements were undertaken on the L and N Lines. The emissions were measured using a Quasi-Peak Detector and Average Detector.

Huawei Mobile phone was communicated with the BTS simulator through Air interface, the BTS simulator controls the Mobile Phone to transmitter the maximum power which defined in specification of product. The Mobile Phone operated on the typical channel.

Measurement bandwidth (RBW) for 150kHz to 30 MHz: 9 kHz;

Test Set-up

The Mobile Phone was setup in the screened chamber and operated under nominal conditions.

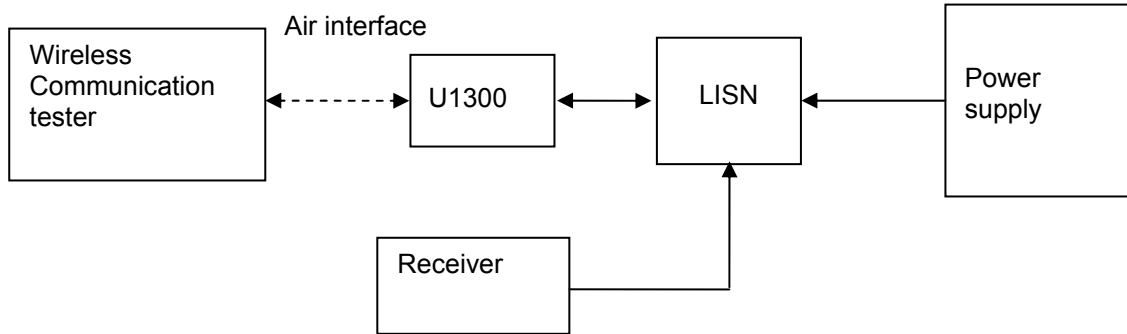

Figure 9. Test Set-up

6.9.4 Measurement Results

Table 50 MEASUREMENT RESULT:QP DECTER

Frequency MHz	Level dBµV	Transd dB	Limit dBµV	Margin dB	Detector	Line	PE
0.195000	41.90	10.1	64	22.1	QP	N	GND
0.843000	39.90	10.0	56	16.1	QP	L3	GND
1.824000	45.70	10.1	56	10.3	QP	L3	GND
3.408000	41.80	10.1	56	14.2	QP	L3	GND
5.613000	41.10	10.1	60	18.9	QP	L3	GND
29.607000	35.40	10.5	60	24.6	QP	L3	GND

Table 51 MEASUREMENT RESULT:AV DECTER

Frequency MHz	Level dBµV	Transd dB	Limit dBµV	Margin dB	Detector	Line	PE
0.199500	28.90	10.1	54	25.1	AV	N	GND
0.843000	25.30	10.0	46	20.7	AV	L3	GND
1.797000	29.40	10.0	46	16.6	AV	L3	GND
2.697000	31.00	10.1	46	15.0	AV	L3	GND
5.392500	28.00	10.1	50	22.0	AV	L3	GND
29.665500	21.80	10.5	50	28.2	AV	L3	GND

6.9.5 Conclusion

The equipment **PASSED** the requirement of this clause.
 For the measurement results refer to appendix I.

7 System Measurement Uncertainty

For a 95% confidence level, the measurement expanded uncertainties for defined systems, in accordance with the recommendations of ISO 17025 as following:

Table 52 System Measurement Uncertainty

Items		Extended Uncertainty
20dB bandwidth measurement	Magnitude (%)	U=0.2%; k=2
Carrier frequency separation measurement	Magnitude (%)	U=0.2%; k=2
Time of occupancy	Magnitude (%)	U=0.2%; k=2
Peak output power	Power(dBm)	U=0.39dB; k=2
Band edge compliance measurement	Disturbance Power(dBm)	U=2.0dB; k=2
Conducted RF spurious	Disturbance Power(dBm)	U=2.0dB; k=2
Radiated spurious emission & Radiated restricted band measurement	Field strength (dB μ V/m)	U=2.2dB; k=2 U=5dB; k=2
Conducted emission test for power port	Disturbance Voltage(dB μ V)	U=4dB; k=2

8 Appendices

Appendix A	Measurement Results 20dB bandwidth measurement	4 pages
Appendix B	Measurement Results Carrier frequency separation measurement	2 pages
Appendix C	Measurement Results Number of hopping channel	2 pages
Appendix D	Measurement Results Time of occupancy	3 pages
Appendix E	Measurement Results Peak output power	4 pages
Appendix F	Measurement Results Band edge compliance measurement	9 pages
Appendix G	Measurement Results Conducted RF spurious	10 pages
Appendix H	Measurement Results Radiated spurious emission	7 pages
Appendix I	Measurement Results Conducted emission test for power port	2 pages
Appendix J	Photos of Test Setup	4 pages