

CHAPTER 10

FORKLIFT TRUCKS

This chapter specifies operation, inspection, testing, and maintenance requirements for forklift trucks powered by internal-combustion engines or electric motors and implements the requirements of ANSI/ITSDF B56.1 (“Safety Standard for powered Industrial Trucks – Low Lift and High lift Trucks”) and ANSI/ITSDF B56.6 (“Rough Terrain Fork Lift Trucks”), and ANSI/UL 558 (“Internal-Combustion-Engine-Powered Industrial Trucks”) and ANSI/UL 583 (“Electric-Battery-Powered Industrial Trucks”).

10.1	GENERAL	10-1
10.1.1	Operator Training/Qualification	10-1
10.1.2	Rated Capacity	10-1
10.1.3	Nameplates and Markings.....	10-1
10.1.3.1	Fork Arm Data.....	10-1
10.1.4	Attachments	10-1
10.1.5	Modification	10-2
10.1.6	Warning Devices.....	10-2
10.1.7	Overhead Guards	10-2
10.1.8	Fire Hazards	10-2
10.1.9	Work Atmosphere.....	10-2
10.2	TYPE DESIGNATION AND AREAS OF USE.....	10-11
10.2.1	Type Designation.....	10-11
10.2.1.1	Non-Hazardous Areas	10-11
10.2.1.2	Hazardous Areas.....	10-11
10.2.2	Specific Areas of Use.....	10-12
10.3	INSPECTIONS	10-15
10.3.1	Daily Pre-Operational Check	10-15
10.3.2	Initial Inspection of New and Rented Equipment	10-15
10.3.3	Inspection and Maintenance	10-15
10.3.4	Forks	10-16
10.3.4.1	Fork Load Ratings	10-16
10.3.4.2	Fork Inspections	10-16
10.3.4.3	Fork Repair.....	10-17
10.3.5	Battery Maintenance	10-17
10.3.6	History File	10-18
10.4	TESTING.....	10-19
10.4.1	Forklift Truck Load Test.....	10-19
10.4.2	Fork Load Test.....	10-19
10.4.3	Attachment Load Test.....	10-19
10.5	OPERATIONS.....	10-20
10.5.1	Conduct of Operator	10-20
10.5.1.1	General	10-20
10.5.1.2	Traveling	10-21
10.5.1.3	Loading.....	10-22
10.5.2	Lifting of Personnel	10-23
10.5.3	Standard Hand Signals	10-25
10.5.4	Ordinary Lifts	10-25
10.5.5	Critical Lifts	10-25
10.5.6	Equipment Qualifications	10-25

DOE-STD-1090-2007

Exhibit I Operators Pre-Shift Inspection Form 10-30
Exhibit II Forklift Load Test and Inspection Form 10-32

10.1 GENERAL

This chapter specifies operation, inspection, testing, and maintenance requirements for industrial trucks powered by electric motors or internal-combustion engines. See Figures 10-3 for examples of powered industrial trucks.

Guidelines may also be taken from this chapter regarding pallet trucks and other small miscellaneous non-powered lift trucks (see Figure 10-4), but training, operating, maintenance, inspection, and testing requirements for non-powered equipment shall be based on the manufacturer's instructions and recommendations.

10.1.1 OPERATOR TRAINING/ QUALIFICATION

Operators of forklift trucks shall be trained and qualified as described in Chapter 6, "Personnel Qualification and Training."

10.1.2 RATED CAPACITY

Rated capacity is the maximum weight the truck can transport and stack at a specified load center and for a specified load elevation. Trucks shall not be used or tested above their rated capacities.

10.1.3 NAMEPLATE(S) AND MARKINGS

Every truck shall have appended to it a durable, corrosion-resistant nameplate(s), legibly inscribed with the following information:

- a. Truck model and truck serial number.
- b. Weight of truck.
- c. Rated capacity.
- d. Designation of compliance with the mandatory requirements of ANSI/ITSDF B56.1, "Safety Standard for Low and High lift Trucks," applicable to the manufacturer.
- e. Type designation to show conformance with the requirements, such as those prescribed by Underwriters Laboratories, Inc., and Factory Mutual Research Corporation.
- f. Batteries for use in electric trucks shall have the battery weight legible stamped on the

battery tray near the lifting means as follows: Service Weight ____lb (kg).

In addition to the above requirements, additional information is required (and allowed) on nameplates on high-lift trucks, electric trucks, and trucks intended for hazardous locations (see ANSI/ITSDF B56.1, Section 7.5, "Nameplates and markings").

10.1.3.1 Fork Arm Data

For forklift trucks purchased after December 1984, each fork arm shall be clearly stamped with its rated capacity in an area readily visible and not subject to wear. For example, the designation 1500 @ 24 means 1,500-lb (680-kg) capacity at 24-in. (600-mm) load center.

10.1.4 ATTACHMENTS

Attachments almost always affect rated capacity of the truck. When a forklift truck is equipped with an attachment, the rated capacity of the truck/attachment combination shall be established by the truck manufacturer. In the event the truck manufacturer is nonresponsive, the attachment may be used if written approval is obtained from a qualified Professional Engineer. If the response from the original truck manufacturer is negative, the engineer must perform a safety analysis and address all safety and/or structural issues contained in the manufacturer's disapproval. Capacity, operation, and maintenance instruction plates, tags, or decals shall be changed accordingly.

- a. The rated capacity of an attachment/truck combination shall not be exceeded.
- b. On every removable attachment (excluding fork extensions), a corrosion-resistant nameplate with the following information is required:
 1. Model number
 2. Serial number on hydraulically actuated attachments
 3. Maximum hydraulic pressure (on hydraulically actuated attachments)
 4. Weight

- 5. Capacity
- 6. The following instructions (or equivalent); "Capacity of truck and attachment combination may be less than capacity shown on attachment. Consult truck nameplate."

equipped with additional sound-producing or visual devices (such as lights or blinkers), and shall be responsible for providing and maintaining such devices. Backup or motion alarms that sound continuously may be warranted in special cases but generally are less effective than operator-controlled devices.

10.1.5 MODIFICATIONS

- a. Modifications or additions that affect capacity or safe operation shall not be performed without prior written approval from the forklift truck manufacturer. Capacity, operation, and maintenance instruction plates, tags, or decals shall be changed accordingly.
- b. In the event that the truck manufacturer is no longer in business and there is no successor to the business, the user may arrange for a modification or alteration to a forklift truck, provided however, the user shall:
 - 1. Arrange for modifications or alteration to be designed, tested, and implemented by an engineer qualified in forklift trucks and their safety;
 - 2. Maintain a permanent record of the design, test(s), and implementation of the modifications or alteration;
 - 3. Make appropriate changes to the capacity plate(s), decals, tags, and operation and maintenance manuals;
 - 4. Affix a permanent and readily visible label on the truck stating the manner in which the truck has been modified or altered together with the date of the modification or alteration, and the name of the organization that accomplished the tasks.

10.1.7 OVERHEAD GUARDS

An overhead guard is intended to offer protection to the operator from falling objects, but it cannot protect against every possible impact. Therefore, it should not be considered a substitute for good judgment and care in load handling.

- a. High lift rider trucks, including order picker trucks, shall be equipped with an overhead guard manufactured in accordance with ANSI/ITSDF B56.1, unless the following conditions are met:
 - 1. Vertical movement of the lifting mechanism is restricted to 72 in. (1800 mm) or less from the ground.
 - 2. The truck will be operated only in an area where:
 - i. The bottom of the top tiered load is not higher than 72 in. (1800 mm) and the top is not more than 120 in. (3000 mm) from the ground where tiered.
 - ii. Only stable (preferably interlocked, unitized or containerized) loads are handled.
 - iii. There is protection against falling objects from adjacent high stack areas.
- b. Rough terrain forklift trucks shall be fitted with an overhead guard manufactured in accordance with ANSI/ITSDF B56.6.

10.1.6 WARNING DEVICES

- a. Every truck shall be equipped with an operator-controlled horn, whistle, gong, or other sound-producing device(s).
- b. The using organization shall determine if operating conditions require the truck to be

10.1.8 FIRE HAZARD AREAS

Powered forklift trucks for operation in fire hazard areas shall be of the type recommended in ANSI/NFPA 505 ("Powered Industrial Trucks, Type Designation and Areas of Use").

10.1.9 WORK ATMOSPHERE

- a. The operation of forklift trucks may effect the concentrations of carbon monoxide and oxygen in the work location. Concentrations of these materials in the work location must meet Z-1 Limits for Air

Contaminants, Occupational Safety and Health Standards for General Industry.

- b. Where general lighting is less than 2 lumens per square foot, auxiliary directional lighting shall be provided on the truck.

Figure 10-3. Types of Trucks. (sheet 1 of 6)

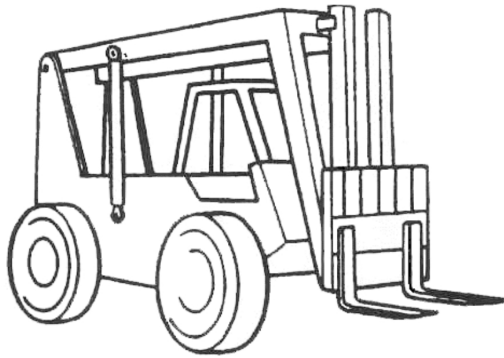

- Variable Reach Truck Linkage Type
- Four Wheel Steer
- Two Wheel Steer
- Four Wheel Drive
- Two Wheel Drive

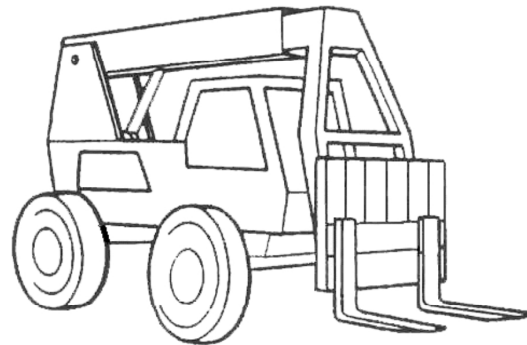

- Variable Reach Truck Boom Type
- Four Wheel Steer
- Two Wheel Steer
- Four Wheel Drive
- Two Wheel Drive



- Variable Mast
- Two Wheel Steer
- Two Wheel Drive

Figure 10-3. Types of Trucks (sheet 2 of 6)

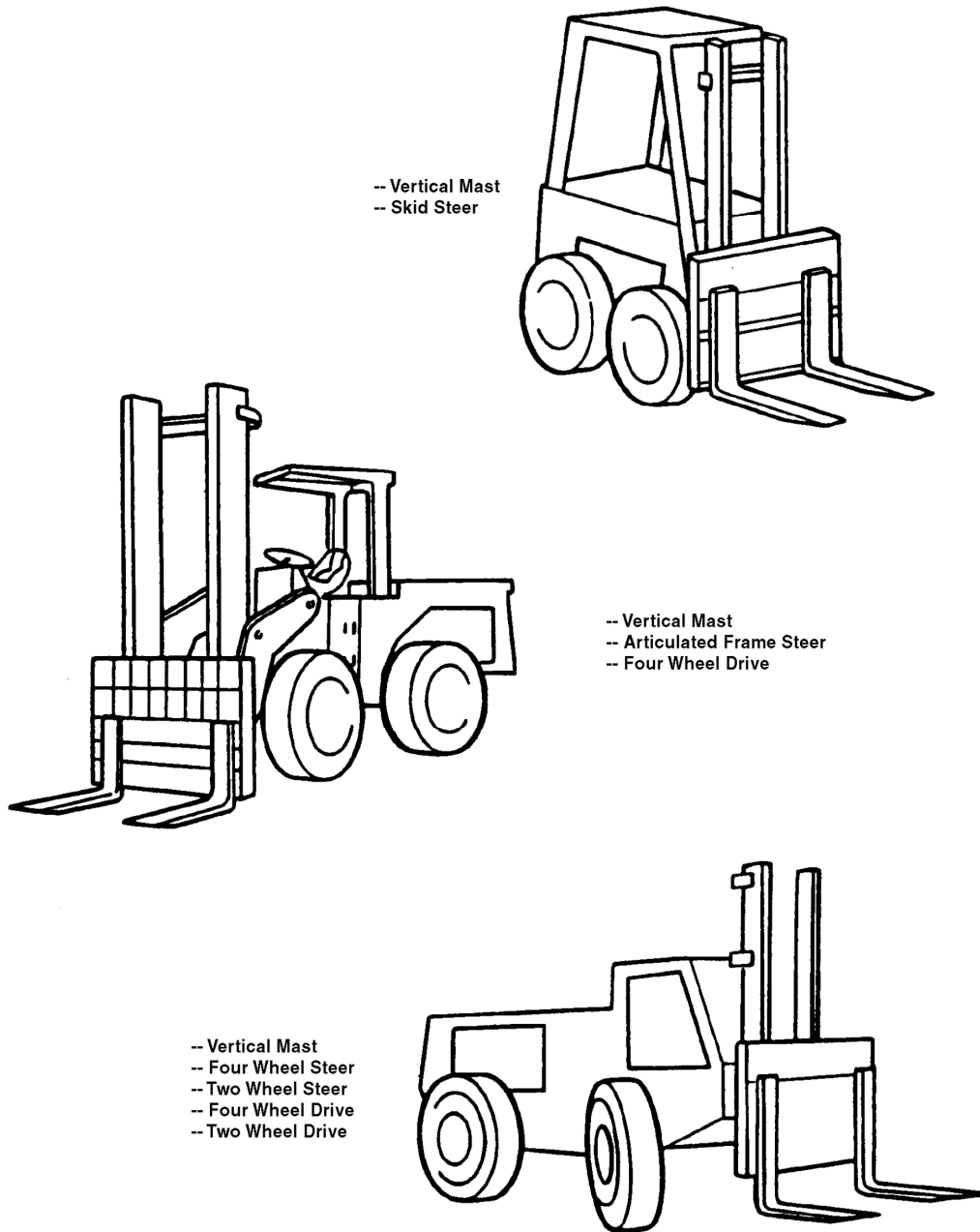
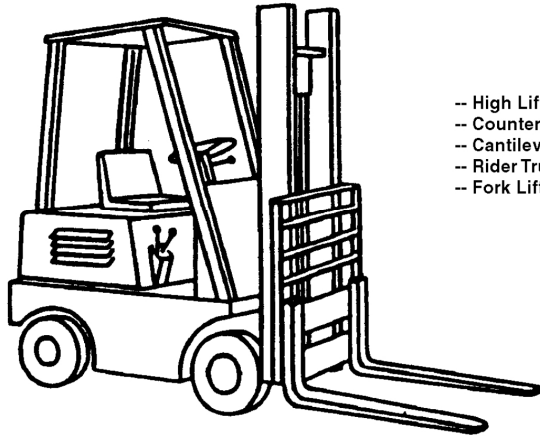
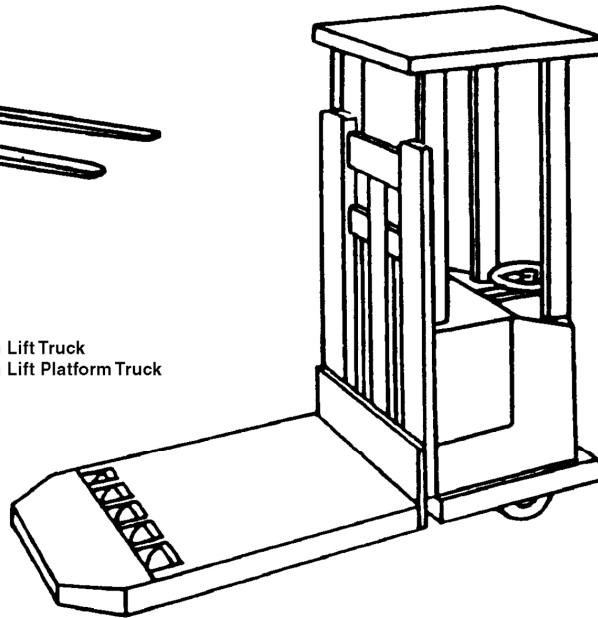

Figure 10-3. Types of Trucks (sheet 3 of 6)



- High Lift Truck
- Counterbalanced Truck
- Cantilever Truck
- Rider Truck
- Fork Lift Truck



- High Lift Truck
- High Lift Platform Truck

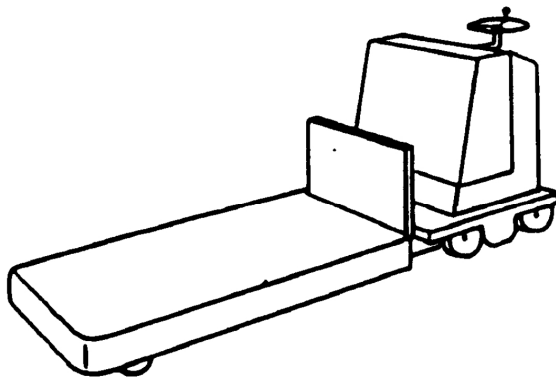

- Low Lift Truck
- Low Lift Platform Truck

Figure10-3. Types of Trucks. (sheet 4 of 6)

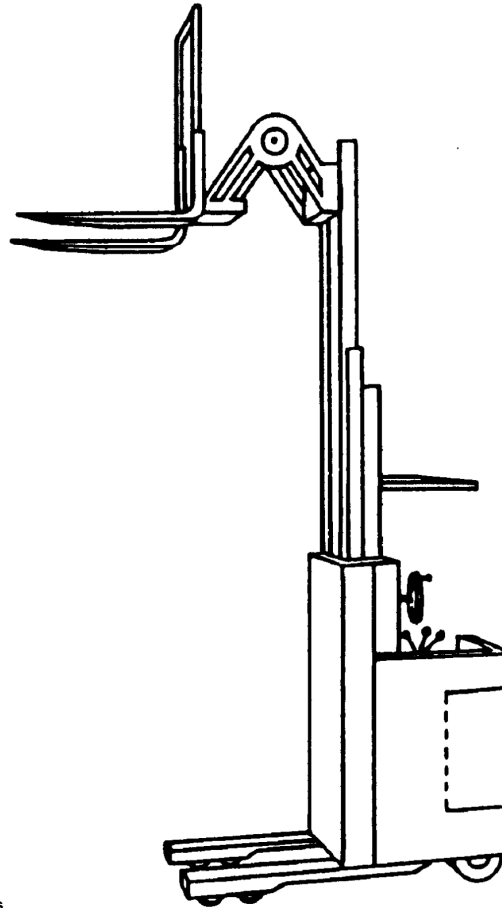

-- Reach Rider Trucks

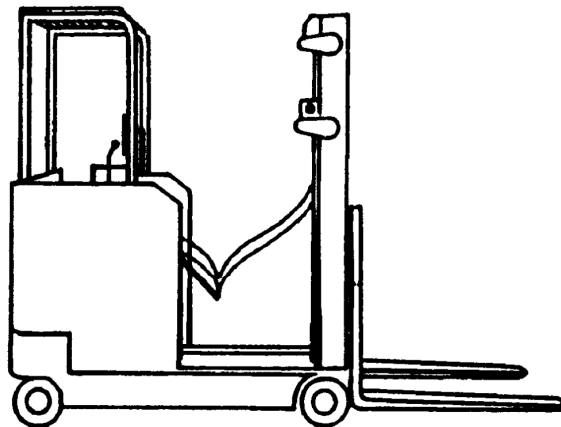

Figure 10-3. Types of Trucks. (sheet 5 of 6)

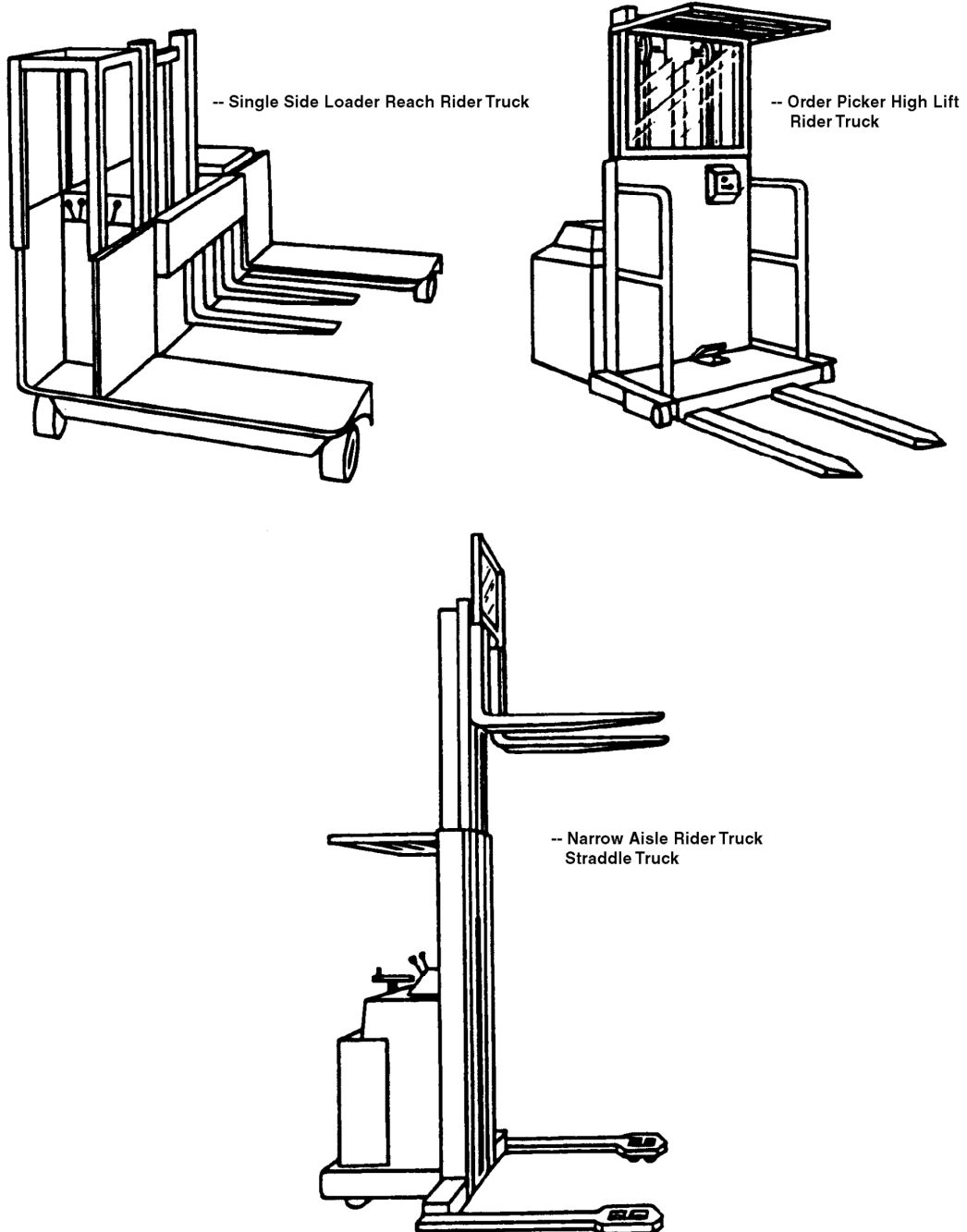
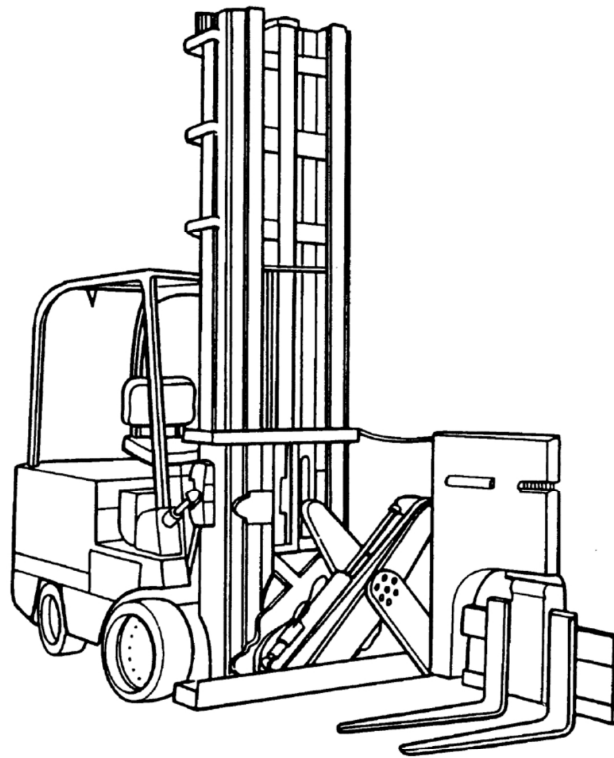
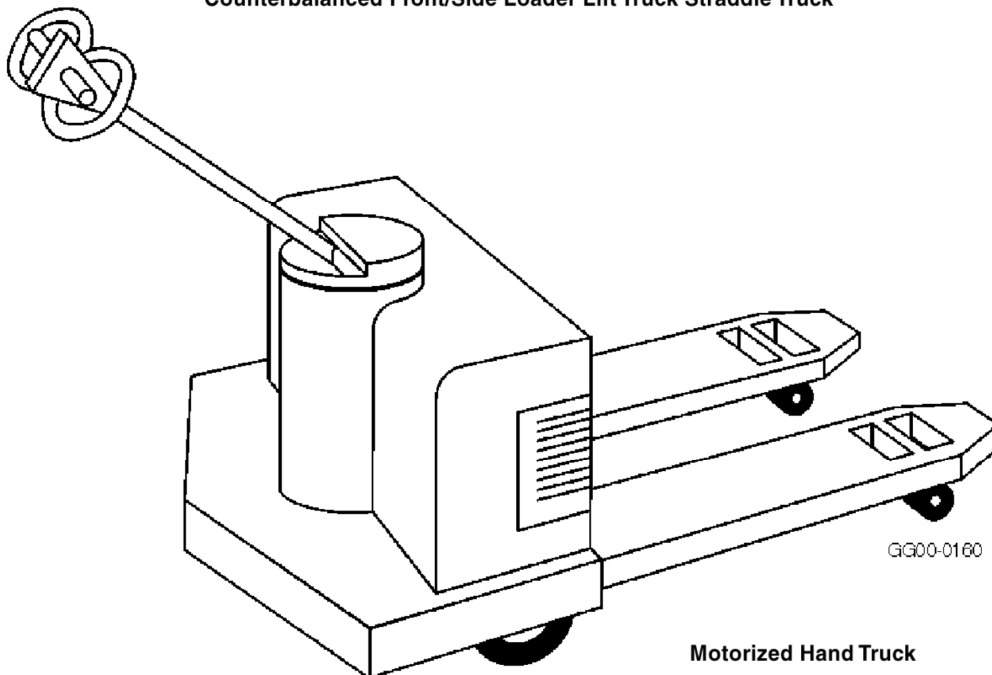

Figure 10-3. Types of Trucks (sheet 6 of 6)



Counterbalanced Front/Side Loader Lift Truck Straddle Truck



Motorized Hand Truck

Figure 10-4. Manually Operated Pallet Trucks

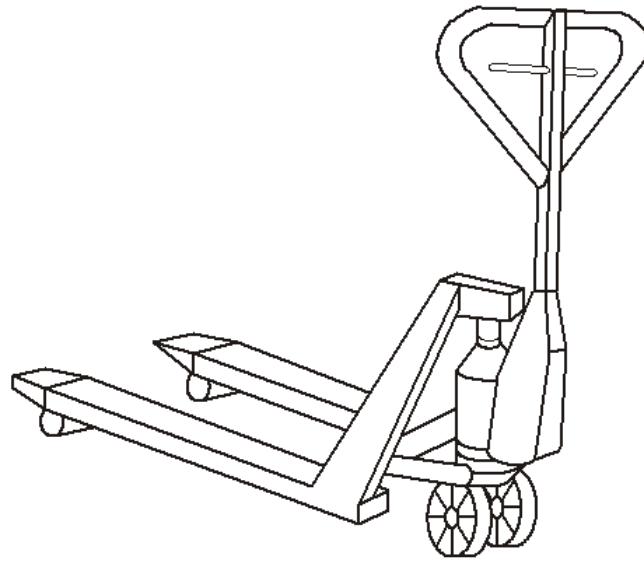

GA99 0028

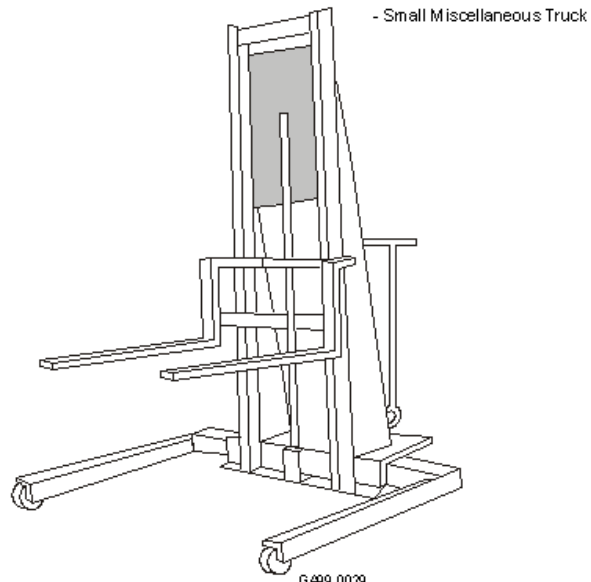

GA99 0029

10.2 TYPE DESIGNATIONS AND AREAS OF USE

10.2.1 TYPE DESIGNATION

It is essential to use proper equipment in hazardous (explosive) areas. Trucks approved for use in hazardous areas shall have the manufacturer's label or some other identifying mark indicating approval for the intended use by a recognized national testing laboratory [e.g., Underwriters Laboratories (UL or Factory Mutual (FM))].

- a. Durable markers indicating the designation of the type of truck for use in hazardous areas shall be applied to each side of the vehicle in a visible but protected area. These markers shall be distinctive in shape, as indicated in Figure 10-1.
- b. Hazardous-Area Signs. The entrance to hazardous areas shall be posted with a sign to identify the type of forklift truck permitted, see Figure 10-2, or the truck shall be clearly marked as to the area(s) it is not to enter.

10.2.1.1 Non-Hazardous Areas

The following units are not suitable for use in hazardous areas since they include only minimum safeguards against inherent fire hazards:

- a. *Type D Forklifts* – diesel-powered units having minimum acceptable safeguards against inherent fire hazards
- b. *Type E Forklifts* – electrically powered units having minimum acceptable safeguards against inherent fire and electrical shock hazards
- c. *Type G Forklifts* – gasoline-powered units having minimum acceptable safeguards against inherent fire hazards
- d. *Type LP Forklifts* – liquefied-petroleum-gas-powered units having minimum acceptable safeguards against inherent fire hazards

10.2.1.2 Hazardous Areas

The following units are suitable for use in hazardous areas since they are equipped with

additional safeguards (i.e., special exhaust, fuel, or electrical systems) or other modifications against inherent fire hazards:

- a. *Type DS Forklifts* – diesel-powered units that are provided with all the requirements for the type D units and that have additional safeguards to the exhaust, fuel, and electrical systems
- b. *Type DY Forklifts* – diesel-powered units that have all the safeguards of the type DS units except that they do not have any electrical equipment, including ignition; they are equipped with temperature-limitation features
- c. *Type ES Forklifts* – electrically powered units that are provided with all the requirements for the type E units and that have additional safeguards to the electrical system to prevent emission of hazardous sparks and to limit surface temperatures
- d. *Type EE Forklifts* – electrically powered units that are provided with all the requirements for the type E and ES units, and that also have electric motors and all other electrical equipment completely enclosed
- e. *Type EX Forklifts* – electrically powered units that differ from type E, ES, or EE units in that the electrical fittings and equipment are designed, constructed, and assembled so that the units may be used in atmospheres containing specifically named flammable vapors, dusts, and, under certain conditions, fibers; type EX units are specifically tested and classified for use in Class I, Group D, or for Class II, Group G locations as defined in NFPA 70, *National Electrical Code*
- f. *Type GS Forklifts* – gasoline-powered units that, in addition to all the requirements for the type G units, are provided with additional safeguards to the exhaust, fuel, and electrical systems
- g. *Type LPS Forklifts* – liquefied-petroleum-gas-powered units that, in addition to the requirements for the type LP units, are

provided with additional safeguards to the exhaust, fuel, and electrical systems

10.2.2 SPECIFIC AREAS OF USE

The atmosphere or location where the powered forklift is to be used shall be classified. Location classifications are described as follows:

- a. *Class I* – locations in which flammable gases or vapors are present or may be present in the air in quantities sufficient to produce explosive or ignitable mixtures.
- b. *Class II* – locations that are hazardous because of the presence of combustible dust.
- c. *Class III* – locations where easily ignitable fibers or filings are present but are not likely to be suspended in quantities sufficient to produce ignitable mixtures.
- d. *Unclassified* – locations not possessing atmospheres defined as Class I, II, or III locations.

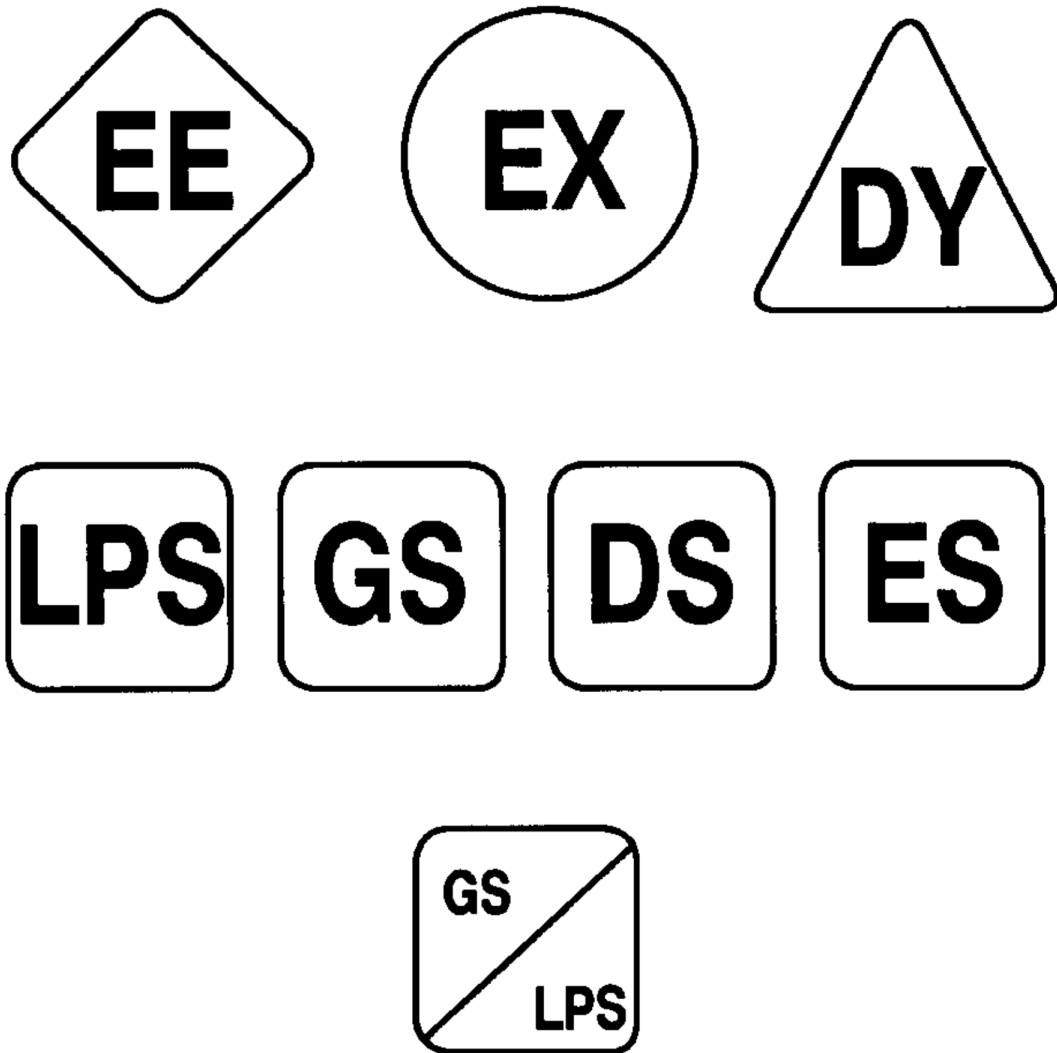

Note: The markers for EE, EX, and DY are 5 in. (12.7 cm) high. The rest are 4 in. (10 cm) square. The signs shall have black borders and lettering on a yellow background.

Figure 10-1. Markers to identify type of industrial truck.



L93 0136

Figure 10-2. Building signs for posting at entrance to hazardous areas.

NOTE: The minimum width of the sign is 11 in. (28 cm); the minimum height is 16 in. (40 cm). The sign shall have the word "caution" in yellow letters on a black background. The body of the sign shall have black letters on a yellow background. A marker identical to the one used on the side of the truck as shown in Figure 10-1, shall be installed on the sign.

10.3 INSPECTIONS

10.3.1 DAILY PRE-OPERATIONAL CHECK

- a. Instructions for pre-operational inspections shall be readily available to the operator. It is recommended that the instructions be attached to the equipment. Standard instructions will be suitable for most forklift trucks; however, operating conditions may require additional instructions. A sample Pre-operational inspection checklist is included as Exhibit 1, which appears at the end of this chapter.
- b. Before operating the truck, check its condition, giving special attention to the following:
 1. Condition of the tires
 2. Tire inflation, if pneumatic tires
 3. Warning and safety devices
 4. Lights
 5. Battery
 6. Controls
 7. Lift and tilt systems
 8. Forks or other load-engaging means
 9. Chains and cables
 10. Limit switches
 11. Brakes
 12. Steering mechanism
 13. Fuel system(s)
 14. Additional items as specified by the manufacturer or that are unique to the facility at which the truck is operated.
- c. Conditions adversely affecting safety shall be corrected before the forklift truck is placed into service.

10.3.2 INITIAL INSPECTION OF NEW AND RENTED EQUIPMENT

Prior to initial use, all new, or newly arrived rental equipment, or modified forklifts shall be inspected by a qualified inspector to ensure compliance with the provisions of this chapter. For new equipment, an initial inspection shall verify that requirements of the purchase order (or rental agreement) have been met and that the equipment is suitable for its intended use. This inspection shall be documented and should be retained in the forklift truck's history file. A sample load test and inspection form is included as Exhibit II, which appears at the end of this chapter. This form is intended to be a sample only and is not intended to be mandatory.

10.3.3 INSPECTION AND MAINTENANCE

Inspection and maintenance of powered forklift trucks shall be performed in conformance with the following practices:

- a. The inspection and maintenance program shall follow the manufacturer's recommended procedures. If equipment maintenance or inspection procedures deviate from published manufacturer's recommendations, the alternate procedures shall be approved in advance by the manufacturer or another qualified person and be kept readily available.
- b. Only trained and authorized personnel shall be permitted to inspect, maintain, repair, and adjust forklift trucks.
- c. No repairs shall be made while the truck is in a hazardous (explosive/classified) area.
- d. Inspect brakes, steering mechanisms, control mechanisms, warning devices, lights, governors, lift-overload devices, guards, and safety devices regularly and maintain them in a safe-operating condition.
- e. Carefully inspect all parts of lift and tilt mechanisms and frame members and maintain them in a safe-operating condition.

- f. Check for suspect/counterfeit parts (see Terminology and Definitions, Chapter 1).
- g. For special trucks or devices designed and approved for operation in hazardous areas, ensure that the original, approved safe-operating features are preserved by maintenance.
- h. Check fuel systems for leaks and for the proper condition of the parts. Give special consideration in the case of a fuel system leak. Take action to prevent use of the truck until the leak has been corrected.
- i. Inspect and maintain all hydraulic systems. Check tilt cylinders, valves, and other similar parts to ensure that drift or leakage has not developed to the extent that it would create a hazard.
- j. Maintain capacity, operation safety, and maintenance-instruction plates, tags, or decals in legible condition.
- k. Inspect and maintain batteries, motors, controllers, limit switches, protective devices, electrical conductors, and connections. Pay special attention to the condition of electrical insulation.
- l. Those repairs to the fuel and ignition systems of industrial trucks which involve fire hazards shall be conducted only in locations designated for such repairs.
- m. Trucks in need of repairs to the electrical system shall have the battery disconnected prior to such repairs.
- n. Water mufflers shall be filled daily or as frequently as is necessary to prevent depletion of the supply of water below 75 percent of the filled capacity. Vehicles with mufflers having screens or other parts that may become clogged shall not be operated while such screens or parts are clogged. Any vehicle that emits hazardous sparks or flames from the exhaust system shall immediately be removed from service, and not returned to service until the cause for the emission of such sparks and flames has been eliminated.
- o. When temperature of any part of any truck is found to be in excess of its normal operating temperature, the vehicle shall be removed from service and not returned to service until the cause for such overheating has been eliminated.
- p. Industrial trucks originally approved for the use of gasoline for fuel may be converted to liquefied petroleum gas fuel provided the complete conversion results in a truck which embodies the features specified for LP or LPS designated trucks. Conversion equipment and the recommended method of installation shall be approved by the manufacturer.
- q. All parts that require replacement shall be replaced only with parts that are equivalent, in regards to safety, to those used in the original design.
- r. Attachments shall be included in a scheduled maintenance/inspection program. Inspection steps shall be tailored for the attachment. Load-bearing components shall be examined for deformation and load-bearing welds shall be visually examined for cracks. Mechanical or hydraulic components shall be inspected and maintained in accordance with the manufacturer's instructions.
- s. Attachments shall be inspected not less than annually and the inspection should be documented.
- t. Hooks that are included as part of attachments shall be inspected as specified for hooks on cranes/hoists (see Chapter 13.0, "Load Hooks").

10.3.4 FORKS

10.3.4.1 Fork Load Rating

Forks used in pairs (the normal arrangement) shall have a rated capacity of each fork at least half the manufacturer's truck rated capacity at the center distance shown on the forklift truck nameplate.

10.3.4.2 Fork Inspections

- a. Forks in use (single shift operation) shall be inspected at intervals of not more than 12 months or whenever any defect or

permanent deformation is detected. Severe use applications require more frequent inspection at an interval set by facility management.

- b. Fork inspection shall be carried out by a qualified inspector with the aim of detecting any damage, failure, deformation, or other condition that might impair safe use. A fork that shows any of the following defects shall be withdrawn from service, and shall not be returned to service until it is satisfactorily repaired by the fork manufacturer or an expert of equal competence. Fork inspection shall include:

1. *Surface Cracks* – A thorough visual examination for cracks and, if considered necessary, non-destructive crack detection, with special attention to the heel and to the welds that attach the mounting components to the fork blank. Inspection for cracks shall include any mounting mechanisms of the fork blank to the fork carrier. Forks shall not be returned to service if surface cracks are detected.
2. *Fork Tine Inspection* – Examination for straightness of blade and shank, fork angle (upper face of blade to load face of the shank), fork blade and shank wear. Difference in height of fork tips may vary from manufacturer to manufacturer and with tine length. For these reasons, fork tine inspections shall be done in accordance with manufacturers requirements.
3. *Positioning Lock* – Confirm that the Positioning Lock (when provided) is in good repair and in correct working order. If any fault is found, the fork shall be withdrawn from service until satisfactory repairs are made.
4. *Fork Hooks Wear* – When fork hooks are provided, the support face of the top hook and the retaining faces of both hooks shall be checked for wear, crushing, and other local deformations. If clearance between the fork and the fork carrier becomes excessive, the fork shall not be returned to service until repaired in accordance with paragraph 10.3.4.3.

5. *Fork Marking* – When fork marking is not clearly legible, it shall be renewed. Marking shall be renewed per instructions from the original fork supplier.

10.3.4.3 Fork Repair

Only the manufacturer of the fork or an expert of equal competence shall decide if a fork may be repaired for continued use, and the repairs shall only be carried out by such authorities. Surface cracks or wear should not be repaired by welding. When resetting repairs are required, the fork shall be subject to heat treatment.

10.3.5 BATTERY MAINTENANCE

- a. Facilities shall be provided for flushing and neutralizing spilled electrolyte, for fire protection, for protecting charging apparatus from damage by trucks, and for adequate ventilation for dispersal of fumes from gassing batteries.
- b. A conveyor, overhead hoist, or equivalent material handling equipment shall be provided for handling batteries.
- c. Reinstalled batteries shall be properly positioned and secured in the truck.
- d. A carboy tilter or siphon shall be provided for handling electrolyte.
- e. When introducing electrolyte into batteries, acid shall be poured into water; water shall not be poured into acid.
- f. Trucks shall be properly positioned and brake applied before attempting to change or charge batteries.
- g. Care shall be taken to assure that vent caps are functioning. The battery (or compartment) cover(s) shall be open to dissipate heat.
- h. Smoking shall be prohibited in the charging area.
- i. Precautions shall be taken to prevent open flames, sparks or electric arcs in battery charging areas.

- j. Tools and other metallic objects shall be kept away from the top of uncovered batteries.

10.3.6 HISTORY FILE

A history file should be maintained for each forklift truck. The history file should contain information necessary to operate, maintain, test, and evaluate the forklift truck. A typical history file would contain the following types of documentation, as applicable:

- a. Manufacturer's operation and maintenance manuals.
- b. Waivers applicable to the forklift truck.
- c. Documentation for replacement forks.

- d. Documentation from the manufacturer authorizing modifications to the forklift truck.
- e. Inspection procedures and inspections records.
- f. Records of repair, modification, and overhaul.
- g. Fork inspection records, including record of fork repair.
- h. Authorization from truck manufacturer to use specifically identified attachments.

NOTE: For forklift trucks on rental, ensure that a suitable maintenance and inspection program is established for the duration of the rental period. For rental equipment onsite for 6 months or less, a history file is not recommended.

10.4 TESTING

10.4.1 FORKLIFT TRUCK LOAD TEST

Forklift truck load tests are not routinely required.

- a. Load tests shall not be conducted until verification that inspection and maintenance is up to date.
- b. Load tests shall be performed after major repair or modification to components that affect the load-carrying ability of the truck.
- c. The manufacturer should be consulted if questions arise as to whether a load test is appropriate.
- d. Forklift trucks shall be load tested by or under the direction of a qualified person and in accordance with the manufacturer's recommendations.
- e. Test weights shall be accurate within -5% , $+0\%$ of stipulated values.
- f. After a load test is performed, a written report shall be furnished by the qualified

person that shows test procedures, and confirms the adequacy of repairs or alterations. Test reports shall be retained in the truck's history file.

10.4.2 FORK LOAD TEST

A fork that has undergone repair, other than repair or replacement of positioning locks or marking, shall be subject to a load test as described in ANSI/ITSDF B56.1, Section 7.27, "Forks," Item 3, which lists loading and method of test for forks; except for the test load, which shall correspond to 250 percent of the rated capacity marked on the fork.

10.4.3 ATTACHMENT LOAD TEST

- a. Load capacity of an attachment shall be verified by the manufacturer or by a load test at 100 percent capacity that is performed onsite. Load tests are not routinely required since a catalog cut, user's manual, decals on attachment, or other manufacturer's data serves as capacity verification.

10.5 OPERATIONS

The following shall apply to all personnel involved in forklift operations. At the initial stage of the planning process, an appointed person shall classify each lift into one of the DOE-specified categories (ordinary, critical, or preengineered production).

10.5.1 CONDUCT OF OPERATOR

The following requirements shall be observed by the operator when operating forklift trucks.

10.5.1.1 General

- a. Safe operation is the responsibility of the operator. Report all accidents and “near misses” promptly.
- b. The operator shall develop safe working habits and also be aware of hazardous conditions in order to protect himself, other personnel, the truck, and other material.
- c. The operator shall be familiar with the operation and function of all controls and instruments before operating the truck.
- d. Before operating any truck, the operator shall be familiar with unusual operating conditions which may require additional safety precautions or special operating instructions.
- e. Be certain the truck has successfully passed a preuse inspection.
- f. Do not start or operate the truck, any of its functions or attachments, from any place other than from the designated operator’s position.
- g. Keep hands and feet inside the operator’s designated area or compartment. Do not put any part of the body outside the operator compartment of the truck.
- h. Never put any part of the body within the reach mechanism of the truck or other attachments.
- i. Avoid reaching through the mast for any purpose.
- j. To safeguard pedestrians, understand the truck’s limitations and observe the following precautions:
 - 1. Do not drive a truck up to anyone standing in front of an object.
 - 2. Ensure that personnel stand clear of the rear swing area before conducting turning maneuvers.
 - 3. Exercise particular care at cross aisles, doorways, and other locations where pedestrians may step into the path of travel of the truck.
 - 4. Do not allow anyone to stand or pass under the elevated portion of any truck, whether empty or loaded.
- k. Do not permit passengers to ride on powered industrial trucks unless a safe place to ride has been provided by the manufacturer.
- l. Ensure that fire aisles, access to stairways, and fire equipment is kept clear.
- m. A powered industrial truck is considered unattended when the operator is more than 25 ft. (7.6 m) from the truck, which remains in his view, or whenever the operator leaves the truck and it is not in his view.
- n. Before leaving the operator’s position, the operator shall perform the following:
 - 1. Bring truck to a complete stop.
 - 2. Place directional controls in neutral.
 - 3. Apply the parking brake.
 - 4. Fully lower load-engaging means, unless supporting an elevated platform.
- o. In addition, when leaving the truck unattended the operator shall perform the following:
 - 1. Stop the engine or turn off the controls.
 - 2. If the truck must be left on an incline, block the wheels.

3. Fully lower the load-engaging means.
- p. Maintain a safe distance from the edge of ramps, platforms, and other similar working surfaces. Do not move railroad cars with a powered industrial truck.
- q. Do not use a truck for operating or closing railroad car doors except as follows:
1. Unless the truck utilizes a device specifically designed for opening and closing railroad car doors and the operator is trained in its use.
 2. The design of the door-opening device shall require the truck to travel parallel to the railroad car, with the force applied in a direction parallel with the door travel.
 3. Care should be exercised when engaging the railroad car door with the door opening device, in order to prevent damage to the doors and/or fork truck by heavy impact forces.
 4. The entire door opening operation shall be in full view of the operator.
 5. The fork truck shall always be positioned to safeguard the dock attendant while removing the door lock pin.
 6. Whenever a railroad car door requires an abnormal force to open, the truck operator shall report the condition to his supervisor.
- r. Wheel stops, hand brakes, or other recognized positive protection shall be provided to prevent railroad cars from moving during loading or unloading operations.
- s. Consider both the truck and load weight when operating in railcars and semitrailers.
- t. Inspect floors on trucks, boxcars, unfamiliar ramps, or platforms before start of operation.
- u. Other workers should not be inside the truck when the forklift truck is performing loading or unloading operations. Load arrangements and spacing issues should be determined before the forklift enters the truck.
- v. Fixed jacks or supports may be needed to prevent upending or corner dipping when powered industrial trucks are driven on and off semitrailers that are not coupled to the tractor.
- w. The brakes of highway trucks shall be set and wheel chocks placed under the rear wheels to prevent the trucks from rolling while they are boarded.
- x. Care shall be taken to not contact overhead installations such as lights, wiring, pipes, sprinkler systems, etc. If in doubt, measure.
- y. Motorized hand trucks shall not be ridden unless they are of the hand/rider design.

10.5.1.2 Traveling

- a. Observe all traffic regulations and under all travel conditions, operate the truck at a speed that will permit it to be brought to a stop in a safe manner. Unless facility-specific procedures state otherwise, the guideline is: within plant buildings – 5 mph; on plant roads – 15 mph. Drive slowly around curves.
- b. Yield the right of way to pedestrians and emergency vehicles. Whenever possible, establish eye contact with approaching pedestrians or vehicle drivers before continuing.
- c. Do not pass another truck traveling in the same direction at intersections, blind spots, or at other locations where vision is obstructed.
- d. Slow down and sound horn at cross aisles and other locations where vision is obstructed.
- e. Railroad tracks shall be crossed diagonally whenever possible.
- f. Never travel with forks raised to unnecessary heights. Approximately 4 to 6 inches (10 to 15 cm) above floor level is adequate.

- g. Do not park closer than 6 ft (1800 mm) to the nearest rail or a railroad track.
- h. Face in the direction of travel, except if the load being carried obstructs forward view. In such cases, travel with the load trailing.
- i. When ascending or descending grades, ramps, and inclines:
 - 1. In excess of 5 percent grade, drive loaded rider trucks with the load upgrade.
 - 2. Use low gear or slowest speed control.
 - 3. Operate unloaded trucks with the load-engaging means downgrade.
 - 4. The load and load-engaging means shall be tilted back, if applicable and raised only as far as necessary to clear the road surface.
 - 5. Avoid turning if possible, and normally travel straight up and down.
- j. While turning, be cautious of rear end swing and keep clear of the edge of loading docks.
- k. Make starts, stops, turns, or direction reversals in a smooth manner so as not to shift load and/or overturn the truck.
- l. Do not indulge in stunt driving or horseplay.
- m. Slow down for wet and slippery floors.
- n. Before driving over a dockboard or bridge plate, be sure that it is properly secured.
- o. Drive carefully and slowly across the dockboard or bridge plate, and never exceed its rated capacity.
- p. Do not drive trucks onto any elevator unless specifically authorized to do so. In cases where operation is authorized:
 - 1. Do not exceed the capacity of the elevator.
 - 2. Approach elevators slowly, and then enter squarely after the elevator car is properly leveled.
- 3. Once on the elevator, neutralize the controls, shut off the power, and set brakes.
- 4. It is advisable that all other personnel leave the elevator before truck is allowed to enter or leave.
- q. Unless a towing hitch is supplied by the manufacturer, do not use forklift trucks as tow trucks. When a towing hitch is provided, use tow bars rather than wire rope for towing.
- r. At the end of the operator's shift, return the forklift truck to its assigned parking place, set brakes, fully lower load-engaging means, place controls in neutral position, turn ignition off, and secure the key.
- s. If the truck is equipped with a seat belt, use it.

10.5.1.3 Loading

- a. Since the load rating for forklifts may be based on stability or hydraulic or structural competence, do not exceed the rated capacity in operational application.
- b. The designated person shall ensure that the weight of a load approaching the rated capacity (combination of weight and location of the center of gravity) has been determined within -10 percent, +0 percent before it is lifted.
- c. Only stable, safely arranged loads shall be handled. Block and secure them if necessary.
- d. Caution shall be exercised when handling off-center loads which cannot be centered.
- e. Always spread the forks to suit the load width.
- f. Extra caution is required when handling loads exceeding the dimensions used to establish truck capacity. Stability and maneuverability may be adversely affected.
- g. The forks shall be placed under the load as far as possible; the mast shall be carefully tilted backward to stabilize the load.

- h. Do not transport loads or miscellaneous items within the operator's compartment or other areas of the truck, unless a secure area has been provided and designated by the user.
- i. A load backrest extension shall be used whenever necessary to minimize the possibility of the load or part of it from falling rearward.
- j. Do not attach or operate any attachment on a forklift truck that has not been approved for use by forklift truck manufacturer or a qualified engineer in the absence of manufacturer approval.
- k. When attachments are used, extra care shall be taken in securing, manipulating, positioning, and transporting the load.
- l. Operate trucks equipped with attachments as partially loaded trucks when not handling a load.
- m. Fork length should be at least two thirds of the load length.
- n. Use extreme care when tilting load forward or backward, particularly when high tiering.
- o. Do not tilt forward with forks elevated except to pick up or deposit a load over a rack or stack.
- p. When stacking or tiering, use only enough backward tilt to stabilize the load.
- q. Rigging loads from the tines of a forklift, (attaching rigging to the forks to support a suspended load) shall only be performed by qualified personnel in accordance with approved site procedures.
- r. Never lift with one fork without an engineering analysis and approval.
- s. Use guides and signalers as necessary. If in doubt, check the conditions personally before proceeding. Standard hand signals are shown in Figure 10.5, "Hand Signals."
- t. Do not block fire extinguishers, fire protection sprinklers, or alarm stations when stacking loads.

10.5.2 LIFTING OF PERSONNEL

Only the operator-up high lift trucks have been designed to lift personnel. If a work platform is used on forklift trucks designed and intended for handling materials, take the following precautions:

- a. Use a lift platform manufactured for the purpose of lifting personnel with a forklift truck. The platform shall include:
 1. A 4 in. (10 cm) minimum height toe plate provided on the work platform.
 2. The floor of the platform located not more than 8 in. (20 cm) above the upper face of the supporting truck fork blade.
 3. A restraining means such as a guard rail having a height above the platform floor of not less than 36 in. (90 cm) or more than 42 in. (110 cm) around its upper periphery and including a midrail.
 4. An access opening in the guard rail may be hinged or removable, or chains may be used if proper positioning is easily accomplished and secured condition is discernible.
 5. Guard rails and access openings shall be capable of withstanding a concentrated force of 200 lb (91 kg) in any direction.
 6. Means to securely attach the platform to the lifting carriage or forks in such a manner that it cannot slide or bounce off the forks.
 7. Means to correctly locate the platform centered laterally on the truck.
 8. Floor dimensions that neither exceed two times the load center distance listed on the truck nameplate, measured parallel to the longitudinal center plane of the truck, nor have a width greater than the overall width of the truck (measured across the load bearing tires) plus 10 in. (25 cm) on either side.
 9. The following information should be prominently indicated on the platform:

- i. Maximum load including personnel and equipment;
 - ii. Weight of empty platform;
 - iii. Minimum capacity of the truck on which the platform can be used.
- b. The combined weight of the platform, load, and personnel shall not exceed one-half of the capacity as indicated on the nameplate of the truck on which the platform is used.
- c. Whenever a truck (except for high-lift order-picker trucks) is equipped with vertical hoisting controls elevatable with the lifting carriage or forks, take the following additional precautions to protect personnel:
1. Means shall be provided whereby personnel on the platform can shut off power to the truck.
 2. Means shall be provided to render inoperative all operating controls on the elevating platform, when the controls on the elevating platform have been selected for use; only one location of controls shall be capable of being operated at one time.
 3. Emergency-lowering means available at ground level should be provided; such means shall be protected against misuse.
- d. Take the following precautions whenever personnel are elevated with a forklift truck:
1. Ensure the truck has a firm and level footing.
 2. Place all travel controls in neutral and set parking brake.
 3. Before elevating personnel, mark area with cones or other devices to warn of work by elevated personnel.
 4. Lift and lower personnel smoothly, with caution, and only at their request.
 5. Avoid overhead obstructions and electric wires.
 6. Keep hands and feet clear of controls other than those in use.
 7. Move truck and/or platform slowly, only for minor adjustments in horizontal positioning when personnel are on the platform, and only at their request.
 8. Ensure the mast is vertical – do not operate on a side slope.
 9. The platform is horizontal and never tilted forward or rearward when elevated.
 10. Personnel are to remain on the platform floor. The use of railings, planks, ladders, etc., on the platform for the purpose of achieving additional reach or height is prohibited.
 11. Ensure personnel and equipment on the platform do not exceed the available space.
 12. Lower platform to floor level for personnel to enter and exit. Do not climb on any part of the truck in attempting to enter or exit.
 13. The operator shall remain in the control position of the forklift truck.
 14. Be certain that the lifting mechanism is operating smoothly throughout its entire lift height, both empty and loaded, and that lift limiting devices and latches, if provided, are functional.
 15. Means shall be provided to protect personnel from moving parts of the forklift truck that present a hazard when the personnel platform is in the normal working position.
 16. Overhead protection, as necessary for operating conditions, shall be provided.
 17. Do not transport personnel from one location to another while they are on the work platform.
 18. When not in the operating position, engage the parking brake and block the wheels.

19. Be certain that required restraining means such as railings, chains, cable, body belts with lanyards, or deceleration devices, etc., are in place and properly used.

10.5.3 STANDARD HAND SIGNALS

- a. Standard hand signals for use at DOE locations shall be as specified in the latest edition of the ANSI standards for the particular forklift being used (see Figure 10-5).
- b. The operator shall recognize signals only from the designated signaler. *However Obey a STOP signal no matter who gives it.*
- c. For operations not covered by standard hand signals, special signals shall be agreed on in advance by both the operator and the signal person, and should not conflict with the standard signals.

10.5.4 ORDINARY LIFTS

- a. The requirements of all preceding paragraphs in Section 10.5, "Operation," shall also apply to ordinary lifts.
- b. Ordinary lifts involving hoisting and rigging operations require a designated leader who shall be present at the lift site during the entire lifting operation. If the lift is being made by only one person, that person assumes all responsibilities of the designated leader.
- c. Leadership designation may be by written instructions, specific verbal instructions for the particular job, or clearly defined responsibilities within the crew's organizational structure. The designated leader's responsibility shall include the following:
 1. Ensuring that personnel involved understand how the lift is to be performed.
 2. Ensuring that the weight of the load is determined, that proper equipment and accessories are selected, and that rated capacity is not exceeded.

3. Surveying the lift site for hazardous/unsafe conditions.
4. Ensuring that equipment is properly set up and positioned.
5. Ensuring that a signaler is assigned, if required, and is identified to the operator.
6. Directing the lifting operation to ensure that the job is performed safely and efficiently.
7. Stopping the job when any potentially unsafe condition is recognized.
8. Directing operations if an accident or injury occurs.



10.5.5 CRITICAL LIFTS

See Chapter 2, "Critical Lifts," for critical-lift requirements.

10.5.6 EQUIPMENT QUALIFICATION

To qualify for operation, a forklift truck should have the following:

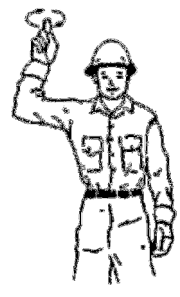
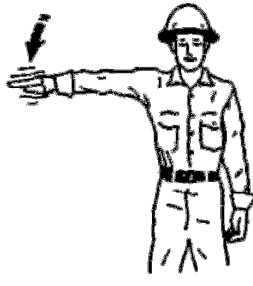
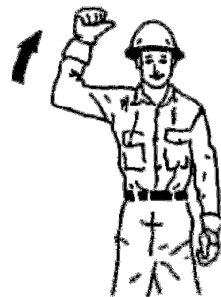
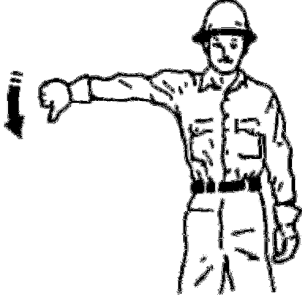
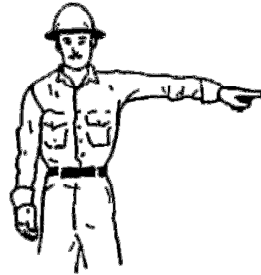
- a. A record of successful inspections and maintenance.
- b. A frequent (preuse) inspection instruction available to the operator.
- c. A qualified operator.
- d. Proper type designation for working in a classified hazardous area, if applicable.

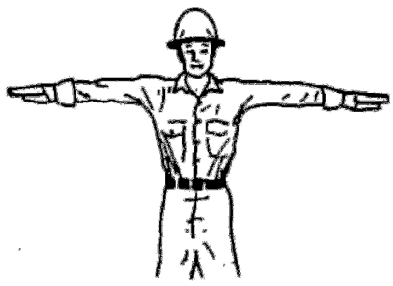
 <p>RAISE THE TINES. With forearm vertical, forefinger pointing up, move hand in small horizontal circle.</p>	 <p>LOWER THE TINES. With arm extended, palm down, lower arm vertically.</p>	 <p>TILT MAST BACK. With forearm vertical, thumb extended, jerk thumb over shoulder.</p>
 <p>TILT MAST FORWARD. With arm extended, thumb down, lower arm vertically.</p>	 <p>MOVE TINES IN DIRECTION FINGER POINTS. With arm extended, palm down, point forefinger in direction of movement.</p>	 <p>DOG EVERYTHING. Clasp hands in front of body.</p>
 <p>STOP. Extend both arms, palms down.</p>		

INTENTIONALLY BLANK

Exhibits I and II are intended to be sample forms only.
The equipment manufacturer's inspection/testing
criteria supercede any other criteria.
In cases where the equipment manufacturer does not include
inspection/testing criteria, other forms developed to facilitate
required inspection/testing are acceptable.

INTENTIONALLY BLANK

EXHIBIT I
(SAMPLE FORM ONLY)

Typical Preuse Inspection Procedures (sheet 1 of 2).
OPERATORS PRE-SHIFT INSPECTION
(ELECTRIC FORKLIFT)

Date: _____ Vehicle No.: _____ Shift: _____
Type and Model _____ Hour Meter _____

OK	NA	VISUAL CHECKS	Maintenance Needed – Reported to:
		Leaks – Hydraulic Oil, Battery	
		Tires – Condition and pressure	
		Forks, Top Clip retaining pin and heel - Condition	
		Load Backrest Extension – solid attachment	
		Hydraulic hoses, Mast chains & Stops	
		Finger guards – attached	
		Safety warnings – attached and legible	
		Operators manual – Located on truck and legible	
		Capacity Plate – attached; information matches Model & Serial Nos. and attachments	
		Seat Belt – Buckle and retractor working smoothly	
OPERATIONAL CHECKS – Unusual Noises Must be Reported Immediately			
		Accelerator Linkage	
		Parking Brake/Deadman	
		Steering	
		Drive Control – Forward and Reverse	
		Tilt Control – Forward and Back	
		Hoist & Lowering Control	
		Attachment Control	
		Horn	
		Lights	
		Back-Up Alarm	
		Hour Meter	
		Battery Discharge Gauge	

Daily Pre-Shift Inspections are an OSHA requirement. We recommend that you document that these inspections have been made.

Inspected by: _____

Custodian: _____

EXHIBIT I
(SAMPLE FORM ONLY)

Typical Preuse Inspection Procedures (sheet 2 of 2).
OPERATORS PRE-SHIFT INSPECTION
(GAS, LP, or DIESEL FORKLIFT)

Date: _____ Vehicle No.: _____ Shift: _____
Type and Model: _____ Hour Meter: _____

OK	NA	VISUAL CHECKS	Maintenance Needed – Reported to:
		Fluid Levels – Oil, Radiator, Hydraulic	
		Leaks – Hydraulic Oil, Battery, Fuel	
		Tires – Condition and pressure	
		Forks, Top Clip retaining pin and heel – Condition	
		Load Backrest Extension – solid attachment	
		Hydraulic hoses, Mast chains & Stops	
		Finger guards – attached	
		Safety warnings – attached and legible	
		Operators manual – Located on truck and legible	
		Capacity Plate – attached; information matches Model & Serial Nos. and attachments	
		Seat Belt – Buckle and retractor working smoothly	
OPERATIONAL CHECKS – Unusual Noises Must be Reported Immediately			
		Accelerator Linkage	
		Parking Brake	
		Steering	
		Drive Control – Forward and Reverse	
		Tilt Control – Forward and Back	
		Hoist & Lowering Control	
		Attachment Control	
		Horn	
		Lights	
		Back-Up Alarm	
		Hour Meter	

Daily Pre-Shift Inspections are an OSHA requirement. We recommend that you document that these inspections have been made.

Inspected by: _____

Custodian: _____

**EXHIBIT II
(SAMPLE FORM)**

FORKLIFT LOAD TEST

INSPECTED BY: _____ EQUIPMENT NUMBER: _____

LOCATION: _____ DATE: _____

INSPECTION: Forklifts shall be inspected when assigned to service and at least every 12 months thereafter.

Prior to initial use, all new, modified, or extensively repaired forklifts shall be inspected.

Craftsmen shall initial all tests, work, and inspections completed below.

Qualified inspector shall verify inspections have been complete prior to load test.

CRAFTSMAN
INITIAL

- _____ 1. Ensure capacity, operation, and maintenance-instruction plates, tags, or decals are legible.
- _____ 2. Check all hydraulic systems including tilt cylinders, valves, and other similar parts to ensure "drift" has not developed.
- _____ 3. Check fuel system for leaks and condition of parts. Special consideration shall be given in the case of a leak in the fuel system. Immediate action shall be taken to take the forklift out of service until the leak is corrected.
- _____ 4. Check all parts of lift and tilt mechanisms and frame members to ensure safe operating conditions, such as, but not limited to, hoist chain for damage and excessive wear.
- _____ 5. Check for proper tire inflation (where applicable). Check that tires are secured properly and are level with each other.
- _____ 6. Check batteries, motors, controllers, limit switches, protective devices, electrical conductors and connections, with special attention paid to the condition of electrical insulation.
- _____ 7. Check brakes, steering mechanisms, warning devices, lights, governors, lift overload devices, guards, and safety devices.

Qualified inspector shall use the criteria for Items 8, 9, and 10 to perform visual examination; or as required by the manufacturer, liquid penetrant examination, or magnetic particle examination.

Acceptance: No cracks, linear indications, laps, or seams.

- _____ 8. Check for forks being secured properly and level with each other.
- _____ 9. Performs nondestructive test (NDT) on the right angle joint of the fork once every 12 months.
- _____ 10. Performs NDT on the load or stress-bearing welds that attach the tines to the forklift once every 12 months.

EXHIBIT II (continued)

FORKLIFT LOAD TEST

LOAD TEST

- NOTES:
1. Read all steps below prior to load test.
 2. Forklifts in which load-sustaining parts have been altered, replaced, or repaired shall be load tested prior to initial use.
 3. Load test all forklifts at 100% rated capacity.

QUALIFIED INSPECTOR: Shall verify all steps below.

EQUIPMENT NUMBER _____ EQUIPMENT OPERATOR _____

Qualified Inspector Verify (Load Test) _____ Date _____

Weight _____

1. Set forklift on solid, level ground.
2. Perform load test using the required weight (see Note 3).
3. Static Test: Forklift trucks shall demonstrate ability to withstand the appropriate test load for a period of at least 10 min without permanent deformation or apparent damage. Load slippage for this equipment shall not be greater than a maximum of 3 in. vertically and 1 in. horizontally at the cylinder.
4. Check system for leaks while undergoing test.