

FCC TEST REPORT

REPORT NO.:SE07FCI099R

MODEL NO.: SHF20

RECEIVED: Nov 27, 2007

TESTED: Nov 27, 2007 to Dec 07, 2007

APPLICANT: SEECODE GERMANY GMBH

ADDRESS: Roesrather Strasse 333, D-51107 KOLN/COLOGNE, Germany

ISSUED BY: SHENZHEN SETEK TECHNOLOGY CO., LTD.

LAB LOCATION: 2/F,A3 Bldg,East Industry Zone,Overseas Chinese Town,
Shenzhen,China

This test report consists of 54 pages in total, it may be duplicated completely for legal use with the approval of the applicant, It should not be reproduced except in full, without the written approval of our laboratory, The test results in the report only apply to the tested sample.

SHENZHEN SETEK TECHNOLOGY CO., LTD.

Our website: www.setek.com.cn

TEL:86-755-26966362

E-mail:Service@setek.com.cn

FAX: 86-755-26966270

Prepared for : SEECODE GERMANY GMBH
Address : Roesrather Strasse 333, D-51107 KOLN/COLOGNE , Germany
Product : SEECODE WHEEL
Model No. : SHF20
Trademark : SEECODE
Test Standard : FCC Part 15 Paragraph 15.203, Paragraph 15.207 and Paragraph 15.247
Prepared by : SHENZHEN SETEK TECHNOLOGY CO., LTD.
Address : 2/F, A3 Bldg, East Industry Zone, Overseas Chinese Town,
Shenzhen, China

FCC Registration Number: 966959

Tel: (86-755) 26966362 Fax:(86-755) 26966270

Prepared by : 

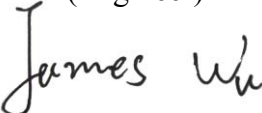
(Engineer)
Reviewer by : 

(Project Engineer)
Approved by : 

(Manager)

Report Number : SE07FCI099R
Date of Test : Nov 27, 2007 to Dec 07, 2007
Date of Report : Dec 07, 2007

The device described above is tested by SHENZHEN SETEK TECHNOLOGY CO., LTD. to determine the maximum emission levels emanating from the device and the severe levels of the device can endure and its performance criterion. This report applies to above tested sample only and shall not be reproduced in part without written approval of SHENZHEN SETEK TECHNOLOGY CO., LTD.

TABLE OF CONTENTS

Description	Page
The Report Description	
1. GENERAL INFORMATION	5
1.1. Description of Device (EUT).....	5
1.2. Description of Support Device.....	6
1.3. Summary of test results.....	6
1.4. List of Measuring Equipments Used.....	7
1.5. Test Facility	7
1.6. Measurement Uncertainty.....	7
2. ANTENNA REQUIREMENT	8
2.1. Standard Applicable.....	8
2.2. Antenna Connected Construction	8
3. POWER LINE CONDUCTED MEASUREMENT	9
3.1. Test Equipment.....	9
3.2. Block Diagram of Test Setup.....	9
3.3. Power Line Conducted Emission Measurement Limits(Class B).....	9
3.4. Configuration of EUT on Measurement	10
3.5. Operating Condition of EUT	10
3.6. Test Procedure	10
3.7. Power Line Conducted Emission Measurement Results	10
4. TEST OF HOPPING CHANNEL BANDWIDTH	11
4.1 Applicable Standard.....	11
4.2 EUT Setup.....	11
4.3 Test Equipment List and Details	11
4.4 Test Procedure.....	11
4.5 Test Result.....	11
5. TEST OF HOPPING CHANNEL SEPARATION	15
5.1 Applicable Standard	15
5.2 EUT Setup.....	15
5.3 Test Equipment List and Details	15
5.4 Test Procedure.....	15
5.5 Test Result.....	15
6. TEST OF NUMBER OF HOPPING FREQUENCY	19
6.1 Applicable Standard	19
6.2 EUT Setup.....	19
6.3 Test Equipment List and Details	19
6.4 Test Procedure.....	19
6.5 Test Result.....	19
7. TEST OF DWELL TIME OF EACH FREQUENCY	21
7.1 Applicable Standard	21
7.2 EUT Setup.....	21
7.3 Test Equipment List and Details	21
7.4 Test Procedure.....	21
7.5 Test Result.....	21
8. TEST OF MAXIMUM PEAK OUTPUT POWER	26
8.1 Applicable Standard	26
8.2 EUT Setup.....	26
8.3 Test Equipment List and Details	26

8.4 Test Procedure.....	26
8.5 Test Result.....	27
9. TEST OF BAND EDGES EMISSION.....	30
9.1 Applicable Standard.....	30
9.2 EUT Setup.....	30
9.3 Test Equipment List and Details.....	30
9.4 Test Procedure.....	31
9.5 Test Result.....	31
10. PEAK POWER SPECTRAL DENSITY MEASUREMENT	33
10.1 Standard Applicable.....	33
10.2 Test Equipment List and Details.....	33
10.3 Measurement Procedure.....	33
10.4 Test Result.....	34
11. TEST OF SPURIOUS RADIATED EMISSION	35
11.1 Applicable Standard.....	35
11.2 EUT Setup.....	35
11.3 Test Equipment List and Details.....	36
11.4 Test Procedure.....	36
11.5 Test Result.....	37
12. FCC ID LABEL	46
13. PHOTOGRAPH.....	47
13.1 Photo of Radiated Measurement.....	47

APPENDIX I (Compliance Statements) (2 Pages)

APPENDIX II (Photos of EUT) (3 Pages)

1. GENERAL INFORMATION

1.1. Description of Device (EUT)

Applicant : SEECODE GERMANY GMBH
Address : Roesrather Strasse 333, D-51107 KOLN/COLOGNE, Germany
Manufacturer : UNIFAT TECHNOLOGY LTD
Address : SiMa Chang Ping, Dongguan, PRC
EUT : SEECODE WHEEL
Model Number : SHF20
Description of EUT : Bluetooth Handfree
Description of Antenna : fixed, built-in antenna, -1.0dBi
Power Supply : DC 12V or 3.7 V from rechargeable battery
Operation Frequency : 2402 MHz ~ 2480 MHz
Number of Channels : 79
Type of Modulation : FHSS
Output Power Class : Class 2
Received : Nov 27, 2007
Date of Test : Nov 27, 2007 to Dec 07, 2007

1.2. Description of Support Device

PC : Manufacturer: DELL
 M/N: E157FPc
 S/N: 53SM12X
 CCC,FCC,VCCI,GS,S,CE
 Monitor : Manufacturer: SAMSUNG
 M/N: 710MP [R]S
 S/N: MH17HVY500468F
 CCC,SA,UL
 Mouse : Manufacturer: DELL
 M/N: M056UOA
 S/N: F1101WOS
 CE, VCCI,FCC,GS,UL
 Keyboard : Manufacturer: DELL
 M/N: SK-8135
 S/N: CN-0DJ340-71616683-01U6
 VCCI,CE, FCC

1.3. Summary of test results

FCC Rules	Description Of Test	Result
15.203/15.247(b)/(c)	Antenna Requirement	Pass
15.207	Conducted Emission	N/A
15.247(a)(1)	Hopping Channel Bandwidth	Pass
15.247(a)(1)	Hopping Channel Separation	Pass
15.247(a)(1)	Number of Hopping Frequency Used	Pass
15.247(a)(1)(iii)	Dwell Time of Each Frequency	Pass
15.247(b)(1)	Maximum Peak Output Power	Pass
15.247(d)	Band Edges Emission	Pass
15.247(d)	Peak Power Spectral Density	Pass
15.247(d)	Spurious Radiated Emission	Pass

1.4. List of Measuring Equipments Used

Item	Equipment	Manufacturer	Model No.	Serial No.	Last Cal.	Cal. Interval
1.	Spectrum Analyzer	Agilent	E4408B	MY44210575	May 29,2007	1 Year
2.	Test Receiver	Rohde & Schwarz	ESIB26	100234	May 29,2007	1 Year
3.	Bilog Antenna	Schwarzbeck	VULB9163	142	May 29,2007	1 Year
4.	Loop Antenna	EMCO	6502	00042960	Dec 11,2006	1 Year
5.	50 Coaxial Switch	Anritsu Corp	MP59B	6100237248	May 29,2007	1 Year
6.	Cable	Schwarzbeck	AK9513(1m)	CR RX2	May 29,2007	1 Year
7.	Cable	Schwarzbeck	AK9513(10m)	AC RX1	May 29,2007	1 Year
8.	Cable	Rosenberger	N/A(6m)	CR RX1	May 29,2007	1 Year
9.	Cable	Rosenberger	N/A(10m)	FP2RX2	May 29,2007	1 Year
9.	DC Power Filter	MPE	23872C	N/A	May 29,2007	1 Year
10.	Single Phase Power Line Filter	MPE	23332C	N/A	May 29,2007	1 Year
11.	3 Phase Power Line Filter	MPE	23333C	N/A	May 29,2007	1 Year
12.	Signal Generator	HP	8648A	3625U00573	May 29,2007	1 Year
13.	Test Receiver	Rohde & Schwarz	ESCS30	100350	May 29,2007	1 Year
14.	L.I.S.N.	Rohde & Schwarz	ESH2-Z5	834549/005	May 29,2007	1 Year
15.	Pulse Limiter	Rohde & Schwarz	ESH3-Z2	100006	May 29,2007	1 Year
16.	RF Cable	FUJIKURA	RG-55/U	LISN Cable	May 29,2007	1 Year

1.5. Test Facility

The test facility is recognized, certified, or accredited by the following organizations:

FCC – Registration No.: 966959

SHENZHEN SETEK TECHNOLOGY CO., LTD, the EMC Laboratory has been registered and fully described in a report filed with the (FCC) Federal Communications Commission.

1.6. Measurement Uncertainty

Radiation Uncertainty : $U_r = \pm 3.84\text{dB}$

Conduction Uncertainty : $U_c = \pm 2.72\text{dB}$

2. ANTENNA REQUIREMENT

2.1. Standard Applicable

Section 15.203:

An intentional radiator shall be designed to ensure that no antenna other than that furnished by the responsible party shall be used with the device. The use of a permanently attached antenna or of an antenna that uses a unique coupling to the intentional radiator shall be considered sufficient to comply with the provisions of this Section. The manufacturer may design the unit so that a broken antenna can be replaced by the user, but the use of a standard antenna James or electrical connector is prohibited.

Section 15.247(b)/(c):

If transmitting antennas of directional gain greater than 6 dBi are used, the peak output power from the intentional radiator shall be reduced by the amount in dB that the directional gain of the antenna exceeds 6 dBi.

If the intentional radiator is used exclusively for fixed, point-to-point operations may employ transmitting antennas with directional gain greater than 6 dBi provided the maximum peak output power of the intentional radiator is reduced by 1 dB for every 3 dB that the directional gain of the antenna exceeds 6 dBi.

2.2. Antenna Connected Construction

The antenna connector is designed with permanent attachment and no consideration of replacement.

3. POWER LINE CONDUCTED MEASUREMENT

3.1. Test Equipment

See section 1.4.

3.2. Block Diagram of Test Setup

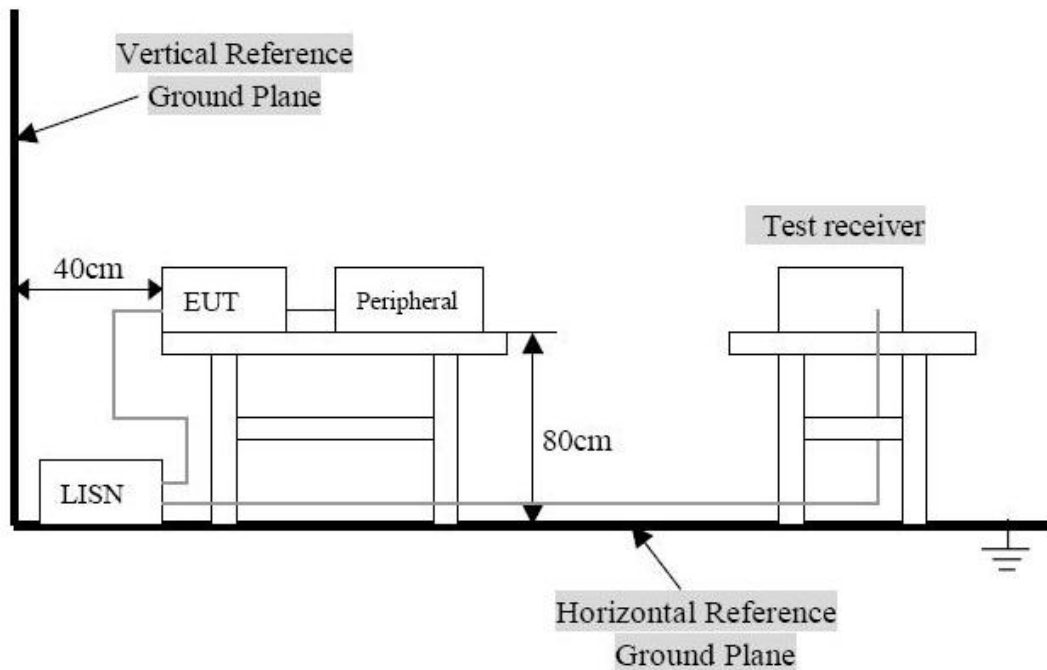

Remark: 1. The setup of EUT is according with per ANSI C63.4-2003 measurement procedure.
The specification used was with the FCC 15.207 limits.

3.3. Power Line Conducted Emission Measurement Limits(Class B)

Frequency MHz	Limits dB(μ V)	
	Quasi-peak Level	Average Level
0.15 ~ 0.50	66 ~ 56*	56 ~ 46*
0.50 ~ 5.00	56	46
5.00 ~ 30.00	60	50

Notes: 1. *Decreasing linearly with logarithm of frequency.
2. The lower limit shall apply at the transition frequencies.

3.4. Configuration of EUT on Measurement

The following equipments are installed on Power Line Conducted Emission Measurement to meet the commission requirement and operating regulations in a manner, which tends to maximize its emission characteristics in a normal application.

EUT	SEECODE WHEEL
Model Number	SHF20

3.5. Operating Condition of EUT

- 3.5.1. Setup the EUT and simulator as shown as Section 2.2.
- 3.5.2. Turn on the power of all equipment.
- 3.5.3. Let the EUT work in test mode (Normal) and measure it.

3.6. Test Procedure

The EUT system is connected to the power mains through a line impedance stabilization network (L.I.S.N.). This provides 50ohm-coupling impedance for the EUT system. Please refer the block diagram of the test setup and photographs. Both sides of AC line are checked to find out the maximum conducted emission. In order to find the maximum emission levels, the relative positions of equipment and all of the interface cables shall be changed according to ANSI C63.4-2003 on Conducted Emission Measurement.

The bandwidth of test receiver (R & S ESCS30) is set at 9KHz.

The frequency range from 150KHz to 30 MHz is investigated.

3.7. Power Line Conducted Emission Measurement Results

N/A

Because the product used in the vehicle, so the test can be omitted.

4. TEST OF HOPPING CHANNEL BANDWIDTH

4.1 Applicable Standard

Section 15.247(a)(1): Frequency hopping systems shall have hopping channel carrier frequencies separated by a minimum of 25 kHz or the 20 dB bandwidth of the hopping channel, whichever is greater.

4.2 EUT Setup

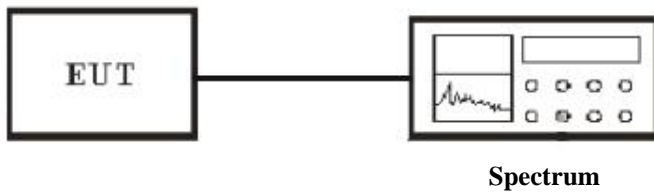

4.3 Test Equipment List and Details

See section 1.4.

4.4 Test Procedure

1. The transmitter output was connected to the spectrum analyzer through an attenuator.
2. Set RBW of spectrum analyzer to 10KHz and VBW to 30KHz.
3. Set Detector to Peak, Trace to Max Hold and Sweep Time is Auto.
4. The spectrum width with level higher than 20dB below the peak level.
5. Repeat above 1~3 points for the middle and highest channel of the EUT.

4.5 Test Result

Temperature () : 22~23	EUT: SEECODE WHEEL
Humidity (%RH) : 50~54	M/N: SHF20
Barometric Pressure (mbar) : 950~1000	Operation Condition: Tx/Rx Mode
Test data: Nov 29, 2007	Test engineer: James

Channel No.	Frequency (MHz)	20dB Bandwidth (kHz)	Min. Limit (kHz)
LOW	2402	940	>25
MID	2441	900	>25
HIG	2480	900	>25

Channel Low :

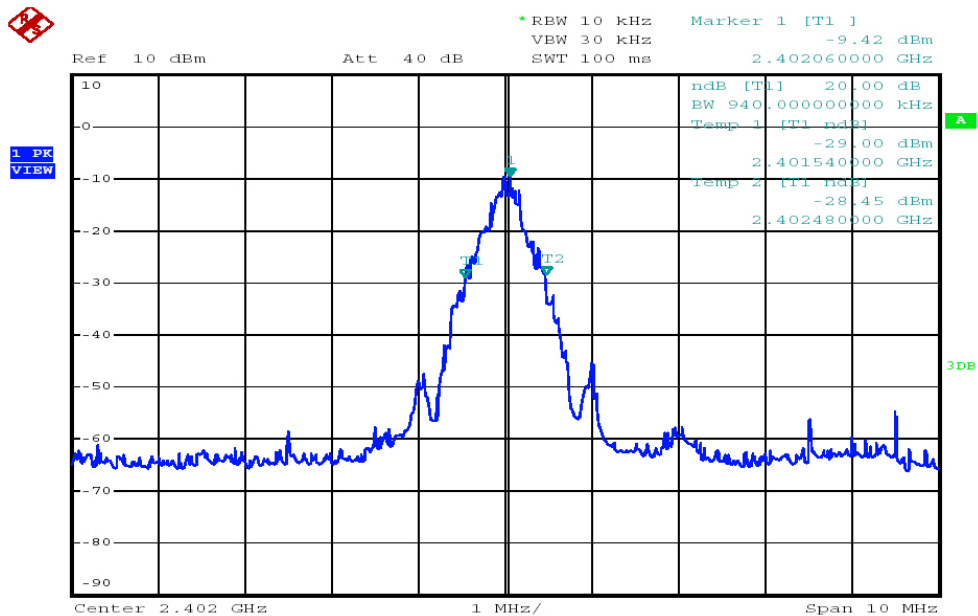

Channel MID :

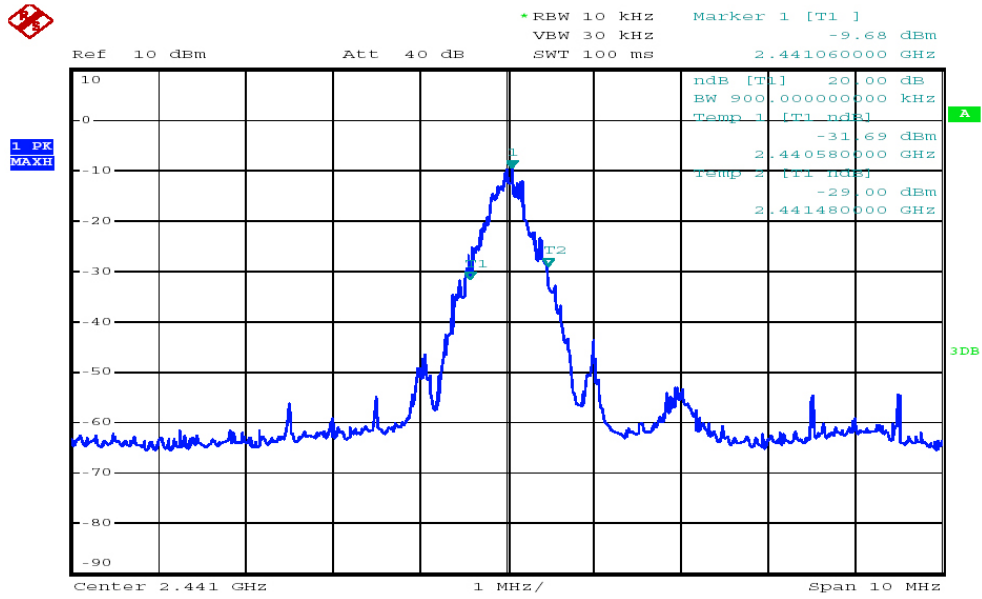

Channel HIG :

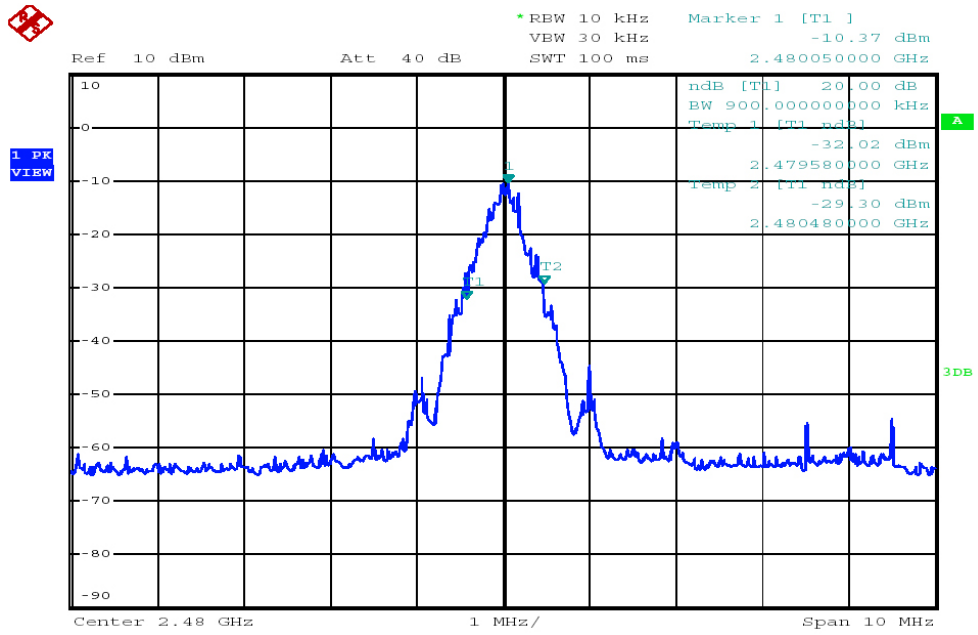

5. TEST OF HOPPING CHANNEL SEPARATION

5.1 Applicable Standard

Section 15.247(a)(1): Frequency hopping systems shall have hopping channel carrier frequencies separated by a minimum of 25 kHz or the 20 dB bandwidth of the hopping channel, whichever is greater.

5.2 EUT Setup

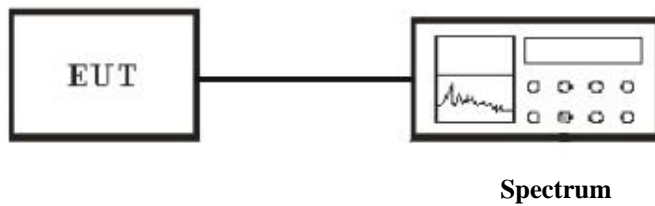

5.3 Test Equipment List and Details

See section 1.4.

5.4 Test Procedure

1. The transmitter output was connected to the spectrum analyzer through an attenuator.
2. Set RBW of spectrum analyzer to 100KHz and VBW to 300KHz.
3. Set Detector to Peak, Trace to Max Hold and Sweep Time is Auto.
4. The Hopping Channel Separation is defined as the separation between 2 neighboring hopping frequencies.
5. Repeat above 1~3 points for the middle and highest channel of the EUT.

5.5 Test Result

Temperature () : 22~23	EUT: SEECODE WHEEL
Humidity (%RH) : 50~54	M/N: SHF20
Barometric Pressure (mbar) : 950~1000	Operation Condition: Tx/Rx Mode
Test data: Nov 30, 2007	Test engineer: James

Channel No.	Frequency (MHz)	Channel Separation (kHz)
LOW	2402	1000
MID	2441	1000
HIG	2480	1000

Channel Low :

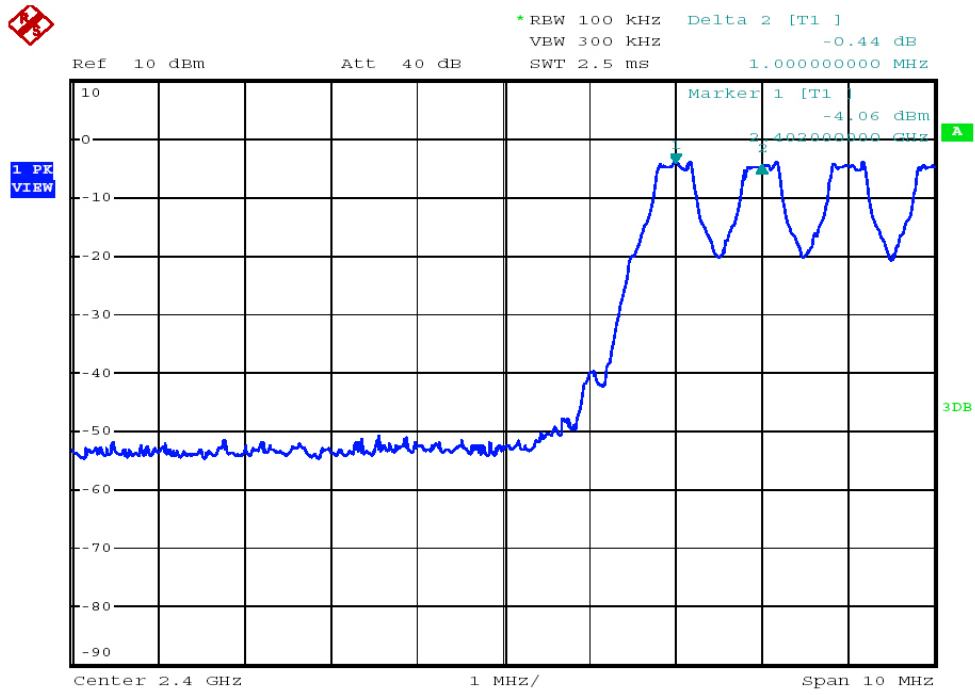

Channel MID :

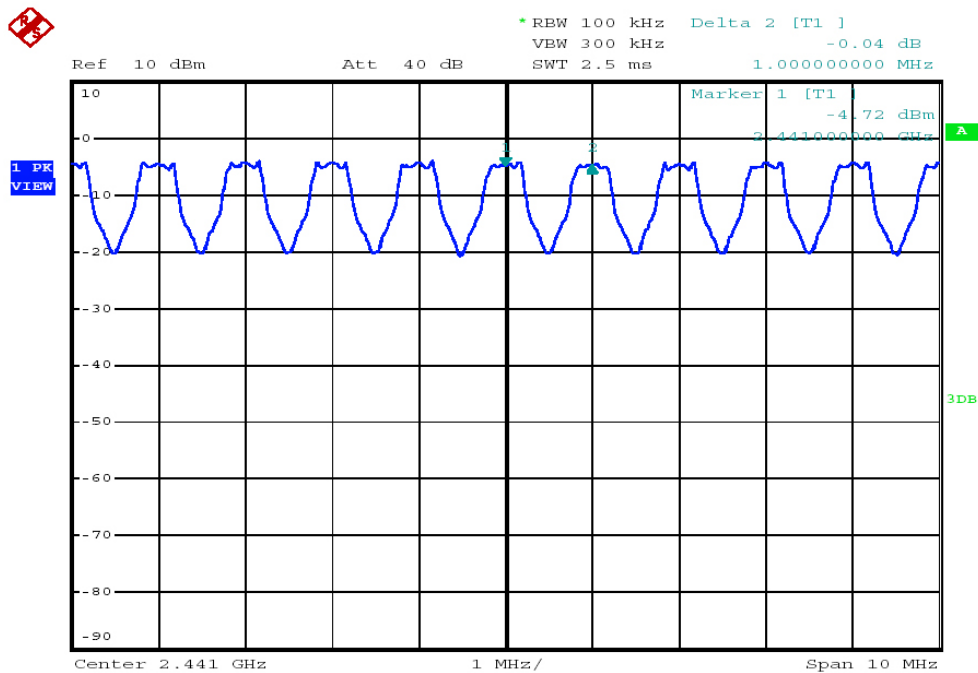

Channel HIG :

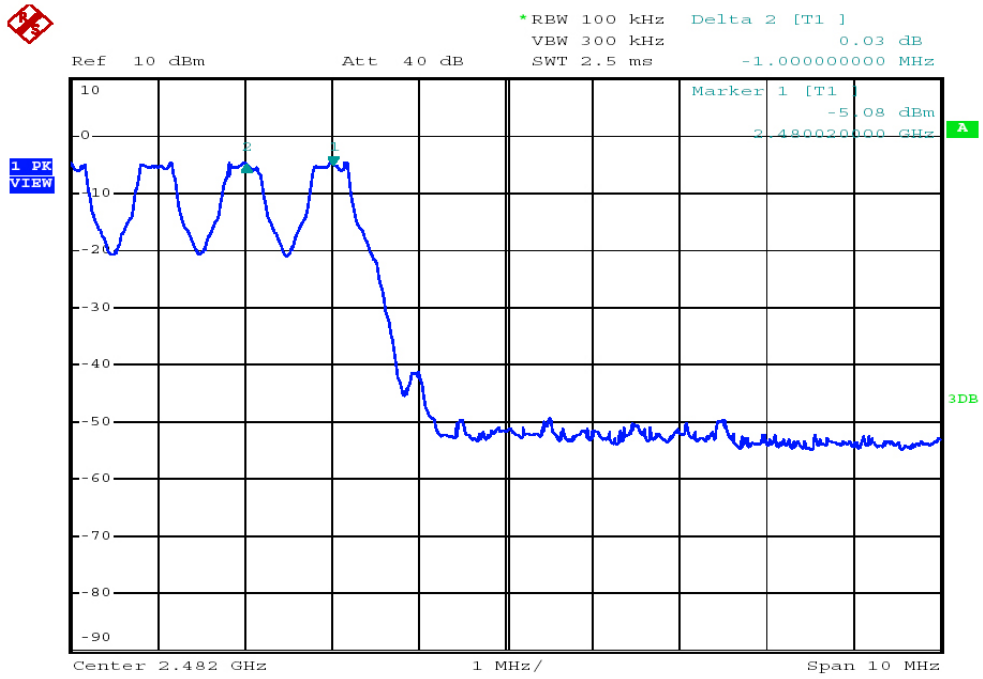

6. TEST OF NUMBER OF HOPPING FREQUENCY

6.1 Applicable Standard

Section 15.247(a)(1)(iii): For frequency hopping systems operating in the 2400-2483.5 MHz band employing at least 15 non-overlapping hopping channels. Frequency hopping system which use fewer than 75 hopping frequencies may employ intelligent hopping techniques to avoid interference to other transmissions. Frequency hopping system may avoid or suppress transmissions on a particular hopping frequency provided that a minimum of 15 non-overlapping channels are used.

6.2 EUT Setup

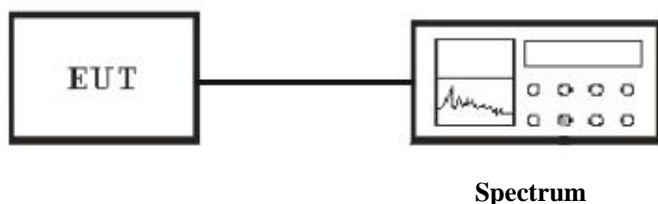

6.3 Test Equipment List and Details

See section 1.4.

6.4 Test Procedure

1. The transmitter output was connected to the spectrum analyzer through an attenuator.
2. Set RBW of spectrum analyzer to 100KHz and VBW to 300KHz.
3. Set Detector to Peak, Trace to Max Hold and Sweep Time is Auto.
4. Observe frequency hopping in 2400MHz~2483.5MHz, there are at least 79 non-overlapping channels.
5. Repeat above 1~3 points for the middle and highest channel of the EUT.

6.5 Test Result

Temperature () : 22~23	EUT: SEECODE WHEEL
Humidity (%RH) : 50~54	M/N: SHF20
Barometric Pressure (mbar) : 950~1000	Operation Condition: Tx/Rx Mode
Test data: Nov 29, 2007	Test engineer: James

Frequency (MHz)	Number of Hopping Channel (Channels)	Min. Limit (Channels)
2402~2480	79	>15

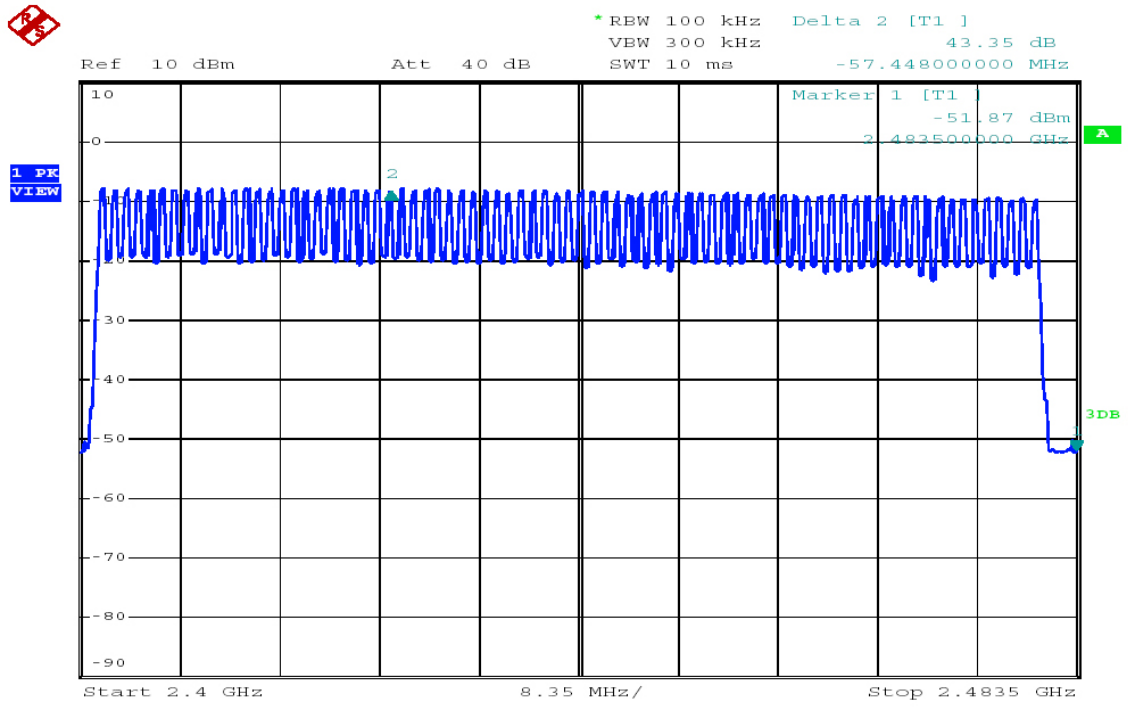

7. TEST OF DWELL TIME OF EACH FREQUENCY

7.1 Applicable Standard

Section 15.247(a)(1)(iii): For frequency hopping systems operating in the 2400-2483.5 MHz band
The average time of occupancy on any channel shall not be greater than 0.4 seconds within a period of 0.4seconds multiplied by the number of hopping channels employed.

7.2 EUT Setup

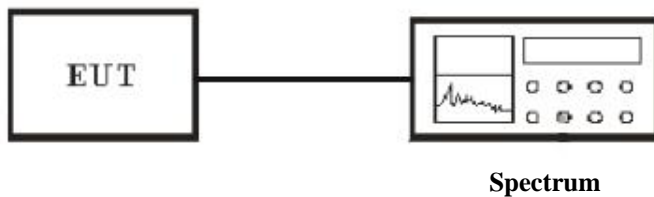

7.3 Test Equipment List and Details

See section 1.4.

7.4 Test Procedure

1. The transmitter output was connected to the spectrum analyzer through an attenuator.
2. Set RBW of spectrum analyzer to 1MHz and VBW to 1MHz.
3. Set Detector to Peak, Trace to Max Hold and Sweep Time is more than once pulse time.
4. Set the center frequency on any frequency would be measure and set the frequency span to zero span.
5. Measure the maximum time duration of one single pulse.

7.5 Test Result

Temperature () : 22~23	EUT: SEECODE WHEEL
Humidity (%RH) : 50~54	M/N: SHF20
Barometric Pressure (mbar) : 950~1000	Operation Condition: Tx/Rx Mode
Test data: Nov 30, 2007	Test engineer: James

Period = 0.4(seconds) x 79(channels) = 31.6 seconds

DH5 Mode

The Bluetooth system hops at a rate of 1600 times per second. This means there are 1600 timeslots in one second. The DH5 data rate operates on a five-slot transmission and one-slot receiving basis. Thus there are $1600/(5+1) = 266.7$ transmissions per second. In one period for each particular channel there are $3.38 \times 31.6 = 106.81$ times of transmissions.

- a) Channel Low : the dwell time is $2.900\text{ms} \times 106.81 = 309.330\text{ms}$
- b) Channel Middle : the dwell time is $2.900\text{ms} \times 106.81 = 309.330\text{ms}$
- c) Channel High : the dwell time is $2.880\text{ms} \times 106.81 = 307.200\text{ms}$

The maximum time of occupancy for a particular channel is 309.330 ms in any 31.6 second period, which is less than the 400 ms allowed by the rules; therefore, it meets the requirements of this section.

DH5 Mode : Channel Low

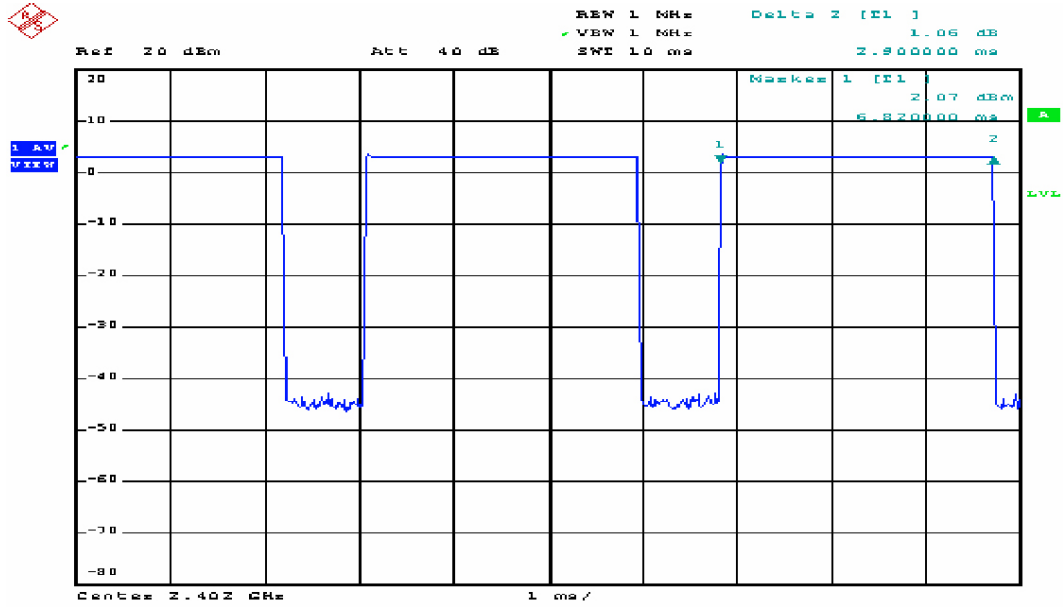

DH5 Mode : Channel MID

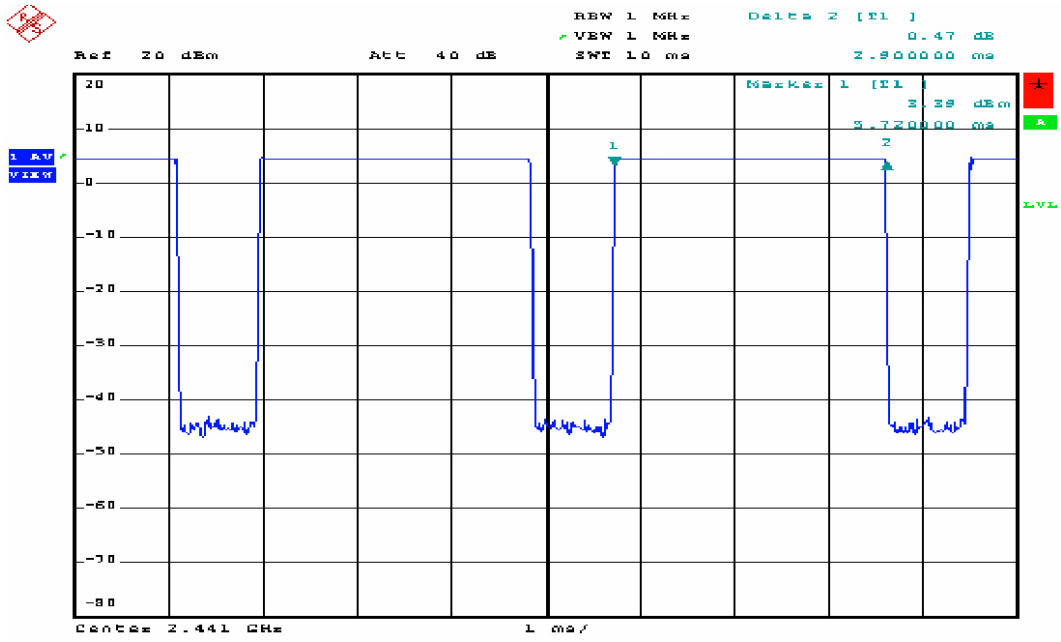

DH5 Mode : Channel HIG

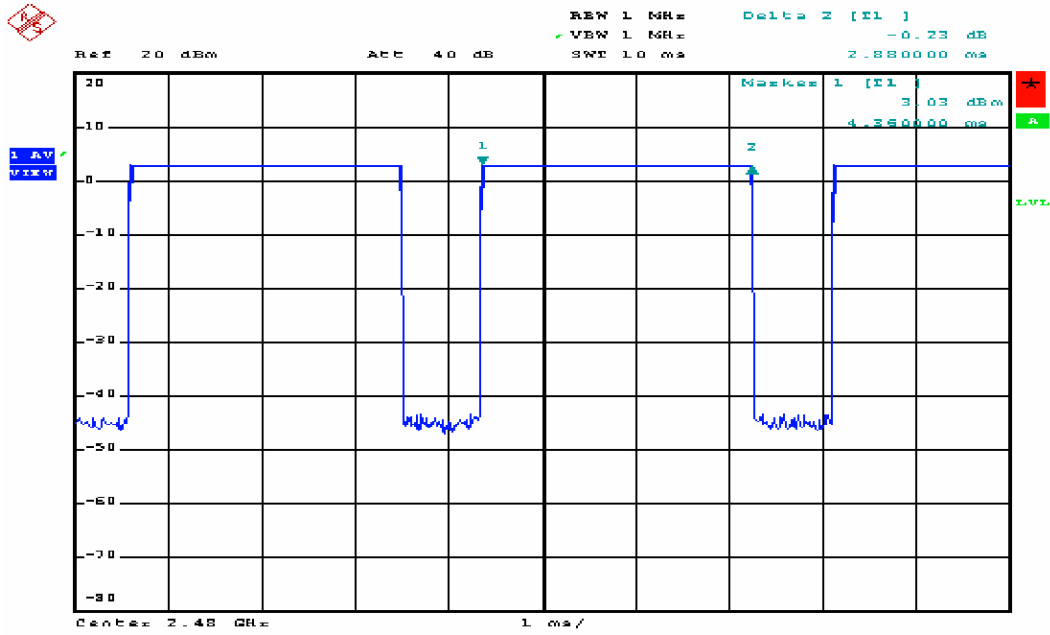

8. TEST OF MAXIMUM PEAK OUTPUT POWER

8.1 Applicable Standard

Section 15.247(b)(1): For frequency hopping systems operating in the 2400-2483.5 MHz band employing at least 75 non-overlapping hopping channels and The maximum peak output power shall not exceed 1 watt. For all other frequency hopping systems in this frequency band, The maximum peak output power shall not exceed 0.125 watt.

8.2 EUT Setup

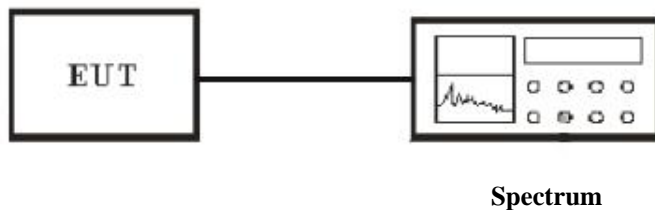

8.3 Test Equipment List and Details

See section 1.4.

8.4 Test Procedure

1. Check the calibration of the measuring instrument using either an internal calibrator or a known signal from an external generator.
2. Position the EUT as shown in figure 4 without connection to measurement instrument. Turn on the EUT and connect its antenna terminal to measurement instrument via a low loss cable. Then set it to any one measured frequency within its operating range and make sure the instrument is operated in its linear range.
3. Use the following spectrum analyzer settings:
 - Span = approximately 5 times the 20 dB bandwidth, centered on a hopping channel
 - RBW > the 20 dB bandwidth of the emission being measured
 - VBW \geq RBW
 - Sweep = auto
 - Detector function = peak
 - Trace = max hold
4. Allow the trace to stabilize. Use the marker-to-peak function to set the marker to the peak of the emission. The indicated level is the peak output power. Plot the result on the screen of spectrum analyzer.
5. Repeat above procedures until all frequencies measured were complete.

8.5 Test Result

For this device (79 hopping channels) the limit is 30 dBm (1 W).

Temperature () : 22~23	EUT: SEECODE WHEEL
Humidity (%RH) : 50~54	M/N: SHF20
Barometric Pressure (mbar) : 950~1000	Operation Condition: Tx/Rx Mode
Test data: Dec 03, 2007	Test engineer: James

Channel No.	Frequency (MHz)	Output Power (dBm)	Limits (dBm)
LOW	2402	-5.53	30
MID	2441	-5.64	30
HIG	2480	-6.14	30

Channel Low

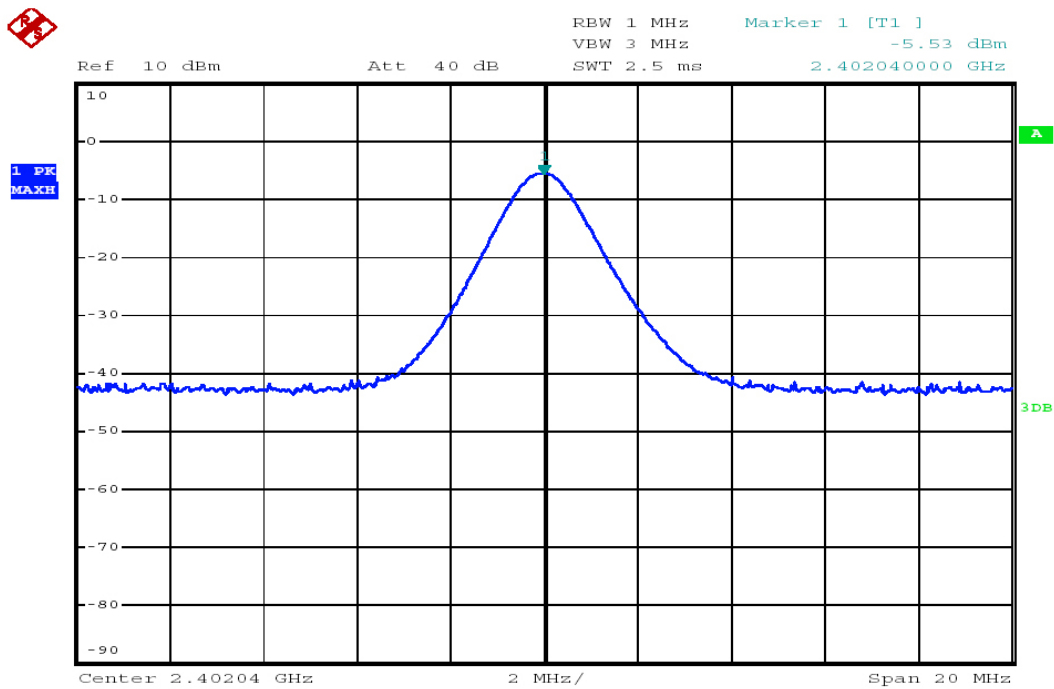

Channel MID

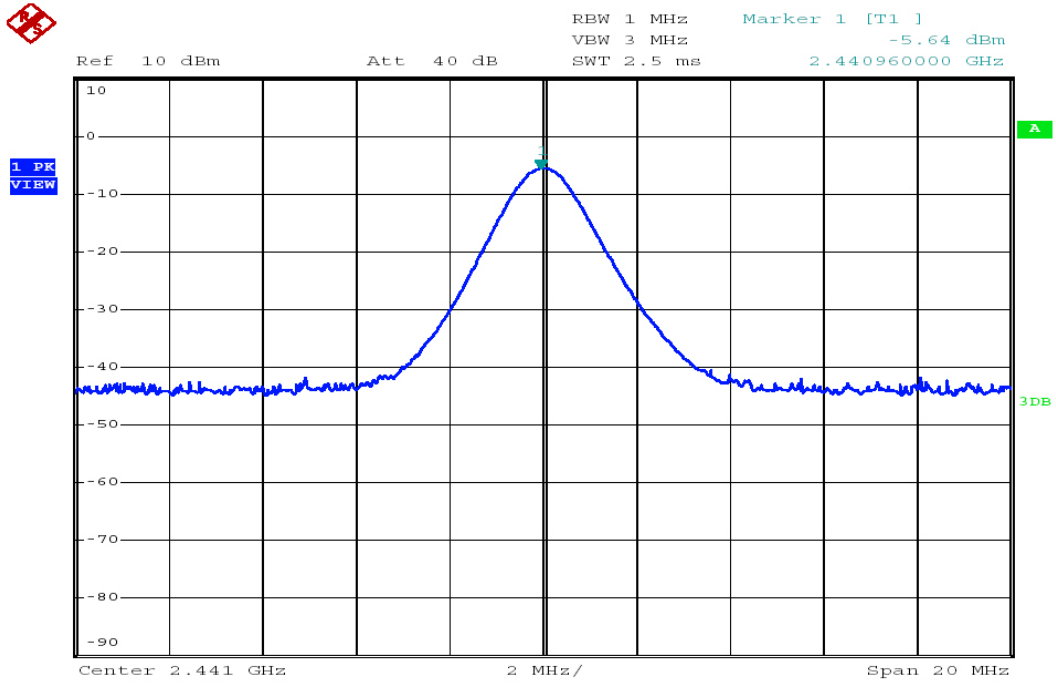

Channel H1G

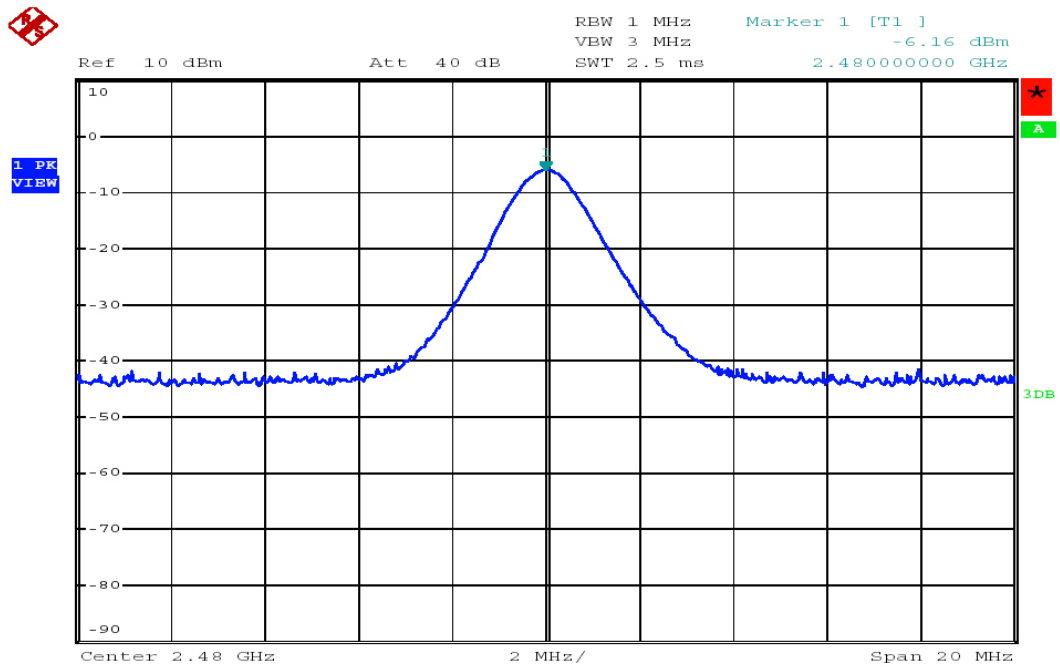

9. TEST OF BAND EDGES EMISSION

9.1 Applicable Standard

Section 15.247(d): In any 100 kHz bandwidth outside the frequency band in which the spread spectrum or digitally modulated intentional radiator is operating, the radio frequency power that is produced by the intentional radiator shall be at least 20 dB below that in the 100 kHz bandwidth within the band that contains the highest level of the desired power, based on either an RF conducted or a radiated measurement. In addition, radiated emissions that fall in the restricted bands, as defined in Section 15.205, must also comply with the radiated emission limits specified in Section 15.209.

9.2 EUT Setup

Radiated Measurement Setup

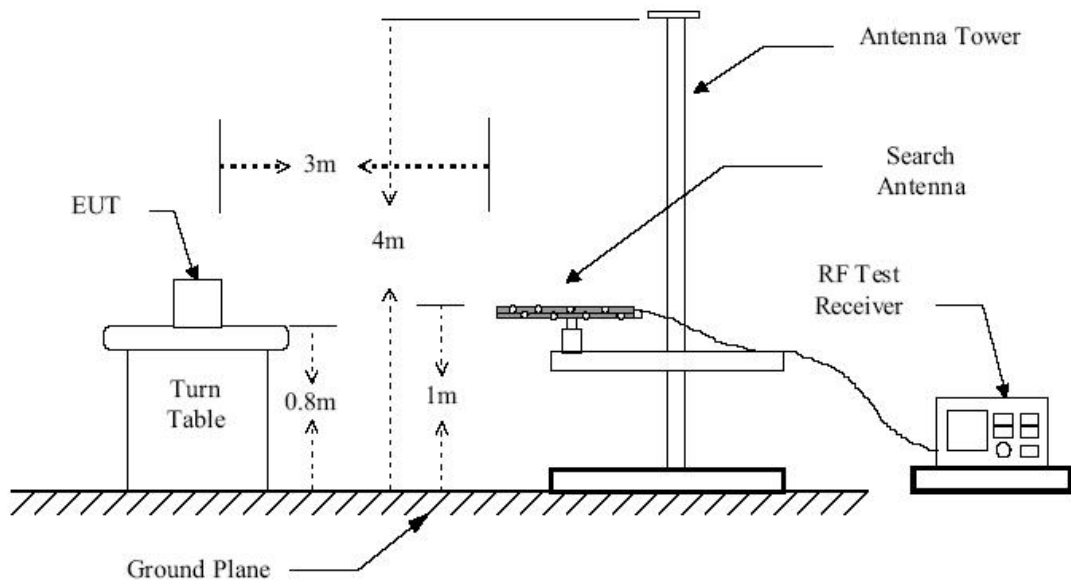

Conducted Measurement Setup

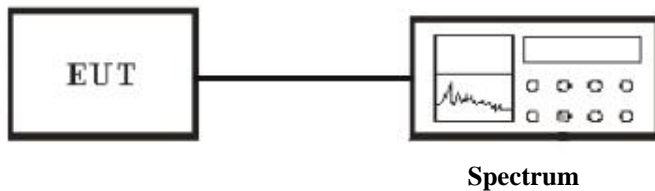

9.3 Test Equipment List and Details

See section 1.4.

9.4 Test Procedure

Conducted Measurement

1. The transmitter is set to the lowest channel.
2. The transmitter output was connected to the spectrum analyzer via a cable and cable loss is used as the offset of the spectrum analyzer.
3. Set both RBW and VBW of spectrum analyzer to 100KHz with convenient frequency span including 10MHz bandwidth from lower band edge. Then detector set to peak and max hold this trace.
4. The lowest band edges emission was measured and recorded.
5. The transmitter set to the highest channel and repeated 2~4.

Radiated Measurement

1. Configure the EUT according to ANSI C63.4.
2. The turntable was rotated by 360 degrees to determine the position of the highest radiation.
3. The height of the broadband receiving antenna was varied between one meter and four meters above ground to find the maximum emission field strength of both horizontal and vertical polarization.
4. For band edge emission, the antenna tower was scan (from 1 M to 4 M) and then the turn table was rotated (from 0 degree to 360 degrees) to find the maximum reading.
5. For band edge emission, use 10Hz VBW and 1MHz RBW for reading under AV and use 100KHz VBW and 300KHz RBW for reading under PK.

9.5 Test Result

Temperature () : 22~23	EUT: SEECODE WHEEL
Humidity (%RH) : 50~54	M/N: SHF20
Barometric Pressure (mbar) : 950~1000	Operation Condition: Tx/Rx Mode
Test data: Dec 03, 2007	Test engineer: James

Radiated Test Result

Frequency (MHz)	Antenna Polarization	Peak Value (dBμV/m)	AV Limits (dBμV/m)	Peak Limits (dBμV/m)
<2400	H	40.6	54	74
>2483.5	H	41.7	54	74

Conducted Test Result

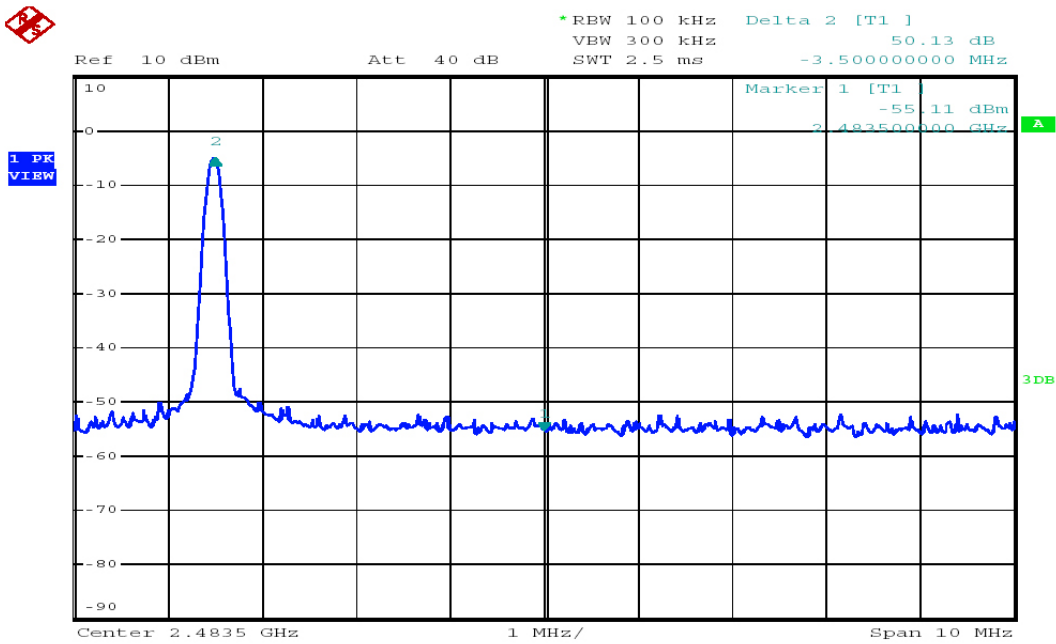
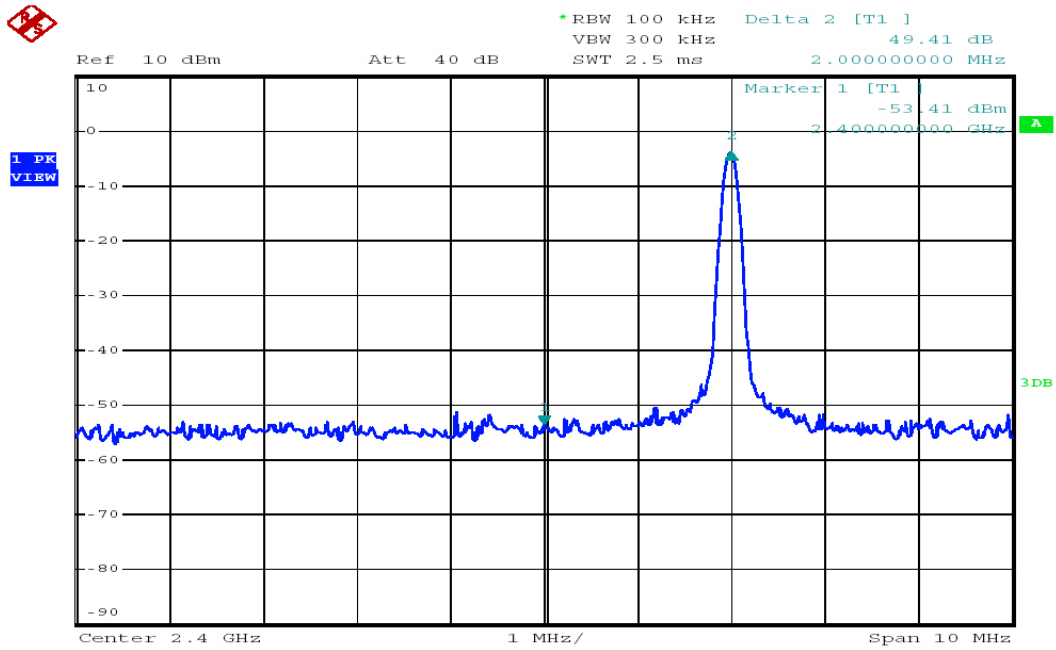

10. PEAK POWER SPECTRAL DENSITY MEASUREMENT

10.1 Standard Applicable

According to 15.247(d), for digitally modulated systems, the peak power spectral density conducted from the intentional radiator to the antenna shall not be greater than 8 dBm in any 3 kHz band during any time interval of continuous transmission.

10.2 Test Equipment List and Details

See section 1.4.

10.3 Measurement Procedure

1. Check the calibration of the measuring instrument using either an internal calibrator or a known signal from an external generator.
2. Position the EUT as shown in figure 4 without connection to measurement instrument. Turn on the EUT and connect its antenna terminal to measurement instrument via a low loss cable. Then set EUT to any one measured frequency within its operating range and make sure the instrument is operated in its linear range.
3. Use the following spectrum analyzer settings:
 - Span = 300 kHz, centered on highest level appearing on spectral display
 - RBW = 3 kHz
 - VBW \geq RBW
 - Sweep = 100 s
 - Detector function = peak
 - Trace = max hold
4. Allow the trace to stabilize. Use the marker-to-peak function to set the marker to the peak of the emission. Plot the result on the screen of spectrum analyzer.
5. Repeat above procedures until all measured frequencies were complete.

10.4 Test Result

N/A

The product is BT device, not apply for the test team.

11. TEST OF SPURIOUS RADIATED EMISSION

11.1 Applicable Standard

Section 15.247(d): In any 100 kHz bandwidth outside the frequency band in which the spread spectrum or digitally modulated intentional radiator is operating, the radio frequency power that is produced by the intentional radiator shall be at least 20 dB below that in the 100 kHz bandwidth within the band that contains the highest level of the desired power, based on either an RF conducted or a radiated measurement. In addition, radiated emissions that fall in the restricted bands, as defined in Section 15.205, must also comply with the radiated emission limits specified in Section 15.209.

11.2 EUT Setup

Radiated Measurement Setup

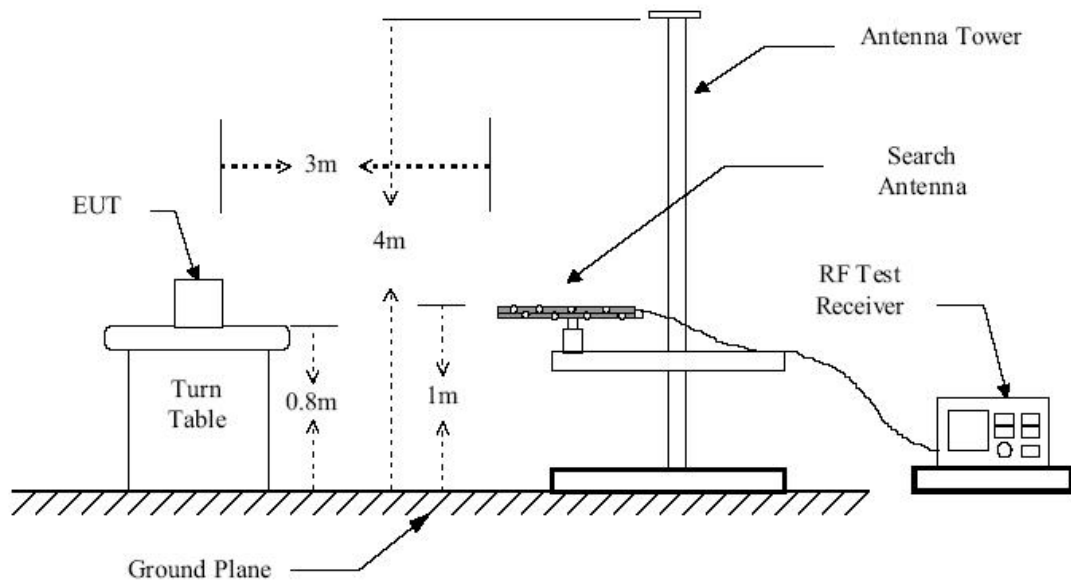

Figure 1 : Frequencies measured below 1 GHz configuration

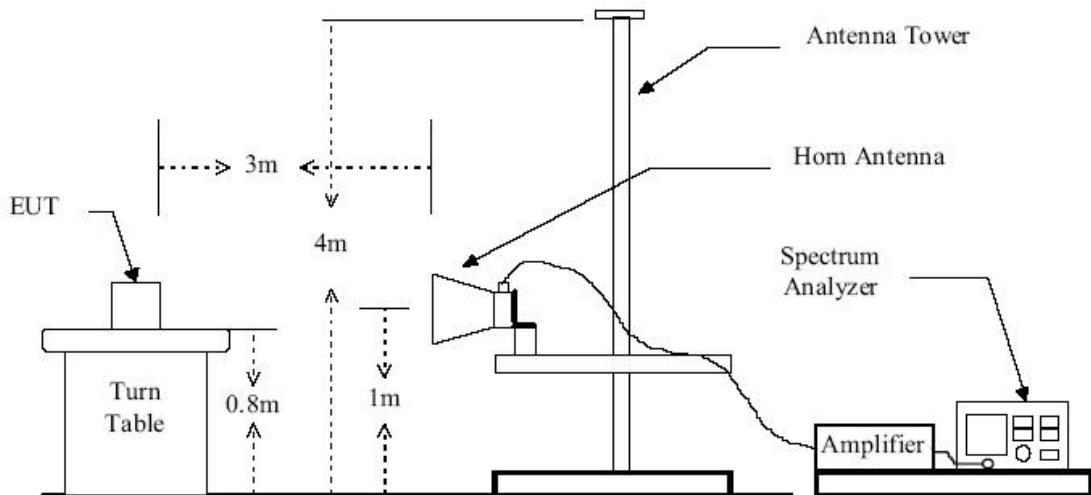
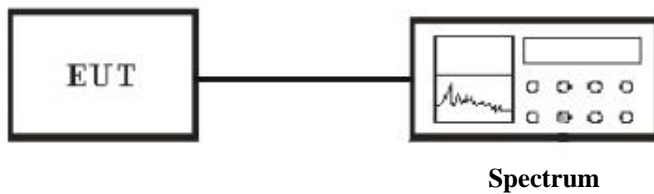

Figure 2 : Frequencies measured above 1 GHz configuration

Conducted Measurement Setup



11.3 Test Equipment List and Details

See section 1.4.

11.4 Test Procedure

Radiated Measurement

1. Configure the EUT according to ANSI C63.4.
2. The EUT was placed on the top of the turntable 0.8 meter above ground.
3. The phase center of the receiving antenna mounted on the top of a height-variable antenna tower was placed 3 meters far away from the turntable.
4. Power on the EUT and all the supporting units.
5. The turntable was rotated by 360 degrees to determine the position of the highest radiation.
6. The height of the broadband receiving antenna was varied between one meter and four meters above ground to find the maximum emission field strength of both horizontal and vertical polarization.
7. For each suspected emission, the antenna tower was scanned (from 1 M to 4 M) and then the turntable was rotated (from 0 degree to 360 degrees) to find the maximum reading.

8. Set the test-receiver system to Peak or CISPR quasi-peak Detect Function with specified bandwidth under Maximum Hold Mode.

Conducted Measurement

1. For emission above 1GHz, conducted measurement method is used.
2. The transmitter is set to the lowest channel.
3. The transmitter output was connected to the spectrum analyzer via a cable and cable loss is used as the offset of the spectrum analyzer.
4. Set RBW to 100KHz and VBW to 1 MHz, Then detector set to peak and max hold this trace.
5. The lowest band edges emission was measured and recorded.
6. The transmitter set to the highest channel and repeated 2~4.

11.5 Test Result

Temperature () : 22~23	EUT: SEECODE WHEEL
Humidity (%RH) : 50~54	M/N: SHF20
Barometric Pressure (mbar) : 950~1000	Operation Condition: Tx/Rx Mode
Test data: Dec 07, 2007	Test engineer: James

Spurious Emission (30~1000MHz)

Maximum Frequency (MHz)	Polarity and Level		Limit dBuV/m	Margin dBuv/m
	Polarity	Result dBuV/m		
30	V	27.9	40	12.1
82.3	V	26.8	40	13.2
195.8	V	26.7	43.5	16.8
30	H	24.6	40	15.4
200.1	H	36.5	43.5	7.0
669.4	H	35.3	46	10.7

Remark: No further spurious emission found between the lowest internal used/generated frequency and 30 MHz.

Harmonics

Channel HIG					
Maximum Frequency (MHz)	Polarity and Level		AV Limit dBuV/m	Peak Limit dBuV/m	Margin dBuv/m
	Polarity	Peak Result dBuV/m			
4960	H	44.6	54	74	9.4
4960	V	44.2	54	74	9.8
7440	H	26.9	54	74	27.1
7440	V	26.3	54	74	27.7
9920	--	--	--	--	--
9920	--	--	--	--	--
12400	--	--	--	--	--
14880	--	--	--	--	--
17360	--	--	--	--	--
19840	--	--	--	--	--
22320	--	--	--	--	--
24800	--	--	--	--	--

Remark: Datas of measurement within this frequency range shown “-” in the table above means the reading of emissions are attenuated more than 20dB below the permissible limits or the field strength is too small to be measured.

Channel MID					
Maximum Frequency (MHz)	Polarity and Level		AV Limit dBuV/m	Peak Limit dBuV/m	Margin dBuv/m
	Polarity	Peak Result dBuV/m			
4882	H	44.3	54	74	9.7
4882	V	42.8	54	74	11.2
7323	H	25.5	54	74	28.5
7323	V	26.1	54	74	27.9
9764	--	--	--	--	--
9764	--	--	--	--	--
12205	--	--	--	--	--
14646	--	--	--	--	--
17087	--	--	--	--	--
19528	--	--	--	--	--
21969	--	--	--	--	--
24410	--	--	--	--	--

Remark: Datas of measurement within this frequency range shown “-” in the table above means the reading of emissions are attenuated more than 20dB below the permissible limits or the field strength is too small to be measured.

Channel Low

Maximum Frequency (MHz)	Polarity and Level		AV Limit dBuV/m	Peak Limit dBuV/m	Margin dBuV/m
	Polarity	Peak Result dBuV/m			
4804	V	44	54	74	10
4804	H	43.1	54	74	10.9
7203	H	31	54	74	23
7203	V	29.6	54	74	24.4
9608	--	--	--	--	--
9608	--	--	--	--	--
12010	--	--	--	--	--
14412	--	--	--	--	--
16814	--	--	--	--	--
19216	--	--	--	--	--
21618	--	--	--	--	--
24020	--	--	--	--	--

Remark: Datas of measurement within this frequency range shown “-” in the table above means the reading of emissions are attenuated more than 20dB below the permissible limits or the field strength is too small to be measured.

CONDUCTED TEST RESULTS

Channel Low :

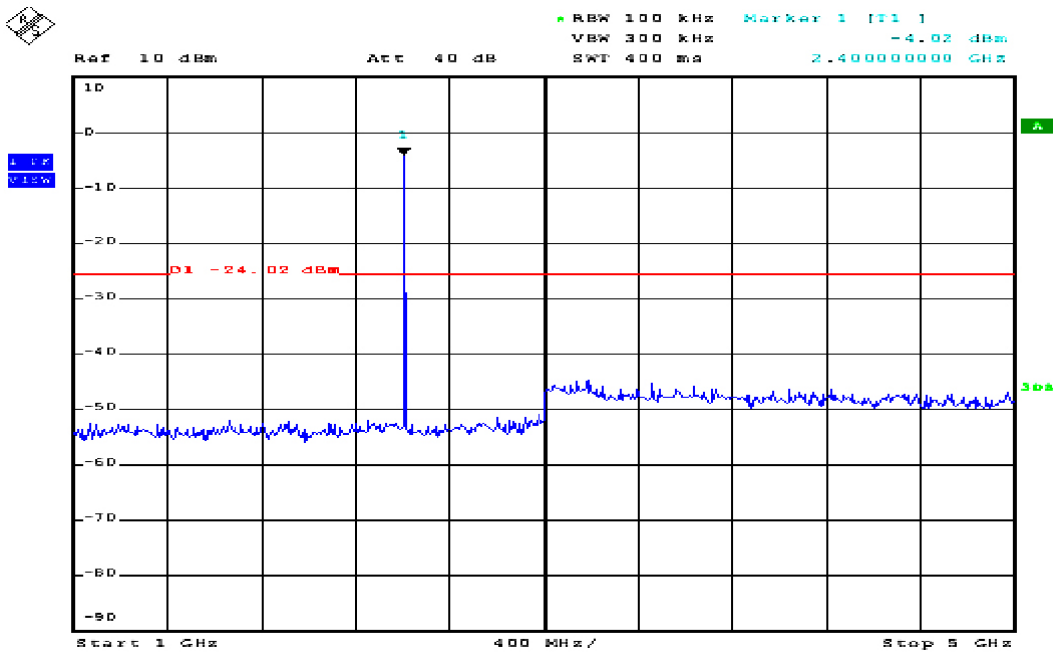
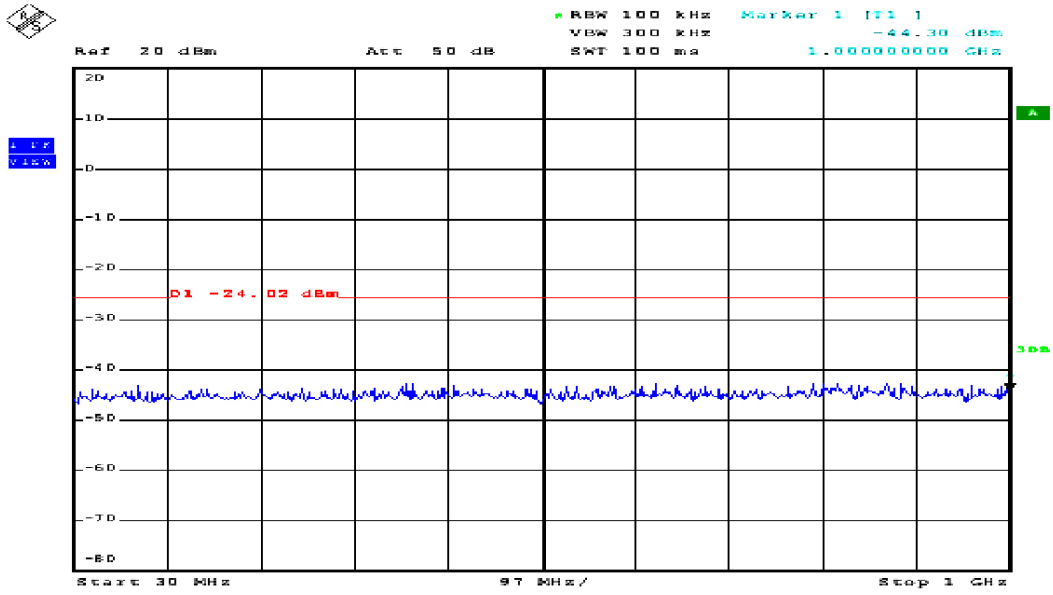

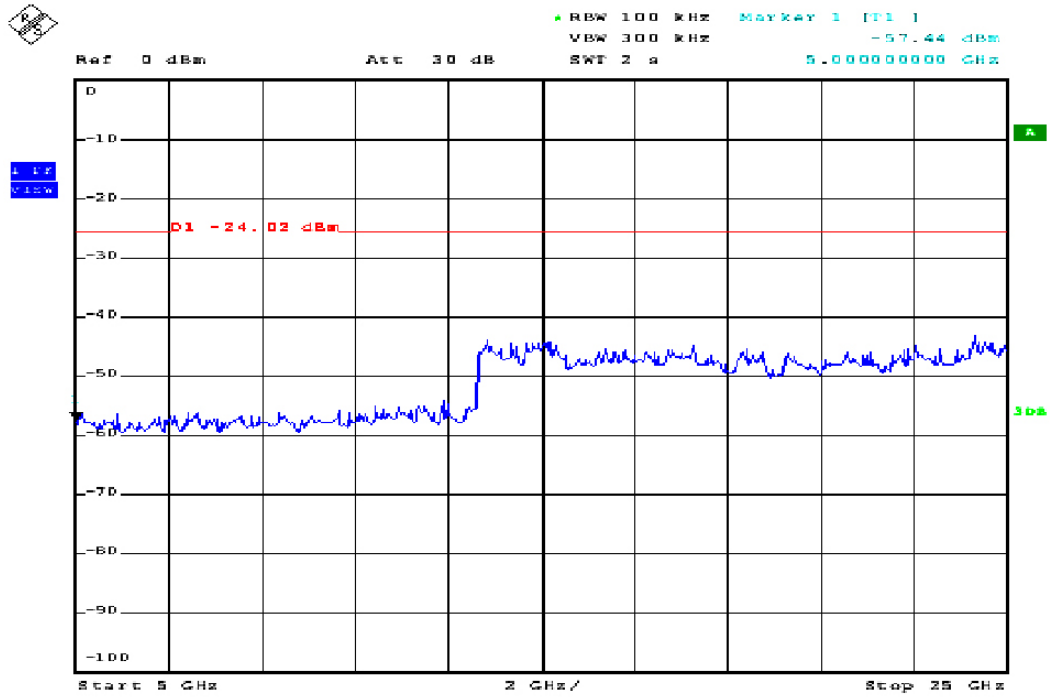

Channel MID :

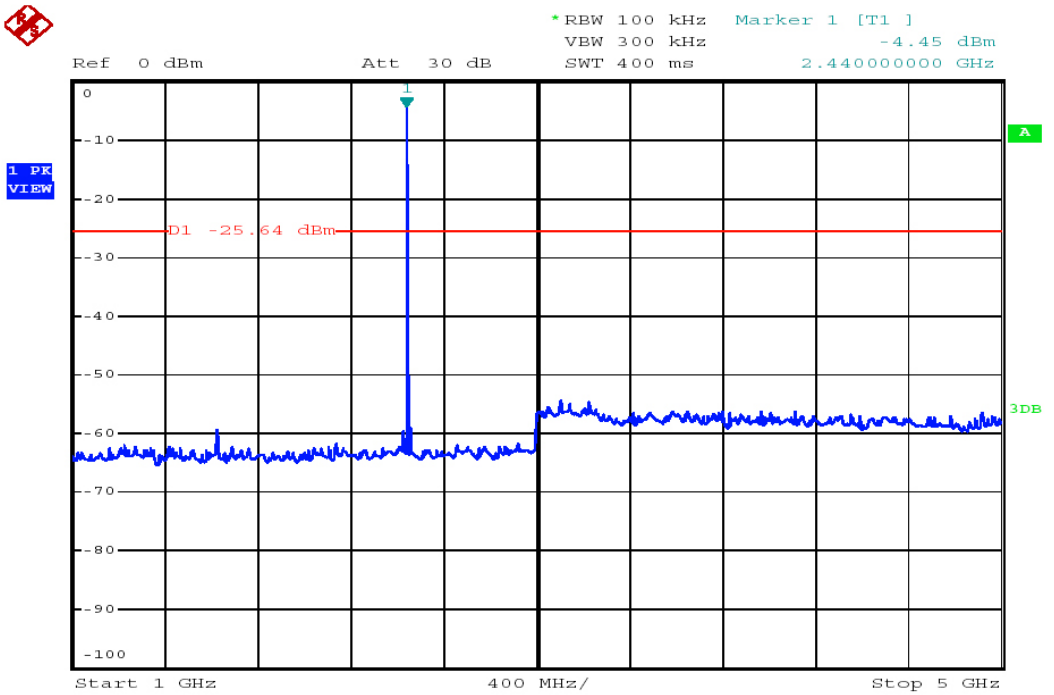
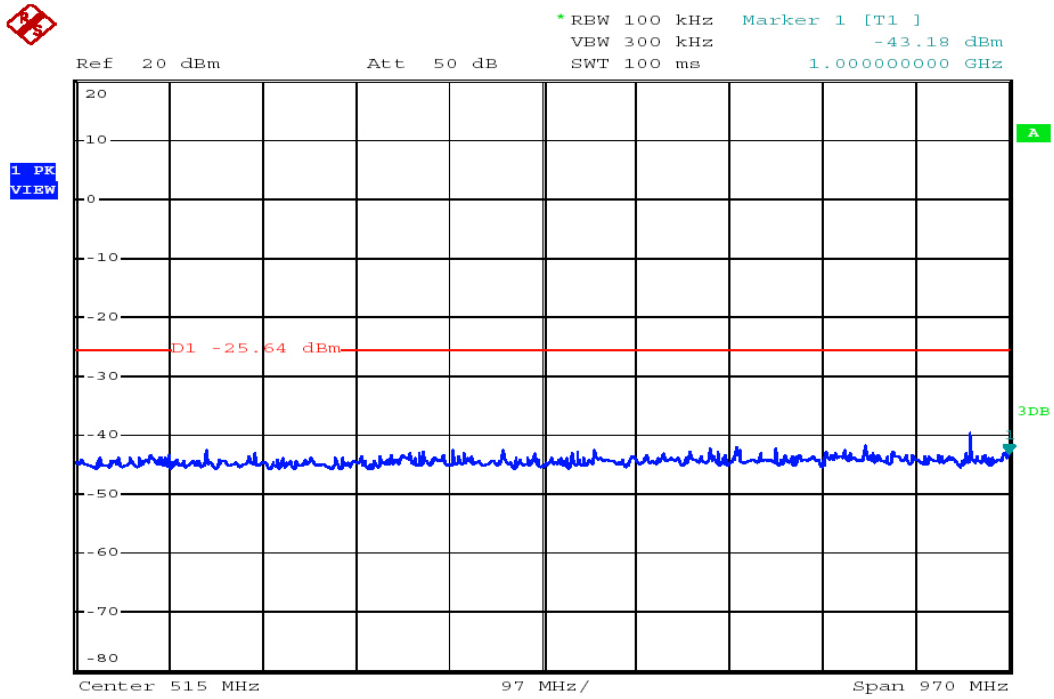

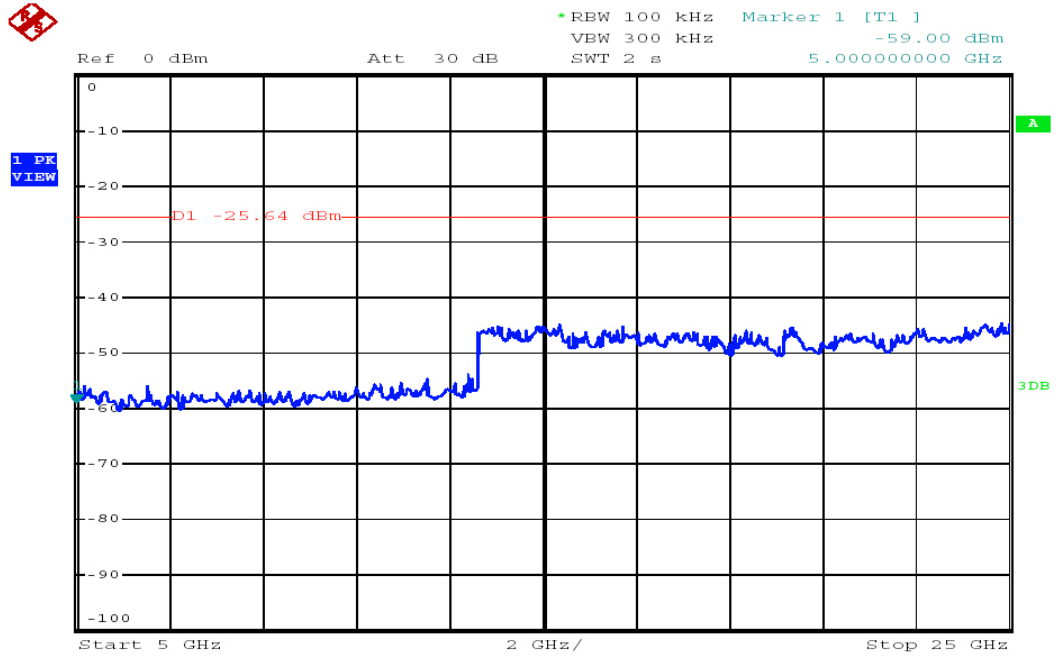

Channel HIG :

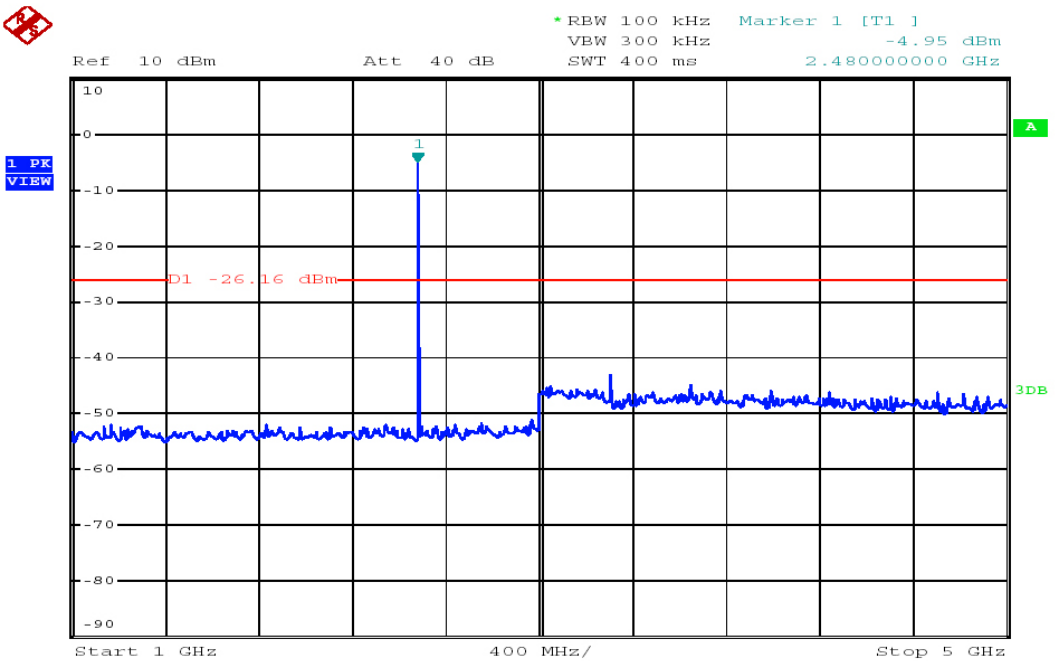
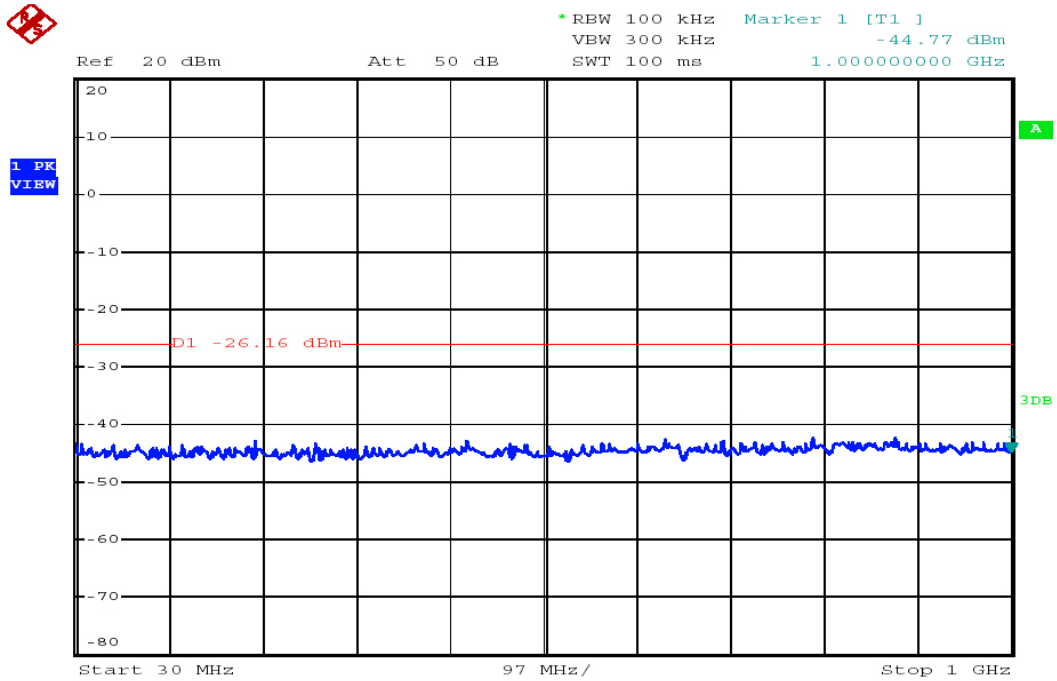

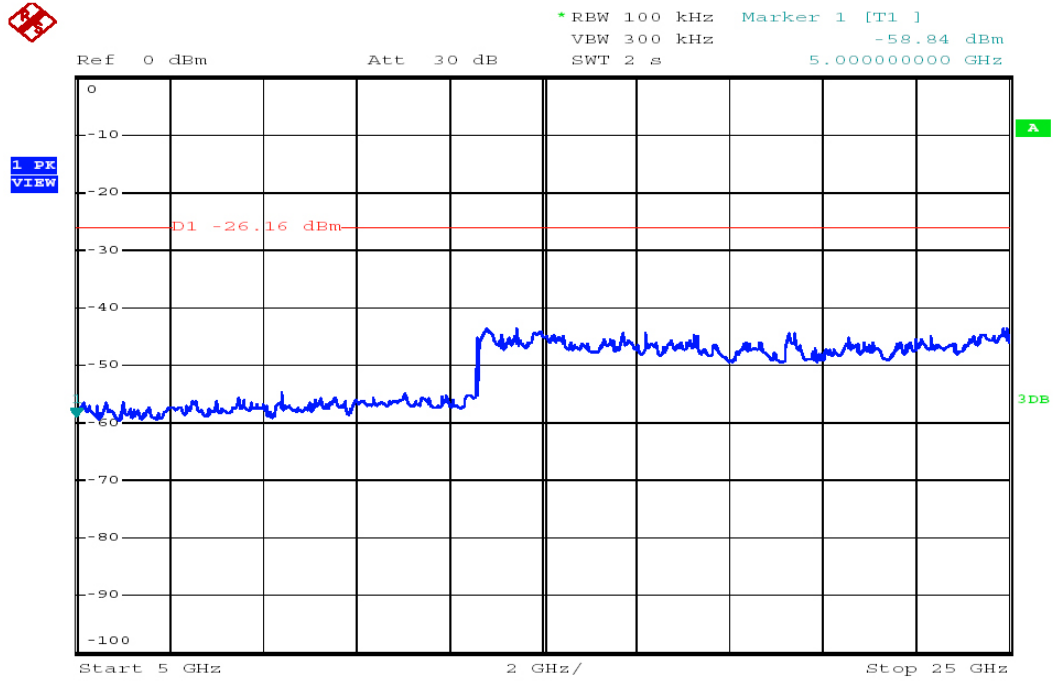

12.FCC ID LABEL

This device complies with Part 15 of the FCC Rules. Operation is subject to the following two conditions:(1)this device may not cause harmful interference, and (2) this device must accept any interference received, including interference that may cause undesired operation.

The Label must not be a stick-on paper. The Label on these products must be permanently affixed to the product and readily visible at the time of purchase and must last the expected lifetime of the equipment not be readily detachable.

Mark Location:



FCC ID Label Location

13.PHOTOGRAPH

13.1 Photo of Radiated Measurement

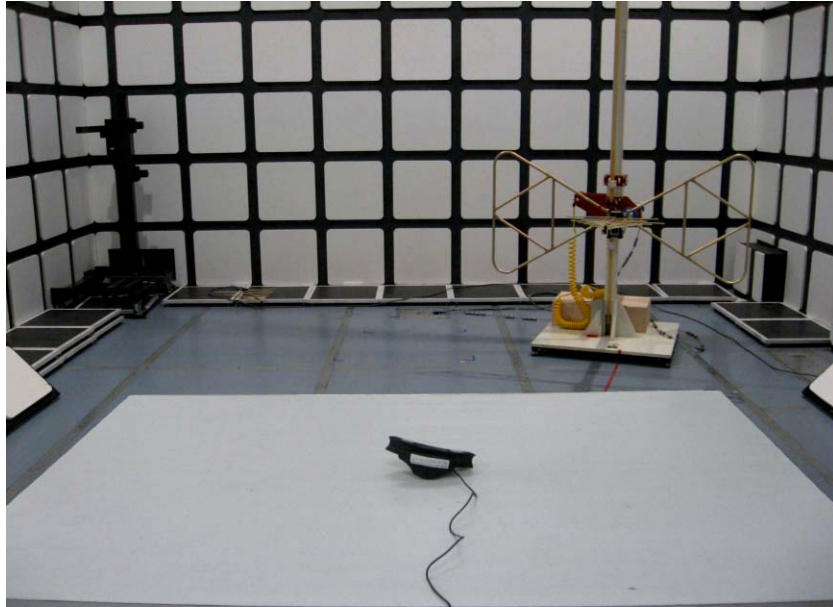

APPENDIX I

(Compliance Statements)

Subclause 15.247 (a) – Equal Hopping Frequency Use

Requirement: Each of the transmitter's hopping channels is used equally on average.

The EUT complies with the Bluetooth RF specifications. For details refer to the Bluetooth standard.

Subclause 15.247 (a) – Receiver Input Bandwidth

Requirement: The associated receiver(s) complies with the requirement that its input bandwidth matches the bandwidth of the transmitted signal.

The receiver bandwidth is equal to the receiver bandwidth in the 79 hopping channel mode, which is 1 MHz. The receiver bandwidth was verified during Bluetooth RF conformance testing.

Subclause 15.247 (a) – Receiver Hopping Capability

Requirement: The associated receiver has the ability to shift frequencies in synchronisation with the transmitted signals.

The EUT complies with the Bluetooth RF specifications. For details refer to the Bluetooth standard.

Subclause 15.247 (a) – Hopping Sequence

Requirement: The hopping sequence is generated and provided with an example.

The channel is represented by a pseudo-random hopping sequence hopping through the 79 RF channels. The hopping sequence is unique for the piconet and is determined by the Bluetooth device address of the master. The X input determines the phase in the 32-hop segment, whereas Y1 and Y2 selects between master-to-slave and slave-to-master transmission. The inputs A to D determine the ordering within the segment, the inputs E and F determine the mapping onto the hop frequencies.

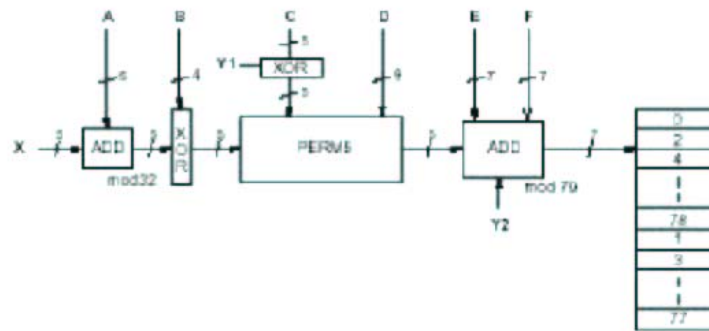

Example data:

Hop sequence {k} for CONNECTION STATE:
 CLK start: 0x0000010
 ULAP: 0x00000000

#ticks:	00 02	04 06	08 0a	0c 0e	10 12	14 16	18 1a	1c 1e
0x0000010:	08 66	10 70	12 19	14 23	16 01	18 05	20 33	22 37
0x0000030:	24 03	26 07	28 35	30 39	32 72	34 76	36 25	38 29
0x0000050:	40 74	42 78	44 27	46 31	48 09	50 13	52 41	54 45
0x0000070:	56 11	58 15	60 43	62 47	32 17	36 19	34 49	38 51
0x0000090:	40 21	44 23	42 53	46 55	48 33	52 35	50 65	54 67
0x00000b0:	56 37	60 39	58 69	62 71	64 25	68 27	66 57	70 59
0x00000d0:	72 29	76 31	74 61	78 63	01 41	05 43	03 73	07 75
0x00000f0:	09 45	13 47	11 77	15 00	64 49	66 53	68 02	70 06
0x0000110:	01 51	03 55	05 04	07 08	72 57	74 61	76 10	78 14
0x0000130:	09 59	11 63	13 12	15 16	17 65	19 69	21 18	23 22
0x0000150:	33 67	35 71	37 20	39 24	25 73	27 77	29 26	31 30
0x0000170:	41 75	43 00	45 28	47 32	17 02	21 04	19 34	23 36
0x0000190:	33 06	37 08	35 38	39 40	25 10	29 12	27 42	31 44
0x00001b0:	41 14	45 16	43 46	47 48	49 18	53 20	51 50	55 52
0x00001d0:	65 22	69 24	67 54	71 56	57 26	61 28	59 58	63 60
0x00001f0:	73 30	77 32	75 62	00 64	49 34	51 42	57 66	59 74
0x0000210:	53 36	55 44	61 68	63 76	65 50	67 58	73 03	75 11
0x0000230:	69 52	71 60	77 05	00 13	02 38	04 46	10 70	12 78
0x0000250:	06 40	08 48	14 72	16 01	18 54	20 62	26 07	28 15
0x0000270:	22 56	24 64	30 09	32 17	02 66	06 74	10 19	14 27
0x0000290:	04 70	08 78	12 23	16 31	18 03	22 11	26 35	30 43
0x00002b0:	20 07	24 15	28 39	32 47	34 68	38 76	42 21	46 29
0x00002d0:	36 72	40 01	44 25	48 33	50 05	54 13	58 37	62 45
0x00002f0:	52 09	56 17	60 41	64 49	34 19	36 35	50 51	52 67
0x0000310:	38 21	40 37	54 53	56 69	42 27	44 43	58 59	60 75
0x0000330:	46 29	48 45	62 61	64 77	66 23	68 39	03 55	05 71
0x0000350:	70 25	72 41	07 57	09 73	74 31	76 47	11 63	13 00
0x0000370:	78 33	01 49	15 65	17 02	66 51	70 67	03 04	07 20
0x0000390:	68 55	72 71	05 08	09 24	74 59	78 75	11 12	15 28
0x00003b0:	76 63	01 00	13 16	17 32	19 53	23 69	35 06	39 22
0x00003d0:	21 57	25 73	37 10	41 26	27 61	31 77	43 14	47 30
0x00003f0:	29 65	33 02	45 18	49 34	19 04	21 08	23 20	25 24

APPENDIX II (Photos of EUT)

Outside View



Interior View



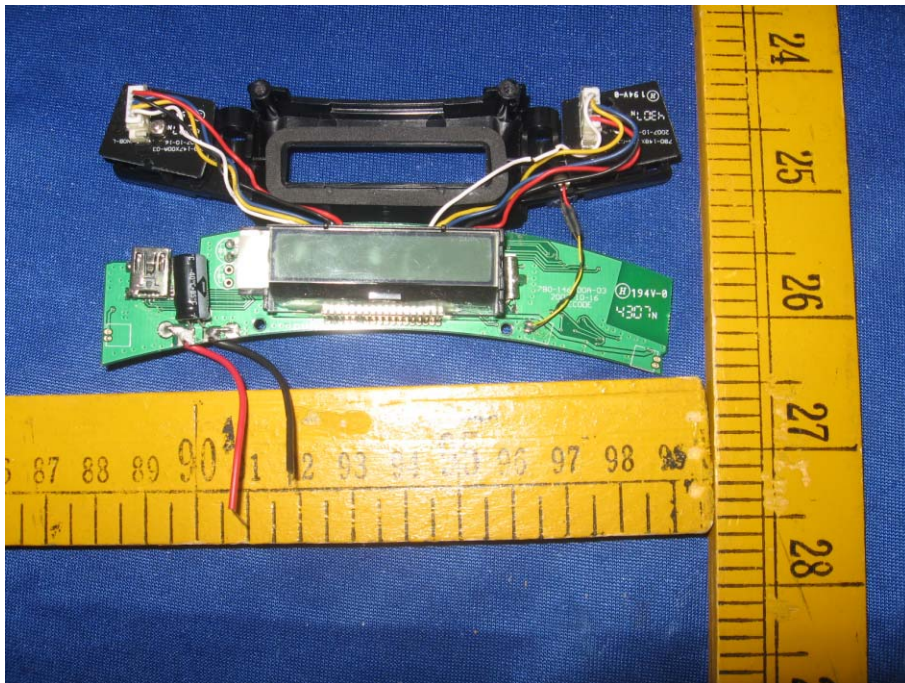
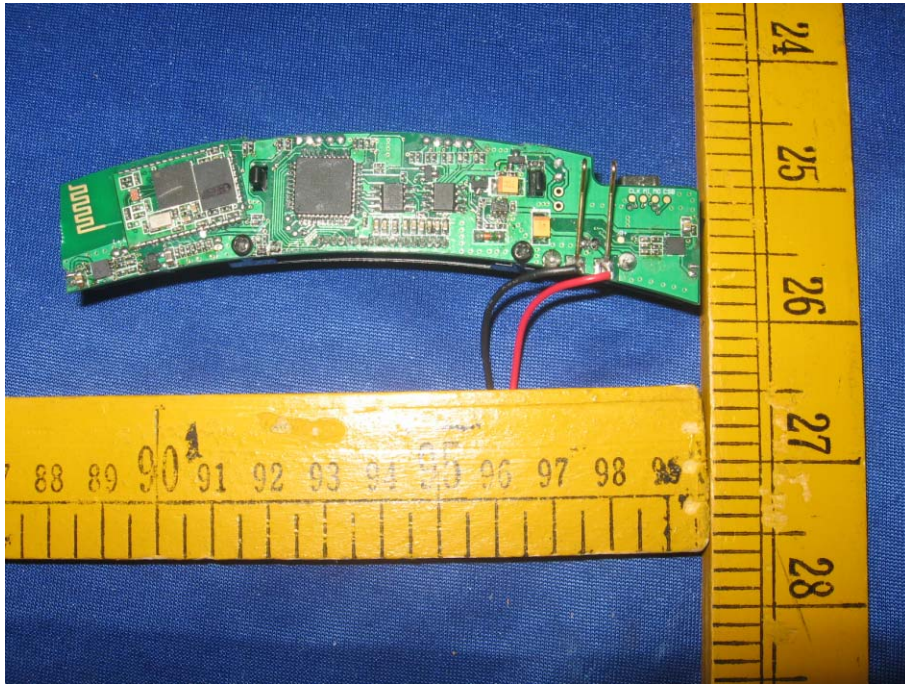

THE END