

control; such agreements and instruments include articles of incorporation and bylaws, shareholder agreements, voting or other trust agreements, franchise agreements, and any other relevant agreements (including letters of intent), oral or written; and

(3) List and summarize any investor protection agreements, including rights of first refusal, supermajority clauses, options, veto rights, and rights to hire and fire employees and to appoint members to boards of directors or management committees.

(c) *Records maintenance.* All winning bidders qualifying as small businesses, shall maintain at their principal place of business an updated file of ownership, revenue and asset information, including any document necessary to establish eligibility as a small business and/or consortium of small businesses under §90.912. Licensees (and their successors in interest) shall maintain such files for the term of the license.

(d) *Audits.* (1) Applicants and licensees claiming eligibility as a small business and/or consortium of small businesses under §§90.910 and 90.911 shall be subject to audits by the Commission, using in-house and contract resources. Selection for audit may be random, on information, or on the basis of other factors.

(2) Consent to such audits is part of the certification included in the short-form application (FCC Form 175). Such consent shall include consent to the audit of the applicant's or licensee's books, documents and other material (including accounting procedures and practices) regardless of form or type, sufficient to confirm that such applicant's or licensee's representations are, and remain, accurate. Such consent shall include inspection at all reasonable times of the facilities, or parts thereof, engaged in providing and transacting business, or keeping records regarding licensed 800 MHz SMR service and shall also include consent to the interview of principals, employees, customers and suppliers of the applicant or licensee.

(3) *Definitions.* The terms affiliate, attributable interests, consortium of small businesses, gross revenues, small business used in this section are defined in §90.912.

## PART 94—[Reserved]

## PART 95—PERSONAL RADIO SERVICES

### Subpart A—General Mobile Radio Service (GMRS)

#### GENERAL PROVISIONS

##### Sec.

- 95.1 The General Mobile Radio Service (GMRS).
- 95.3 License required.
- 95.5 License eligibility.
- 95.7 Channel sharing.

#### CONSIDERATIONS WHEN PLANNING A GMRS SYSTEM

- 95.21 GMRS system description.
- 95.23 Mobile station description.
- 95.25 Land station description.
- 95.27 Paging receiver description.
- 95.29 Channels available.
- 95.31 Overlap of GMRS systems.
- 95.33 Cooperative use of radio stations in the GMRS.
- 95.35 Multiple licensing of radio transmitting equipment in the GMRS.
- 95.37 Considerations near the Canadian border.
- 95.39 Considerations near FCC monitoring stations.
- 95.41 Considerations in the National Radio Quiet Zone.
- 95.43 Environmental considerations.
- 95.45 Considerations on Department of Defense land.
- 95.47 Considerations in large urban areas.
- 95.49 Considerations near large urban areas.
- 95.51 Antenna height.
- 95.53 Mobile station communication points.
- 95.55 Base station communication points.
- 95.57 Mobile relay station communication points.
- 95.59 Control station communication points.
- 95.61 Fixed station communication points.

#### APPLYING FOR A GMRS SYSTEM LICENSE

- 95.71 Applying for a new or modified license.
- 95.72 Applying for an STA or waiver of the rules.
- 95.73 System licensing.
- 95.75 Basic information.
- 95.77 Additional information for GMRS systems with land stations at four or more locations.
- 95.79 Additional information for stations in the National Radio Quiet Zone.
- 95.83 Additional information for stations with antennas higher than normally allowed.
- 95.85 Additional information for stations near United States borders.

- 95.87 Who may sign applications.  
95.89 Renewing a license.

#### MANAGING A GMRS SYSTEM

- 95.101 What the license authorizes.  
95.103 Licensee duties.  
95.105 License term.  
95.107 Keeping the license.  
95.109 License not transferable.  
95.111 Transfer of control of a corporation.  
95.113 System records.  
95.115 Station inspection.  
95.117 Where to contact the FCC.  
95.119 Station identification.  
95.121 Transmitting channel.  
95.123 Sharing a station or sharing equipment.  
95.125 Station control point.  
95.127 Controlling a station from a remote point.  
95.129 Station equipment.  
95.131 Servicing station transmitters.  
95.133 Modification to station transmitters.  
95.135 Maximum authorized transmitting power.  
95.137 Moving a small base station or a small control station.  
95.139 Adding a small base station or a small control station.  
95.141 Interconnection prohibited.  
95.143 Managing a GMRS system in an emergency.

#### OPERATING A GMRS STATION

- 95.171 Station operator at control point.  
95.173 Station operator duties.  
95.175 Cooperation in sharing channels.  
95.177 Responsibility for station operator's communications.  
95.179 Individuals who may be station operators.  
95.181 Permissible communications.

#### APPENDIX A TO SUBPART A—MAKING A CONTROL STATION POWER TEST

#### APPENDIX B TO SUBPART A—WHERE THE LARGE URBAN AREAS ARE LOCATED

### Subpart B—Family Radio Service (FRS)

#### GENERAL PROVISIONS

- 95.191 (FRS Rule 1) Eligibility and responsibility.  
95.192 (FRS Rule 2) Authorized locations.  
95.193 (FRS Rule 3) Types of communications.  
95.194 (FRS Rule 4) FRS units.

### Subpart C—Radio Control (R/C) Radio Service

#### GENERAL PROVISIONS

- 95.201 (R/C Rule 1) What is the Radio Control (R/C) Radio Service?  
95.202 (R/C Rule 2) How do I use these rules?

- 95.203 (R/C Rule 3) Am I eligible to operate an R/C station?  
95.204 (R/C Rule 4) Do I need a license?  
95.205 (R/C Rule 5) Where may I operate my R/C station?  
95.206 (R/C Rule 6) Are there any special restrictions on the location of my R/C station?

#### HOW TO OPERATE AN R/C STATION

- 95.207 (R/C Rule 7) On what channels may I operate?  
95.208 (R/C Rule 8) How high may I put my antenna?  
95.209 (R/C Rule 9) What equipment may I use at my R/C station?  
95.210 (R/C Rule 10) How much power may I use?  
95.211 (R/C Rule 11) What communications may be transmitted?  
95.212 (R/C Rule 12) What communications are prohibited?  
95.213 (R/C Rule 13) May I be paid to use my R/C station?  
95.214 (R/C Rule 14) Who is responsible for R/C communications I make?  
95.215 (R/C Rule 15) Do I have to limit the length of my communications?  
95.216 (R/C Rule 16) Do I identify my R/C communications?  
95.217 (R/C Rule 17) May I operate my R/C station transmitter by remote control?

#### OTHER THINGS YOU NEED TO KNOW

- 95.218 (R/C Rule 18) What are the penalties for violating these rules?  
95.219 (R/C Rule 19) How do I answer correspondence from the FCC?  
95.220 (R/C Rule 20) What must I do if the FCC tells me that my R/C station is causing interference?  
95.221 (R/C Rule 21) How do I have my R/C transmitter serviced?  
95.222 (R/C Rule 22) May I make any changes to my R/C station transmitter?  
95.223 (R/C Rule 23) Do I have to make my R/C station available for inspection?  
95.224 (R/C Rule 24) What are my station records?  
95.225 (R/C Rule 25) How do I contact the FCC?

### Subpart D—Citizens Band (CB) Radio Service

#### GENERAL PROVISIONS

- 95.401 (CB Rule 1) What are the Citizens Band Radio Services?  
95.402 (CB Rule 2) How do I use these rules?  
95.403 (CB Rule 3) Am I eligible to operate a CB station?  
95.404 (CB Rule 4) Do I need a license?  
95.405 (CB Rule 5) Where may I operate my CB station?

95.406 (CB Rule 6) Are there any special restrictions on the location of my CB station?

#### HOW TO OPERATE A CB STATION

95.407 (CB Rule 7) On what channels may I operate?  
 95.408 (CB Rule 8) How high may I put my antenna?  
 95.409 (CB Rule 9) What equipment may I use at my CB station?  
 95.410 (CB Rule 10) How much power may I use?  
 95.411 (CB Rule 11) May I use power amplifiers?  
 95.412 (CB Rule 12) What communications may be transmitted?  
 95.413 (CB Rule 13) What communications are prohibited?  
 95.414 (CB Rule 14) May I be paid to use my CB station?  
 95.415 (CB Rule 15) Who is responsible for communications I make?  
 95.416 (CB Rule 16) Do I have to limit the length of my communications?  
 95.417 (CB Rule 17) Do I identify my CB communications?  
 95.418 (CB Rule 18) How do I use my CB station in an emergency or to assist a traveler?  
 95.419 (CB Rule 19) May I operate my CB station transmitter by remote control?  
 95.420 (CB Rule 20) May I connect my CB station transmitter to a telephone?

#### OTHER THINGS YOU NEED TO KNOW

95.421 (CB Rule 21) What are the penalties for violating these rules?  
 95.422 (CB Rule 22) How do I answer correspondence from the FCC?  
 95.423 (CB Rule 23) What must I do if the FCC tells me that my CB station is causing interference?  
 95.424 (CB Rule 24) How do I have my CB station transmitter serviced?  
 95.425 (CB Rule 25) May I make any changes to my CB station transmitter?  
 95.426 (CB Rule 26) Do I have to make my CB station available for inspection?  
 95.427 (CB Rule 27) What are my station records?  
 95.428 (CB Rule 28) How do I contact the FCC?

### Subpart E—Technical Regulations

#### GENERAL PROVISIONS

95.601 Basis and purpose.  
 95.603 Type acceptance or certification required.  
 95.605 Type acceptance and certification procedures.  
 95.607 CB transmitter modification.

#### TECHNICAL STANDARDS

95.621 GMRS transmitter channel frequencies.  
 95.623 R/C transmitter channel frequencies.  
 95.625 CB transmitter channel frequencies.  
 95.627 FRS unit channel frequencies.  
 95.629 LPRS transmitter frequencies.  
 95.631 Emission types.  
 95.633 Emission bandwidth.  
 95.635 Unwanted radiation.  
 95.637 Modulation standards.  
 95.639 Maximum transmitter power.

#### TYPE ACCEPTANCE REQUIREMENTS

95.645 Control accessibility.  
 95.647 FRS unit and R/C transmitter antennas.  
 95.649 Power capability.  
 95.651 Crystal control required.  
 95.653 Instructions and warnings.  
 95.655 Frequency capability.

#### ADDITIONAL TYPE ACCEPTANCE REQUIREMENTS FOR CB TRANSMITTERS

95.665 [Reserved]  
 95.667 CB transmitter power.  
 95.669 External controls.  
 95.671 Serial number.  
 95.673 Copy of rules.

#### APPENDIX 1 TO SUBPART E—GLOSSARY OF TERMS

### Subpart F—Interactive Video and Data Service (IVDS)

#### GENERAL PROVISIONS

95.801 Scope.  
 95.803 IVDS description.  
 95.805 Permissible communications.

#### SYSTEM LICENSE REQUIREMENTS

95.811 License requirements.  
 95.813 Eligibility.  
 95.815 License application.  
 95.816 Competitive bidding proceedings.  
 95.817 Application for renewal of license.  
 95.819 License transferability.  
 95.821 Application for transfer of control.

#### SYSTEM REQUIREMENTS

95.831 Service requirements.  
 95.833 Construction requirements.  
 95.835 Station identification.  
 95.837 Station inspection.  
 95.839 Operation in the National Radio Quiet Zone.  
 95.841 Operation near a Commission monitoring facility.

#### TECHNICAL STANDARDS

95.851 Type acceptance.  
 95.853 Frequency segments.  
 95.855 Transmitter effective radiated power limitation.

## § 95.1

- 95.857 Emission standards.
- 95.859 Antennas.
- 95.861 Interference.
- 95.863 Duty cycle.

### Subpart G—Low Power Radio Service (LPRS).

#### GENERAL PROVISIONS

- 95.1001 Eligibility.
- 95.1003 Authorized locations.
- 95.1005 Station identification.
- 95.1007 Station inspection.
- 95.1009 Permissible communications.
- 95.1011 Channel use policy.
- 95.1013 Antennas.
- 95.1015 Disclosure policies.
- 95.1017 Labeling requirements.
- 95.1019 Marketing limitations.

AUTHORITY: Secs. 4, 303, 48 Stat. 1066, 1082, as amended; 47 U.S.C. 154, 303.

### Subpart A—General Mobile Radio Service (GMRS)

SOURCE: 48 FR 35237, Aug. 3, 1983, unless otherwise noted.

#### GENERAL PROVISIONS

#### § 95.1 The General Mobile Radio Service (GMRS).

(a) The *GMRS* is a land mobile radio service available to persons for short-distance two-way communications to facilitate the activities of licensees and their immediate family members. Each licensee manages a system consisting of one or more stations.

(b) Any entity eligible for licensing under this subpart is eligible to obtain an authorization in the 31.0 to 31.3 GHz band for personal communications, provided that the technical standards applicable to the band (as set out in part 94) are observed. (Individuals applying for stations in the 31.0 to 31.3 GHz band for personal communications shall use application Form 402.)

(c) The Interactive Video and Data Service (IVDS) is a two-way point-to-multipoint radio service intended for system licensees to provide information, products, and services, and to obtain responses from, subscribers in a specific service area. The rules for this service are contained in subpart F of this part.

[48 FR 35237, Aug. 3, 1983, as amended at 50 FR 7345, Feb. 22, 1985; 53 FR 47714, Nov. 25, 1988; 57 FR 8275, Mar. 9, 1992]

## 47 CFR Ch. I (10–1–96 Edition)

#### § 95.3 License required.

Before any station transmits on any channel authorized in the GMRS from any *point* (a geographical location) within or over the territorial limits of any area where radio services are regulated by the FCC, the responsible party must obtain a *license* (a written authorization from the FCC for a GMRS system).

[53 FR 47714, Nov. 25, 1988]

#### § 95.5 License eligibility.

An *individual* (one man or one woman) is eligible to obtain, renew and have modified a GMRS system license if that individual is 18 years of age or older and is not a representative of a foreign government. A *non-individual* (an entity other than an individual) is ineligible to obtain a new GMRS system license or to make a major modification to an existing GMRS system license (see § 95.71(e)). Certain non-individuals are eligible to renew existing GMRS system license (see § 95.89 (c) and (d)).

[53 FR 47714, Nov. 25, 1988; 53 FR 51625, Dec. 22, 1988]

#### § 95.7 Channel sharing.

(a) Channels or channel pairs are available to GMRS systems only on a shared basis and will not be assigned for the exclusive use of any licensee. All station operators and GMRS system licensees must cooperate in the selection and use of channels to reduce interference and to make the most effective use of the facilities.

(b) Licensees of GMRS systems suffering or causing harmful interference are expected to cooperate and resolve this problem by mutually satisfactory arrangements. If the licensees are unable to do so, the FCC may impose restrictions including specifying the transmitter power, antenna height, or area or hours of operation of the stations concerned. Further, the use of any frequency at a given geographical location may be denied when, in the judgment of the FCC, its use in that location is not in the public interest; the use of any channel or channel pair may

## Federal Communications Commission

## § 95.25

be restricted as to specified geographical areas, maximum power, or other operating conditions (see §95.71(d)).

[48 FR 35237, Aug. 3, 1983, as amended at 53 FR 47715, Nov. 25, 1988]

### CONSIDERATIONS WHEN PLANNING A GMRS SYSTEM

#### §95.21 GMRS system description.

(a) A *GMRS system* is one or more transmitting units used by station operators to communicate messages. A GMRS system is comprised of:

- (1) One or more station operators;
- (2) One mobile station consisting of one or more mobile units (see §95.23);
- (3) One or more land stations (optional); and
- (4) Paging receivers (optional).

(b) In certain areas, point-to-point GMRS systems may be comprised of fixed stations only (see §§95.47, 95.49 and 95.61).

(c) A GMRS system may be operated in:

- (1) *Simplex mode*. (Only one station operator can speak at a time.)
- (2) *Duplex mode*. (Two station operators can speak at the same time. One or more stations transmit on one channel. The other station(s) transmit(s) on the channel pair counterpart.)
- (3) A *combined simplex-duplex mode*. (E.g., a mobile relay system with mobile units operating in simplex mode on a channel pair.)

#### §95.23 Mobile station description.

(a) A *mobile station* is one or more units which transmit while moving or during temporary stops at unspecified points.

(b) A mobile station unit may transmit from any point within or over any areas where radio services are regulated by the FCC *except* where additional considerations apply (see §§95.37 through 95.49).

(c) A mobile station unit may transmit from an aircraft or ship, with the captain's permission, which is:

- (1) Within or over any area where radio services are regulated by the FCC *except* where additional restrictions apply; and
- (2) On or over international waters, if the unit is transmitting from an aircraft or ship of United States registry.

(d) A mobile station unit must not transmit from points within or over the territorial limits of any area where radio services are regulated only by:

- (1) A foreign government; or
- (2) A United States government agency other than the FCC.

[48 FR 35237, Aug. 3, 1983, as amended at 49 FR 4003, Feb. 1, 1984]

#### §95.25 Land station description.

(a) A *land station* is a unit which transmits only from:

- (1) An exact point as shown on the license; or
- (2) An unspecified point within an *operating area* (an area within a circle centered on a point chosen by the applicant) as shown on the license, for a *temporary period* (one year or less).

(b) The point from which every land station transmits must be within an area where radio services are regulated by the FCC.

(c) Each land station is classified according to its *communications points* (the other stations or paging receivers to which the station operator communicates messages). There are four *land station classes*:

- (1) Base station (see §95.55);
  - (2) Mobile relay station (see §95.57);
  - (3) Control station (see §95.59); and
  - (4) Fixed station (see §95.61).
- (d) A *small control station* is any control station which:

- (1) Has an antenna no more than 6.1 meters (20 feet) above the ground or above the building or tree on which it is mounted (see §95.51); and
- (2) *Is*: (i) South of Line A or west of Line C (see §95.37); or  
(ii) North of Line A or east of Line C, and the station transmits with no more than 5 watts *ERP* (effective radiated power).

(e) A *small base station* is any base station that:

- (1) Has an antenna no more than 6.1 meters (20 feet) above the ground or above the building or tree on which it is mounted (see §95.51); and
- (2) Transmits with no more than 5 watts *ERP*.

(f) A land station may be licensed to transmit as more than one station class. (*Example*: A land station is licensed as both a base station and a

control station. When it is transmitting as a base station its communication points are those of a base station (see §95.55). When it is transmitting as a control station its communication points are those of a control station (see §95.59).)

[48 FR 35237, Aug. 3, 1983, as amended at 53 FR 47715, Nov. 25, 1988; 53 FR 51625, Dec. 22, 1988]

**§95.27 Paging receiver description.**

A *paging receiver* is a unit capable of receiving the radio signals from a base station for the bearer to hear a *page* (someone's name or other identifier said in order to find, summon or notify him/her) spoken by the base station operator.

**§95.29 Channels available.**

(a) The licensee of the GMRS system must select the transmitting channel or channel pair for the stations in the GMRS system from the following lists:

(1) For a base station, mobile relay station, fixed station or mobile station, the following 462 MHz (megahertz) channels;

462.5500, 462.5750, 462.6000, 462.6250, 462.6500, 462.6750, 462.7000 and 462.7250.

(2) For a mobile station, control station or fixed station operated in the duplex mode, the following 467 MHz channels:

467.5500, 467.5750, 467.6000, 467.6250, 467.6500, 467.6750, 467.7000, and 467.7250.

(3) As of December 31, 1993, the 467 MHz channels may be used only to transmit communications through a mobile relay station and for remotely controlling a mobile relay station. As of December 31, 1993, no station in a GMRS system may transmit communications *directly* (not through a mobile relay station) on the 467 MHz channels.

(b) The FCC will normally assign only one channel or one *channel pair* (one 462 MHz channel and its counterpart 5 MHz spaced 467 MHz channel) to a GMRS system comprised of stations intended for operation in the simplex mode. A second channel or channel pair will be assigned at the request of the applicant.

(c) The FCC will normally assign only one channel pair to a GMRS sys-

tem comprised of stations intended for operation in the duplex mode. A second channel pair will be assigned at the request of the applicant.

(d) No GMRS system may be assigned more than two channels or channel pairs. Stations in certain GMRS systems may, however, also transmit on additional frequencies listed in the following paragraphs, in accord with the conditions specified.

(e) Mobile stations in a GMRS system licensed to an individual that is not specifically authorized for the 462.675 MHz/467.675 MHz channel pair may transmit on that channel pair with the following limitations:

(1) The communications must be for the purpose of soliciting or rendering assistance to a traveler, or for communicating in an emergency pertaining to the immediate safety of life or the immediate protection of property; and

(2) The frequency 467.675 MHz may be used only for the purposes of accessing and communicating through a mobile relay station transmitting on 462.675 MHz.

(f) Except for a GMRS system licensed to a non-individual, a mobile station or a small base station operating in the simplex mode may transmit on the following 462 MHz interstitial channels:

462.5625, 462.5875, 462.6125, 462.6375, 462.6625, 462.6875 and 462.7125.

These channels may be used only under the following conditions:

(1) Only voice type emissions may be transmitted;

(2) The station does not transmit one-way pages; and

(3) The station transmits with no more than 5 watts ERP.

(g) Fixed stations in GMRS systems authorized before March 18, 1968, located 160 kilometers (100 miles) or more from the geographic center of urbanized areas of 200,000 or more population as defined in the U.S. Census of Population, 1960, Vol. 1, Table 23, page 50 that were authorized to transmit on channels other than those listed in this section may continue to transmit on their originally assigned channels provided that they cause no interference to the operation of stations in any of

the part 90 private land mobile radio services.

[53 FR 47715, Nov. 25, 1988]

**§95.31 Overlap of GMRS systems.**

An entity may not have a base station or a mobile relay station for that entity's GMRS system within 64.4 kilometers (40 miles) of a base station or a mobile relay station for another GMRS system licensed to the same entity. Base stations and mobile relay stations licensed to the same entity in two different GMRS systems less than 64.4 kilometers (40 miles) apart which were authorized prior to October 16, 1983 are not subject to the provisions of this rule.

[48 FR 35237, Aug. 3, 1983, as amended at 49 FR 4003, Feb. 1, 1984]

**§95.33 Cooperative use of radio stations in the GMRS.**

(a) *Licensees* (a licensee is the entity to which the license is issued) of radio stations in the GMRS may share the use of their stations with other entities eligible in the GMRS, subject to the following conditions and limitations.

(1) The station to be shared must be individually owned by the licensee, jointly owned by the participants and the licensee, leased individually by the licensee, or leased jointly by the participants and the licensee.

(2) The licensee must maintain access to and control over all stations authorized under its license.

(3) A station may be shared only:

(i) Without charge;

(ii) On a non-profit basis, with contributions to capital and operating expenses including the cost of mobile stations and paging receivers prorated equitably among all participants; or

(iii) On a reciprocal basis, i.e., use of one licensee's stations for the use of another licensee's stations without charge for either capital or operating expenses.

(4) All sharing arrangements must be conducted in accordance with a written agreement to be kept as part of the station records.

(b) Participants in a cooperatively shared GMRS mobile relay or base station may obtain a license for their own mobile station(s), provided that the li-

censee of the shared GMRS station consents in writing to the issuance of such authorization.

**§95.35 Multiple licensing of radio transmitting equipment in the GMRS.**

Two or more persons licensed in the GMRS may use the same transmitting equipment under the following terms and conditions:

(a) Each licensee complies with the general operating requirements set out in §§95.171 through 95.181 of the rules; and

(b) Each licensee must have access to the transmitter for which the licensee is authorized.

**§95.37 Considerations near the Canadian border.**

The United States and the Government of Canada coordinate channel assignments to certain radio stations in areas along their common borders north of Line A and east of Line C. (See §1.955 of the FCC Rules.)

**§95.39 Considerations near FCC monitoring facilities.**

The FCC may impose additional restrictions on a land station in a GMRS system if it is at a point within 4.8 kilometers (3 miles) of an FCC monitoring facility and the station's transmissions degrade, obstruct, or repeatedly interrupt the operation of the equipment at the FCC monitoring facility. Before applying for license to put a land station at such a point, or before applying to change anything in a station already licensed for such a point, you should consult the FCC by writing to the Chief, Compliance and Information Bureau, Federal Communications Commission, Washington, DC 20554.

[53 FR 47715, Nov. 25, 1988, as amended at 60 FR 50123, Sept. 28, 1995; 61 FR 8478, Mar. 5, 1996]

**§95.41 Considerations in the National Radio Quiet Zone.**

(a) The FCC may impose additional restrictions on a land station in a proposed GMRS system, or on one in a GMRS system proposed for modification, if the station is proposed for or located at a point within the *National Radio Quiet Zone* (an area within the

States of Maryland, Virginia and West Virginia). The Zone is the area bounded by:

- (1) 39°15' N. on the North;
- (2) 78°30' W. on the East;
- (3) 37°30' N. on the South; and
- (4) 80°30' W. on the West.

(b) When applying for a license to put a land station at a point in the National Radio Quiet Zone, or when applying to change certain details in a station already licensed for such a point, the applicant must send a notice to the National Radio Astronomy Observatory (see §95.79).

(c) Restrictions may be imposed if the National Radio Astronomy Observatory files an objection with the FCC within 20 days after the application is filed with the FCC.

#### §95.43 Environmental considerations.

An application for AMRS system that includes a local station which may have a significant impact upon the environment, as specified in §1.1307 of this chapter, must be accompanied by an environmental assessment as set forth in §1.1311 of this chapter.

[55 FR 20398, May 16, 1990]

#### §95.45 Considerations on Department of Defense land.

The Department of Defense may impose additional restrictions on a station transmitting on its land. (Before applying to place or modify a station at such a point, an applicant should consult with the commanding officer in charge of the land.)

#### §95.47 Considerations in large urban areas.

(a) No fixed station may be at any point within a large urban area.

(b) A control station at a point within a large urban area must have:

- (1) A directional antenna (at least 15 decibel front-to-back ratio); and
- (2) No more transmitter power than determined by a *control station power test* (a test to determine the appropriate transmitter power (see appendix A)).

(c) Where these rules use the term *large urban area*, it means a circular region extending out 121 kilometers (75 miles) in all directions around the geographic center of certain cities.

(d) The large urban areas and their geographic centers are shown in appendix B.

(e) Control stations and fixed stations authorized before October 16, 1983 located beyond 121 kilometers (75 miles) of the geographic center of urbanized areas of 200,000 or more population as defined in the U.S. Census of Population, 1960, Vol. 1, table 23, page 50, are not subject to the restrictions of this rule section.

#### §95.49 Considerations near large urban areas.

(a) A fixed station at a point near a large urban area must have:

- (1) A directional antenna (at least 15 decibel front-to-back ratio); and
- (2) No more than 15 watts transmitter power output.

(b) Where these rules use the term *near a large urban area*, it means the region within a circular band around a large urban area. The band is 40 kilometers (25 miles) wide. It begins at the rim of the large urban area, and extends out 161 kilometers (100 miles) around the geographic center of the city.

(c) Fixed stations authorized before October 16, 1983 located beyond 161 kilometers (100 miles) of the geographic center of urbanized areas of 200,000 or more population as defined in the U.S. Census of Population, 1960, Vol. 1, table 23, page 50, are not subject to the restrictions of this rule section.

#### §95.51 Antenna height.

(a) A land station *antenna* (the land station's radiating structure (for transmitting, receiving or both), including the tower, mast or pole supporting it and everything attached to the structure) must not be a hazard to aircraft. The licensee of a GMRS system must get FCC permission (see §95.83) before the uppermost tip of an antenna may be higher than normally allowed in paragraphs (b), (c) and (d) of this section.

(b) Regardless of any other requirement of this section, an antenna may always be at least:

- (1) 6.1 meters (20 feet) above the ground or above the building or tree upon which the antenna is mounted; or



(2) Equal to the height of an existing antenna to which the land station antenna is attached.

(c) The antenna may be as high as 61 meters (200 feet) above the ground, unless it will be within 6.1 kilometers (20,000 feet) of an airport or heliport.

(d) If the antenna is near an airport or heliport listed in the FAA's (Federal Aviation Administration's) Airport Facilities Directory, or near an airport or heliport operated by the Department of Defense, it must not be higher than:

(1) One meter higher than the airport elevation for every 100 meters from the nearest runway if the runway is longer than one kilometer (3,281 feet), and is within 6.1 kilometers (20,000 feet) of the antenna; or

(2) Two meters higher than the airport elevation for every 100 meters from the nearest runway if the runway is no longer than one kilometer (3,281 feet), and is within 3.1 kilometers (10,000 feet) of the antenna; or

(3) Four meters higher than the heliport elevation for every 100 meters from the nearest landing pad if the pad is within 1.5 kilometers (5,000 feet) of the antenna.

(e) If the FCC grants permission to put an antenna higher than normally allowed in paragraphs (b), (c) and (d) of this section, the licensee may have to mark the antenna with bright paint and light it up at night (see part 17 of the FCC Rules).

(f) The antenna for a small base stations or for a small control station must not be more than 6.1 meters (20 feet) above the ground or above the building or tree on which it is mounted.

[48 FR 35237, Aug. 3, 1983, as amended at 53 FR 47715, Nov. 25, 1988]

**§95.53 Mobile station communication points.**

(a) A mobile station unit may transmit communications directly to:

(1) Other mobile station units in the same GMRS system;

(2) Mobile station units in any other GMRS system;

(3) A base station in the same GMRS system; and

(4) A base station in any other GMRS system;

(b) A mobile station unit may transmit communications through a mobile relay station in the same GMRS system to:

(1) Other mobile station units in the same GMRS system;

(2) Control stations in the same GMRS system; and

(3) Mobile station units in any other GMRS system.

(c) A mobile station unit authorized to transmit on a channel assigned to a mobile relay station in another GMRS system may transmit communications through that mobile relay station to:

(1) Mobile station units in the other GMRS system; and

(2) Control stations in the other GMRS system.

(d) A mobile station unit in a GMRS system licensed to an individual authorized to transmit on a channel assigned to a mobile relay station in another GMRS system may transmit communications through that mobile relay station with the permission of the licensee of the other GMRS system to:

(1) Other mobile station units in the same GMRS system; and

(2) Mobile station units in another GMRS system having permission to transmit communications through the mobile relay station.

(e) A mobile station unit must not transmit communications to:

(1) Any fixed station;

(2) Any control station, directly;

(3) Any station in the Amateur Radio Service;

(4) Any unauthorized station; or

(5) Any foreign station.

(f) A mobile station unit must not transmit communications through a mobile relay station in another GMRS system, for retransmission to:

(1) Other mobile station units in its own GMRS system, unless:

(i) The mobile station units are in a GMRS system licensed to an individual; and

(ii) The licensee of the other GMRS system has given permission to use the mobile relay station for this purpose.

(2) A control station in its own GMRS system; or

(3) Any station in any GMRS system other than the system which includes the mobile relay station.

(g) A mobile station unit may transmit communications as a radio control link (see §95.127) to a remotely controlled station.

[48 FR 35237, Aug. 3, 1983, as amended at 53 FR 47715, Nov. 25, 1988]

**§95.55 Base station communication points.**

(a) A base station may transmit communications directly to:

- (1) Mobile station units in the same GMRS system;
- (2) Mobile station units in any other GMRS system; and
- (3) Paging receivers in the same GMRS system.

(b) A base station must not transmit communications to:

- (1) Any mobile relay station;
- (2) Any base station;
- (3) Any paging receiver not in the same GMRS system;
- (4) Any fixed station;
- (5) Any control station;
- (6) Any station in the Amateur Radio Service;
- (7) Any unauthorized station; or
- (8) Any foreign station.

**§95.57 Mobile relay station communication points.**

(a) A mobile relay station in a GMRS system may *automatically* (without immediate thought or action by the station operator) retransmit communications between:

- (1) A mobile station unit in the same GMRS system and:
  - (i) Another mobile station unit in the same GMRS system; or
  - (ii) A control station in the same GMRS system.
- (2) A mobile station unit in any other GMRS system and:
  - (i) Another mobile station unit in the same GMRS system as the mobile relay station; or
  - (ii) A control station in the same GMRS system as the mobile relay station.

(b) A mobile relay station in a GMRS system must not automatically retransmit communications between:

- (1) A mobile station unit in any other GMRS system *and* another unit of the same mobile station, unless:
  - (i) The other GMRS system is licensed to an individual; and

(ii) The licensee of the GMRS system with the mobile relay station has given permission to use the mobile relay station for this purpose;

- (2) Any control station *and* any other control station;
  - (3) Any other mobile relay station *and* any station;
  - (4) Any base station *and* any station;
- or
- (5) Any fixed station *and* any station.

[48 FR 35237, Aug. 3, 1983, as amended at 53 FR 47716, Nov. 25, 1988]

**§95.59 Control station communication points.**

(a) A control station may transmit communications as a radio control link (see §95.127) to a remotely controlled station.

(b) A control station may transmit communications through a mobile relay station to:

- (1) Mobile station units in the same GMRS system as the control station; and
- (2) Mobile station units in any other GMRS system.

(c) A control station must not transmit communications to any other station.

**§95.61 Fixed station communication points.**

(a) A fixed station may transmit communications from the point authorized for it on the license to another fixed station in the same GMRS system at the point authorized for it on the license.

(b) A fixed station must not transmit communications to any other station.

**APPLYING FOR A GMRS SYSTEM LICENSE**

**§95.71 Applying for a new or modified license.**

(a) An individual applies for a license for a new GMRS system by filling out an application form and attaching all additional information required. An individual applies to modify a license for an existing GMRS system using the same form and in the same manner as applying for a new GMRS system. Individuals should submit their applications, together with the filing fee, to the address specified in the Private Radio Services Fee Filing Guide.

(b) An applicant for a General Mobile Radio Service system license, sharing a multiply-licensed mobile relay station, may operate the system for a period of 180 days, under a Temporary Permit, evidenced by a properly-executed certification made on FCC Form 574-T, after mailing FCC Form 574 to the Commission.

(c) The application will be returned to the applicant if it is defective. An application is *defective* if:

(1) The form is not completely filled out;

(2) All necessary additional information is not included; or

(3) All necessary certifications have not been made (see, e.g., §95.75 (g)(2), (o) and (p)).

(d) The Commission may, without a hearing, grant an application in part or subject to terms or conditions or with privileges other than those requested. Such an action is presumed to be a grant of the application unless the applicant files a written rejection of the grant as made within 30 days from the date of the grant or the effective date of the grant, whichever is later. If the Commission receives rejection of such a grant, the Commission will vacate its original action and will set the application for hearing.

(e) A non-individual may not obtain a new GMRS system license. A non-individual that held a GMRS system license issued before July 31, 1987, may not make the following major modifications:

(1) Change the area of operation of the GMRS system;

(2) Add any stations to the GMRS system;

(3) Increase the number of units of the mobile station;

(4) Change the location of any land station in the GMRS system;

(5) Add one or more channels or channel pairs and/or change the assigned channel(s) or channel pair(s);

(6) Increase the transmitter power of an station in the GMRS system; or

(7) Increase the height of a station antenna in the GMRS system.

(f) A GMRS system licensee may notify the FCC of a change of name or a change of mailing address by sending a letter to the Federal Communications Commission, 1270 Fairfield Road, Get-

tysburg, PA 17325-7245. This does not, however, permit GMRS system license transferability (see §95.109). Nor does this suffice for corporate transfer of control—the provisions of §95.111 apply instead.

[43 FR 54791, Nov. 22, 1978, as amended at 52 FR 10232, Mar. 31, 1987; 53 FR 47716, Nov. 25, 1988; 53 FR 51625, Dec. 22, 1988; 55 FR 51908, Dec. 18, 1990]

#### §95.72 Applying for an STA or waiver of the rules.

Applicants requesting an STA or waiver of the rules should submit their requests, together with the filing fee, to the address specified in the Wireless Telecommunications Bureau Fee Filing Guide.

[60 FR 50123, Sept. 28, 1995]

#### §95.73 System licensing.

(a) Application for a license for a new GMRS system or application to modify a licensed GMRS system is made on Form 574. The applicant must follow the *Instructions for Completion of FCC Form 574* (available at FCC Field Offices).

(b) One set of forms must be used for each system the applicant wants the FCC to license.

(c) One form must be used to apply for the following stations in a GMRS system:

(1) The mobile station;

(2) All small base stations (see §95.25(e));

(3) All small control stations (see §95.25(d)); and

(4) All other land stations (at no more than 6 locations).

(d) An additional form must be used to apply for every six land stations in a GMRS system that cannot be listed in the preceding form.

(e) Form 574-T, Temporary Permit for a General Mobile Radio Service System, should be used if applicant is eligible and desires to operate the station pending the processing of the application. (See also §95.71(b).)

[48 FR 35237, Aug. 3, 1983, as amended at 53 FR 47716, Nov. 25, 1988]

**§ 95.75 Basic information.**

The following information is required in all applications for a license for a new or modified GMRS system:

- (a) Applicant's name (see § 95.5);
- (b) Applicant's *mailing address* (an address in the United States where mail from the FCC can be received);
- (c) Transmitting channel or channel pair requested (see § 95.29);
- (d) Station class;
- (e) Number of transmitter units in a mobile station (see § 95.23);
- (f) Number of land stations in each class (see § 95.25);
- (g) Transmitter power as follows:
  - (1) Transmitter output power in watts for all stations.
  - (2) Station ERP in watts for all stations other than mobile stations, small base stations and small control stations.
- (h) Each land station point (except small base stations and small control stations):
  - (1) Latitude and longitude within one second; and
  - (2) Street address (if none, local directions to the station);
    - (i) Each control point for each remotely controlled land station (see § 95.127), including small base stations and small control stations:
      - (1) Street address (if none, local directions to the control point); or
      - (2) Call sign of any control station already licensed to the applicant for that point;
    - (j) Antenna height (see § 95.51) and antenna ground elevation for each land station, except for small base stations and small control stations;
  - (k) Communication services (see § 95.101(c)) the proposed GMRS system would provide to, or receive from, any other individual or entity;
    - (l) Age eligibility statement (where required—see § 95.5);
    - (m) Area of operation;
    - (n) *Emission designator*. In the GMRS, emission F3E will be considered to include use of a *selective calling tone, or a tone or digitally operated squelch* (a tone code used to address a particular station) in conjunction with voice communications;
    - (o) Foreign government certification, if applicable (see § 95.5);

- (p) Frequency claim waiver certification, if applicable; and
- (q) Applicant's signature (see § 95.87).

[48 FR 35237, Aug. 3, 1983, as amended at 49 FR 4003, Feb. 1, 1984; 53 FR 47716, Nov. 25, 1988]

**§ 95.77 Additional information for GMRS systems with land stations at four or more locations.**

- (a) An application for a new or modified GMRS system having land stations (except for small control stations or small base stations) at 4 or more locations must include a *functional system diagram* (a drawing showing details of the GMRS system, including the points between which communications with other stations in the system will be exchanged.)

(b) [Reserved]

- (c) A copy of the functional system diagram must be kept as part of the GMRS system records (§ 95.113).

[48 FR 35237, Aug. 3, 1983, as amended at 53 FR 47716, Nov. 25, 1988]

**§ 95.79 Additional information for stations in the National Radio Quiet Zone.**

An application for a license for a new or modified GMRS system having a land station at a point within the National Radio Quiet Zone (see § 95.41) must:

- (a) Send a notice to:

*Director, National Radio Astronomy Observatory  
P.O. Box 2  
Green Bank, WV 24944*

- (b) Provide the following details about the proposed station in the notice:

- (1) Antenna point (latitude and longitude);
- (2) Antenna height;
- (3) Antenna directivity;
- (4) Transmitting channel(s);
- (5) Emission; and
- (6) Transmitter output.

- (c) Include in the application to the FCC the date the notice was sent to the Observatory.

**§95.83 Additional information for stations with antennas higher than normally allowed.**

(a) An applicant for a license for a new or modified GMRS system seeking permission to have a land station antenna higher than normally allowed (see §95.51) must:

(1) Request (on FCC Form 574) an antenna height greater than normally allowed; and

(2) Notify the Federal Aviation Administration (on FAA Form 7460-1) that the antenna would be higher than normally allowed.

(3) Register the structure by submitting FCC Form 854. The requirements for antenna structure registration, painting, and lighting are found in part 17 of this chapter.

(b) Each base station and each control station with an antenna height greater than 6.1 meters (20 feet) must be separately identified on Form 574 (see §§95.25 (d) and (e) and 95.51(f)).

[48 FR 35237, Aug. 3, 1983, as amended at 53 FR 47716, Nov. 25, 1988; 61 FR 4369, Feb. 6, 1996]

**§95.85 Additional information for stations near United States borders.**

For a new or modified GMRS system having a land station at a point north of line A, east of line C, or at any point close to any United States border where interference to a station in another country could occur, an applicant may include additional data on FCC Form 574-B if the land station:

(a) Does not have vertical polarization;

(b) Does not have an omnidirectional azimuth;

(c) Has an associated control station with other than a directional antenna having its azimuth of maximum radiation directed towards the land station;

(d) Has an associated control station with other than 20 degrees beamwidth; or

(e) Is part of a GMRS system that includes stations or units intended for communication with stations or units in other GMRS systems or in other radio services.

Provision of this information will enable the Commission to seek greater

interference protection for the station from foreign stations.

[49 FR 4003, Feb. 1, 1984]

**§95.87 Who may sign applications.**

See part 1 of this chapter, §1.913, for practices and procedures governing signatures on license applications.

[58 FR 21407, Apr. 21, 1993]

**§95.89 Renewing a license.**

(a) The licensee of a GMRS system may apply to the FCC to renew the license for another term (see §95.105) by filling out FCC Form 574-R (or FCC Form 405-A when the licensee has not gotten FCC Form 574-R within 30 days of the expiration of the license), and sending it, together with the filing fee, to the address specified in the Private Radio Services Fee Filing Guide (unless the licensee is a governmental entity, in which case the renewal application should be sent to the Federal Communications Commission, 1270 Fairfield Road, Gettysburg, PA 17325-7245).

(b) If the renewal application is sent to the FCC before the existing license term expires, the renewal application is timely filed. Except for GMRS systems whose licenses may not be renewed (see §95.89 (c)(3) and (d)), stations in a GMRS system whose application is timely filed may continue to transmit under the expired license until the FCC acts on the renewal application. A copy of the renewal application sent to the FCC must be kept in the GMRS system records (see §95.113) until the renewed license, or notification of other FCC action, is received.

(c) A GMRS system licensed to a non-individual before July 31, 1987, is eligible to renew that license and all subsequent licenses based upon it if:

- (1) The non-individual is:
  - (i) A partnership, and each partner is 18 years of age or older;
  - (ii) A corporation;
  - (iii) An association;
  - (iv) A state, territorial or local government unit; or
  - (v) Other legal entity;
- (2) The non-individual is not:
  - (i) A foreign government;
  - (ii) A representative of a foreign government; or

(iii) A federal government agency; and

(3) The licensee has not been granted any of the modifications to its GMRS system license specified in §95.71(e).

(d) A GMRS system licensed to a non-individual on or after July 31, 1987, may not be renewed.

(e) If a GMRS system license is allowed to expire, the former licensee may file an application to reinstate the expired license within six months after the expiration date. The application to reinstate must be accompanied by a renewal application. An expired GMRS system license for which a timely renewal application has not been filed is not valid. No station of such a GMRS system may transmit until the licensee has received a new GMRS system license based on the late-filed renewal application.

[53 FR 47716, Nov. 25, 1988, as amended at 55 FR 51909, Dec. 18, 1990]

MANAGING A GMRS SYSTEM

**§95.101 What the license authorizes.**

(a) A license authorizes the licensee to manage the GMRS system only as:

- (1) The Rules require;
- (2) The license specifies;
- (3) Proposed by the entity in the license application; and
- (4) Shown on the functional system diagram (where applicable).

(b) The license does not authorize operation as a common carrier or communication of messages for pay.

(c) If the licensee is a corporation and the license so indicates, it may use its GMRS system to furnish non-profit radio communication service to its parent corporation, to another subsidiary of the same parent, or to its own subsidiary. Such use is not subject to the cooperative use provisions of §95.33.

**§95.103 Licensee duties.**

(a) The licensee is responsible for the proper operation of the GMRS system at all times.

(b) The licensee must have access to the station equipment and be able to disable it. A licensee using multiple licensed transmitting equipment may satisfy this requirement by entering an arrangement with other licensees using the same equipment to select one of

their number to have primary access responsibility.

(c) When the information about the licensee stated on the license changes, the licensee must take the following step(s):

(1) The licensee must notify the FCC in writing in the event of a name or mailing address change (see §95.117(b)). The notice must show the name and mailing address as they appear on the license, the station call sign(s), and the new name or new mailing address. A copy of the notice must be kept as part of the GMRS system records (see §95.113). (FCC Forms 405-A or 574-R may be used for this purpose.)

(2) If the status of a non-individual GMRS system licensee changes (for example, when a corporation is dissolved and a new corporation stands in its place, or a partnership becomes a corporation), the licensee must send the license to the FCC for cancellation (see §95.117(b)).

The former licensee may not operate until the FCC has approved a license for the system in the name of the new entity.

[48 FR 35237, Aug. 3, 1983, as amended at 53 FR 47717, Nov. 25, 1988]

**§95.105 License term.**

A license for a GMRS system is usually issued for a 5-year term. (FCC prints the expiration date on the license.)

**§95.107 Keeping the license.**

(a) The licensee must keep the license document until:

- (1) The license expires; or
- (2) The license is terminated by the FCC; or
- (3) The licensee obtains a different license for the GMRS system.

(b) The license must be kept as part of the GMRS system records (see §95.113).

(c) The license may be photocopied for any lawful purpose.

(d) If the license is lost, the licensee must request a duplicate document from the FCC. The request for a duplicate license, together with the filing fee, should be sent to the address specified in the Wireless Telecommunications Bureau Fee Filing Guide.

(e) If the license is no longer desired, it must be sent to the FCC (see § 95.117(b)(6)) with a written request that it be cancelled. (Forms 405-A or 574-R may be used for this purpose.)

[48 FR 35237, Aug. 3, 1983, as amended at 60 FR 50123, Sept. 28, 1995]

**§ 95.109 License not transferable.**

(a) The licensee must not transfer, assign, sell or give the license for a GMRS system to any other entity except in accordance with the provisions of § 95.111.

(b) If the licensee sells or gives away the GMRS system equipment, the new owner must obtain a new license before using it (see § 95.71), unless the new owner intends to use the equipment with an already licensed GMRS system.

**§ 95.111 Transfer of control of a corporation.**

If the licensee of a GMRS system is a corporation, and there is a change in the control of the corporation, the licensee must request consent for the change of control from the FCC by filling out Form 703 and sending it, together with the filing fee, to the address specified in the Wireless Telecommunications Bureau Fee Filing Guide. The FCC document granting such consent must be kept as part of the GMRS system records (see § 95.113).

[56 FR 51909, Dec. 18, 1990, as amended at 60 FR 50123, Sept. 28, 1995]

**§ 95.113 System records.**

(a) The licensee must keep records for the GMRS system for the license term (see § 95.105), except that the licensee need not keep authorizations which have expired.

(b) GMRS *system records* include the following documents (where applicable):

- (1) The license (see § 95.107);
- (2) [Reserved]
- (3) Copies of letters from the licensee to the FCC concerning name or mailing address changes (see § 95.103);
- (4) Copies of answers to discrepancy notices;
- (5) An STA or waiver of these rules;

(6) A copy of any renewal application submitted to the FCC and not yet acted upon (see § 95.89(b));

(7) A copy of the measurements and calculations (see appendix A) made during a control station power test (see § 95.47);

(8) A copy of a functional system diagram (see § 95.77);

(9) A copy of the agreement under which any station in the GMRS system is cooperatively shared (see § 95.33);

(10) A copy of the FCC consent to a licensee corporation's change in its corporate control (see § 95.111); and

(11) A temporary permit.

[48 FR 35237, Aug. 3, 1983, as amended at 53 FR 47717, Nov. 25, 1988]

**§ 95.115 Station inspection.**

If an authorized FCC representative requests to inspect any station in a GMRS system, the licensee or station operator must make the station available. If an authorized FCC representative requests to inspect the GMRS system records (see § 95.113), the licensee must make them available.

**§ 95.117 Where to contact the FCC.**

(a) Write to:

*The nearest FCC Field Office*

(1) For application forms (see §§ 95.73 and 95.87);

(2) For instruction forms (see § 95.73);

(3) To complain about interference;

or

(4) To find out if the FCC has type-accepted a certain transmitter for use in the GMRS (see § 95.129).

(b) Write to: Federal Communications Commission, Attention: GMRS, 1270 Fairfield Road, Gettysburg, PA 17325-7245.

(1) To ask a question about an application or about these Rules;

(2)-(3) [Reserved]

(4) To notify the FCC of a new name or mailing address (see § 95.103);

(5) [Reserved]

(6) To return a license to the FCC for cancellation (see §§ 95.103 and 95.107).

(7) [Reserved]

(c) [Reserved]

[48 FR 35237, Aug. 3, 1983, as amended at 53 FR 47717, Nov. 25, 1988; 55 FR 51909, Dec. 18, 1990]

**§ 95.119 Station identification.**

(a) Except as provided in paragraph (e) of this section, every station in a GMRS system and every mobile station unit must transmit a station identification:

(1) Following the transmission of communications or a series of communications; and

(2) Every 15 minutes during a long transmission.

(b) The station identification is the call sign assigned to:

(1) The GMRS system; or

(2) The station in the GMRS system transmitting communications.

(c) A unit number may be included after the call sign in the identification.

(d) The station identification must be clearly transmitted in:

(1) Voice in the English language, with each letter and digit separately and distinctly transmitted (letters may be said using a phonetic alphabet); or

(2) International Morse code telegraphy with a keyed tone (400 to 2,000 Hertz) between 8.34 and 20.85 baud (ten to twenty-five words per minute). The transmitted frequency deviation must be between 1,500 and 2,500 Hertz. Should delayed or periodic activation of automatic Morse code identification equipment interrupt the communications of another co-channel licensee, the Commission may require the use of equipment which will inhibit automatic station identification when co-channel communications are in progress.

(e) A station need not identify its transmissions if it automatically retransmits communications from another station which are properly identified.

**§ 95.121 Transmitting channel.**

Each station in a GMRS system must transmit only on the channel(s) or channel pair(s) (see §§ 95.7 and 95.29) printed on the license for that station, or authorized by these Rules for use by that station (see § 95.29 (e) and (f)).

[53 FR 47717, Nov. 25, 1988]

**§ 95.123 Sharing a station or sharing equipment.**

Every station in a GMRS system which is cooperatively shared (see § 95.33) must be managed by the li-

censee in accordance with the written agreement and in accordance with the provisions of § 95.33. Licensees sharing multiply licensed equipment must do so in accordance with the provisions of § 95.35.

**§ 95.125 Station control point.**

(a) Each station in a GMRS system must have a *control point* (where the station operator can perform the required duties (see § 95.173)).

(b) The control point for each station must be at that station, unless the license authorizes the station to be controlled from a remote point.

**§ 95.127 Controlling a station from a remote point.**

(a) A station operator in a GMRS system may control the station from a remote point through a *control link* (a connection between the remote control point and the remotely controlled station). The control link must be either:

(1) A wireline control link solely for purposes of transmitter control (see § 95.181(i)(13)); or

(2) A radio control link.

(b) The remotely controlled station must not make unauthorized transmissions.

(c) The station operator must perform the required duties (see § 95.173) when controlling the station from a remote point the same as when controlling it locally at the station point. Should the control link fail to function so that the station operator cannot perform the required duties, the remotely controlled station must not transmit.

(d) The FCC does not consider a station in a GMRS system as being remotely controlled if the connection is a wireline or mechanical control link, and the station and its control point are both:

(1) On the same vehicle; or

(2) At the same street address, or within 152 meters (500 feet) of each other.

(e) Any device used to establish a wireline control link which is attached to the public switched telephone network after April 1, 1976 must be registered with the FCC and must comply with the standards incorporated in a registration program to protect the



public switched telephone network from harm (see part 68 of the FCC Rules).

**§95.129 Station equipment.**

(a) Every station in a GMRS system must use transmitters the FCC has type-accepted for use in the GMRS. Write to any FCC Field Office to find out if a particular transmitter has been type-accepted for the GMRS. All station equipment in a GMRS system must comply with the technical rules in part 95, subpart E of these rules.

(b) No transmitter may be used at a station in a GMRS system which:

(1) Is not FCC type-accepted for use in the GMRS;

(2) Has been internally modified to make it different from the FCC type-accepted model (see §95.133); or

(3) [Reserved]

(c) A land station in a GMRS system must use a directional antenna if it is a:

(1) Control station at a point within a large urban area (see §95.47); or

(2) Fixed station at a point near a large urban area (see §95.49).

(d) Every small base station and every small control station must use an antenna no more than 6.1 meters (20 feet) high (see §95.25 (d) and (e)).

(Secs. 4(i) and 303(r), Communications Act of 1934, as amended, 47 U.S.C. 154(i) and 303(r), and sec. 553 of the Administrative Procedures Act, 5 U.S.C. 553)

[48 FR 35237, Aug. 3, 1983, as amended at 49 FR 20672, May 16, 1984; 53 FR 47717, Nov. 25, 1988]

**§95.131 Servicing station transmitters.**

(a) The GMRS system licensee shall be responsible for the proper operation of all stations in the GMRS system at all times and is expected to provide for observations, servicing and maintenance as often as may be necessary to ensure proper operation.

(b) Except as provided in paragraph (c) of this section, test signals during internal adjustments to a station transmitter must be made using a non-radiating simulated antenna.

(c) Brief test signals using a radiating antenna may be transmitted to adjust the antenna to the station transmitter or to detect or measure spurious radiation. These test transmissions

must not be longer than one minute during any five-minute period. These test transmissions shall not interfere with communications already in progress on the operating frequency, and shall be properly identified as required, but may be otherwise unmodulated as appropriate.

(Secs. 4(i) and 303(r), Communications Act of 1934, as amended, 47 U.S.C. 154(i) and 303(r), and sec. 553 of the Administrative Procedures Act, 5 U.S.C. 553)

[48 FR 35237, Aug. 3, 1983, as amended at 49 FR 20672, May 16, 1984; 53 FR 47717, Nov. 25, 1988]

**§95.133 Modification to station transmitters.**

(a) No internal changes may be made in a transmitter used in a station in a GMRS system to make the transmitter different from the FCC type-accepted model (see §95.129).

(b) One FCC type-accepted model may be converted to another FCC type-accepted model if the conversion is done:

(1) By the original manufacturer of the transmitter.

(2) In accordance with the original manufacturer's instructions.

(Secs. 4(i) and 303(r), Communications Act of 1934, as amended, 47 U.S.C. 154(i) and 303(r), and sec. 553 of the Administrative Procedures Act, 5 U.S.C. 553)

[48 FR 35237, Aug. 3, 1983, as amended at 49 FR 20672, May 16, 1984; 53 FR 47717, Nov. 25, 1988]

**§95.135 Maximum authorized transmitting power.**

(a) No station may transmit with more than 50 watts output power.

(b) A control station at a point within a large urban area must not transmit with more output power than the licensee determines by a test (see §95.47 and appendix A). The licensee must keep a copy of the measurements and calculations made during this test as part of the GMRS system records (see §95.113).

(c) A small control station at a point north of Line A or east of Line C must transmit with no more than 5 watts ERP.

(d) A fixed station at a point near a large urban area must transmit with

§ 95.137

no more than 15 watts output power (see § 95.49).

(e) A small base station must transmit with no more than 5 watts ERP.

[48 FR 35237, Aug. 3, 1983, as amended at 53 FR 47717, Nov. 25, 1988]

**§ 95.137 Moving a small base station or a small control station.**

(a) A small base station (see § 95.25(e)) or a small control station (see § 95.25(d)) in a GMRS system may be moved from the point specified on the license to any other point where radio services are regulated by the FCC.

(b) The licensee must file an application to modify the GMRS system (see § 95.71) to show the new point within 30 days after the small base station or the small control station is moved.

[53 FR 47717, Nov. 25, 1988]

**§ 95.139 Adding a small base station or a small control station.**

(a) Except for a GMRS system licensed to a non-individual, one or more small base stations or a small control station may be added to a GMRS system at any point where radio services are regulated by the FCC.

(b) The licensee must file an application to modify the GMRS system (see § 95.71) within 30 days after each small base station or small control station is added.

(c) Non-individual licensees may not add any small base station or small control stations to their GMRS systems.

[53 FR 47717, Nov. 25, 1988]

**§ 95.141 Interconnection prohibited.**

No station in a GMRS system may be interconnected to the public switched telephone network except as and in accordance with the requirements and restrictions applied to a wireline control link (see § 95.127).

[53 FR 47717, Nov. 25, 1988]

**§ 95.143 Managing a GMRS system in an emergency.**

(a) The stations in a GMRS system must cease transmitting when the station operator of any station on the same channel is communicating an *emergency message* (concerning the im-

mediate protection of property or the safety of someone's life).

(b) If necessary to communicate an emergency message from a station in a GMRS system, the licensee may permit:

(1) Anyone to be the station operator (see § 95.179); and

(2) The station operator to communicate the emergency message to any radio station.

OPERATING A GMRS STATION

**§ 95.171 Station operator at control point.**

When a station in a GMRS system is transmitting, it must have a station operator. The station operator must be at the control point (see § 95.125) for that station. The same person may be the operator for more than one station at the same time.

**§ 95.173 Station operator duties.**

The *station operator*:

(a) Communicates messages (see § 95.181);

(b) *Controls* the station by:

(1) Causing it to transmit and to cease transmitting;

(2) Taking all necessary and reasonable precautions to assure that unauthorized or improper operations do not occur;

(3) Refraining from making any transmissions that may have the reasonably anticipated effect of causing improper operation of others' equipment; and

(4) In cases of recurrent interference, obeying any Commission-imposed additional requirements or restrictions.

**§ 95.175 Cooperation in sharing channels.**

The station operator must cooperate in *sharing* each channel with station operators of other stations by:

(a) Monitoring the channel before initiating transmissions;

(b) Waiting until ongoing communications are completed before initiating transmissions;

(c) Engaging in only permissible communications (see § 95.181); and

(d) Limiting transmissions to the minimum practicable transmission time.

[48 FR 35237, Aug. 3, 1983, as amended at 53 FR 47717, Nov. 25, 1988]

**§95.177 Responsibility for station operator's communications.**

The licensee is responsible for all communications made by station operators in the GMRS system. (The licensee should be certain every station operator understands and complies with these Rules.)

**§95.179 Individuals who may be station operators.**

(a) An individual GMRS system licensee may permit his/her immediate family members living in the same household to be station operators in his/her GMRS system. They may communicate messages about the licensee's personal activities and about the licensee's business activities. *Immediate family members* are the:

- (1) Licensee;
- (2) Licensee's spouse;
- (3) Licensee's children, grandchildren, stepchildren;
- (4) Licensee's parents, grandparents, stepparents;
- (5) Licensee's brothers, sisters;
- (6) Licensee's aunts, uncles, nieces, nephews; and
- (7) Licensee's in-laws.

(b) In a GMRS system licensed to a non-individual, eligible station operators are limited to the persons listed in paragraph (b)(1) of this section with the conditions listed in paragraph (b)(2) of this section as follows:

(1) Only the following persons may be permitted to operate under the authority of a GMRS system licensed to a non-individual:

If the GMRS system licensee is—	These persons may be station operators—
(i) A partnership .....	Licensee's partners and employees.
(ii) A corporation .....	Licensee's officers, directors, members and employees.
(iii) An association .....	Licensee's members and employees.
(iv) A governmental unit ...	Licensee's employees.

(2) These persons may only communicate messages about the licensee's business activities. Employees of the licensee may communicate messages

while acting within the scope of their employment, and only about the licensee's business activities.

(c) The licensee may permit a telephone answering service employee to be a station operator if:

- (1) That employee only communicates messages received for the licensee to the licensee;
- (2) The station equipment at the telephone answering point is not shared in any other GMRS system; and
- (3) The station at the telephone answering service point is not interconnected to the public switched telephone network.

(d) The station operator of a GMRS system licensed to an individual may be a station operator in any other GMRS system if he/she has permission from the licensee of the other GMRS system.

(e) The provisions of §95.33 regarding cooperative use do not apply to or govern the authority of a GMRS licensee to designate station operators in accordance with the provisions of this section.

(f) Except for emergency communications (see §95.143), only persons specified in paragraphs (a) through (d) may be GMRS station operators.

[48 FR 35237, Aug. 3, 1983, as amended at 53 FR 47717, Nov. 25, 1988; 53 FR 51625, Dec. 22, 1988]

**§95.181 Permissible communications.**

(a) A station operator for an individual who is licensed in the GMRS (other than an employee of that individual) may communicate two-way voice messages concerning the licensee's personal or business activities (see §95.179).

(b) [Reserved]

(c) A station operator for any entity other than an individual licensed in the GMRS may communicate two-way voice messages concerning the licensee's business activities (see §95.179). An employee for an entity other than an individual licensed in the GMRS may, as a station operator, communicate two-way voice messages while acting within the scope of his/her employment.

(d) A station operator for any GMRS licensee may communicate two-way voice messages concerning:

(1) Emergencies (see §95.143);  
 (2) Rendering assistance to a motorist; and

(3) Civil defense drills, if the responsible agency requests assistance.

(e) All messages must be in *plain language* (without codes or hidden meanings). They may be in a foreign language, except for call signs (see §95.119).

(f) A station operator may communicate tone messages for purposes of identification or transmitter control in a control link (see §95.127). (The FCC treats a control tone as voice in this case.)

(g) A station operator may communicate a selective calling tone or tone operated squelch only in conjunction with a voice communication. If the tone is *subaudible* (300 Hertz or less) it may be communicated during the entire voice message. If the tone is *audible* (more than 300 Hertz) it may be communicated for no more than 15 seconds at a time.

(h) A station operator may communicate a one-way voice page to a paging receiver. A selective calling tone or tone operated squelch may be used in conjunction with a voice page, as prescribed in paragraph (g) of this section. A station operator may not communicate a *tone-only page* (tones communicated in order to find, summon or notify someone).

(i) A station operator must not communicate:

(1) Messages for hire, whether the remuneration received is direct or indirect;

(2) Messages in connection with any activity which is against Federal, State or local law;

(3) False or deceptive messages;

(4) Coded messages or messages with hidden meanings ("10-codes" are permitted);

(5) Intentional interference;

(6) Music, whistling, sound effects or material to amuse or entertain;

(7) Sounds only to attract attention;

(8) Obscene, profane or indecent words, language or meaning;

(9) Advertisements or offers for the sale of goods or services;

(10) Advertisements for a political candidate or political campaign (mes-

sages about the campaign business may be communicated);

(11) International distress signals, such as the word "Mayday" (except when on a ship, aircraft or other vehicle in immediate danger to ask for help);

(12) Programs (live or delayed) intended for radio or television station broadcast (messages about news items or program preparation may be communicated);

(13) Messages which are both conveyed by a wireline control link and transmitted by a GMRS station (see §95.127);

(14) Messages (except emergency messages) to any station in the Amateur Radio Service, to any unauthorized station, or to any foreign station;

(15) Continuous or uninterrupted transmissions, except for communications involving the immediate safety of life or property; or

(16) Messages for public address systems.

(j) A station operator in a GMRS system licensed to a telephone answering service must not transmit any communications to customers of the telephone answering service.

[48 FR 35237, Aug. 3, 1983, as amended at 49 FR 4003, Feb. 1, 1984; 56 FR 13289, Apr. 1, 1991]

#### APPENDIX A TO SUBPART A—MAKING A CONTROL STATION POWER TEST

(a) A unit of the mobile station is brought to the control station *or* to a point within 402 meters (¼ mile) of the control station.

(b) The strength of the signal received at the terminals of the feedline to the antenna of the remotely controlled station produced by transmissions of the unit of your mobile station must be measured.

(c) The directional antenna of the control station must be aimed so that transmissions from it produce the greatest signal strength at the terminals of the feedline to the antenna of the remotely controlled station.

(d) The transmitter output power of the control station must be adjusted (see §95.135) so that the signal strength produced at the terminals of the feedline to the antenna of the remotely controlled station is no more than 6 decibels more than that produced by the unit of the mobile station. The maximum transmitter output power permitted any GMRS station must not be exceeded (see §95.135).

Federal Communications Commission

Pt. 95, Subpt. A, App. B

(e) A record must be made of each control station power test and kept as part of the GMRS system records.

[48 FR 35237, Aug. 3, 1983, as amended at 49 FR 4003, Feb. 1, 1984, 57 FR 40343, Sept. 3, 1992]

APPENDIX B TO SUBPART A—WHERE THE LARGE URBAN AREAS ARE LOCATED

City	North Latitude	West Longitude
	° ' "	° ' "
Akron, OH	41 05 00	81 30 44
Albany-Schenectady-Troy, NY	42 39 01	73 45 01
Albuquerque, NM	35 05 01	106 39 05
Allentown-Bethlehem-Easton, PA-NJ	40 36 11	75 28 06
Ann Arbor, MI	42 16 59	83 44 52
Atlanta, GA	33 45 10	84 23 37
Augusta, GA-SC	33 28 20	81 58 00
Austin, TX	30 16 09	97 44 37
Bakersfield, CA	35 22 31	119 01 16
Baltimore, MD	39 17 26	76 36 45
Baton Rouge, LA	30 26 58	91 11 00
Birmingham, AL	33 31 01	86 48 36
Boston, MA	42 21 24	71 03 25
Bridgeport, CT	41 10 49	73 11 22
Buffalo, NY	42 52 52	78 52 21
Canton, OH	40 47 50	81 22 37
Charleston, SC	32 46 35	79 55 53
Charlotte, NC	35 13 44	80 50 45
Chattanooga, TN-GA	35 02 41	85 18 32
Chicago, IL-Northwestern IN	41 52 28	87 38 22
Cincinnati, OH-KY	39 06 07	84 30 35
Cleveland, OH	41 29 51	81 41 50
Colorado Springs, CO	38 50 07	104 49 16
Columbia, SC	34 00 02	81 02 00
Columbus, GA-Ala	32 28 07	84 59 24
Columbus, OH	39 57 47	83 00 17
Corpus Christi, TX	27 47 51	97 23 45
Dallas-Fort Worth, TX	32 47 09	96 47 37
Davenport-Rock Island-Moline, IA-IL	41 31 00	90 35 00
Dayton, OH	39 45 32	84 11 43
Denver, CO	39 44 58	104 59 22
Des Moines, IA	41 35 14	93 37 00
Detroit, MI	42 19 48	83 02 57
El Paso, TX	31 45 36	106 29 11
Fayetteville, NC	35 03 00	78 53 00
Flint, MI	43 00 50	83 41 33
Fort Lauderdale-Hollywood, FL	26 07 00	80 09 00
Fort Wayne, IN	41 04 21	85 08 26
Fresno, CA	36 44 12	119 47 11
Grand Rapids, MI	42 58 03	85 40 13
Greenville, SC	34 50 50	82 24 01
Harrisburg, PA	40 15 43	76 52 59
Hartford, CT	41 46 12	72 40 49
Honolulu, HI	21 19 00	157 52 00
Houston, TX	29 45 26	95 21 37
Indianapolis, IN	39 46 07	86 09 46
Jackson, MS	32 17 56	90 11 06
Jacksonville, FL	30 19 44	81 39 42
Kansas City, MO-KS	39 04 56	94 35 20
Knoxville, TN	35 57 39	83 55 07
Lansing, MI	42 44 01	84 33 15
Las Vegas, NV	36 10 20	115 08 37
Lawrence-Haverhill, MA-NH	42 42 16	71 10 08
Little Rock-North Little Rock, AR	34 44 42	92 16 37
Lorain-Elyria, OH	41 28 00	82 11 00
Los Angeles-Long Beach, CA	34 03 15	118 14 28
Louisville, KY-IN	38 14 47	85 45 49
Madison, WI	43 04 23	89 22 55
Melbourne-Cocoa, FL	28 05 00	80 36 00
Memphis, TN-AR-MS	35 08 46	90 03 13

City	North Latitude	West Longitude
	° ' "	° ' "
Miami, FL	25 46 37	80 11 32
Milwaukee, WI	43 02 19	87 54 15
Minneapolis-St. Paul, MN	44 58 57	93 15 43
Mobile, AL	30 41 36	88 02 33
Nashville-Davidson, TN	36 09 33	86 46 55
New Haven, CT	41 18 25	72 55 30
New Orleans, LA	29 56 53	90 04 10
Newport News-Hampton, VA	36 59 30	76 26 00
New York, NY-Northeastern NJ	40 45 06	73 59 39
Norfolk-Portsmouth, VA	36 51 10	76 17 21
Ogden, UT	41 13 31	111 58 21
Oklahoma City, OK	35 28 26	97 31 04
Omaha, NE-IA	41 15 42	95 56 14
Orlando, FL	28 32 42	81 22 38
Oxnard-Ventura-Thousand Oaks, CA	34 12 00	119 11 00
Pensacola, FL	30 24 51	87 12 56
Peoria, IL	40 41 42	89 35 33
Philadelphia, PA-NJ	39 56 58	75 09 21
Phoenix, AZ	33 27 12	112 04 28
Pittsburgh, PA	40 26 19	80 00 00
Portland, OR-WA	45 31 06	122 40 35
Providence-Pawtucket-Warwick, RI-MA	41 49 32	71 24 41
Raleigh, NC	35 46 38	78 38 21
Richmond, VA	37 32 15	77 26 09
Rochester, NY	43 09 41	77 36 21
Rockford, IL	42 16 07	89 05 48
Sacramento, CA	38 34 57	121 29 41
St. Louis, MO-IL	38 37 45	90 12 22
St. Petersburg, FL	27 46 18	82 38 19
Salt Lake City, UT	40 45 23	111 53 26
San Antonio, TX	29 25 37	98 29 06
San Bernardino-Riverside, CA	34 06 30	117 17 28
San Diego, CA	32 42 53	117 09 21
San Francisco-Oakland, CA	37 46 39	122 24 40
San Jose, CA	37 20 16	121 53 24
Sarasota-Bradenton, FL	27 20 05	82 32 20
Scranton-Wilkes-Barre, PA	41 24 32	75 39 46
Seattle-Everett, WA	47 36 32	122 20 12
Shreveport, LA	32 30 46	93 44 58
South Bend, IN-MI	41 40 33	86 15 01
Spokane, WA	47 39 32	117 25 33
Springfield-Chicopee-Holyoke, MA-CT	42 06 21	72 35 32
Syracuse, NY	43 03 04	76 09 14
Tacoma, WA	47 14 59	122 26 15
Tampa, FL	27 56 58	82 27 25
Toledo, OH-MI	41 39 14	83 32 39
Trenton, NJ-PA	40 13 30	74 45 00
Tucson, AZ	32 13 15	110 58 08
Tulsa, OK	36 09 12	95 59 34
Washington, DC-MD-VA	38 53 51	77 00 33
West Palm Beach, FL	26 42 36	80 03 07
Wichita, KS	37 41 30	97 20 16
Wilmington, DE-NJ-MD	39 44 46	75 32 51
Worcester, MA	42 15 37	71 48 17
Youngstown-Warren, OH	41 05 57	80 39 02
San Juan, PR	18 28 00	66 07 00

NOTE 1: This appendix lists the urbanized areas of 200,000 or more people as shown in the Bureau of Census News Release of July 27, 1981: "Provisional Population of Urbanized Areas, 1980." The geographical coordinates given are from the Department of Commerce publication of 1947: "Air-Line Distances Between Cities in the United States" and from data supplied by the National Geodetic Survey. The coordinates are determined by using the first city mentioned in the urbanized area as the center of the urbanized area.

### Subpart B—Family Radio Service (FRS)

SOURCE: 61 FR 28768, June 6, 1996, unless otherwise noted.

#### GENERAL PROVISIONS

#### § 95.191 (FRS Rule 1) Eligibility and responsibility.

(a) Unless you are a representative of a foreign government, you are authorized by this rule to operate an FCC certified FRS unit in accordance with the rules in this subpart. No license will be issued.

(b) You are responsible for all communications that you make with the FRS unit. You must share each channel with other users. No channel is available for the private or exclusive use of any user.

#### § 95.192 (FRS Rule 2) Authorized locations.

(a) Provided that you comply with these rules, you are authorized to operate an FRS unit:

(1) Within or over any area of the world where radio services are regulated by the FCC (this area includes the fifty United States and the District of Columbia, the Commonwealth of Puerto Rico, the United States Virgin Islands (50 islets and cays), American Samoa (seven islands), the Commonwealth of Northern Marianna Islands, and Guam Island);

(2) Within or over any other area of the world, except within or over the territorial limits of areas where radio services are regulated by an agency of the United States other than the FCC or any foreign government (you are subject to its rules);

(3) Aboard any vessel or aircraft registered in the United States, with the permission of the captain, that is within or over any area of the world where radio services are regulated by the FCC or upon or over international waters;

(4) or; Aboard any unregistered vessel or aircraft owned or operated by a United States citizen or company that is within or over any area of the world where radio services are regulated by the FCC or upon or over international waters.

(5) You must operate the FRS unit only according to any applicable treaty to which the United States is a party. The FCC will make public notice of any such conditions.

(b) Your use of an FRS unit must not cause harmful interference to a FCC monitoring facility. Doing so could result in imposition of restrictions upon the operation of the FRS unit within 0.8 km (0.5 mile) of the facility by its Engineer-in-Charge. (Geographical coordinates of the facilities that require protection are listed in § 0.121(c) of this chapter.)

(c) The FCC may impose additional restrictions on a FRS station if the station is located at a point within the National Radio Quiet Zone (an area within the States of Maryland, Virginia and West Virginia). The Zone is the area bounded by:

- (1) 39° 15' N. on the North;
- (2) 78° 30' W. on the East;
- (3) 37° 30' N. on the South; and
- (4) 80° 30' W. on the West.

#### § 95.193 (FRS Rule 3) Types of communications.

(a) You may use an FRS unit to conduct two-way voice communications with another person. You may use the FRS unit to transmit one-way communications only to establish communications with another person, send an emergency message, provide traveler assistance, make a voice page, or to conduct a brief test.

(b) The FRS unit may transmit tones to make contact or to continue communications with a particular FRS unit. If the tone is audible (more than 300 Hertz), it must last no longer than 15 seconds at one time. If the tone is subaudible (300 Hertz or less), it may be transmitted continuously only while you are talking.

(c) You must not use an FRS unit in connection with any activity which is against federal, state or local law.

(d) You must, at all times and on all channels, give priority to emergency communication messages concerning the immediate safety of life or the immediate protection of property.

(e) No FRS unit may be interconnected to the public switched network.

**§95.194 (FRS Rule 4) FRS units.**

(a) You may only use an FCC certified FRS unit. (You can identify an FCC certified FRS unit by the label placed on it by the manufacturer.)

(b) You must not make, or have made, any internal modification to an FRS unit. Any internal modification cancels the FCC certification and voids your authority to operate the unit in the FRS.

(c) You may not attach any antenna, power amplifier, or other apparatus to an FRS unit that has not been FCC certified as part of that FRS unit. There are no exceptions to this rule and attaching any such apparatus to a FRS unit cancels the FCC certification and voids everyone's authority to operate the unit in the FRS.

### Subpart C—Radio Control (R/C) Radio Service

SOURCE: 48 FR 24890, June 3, 1983, unless otherwise noted.

#### GENERAL PROVISIONS

**§95.201 (R/C Rule 1) What is the Radio Control (R/C) Radio Service?**

The R/C Service is a private, one-way, short distance non-voice communications service for the operation of devices at remote locations.

**§95.202 (R/C Rule 2) How do I use these rules?**

(a) You must comply with rules (see R/C Rule 18, §95.218, for the penalties for violations) when you operate a station in the R/C service from:

(1) Within or over the territorial limits of places where radio services are regulated by the FCC (see R/C Rule 5, §95.205);

(2) Aboard any vessel or aircraft registered in the United States; or

(3) Aboard any unregistered vessel or aircraft owned or operated by a United States citizen or company.

(b) Your R/C station must comply with technical rules found in subpart E of part 95.

(c) Where the rules use the word "you", "you" means a person operating an R/C station.

(d) Where the rules use the word "person," the rules are concerned with

an individual, a corporation, a partnership, an association, a joint stock company, a trust, a state, territorial or local government unit, or other legal entity.

(e) Where the rules use the term "FCC," that means the Federal Communications Commission.

(f) Where the rules use the term "R/C station," that means a radio station transmitting in the R/C Radio Service.

**§95.203 (R/C Rule 3) Am I eligible to operate an R/C station?**

You are authorized to operate an R/C station unless:

(a) You are a foreign government, a representative of a foreign government, or a federal government agency; or

(b) The FCC has issued a cease and desist order to you, and the order is still in effect.

**§95.204 (R/C Rule 4) Do I need a license?**

You do not need an individual license to operate an R/C station. You are authorized by this rule to operate your R/C station in accordance with the rules in this subpart.

**§95.205 (R/C Rule 5) Where may I operate my R/C station?**

You are authorized to operate your R/C station from:

(a) Within or over any area of the world where radio services are regulated by the FCC. Those areas are within the territorial limits of:

- (1) The fifty United States
- (2) The District of Columbia

#### *Caribbean Insular areas*

- (3) Commonwealth of Puerto Rico
- (4) Navassa Island
- (5) United States Virgin Islands (50 islets and cays)

#### *Pacific Insular areas*

- (6) American Samoa (seven islands)
- (7) Baker Island
- (8) Commonwealth of Northern Mariana Islands
- (9) Guam Island
- (10) Howland Island
- (11) Jarvis Island
- (12) Johnston Island (Islets East, Johnston, North and Sand)

§ 95.206

47 CFR Ch. I (10–1–96 Edition)

- (13) Kingman Reef
- (14) Midway Island (Islets Eastern and Sand)
- (15) Palmyra Island (more than 50 islets)
- (16) Wake Island (Islets Peale, Wake and Wilkes)

(b) Any other area of the world, except within the territorial limits of areas where radio services are regulated by—

(1) An agency of the United States other than the FCC. (You are subject to its rules.)

(2) Any foreign government. (You are subject to its rules.)

(c) An aircraft or ship, with the permission of the captain, within or over any area of the world where radio services are regulated by the FCC or upon or over international waters. You must operate your R/C station according to any applicable treaty to which the United States is a party.

**§95.206 (R/C Rule 6) Are there any special restrictions on the location of my R/C station?**

(a) If your R/C station is located on premises controlled by the Department of Defense, you may be required to comply with additional regulations imposed by the commanding officer of the installation.

(b) If your R/C station will be constructed on an environmental sensitive site, or will be operated in such a manner as to raise environmental problems, under §1.1307 of this chapter, you must provide an environmental assessment, as set forth in §1.1311 of this chapter, and undergo environmental review §1.1312 of this chapter, before commencement of construction.

[48 FR 24890, June 3, 1983, as amended at 55 FR 20398, May 16, 1990]

HOW TO OPERATE AN R/C STATION

**§95.207 (R/C Rule 7) On what channels may I operate?**

(a) Your R/C station may transmit only on the following channels (frequencies):

(1) The following channels may be used to operate any kind of device (any object or apparatus, except an R/C transmitter), including a model air-

craft device (any small imitation of an aircraft) or a model surface craft device (any small imitation of a boat, car or vehicle for carrying people or objects, except aircraft): 26.995, 27.045, 27.095, 27.145, 27.195 and 27.255 MHz.

(2) The following channels may only be used to operate a model aircraft device:

	MHz
72.01	72.51
72.03	72.53
72.05	72.55
72.07	72.57
72.09	72.59
72.11	72.61
72.13	72.63
72.15	72.65
72.17	72.67
72.19	72.69
72.21	72.71
72.23	72.73
72.25	72.75
72.27	72.77
72.29	72.79
72.31	72.81
72.33	72.83
72.35	72.85
72.37	72.87
72.39	72.89
72.41	72.91
72.43	72.93
72.45	72.95
72.47	72.97
72.49	72.99

(3) The following channels may only be used to operate a model surface craft devices:

	MHz
75.41	75.71
75.43	75.73
75.45	75.75
75.47	75.77
75.49	75.79
75.51	75.81
75.53	75.83
75.55	75.85
75.57	75.87
75.59	75.89
75.61	75.91
75.63	75.93
75.65	75.95
75.67	75.97
75.69	75.99

(b) You must share the channels with other R/C stations. You must cooperate in the selection and use of the channels. You must share the Channel 27.255



MHz with stations in other radio services. There is no protection from interference on any of these channels.

(c) Your R/C station may not transmit simultaneously on more than one channel in the 72-76 MHz band when your operation would cause harmful interference to the operation of other R/C stations.

(d) Your R/C station must stop transmitting if it interferes with:

(1) Authorized radio operations in the 72-76 MHz band; or

(2) Television reception on TV Channels 4 or 5.

(e) [Reserved]

(f) Stations in the 26-27 MHz range are not afforded any protection from interference caused by the operation of industrial, scientific or medical devices. Such stations also operate on a shared basis with other stations in the Personal Radio Services.

(g) Stations in the 72-76 MHz range are subject to the condition that interference will not be caused to the remote control of industrial equipment operating on the same or adjacent frequencies or to the reception of television transmissions on Channels 4 and 5. These frequencies are not afforded any protection from interference due to the operation of fixed and mobile stations in other services assigned to the same or adjacent frequencies.

[48 FR 24890, June 3, 1983. Redesignated at 49 FR 6098, Feb. 17, 1984, and amended at 50 FR 37857, Sept. 18, 1985; 52 FR 16263, May 4, 1987; 57 FR 40343, Sept. 3, 1992]

#### **§95.208 (R/C Rule 8) How high may I put my antenna?**

(a) *Antenna* means the radiating system (for transmitting, receiving or both) and the structure holding it up (tower, pole or mast). It also means everything else attached to the radiating system and the structure.

(b) If your antenna is mounted on a hand-held portable unit, none of the following limitations apply.

(c) If your antenna is installed at a fixed location, it (whether receiving, transmitting or both) must comply with either one of the following:

(1) The highest point must not be more than 6.10 meters (20 feet) higher than the highest point of the building or tree on which it is mounted; or

(2) The highest point must not be more than 18.3 meters (60 feet) above the ground.

(d) If your R/C station is located near an airport, and if your antenna structure is more than 6.1 meters (20 feet) high, you may have to obey additional restrictions. The highest point of your antenna must not exceed one meter above the airport elevation for every hundred meters of distance from the nearest point of the nearest airport runway. Differences in ground elevation between your antenna and the airport runway may complicate this formula. If your R/C station is near an airport, you may contact the nearest FCC field office for a worksheet to help you figure the maximum allowable height of your antenna. Consult part 17 of the FCC's Rules for more information.

---

WARNING: Installation and removal of R/C station antennas near powerlines is dangerous. For your safety, follow the installation directions included with your antenna.

---

[48 FR 24890, June 3, 1983, as amended at 48 FR 41416, Sept. 15, 1983]

#### **§95.209 (R/C Rule 9) What equipment may I use at my R/C station?**

(a) Your R/C station may transmit only with:

(1) An FCC type accepted (or type approved) R/C transmitter (Type accepted means the FCC has determined that certain radio equipment is capable of meeting recommended standards for operation); or

(2) A non-type accepted R/C transmitter on Channels 26.995-27.255 MHz if it complies with the technical standards (see part 95, subpart E).

(3) Use of a transmitter outside of the band 26.995-27.255 MHz which is not type accepted (or type approved) voids your authority to operate the station. Use of a transmitter in the band 26.995-27.255 MHz which does not comply with the technical standards voids your authority to operate the station.

(b) You may examine a list of type accepted transmitters at any FCC field office.

(c) Your R/C station may transmit with a transmitter assembled from a kit.

§ 95.210

(d) You must not make, or have made, any internal modification to a type-accepted transmitter. (See R/C Rule 22.) Any internal modification to a type-accepted transmitter cancels the type-acceptance, and use of such a transmitter voids your authority to operate the station.

**§ 95.210 (R/C Rule 10) How much power may I use?**

(a) Your R/C station transmitter power output must not exceed the following value under any conditions:

Channel	Transmitter power (carrier power) (watts)
27.255 MHz .....	25
26.995-27.195 MHz .....	4
72-76 MHz .....	0.75

(b) Use of a transmitter which has power output in excess of that author-

ized voids your authority to operate the station.

**§ 95.211 (R/C Rule 11) What communications may be transmitted?**

(a) You may only use your R/C station to transmit one-way communications. (One-way communications are transmissions which are not intended to establish communications with another station.)

(b) You may only use your R/C station for the following purposes:

(1) The operator turns on and/or off a device at a remote location (Refer to Diagram 1); or

(2) A sensor at a remote location turns on and/off an indicating device for the operator. (Refer to Diagram 2). Only Channels 26.995 to 27.255 MHz (see R/C Rule 7, § 95.207(a)(1)) may be used for this purpose. (A remote location means a place distant from the operator.)

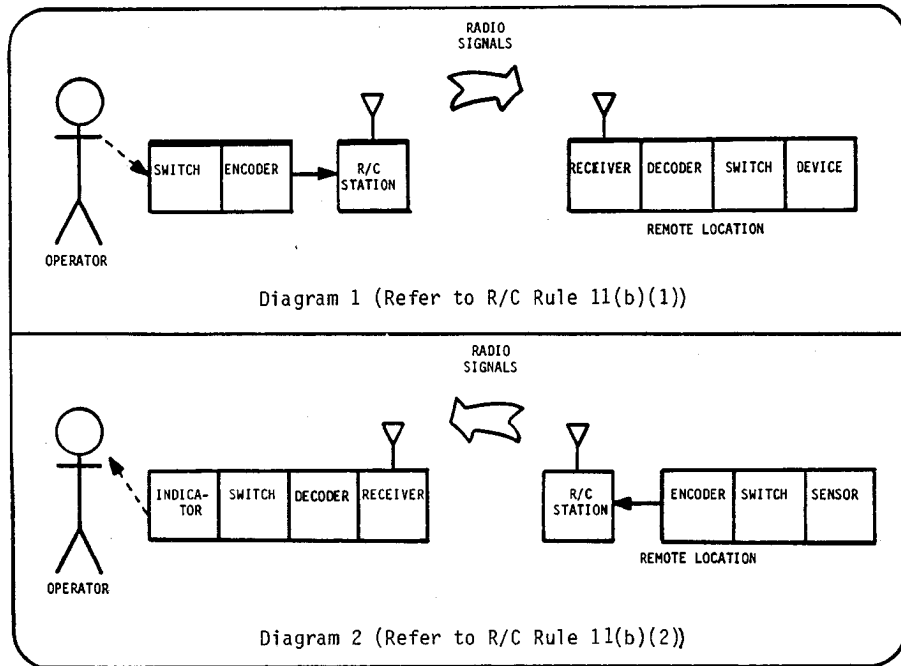

(c) Your R/C station may transmit any appropriate non-voice emission.

[48 FR 24890, June 3, 1983, as amended at 50 FR 37857, Sept. 18, 1985; 57 FR 40343, Sept. 3, 1992]

**§95.212 (R/C Rule 12) What communications are prohibited?**

You must not use an R/C station—

(a) In connection with any activity which is against federal, state or local law;

(b) To transmit any message other than for operation of devices at remote locations (no voice, telegraphy, etc.);

(c) To intentionally interfere with another station's transmissions;

(d) To operate another R/C transmitter by remote control (See R/C Rule 17, §95.217); or

(e) To transmit two-way communications.

(f) To transmit data. Tone or other signal encoding, however, is not considered to be data when only used either for the purpose of identifying the specific device among multiple devices that the operator intends to turn on/off, or the specific sensor among multiple sensors intended to turn on/off indicating device for the operator.

[48 FR 24890, June 3, 1983, as amended at 54 FR 8336, Feb. 28, 1989; 54 FR 20476, May 11, 1989]

**§95.213 (R/C Rule 13) May I be paid to use my R/C station?**

(a) You may not accept direct or indirect payment for transmitting with an R/C station.

(b) You may use an R/C station to help you provide a service, and be paid for that service, as long as you are paid only for the service and not for the actual use of the R/C station.

**§95.214 (R/C Rule 14) Who is responsible for R/C communications I make?**

You are responsible for all communications which are made by you from an R/C station.

**§95.215 (R/C Rule 15) Do I have to limit the length of my communications?**

(a) You must limit your R/C communications to the minimum practical time.

(b) The only time your R/C communications may be a continuous signal for more than 3 minutes is when operation of the device requires at least one or more changes during each minute of the communications.

(c) Your R/C station may transmit a continuous signal without modulation only if:

(1) You are using it to operate a model aircraft device; and

(2) The presence or absence of the signal operates the device.

(d) If you show that you need a continuous signal to insure the immediate safety of life or property, the FCC may make an exception to the limitations in this rule.

**§95.216 (R/C Rule 16) Do I identify my R/C communications?**

You need not identify your R/C communications.

**§95.217 (R/C Rule 17) May I operate my R/C station transmitter by remote control?**

(a) You may not operate an R/C transmitter by radio remote control. (See R/C Rule 12, §95.212.)

(b) You may operate an R/C transmitter by wireline remote control if you obtain specific approval in writing from the FCC. To obtain FCC approval, you must show why you need to operate your station by wireline remote control. Send your justification to FCC, Gettysburg, Pa. 17325. If you receive FCC approval, you must keep the approval as part of your station records. (See R/C Rule 24, §95.224.)

(c) Remote control means operation of an R/C transmitter from any place other than the location of the R/C transmitter. Direct mechanical control or direct electrical control by wire from some point on the same premises, craft or vehicles as the R/C transmitter is not considered remote control.

**OTHER THINGS YOU NEED TO KNOW**

**§95.218 (R/C Rule 18) What are the penalties for violating these rules?**

(a) If the FCC finds that you have willfully or repeatedly violated the Communications Act or the FCC Rules, you may have to pay as much as \$10,000 for each violation, up to a total of

\$75,000. (See Section 503(b) of the Communications Act.)

(b) If the FCC finds that you have violated any section of the Communications Act or the FCC Rules, you may be ordered to stop whatever action caused the violation. (See section 312(b) of the Communications Act.)

(c) If a federal court finds that you have willfully and knowingly violated any FCC Rule, you may be fined up to \$500 for each day you committed the violation. (See section 502 of the Communications Act.)

(d) If a Federal court finds that you have willfully and knowingly violated any provision of the Communications Act, you may be fined up to \$10,000, or you may be imprisoned for one year, or both. (See section 501 of the Communications Act.)

[48 FR 24890, June 3, 1983, as amended at 57 FR 40343, Sept. 3, 1992]

**§ 95.219 (R/C Rule 19) How do I answer correspondence from the FCC?**

(a) If it appears to the FCC that you have violated the Communications Act or FCC rules, the FCC may send you a discrepancy notice.

(b) Within the time period stated in the notice, you must answer with:

(1) A complete written statement about the apparent discrepancy;

(2) A complete written statement about any action you have taken to correct the apparent violation and to prevent it from happening again; and

(3) The name of the person operating at the time of the apparent violation.

(c) If the FCC send you a letter asking you questions about your R/C radio station or its operation, you must answer each of the questions with a complete written statement within the time period stated in the letter.

(d) You must not shorten your answer by references to other communications or notices.

(e) You must send your answer to the FCC office which sent you the notice.

(f) You must keep a copy of your answer in your station records (see R/C Rule 24, §95.224).

**§ 95.220 (R/C Rules 20) What must I do if the FCC tells me that my R/C station is causing interference?**

(a) If the FCC tells you that your R/C station is causing interference for technical reasons, you must follow all instructions in the official FCC notice. (This notice may require you to have technical adjustments made to your equipment.)

(b) You must comply with any restricted hours of R/C station operation which may be included in the official FCC notice.

**§ 95.221 (R/C Rule 21) How do I have my R/C transmitter serviced?**

(a) You may adjust an antenna to your R/C transmitter and you may make radio checks. (A radio check means a one-way transmission for a short time in order to test the transmitter.)

(b) You are responsible for the proper operation of the station at all times and are expected to provide for observations, servicing and maintenance as often as may be necessary to ensure proper operation. Each internal repair and each internal adjustment to an FCC type accepted R/C transmitter (see R/C Rule 9) must be made in accord with the Technical Regulations (see subpart E). The internal repairs or internal adjustments should be performed by or under the immediate supervision and responsibility of a person certified as technically qualified to perform transmitter maintenance and repair duties in the private land mobile services and fixed services by an organization or committee representative of users in those services.

(c) Except as provided in paragraph (d) of this section, each internal repair and each internal adjustment of an R/C transmitter in which signals are transmitted must be made using a non-radiating ("dummy") antenna.

(d) Brief test signals (signals not longer than one minute during any five minute period) using a radiating antenna may be transmitted in order to:

(1) Adjust a transmitter to an antenna;

(2) Detect or measure radiation of energy other than the intended signal; or

(3) Tune a receiver to your R/C transmitter.

(Secs. 4(i) and 303(r), Communications Act of 1934, as amended, 47 U.S.C. 154(i) and 303(r), and sec. 553 of the Administrative Procedures Act, 5 U.S.C. 553)

[48 FR 24890, June 3, 1983, as amended at 49 FR 20673, May 16, 1984]

**§95.222 (R/C Rule 22) May I make any changes to my R/C station transmitter?**

(a) You must not make or have anyone else make an internal modification to your R/C transmitter.

(b) Internal modification does not include:

(1) Repair or servicing of an R/C station transmitter (see R/C Rule 21, §95.221); or

(2) Changing plug-in modules which were type-accepted as part of your R/C transmitter.

(c) You must not operate an R/C transmitter which has been modified by anyone in any way, including modification to operate on unauthorized frequencies or with illegal power. (See R/C Rules 9 and 10, §§95.209 and 95.210.)

**§95.223 (R/C Rule 23) Do I have to make my R/C station available for inspection?**

(a) If an authorized FCC representative requests to inspect your R/C station, you must make your R/C station and records available for inspection.

(b) An R/C station includes all of the radio equipment you use.

**§95.224 (R/C Rule 24) What are my station records?**

Your station records include the following documents, as applicable:

(a) A copy of each response to an FCC violation notice or an FCC letter. (See R/C Rule 19, §95.219.)

(b) Each written permission received from the FCC. (See R/C Rule 17.)

**§95.225 (R/C Rule 25) How do I contact the FCC?**

(a) Write to your nearest FCC Field Office if you:

(1) Want to report an interference complaint; or

(2) Want to know if the FCC has type-accepted a transmitter for R/C.

(b) Write to the FCC, Wireless Telecommunications Bureau, Private Wireless Division, Washington, DC 20554, if you have questions about the R/C Rules.

[48 FR 24890, June 3, 1983, as amended at 48 FR 41416, Sept. 15, 1983; 60 FR 50123, Sept. 28, 1995]

**Subpart D—Citizens Band (CB) Radio Service**

SOURCE: 48 FR 24894, June 3, 1983, unless otherwise noted.

GENERAL PROVISIONS

**§95.401 (CB Rule 1) What are the Citizens Band Radio Services?**

The Citizens Band Radio Services are:

(a) The Citizens Band (CB) Radio Service—a private, two-way, short-distance voice communications service for personal or business activities of the general public. The CB Radio Service may also be used for voice paging.

(b) The Family Radio Service (FRS)—a private, two-way, very short-distance voice communications service for facilitating family and group activities. The rules for this service are contained in subpart B of this part.

(c) The Low Power Radio Service (LPRS)—a private, short-distance communication service providing auditory assistance to persons with disabilities, persons who require language translation, and persons in educational settings, health care assistance to the ill, law enforcement tracking services in cooperation with law enforcement, and point-to-point network control communications for Automated Marine Telecommunications System (AMTS) coast stations licensed under part 80 of this chapter. The rules for this service are listed under subpart G of this part. Two-way voice communications are prohibited.

[61 FR 28769, June 6, 1996, as amended at 61 FR 46566, Sept. 4, 1996]

EFFECTIVE DATE NOTE: At 61 FR 46566, Sept. 4, 1996, §95.401 was amended by adding paragraph (c), effective Oct. 4, 1996.

**§ 95.402 (CB Rule 2) How do I use these rules?**

(a) You must comply with these rules (See CB Rule 21 §95.421, for the penalties for violations) when you operate a station in the CB Service from:

(1) Within or over the territorial limits of places where radio services are regulated by the FCC (see CB Rule 5, §95.405);

(2) Aboard any vessel or aircraft registered in the United States; or

(3) Aboard any unregistered vessel or aircraft owned or operated by a United States citizen or company.

(b) Your CB station must comply with technical rules found in subpart E of part 95.

(c) Where the rules use the word “you”, “you” means a person operating a CB station.

(d) Where the rules use the word “person,” the rules are concerned with an individual, a corporation, a partnership, an association, a joint stock company, a trust, a state, territorial or local government unit, or other legal entity.

(e) Where the rules use the term “FCC”, that means the Federal Communications Commission.

(f) Where the rules use the term “CB station”, that means a radio station transmitting in the CB Radio Service.

**§ 95.403 (CB Rule 3) Am I eligible to operate a CB station?**

You are authorized to operate a CB station unless:

(a) You are a foreign government, a representative of a foreign government, or a federal government agency; or

(b) The FCC has issued a cease and desist order to you, and the order is still in effect.

**§ 95.404 (CB Rule 4) Do I need a license?**

You do not need an individual license to operate a CB station. You are authorized by this rule to operate your CB station in accordance with the rules in this subpart.

**§ 95.405 (CB Rule 5) Where may I operate my CB station?**

You are authorized to operate your CB station from:

(a) Within or over any area of the world where radio services are regulated by the FCC. Those areas are within the territorial limits of:

- (1) The fifty United States.
- (2) The District of Columbia.

*Caribbean Insular areas*

- (3) Commonwealth of Puerto Rico.
- (4) Navassa Island.
- (5) United States Virgin Islands (50 islets and cays).

*Pacific Insular areas*

- (6) American Samoa (seven islands).
- (7) Baker Island.
- (8) Commonwealth of Northern Mariana Islands.
- (9) Guam Island.
- (10) Howland Island.
- (11) Jarvis Island.
- (12) Johnston Island (Islets East, Johnston, North and Sand).
- (13) Kingman Reef.
- (14) Midway Island (Islets Eastern and Sand).
- (15) Palmyra Island (more than 50 islets).
- (16) Wake Island (Islets Peale, Wake and Wilkes).

(b) Any other area of the world, except within the territorial limits of areas where radio services are regulated by—

(1) An agency of the United States other than the FCC. (You are subject to its rules.)

(2) Any foreign government. (You are subject to its rules.)

(c) An aircraft or ship, with the permission of the captain, within or over any area of the world where radio services are regulated by the FCC or upon or over international waters. You must operate your CB station according to any applicable treaty to which the United States is a party.

**§ 95.406 (CB Rule 6) Are there any special restrictions on the location of my CB station?**

(a) If your CB station is located on premises controlled by the Department of Defense you may be required to comply with additional regulations imposed by the commanding officer of the installation.

Federal Communications Commission

§ 95.408

(b) If your C/B station will be constructed on an environmentally sensitive site, or will be operated in such a manner as to raise environmental problems, under §1.1307 of this chapter, you must provide an environmental assessment, as set forth in §1.1311 of this chapter, and undergo the environmental review, §1.1312 of this chapter, before commencement of construction.

[48 FR 24894, June 3, 1983, as amended at 55 FR 20398, May 16, 1990]

HOW TO OPERATE A CB STATION

**§95.407 (CB Rule 7) On what channels may I operate?**

(a) Your CB station may transmit only on the following channels (frequencies):

Channel	Frequency (megahertz—MHz)
1	26.965
2	26.975
3	26.985
4	27.005
5	27.015
6	27.025
7	27.035
8	27.055
9	<sup>1</sup> 27.065
10	27.075
11	27.085
12	27.105
13	27.115
14	27.125
15	27.135
16	27.155
17	27.165
18	27.175
19	27.185
20	27.205
21	27.215
22	27.225
23	27.255
24	27.235
25	27.245
26	27.265
27	27.275
28	27.285
29	27.295
30	27.305
31	27.315
32	27.325
33	27.335
34	27.345
35	27.355
36	27.365
37	27.375
38	27.385
39	27.395
40	27.405

<sup>1</sup> See paragraph (b) of this section.

(b) Channel 9 may be used only for emergency communications or for traveler assistance.

(c) You must, at all times and on all channels, give priority to emergency communication messages concerning the immediate safety of life or the immediate protection of property.

(d) You may use any channel for emergency communications or for traveler assistance.

(e) You must share each channel with other users.

(f) The FCC will not assign any channel for the private or exclusive use of any particular CB station or group of stations.

(g) The FCC will not assign any channel for the private or exclusive use of CB stations transmitting single side-band or AM.

**§95.408 (CB Rule 8) How high may I put my antenna?**

(a) *Antenna* means the radiating system (for transmitting, receiving or both) and the structure holding it up (tower, pole or mast). It also means everything else attached to the radiating system and the structure.

(b) If your antenna is mounted on a hand-held portable unit, none of the following limitations apply.

(c) If your antenna is installed at a fixed location, it (whether receiving, transmitting or both) must comply with either one of the following:

(1) The highest point must not be more than 6.10 meters (20 feet) higher than the highest point of the building or tree on which it is mounted; or

(2) The highest point must not be more than 18.3 meters (60 feet) above the ground.

(d) If your CB station is located near an airport, and if you antenna structure is more than 6.1 meters (20 feet) high, you may have to obey additional restrictions. The highest point of your antenna must not exceed one meter above the airport elevation for every hundred meters of distance from the nearest point of the nearest airport runway. Differences in ground elevation between your antenna and the airport runway may complicate this formula. If your CB station is near an airport, you may contact the nearest FCC field office for a worksheet to help

you figure the maximum allowable height of your antenna. Consult part 17 of the FCC's Rules for more information.

---

WARNING: Installation and removal of CB station antennas near powerlines is dangerous. For your safety, follow the installation directions included with your antenna.

---

[48 FR 24894, June 3, 1983, as amended at 48 FR 41416, Sept. 15, 1983]

**§95.409 (CB Rule 9) What equipment may I use at my CB station?**

(a) You must use an FCC type-accepted CB transmitter at your CB station. You can identify an FCC type-accepted transmitter by the type-acceptance label placed on it by the manufacturer. You may examine a list of type-accepted equipment at any FCC Field Office or at FCC Headquarters. Use of a transmitter which is not FCC type-accepted voids your authority to operate the station.

(b) You must not make, or have made, any internal modification to a type-accepted CB transmitter. (See CB Rule 25, §95.425). Any internal modification to a type-accepted CB transmitter cancels the type-acceptance, and use of such a transmitter voids your authority to operate the station.

**§95.410 (CB Rule 10) How much power may I use?**

(a) Your CB station transmitter power output must not exceed the following values under any conditions:

AM (A3)—4 watts (carrier power) SSB—12 watts (peak envelope power)

(b) If you need more information about the power rule, see the technical rules in subpart E of part 95.

(c) Use of a transmitter which has carrier or peak envelope power in excess of that authorized voids your authority to operate the station.

**§95.411 (CB Rule 11) May I use power amplifiers?**

(a) You may not attach the following items (power amplifiers) to your type-accepted CB transmitter in any way:

(1) External radio frequency (RF) power amplifiers (sometimes called linears or linear amplifiers); or

(2) Any other devices which, when used with a radio transmitter as a signal source, are capable of amplifying the signal.

(b) There are no exceptions to this rule and use of a power amplifier voids your authority to operate the station.

(c) The FCC will presume you have used a linear or other external RF power amplifier if—

(1) It is in your possession or on your premises; and

(2) There is other evidence that you have operated your CB station with more power than allowed by CB Rule 10, §95.410.

(d) Paragraph (c) of this section does not apply if you hold a license in another radio service which allows you to operate an external RF power amplifier.

**§95.412 (CB Rule 12) What communications may be transmitted?**

(a) You may use your CB station to transmit two-way plain language communications. Two-way plain language communications are communications without codes or coded messages. Operating signals such as "ten codes" are not considered codes or coded messages. You may transmit two-way plain language communications only to other CB stations, to units of your own CB station or to authorized government stations on CB frequencies about—

(1) Your personal or business activities or those of members of your immediate family living in your household;

(2) Emergencies (see CB Rule 18, §95.418);

(3) Traveler assistance (see CB Rule 18, §95.418); or

(4) Civil defense activities in connection with official tests or drills conducted by, or actual emergencies announced by, the civil defense agency with authority over the area in which your station is located.

(b) You may use your CB station to transmit a tone signal only when the signal is used to make contact or to continue communications. (Examples of circuits using these signals are tone operated squelch and selective calling circuits.) If the signal is an audible tone, it must last no longer than 15 seconds at one time. If the signal is a



subaudible tone, it may be transmitted continuously only as long as you are talking.

(c) You may use your CB station to transmit one-way communications (messages which are not intended to establish communications between two or more particular CB stations) only for emergency communications, traveler assistance, brief tests (radio checks) or voice paging.

**§95.413 (CB Rule 13) What communications are prohibited?**

- (a) You must not use a CB station—
- (1) In connection with any activity which is against federal, state or local law;
  - (2) To transmit obscenity, indecent or profane words, language or meaning;
  - (3) To interfere intentionally with the communications of another CB station;
  - (4) To transmit one-way communications, except for emergency communications, traveler assistance, brief tests (radio checks), or voice paging;
  - (5) To advertise or solicit the sale of any goods or services;
  - (6) To transmit music, whistling, sound effects or any material to amuse or entertain;
  - (7) To transmit any sound effect solely to attract attention;
  - (8) To transmit the word "MAYDAY" or any other international distress signal, except when your station is located in a ship, aircraft or other vehicle which is threatened by grave and imminent danger and you are requesting immediate assistance;
  - (9) To communicate with, or attempt to communicate with, any CB station more than 250 kilometers (155.3 miles) away;
  - (10) To advertise a political candidate or political campaign; (you may use your CB radio for the business or organizational aspects of a campaign, if you follow all other applicable rules);
  - (11) To communicate with stations in other countries, except General Radio Service stations in Canada; or
  - (12) To transmit a false or deceptive communication.
- (b) You must not use a CB station to transmit communications for live or delayed rebroadcast on a radio or tele-

vision broadcast station. You may use your CB station to gather news items or to prepare programs.

**§95.414 (CB Rule 14) May I be paid to use my CB station?**

- (a) You may not accept direct or indirect payment for transmitting with a CB station.
- (b) You may use a CB station to help you provide a service, and be paid for that service, as long as you are paid only for the service and not for the actual use of the CB station.

**§95.415 (CB Rule 15) Who is responsible for communications I make?**

You are responsible for all communications which are made by you from a CB station.

**§95.416 (CB Rule 16) Do I have to limit the length of my communications?**

- (a) You must limit your CB communications to the minimum practical time.
- (b) If you are communicating with another CB station or stations, you, and the stations communicating with you, must limit each of your conversations to no more than five continuous minutes.
- (c) At the end of your conversation, you, and the stations communicating with you, must not transmit again for at least one minute.

**§95.417 (CB Rule 17) Do I identify my CB communications?**

- (a) You need not identify your CB communications.
- (b) [You are encouraged to identify your CB communications by any of the following means:
  - (1) Previously assigned CB call sign;
  - (2) K prefix followed by operator initials and residence zip code;
  - (3) Name; or
  - (4) Organizational description including name and any applicable operator unit number.]
- (c) [You are encouraged to use your "handle" only in conjunction with the methods of identification listed in paragraph (b) of this section.]

**§ 95.418 (CB Rule 18) How do I use my CB station in an emergency or to assist a traveler?**

(a) You must at all times and on all channels, give priority to emergency communications.

(b) When you are directly participating in emergency communications, you do not have to comply with the rule about length of transmissions (CB Rule 16, § 95.416). You must obey all other rules.

(c) You may use your CB station for communications necessary to assist a traveler to reach a destination or to receive necessary services. When you are using your CB station to assist a traveler, you do not have to obey the rule about length of transmissions (CB Rule 16, § 95.416). You must obey all other rules.

(d) You may use your CB station to transmit one-way communications concerning highway conditions to assist travelers.

[48 FR 24894, June 3, 1983, as amended at 57 FR 22442, May 28, 1992]

**§ 95.419 (CB Rule 19) May I operate my CB station transmitter by remote control?**

(a) You may not operate a CB station transmitter by radio remote control.

(b) You may operate a CB transmitter by wireline remote control if you obtain specific approval in writing from the FCC. To obtain FCC approval, you must show why you need to operate your station by wireline remote control. Send your request and justification to FCC, 1270 Fairfield Road, Gettysburg, PA 17325-7245. If you receive FCC approval, you must keep the approval as part of your station records. (See CB Rule 27, § 95.427.)

(c) Remote control means operation of a CB transmitter from any place other than the location of the CB transmitter. Direct mechanical control or direct electrical control by wire from some point on the same premises, craft or vehicle as the CB transmitter is not considered remote control.

[48 FR 24894, June 3, 1983, as amended at 57 FR 40343, Sept. 3, 1992]

**§ 95.420 (CB Rule 20) May I connect my CB station transmitter to a telephone?**

(a) You may connect your CB station transmitter to a telephone if you comply with all of the following:

(1) You or someone else must be present at your CB station and must—

(i) Manually make the connection (the connection must not be made by remote control);

(ii) Supervise the operation of the transmitter during the connection;

(iii) Listen to each communication during the connection; and

(iv) Stop all communications if there are operations in violation of these rules.

(2) Each communication during the telephone connection must comply with all of these rules.

(3) You must obey any restriction that the telephone company places on the connection of a CB transmitter to a telephone.

(b) The CB transmitter you connect to a telephone must not be shared with any other CB station.

(c) If you connect your CB transmitter to a telephone, you must use a phone patch device with has been registered with the FCC.

OTHER THINGS YOU NEED TO KNOW

**§ 95.421 (CB Rule 21) What are the penalties for violating these rules?**

(a) If the FCC finds that you have willfully or repeatedly violated the Communications Act or the FCC Rules, you may have to pay as much as \$10,000 for each violation, up to a total of \$75,000. (See section 503(b) of the Communications Act.)

(b) If the FCC finds that you have violated any section of the Communications Act or the FCC Rules, you may be ordered to stop whatever action caused the violation. (See section 312(b) of the Communications Act.)

(c) If a Federal court finds that you have willfully and knowingly violated any FCC Rule, you may be fined up to \$500 for each day you committed the violation. (See section 502 of the Communications Act.)

(d) If a Federal court finds that you have willfully and knowingly violated any provision of the Communications

Act, you may be fined up to \$10,000 or you may be imprisoned for one year, or both. (See section 501 of the Communications Act.)

[48 FR 24894, June 3, 1983, as amended at 57 FR 40343, Sept. 3, 1992]

**§95.422 (CB Rule 22) How do I answer correspondence from the FCC?**

(a) If it appears to the FCC that you have violated the Communications Act or these rules, the FCC may send you a discrepancy notice.

(b) Within the time period stated in the notice, you must answer with:

(1) A complete written statement about the apparent discrepancy;

(2) A complete written statement about any action you have taken to correct the apparent violation and to prevent it from happening again; and

(3) The name of the person operating at the time of the apparent violation.

(c) If the FCC sends you a letter asking you questions about your CB radio station or its operation, you must answer each of the questions with a complete written statement within the time period stated in the letter.

(d) You must not shorten your answer by references to other communications or notices.

(e) You must send your answer to the FCC office which sent you the notice.

(f) You must keep a copy of your answer in your station records. (See CB Rule 27, §95.427.)

**§95.423 (CB Rule 23) What must I do if the FCC tells me that my CB station is causing interference?**

(a) If the FCC tells you that your CB station is causing interference for technical reasons you must follow all instructions in the official FCC notice. (This notice may require you to have technical adjustments made to your equipment.)

(b) You must comply with any restricted hours of CB station operation which may be included in the official notice.

**§95.424 (CB Rule 24) How do I have my CB station transmitter serviced?**

(a) You may adjust an antenna to your CB transmitter and you may make radio checks. (A radio check means a one way transmission for a

short time in order to test the transmitter.)

(b) You are responsible for the proper operation of the station at all times and are expected to provide for observations, servicing and maintenance as often as may be necessary to ensure proper operation. You must have all internal repairs or internal adjustments to your CB transmitter made in accordance with the Technical Regulations (see subpart E). The internal repairs or internal adjustments should be performed by or under the immediate supervision and responsibility of a person certified as technically qualified to perform transmitter maintenance and repair duties in the private land mobile services and fixed services by an organization or committee representative of users in those services.

(c) Except as provided in paragraph (d) of this section, each internal repair and each internal adjustment of a CB transmitter in which signals are transmitted must be made using a non-radiating ("dummy") antenna.

(d) Brief test signals (signals not longer than one minute during any five minute period) using a radiating antenna may be transmitted in order to:

(1) Adjust an antenna to a transmitter;

(2) Detect or measure radiation of energy other than the intended signal; or

(3) Tune a receiver to your CB transmitter.

(Secs. 4(i) and 303(r), Communications Act of 1934, as amended, 47 U.S.C. 154(i) and 303(r), and sec. 553 of the Administrative Procedures Act, 5 U.S.C. 553)

[48 FR 24894, June 3, 1983, as amended at 49 FR 20673, May 16, 1984]

**§95.425 (CB Rule 25) May I make any changes to my CB station transmitter?**

(a) You must not make or have any one else make any internal modification to your CB transmitter.

(b) Internal modification does not include:

(1) Repair or servicing of a CB station transmitter (see CB Rule 24, §95.424); or

(2) Changing plug-in modules which were type accepted as part of your CB transmitter.

(c) You must not operate a CB transmitter which has been modified by anyone in any way, including modification to operate on unauthorized frequencies or with illegal power. (See CB Rules 9 and 11, §§95.409 and 95.411.)

**§95.426 (CB Rule 26) Do I have to make my CB station available for inspection?**

(a) If an authorized FCC representative requests to inspect your CB station, you must make your CB station and records available for inspection.

(b) A CB station includes all of the radio equipment you use.

**§95.427 (CB Rule 27) What are my station records?**

Your station records include the following documents, as applicable.

(a) A copy of each response to an FCC violation notice or an FCC letter. (See CB Rule 22, §95.422.)

(b) Each written permission received from the FCC. (See CB Rule 19, §95.419.)

**§95.428 (CB Rule 28) How do I contact the FCC?**

(a) Write to your nearest FCC Field Office if you:

(1) Want to report an interference complaint; or

(2) Want to know if the FCC has type-accepted a transmitter for CB.

(b) Write to the FCC, Wireless Telecommunications Bureau, Private Wireless Division, Washington, DC 20554, if you have questions about the RC Rules.

[48 FR 24894, June 3, 1983, as amended at 48 FR 41416, Sept. 15, 1983; 60 FR 50123, Sept. 28, 1995]

**Subpart E—Technical Regulations**

SOURCE: 53 FR 36789, Sept. 22, 1988, unless otherwise noted.

GENERAL PROVISIONS

**§95.601 Basis and purpose.**

This section provides the technical standards to which each *transmitter* (apparatus that converts electrical energy received from a source into RF (radio frequency) energy capable of being radiated) used or intended to be used in a station authorized in any of the Personal Radio Services must comply.

This section also provides requirements for obtaining type acceptance or type certification for such transmitters. The Personal Radio Services are the GMRS (General Mobile Radio Service)—subpart A, the Family Radio Service (FRS)—subpart B, the R/C (Radio Control Radio Service)—subpart C, the CB (Citizens Band Radio Service)—subpart D, and the Low Power Radio Service (LPRS)—subpart G.

[61 FR 46566, Sept. 4, 1996]

EFFECTIVE DATE NOTE: At 61 FR 46566, Sept. 4, 1996, §95.601 was revised, effective Oct. 4, 1996. For the convenience of the user, the superseded text is set forth as follows:

**§95.601 Basis and purpose.**

These rules provide the technical standards to which each transmitter (apparatus that converts electrical energy received from a source into RF (radio frequency) energy capable of being radiated) used or intended to be used in a station authorized in any of the Personal Radio Services must comply. They also provide requirements for obtaining type acceptance of such transmitters. The Personal Radio Services are the GMRS (General Mobile Radio Service), the Family Radio Service (FRS), the R/C (Radio Control Radio Service), and the CB (Citizens Band Radio Service). For operating rules, see part 95, subpart A—GMRS; subpart B—FRS; subpart C—R/C; and subpart D—CB.

[61 FR 28769, June 6, 1996]

**§95.603 Type acceptance or certification required.**

(a) Each *GMRS transmitter* (a transmitter that operates or is intended to operate at a station authorized in the GMRS) must be type accepted.

(b) Each *R/C transmitter* (a transmitter that operates or is intended to operate at a station authorized in the R/C) must be type accepted, except one that transmits only in the 26–27 MHz frequency band and is *crystal controlled* (where the transmitted frequency is established by a *crystal* (a quartz piezoelectric element)).

(c) Each *CB transmitter* (a transmitter that operates or is intended to operate at a station authorized in the CB) must be type accepted. No CB transmitter type accepted pursuant to an application filed prior to September 10, 1976, shall be manufactured or marketed.

(d) Each FRS unit (a transmitter that operates or is intended to operate

in the FRS) must be certified for use in the FRS in accordance with Subpart J of Part 2 of this chapter.

(e) Each Low Power Radio Service transmitter (a transmitter that operates or is intended to operate in the LPRS) must be type accepted.

[53 FR 36789, Sept. 22, 1988, as amended at 61 FR 28769, June 6, 1996; 61 FR 46567, Sept. 4, 1996]

EFFECTIVE DATE NOTE: At 61 FR 46567, Sept. 4, 1996, §95.603 was amended by adding paragraph (e), effective Oct. 4, 1996.

**§95.605 Type acceptance and certification procedures.**

Any entity may request type acceptance for its transmitter when the transmitter is used in the GMRS, R/C, CB, IVDS, or LPRS following the procedures in part 2 of this chapter.

Any entity may request certification for its transmitter when the transmitter is used in the FRS following the procedures in part 2 of this chapter.

[61 FR 46567, Sept. 4, 1996]

EFFECTIVE DATE NOTE: At 61 FR 46567, Sept. 4, 1996, §95.605 was revised, effective Oct. 4, 1996. For the convenience of the user, the superseded text is set forth as follows:

**§95.605 Type acceptance and certification procedures.**

Any entity must request type acceptance for its transmitter when the transmitter is used in the GMRS, R/C or CB Radio Service, or IVDS following the procedures in part 2 of this chapter. Any entity must request certification for its transmitter when the transmitter is used in the FRS following the procedures in subpart J of part 2 of this chapter.

[61 FR 28769, June 6, 1996]

**§95.607 CB transmitter modification.**

Only the holder of the grant of authorization of the particular type accepted CB transmitter may make the modifications permitted under the provisions for type acceptance (see part 2 of this chapter.) No grantee shall make any of the following modifications to the transmitter without prior written permission from the FCC (Federal Communications Commission):

(a) The addition of any accessory or device not specified in the application for type acceptance and authorized by the FCC in granting the type acceptance;

(b) The addition of any switch, control or external connection;

(c) Any modification to provide for additional transmitting frequencies, increased modulation level, a different form of modulation, or increased TP (RF transmitter power expressed in W (watts), either *mean power* (TP averaged over at least 30 cycles of the lowest modulating frequency, typically 0.1 seconds at maximum power) or *peak envelope power* (TP averaged during 1 RF cycle at the highest crest of the modulation envelope), as measured at the transmitter output antenna terminals.)

TECHNICAL STANDARDS

**§95.621 GMRS transmitter channel frequencies.**

(a) The GMRS transmitter *channel frequencies* (reference frequencies from which the carrier frequency, suppressed or otherwise, may not deviate by more than the specified frequency tolerance) are 462.5500, 462.5625, 462.5750, 462.5875, 462.6000, 462.6125, 462.6250, 462.6375, 462.6500, 462.6625, 462.6750, 462.6875, 462.7000, 462.7125, 462.7250, 467.5500, 467.5750, 467.6000, 467.6250, 467.6500, 467.6750, 467.7000, and 467.7250.

NOTE: Certain GMRS transmitter channel frequencies are authorized only for certain station classes and station locations. See part 95, subpart A.

(b) Each GMRS transmitter for mobile station, small base station and control station operation must be maintained within a frequency tolerance of 0.0005%. Each GMRS transmitter for base station (except small base), mobile relay station or fixed station operation must be maintained within a frequency tolerance of 0.00025%.

[53 FR 47718, Nov. 25, 1988]

**§95.623 R/C transmitter channel frequencies.**

(a) The R/C transmitter channel frequencies are:

	MHz
26.995	72.03
27.045	72.05
27.095	72.07
27.145	72.09
27.195	72.11
27.255	72.13
72.01	72.15

§ 95.625

72.17	72.89
72.19	72.91
72.21	72.93
72.23	72.95
72.25	72.97
72.27	72.99
72.29	75.41
72.31	75.43
72.33	75.45
72.35	75.47
72.37	75.49
72.39	75.51
72.41	75.53
72.43	75.55
72.45	75.57
72.47	75.59
72.49	75.61
72.51	75.63
72.53	75.65
72.55	75.67
72.57	75.69
72.59	75.71
72.61	75.73
72.63	75.75
72.65	75.77
72.67	75.79
72.69	75.81
72.71	75.83
72.73	75.85
72.75	75.87
72.77	75.89
72.79	75.91
72.81	75.93
72.83	75.95
72.85	75.97
72.87	75.99

NOTE: Certain R/C transmitter channel frequencies are authorized to operate only certain kinds of devices (see part 95, subpart C.)

(b) Each R/C transmitter that transmits in the 26–27 MHz frequency band with a mean TP of 2.5 W or less and that is used solely by the operator to turn on and/or off a device at a remote location, other than a device used solely to attract attention, must be maintained within a frequency tolerance of 0.01%. All other R/C transmitters that transmit in the 26–27 MHz frequency band must be maintained within a frequency tolerance of 0.005%. Except as noted in paragraph (c) of this section, R/C transmitters capable of operation in the 72–76 MHz band must be maintained within a frequency tolerance of 0.005%.

(c) All R/C transmitters capable of operation in the 72–76 MHz band that are manufactured in or imported into the United States, on or after March 1, 1992, or are marketed on or after March 1, 1993, must be maintained within a

47 CFR Ch. I (10–1–96 Edition)

frequency tolerance of 0.002%. R/C transmitters operating in the 72–76 MHz band and marketed before March 1, 1993, may continue to be operated with a frequency tolerance of 0.005% until March 1, 1998.

[53 FR 36789, Sept. 22, 1988; 53 FR 52713, Dec. 29, 1988; 56 FR 15837, Apr. 18, 1991]

**§95.625 CB transmitter channel frequencies.**

(a) The CB transmitter channel frequencies are:

Channel No.	(MHz)
1	26.965
2	26.975
3	26.985
4	27.005
5	27.015
6	27.025
7	27.035
8	27.055
9	27.065
10	27.075
11	27.085
12	27.105
13	27.115
14	27.125
15	27.135
16	27.155
17	27.165
18	27.175
19	27.185
20	27.205
21	27.215
22	27.225
23	27.255
24	27.235
25	27.245
26	27.265
27	27.275
28	27.285
29	27.295
30	27.305
31	27.315
32	27.325
33	27.335
34	27.345
35	27.355
36	27.365
37	27.375
38	27.385
39	27.395
40	27.405

(b) Each CB transmitter must be maintained within a frequency tolerance of 0.005%.

**§95.627 FRS unit channel frequencies.**

(a) The FRS unit channel frequencies are:

Channel No.	(MHz)
1	462.5625
2	462.5875
3	462.6125

Channel No.	(MHz)
4 .....	462.6375
5 .....	462.6625
6 .....	462.6875
7 .....	462.7125
8 .....	467.5625
9 .....	467.5875
10 .....	467.6125
11 .....	467.6375
12 .....	467.6625
13 .....	467.6875
14 .....	467.7125

(b) Each FRS unit must be maintained within a frequency tolerance of 0.00025%.

[61 FR 28769, June 6, 1996]

**§95.629 LPRS transmitter frequencies.**

(a) LPRS transmitters may operate on any frequency listed in paragraphs (b), (c), and (d) of this section. Channels 19, 20, 50, and 151-160 are available exclusively for law enforcement tracking purposes. AMTS transmissions are limited to the 216.750-217.000 MHz band for low power point-to-point network control communications by AMTS coast stations. Other AMTS transmissions in the 216-217 MHz band are prohibited.

(b) *Standard band channels.* (1) The following table indicates standard band frequencies. The channel bandwidth is 25 kHz.

Channel No.	Center frequency (MHz)
1 .....	216.0125
2 .....	216.0375
3 .....	216.0625
4 .....	216.0875
5 .....	216.1125
6 .....	216.1375
7 .....	216.1625
8 .....	216.1875
9 .....	216.2125
10 .....	216.2375
11 .....	216.2625
12 .....	216.2875
13 .....	216.3125
14 .....	216.3375
15 .....	216.3625
16 .....	216.3875
17 .....	216.4125
18 .....	216.4375
19 .....	216.4625
20 .....	216.4875
21 .....	216.5125
22 .....	216.5375
23 .....	216.5625
24 .....	216.5875
25 .....	216.6125
26 .....	216.6375
27 .....	216.6625
28 .....	216.6875

Channel No.	Center frequency (MHz)
29 .....	216.7125
30 .....	216.7375
31 .....	216.7625
32 .....	216.7875
33 .....	216.8125
34 .....	216.8375
35 .....	216.8625
36 .....	216.8875
37 .....	216.9125
38 .....	216.9375
39 .....	216.9625
40 .....	216.9875

(2) LPRS transmitters operating on standard band channels must be maintained within a frequency stability of 50 parts per million.

(c) *Extra band channels.* (1) The following table indicates extra band frequencies. The channel bandwidth is 50 kHz.

Channel No.	Center frequency (MHz)
41 .....	216.025
42 .....	216.075
43 .....	216.125
44 .....	216.175
45 .....	216.225
46 .....	216.275
47 .....	216.325
48 .....	216.375
49 .....	216.425
50 .....	216.475
51 .....	216.525
52 .....	216.575
53 .....	216.625
54 .....	216.675
55 .....	216.725
56 .....	216.775
57 .....	216.825
58 .....	216.875
59 .....	216.925
60 .....	216.975

(2) LPRS transmitters operating on extra band channels must be maintained within a frequency stability of 50 parts per million.

(d) *Narrowband channels.* (1) The following table indicates narrowband frequencies. The channel bandwidth is 5 kHz and the authorized bandwidth is 4 kHz.

Channel No.	Center frequency (MHz)
61 .....	216.0025
62 .....	216.0075
63 .....	216.0125
64 .....	216.0175
65 .....	216.0225
66 .....	216.0275
67 .....	216.0325

Channel No.	Center frequency (MHz)	Channel No.	Center frequency (MHz)
68	216.0375	140	216.3975
69	216.0425	141	216.4025
70	216.0475	142	216.4075
71	216.0525	143	216.4125
72	216.0575	144	216.4175
73	216.0625	145	216.4225
74	216.0675	146	216.4275
75	216.0725	147	216.4325
76	216.0775	148	216.4375
77	216.0825	149	216.4425
78	216.0875	150	216.4475
79	216.0925	151	216.4525
80	216.0975	152	216.4575
81	216.1025	153	216.4625
82	216.1075	154	216.4675
83	216.1125	155	216.4725
84	216.1175	156	216.4775
85	216.1225	157	216.4825
86	216.1275	158	216.4875
87	216.1325	159	216.4925
88	216.1375	160	216.4975
89	216.1425	161	216.5025
90	216.1475	162	216.5075
91	216.1525	163	216.5125
92	216.1575	164	216.5175
93	216.1625	165	216.5225
94	216.1675	166	216.5275
95	216.1725	167	216.5325
96	216.1775	168	216.5375
97	216.1825	169	216.5425
98	216.1875	170	216.5475
99	216.1925	171	216.5525
100	216.1975	172	216.5575
101	216.2025	173	216.5625
102	216.2075	174	216.5675
103	216.2125	175	216.5725
104	216.2175	176	216.5775
105	216.2225	177	216.5825
106	216.2275	178	216.5875
107	216.2325	179	216.5925
108	216.2375	180	216.5975
109	216.2425	181	216.6025
110	216.2475	182	216.6075
111	216.2525	183	216.6125
112	216.2575	184	216.6175
113	216.2625	185	216.6225
114	216.2675	186	216.6275
115	216.2725	187	216.6325
116	216.2775	188	216.6375
117	216.2825	189	216.6425
118	216.2875	190	216.6475
119	216.2925	191	216.6525
120	216.2975	192	216.6575
121	216.3025	193	216.6625
122	216.3075	194	216.6675
123	216.3125	195	216.6725
124	216.3175	196	216.6775
125	216.3225	197	216.6825
126	216.3275	198	216.6875
127	216.3325	199	216.6925
128	216.3375	200	216.6975
129	216.3425	201	216.7025
130	216.3475	202	216.7075
131	216.3525	203	216.7125
132	216.3575	204	216.7175
133	216.3625	205	216.7225
134	216.3675	206	216.7275
135	216.3725	207	216.7325
136	216.3775	208	216.7375
137	216.3825	209	216.7425
138	216.3875	210	216.7475
139	216.3925	211	216.7525



Channel No.	Center frequency (MHz)
212	216.7575
213	216.7625
214	216.7675
215	216.7725
216	216.7775
217	216.7825
218	216.7875
219	216.7925
220	216.7975
221	216.8025
222	216.8075
223	216.8125
224	216.8175
225	216.8225
226	216.8275
227	216.8325
228	216.8375
229	216.8425
230	216.8475
231	216.8525
232	216.8575
233	216.8625
234	216.8675
235	216.8725
236	216.8775
237	216.8825
238	216.8875
239	216.8925
240	216.8975
241	216.9025
242	216.9075
243	216.9125
244	216.9175
245	216.9225
246	216.9275
247	216.9325
248	216.9375
249	216.9425
250	216.9475
251	216.9525
252	216.9575
253	216.9625
254	216.9675
255	216.9725
256	216.9775
257	216.9825
258	216.9875
259	216.9925
260	216.9975

(2) LPRS transmitters operating on narrowband channels must be maintained within a frequency stability of 1.5 parts per million.

[61 FR 46567, Sept. 4, 1996]

EFFECTIVE DATE NOTE: At 61 FR 46567, Sept. 4, 1996, §95.629 was redesignated as §95.631 and new §95.629 was added, effective Oct. 4, 1996.

**§95.631 Emission types.**

(a) A GMRS transmitter must transmit only emission types A1D, F1D, G1D, H1D, J1D, R1D, A3E, F3E, G3E, H3E, J3E or R3E. A non-voice emission is limited to selective calling or tone-operated squelch tones to establish or

continue voice communications. See §95.181 (g) and (h).

(b) An R/C transmitter may transmit any appropriate non-voice emission which meets the emission limitations of §95.633.

(c) A CB transmitter may transmit only emission types A1D, H1D, J1D, R1D, A3E, H3E, J3E, R3E. A non-voice emission is limited to selective calling or tone-operated squelch tones to establish or continue voice communications. See §95.412 (b) and (c).

(d) An FRS unit may transmit only emission type F3E. A non-voice emission is limited to selective calling or tone-operated squelch tones to establish or continue voice communications.

(e) No GMRS or CB transmitter shall employ a digital modulation or emission.

(f) No GMRS, CB or R/C transmitter shall transmit non-voice data.

(g) An LPRS station may transmit any emission type appropriate for communications in this service. Two-way voice communications, however, are prohibited.

[53 FR 36789, Sept. 22, 1988. Redesignated and amended at 61 FR 28769, June 6, 1996, and further redesignated and amended at 61 FR 46567, 46568, Sept. 4, 1996]

EFFECTIVE DATE NOTE: At 61 FR 46567, 46568, Sept. 4, 1996, §95.631 was redesignated as §95.633 and new §95.631 was redesignated from §95.629 and amended by adding paragraph (g), effective Oct. 4, 1996.

**§95.633 Emission bandwidth.**

(a) The *authorized bandwidth* (maximum permissible bandwidth of a transmission) for emission type H1D, J1D, R1D, H3E, J3E or R3E is 4 kHz. The authorized bandwidth for emission type A1D or A3E is 8 kHz. The authorized bandwidth for emission type F1D, G1D, F3E or G3E is 20 kHz.

(b) The authorized bandwidth for any emission type transmitted by an R/C transmitter is 8 kHz.

(c) The authorized bandwidth for emission type F3E transmitted by a FRS unit is 12.5 kHz.

(d) For transmitters in the LPRS:

(1) The authorized bandwidth for narrowband frequencies is 4 kHz and the channel bandwidth is 5 kHz

(2) The channel bandwidth for standard band frequencies is 25 kHz.

(3) The channel bandwidth for extra band frequencies is 50 kHz.

(4) AMTS stations may use the 216.750–217.000 MHz band as a single 250 kHz channel so long as the signal is attenuated as specified in §95.635(c).

[53 FR 36789, Sept. 22, 1988. Redesignated and amended at 61 FR 28769, June 6, 1996, and further redesignated and amended at 61 FR 46567, 46568, Sept. 4, 1996]

EFFECTIVE DATE NOTE: At 61 FR 46567, 46568, Sept. 4, 1996, §95.633 was redesignated as §95.635 and new §95.633 was redesignated from §95.631 and amended by adding paragraph (d), effective Oct. 4, 1996.

**§95.635 Unwanted radiation.**

(a) In addition to the procedures in part 2, the following requirements apply to each transmitter both with and without the connection of all attachments acceptable for use with the transmitter, such as an external speaker, microphone, power cord, antenna, etc.

(b) The power of each unwanted emission shall be less than TP as specified in the applicable paragraph:

Transmitter	Emission type	Applicable paragraphs
GMRS .....	A1D, A3E, F1D, G1D, F3E, G3E with filtering .....	(1), (3), (7)
	A1D, A3E, F1D, G1D, F3E, G3E without filtering .....	(5), (6), (7)
FRS .....	H1D, J1D, R1D, H3E, J3E, R3E .....	(2), (4), (7)
	F3E with filtering .....	(1), (3), (7)
Note: Filtering refers to the requirement in §95.635(b) R/C:		
27 MHz band .....	As specified in §95.629(b) .....	(1), (3), (7)
72–76 MHz band .....	As specified in §95.629(b) .....	(1), (3), (7), (10), (11), (12)
CB .....	A1D, A3E .....	(1), (3), (8), (9)
	H1D, J1D, R1D, H3E, J3E, R3E .....	(2), (4), (8), (9)
	A1D, A3E type accepted before September 10, 1976 .....	(1), (3), (7)
	H1D, J1D, R1D, H3E, J3E, R3E type accepted before September 10, 1986.	(2), (4), (7)

(c) For transmitters designed to operate in the LPRS, emissions shall be attenuated in accordance with the following:

(1) Emissions for LPRS transmitters operating on standard band channels (25 kHz) shall be attenuated below the unmodulated carrier in accordance with the following:

(i) Emissions 12.5 kHz to 22.5 kHz away from the channel center frequency: at least 30 dB; and

(ii) Emissions more than 22.5 kHz away from the channel center frequency: at least  $43 + 10\log(\text{carrier power in watts})$  dB.

(2) Emissions for LPRS transmitters operating on extra band channels (50 kHz) shall be attenuated below the unmodulated carrier in accordance with the following:

(i) Emissions 25 kHz to 35 kHz from the channel center frequency: at least 30 dB; and

(ii) Emissions more than 35 kHz away from the channel center frequency: at least  $43 + 10\log(\text{carrier power in watts})$  dB.

(3) Emissions for LPRS transmitters operating on narrowband channels (5 kHz) shall be attenuated below the power (P) of the highest emission, measured in peak values, contained within the authorized bandwidth (4 kHz) in accordance with the following:

(i) On any frequency within the authorized bandwidth: Zero dB;

(ii) On any frequency removed from the center of the authorized bandwidth by a displacement frequency ( $f_d$  in kHz) of more than 2 kHz up to and including 3.75 kHz: The lesser of  $30 + 20(f_d - 2)$  dB, or  $55 + 10 \log(P)$ , or 65 dB; and

(iii) On any frequency beyond 3.75 kHz removed from the center of the authorized bandwidth: At least  $55 + 10 \log(P)$  dB.

(4) Emissions from AMTS transmitters using a single 250 kHz channel shall be attenuated below the unmodulated carrier in accordance with the following:

(i) Emissions from 125 kHz to 135 kHz away from the channel center frequency: at least 30 dB; and

(ii) Emissions more than 135 kHz away from the channel center frequency; at least  $43 + 10\log(\text{carrier power in watts})$  dB.

[53 FR 36789, Sept. 22, 1988, as amended at 56 FR 15837, Apr. 18, 1991. Redesignated and amended at 61 FR 28769, 28770, June 6, 1996, and further redesignated and amended at 61 FR 46567, 46568, Sept. 4, 1996]

EFFECTIVE DATE NOTE: At 61 FR 46567, 46568, Sept. 4, 1996, §95.635 was redesignated as §95.637 and new §95.635 was redesignated from §95.633 and amended by adding paragraph (c), effective Oct. 4, 1996.

#### §95.637 Modulation standards.

(a) A GMRS transmitter that transmits emission types F1D, G1D, or G3E must not exceed a peak frequency deviation of plus or minus 5 kHz. A GMRS transmitter that transmits emission type F3E must not exceed a peak frequency deviation of plus or minus 5 kHz. A FRS unit that transmits emission type F3E must not exceed a peak frequency deviation of plus or minus 2.5 kHz, and the audio frequency response must not exceed 3.125 kHz.

(b) Each GMRS transmitter, except a mobile station transmitter with a power output of 2.5 W or less, must automatically prevent a greater than normal audio level from causing overmodulation. The transmitter also must include audio frequency low pass filtering, unless it complies with the applicable paragraphs of §95.631 (without filtering.) The filter must be between the modulation limiter and the modulated stage of the transmitter. At any frequency ( $f$  in kHz) between 3 and 20 kHz, the filter must have an attenuation of at least  $60 \log_{10}(f/3)$  dB greater than the attenuation at 1 kHz. Above 20 kHz, it must have an attenuation of at least 50 dB greater than the attenuation at 1 kHz.

(c) When emission type A3E is transmitted, the modulation must be greater than 85% but must not exceed 100%. Simultaneous amplitude modulation and frequency or phase modulation of a transmitter are not permitted.

(d) When emission type A3E is transmitted by a CB transmitter having a TP of greater than 2.5 W, the CB trans-

mitter must automatically prevent the modulation from exceeding 100%.

(e) Each CB transmitter that transmits emission type H3E, J3E or R3E must be capable of transmitting the upper sideband. The capability of also transmitting the lower sideband is permitted.

[53 FR 36789, Sept. 22, 1988. Redesignated and amended at 61 FR 28769, 28770, June 6, 1996, and further redesignated at 61 FR 46567, Sept. 4, 1996]

EFFECTIVE DATE NOTE: At 61 FR 46567, Sept. 4, 1996, §95.637 was redesignated as §95.639 and new §95.637 was redesignated from §95.635, effective Oct. 4, 1996.

#### §95.639 Maximum transmitter power.

(a) No GMRS transmitter, under any condition of modulation, shall exceed:

(1) 50 W *Carrier power* (average TP during one unmodulated RF cycle) when transmitting emission type A1D, F1D, G1D, A3E, F3E or G3E.

(2) 50 W peak envelope TP when transmitting emission type H1D, J1D, R1D, H3E, J3E or R3E.

(b) No R/C transmitter, under any condition of modulation, shall exceed a carrier power or peak envelope TP (single-sideband only) of:

(1) 4 W in the 26-27 MHz frequency band, except on channel frequency 27.255 MHz;

(2) 25 W on channel frequency 27.255 MHz;

(3) 0.75 W in the 72-76 MHz frequency band.

(c) No CB transmitter, under any condition of modulation, shall exceed:

(1) 4 W Carrier power when transmitting emission type A1D or A3E;

(2) 12 W peak envelope TP when transmitting emission type H1D, J1D, R1D, H3E, J3E or R3E. Each CB transmitter which transmits emission type H3E, J3E or R3E must automatically prevent the TP from exceeding 12 W peak envelope TP or the manufacturer's rated peak envelope TP, whichever is less.

(d) No FRS unit, under any condition of modulation, shall exceed 0.500 W effective radiated power (ERP).

## § 95.645

(e) The maximum transmitter output power authorized for LPRS stations is 100 mW.

[53 FR 36789, Sept. 22, 1988; 53 FR 44144, Nov. 1, 1988. Redesignated and amended at 61 FR 28769, 28770, June 6, 1996, and further redesignated and amended at 61 FR 46567, 46569, Sept. 4, 1996]

EFFECTIVE DATE NOTE: At 61 FR 46567, 46569, Sept. 4, 1996, § 95.639 was redesignated from § 95.637 and amended by adding paragraph (e), effective Oct. 4, 1996.

### TYPE ACCEPTANCE REQUIREMENTS

#### § 95.645 Control accessibility.

(a) No control, switch or other type of adjustment which, when manipulated, can result in a violation of the rules shall be accessible from the transmitter operating panel or from exterior of the transmitter enclosure.

(b) An R/C transmitter which incorporates plug-in frequency determining modules which are changed by the user must be type accepted with the modules. Each module must contain all of the frequency determining circuitry including the oscillator. Plug-in crystals are not considered modules and must not be accessible to the user.

[53 FR 36789, Sept. 22, 1988. Redesignated at 61 FR 28769, June 6, 1996, and further redesignated at 61 FR 46567, Sept. 4, 1996]

EFFECTIVE DATE NOTE: At 61 FR 46567, Sept. 4, 1996, § 95.645 was redesignated as § 95.647 and new § 95.645 was redesignated from § 95.643, effective Oct. 4, 1996.

#### § 95.647 FRS unit and R/C transmitter antennas.

The antenna of each FRS unit, and the antenna of each R/C station transmitting in the 72–76 MHz band, must be an integral part of the transmitter. The antenna must have no gain (as compared to a half-wave dipole) and must be vertically polarized.

[61 FR 28770, June 6, 1996. Redesignated at 61 FR 46567, Sept. 4, 1996]

EFFECTIVE DATE NOTE: At 61 FR 46567, Sept. 4, 1996, § 95.647 was redesignated as § 95.649 and new § 95.647 was redesignated from § 95.645, effective Oct. 4, 1996.

#### § 95.649 Power capability.

No CB, R/C, LPRS transmitter, or FRS unit shall incorporate provisions for increasing its transmitter power to

## 47 CFR Ch. I (10–1–96 Edition)

any level in excess of the limits specified in § 95.639.

[61 FR 46569, Sept. 4, 1996]

EFFECTIVE DATE NOTE: At 61 FR 46567, 46569, Sept. 4, 1996, § 95.649 was redesignated as § 95.651 and new § 95.649 was redesignated from § 95.647 and revised, effective Oct. 4, 1996. For the convenience of the user, the superseded text is set forth as follows:

#### § 95.649 Power capability.

No CB or R/C station transmitter or FRS unit shall incorporate provisions for increasing its transmitter power to any level in excess of the limit specified in § 95.637.

[61 FR 28770, June 6, 1996]

#### § 95.651 Crystal control required.

All transmitters used in the Personal Radio Services must be crystal controlled, except an R/C station that transmits in the 26–27 MHz frequency band, a FRS unit, and a LPRS unit.

[61 FR 46569, Sept. 4, 1996]

EFFECTIVE DATE NOTE: At 61 FR 46567, 46569, Sept. 4, 1996, § 95.651 was redesignated as § 95.653 and new § 95.651 was redesignated from § 95.649 and revised, effective Oct. 4, 1996. For the convenience of the user, the superseded text is set forth as follows:

#### § 95.651 Crystal control required.

All transmitters used in the Personal Radio Services must be crystal controlled, except an R/C station that transmits in the 26–27 MHz frequency band, and a FRS unit.

[61 FR 28770, June 6, 1996]

#### § 95.653 Instructions and warnings.

(a) A user's instruction manual must be supplied with each transmitter marketed, and one copy (a draft or preliminary copy is acceptable provided a final copy is provided when completed) must be forwarded to the FCC with each request for type acceptance.

(b) The instruction manual must contain all information necessary for the proper installation and operation of the transmitter including:

(1) Instructions concerning all controls, adjustments and switches that may be operated or adjusted without resulting in a violation of the rules.

(2) Warnings concerning any adjustment that could result in a violation of the rules or that is recommended to be performed by or under the immediate

supervision and responsibility of a person certified as technically qualified to perform transmitter maintenance and repair duties in the private land mobile services and fixed services by an organization or committee representative of users of those services.

(3) Warnings concerning the replacement of any transmitter component (crystal, semiconductor, etc.) that could result in a violation of the rules.

(4) For a CMRS transmitter, warnings concerning licensing requirements and information concerning license application procedures.

[53 FR 36789, Sept. 22, 1988. Redesignated at 61 FR 28769, June 6, 1996, and further redesignated at 61 FR 46567, Sept. 4, 1996]

EFFECTIVE DATE NOTE: At 61 FR 46567, Sept. 4, 1996, §95.653 was redesignated as §95.655 and new §95.653 was redesignated from §95.651, effective Oct. 4, 1996.

#### §95.655 Frequency capability.

(a) No transmitter will be type accepted for use in the CB service if it is equipped with a frequency capability not listed in §95.625, and no transmitter will be type accepted for use in the GMRS if it is equipped with a frequency capability not listed in §95.621, unless such transmitter is also type accepted for use in another radio service for which the frequency is authorized and for which type acceptance is also required. (Transmitters with frequency capability for the Amateur Radio Services, Military Affiliate Radio System and Civil Air Patrol will not be type accepted.)

(b) All frequency determining circuitry (including crystals) and programming controls in each CB transmitter and in each GMRS transmitter must be internal to the transmitter and must not be accessible from the exterior of the transmitter operating panel or from the exterior of the transmitter enclosure.

(c) No add-on device, whether internal or external, the function of which is to extend the transmitting frequency capability of a CB transmitter beyond its original capability, shall be manufactured, sold or attached to any CB station transmitter.

[53 FR 47718, Nov. 25, 1988. Redesignated at 61 FR 28769, June 6, 1996, and further redesignated at 61 FR 46567, Sept. 4, 1996]

EFFECTIVE DATE NOTE: At 61 FR 46567, Sept. 4, 1996, §95.655 was redesignated from §95.653, effective Oct. 4, 1996.

#### ADDITIONAL TYPE ACCEPTANCE REQUIREMENTS FOR CB TRANSMITTERS

#### §95.665 [Reserved]

#### §95.667 CB transmitter power.

The dissipation rating of all the semiconductors or electron tubes which supply RF power to the antenna terminals of each CB transmitter must not exceed 10 W. For semiconductors, the dissipation rating is the greater of the collector or device dissipation value established by the manufacturer of the semiconductor. These values may be temperature de-rated by no more than 50° C. For an electron tube, the dissipation rating is the Intermittent Commercial and Amateur Service plate dissipation value established by the manufacturer of the electron tube.

[53 FR 36789, Sept. 22, 1988. Redesignated at 61 FR 28769, June 6, 1996, and further redesignated at 61 FR 46567, Sept. 4, 1996]

EFFECTIVE DATE NOTE: At 61 FR 46567, Sept. 4, 1996, §95.667 was redesignated as §95.669 and new §95.667 was redesignated from §95.665, effective Oct. 4, 1996.

#### §95.669 External controls.

(a) Only the following external transmitter controls, connections or devices will normally be permitted in a CB transmitter:

(1) Primary power connection. (Circuitry or devices such as rectifiers, transformers, or inverters which provide the nominal rated transmitter primary supply voltage may be used without voiding the transmitter type acceptance.)

(2) Microphone connection.

(3) Antenna terminals.

(4) Audio frequency power amplifier output connector and selector switch.

(5) On-off switch for primary power to transmitter. This switch may be combined with receiver controls such as the receiver on-off switch and volume control.

(6) Upper/lower sideband selector switch (for a transmitter that transmits emission type H3E, J3E or R3E).

(7) Carrier level selector control (for a transmitter that transmits emission type H3E, J3E or R3E.) This control

## § 95.671

may be combined with the sideband selector switch.

(8) Channel frequency selector switch.

(9) Transmit/receive selector switch.

(10) Meter(s) and selector switch(es) for monitoring transmitter performance.

(11) Pilot lamp(s) or meter(s) to indicate the presence of RF output power or that the transmitter control circuits are activated to transmit.

(b) The FCC may authorize additional controls, connections or devices after considering the functions to be performed by such additions.

[53 FR 36789, Sept. 22, 1988. Redesignated at 61 FR 28769, June 6, 1996, and further redesignated at 61 FR 46567, Sept. 4, 1996]

EFFECTIVE DATE NOTE: At 61 FR 46567, Sept. 4, 1996, § 95.669 was redesignated as § 95.671 and new § 95.669 was redesignated from § 95.667, effective Oct. 4, 1996.

### § 95.671 Serial number.

The serial number of each CB transmitter must be engraved on the transmitter chassis.

[53 FR 36789, Sept. 22, 1988. Redesignated at 61 FR 28769, June 6, 1996, and further redesignated at 61 FR 46567, Sept. 4, 1996]

EFFECTIVE DATE NOTE: At 61 FR 46567, Sept. 4, 1996, § 95.671 was redesignated as § 95.673 and new § 95.671 was redesignated from § 95.669, effective Oct. 4, 1996.

### § 95.673 Copy of rules.

A copy of part 95, subpart D, of the FCC Rules, current at the time of packing of the transmitter, must be furnished with each CB transmitter marketed.

[53 FR 36789, Sept. 22, 1988. Redesignated at 61 FR 28769, June 6, 1996, and further redesignated at 61 FR 46567, Sept. 4, 1996]

EFFECTIVE DATE NOTE: At 61 FR 46567, Sept. 4, 1996, § 95.673 was redesignated from § 95.671, effective Oct. 4, 1996.

## APPENDIX 1 TO SUBPART E—GLOSSARY OF TERMS

The definitions used in part 95, subpart E are:

*Authorized bandwidth.* Maximum permissible bandwidth of a transmission.

*Carrier power.* Average TP during one unmodulated RF cycle.

*CB.* Citizens Band Radio Service.

## 47 CFR Ch. I (10–1–96 Edition)

*CB transmitter.* A transmitter that operates or is intended to operate at a station authorized in the CB.

*Channel frequencies.* Reference frequencies from which the carrier frequency, suppressed or otherwise, may not deviate by more than the specified frequency tolerance.

*Crystal.* Quartz piezo-electric element.

*Crystal controlled.* Use of a crystal to establish the transmitted frequency.

*dB.* Decibels.

*FCC.* Federal Communications Commission.

*Filtering.* Refers to the requirement in § 95.633(b).

*FRS.* Family Radio Service.

*GMRS.* General Mobile Radio Service.

*GMRS transmitter.* A transmitter that operates or is intended to operate at a station authorized in the GMRS.

*Harmful interference.* Any transmission, radiation or induction that endangers the functioning of a radionavigation or other safety service or seriously degrades, obstructs or repeatedly interrupts a radiocommunication service operating in accordance with applicable laws, treaties and regulations.

*Mean power.* TP averaged over at least 30 cycles of the lowest modulating frequency, typically 0.1 seconds at maximum power.

*Peak envelope power.* TP averaged during 1 RF cycle at the highest crest of the modulation envelope.

*R/C.* Radio Control Radio Service.

*R/C transmitter.* A transmitter that operates or is intended to operate at a station authorized in the R/C.

*RF.* Radio frequency.

*Transmitter.* Apparatus that converts electrical energy received from a source into RF energy capable of being radiated.

*TP.* RF transmitter power expressed in W, either mean or peak envelope, as measured at the transmitter output antenna terminals.

*W.* Watts.

[53 FR 36789, Sept. 22, 1988, as amended at 61 FR 28770, June 6, 1996]

## Subpart F—Interactive Video and Data Service (IVDS)

### GENERAL PROVISIONS

SOURCE: 57 FR 8275, Mar. 9, 1992, unless otherwise noted.

### § 95.801 Scope.

This subpart sets out the regulations governing the licensing and operation of an Interactive Video and Data Service (IVDS) system. The rules in this subpart are to be read in conjunction

with applicable requirements contained elsewhere in the Commission's Rules.

**§95.803 IVDS description.**

(a) An IVDS system is a point-to-multipoint, multipoint-to-point, short distance communications service for its licensees to provide information, products, or services to, and allow interactive responses from, subscribers in the licensee's service area.

(b) The components of each IVDS system are its administrative apparatus, its response transmitter units (RTUs), and one or more cell transmitter stations (CTSs). RTUs may be used in any location within the service area. Each IVDS system is authorized for a specific service area and frequency segment. There can be a maximum of two IVDS systems per service area. There are two frequency segments available for each service area.

(c) Each IVDS system service area is one of the cellular system service areas as defined by the Commission.

[57 FR 8275, Mar. 9, 1992, as amended at 61 FR 32711, June 25, 1996]

**§95.805 Permissible communications.**

(a) Each IVDS system may conduct CTS-to-RTU and RTU-to-CTS communications between the system licensee and its subscriber's locations.

(b) Direct CTS-to-CTS communications within the same IVDS system are permitted.

(c) Direct RTU-to-RTU communications are prohibited. No mobile RTU in an IVDS system may be interconnected with the public switched network or any commercial mobile radio service.

(d) The licensee may use the IVDS system to interact with its subscribers concerning products and services offered, polls conducted, educational classes taught, and other activities in conjunction with video and data delivery systems.

(e) An IVDS system may provide fixed and mobile service to subscribers within its service area.

(f) No IVDS system may render a common carrier service.

[57 FR 8275, Mar. 9, 1992, as amended at 57 FR 36373, Aug. 13, 1992; 61 FR 32711, June 25, 1996]

SYSTEM LICENSE REQUIREMENTS

**§95.811 License requirements.**

(a) Each IVDS system must be licensed.

(b) Each CTS where the antenna does not exceed 6.1 meters (m) (20 feet) above ground or an existing man-made structure (other than an antenna structure) is authorized under the IVDS system license. All other CTSs must be individually licensed to the system licensee.

(c) Each component RTU in an IVDS system is authorized under the IVDS system license or if associated with an individually licensed CTS, under that CTS license.

(d) The term of each IVDS system license and each CTS license is five years.

[57 FR 8275, Mar. 9, 1992, as amended at 57 FR 36373, Aug. 13, 1992]

**§95.813 Eligibility.**

(a) An entity is eligible to hold an IVDS system license and its associated individual CTS licenses if:

(1) The entity is an individual who is not a representative of a foreign government; or

(2) The entity is a partnership and no partner is a representative of a foreign government; or

(3) The entity is a corporation organized under the laws of the United States of America; or

(4) The entity is a trust and no beneficiary is a representative of a foreign government.

(b) No entity is eligible to hold an IVDS system license if:

(1) The entity already holds an IVDS system license or has an interest in an IVDS system license for the same service area.

(2) The entity had an IVDS system license canceled within the past three years for failure to meet the construction requirements specified in §95.831.

(c) Each individually licensed CTS must also be held by the IVDS system license for the service area in which the CTS is located.

[57 FR 8275, Mar. 9, 1992, as amended at 58 FR 25952, Apr. 29, 1993]

**§ 95.815 License application.**

(a) An application for an IVDS system license may be filed by an eligible applicant for a service area only when there are less than two existing IVDS system licenses.

(b) Each application for an IVDS system license must be made on a separate FCC Form 600, and must be submitted to the Federal Communications Commission, Interactive Video and Data Service, P.O. Box 358365, Pittsburgh, PA 15251-5365. Each application for a CTS license where the CTS antenna exceeds 6.1m (20 feet) (see § 95.811(b)) must be made on a separate FCC Form 574, and must be submitted to the address set forth in § 1.1102 of this chapter.

(c) Each application shall be personally signed by the applicant, if the applicant is an individual; by one of the partners, if the applicant is a partnership; or by an officer or duly authorized employee, if the applicant is a corporation.

(d) Each application for an IVDS system license must include the following:

(1) A cover sheet specifying the applicant's name and address and the specific service area number and name as defined in § 95.803.

(2) A completed application (FCC Form 600).

(3) A plan showing how the applicant intends to minimize co-channel interference and interference to adjacent channel users and a showing that the proposed system will provide coverage (39 dbu) to at least 50 percent of the population (1990 census) or land area within the service area.

(e) Each IVDS system license is licensed for an unlimited number of CSTs that meet the 6.1 meter (20 foot) criteria.

(f) Each request by an IVDS system licensee to add, delete, or modify an individually licensed CTS (the CTS antenna exceeds 6.1m (20 feet) (See § 95.811(b))) must include the following:

(1) A cover sheet specifying the licensee's name and address and the specific service area number and name where the IVDS system is located.

(2) A description of the system after the proposed addition, deletion, or modification, including the population in the service area, the number of com-

ponent CTSs, and an explanation of how the system will satisfy the service requirements specified in § 95.831.

(3) A separate application (FCC Form 600) for each CTS that is being added or modified.

(4) The license for each CTS that is being deleted.

(g) Any application not complying with the Commission's Rules will be dismissed.

(h) Each application will be processed on a first-come-first-served basis.

[57 FR 8275, Mar. 9, 1992, as amended at 57 FR 36373, Aug. 13, 1992; 58 FR 25952, Apr. 29, 1993; 61 FR 49075, Sept. 18, 1996]

EFFECTIVE DATE NOTE: At 61 FR 49075, Sept. 18, 1996, § 95.815 was amended by revising paragraphs (b), (d)(2), and (f)(3), effective Nov. 18, 1996. For the convenience of the user, the superseded text is set forth as follows:

**§ 95.815 License application.**

\* \* \* \* \*

(b) Each application for an IVDS system license and each application for a CTS license where the CTS antenna exceeds 6.1m (20 feet) (see § 95.811(b)) must be made on a separate FCC Form 574. Each application for an IVDS system license must be submitted to the Federal Communications Commission, Interactive Video and Data Service, P.O. Box 358365, Pittsburgh, PA 15251-5365. Each application for the CTS must be submitted to the address set forth in § 1.1102 of the Commission's Rules.

\* \* \* \* \*

(d) \* \* \*  
(2) A completed application (FCC Form 574).

\* \* \* \* \*

(f) \* \* \*  
(3) A separate application (FCC Form 574) for each CTS that is being added or modified.

\* \* \* \* \*

**§ 95.816 Competitive bidding proceedings.**

(a) Mutually exclusive IVDS initial applications are subject to competitive bidding.

(b) The General Procedures set forth in 47 CFR part 1, subpart Q are applicable to competitive bidding proceedings



used to select among mutually exclusive applicants for initial IVDS licenses.

(c) The specific procedures applicable to auctioning particular IVDS licenses will be set forth by Public Notice. Generally, the following competitive bidding procedures will be used to auction mutually exclusive IVDS licenses. The Commission, however, may design and test alternative procedures.

(1) *Competitive bidding design options and mechanisms.* The Wireless Telecommunications Bureau will select competitive bidding design(s) and mechanisms in accordance with §§ 1.2103 and 1.2104 of this chapter. If simultaneous multiple round bidding is used, the Wireless Telecommunications Bureau has the discretion to vary the duration of the bidding rounds or the interval at which bids are accepted at any time before or during the course of the auction.

(2) *Forms.* (i) Applicants must submit short-form applications (FCC Form 175) as specified in Commission Public Notices. Minor deficiencies may be corrected prior to the auction. Major modifications such as changes in ownership, failure to sign an application or failure to submit required certifications will result in the dismissal of the application. See 1.2105(a) and (b) of this chapter.

(ii) Applicants must submit a long-form application (FCC Form 600) within ten (10) business days after being notified that it is the winning bidder for a license. See 1.2107(c) and (d) of this chapter.

(3) *Upfront payments.* For oral outcry bidding, applicants will be required to show the Commission or its representative, immediately prior to the auction, a cashier's check for at least \$2500 in order to get a bidding number and secure a place in the room where the bidding will take place. Bidders will be required to have \$2500 upfront money for every five licenses they win. No upfront payment will be required from applicants in single-round sealed bid auctions. See 47 CFR 1.2106.

(4) *Down payments.* See § 1.2107(b) of this chapter.

(5) *Full payment.* Auction winners, except for small businesses eligible for installment payments, must pay the

balance of their winning bids in a lump sum within five (5) business days following the grant of their license(s). The grant of a license(s) to an auction winner(s) will be conditioned on the timely payment of all monies due the Commission. See 47 CFR 1.2109(a).

(6) *Withdrawal, default or disqualification.* See §§ 1.2104(g) and 1.2109 of this chapter.

(d) *Designated entities.* Designated entities are small businesses, and businesses owned by members of minority groups and/or women, as defined in 47 CFR 1.2110(b).

(1) *Bidding credits.* A winning bidder that qualifies as a business owned by women and/or minorities may use a bidding credit of twenty five (25) percent to lower the cost of its winning bid.

(2) *Installment payments.* Each licensee that qualifies as a small business may pay the remaining 80 percent of the net auction price in quarterly installment payments pursuant to § 1.2110(e) of this chapter. Licensees who qualify for installment payments are entitled to pay their winning bid amount in installments over the term of the license, with interest charges to be fixed at the time of licensing at a rate equal to the rate for five-year U.S. Treasury obligations. Payments shall include interest only for the first two years and payments of interest and principal amortized over the remaining three years of the license term. A license issued to an eligible small business that elects installment payments shall be conditioned on the full and timely performance of the license holder's quarterly payments.

(3) *Audits.* (i) Applicants and licensees claiming eligibility under this section shall be subject to audits by the Commission, using in-house and contract resources. Selection for audit may be random, on information, or on the basis of other factors.

(ii) Consent to such audits is part of the certification included in the short-form application (Form 175). Such consent shall include consent to the audit of the applicant's or licensee's books, documents, and other material (including accounting procedures and practices) regardless of form or type, sufficient to confirm that such applicant's

§ 95.816

47 CFR Ch. I (10–1–96 Edition)

or licensee's representations are, and remain, accurate. Such consent shall include inspection at all reasonable times of the facilities, or parts thereof, engaged in providing and transacting business, or keeping records regarding licensed IVDS and shall also include consent to the interview of principals, employees, customers and suppliers of the applicant or licensee.

(e) *Unjust enrichment.* Any business owned by minorities and/or women that obtains a IVDS license through the benefit of tax certificates shall not assign or transfer control of its license within one year of its license grant date. If the assignee or transferee is a business owned by minorities and/or women, this paragraph shall not apply; Provided, however, that the assignee or transferee shall not assign or transfer control of the license within one year of the grant date of the assignment or transfer.

[59 FR 24957, May 13, 1994, as amended at 61 FR 49075, Sept. 18, 1996]

EFFECTIVE DATE NOTE: At 61 FR 49075, Sept. 18, 1996, §95.816 was amended by revising paragraphs (c)(1), (c)(2), (c)(4), (c)(6), and (d)(1); removing paragraph (d)(2); redesignating paragraph (d)(3) as (d)(2) and revising it; and adding new paragraph (d)(3), effective Nov. 18, 1996. For the convenience of the user, the superseded text is set forth as follows:

§95.816 Competitive bidding proceedings.

\* \* \* \* \*

(c) \* \* \*

(1) *Competitive bidding design.* Sequential oral (oral outcry) auctions will be used to assign licenses in and around large urban areas and single-round sealed bidding will be used for rural areas unless otherwise specified by the Commission. See 47 CFR 1.2103 and 1.2104.

(2) *Forms.* (i) Applicants must submit short-form applications (FCC Form 175) as specified in Commission Public Notices. Minor deficiencies may be corrected prior to the auction. Major modifications such as changes in ownership, failure to sign an application or failure to submit required certifications will result in the dismissal of the application. See 47 CFR 1.2105(a) and (b).

(ii) Applicants must submit a long-form application (FCC Form 574) within ten (10) business days after being notified that it is

the winning bidder for a license. See 47 CFR 1.2107 (c) and (d).

\* \* \* \* \*

(4) *Down payments.* Within five (5) business days after an oral outcry auction is over, or within five (5) business days after being notified that it is the high bidder in a single round sealed bid auction, a high bidder on a particular license(s) must submit to the Commission's lockbox bank such additional funds as are necessary to bring total deposits (upfront payment plus down payment) up to twenty (20) percent of the high bid(s). Small businesses eligible and electing to use installment payments pursuant to §95.816(d)(3) are required to bring their total deposits up to ten (10) percent of their winning bid. The remainder of the twenty (20) percent down payment must be submitted within five (5) business days of the grant of their license(s). See 47 CFR 1.2107(b).

\* \* \* \* \*

(6) Default or disqualification, see 47 CFR 1.2104(g).

(i) *Sequential oral auctions.* If a high bidder, after signing a bid confirmation form, fails to make the required down payment, fails to pay for a license, or is otherwise disqualified, it will be assessed a penalty equal to the difference between its winning bid and the winning bid the next time the license is auctioned by the Commission, plus three (3) percent of the lower of these two amounts.

(ii) *Single round sealed bid auctions.* If a high bidder withdraws its bid prior to making the required down payment, it will be assessed a penalty equal to the difference between its bid and the next highest bid. If a high bidder, after having made the required down payment for a license, fails to pay the remaining amount for the license, or is otherwise disqualified, it will be assessed a penalty equal to the difference between its winning bid and the winning bid the next time the license is auctioned by the Commission plus three (3) percent of the lower of these two amounts.

(d) \* \* \*

(1) *Bidding credits.* A winning bidder that qualifies as a business owned by women and/or minorities may use a bidding credit of twenty-five (25) percent to lower the cost of its winning bid. A bidding credit is available for a license for either frequency segment A or frequency segment B in each service area. A bidding credit, however, may be applied to only one of the two licenses available in each service area.

(2) *Tax certificates.* Any initial investor in a business owned by minorities and/or women and who provides "start-up" financing, which allows such business to acquire a

IVDS license(s), and any investor who purchases ownership in an interest in a IVDS license owned by minorities and/or women within the first year after license issuance, which allows for the stabilization of the entity's capital base, may, upon the sale of such investment or interest, request from the Commission a tax certificate, so long as such investor transaction does not reduce minority or female ownership or control in the entity below 50.1 percent. Any IVDS licensee who assigns or transfers control of its license to a business owned by minorities and/or women may request that the Commission issue it a tax certificate.

(3) *Installment payments.* Small businesses, including small businesses owned by women and/or minorities may elect to pay the full amount of their bid in installments over the term of their licenses. See 47 CFR 1.2110(d).

\* \* \* \* \*

#### **§95.817 Application for renewal of license.**

(a) Each application for renewal of an IVDS system license and for renewal of each individually licensed CTS shall be submitted on a Commission-generated FCC Form 574-R when the licensee has received that form in the mail from the Commission. If the licensee has not received the Form 574-R within sixty days of expiration, application for renewal shall be submitted on FCC Form 405-A.

(b) Each application for renewal must be submitted as part of a renewal package to the address set forth in §1.1102 of the Commission's Rules.

(c) The renewal package must include a cover sheet specifying the licensee's name and address and the service area number and name.

#### **§95.819 License transferability.**

(a) IVDS system licenses acquired through competitive bidding procedures may be transferred, assigned, sold, or given away only in accordance with the provisions and procedures set forth in 47 CFR 1.2111.

(b) Except for licenses acquired through competitive bidding procedures, the licensees may not transfer, assign, sell, or give the IVDS system licenses or any component CTS licenses to any other entity until the five year construction benchmark (50 percent coverage) has been met.

(c) Once the five year construction benchmark has been met, licensees of IVDS systems that were not acquired through competitive bidding may transfer, sell, assign, or give the IVDS system licenses together with all of its component CTS licenses to any other entity in accordance with the provisions of §95.821. If the licensee sells or gives away the apparatus the new owner must obtain a new IVDS system license and CTS licenses before placing it in operation.

[59 FR 24958, May 13, 1994]

#### **§95.821 Application for transfer of control.**

If an IVDS system licensee agrees to a change in control of the station, the holder must request Commission consent for change of control by filing a Form 703. The licensee shall mail the request, together with the filing fee, to the address specified in §1.1102 of this chapter. The document granting such consent must be kept as part of the IVDS system authorization. An applicant for voluntary transfer of control or assignment under this section where the subject license was acquired by the transferor or assignor through a system of random selection shall, together with its application for transfer of control or assignment, file with the Commission the associated contracts for sale, option agreements, management agreements, or other documents disclosing the total consideration that the applicant would receive in return for the transfer or assignment of its license. This information should include not only a monetary purchase price, but also any future, contingent, in-kind, or other consideration (e.g., management or consulting contracts either with or without an option to purchase; below-market financing).

[48 FR 35237, Aug. 3, 1983, as amended at 59 FR 9102, Feb. 25, 1994]

#### SYSTEM REQUIREMENTS

#### **§95.831 Service requirements.**

Subject to the initial construction requirements of Section 95.833, each IVDS system licensee must make the service available to at least 50 percent

**§ 95.833**

of the population or land area located within the service area.

[61 FR 1288, Jan. 19, 1996]

**§ 95.833 Construction requirements.**

(a) Each IVDS system licensee must make the service available to at least 30 percent of the population or land area within the service area within three years of grant of the IVDS system license, and 50 percent of the population or land area within five years of grant of the IVDS system license. Failure to do so will cancel the IVDS system license automatically. For the purposes of this section, a CTS is not considered as providing service unless that CTS and two associated RTUs are placed in operation.

(b) Each IVDS system licensee must file a progress report at the conclusion of each of the two benchmark periods to inform the Commission of the construction status of the system. The report must be addressed to: Federal Communications Commission, Wireless Telecommunications Bureau, Special Services Branch, 1270 Fairfield Road, Gettysburg, PA 17325-7245. The report must include:

- (1) A showing of how the system meets the benchmark; and
- (2) A list, including addresses, of all component CTSs constructed.

[61 FR 1288, Jan. 19, 1996]

**§ 95.835 Station identification.**

No RTU or CTS is required to transmit a station identification announcement.

**§ 95.837 Station inspection.**

Upon request by an authorized Commission representative, the IVDS system licensee must make any component CTS available for inspection.

**§ 95.839 Operation in the National Radio Quiet Zone.**

(a) Before constructing a CTS in any area within the National Radio Quiet Zone (see § 95.41) or before changing frequency segment, transmitter power, antenna height or directivity, or the coverage area of an existing CTS or RTU located within any area within the National Radio Quiet Zone, the licensee must give written notification

**47 CFR Ch. I (10-1-96 Edition)**

thereof to the Interference Office, National Radio Astronomy Observatory, P.O. Box 2, Green Bank, WV 24944.

(b) The notification must include the geographical coordinates of all component CTS antennas, antenna ground elevation above mean sea level, antenna center of radiation above ground level, antenna directivity, proposed frequency, type of emission, and transmitter power.

(c) If an objection to the proposed CTS is received by the Commission from the National Radio Astronomy Observatory at Green Bank, Pocahontas County, WV, for itself or on behalf of the Naval Research Laboratory at Sugar Grove Pendleton County, WV, within 20 days from the date of notification, the Commission will consider all aspects of the problem and take whatever action is deemed appropriate.

**§ 95.841 Operation near a Commission monitoring facility.**

Each CTS and each RTU transmitting from a location within 1.6 km (1 mile) of a Commission monitoring facility must protect that facility from harmful interference. Failure to do so could result in imposition of restrictions upon the operation of the CTS or RTU by the Engineer-in-Charge of the facility. (Geographical coordinates of the facilities that require protection are listed in § 0.121(c) of this chapter.)

**TECHNICAL STANDARDS**

**§ 95.851 Type acceptance.**

Each CTS and RTU transmitter must be typed-accepted for use in the IVDS in accordance with subpart J of part 2 of this chapter.

**§ 95.853 Frequency segments.**

(a) Frequency segment A is 218.0-218.500 MHz. Frequency segment B is 218.501-219.0 MHz.

(b) Each CTS and each RTU in the same IVDS system shall transmit in the same assigned frequency segment.

**§ 95.855 Transmitter effective radiated power limitation.**

(a) The effective radiated power (ERP) of each CTS and RTU shall be limited to the minimum necessary for successful communications. RTUs with

powers in excess of 100 milliwatts must incorporate automatic power control to ensure the minimum ERP is used. No CTS may transmit with an ERP exceeding 20 watts. No fixed RTU may transmit with an ERP exceeding 20 watts. No mobile RTU may transmit with an ERP exceeding 100 milliwatts mean power.

(b) For an IVDS system located in a TV Channel 13 station Grade B predicted contour, the maximum ERP shall be limited as follows:

TV channel 13 service area	Maximum CTS ERP (watts)
City Grade .....	20
Grade A .....	7
Grade B .....	1
Grade B +2 miles .....	1
Grade B +3 miles .....	3
Grade B +4 miles .....	10
Grade B +5 miles and beyond .....	20

[57 FR 8275, Mar. 9, 1992, as amended at 61 FR 32711, June 25, 1996]

**§95.857 Emission standards.**

(a) All transmissions by each CTS and by each RTU shall use an emission type that complies with the following standard for unnecessary radiation.

(b) All spurious and out-of-band emissions shall be attenuated:

(1) Zero dB on any frequency within the authorized frequency segment.

(2) At least 28 dB on any frequency removed from the midpoint of the assigned frequency segment by more than 250 kHz up to and including 750 kHz;

(3) At least 35 dB on any frequency removed from the midpoint of the assigned frequency segment by more than 750 kHz up to and including 1250 kHz;

(4) At least 43 plus 10 log (base 10) (mean power in watts) dB on any frequency removed from the midpoint of the assigned frequency segment by more than 1250 kHz.

HAAT		Maximum ERP (watts)
(m)	(feet)	
0-152.4 .....	0-500 .....	20.0
152.5-304.8 .....	501-1000 .....	5.0
304.9-609.6 .....	1001-2000 .....	1.2

(c) When testing for type acceptance, all measurements of unnecessary radiation are performed using a carrier frequency as close to the edge of the authorized frequency segment as the transmitter is designed to be capable of operating.

(d) The resolution bandwidth of the instrumentation used to measure the emission power shall be 100 Hz for measuring emissions up to and including 250 kHz from the edge of the authorized frequency segment, and 10 kHz for measuring emissions more than 250 kHz from the edge of the authorized frequency segment. If a video filter is used, its bandwidth shall not be less than the resolution bandwidth. The power level of the highest emission within the frequency segment, to which the attenuation is referenced, shall be remeasured for each change in resolution bandwidth.

**§95.859 Antennas.**

(a) The CTS antenna includes the radiating element(s), tower, supports and all appurtenances. No CTS antenna shall be elevated higher than necessary to assure adequate service.

(1) A CTS antenna located within a boundary line 16 km (10 miles) outside the Grade B contour of a TV Channel 13 station may not exceed a maximum Height Above Average Terrain (HAAT), as defined in §90.309, and maximum ERP as set forth below:

HAAT		Maximum ERP (watts)
(m)	(feet)	
0-36.6 .....	0-120 .....	20.0
36.6-73.2 .....	121-240 .....	5.0
73.3-152.4 .....	241-500 .....	1.2
152.5-304.8 .....	501-1000 .....	0.29
304.9-609.6 .....	1001-2000 .....	0.073

(2) A CTS antenna located beyond a boundary line 16 km (10 miles) outside the Grade B contour of a TV Channel 13 station may not exceed a maximum HAAT, as defined in §90.309, and maximum ERP as set forth below:

(b) No CTS antenna shall be located within 61 m (200 feet) of a residential dwelling unless the IVDS system licensee has reduced power such that the field strength of the CTS antenna at the residential dwelling does not increase relative to the field strength of the CTS antenna at 61 m or obtained the written concurrence of the resident(s) within 61 m of the CTS antenna. The written concurrence must be kept as part of the IVDS system authorization.

(c) The RTU may be connected to an external antenna not more than 6.1 m (20 feet) above ground or above an existing man-made structure (other than an antenna structure). Connectors that are used to connect RTUs to an external antenna shall not be of the types generally known as “F-type” or “BNC type.” Use of an external antenna is subject to §95.861.

[57 FR 36373, Aug. 13, 1992]

**§95.861 Interference.**

(a) When an IVDS system suffers harmful interference within its service area from or causes harmful interference to another IVDS system, the licensees of both systems must cooperate and resolve the problem by mutually satisfactory arrangements. If the licensees are unable to do so, the Commission may impose restrictions including, but not limited to, specifying the transmitter power, antenna height, or area or hours of operation of the stations concerned.

(b) The use of any frequency segment at a given geographical location may be denied when, in the judgment of the Commission, its use in that location is not in the public interest; the use of a frequency segment specified for the IVDS system may be restricted as to specified geographical areas, maximum power, or other operating conditions.

(c) Unless the IVDS system licensee obtains written consent from the TV Channel 13 station licensee to dispense with this notification, each IVDS system licensee must notify all households located both within a TV Channel 13 station Grade B predicted contour and the IVDS system service area of the potential for interference from an IVDS system. The IVDS system licensee must also inform those poten-

tially affected households that it will eliminate any objectionable interference to television reception caused by its IVDS system. This notification shall be made no earlier than two weeks before and no later than two weeks after initiation of IVDS in the TV Channel 13 station Grade B predicted contour. The written consent must be kept as part of the IVDS system authorization.

(d) Each IVDS system licensee must provide upon request, and install free of charge, an interference reduction device to any household within a TV Channel 13 station Grade B predicted contour that experiences interference due to a component CTS or RTU.

(e) Each IVDS system licensee must investigate and eliminate interference to television broadcasting and reception, from its component CTSs and RTUs, within 30 days of the time it is notified in writing, by either an affected television station, an affected viewer, or the Commission, of an interference complaint. Should the licensee fail to eliminate the interference within the 30 day period, the CTS or RTU causing the interference must discontinue operation.

(f) The boundaries for each IVDS service area, as defined in §95.803, are the limit of interference protection for an IVDS system.

[57 FR 8275, Mar. 9, 1992, as amended at 57 FR 36374, Aug. 13, 1992]

**§95.863 Duty cycle.**

(a) Except as provided in paragraph (b) of this section, the maximum duty cycle of each RTU, either fixed or mobile, shall not exceed 5 seconds-per-hour, or, alternatively, not exceed one percent within any 100 millisecond interval.

(b) The duty cycle limitation specified above for RTUs does not apply in the following situations:

(1) To fixed and mobile RTUs when there is no TV channel 13 predicted Grade B contour overlap in the licensed service area; or

(2) To fixed RTUs in areas where there is Grade B contour overlap and the RTU is located outside the TV

channel 13 predicted Grade B contour but within the licensed service area.

[61 FR 32711, June 25, 1996]

### Subpart G—Low Power Radio Service (LPRS)

SOURCE: 61 FR 46569, Sept. 4, 1996, unless otherwise noted.

EFFECTIVE DATE NOTE: At 61 FR 46569, Sept. 4, 1996, subpart G, consisting of §§95.1001—95.1019, was added to part 95, effective Oct. 4, 1996.

#### GENERAL PROVISIONS

##### §95.1001 Eligibility.

An entity is authorized by rule to operate a LPRS transmitter and is not required to be individually licensed by the FCC if it is not a representative of a foreign government and if it uses the transmitter only in accordance with §95.1009. Each entity operating a LPRS transmitter for AMTS purposes must hold an AMTS license under part 80 of this chapter.

##### §95.1003 Authorized locations.

LPRS operation is authorized:

- (a) Anywhere CB station operation is permitted under §95.405(a); and
- (b) Aboard any vessel or aircraft of the United States, with the permission of the captain, while the vessel or aircraft is either travelling domestically or in international waters or airspace.

##### §95.1005 Station identification.

An LPRS station is not required to transmit a station identification announcement.

##### §95.1007 Station inspection.

All LPRS system apparatus must be made available for inspection upon request by an authorized FCC representative.

##### §95.1009 Permissible communications.

LPRS stations may transmit voice, data, or tracking signals as permitted in this section. Two-way voice communications are prohibited.

- (a) Auditory assistance communications (including but not limited to applications such as assistive listening devices, audio description for the blind,

and simultaneous language translation) for:

- (1) Persons with disabilities. In the context of the LPRS, the term “disability” has the meaning given to it by section 3(2)(A) of the Americans with Disabilities Act of 1990 (42 U.S.C. 12102(2)(A)), *i.e.*, persons with a physical or mental impairment that substantially limits one or more of the major life activities of such individuals;

- (2) Persons who require language translation; or

- (3) Persons who may otherwise benefit from auditory assistance communications in educational settings.

- (b) Health care related communications for the ill.

- (c) Law enforcement tracking signals (for homing or interrogation) including the tracking of persons or stolen goods under authority or agreement with a law enforcement agency (federal, state, or local) having jurisdiction in the area where the transmitters are placed.

- (d) AMTS point-to-point network control communications.

##### §95.1011 Channel use policy.

- (a) The channels authorized to LPRS systems by this part are available on a shared basis only and will not be assigned for the exclusive use of any entity.

- (b) Those using LPRS transmitters must cooperate in the selection and use of channels in order to reduce interference and make the most effective use of the authorized facilities. Channels must be selected in an effort to avoid interference to other LPRS transmissions.

- (c) Operation is subject to the conditions that no harmful interference is caused to the United States Navy’s SPASUR radar system (216.88–217.08 MHz) or to TV reception within the Grade B contour of any TV channel 13 station or within the 68 dBu predicted contour of any low power TV or TV translator station operating on channel 13.

##### §95.1013 Antennas.

- (a) The maximum allowable ERP for a station in the LPRS is 100 mW.

- (b) AMTS stations must employ directional antennas.

(c) Antennas used with LPRS units must comply with the following:

(1) For LPRS units operating entirely within an enclosed structure, e.g., a building, there is no limit on antenna height;

(2) For LPRS units not operating entirely within an enclosed structure, the tip of the antenna shall not exceed 30.5 meters (100 feet) above ground. In cases where harmful interference occurs the FCC may require that the antenna height be reduced; and

(3) The height limitation in paragraph (c)(2) of this section does not apply to LPRS units in which the antenna is an integral part of the unit.

**§95.1015 Disclosure policies.**

(a) Manufacturers of LPRS transmitters used for auditory assistance, health care assistance, and law enforcement tracking purposes must include with each transmitting device the following statement: “This transmitter is authorized by rule under the Low Power Radio Service (47 C.F.R. Part 95) and must not cause harmful interference to TV reception or United States Navy SPASUR installations. You do not need an FCC license to operate this transmitter. This transmitter may only be used to provide: auditory assistance to persons with disabilities, persons who require language translation, or persons in educational settings; health care services to the ill; law enforcement tracking services under agreement with a law enforcement agency; or automated maritime telecommunications system (AMTS) network control communications. Two-way voice communications and all other types of uses not mentioned above are expressly prohibited.”

(b) Prior to operating a LPRS transmitter for AMTS purposes, an AMTS licensee must notify, in writing, each television station that may be affected by such operations, as defined in §80.215(h) of this chapter. The notification provided with the station’s license application is sufficient to satisfy this requirement if no new television stations would be affected.

**§95.1017 Labeling requirements.**

(a) Each LPRS transmitting device shall bear the following statement in a

conspicuous location on the device: “This device may not interfere with TV reception or federal government radar, and must accept any interference received, including interference that may cause undesired operation.”

(b) Where an LPRS device is constructed in two or more sections connected by wires and marketed together, the statement specified in this section is required to be affixed only to the main control unit.

(c) When the LPRS device is so small or for such use that it is not practicable to place the statement specified in the section on it, the statement must be placed in a prominent location in the instruction manual or pamphlet supplied to the user or, alternatively, shall be placed on the container in which the device is marketed.

**§95.1019 Marketing limitations.**

Transmitters intended for operation in the LPRS may be marketed and sold only for those uses described in §95.1109.

**PART 97—AMATEUR RADIO SERVICE**

**Subpart A—General Provisions**

- Sec.
- 97.1 Basis and purpose.
- 97.3 Definitions.
- 97.5 Station license required.
- 97.7 Control operator required.
- 97.9 Operator license.
- 97.11 Stations aboard ships or aircraft.
- 97.13 Restrictions on station location.
- 97.15 Station antenna structures.
- 97.17 Application for new license or reciprocal permit for alien amateur licensee.
- 97.19 Application for a vanity call sign.
- 97.21 Application for a modified or renewed license.
- 97.23 Mailing address.
- 97.25 License term.
- 97.27 FCC modification of station license.
- 97.29 Replacement license document.

**Subpart B—Station Operation Standards**

- 97.101 General standards.
- 97.103 Station licensee responsibilities.
- 97.105 Control operator duties.
- 97.107 Alien control operator privileges.
- 97.109 Station control.
- 97.111 Authorized transmissions.
- 97.113 Prohibited transmissions.
- 97.115 Third party communications.
- 97.117 International communications.