

NRMRL-RTP-236a
January 2002

Characterization of Mercury Emissions at a Chlor-Alkali Plant

VOLUME I Report and Appendices A-E

John S. Kinsey
U.S. Environmental Protection Agency
Office of Research and Development
National Risk Management Research Laboratory
Research Triangle Park, North Carolina 27711

ABSTRACT

Current estimates indicate that up to 160 short tons (146 Mg) of mercury (Hg) is consumed by the chlor-alkali industry each year. Very little quantitative information is currently available, however, on the actual Hg losses from these facilities. The Hg cell building roof vent is considered to be the most significant potential emission point in chlor-alkali plants, especially when the cells are opened for maintenance. Because of their potential importance, chlor-alkali plants have been identified as needing more accurate measurements of Hg emissions. To obtain a better understanding of the fate of Hg within their manufacturing process, the Olin Corporation voluntarily agreed to cooperate with the U.S. Environmental Protection Agency in a comprehensive study of the Hg emissions from their Augusta, GA, facility, in collaboration with other members of the Chlorine Institute representing the active chlor-alkali plants in the United States.

To investigate the Hg releases from the Olin chlor-alkali facility, the EPA's National Risk Management Research Laboratory, Air Pollution Prevention and Control Division (EPA-APPD) in Research Triangle Park, NC, organized a special study involving multiple organizations and personnel. However, only the research conducted by EPA-APPD involving roof vent monitoring and air flow studies conducted in the Olin cell building is discussed in this report.

The overall objective of monitoring the cell building roof vent was to determine the total elemental mercury (Hg^0) mass flux from the cell building under a range of typical wintertime meteorological conditions, including both normal operation of the cell building and routine maintenance of Hg cells and decomposers. Secondary objectives of the research were to perform an air flow mass balance for the building and to compare various Hg monitoring methods under a variety of sampling conditions. Both objectives were met during the February 2000 field sampling campaign, which showed an average Hg^0 emission rate of 0.36 g/min from the roof ventilator as determined over the 9-day monitoring period.

TABLE OF CONTENTS

Volume I

ABSTRACT	ii
LIST OF FIGURES	vi
LIST OF TABLES	viii
LIST OF ABBREVIATIONS AND SYMBOLS	ix
UNIT CONVERSION TABLE	xi
ACKNOWLEDGMENTS	xii
SECTION 1 INTRODUCTION	1
1.1 Background	1
1.2 Overall Program Description	2
1.2.1 Preliminary Survey	4
1.2.2 Winter Sampling Campaign	5
1.3 Research Objectives	8
1.4 Organization of Report	8
SECTION 2 CONCLUSIONS AND RECOMMENDATIONS	9
SECTION 3 PROCESS DESCRIPTION AND OPERATION	12
3.1 General Process Description	12
3.2 Plant Operation	12
3.3 Cell Building	15
SECTION 4 EXPERIMENTAL PROCEDURES	24
4.1 Measurement Methods, Setup, and Calibration	24
4.1.1 Roof Vent Monitoring	24
4.1.2 Manual Tracer Gas Analyses	29
4.1.3 Manual Velocity Measurements	31
4.2 Data Reduction and Analysis	32
4.2.1 Roof Vent Monitoring	32
4.2.2 Tracer Gas Analyses	33
4.2.3 Emission Rate Calculations	35
4.2.4 Manual Velocity Measurements and Flow Balance Calculations	40

TABLE OF CONTENTS (Continued)

SECTION 5	RESULTS AND DISCUSSION	44
5.1	Mercury Monitoring Results	44
5.1.1	Monitoring Data and Mercury Emission Rates	44
5.1.2	Comparison of Mercury Measurement Methods	55
5.2	Tracer Gas Results	63
5.2.1	Roof Vent Monitoring	63
5.2.2	Tracer Gas Study – Manual Bag Sampling	63
5.3	Air Flow Study Results	66
5.3.1	Roof Vent Monitoring	66
5.3.2	Flow Balance Calculations	68
5.4	Discussion of Results	69
5.4.1	Roof Vent Monitoring	69
5.4.2	Building Air Flow Evaluation	70
5.4.3	Comparison with Historical Information	71
SECTION 6	QUALITY ASSURANCE/QUALITY CONTROL	74
6.1	UV-DOAS Measurements	74
6.2	Optical Anemometry	74
6.3	SF ₆ Release, Sampling, and Analysis (FTIR)	76
6.4	Long-Path FTIR QA/QC Checks (Roof Vent)	77
6.5	On-Site Audit	79
6.6	Data Quality Indicators	80
SECTION 7	REFERENCES	81
APPENDICES		
A	Description of Buildings and Processes at the Olin Facility	A-i
B	FTIR Spectral Analyses Conducted by ManTech, Inc. (Jeff Childers)	B-i
C	FTIR Spectral Analyses Conducted by ARCADIS Geraghty & Miller (David Natschke)	C-i
D	Roof Vent Manual Velocity Data	D-i
E	Manual Velocity Data in Cell Building Openings and Associated Air Flow Balance Calculations	E-i

TABLE OF CONTENTS (Continued)

Volume II

F	Elemental Mercury Emission Rate Calculations	F-i
G	Elemental Mercury and Air Velocity Measurements at Entrance to Roof Vent Made During January 2000 Presurvey	G-i
H	UV-DOAS Quality Control Data	H-i
I	Bag Sampling Quality Control Data and Rotameter Calibrations	I-i
J	Copies of Field Sampling Notebook Pages from Manual Bag Sampling	J-i

LIST OF FIGURES

1-1	Project organization chart (includes contractor support from OPSIS [®] , Inc., and Eastern Research Group, Inc.).	3
1-2	Location of measurement activities.	6
3-1	Simplified diagram of the mercury cell process.	13
3-2	Process flow diagram for Olin-Augusta.	14
3-3a	Cell building showing interior of roof ventilator.	16
3-3b	Cell building showing exterior of roof ventilator (from north).	17
3-4	Electrolyzer used at the Olin-Augusta plant.	18
3-5	Mercury cell: horizontal view and outlet end-box view.	19
3-6	North line of electrolytic cells in Olin cell building.	20
3-7	Decomposer used at the Olin-Augusta plant.	21
3-8	General diagram of the cell building showing cell rows, general fan locations, etc.	23
4-1	Cross-section of roof ventilator showing internal structure.	26
4-2	From left to right, the FTIR retroreflector, UV-DOAS light source, and optical anemometer receiver unit installed on the east sampling platform.	27
4-3	Relative locations of instrument beam paths in roof vent cross section.	29
4-4	Cylinder layout along the cell building basement.	34
4-5	Soaker tubing layout inside the cell room.	34
4-6a	Average roof vent temperature differential as determined from 15-min monitoring data.	39
4-6b	Calculated temperature differential for roof ventilator as determined from average monitoring data shown in Figure 4-6a.	39
5-1	Time history of roof vent elemental mercury concentration for February 17, 2000.	45
5-2	Time history of roof vent elemental mercury concentration for February 18, 2000.	45
5-3	Time history of roof vent elemental mercury concentration for February 19, 2000.	46
5-4	Time history of roof vent elemental mercury concentration for February 20, 2000.	46
5-5	Time history of roof vent elemental mercury concentration for February 21, 2000.	47
5-6	Time history of roof vent elemental mercury concentration for February 22, 2000.	47
5-7	Time history of roof vent elemental mercury concentration for February 23, 2000.	48
5-8	Time history of roof vent elemental mercury concentration for February 24, 2000.	48
5-9	Time history of roof vent elemental mercury concentration for February 25, 2000.	49
5-10	Time history of roof vent air velocity for February 17, 2000.	50
5-11	Time history of roof vent air velocity for February 18, 2000.	50
5-12	Time history of roof vent air velocity for February 19, 2000.	51
5-13	Time history of roof vent air velocity for February 20, 2000.	51
5-14	Time history of roof vent air velocity for February 21, 2000.	52

LIST OF FIGURES (Continued)

5-15	Time history of roof vent air velocity for February 22, 2000.	52
5-16	Time history of roof vent air velocity for February 23, 2000.	53
5-17	Time history of roof vent air velocity for February 24, 2000.	53
5-18	Time history of roof vent air velocity for February 25, 2000.	54
5-19	Elemental mercury emission rates for February 17, 2000.	56
5-20	Elemental mercury emission rates for February 18, 2000.	56
5-21	Elemental mercury emission rates for February 19, 2000.	57
5-22	Elemental mercury emission rates for February 20, 2000.	57
5-23	Elemental mercury emission rates for February 21, 2000.	58
5-24	Elemental mercury emission rates for February 22, 2000.	58
5-25	Elemental mercury emission rates for February 23, 2000.	59
5-26	Elemental mercury emission rates for February 24, 2000.	59
5-27	Elemental mercury emission rates for February 25, 2000.	60
5-28	Lateral profile of elemental mercury concentration as determined by the Jerome 431-X instrument.	61
5-29	UV-DOAS/Tekran comparison (February 17-21, 2000).	62
5-30	Chronology of elemental mercury concentrations measured by OPSIS™ Model AR 500 UV-DOAS and Tekran Model 2537A CVAFS for February 17-21, 2000.	62
5-31	Bag sampling locations in cell building.	64
5-32	Hand-held anemometer readings at the optical anemometer measurement height on the east sampling platform, looking west	67
5-33	Hand-held anemometer readings at the optical anemometer measurement height on the west sampling platform, looking west.	67
5-34	Profile of elemental mercury concentration along length of roof vent entrance as obtained during the January 2000, presurvey.	70

LIST OF TABLES

4-1	Roof Vent Instrumentation	25
4-2	Typical FTIR Operating Parameters	31
4-3	Gas Release Concentrations	36
5-1	Summary of 30-sec Roof Vent DOAS Data	49
5-2	Summary of 1-min Roof Vent Optical Anemometer Data	54
5-3	Summary of Calculated Elemental Mercury Emission Rates	60
5-4	Manual Bag Analysis Results	64
5-5	Comparison of Velocity Measurements in Roof Vent	68
5-6	Results of Air Flow Balance Calculations for the Olin Cell Building	68
5-7	Comparison of Current Study with Prior Research	72
6-1	QC Checks for Experimental Methods Included in QA Plan	75
6-2	Quality Control Checks for UV-DOAS	75
6-3	Results of Daily QC Checks of Model 104a Optical Anemometer	76
6-4	Manual Bag Sampling/Analysis Blank Control Checks	78
6-5	Manual Bag Sampling/Analysis Quality Control Checks	78
6-6	Data Quality Indicator Results	80

LIST OF ABBREVIATIONS AND SYMBOLS

APPCD	Air Pollution Prevention and Control Division
ATREEs	anemometer trees
CAPs	Chlor-alkali plants
CH ₄	methane
Cl ₂	chlorine gas
CO	carbon monoxide
CVAFS	cold-vapor atomic fluorescence spectrometer
DAS	data acquisition system
DMB	direct mass balance
DOAS	differential optical absorption spectrometer
DQI	data quality indicator
EPA	U.S. Environmental Protection Agency
ERG	Eastern Research Group, Inc.
FTIR	Fourier transform infrared spectrometer
H ₂	hydrogen
HCl	hydrogen chloride
Hg	mercury
Hg ⁰	elemental mercury
LIDAR	Light Detection and Ranging
LOA	Scientific Technology Model LOA-104 optical anemometer
LRPCD	Land Remediation and Pollution Control Division
N ₂ O	nitrous oxide
NaCl	sodium chloride

LIST OF ABBREVIATIONS AND SYMBOLS (Continued)

NaOH	sodium hydroxide
NERL	National Exposure Research Laboratory
NIST	National Institute for Standards and Technology
NWS	National Weather Service
OECA	Office of Enforcement and Compliance Assurance
ORNL	Oak Ridge National Laboratory
OxyChem	Occidental Chemical Corporation
PI	Principal Investigator
QAPjP	Quality Assurance Project Plan
QC	quality control
SOP	Standard Operating Procedure
SF ₆	sulfur hexafluoride
UM	University of Michigan
UV-DOAS	ultraviolet differential optical absorption spectrometer

UNIT CONVERSION TABLE

Multiply	By	To Obtain
atm	29.92	in. Hg
atm	760	mm Hg
ft	0.3048	m
km	0.6214	mi
L/day	0.264	gal./day
m ³ /min	35.31	ft ³ /min
pounds	453.6	g
short ton	0.91	metric ton
temperature (°C + 17.8)	1.8	temperature (°F)

ACKNOWLEDGMENTS

This report was prepared with the assistance of Julie Swift and Joan Bursey of Eastern Research Group, Inc., 1600 Perimeter Park Drive, Morrisville, NC 27560, under EPA Contract 68-D7-0001. Julie Swift was responsible for the tracer gas release and manual bag sampling conducted in the field as well as preparing applicable sections of the report. Joan Bursey was responsible for the QA/QC sections of the report as well as supervising its overall production. The author acknowledges the excellent contributions of both individuals.

SECTION 1

INTRODUCTION

1.1 Background

Current estimates indicate that up to 160 short tons (146 Mg) of mercury (Hg) is consumed by the chlor-alkali industry each year (Chlorine Institute, 1999). Very little quantitative information is currently available, however, on the actual Hg losses from these facilities. The most significant potential emission point in chlor-alkali plants (CAPs) is thought to be the mercury cell building roof vent, especially when the cells are opened for maintenance. Because of their potential importance, CAPs have been identified as needing more accurate measurements of Hg emissions.

In order to better understand the fate of mercury within their manufacturing process, the Olin Corporation voluntarily agreed to cooperate with the U.S. Environmental Protection Agency (EPA) in a comprehensive study of the Hg emissions from their Augusta, GA, facility. This effort is in collaboration with other members of the Chlorine Institute representing the active chlor-alkali plants in the United States. Chlorine Institute members have committed to reduce overall mercury consumption by 50% (from 1990-95 levels) by the year 2005.

To investigate the Hg releases from the Olin chlor-alkali facility, the U. S. Environmental Protection Agency's National Risk Management Research Laboratory, Air Pollution Prevention and Control Division (EPA-APPCCD) in Research Triangle Park, NC, organized a special study involving multiple organizations and personnel. Each major aspect of the study was addressed by a separate Principal Investigator (PI) based on the individual area of expertise. It should be noted, however, that only the research conducted by EPA-APPCCD involving roof vent monitoring and air flow studies conducted in the Olin cell building is discussed in this report. The following sections describe the overall study

conducted at the Augusta plant, the objectives of the specific research described in this report, and organization of the remainder of the document.

1.2 Overall Program Description

A multidisciplinary research team was assembled for the purpose of the Olin study. This team was made up of the following organizations and associated principal investigators (PIs):

- Olin Corporation, Olin Chemicals, Charleston, TN (**W. Rankin**) and Chlor-Alkali Division, Augusta, GA (**S. Asbill**).
- U.S. Department of Energy, Oak Ridge National Laboratory (ORNL), Environmental Sciences Division, Oak Ridge, TN (**S. Lindberg**).
- U.S. Environmental Protection Agency, Office of Enforcement and Compliance Assurance (EPA-OECA), Office of Regulatory Enforcement, Washington, DC. (**C. Secret**).
- U.S. Environmental Protection Agency, Office of Research and Development, National Exposure Research Laboratory (EPA-NERL), Research Triangle Park, NC (**M. Landis**).
- U.S. Environmental Protection Agency, Office of Research and Development, National Risk Management Research Laboratory, Air Pollution Prevention and Control Division (EPA-APPCD), Research Triangle Park, NC (**J. Kinsey**).
- U.S. Environmental Protection Agency, Office of Research and Development, National Risk Management Research Laboratory, Land Remediation and Pollution Control Division (EPA-LRPCD), Cincinnati, OH (**P. Randall**).
- U.S. Environmental Protection Agency, Region 4 (EPA-Region 4), Science and Ecosystem Support Division, Atlanta, GA (**D. France**).
- U.S. Environmental Protection Agency, Region 5 (EPA-Region 5), Great Lakes Program Office, Chicago, IL (**F. Anscombe**).
- University of Michigan (UM), Department of Environmental & Industrial Health, School of Public Health, Ann Arbor, MI (**J. Nriagu**).

As shown, the research team represents nine different organizations with up to 28 people working on-site. Figure 1-1 shows the organization of the project, including the various monitoring activities conducted and PIs responsible for each facet of the program as well as contractor support to EPA-APPCD from OPSIS[®], Inc. and Eastern Research Group (ERG), Inc.

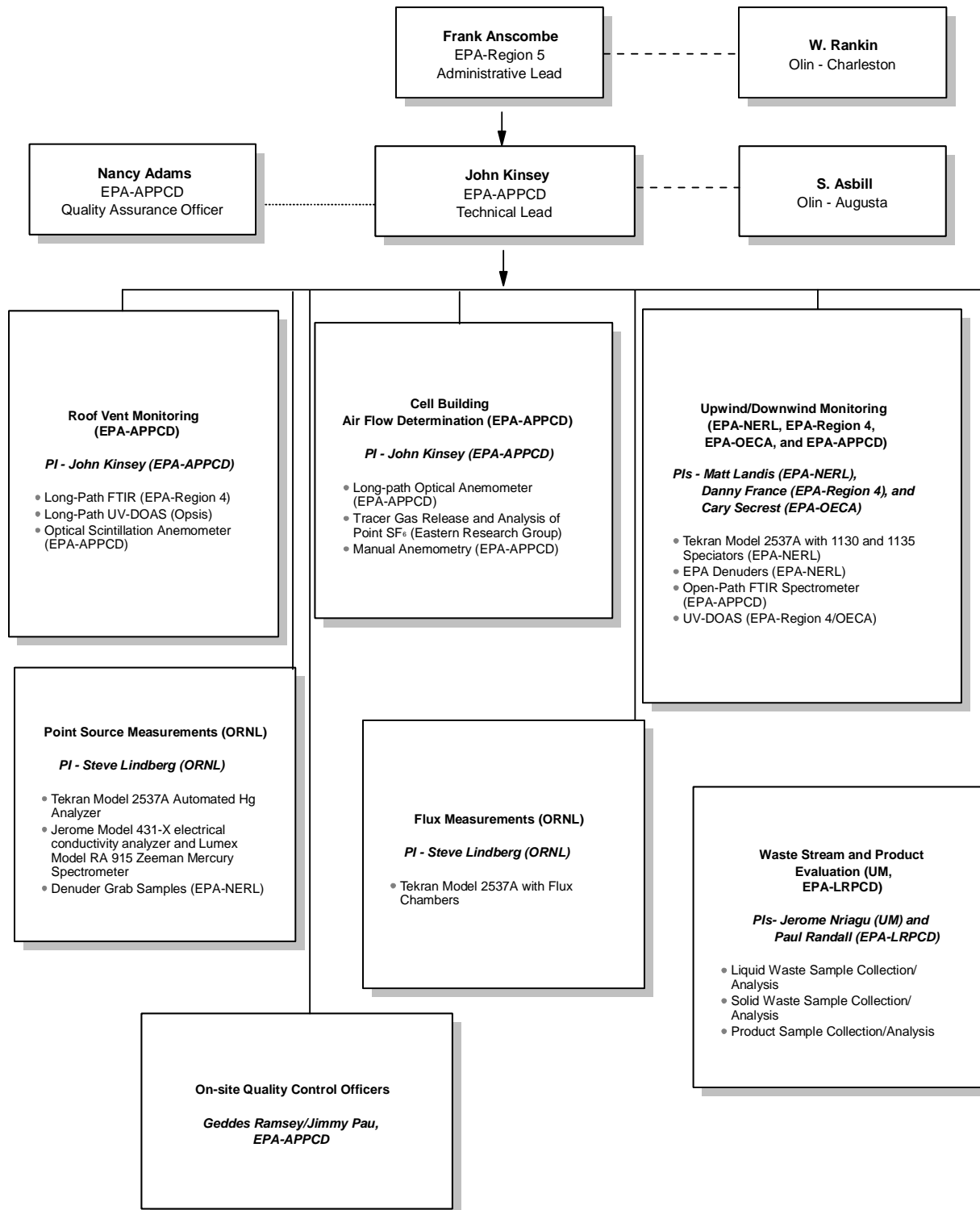

Figure 1-1. Project organization chart (includes contractor support from OPSIS[®], Inc., and Eastern Research Group, Inc.).

The program was divided into two phases: a preliminary survey, and a winter sampling campaign conducted in February 2000. A summer campaign was also planned to evaluate the effects of elevated ambient temperature but this phase was eliminated and thus is not discussed here. Implementation of the overall program is briefly outlined below with formal publication of the results by the respective Principal Investigator planned for late-2002.

1.2.1 Preliminary Survey

The purpose of the survey was to obtain preliminary information to assist in planning the second, and more significant, phase of the program. The survey included measurements of the typical range of elemental mercury (Hg^0) concentrations in the cell building as well as similar measurements external to the cell building. In addition, flow visualization experiments were also performed and meetings held with Olin operating personnel to plan the logistics of the winter sampling campaign.

The Hg monitoring methods used in the preliminary survey generally involved portable hand-held instruments, including both the Jerome Model 431-X electrical conductivity analyzer and the Lumex Model RA-915 Zeeman Mercury Spectrometer. The Model RA-915 is a portable cold-vapor atomic absorption (CVAA) spectrometer capable of monitoring Hg^0 at nanograms per cubic meter levels. Both instruments were used to measure and spatially map Hg^0 levels in and around the electrolytic cells as well as upwind and downwind of the cell building.

In addition to point monitoring, profiles of air velocity and Hg^0 concentration were also obtained near the entrance to the roof vent. The measurements were conducted by mounting a sampling line and hot-wire anemometer on a non-conducting mast attached to the upper platform of the movable crane used for cell maintenance. The sampling line was connected to a Jerome 431-X electrical conductivity analyzer with the velocity measurements made at selected intervals along the length of the vent.

Finally, since the determination of air flow is critical to study implementation, special flow visualization equipment was also used as part of the preliminary survey. This equipment included an infrared camcorder to observe and record thermal plumes from the cell building and a commercial smoke generator and associated video camcorder for visualizing the overall flow field within the cell room. Flow

visualization answered several important questions regarding the nature of the air flow pattern inside the building as well as dispersion of the plume after it exits the roof vent.

1.2.2 Winter Sampling Campaign

The overall objective of the winter sampling campaign was to determine the total Hg release from the plant using parallel sampling approaches under typical wintertime meteorological conditions. The activities in the winter campaign included: roof vent monitoring, point source measurements, air flow studies, flux measurements, upwind/downwind monitoring, and waste and product evaluation. The locations of the various activities at the Olin plant site are shown in Figure 1-2.

As stated above, the research described in this report includes only the roof vent monitoring and air flow studies conducted by EPA-APPCCD with contractor support from OPSIS[®], Inc. and ERG. The other related activities performed by study collaborators are briefly summarized below.

Point Source Measurements

The objective of the point measurements was to characterize the distribution of airborne Hg⁰ in the cell room (including the floor below the cells) and around the exterior of the cell building. The primary instrument used for point monitoring was the Tekran Model 2537A automated Hg analyzer. The Model 2537A is a cold-vapor atomic fluorescence (CVAF) spectrometer which is equipped with dual gold traps for preconcentration of the sample prior to analysis. This analyzer was housed in the control room with samples obtained from a high-flow sampling line which extended to a point near the center of the roof vent entrance.

In addition to the Tekran monitoring, walking surveys were also conducted using a Jerome Model 431-X and/or Lumex Model RA-915 instrument. These data were combined with measurements from a hand-held air anemometer to identify potential hot spots and any ancillary emission points found in or around the cell building. Manual “denuders” were also employed to determine the concentration of non-elemental Hg (e.g., divalent Hg compounds) in the cell room. A series of short-duration grab samples was collected from the crane above the south cell line and analyzed on-site using a Tekran Model 2537A.

Preliminary results of these analyses indicate that non-elemental forms of Hg represent $< \sim 5\%$ of the total Hg at the time of sample collection (Landis et al., 2000).

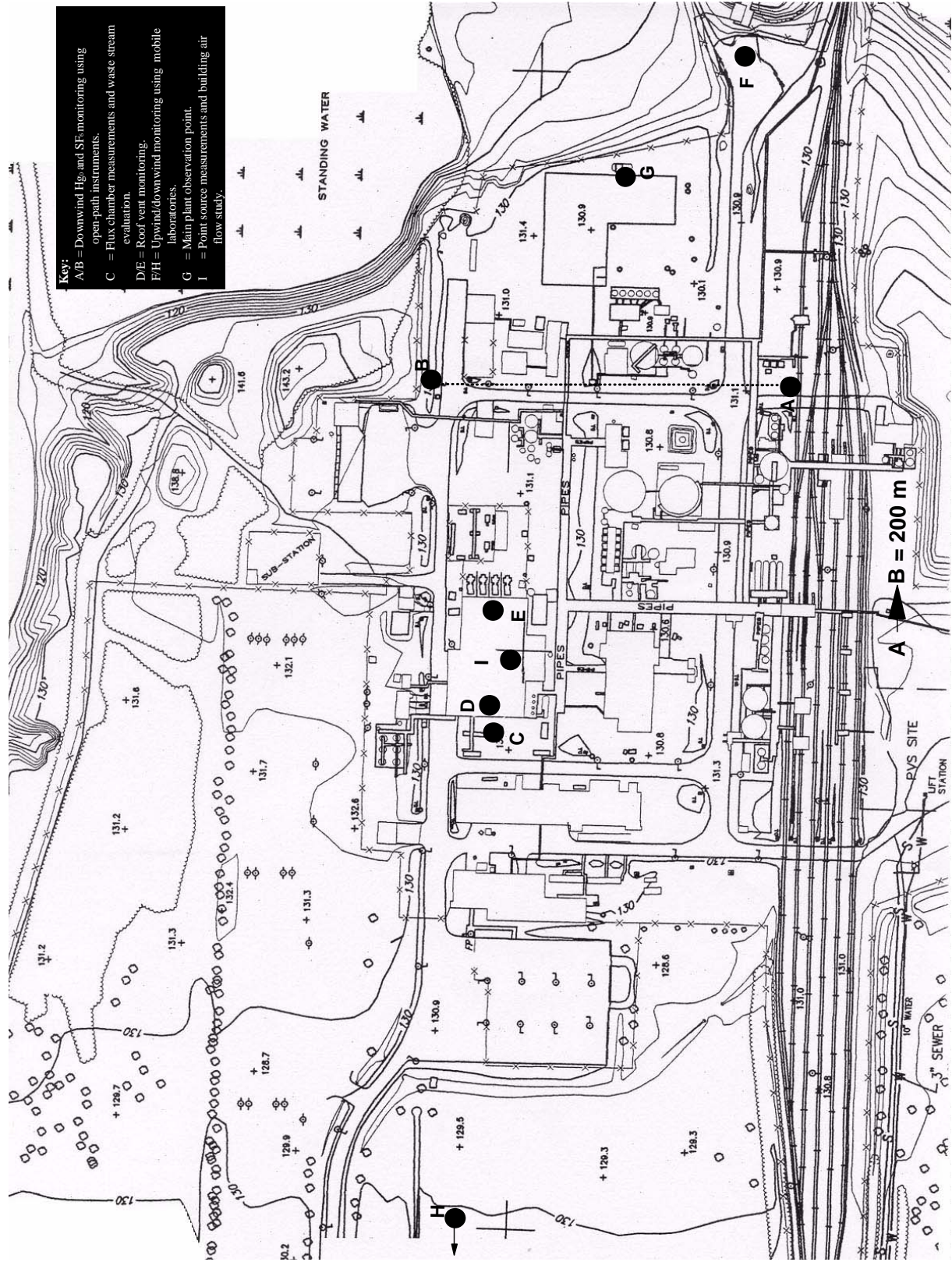

Figure 1-2. Location of measurement activities.

Flux Measurements

Mercury fluxes from surfaces in and around the cell building (especially the basement floor of the building) were also determined to assess the role of these surfaces as sources. Flux chambers of various designs were used over the cell room and ground (basement) floors to determine their source strength and Hg^0 emission characteristics. Chambers were also deployed over old waste deposits within the plant facility and, since solar radiation can strongly influence soil fluxes, operated throughout the diurnal cycle.

Upwind/Downwind Monitoring

Upwind/downwind ambient air monitoring was also conducted as part of the overall program. The purpose of this monitoring was to estimate the total mass flux of Hg compounds from the entire facility as a check on the source estimates obtained within the plant, for model validation purposes, and to collect data which can potentially be compared to similar measurements conducted outside other facilities.

For the upwind/downwind monitoring, instrumentation was deployed at different locations. Tekran analyzers were used in two mobile monitoring laboratories located a significant distance upwind and downwind from the process area (Figure 1-2). (Note that two of the Tekran instruments used in the mobile laboratories were a Model 1130 analyzer and the prototype Model 1135 capable of measuring gas- and particle-phase elemental and non-elemental Hg.) In addition, an open-path Fourier Transform Infrared (FTIR) spectrometer and ultraviolet differential optical absorption spectrometer (UV-DOAS) were also installed near the cell building in the prevailing downwind direction (Figure 1-2). Using the various instruments, the concentration of elemental and non-elemental Hg and SF_6 tracer gas could be determined in near-real-time. (Note that the open-path monitoring was not successful due to atypical wind conditions occurring during the limited 9-day study period.)

Waste and Product Evaluation

Sampling and analysis of liquid and solid wastes and selected liquid product streams were also performed. Wipe samples were also collected from various environmental surfaces including building walls and exterior cell surfaces. These samples were subsequently analyzed for total Hg, Hg^0 , and

dissolved reactive Hg (also referred to as “easily reduced Hg”), as appropriate, using a Tekran analyzer as the primary measurement tool.

1.3 Research Objectives

The overall objective of the roof vent monitoring described in this report was to determine the total Hg⁰ mass flux from the cell building under a range of typical wintertime meteorological conditions. This research was to include both normal operation of the cell building as well as routine maintenance of Hg cells and decomposers. Secondary objectives of the research were to perform an air flow mass balance for the building and to compare various Hg monitoring methods under a variety of sampling conditions. Each of these objectives was met in the study.

1.4 Organization of Report

This report is organized into five additional sections plus references and appendices. Section 2 provides the conclusions and recommendations derived from the study results, and Section 3 describes the mercury cell process and its operation. Section 4 outlines the experimental procedures used in the research, and Section 5 presents and discusses the study results. Finally, Section 6 presents the quality control/quality assurance procedures used in the research to ensure collection of high quality data.

SECTION 2 CONCLUSIONS AND RECOMMENDATIONS

This section provides conclusions drawn from the use of the equipment, methods, and data analysis procedures described in Section 4 to determine the total Hg release and volumetric air flow from the Olin chlor-alkali cell building:

- Elemental mercury concentrations measured by the UV-DOAS varied over an order of magnitude from ~73 to 7.3 $\mu\text{g}/\text{m}^3$. The overall average for the 9-day study period was 24 $\mu\text{g Hg}^0/\text{m}^3$.
- Hg^0 emission rates measured in the roof ventilator varied from 0.08 to 1.2 g/min. An overall average for the monitoring period of 0.36 g/min (472 g/day) was calculated from the data. These values appear to represent only a small percentage of the total potential Hg^0 emissions, however, based on available estimates of the makeup Hg^0 added to the cells on an annual basis.
- A comparison between the concentration of Hg^0 measured by the UV-DOAS and similar measurements conducted using a hand-held instrument across the width of the roof vent showed that the Hg^0 concentrations were relatively consistent across the vent and compare reasonably well to the average concentration obtained with the UV-DOAS.
- Comparison of roof vent monitoring data obtained by the UV-DOAS and point measurements made using a Tekran Model 2537A automated Hg analyzer at the entrance to the vent exhibited a relatively high degree of scatter with only about 63% of the variance explained by linear regression. The data do, however, show comparable trends in Hg^0 concentration with time. Scatter in the data is potentially due to a combination of factors including differences in analysis method, non-representative sampling, and sampling line losses.
- The SF_6 tracer gas results obtained using the long-path FTIR in the roof vent were found to be unusable for the purpose of determining volumetric air flow due to optical saturation of the detector.
- Results of the 24-hour, time-integrated bag sampling showed SF_6 tracer gas concentrations either at or below the instrumental detection limit except for one sampling period on February 20, 2000.

- The average roof vent air velocity measured by a hand-held anemometer as compared to that obtained by the optical anemometer showed that the two methods agreed within $\pm 10\%$.
- Very good closure (79 to 100%) was obtained for each of the three air flow balance calculations performed for the cell building. The three methods also correlate well with each other, and the high degree of closure of these flow balances lends further credibility to the air velocity measurements made by the optical anemometer in the roof ventilator.
- No specific pattern could be discerned from daily plots of Hg^0 emission rates. Various episodic events were observed during the study where the emission rate rose for a period of time, then dropped back to some nominal level which could not be correlated to either process operation or maintenance events using plant records.
- Although the concentration of Hg^0 was found to be relatively homogeneous across the lateral dimension of the roof vent, concentrations of Hg^0 were not consistent along the length of the ventilator.

On the basis of the results obtained for this study, the following recommendations are applicable:

- This study was conducted at one chlor alkali plant, in a time window of approximately 2 weeks. For more thorough characterization of operations in this industry, extended monitoring at a single location and/or monitoring at more plants is recommended to better characterize maintenance events and other operational transients. Better monitoring of these transients is also needed.
- Roof vent instrumentation may be a useful tool for process monitoring in some facilities to identify problems in the operation of the cells that may require corrective action. The long-term suitability of these instruments must be established, however, by additional on-site evaluations.
- The high electromagnetic field at the facility had an adverse effect upon instrument operation. For future studies of this type, optical modems and cables should be used to allow logging of data at a remote location to reduce data loss and make troubleshooting much easier for the operator.
- The variation in Hg^0 concentrations along the length of the ventilator vs. the homogeneous values observed for Hg^0 across the lateral dimension argue strongly for the use of spatially integrated measurements rather than point sampling with a manifold system.
- Roof vent tracer gas data in this study were not usable. Since the use of a tracer is well accepted for determining flow rates, the possibility of tracer gas analyses for future flow measurement studies should not be abandoned. Greater care is needed, however, to verify proper instrument setup and operation.

- The possibility of using different tracer gases has been discussed. Some of these candidate tracer gases (e.g., carbon tetrafluoride) can be determined using UV-DOAS, making concurrent sampling and analysis of mercury and tracer gas highly desirable. Additional research is also recommended to determine the best way to diffuse the tracer gas into the cell room.
- Additional measurements of non-elemental (oxidized) forms of Hg should also be conducted to determine their overall environmental significance.

SECTION 3 PROCESS DESCRIPTION AND OPERATION

3.1 General Process Description

In Hg cell CAPs, Hg⁰ is used as a flowing cathode in electrolytic cells. The Hg electrolytic cell consists of an electrolyzer and a decomposer. In the electrolyzer section, a sodium chloride (NaCl) brine solution flows concurrently with the Hg⁰ cathode. A high current density is applied between the Hg⁰ cathode and metal anodes. Chlorine gas (Cl₂) forms at the anode and a sodium amalgam forms at the Hg⁰ cathode. The amalgam is separated from the brine in a discharge end-box and then enters the decomposer section, where deionized water is added. In the decomposer, the amalgam becomes the anode to a short-circuited graphite cathode resulting in formation of hydrogen (H₂) gas and sodium hydroxide (NaOH), and conversion of the amalgam back to Hg⁰. The Hg⁰ is then recycled to the inlet end-box, where it reenters the electrolyzer. Cell surface temperatures of ~ 66 °C (150 °F) and decomposer surface temperatures of ~ 116 °C (240 °F) are typical at the Olin facility.

The chlor-alkali electrolysis process results in the manufacture of Cl₂, H₂, and NaOH caustic solution. Of these three, the primary product is Cl₂. The overall process reaction is:



Figure 3-1 is a general diagram of the mercury cell process.

3.2 Plant Operation

The basic process flow diagram for the Olin Corporation's Augusta, GA, facility is shown in Figure 3-2. As can be seen, the plant produces NaOH, H₂, and Cl₂ as described above plus HCl and

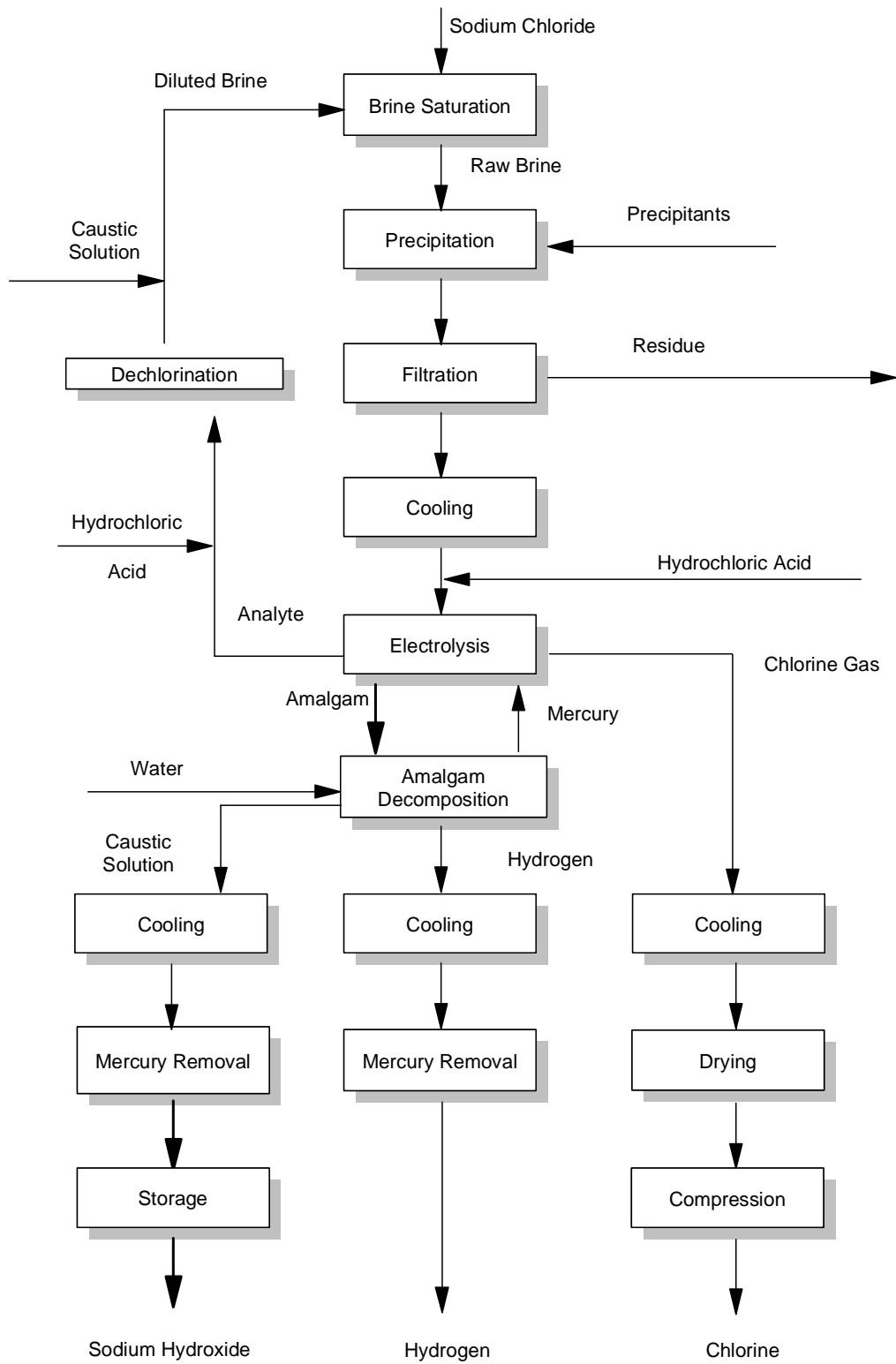

Figure 3-1. Simplified diagram of the mercury cell process.

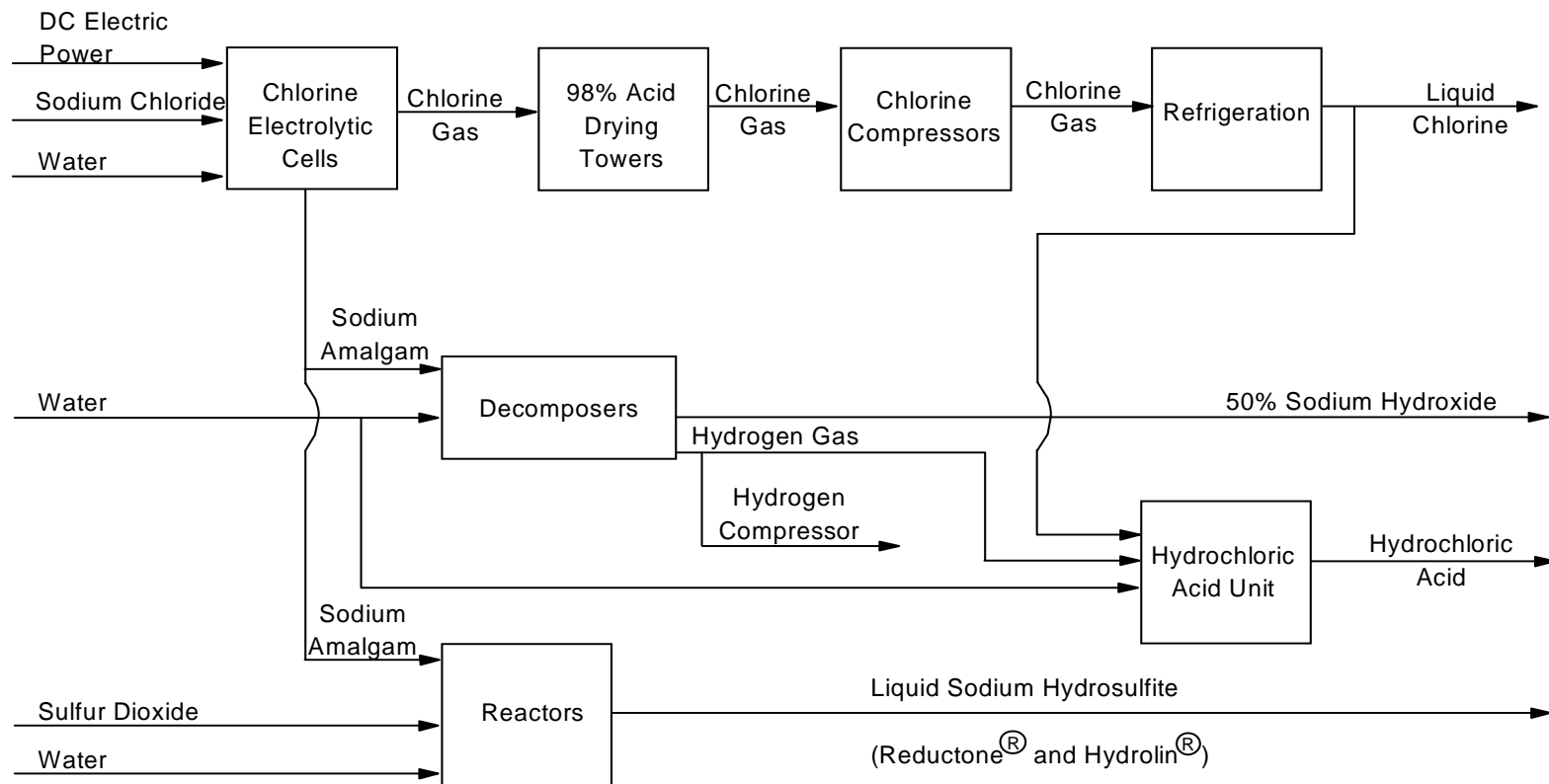

Figure 3-2. Process flow diagram for Olin-Augusta.

liquid sodium hydrosulfite. A description of the various buildings and processes at the facility as provided by Olin can be found in Appendix A.

The Olin facility has a total rated output of 309 Mg/day (340 short tons/day) of Cl_2 , 348 Mg/day (383 short tons/day) of NaOH, and 8.2 Mg/day (9 short tons/day) of H_2 produced by the 60 cells in the building. According to plant records provided to the research team, the process was operated at a relatively constant production rate except for a few brief periods when cells were taken off line for maintenance.

3.3 Cell Building

The cell building at the Olin facility is a single fiberglass and steel structure approximately 62 m (204 ft) long by 34 m (112 ft) wide which is generally oriented in a east/west direction. The peak of the building is located approximately 16 m (51 ft) above grade with a single monovent (Figures 3-3a and 3-3b) running its entire length.

The Hg cell building consists of two floors. The ground floor (basement) is used for storage tanks and various other process equipment and, except for the Reductone[®] area, is open to the atmosphere on three sides. The Hg cells and associated decomposers are mounted on a support structure on the cell room floor which is open to the basement below except for concrete aisles along the edges and through the center of the cell array. In this configuration, each cell is exposed to ventilation air used for cooling or worker protection.

The cell building houses the 60 electrolysis cells (Figures 3-4 and 3-5) containing a total estimated Hg inventory of ~ 169,000 kg (372,000 lb). In 1997, 7,444 kg (16,411 lb) of “virgin” makeup Hg was supplied to the cells (Rosario, 2001). This amount of makeup Hg represents ~5% of the total quantity used by all plants in the chlor-alkali industry during that year (Rosario, 2001).

The electrolytic cells in the Olin cell building are mounted in two rows of 30 units each which run east to west (Figure 3-6). The cell rows are separated by a ~ 2.4 m (8 ft) wide aisle running along the centerline of the building with other, ~ 3.4 m (11 ft) wide aisles located along the perimeter of the cell rows to allow access for equipment maintenance. The decomposers used for Hg recovery (Figure 3-7) are located on the end of each cell near either the north or south wall.



Figure 3-3a. Cell building showing interior of roof ventilator.



Figure 3-3b. Cell building showing exterior of roof ventilator (from north).

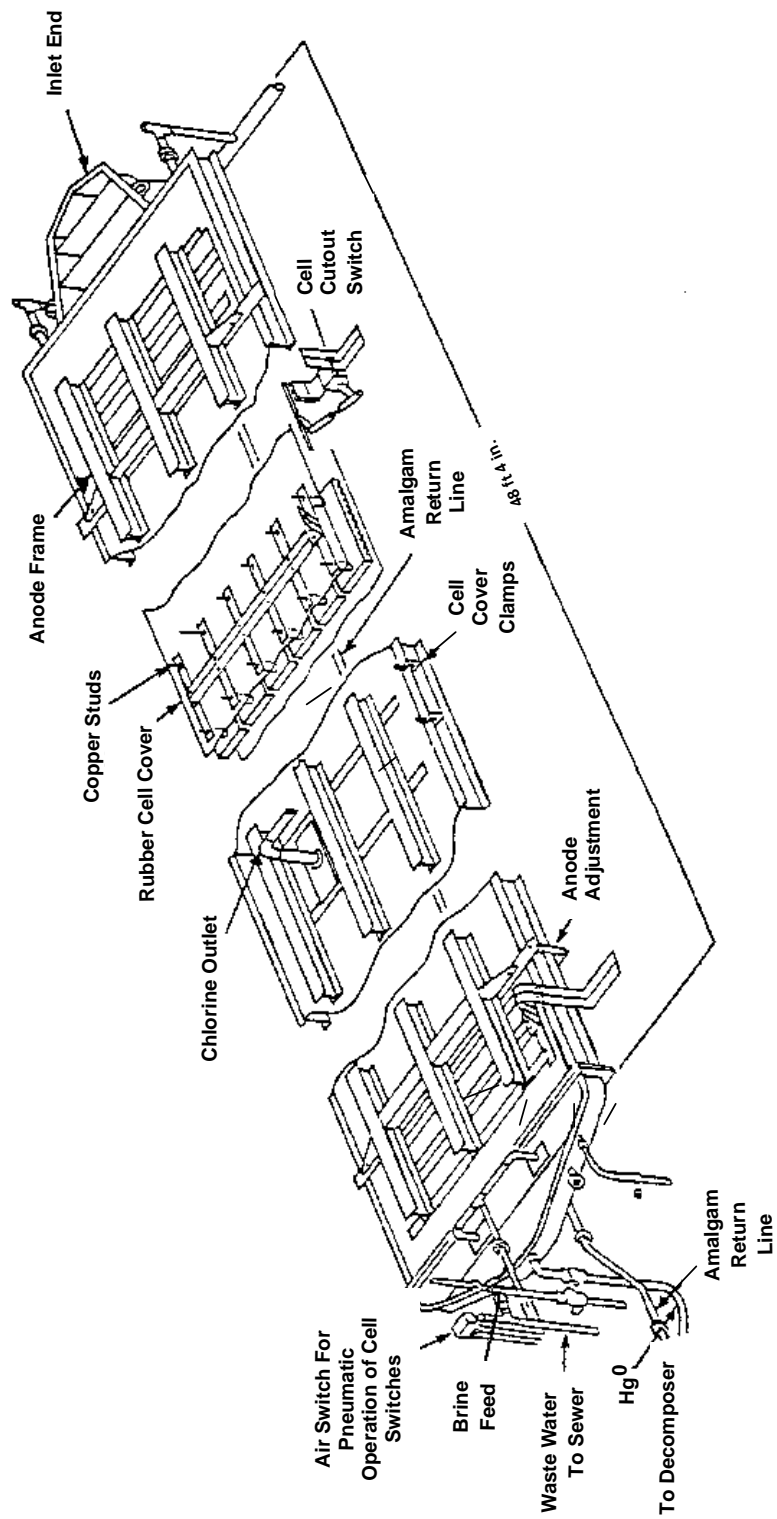

Figure 3-4. Electrolyzer used at the Olin-Augusta plant.

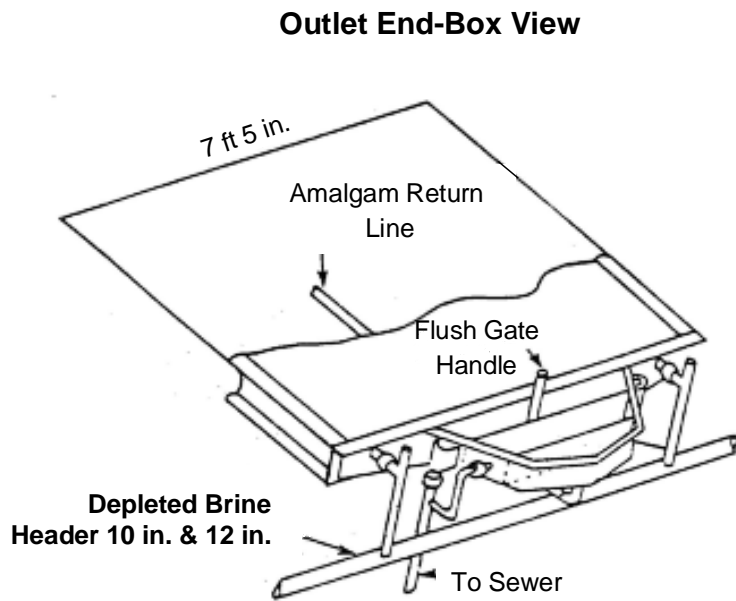
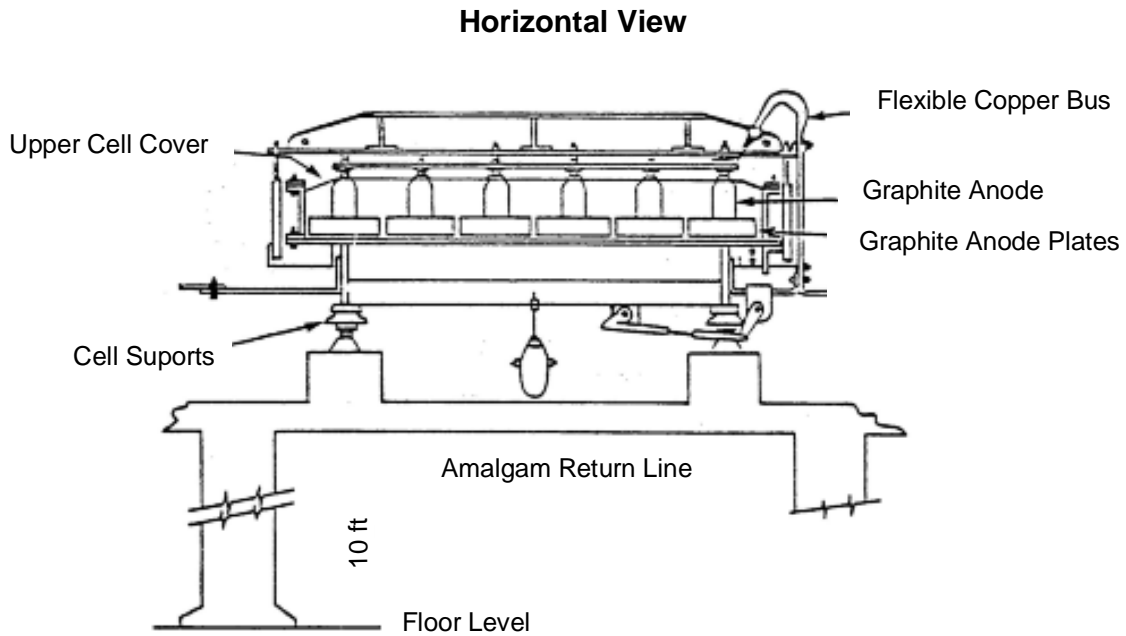

Figure 3-5. Mercury cell: horizontal view and outlet end-box view.



Figure 3-6. North line of electrolytic cells in Olin cell building.

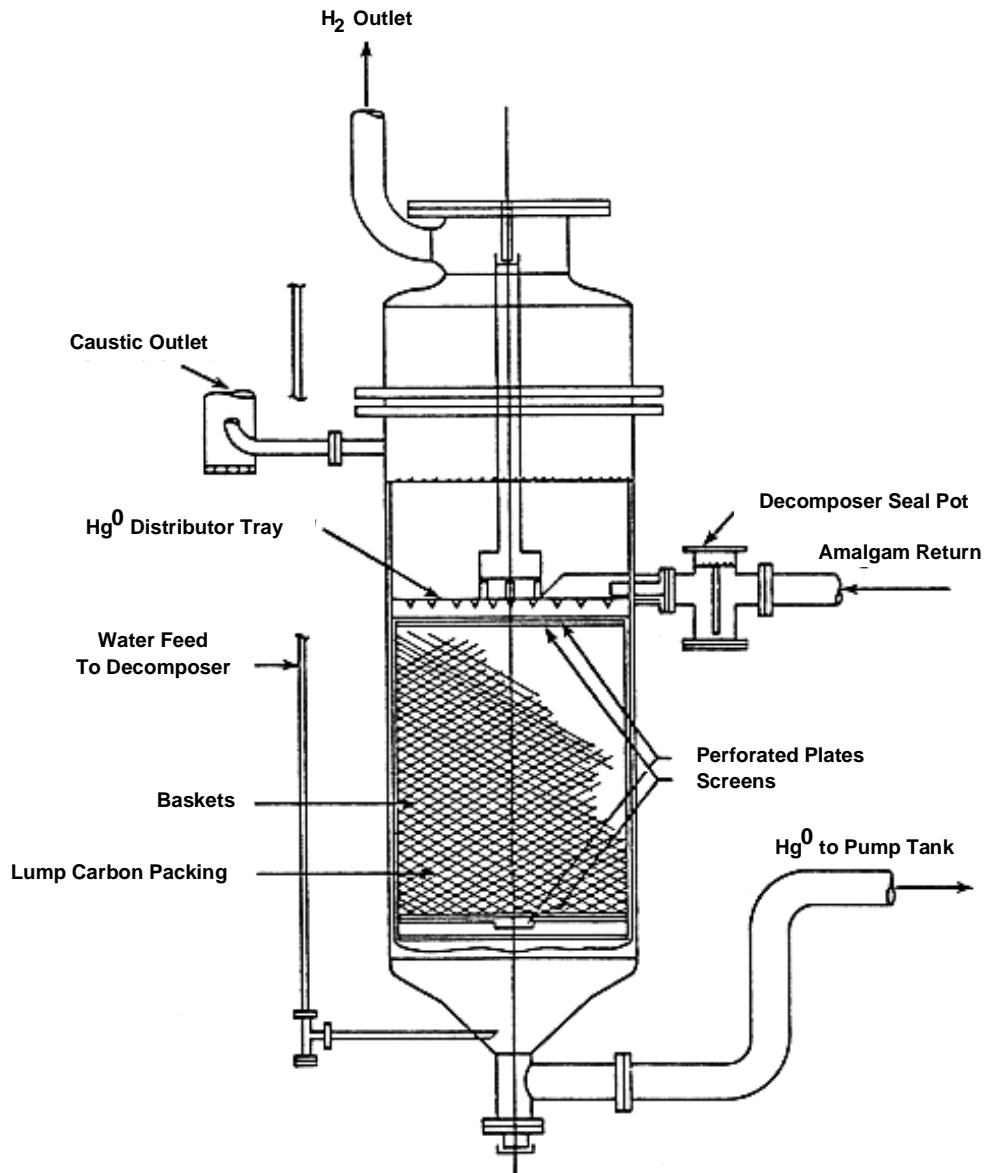

Figure 3-7. Decomposer used at the Olin-Augusta plant.

The building is ventilated by natural convection with three sides of the basement and cell room floor (except for the Reductone[®] area) open to the atmosphere. During colder weather, two large sliding doors on the west end of the cell room floor can be closed to reduce ventilation. Also, various 1.1 m (3.7 ft) high panels located on the north and south sides of the building can be either removed or replaced as ambient conditions dictate.

To further assist with ventilation of the cell room, 13 large axial-blade fans located in and along the walls can also be operated, as needed, depending on ambient temperature. Each of these fans is rated at 626 actual m³/min (22,100 actual ft³/min) and is manually activated/deactivated by operating personnel. A general diagram of the cell building, showing the cell rows and general fan locations, is shown in Figure 3-8.

In general, the internal temperature of the cell room varies with the ambient outdoor temperature. The impact of this variation on ventilation rate is discussed in further detail in Section 4.2.3 below.

In the northwest corner of the cell building is the Reductone[®] process area. This area contains reactors used for the production of 303,000 L/day (80,000 gal./day) of liquid sodium hydrosulfite which is operated from a separate control room in that part of the building. Since sodium amalgam from the electrolytic cells is used in this process, the Reductone[®] area is also a source of fugitive Hg emissions.

Finally, based on observations made during the study, the Olin chlor-alkali plant appeared to be a very well operated and maintained facility. General housekeeping of the cell building and adjacent areas was excellent and the Olin staff were found to be highly motivated to reduce Hg emissions from the process. Periodic maintenance was also performed throughout the study period as part of the normal operation of the cell building. In addition, two specific maintenance events expected to generate elevated Hg levels were monitored: a cell opening and a decomposer “basket” changeout. To facilitate maintenance, both operations were conducted after the equipment had been taken off-line and allowed to cool. (Note that cooling of hot process equipment before opening is not only a good maintenance practice, but also a good engineering practice to minimize release of Hg emissions.) Neither of these events resulted in abnormally high Hg⁰ concentrations either in the area adjacent to the maintenance activity or in the roof vent.

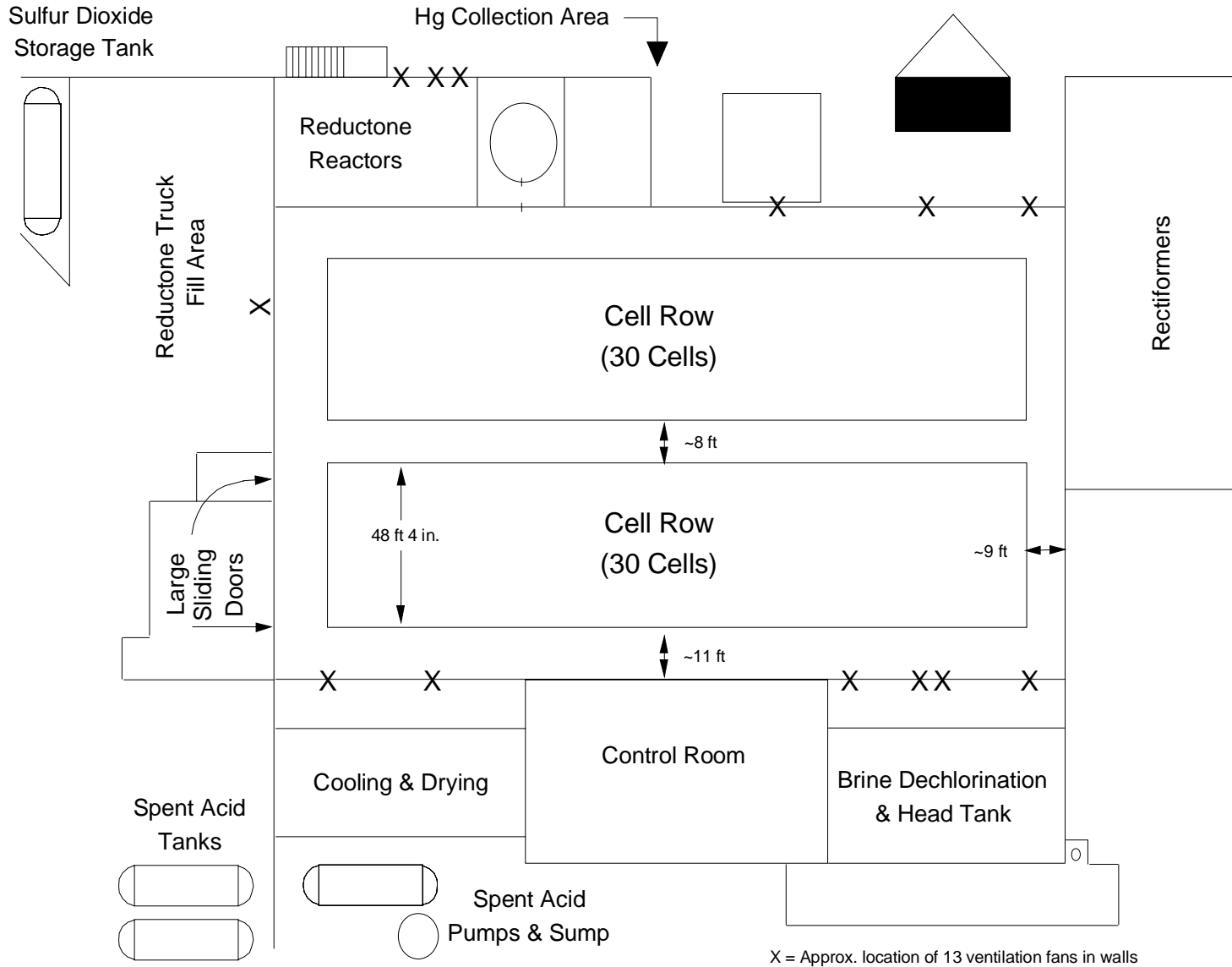

Figure 3-8. General diagram of the cell building showing cell rows, general fan locations, etc.

SECTION 4 EXPERIMENTAL PROCEDURES

This section provides detailed information on the field measurements conducted during the period February 17 to 25, 2000. Both the manual and automated techniques are described along with the procedures used to reduce and analyze the experimental data.

4.1 Measurement Methods, Setup, and Calibration

A combination of measurement methods was used for data collection at the Olin chlor-alkali facility. Past studies of this type show that parallel approaches reduce the overall uncertainty of the estimates and provide useful constraints on measurement accuracy. The methods used were: roof vent monitoring, tracer gas analyses, and manual velocity measurements. Each is described in detail below.

4.1.1 Roof Vent Monitoring

The basic measurement approach used in this portion of the research was the “roof monitor method” developed in the late 1970s for fugitive emissions (Cowherd and Kinsey, 1986). In this particular study, however, long-path instruments were used in lieu of extractive sampling using a manifold system (EPA, 1984). The use of long-path instruments allows measurements to be made on a spatially integrated basis, thus eliminating problems with representative sampling typical of point measurements.

The primary instrumentation used in the roof vent consisted of:

- UV-DOAS for the measurement of Hg⁰ concentration;
- Optical scintillometer (anemometer) for the determination of air velocity; and
- FTIR spectrometer for the measurement of SF₆ tracer gas concentration.

This equipment was selected because it has been used successfully for testing of similar emissions in other industries monitoring roof vents. In fact, the Model LOA-104 optical anemometer has recently received an EPA Reference Method 14 equivalency designation for the determination of air velocity in aluminum pot room roof vents (EPA, 1984; Hunt, 1998). The long-path instruments used for roof vent monitoring are described in Table 4-1.

Table 4-1. Roof Vent Instrumentation

Parameter Monitored	Type of Instrument	Manufacturer	Model No.	Optical Configuration^a
Gas-phase Hg ⁰	UV-DOAS	OPSIS™, Inc.	Model AR 500	Bi-static
Air velocity	Optical scintillometer (anemometer)	Scientific Technology	Model LOA-104 ^b	Bi-static
SF ₆ tracer gas concentration	FTIR	Environmental Technologies Group	Air Sentry	Mono-static

^a Bi-static = separate light source and receiver; mono-static = combination light source and receiver in one unit.

^b Modified with a 2-in. aperture in place of the standard 6-in. aperture for path lengths <100 m.

The long-path instruments were mounted on wooden sampling platforms erected at the east and west ends of the cell building roof vent (Figure 4-1). The UV-DOAS receiver, FTIR, and optical anemometer transmitter were located on the west platform with the UV-DOAS transmitter (light source), a retroreflector, and the optical anemometer receiver mounted on the east platform. Except for the optical anemometer, the signals from all instruments were directed by optical fiber to computerized data acquisition systems (DASs) located in a trailer parked directly beneath the roof ventilator at the west end of the cell building. For the optical anemometer, the microprocessor and associated laptop computer used for data acquisition were located on the sampling platform itself. This arrangement was necessary due to the high electromagnetic field which precluded the use of the low-voltage modems supplied with the instrument. Due to practical considerations, the optical measurement path of all the instruments was positioned slightly above the exit plane of the ventilator “throat” as shown in Figure 4-2.

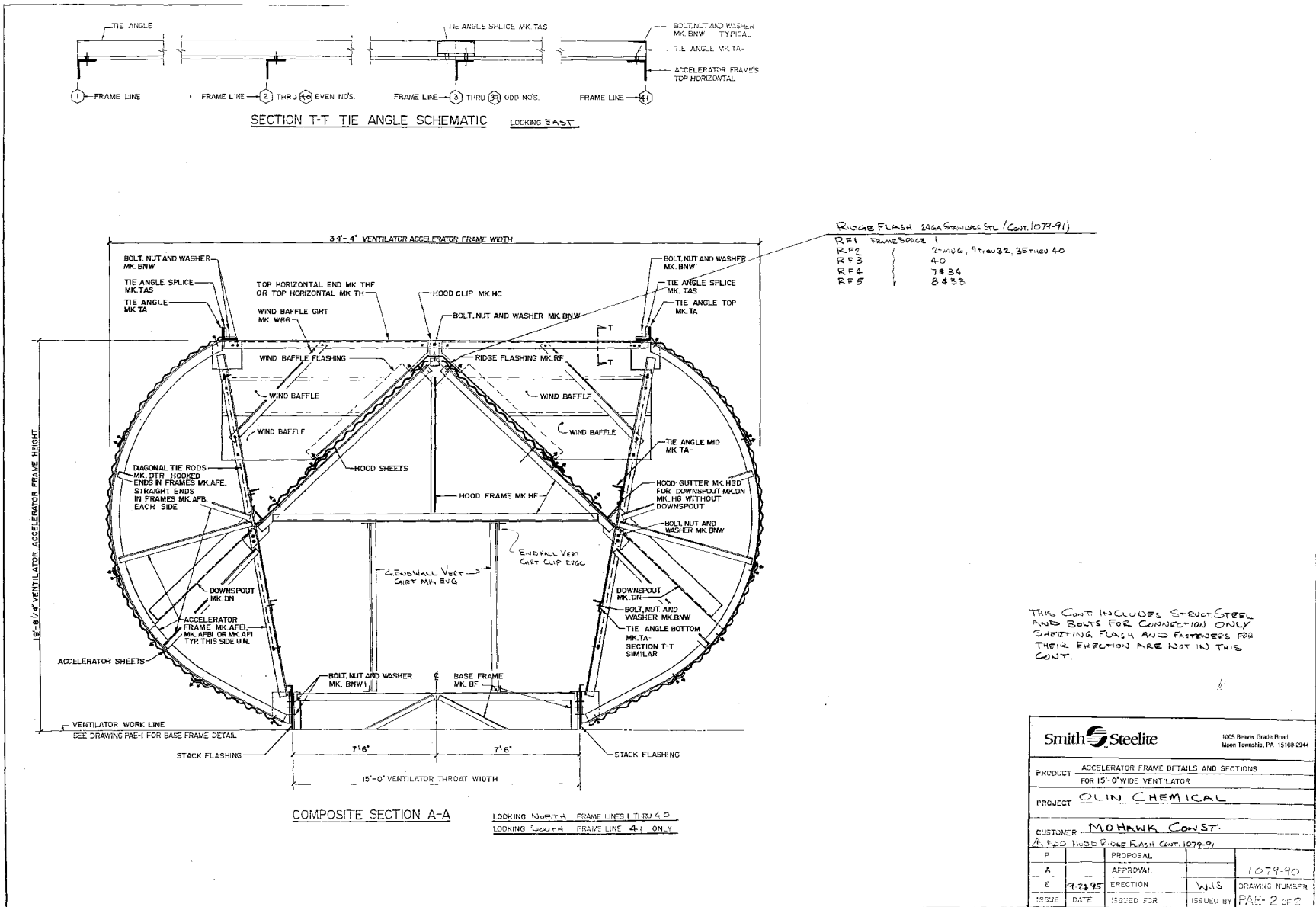

Figure 4-1. Cross-section of roof ventilator showing internal structure.



Figure 4-2. From left to right, the FTIR retroreflector, UV-DOAS light source, and optical anemometer receiver unit installed on the east sampling platform.

Each instrument was set up and calibrated according to the operating manual and/or approved Quality Assurance Project Plan (QAPjP) for the study (Kinsey et al., 2000). For the UV-DOAS, both the transmitter and receiver units were bolted to steel plates attached to the internal building structure at the approximate centerline of the vent cross section. Instrument calibration was performed at the beginning and end of the study using a sealed Hg gas cell placed in the measurement path. Daily checks of instrument performance were made by OPSIS[®] personnel who operated and maintained the UV-DOAS during the course of the study.

For operation of the optical anemometer, the transmitter and receiver were bolted directly to the wooden platform on the south side of the roof vent centerline. The instrument was initially compared against a standard unit evaluated in the National Institute for Standards and Technology (NIST) low-speed wind tunnel and thus is considered to be NIST-traceable. Since a dynamic calibration could not be performed on site, daily quality control (QC) checks were made each morning using the electronic calibrator supplied with the instrument. In addition, two sets of manual velocity measurements were also made as a comparison with the readings made by the optical anemometer as described below.

The open-path FTIR and associated retroreflector were also bolted to the wooden platforms on the north side of the roof ventilator centerline. The instrument was calibrated both before and after the main data collection period using a nitrogen purge followed by 500 ppmv *n*-butane and 25 ppmv SF₆ according to EPA Method TO-16 (EPA, 1999). Daily QC checks were also made by the instrument operator. A diagram showing the location and beam path of each long-path instrument relative to the roof vent cross section is shown in Figure 4-3.

Finally, a Met One Model 062 temperature controller and meteorological station and associated laptop computer were also installed on the west sampling platform to monitor air temperature and relative humidity. This system provided 15-min average data for these two parameters as logged by the computer. (Note that the high electromagnetic field precluded the transfer of electronic files from the meteorological station computer *in-situ* and thus the data were provided as hard copy output directly from the computer.) Note, however, that the meteorological station was not available until about midday on February 21, and thus temperature and humidity data are not available for the entire study. The available data were analyzed, however, to estimate the air temperature for periods where actual monitoring was not conducted. Ambient data for the study period were also obtained either from

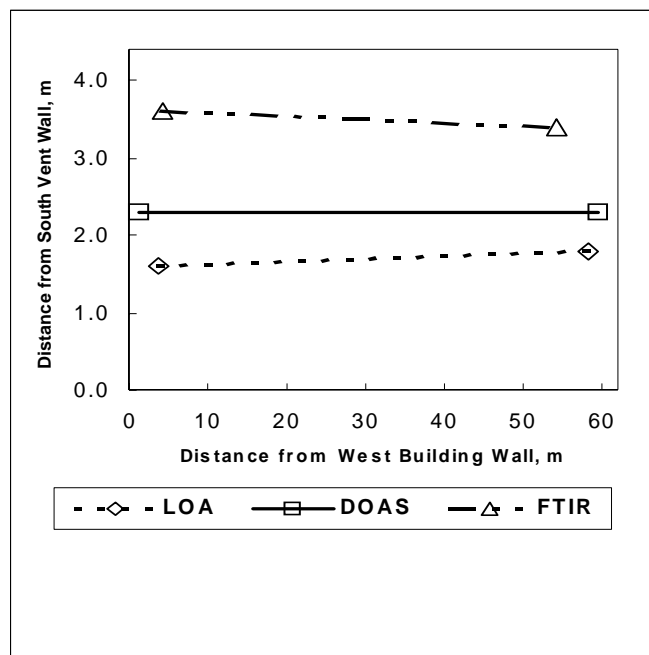

Figure 4-3. Relative locations of instrument beam path in roof vent cross section.

on-site meteorological monitoring conducted by study collaborators or from National Weather Service (NWS) archives for Bush Airport located ~ 2.4 km (1.5 mi) north of the facility.

With regard to on-site data processing and storage, the raw data stream from each instrument was continuously logged and accumulated by the associated DAS. For QC purposes, a copy of each instrument data file was made by the EPA Work Assignment Manager on a daily basis and stored separately both in electronic format and as hard copy. The hard copy data were stored in ring binders to provide a permanent record for the study.

4.1.2 Manual Tracer Gas Analyses

The SF₆ tracer gas concentration was measured inside the Hg cell building by ERG’s Optical Measurements Group using manually operated bag samplers and a closed-cell Nicolet Magna 760 FTIR to analyze the gas samples. The roof vent and upwind/downwind monitoring was conducted using EPA-operated FTIRs to determine tracer gas concentrations. All analyses and measurements for the tracer gas were completed following EPA Method TO-16 (EPA, 1999).

Manual sampling was accomplished by drawing sample air into a Tedlar® bag over a nominal 24-hour period. Tedlar® bags were used for air sampling, and were constructed of a material that minimizes adsorption of many ambient air chemical species. Tedlar® bags will be referred to as “bags” for the remainder of this section. A bag sampling location consisted of a rigid container with an enclosed bag, a sample pump to pull a vacuum on the container, and associated flow measurement and control devices (rotameters).

Sampling was achieved by placing an evacuated bag inside the container, sealing the container, and attaching a pump and sampling lines to the container. The sample pump was started and withdrew air from the container, creating a vacuum within the container which then inflated the bag by drawing in sample air. Sampling rate was controlled by adjustment of the pump flow rate.

Multiple sampling locations were used to obtain a distribution of tracer concentration at key locations in and around the cell building. The locations were sampled nearly simultaneously for approximately 24 hours. Sampling locations were determined based on estimated air flow patterns and/or wind conditions prior to sampling.

Prior to sampling, all equipment was inspected for proper operation. Bags were inspected for integrity, and the sampling containers were inspected and tested for leaks. When all equipment passed inspection, the equipment was placed in its designated sampling location and assembled. All clocks used during sampling were synchronized with a master clock set to the atomic clock in Boulder, CO.

Due to the density difference between air and SF₆, all flowmeters were calibrated with tracer gas before sampling using a manual Buck calibrator. After the bag samples were obtained, they were removed from the rigid container (10-gal. drum), labeled, and transported to the trailer for analysis. All samples were analyzed at Olin using the ERG Nicolet FTIR.

The bag samples were analyzed by FTIR spectroscopy because of the high sensitivity of FTIR to SF₆ and the ability of FTIR to simultaneously detect many other analytes of interest. The FTIR operating parameters are given in Table 4-2. These parameters provide acceptable detection limits for the target analytes anticipated in this study.

Table 4-2. Typical FTIR Operating Parameters

Parameter	Value
Spectral Range (cm ⁻¹)	400 - 4000
Spectral Resolution (cm ⁻¹)	≤0.5
Optical Cell Pathlength (m)	10 (approximate)
Optical Cell Temperature (°C)	Ambient (nominally 25°C)
Sample Volume (L)	3
Integration Time (min)	6 (Average of 256 interferograms)

Prior to each day's analysis, the FTIR instrument was checked for proper operation, and a background spectrum was collected using ultra-high purity nitrogen. A background spectrum was considered a zero-response measurement. After the background spectrum was collected, QC measurements were performed at nominal SF₆ concentrations of 0.1 and 0.5 ppm (volume). QC results are described in detail in Section 6.

4.1.3 Manual Velocity Measurements

Manual anemometer measurements were also performed as part of the study. The objective of these measurements was to evaluate air velocity in the roof vent as an independent check on the optical anemometer as well as to determine the air velocity in various building openings for the purpose of performing an overall flow balance for the cell building.

The original study design proposed the use of three specially designed "anemometer trees" (ATREEs) for the determination of air velocity and air flow. The ATREEs consisted of multiple thermal anemometer probes which were mounted on a movable metal mast and connected to a central data logger. Upon initial deployment, however, it was determined that the thermal anemometers used in the ATREEs were far too sensitive for these measurements and immediately went off-scale. Therefore, a hand-held, Davis Instruments TurboMeter[®] propeller anemometer was used for the manual velocity measurements. This instrument is capable of integrated air velocity measurements down to 0.1 m/s and thus was well suited to this particular application. The propeller anemometer was also compared with a hand-held

hot-wire instrument during selected measurement periods. Since propeller data were available for all of the manual measurements, only this information was used in the analyses described below.

Propeller anemometer readings were obtained both in the roof ventilator and in cell building openings. For the vent measurements, readings were made at selected locations across the width of the ventilator throat both at the same height as the optical anemometer measurement path and also ~ 20 cm (8 in.) below the throat exit. For the various building openings, anemometer readings were obtained at the approximate geometric center of each opening. All data collected during the manual velocity measurements were recorded by hand in a bound field notebook.

4.2 Data Reduction and Analysis

The data reduction and analyses conducted in the study are described below. Copies of the Excel[®] spreadsheets containing the reduced data are appended, as appropriate.

4.2.1 Roof Vent Monitoring

For the Hg⁰ concentration measurements made by the UV-DOAS, the raw 30-sec average values generated by the spectrometer were downloaded directly from the instrument in the form of an ASCII text file for each day of the study. The individual text files were then imported into separate pages of an Excel[®] spreadsheet where the data were checked for any obvious errors or anomalies. Any entries in the spreadsheet which appeared corrupted or questionable were deleted, the remaining information plotted as a chronology, and summary statistics calculated for each 24-hr period. In addition, a second data set consisting of 1-min averages was downloaded from the DAS for the purpose of the emission rate calculations. These data were analyzed in a similar fashion except that graphs and summary statistics were not generated.

A similar procedure was also used for analysis of the optical anemometer results. In this case, however, raw 1-min averages were generated by the instrument and were imported as ASCII text files into the spreadsheet pages. Due to the high electromagnetic field and subsequent frequency of corrupted data, special care was taken to check each data line prior to further reduction and analysis. Note, however, that the data generated by the optical anemometer were provided at actual roof vent temperature and pressure,

whereas the DOAS results were reported at a constant temperature of 30 °C (86 °F) and pressure of 760.7 mm Hg (29.95 in. Hg). Therefore, an appropriate temperature and pressure correction was applied to the optical anemometer results prior to the two data sets being used to calculate Hg⁰ emission rates.

For the roof vent meteorological station, the temperature and humidity data were entered by hand into a spreadsheet from the hard copy records. The data entries were then checked by the analyst for accuracy. These data were later combined with applicable ambient temperature information to make the necessary corrections for the emission rate calculations described below.

Finally, probably the most complex data set to be analyzed was that obtained from the roof vent FTIR. This data set consisted of individual infrared (IR) spectra generated by the instrument from 64 separate scans conducted over a time period of approximately 5 min. The individual spectra were analyzed by post-processing to determine the concentration of SF₆ and other gases of interest.

Data files containing the FTIR spectra were provided to two separate EPA contractors for post-test data reduction and analysis. An initial set of ~ 300 spectra collected late in the study was first provided to Jeff Childers of ManTech, Inc., who developed the basic spectral analysis scheme and provided a quality control check of the data (Appendix B). A complete set of spectra (including those provided previously to ManTech) was also furnished to EPA's in-house contractor (ARCADIS Geraghty & Miller) who conducted a separate analysis (Appendix C) of the information generated in the field using the methodology developed by Childers.

As stated in Childers' report (Appendix B), the FTIR detector was found to be optically saturated due to poor instrument setup in the field. Because of detector saturation, the response of the instrument is highly non-linear, making quantitative interpretation of the spectra impossible. Therefore, the entire data set was considered to be unuseable for the quantitative determination of air flow rate from the cell building. The data are of some qualitative interest, however, as discussed in Section 5.

4.2.2 Tracer Gas Analyses

The SF₆ tracer gas was released as a diffuse line source along the centerline of the cell room. The tracer was provided from two separate compressed gas cylinders through a 'soaker hose' running the length

of the building. Figure 4-4 shows the cylinder layout along the cell building basement. Figure 4-5 shows the soaker tubing layout inside the cell room.

Gas was metered from the cylinder using a pressure regulator and precision rotameter which was calibrated in the field with SF₆ using a bubble test meter prior to use. Single-point calibration checks

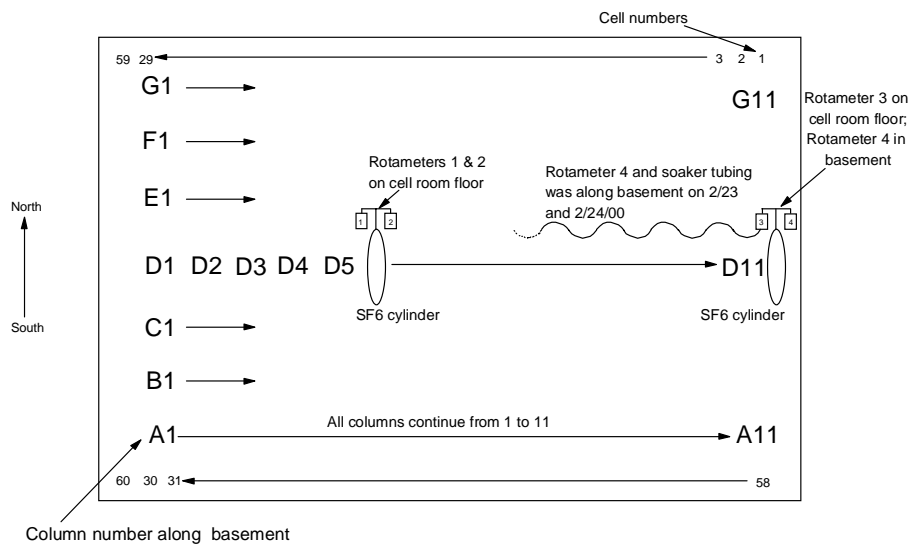

Figure 4-4. Cylinder layout along the cell building basement.

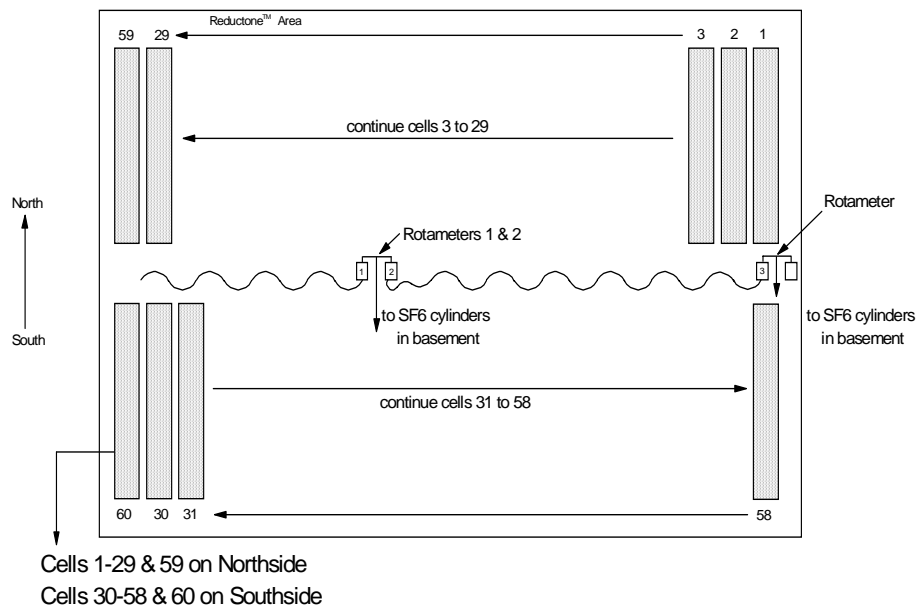

Figure 4-5. Soaker tubing layout inside the cell room.

were made at the beginning, middle, and end of the tests. Calibration checks are presented in Section 6 (Quality Assurance/Quality Control).

The total average gas release for the first 3 days of sampling, February 17 through February 20, 2000, was 137.4 g/min. Gas concentration was increased on February 21, 2000, because the FTIR instrument was detecting baseline amounts of SF₆. The average release from February 21 to 23, 2000, was 248.1 g/min. Because there was still a problem with the detection of SF₆ from the long-path roof vent FTIR, the rotameters were exchanged and calibrated, and a higher flow was set to run the last 2 days of sampling, February 23 and 24, 2000. The average release was 3356.0 g/min. Gas release concentrations are listed in Table 4-3.

4.2.3 Emission Rate Calculations

Using the data sets described in Section 4.2.1 above, the emission rate for each 1-min averaging period was calculated according to:

$$E = 60V_c A_e C (10)^{-6} \quad (4-1)$$

Where:

- E = Hg⁰ emission rate (g/min);
- V_c = air velocity obtained from optical anemometer corrected for temperature and pressure (m/s);
- A_e = effective flow area of vent (m²); and
- C = Hg⁰ concentration as measured by the UV-DOAS (μg/m³).

The corrected air velocity was calculated by Equation 4-2 as:

$$V_c = V_a \frac{T_r P_a}{T_a P_r} \quad (4-2)$$

Where:

- V_a = air velocity obtained from optical anemometer at actual conditions (m/s);
- T_r = reference absolute temperature (303 K);

Table 4-3. Gas Release Concentrations

Date	Time	Rotameter Concentration mL/min ^a				SF ₆ Concentration (g/min) ^b				Comments		
		Rotameter Site Location ^c				Rotameter Site Location ^c						
		1	2	3	4	Total Flow	1	2	3	4	Total Flow	
2/17	18:30	8.8	7.4	9.4		25.6	45.0	38.2	48.1		131.2	Density of SF ₆ = 5.13 g/mL
	19:00	8.8	7.4	9.4		25.6	45.0	38.2	48.1		131.2	
2/18	9:00	20.9	3.5	21.1		45.5	107.2	17.7	108.3		233.2	
	9:01	8.8	7.4	9.4		25.6	45.0	38.2	48.1		131.2	
	10:00	8.8	6.6	9.4		24.8	45.0	34.1	48.1		127.1	
	11:30	8.8	7.4	9.4		25.6	45.0	38.2	48.1		131.2	
	12:10	8.8	7.4	9.4		25.6	45.0	38.2	48.1		131.2	
	16:00	8.8	7.4	9.4		25.6	45.0	38.2	48.1		131.2	
	17:10	8.8	6.1	9.4		24.3	45.0	31.4	48.1		124.4	
	17:11	8.8	7.4	9.4		25.6	45.0	38.2	48.1		131.2	
	17:30	8.8	6.1	8.4		23.2	45.0	31.4	42.9		119.2	
	17:31	8.8	7.4	9.4		25.6	45.0	38.2	48.1		131.2	
	17:45	8.8	7.4	9.4		25.6	45.0	38.2	48.1		131.2	
	18:00	8.8	7.4	9.4		25.6	45.0	38.2	48.1		131.2	
2/19	7:40	7.8	16.8	17.8		42.3	39.9	86.0	91.1		217.0	
	7:41	8.8	7.4	9.4		25.6	45.0	38.2	48.1		131.2	
	9:00	8.8	7.4	9.4		25.6	45.0	38.2	48.1		131.2	
	10:15	8.8	5.6	6.0		20.4	45.0	28.6	30.9		104.5	
	10:16	8.8	7.4	9.4		25.6	45.0	38.2	48.1		131.2	
	10:50	8.8	7.4	9.4		25.6	45.0	38.2	48.1		131.2	
	11:45	8.8	7.4	9.4		25.6	45.0	38.2	48.1		131.2	
	12:45	7.8	6.9	9.4		24.1	39.9	35.5	48.1		123.5	
	12:46	8.8	7.4	9.4		25.6	45.0	38.2	48.1		131.2	
	13:39	8.8	7.4	9.4		25.6	45.0	38.2	48.1		131.2	
	14:30	8.8	7.4	9.4		25.6	45.0	38.2	48.1		131.2	
	14:57	8.8	6.6	9.4		24.8	45.0	34.1	48.1		127.1	
	14:58	8.8	7.4	9.4		25.6	45.0	38.2	48.1		131.2	
	16:40	8.8	7.4	9.4		25.6	45.0	38.2	48.1		131.2	
	17:00	7.1	6.1	9.4		22.6	36.6	31.4	48.1		116.0	
	17:01	8.76	7.44	9.37		25.6	45.0	38.2	48.1		131.2	
	2/20	8:30	8.76	19.4	24.5		52.7	45.0	99.7	125.5		270.1
8:31		8.76	7.44	9.37		25.6	45.0	38.2	48.1		131.2	
9:30		8.76	7.44	9.37		25.6	45.0	38.2	48.1		131.2	
10:30		7.78	7.44	9.37		24.6	39.9	38.2	48.1		126.2	
10:31		8.76	7.44	9.37		25.6	45.0	38.2	48.1		131.2	
11:00		5.49	6.11	11.0		22.6	28.1	31.4	56.7		116.2	Average in g/min 137.4
11:01		8.76	7.44	9.37		25.6	45.0	38.2	48.1		131.2	
2/20	15:00	13.7	11.4	14.4		39.5	70.2	58.7	73.9		202.8	
	16:00	13.7	11.4	14.4		39.5	70.2	58.7	73.9		202.8	

(Continued)

Table 4-3. (Continued)

Date	Time	Rotameter Concentration mL/min ^a					SF ₆ Concentration (g/min) ^b					Comments
		Rotameter Site Location ^c					Rotameter Site Location ^c					
		1	2	3	4	Total Flow	1	2	3	4	Total Flow	
2/21	8:30	13.7	16.8	21.1		51.6	70.2	86.0	108.3		264.5	
	8:31	13.7	11.4	14.4		39.5	70.2	58.7	73.9		202.8	
	9:30	13.7	10.1	12.7		36.5	70.2	51.9	65.3		187.3	
	9:31	13.7	11.4	14.4		39.5	70.2	58.7	73.9		202.8	
	10:35	13.7	8.78	11.0		33.5	70.2	45.0	56.7		171.9	
	10:36	13.7	11.4	14.4		39.5	70.2	58.7	73.9		202.8	
	11:40	13.7	11.4	14.4		39.5	70.2	58.7	73.9		202.8	
2/22	10:15	13.7	11.4	14.4		39.5	70.2	58.7	73.9		202.8	
	11:00	13.7	8.78	11.0		33.5	70.2	45.0	56.7		171.9	
	11:01	13.7	11.4	14.4		39.5	70.2	58.7	73.9		202.8	
	11:20	13.7	8.78	11.0		33.5	70.2	45.0	56.7		171.9	
	11:21	13.7	11.4	14.4		39.5	70.2	58.7	73.9		202.8	
	12:00	15.0	8.78	11.0		34.8	76.9	45.0	56.7		178.6	
	12:01	13.7	11.4	14.4		39.5	70.2	58.7	73.9		202.8	
	14:00	13.7	11.4	14.4		39.5	70.2	58.7	73.9		202.8	
	15:00	13.7	11.4	14.4		39.5	70.2	58.7	73.9		202.8	
	19:40	13.7	11.2	14.1		38.9	70.2	57.3	72.2		199.7	
2/23	19:41	13.7	11.4	14.4		39.5	70.2	58.7	73.9		202.8	Average in g/min 248.1
	10:00	47.7	66.9	35.0		149.7	244.9	343.4	179.7		768.0	
	10:01	47.7	43.1	47.2		138.0	244.9	221.3	242.0		708.2	
												New rotameters
2/23	11:30	59.4	43.1	47.2	51.2	200.9	304.7	221.3	242.0	262.8	1030.8	
	14:00	59.4	43.1	47.2	51.2	200.9	304.7	221.3	242.0	262.8	1030.8	Average in g/min 1606.3
	16:15	59.4	209.7	217.1	51.2	537.5	304.7	1076.0	1113.9	262.8	2757.3	
2/24	8:30	176.1	209.7	217.1	51.2	654.2	903.4	1076.0	1113.9	262.8	3356.0	
	11:00	176.1	209.7	217.1	51.2	654.2	903.4	1076.0	1113.9	262.8	3356.0	Average in g/min 3356.0
	13:00	176.1	209.7	217.1	51.2	654.2	903.4	1076.0	1113.9	262.8	3356.0	

^a Reading in mL/min = (Flowmeter reading mL/min * slope) + y intercept.

Slope and intercept were obtained for initial day that the flowmeters were calibrated.

^b Concentration in g/min = density in g/mL x mL/min [Density of SF₆ = 5.13 g/mL].

^c See Figures 4-4 and 4-5 for rotameter site locations.

P_a	=	actual barometric pressure (mm Hg) = 1.006 P_{sta} ;
P_{sta}	=	station pressure for Bush field (mm Hg);
1.006	=	altitude correction for Bush field;
T_a	=	actual absolute temperature (K) = °C + 273; and
P_r	=	reference atmospheric pressure = 760.7 mm Hg.

To obtain the value of T_a in Equation 4-2, the temperature data obtained from the roof vent meteorological station were used, where available. However, for time periods when actual monitoring was not conducted, the available data were analyzed separately to estimate the vent air temperature.

To estimate roof vent air temperature, the available monitoring data were copied into a separate spreadsheet and the difference between the vent temperature and the ambient temperature calculated for each 15-min averaging period. The temperature differentials (ΔT s) obtained from these calculations were then plotted on the same graph as a series of daily time histories. Upon examination of these plots, a similar daily trend in ΔT was observed, as would be expected for a naturally ventilated building. Appropriate averages were then calculated from the 15-min monitoring results which were subsequently applied to the ambient temperature data for those time periods where actual monitoring was not conducted. The time histories generated from the monitoring results and the average daily ΔT cycle calculated from these data are shown in Figures 4-6a and 4-6b, respectively. As shown by Figure 4-6b, the “artificial” chronology developed from the average data is very similar to the daily trends actually determined from the monitoring results (Figure 4-6a) and thus should be adequate to estimate vent air temperature.

Finally, the concentration, velocity, temperature, and pressure data described above were imported into an Excel[®] spreadsheet and the Hg^0 emission rate calculated for each 1-min averaging period using Equations 4-1 and 4-2. Also generated in the spreadsheet were summary statistics and a time history for each 24-hr period. A copy of this spreadsheet is provided in Appendix F.

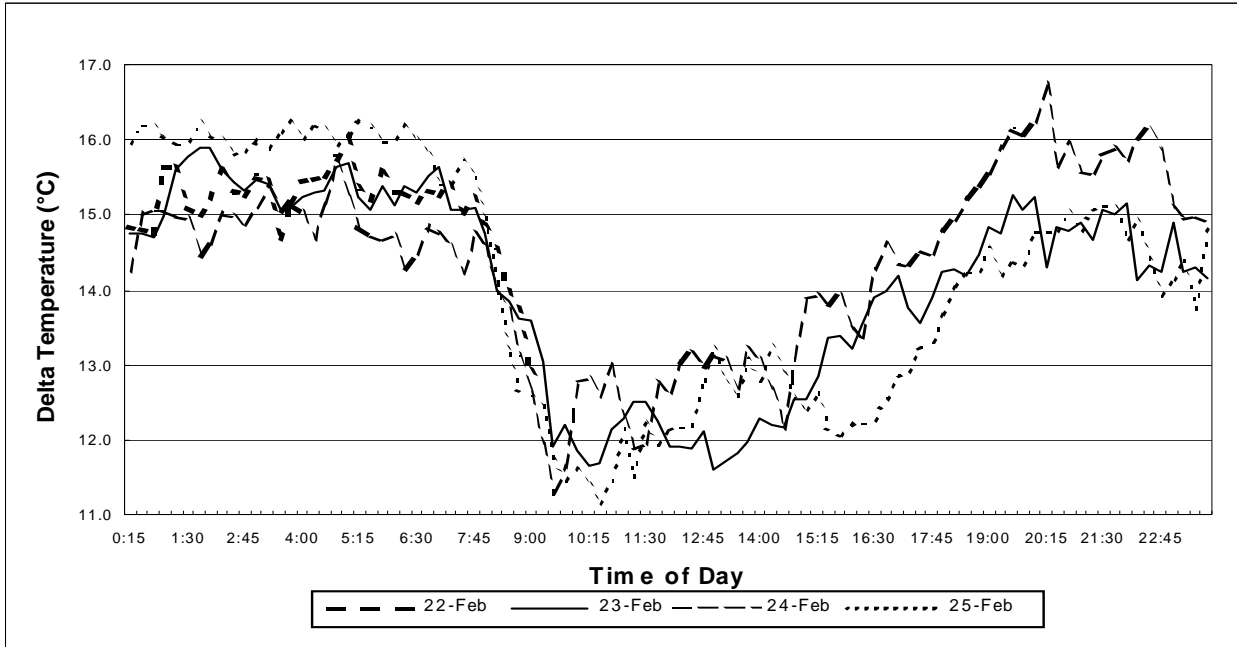

Figure 4-6a. Average roof vent temperature differential as determined from 15-min monitoring data.

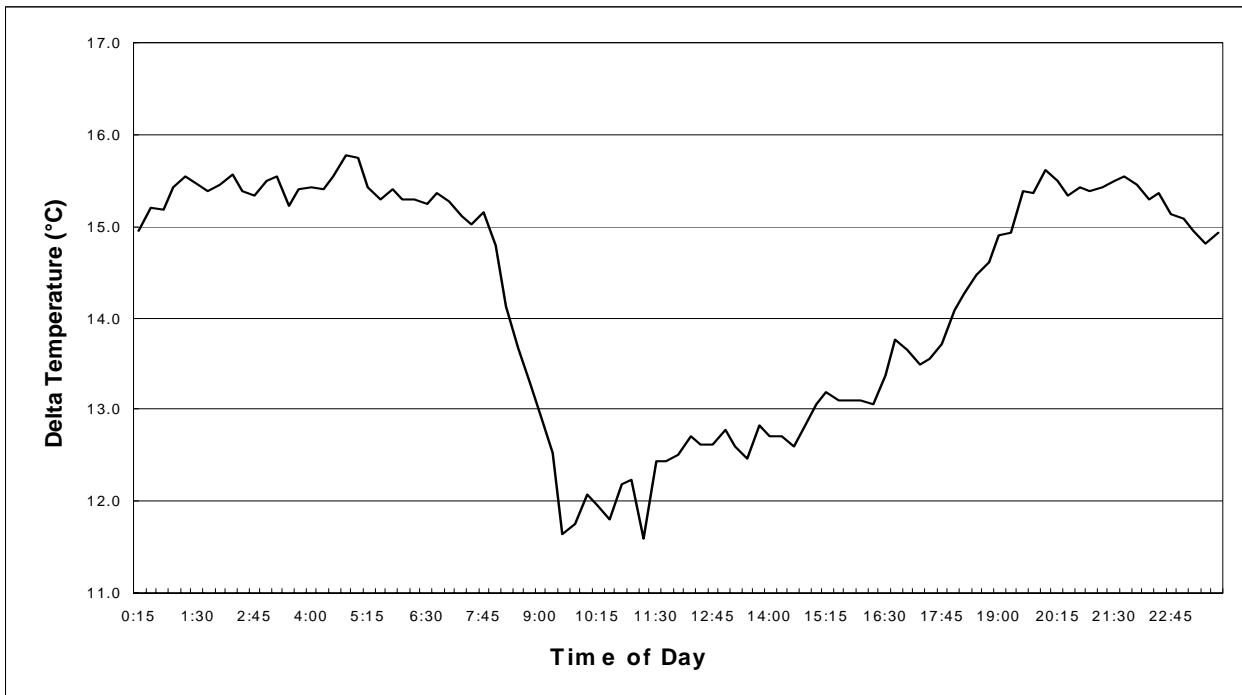

Figure 4-6b. Calculated temperature differential for roof ventilator as determined from average monitoring data shown in Figure 4-6a.

4.2.4 Manual Velocity Measurements and Flow Balance Calculations

For the manual velocity measurements in the roof vent, the data from the field notebook were entered by hand into an Excel® spreadsheet (Appendix D). These data were then plotted with respect to the physical boundaries of the ventilator throat and averages calculated for each set of observations. The averages were then compared to similar values obtained from the optical anemometer for the same time period. In addition, the data points obtained at both edges of the ventilator were extrapolated by linear regression to the point of zero velocity. These locations were then used to determine the effective flow area of the vent (A_e) for the emission rate calculations shown in Equation 4-1 above.

In the case of the building openings, the manual velocity data were also entered by hand into an Excel® spreadsheet (Appendix E). These values were then multiplied by the cross sectional area of each opening as determined either from building drawings or field notes to determine volumetric flow rate. The individual flow rates were then combined with the total volumetric flow of the electrically powered ventilation fans to obtain the total ambient air entering the cell building. Similar calculations were also performed for the roof vent using the applicable optical anemometer data for the same measurement period and the effective flow area as described earlier.

To perform the flow balance for the building, three separate techniques were used. The first technique simply corrected the total flow obtained for the building inlets and roof vent to standard temperature and pressure and compared the two values on a volumetric basis. In the second method, the mass of air entering and leaving the building was calculated and a similar comparison made. Finally, a method developed by the Occidental Chemical Corporation (OxyChem) as part of their direct mass balance (DMB) modeling effort was also used. For the sake of consistency, all flow balance calculations were performed in English units as described in the following paragraphs.

In the first approach, the total flow for both the building inlets and the roof vent was corrected to a standard temperature of 77 °F (25 °C) and pressure of 29.92 in. Hg (760 mm Hg) according to:

$$Q_s = Q_a \frac{T_s P_a}{T_a P_s} \quad (4-3)$$

Where:

Q_s	=	volumetric flow rate at standard conditions (ft ³ /min);
Q_a	=	volumetric flow rate at actual conditions (ft ³ /min);
T_s	=	standard absolute temperature (537 °R);
T_a	=	actual absolute temperature: (°R) = °F + 460;
P_a	=	actual barometric pressure (in. Hg) = 1.006 P_{sta} ;
P_{sta}	=	station pressure for Bush field (in. Hg);
1.006	=	altitude correction for Bush field; and
P_s	=	standard atmospheric pressure = 29.92 in. Hg.

As shown by Equation 4-3 above, no correction for relative humidity (water vapor) was made in the calculations.

Percent closure of the volume balance was then calculated as:

$$\% \text{ Balance} = 100 - \left[\left(\frac{Q_{in} - Q_{out}}{Q_{in}} \right) * 100 \right] \quad (4-4)$$

Where:

Q_{in}	=	volumetric air flow entering the cell building (standard ft ³ /min); and
Q_{out}	=	volumetric air flow exiting the roof ventilator (standard ft ³ /min).

In the second calculation scheme, a traditional mass balance was performed which compared the quantity of air entering the building through the various openings to that exiting the roof vent per unit time. For these calculations, the partial pressure of water vapor in moist air (p_w) at the building inlet and outlet was found by (ASHRAE, 1981):

$$p_w = \phi p_s \quad (4-5)$$

Where:

p_w	=	partial pressure of water vapor in moist air (in. Hg/in. ²);
ϕ	=	relative humidity (expressed as a fraction); and
p_s	=	vapor pressure of water in moist air at saturation (in. Hg/in. ²).

Equation 4-5 assumes that p_w is approximately equal to the vapor pressure of saturated pure water (p_{ws}) which is generally accepted for most calculations (ASHRAE, 1981).

Next, the volume of moist air per unit mass of dry air (v) was found for the air entering and leaving the building by (ASHRAE, 1981):

$$v = \frac{R_a T}{(p - p_w)} \quad (4-6)$$

Where:

- v = volume of moist air per unit mass of dry air (ft^3 of mixture/ lb_m dry air);
- R_a = ideal gas constant for dry air ($\text{in. Hg/in.}^2 \cdot \text{lb}_m^{-1} \cdot \text{°R}^{-1}$);
- lb_m = pound mass of air (engineering units);
- T = absolute temperature (°R);
- p = barometric pressure (in. Hg/in.^2); and
- p_w = partial pressure of water vapor in moist air (in. Hg/in.^2) from Equation 4-5.

The mass of air either entering or leaving the building per unit of time was then calculated according to Equation 4-7:

$$M = \frac{V}{v} \quad (4-7)$$

Where:

- M = mass of dry air per unit time (lb_m/min);
- V = volumetric flow rate (ft^3/min); and
- v = volume of moist air per unit mass of dry air (ft^3 of mixture/ lb_m dry air) from Equation 4-6.

To assess the percent closure of the mass balance, Equation 4-8 was used:

$$\% \text{ Balance} = 100 - \left[\left(\frac{M_{\text{in}} - M_{\text{out}}}{M_{\text{in}}} \right) * 100 \right] \quad (4-8)$$

Where:

$$\begin{aligned} M_{\text{in}} &= \text{mass of dry air per unit time entering the building (lb}_m\text{/min)} \\ M_{\text{out}} &= \text{mass of dry air per unit time exiting the building (lb}_m\text{/min)} \end{aligned}$$

Finally, the field data were entered into a special Excel[®] spreadsheet developed by Michael Shaffer of OxyChem's Delaware City plant. This spreadsheet uses a slightly different approach to performing the mass balance which was adopted as an independent check on the calculations described above.

SECTION 5 RESULTS AND DISCUSSION

This section provides the results of the Olin field study as obtained using the equipment, methods, and data analysis procedures described in Section 4. Also included in this section is a discussion of key experimental results.

5.1 Mercury Monitoring Results

The outcome of the roof vent monitoring conducted at the Olin cell building is discussed below. Both the Hg⁰ emission rates calculated from the continuous monitoring data as well as comparisons of the UV-DOAS results to other Hg⁰ measurement techniques are also described.

5.1.1 Monitoring Data and Mercury Emission Rates

As discussed above, continuous monitoring was conducted at the roof vent for Hg⁰ concentration and air velocity from which 1-minute average Hg⁰ emission rates were calculated. In addition, continuous monitoring was also attempted for SF₆ tracer gas as a separate measure of the air flow rate from the vent. The results of these measurements are discussed below.

The raw 30-sec averages generated by the UV-DOAS were reduced to produce daily plots of the Hg⁰ monitoring results as well as summary statistics for each day. The daily data plots are shown in Figures 5-1 to 5-9 with summary statistics calculated from the data provided in Table 5-1. As can be seen from Table 5-1, the measured Hg⁰ concentration varied over an order of magnitude from ~ 73 to 7.3 μg/m³. The overall average for the study period was 24 μg Hg⁰/m³.

Similar plots and statistics were also created from analysis of the 1-min optical anemometer data as discussed in Section 4.1.1. The plots are shown in Figures 5-10 to 5-18 with summary statistics for each daily data set provided in Table 5-2. As shown in Table 5-2, the air velocities measured by the

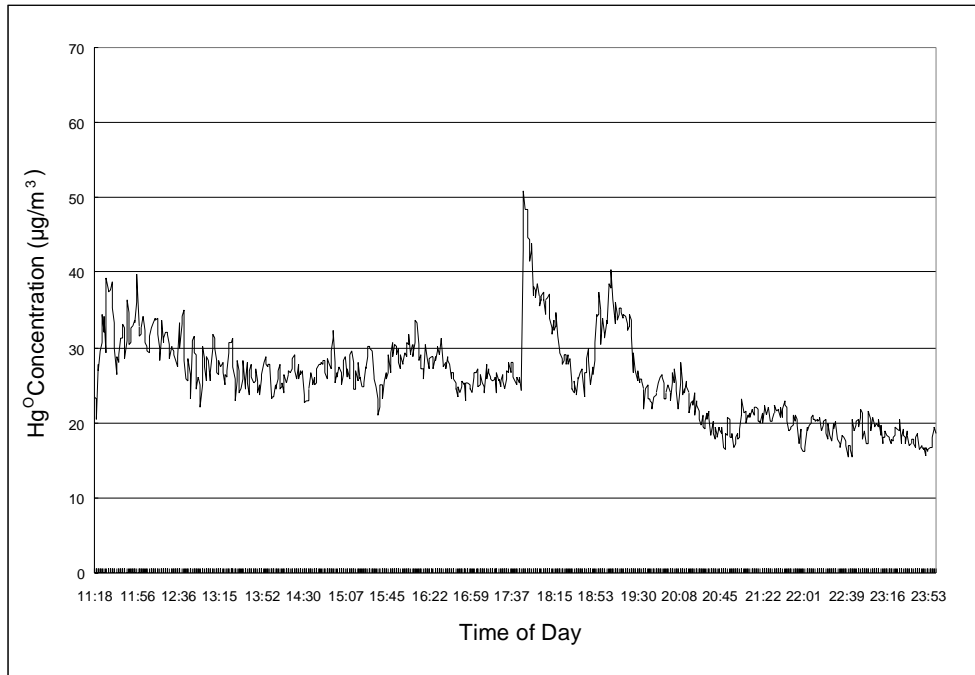

Figure 5-1. Time history of roof vent elemental mercury concentration for February 17, 2000.

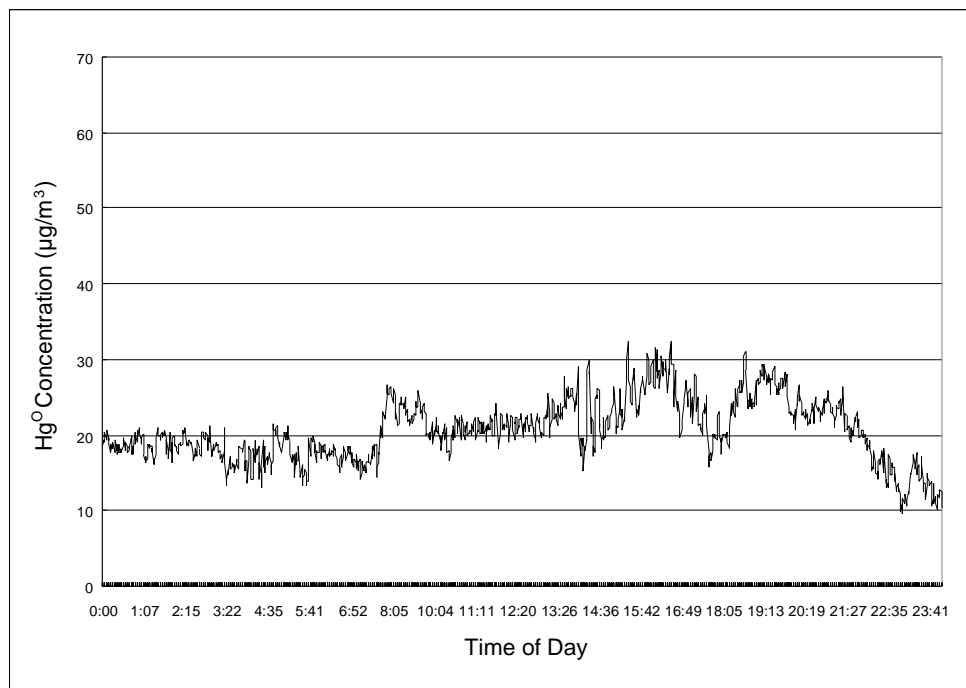

Figure 5-2. Time history of roof vent elemental mercury concentration for February 18, 2000.

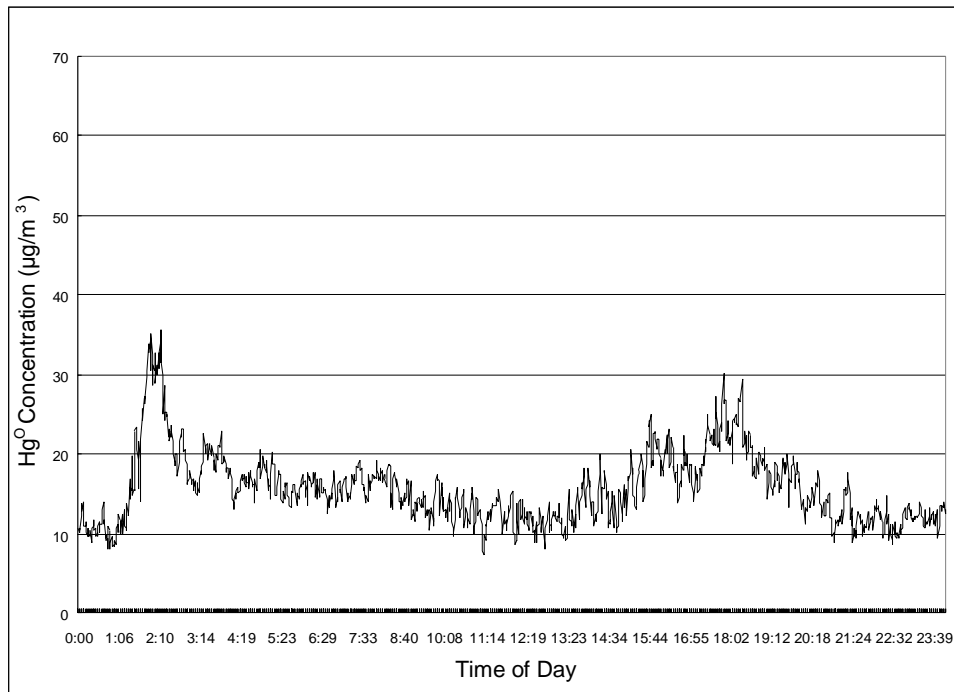

Figure 5-3. Time history of roof vent elemental mercury concentration for February 19, 2000.

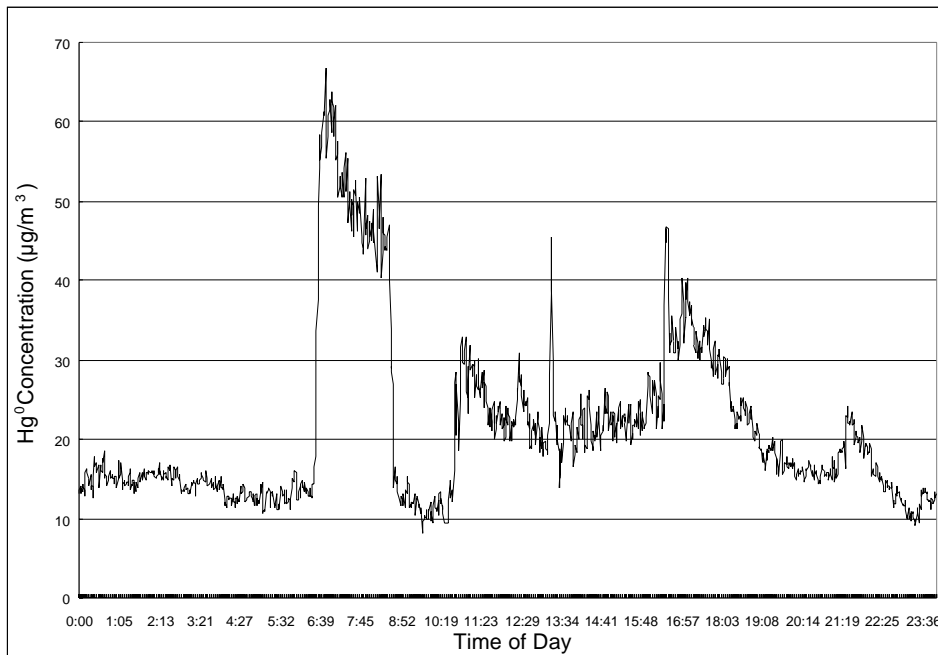

Figure 5-4. Time history of roof vent elemental mercury concentration for February 20, 2000.

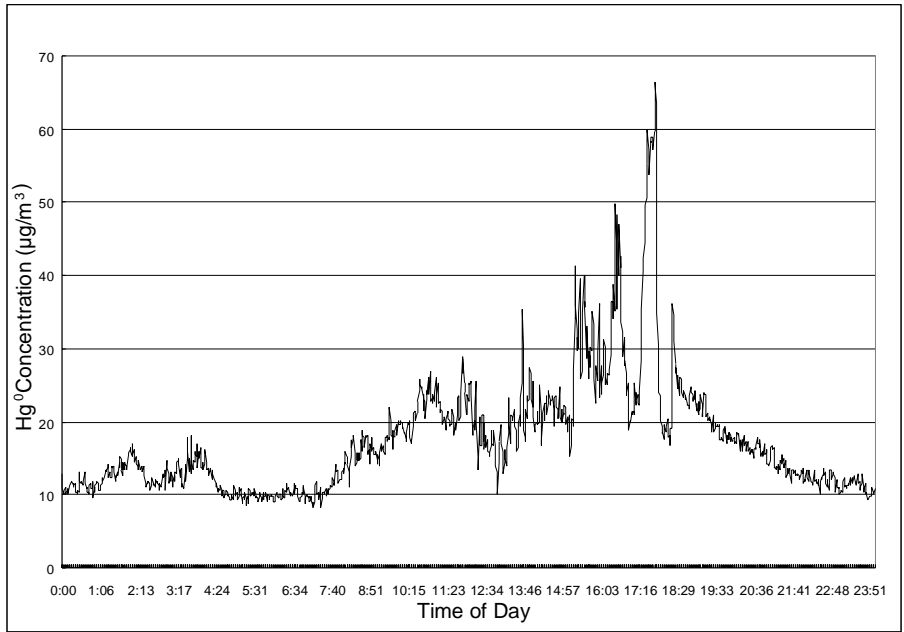

Figure 5-5. Time history of roof vent elemental mercury concentration for February 21, 2000.

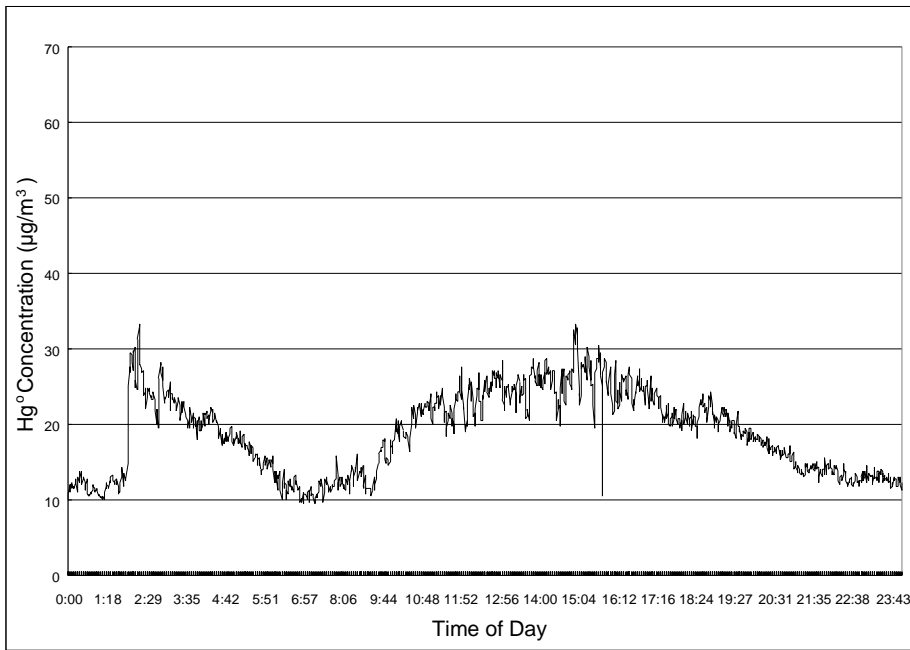

Figure 5-6. Time history of roof vent elemental mercury concentration for February 22, 2000.

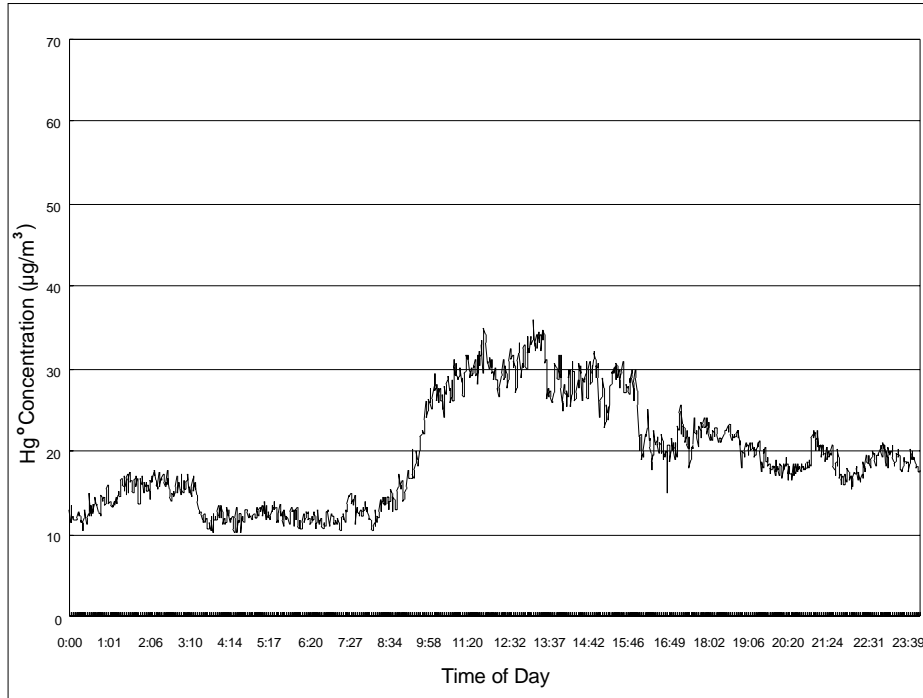

Figure 5-7. Time history of roof vent elemental mercury concentration for February 23, 2000.

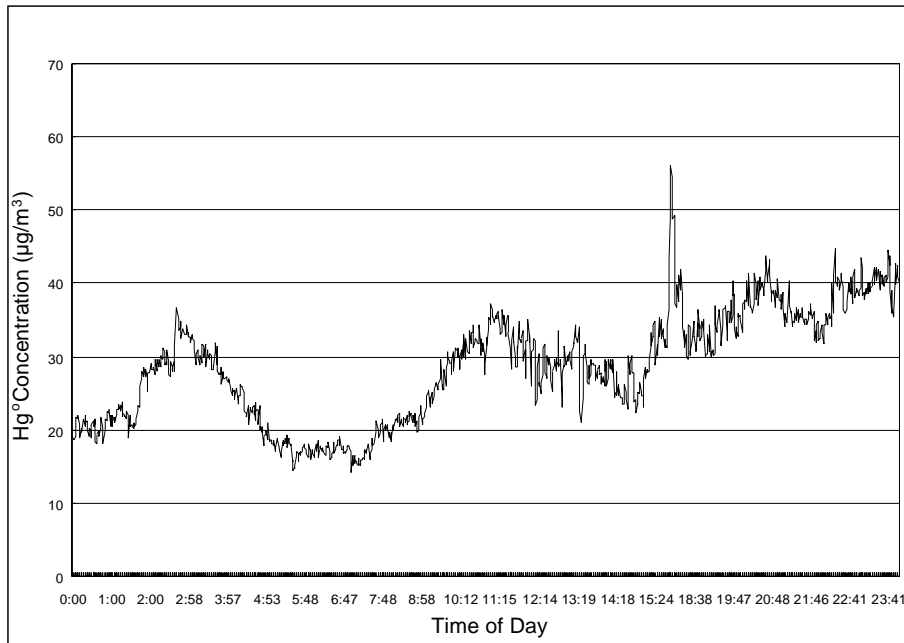

Figure 5-8. Time history of roof vent elemental mercury concentration for February 24, 2000.

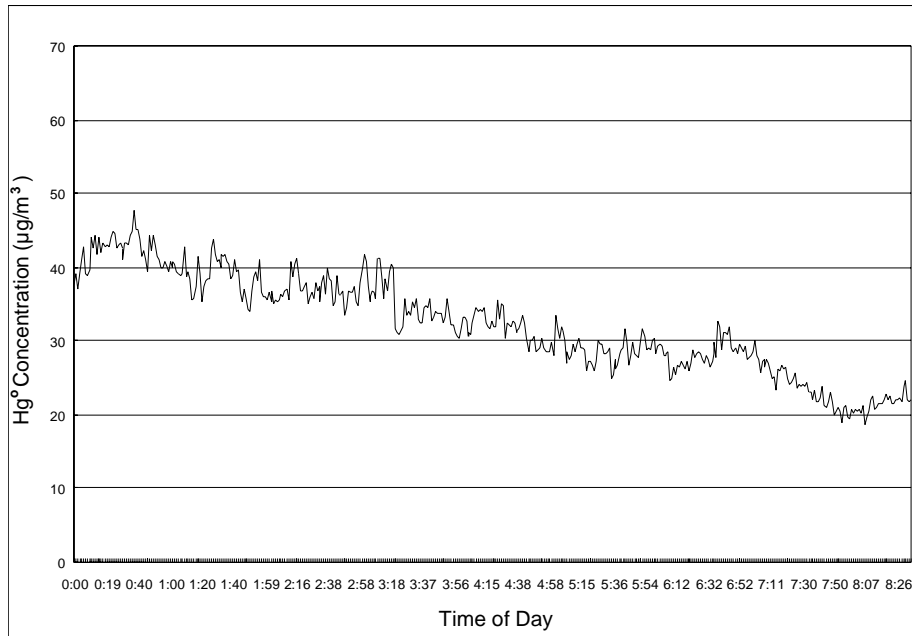

Figure 5-9. Time history of roof vent elemental mercury concentration for February 25, 2000.

Table 5-1. Summary of 30-sec Roof Vent DOAS Data^a

Date	Hg ⁰ Concentration (µg/m ³) ^a			Standard Deviation	No. of Observations (n) ^b	% Completeness ^b
	Maximum	Minimum	Mean			
2/17/00	56.6	15.5	27.4	6.01	1281	89
2/18/00	35.5	10.2	22.1	4.33	2553	89
2/19/00	38.8	7.32	16.8	4.83	2549	89
2/20/00	73.0	8.49	23.0	11.9	2553	89
2/21/00	71.3	8.43	19.0	9.00	2555	89
2/22/00	36.6	7.83	20.0	5.97	2544	88
2/23/00	40.0	10.5	21.2	7.03	2546	88
2/24/00	62.7	15.3	30.7	8.15	2317	80
2/25/00	51.1	19.3	34.7	7.13	922	89
Mean	51.7	11.4	23.9	---	---	88

^a At 30 °C and 29.95 in. Hg. Three significant figures.

^b Dimensionless. Target value $\geq 75\%$.

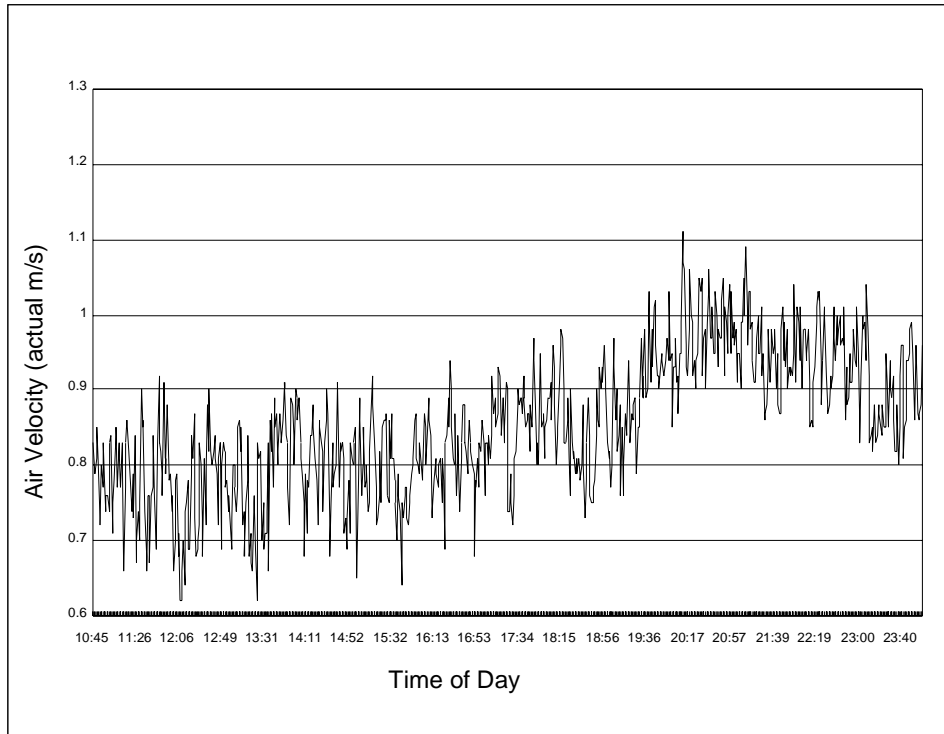

Figure 5-10. Time history of roof vent air velocity for February 17, 2000.

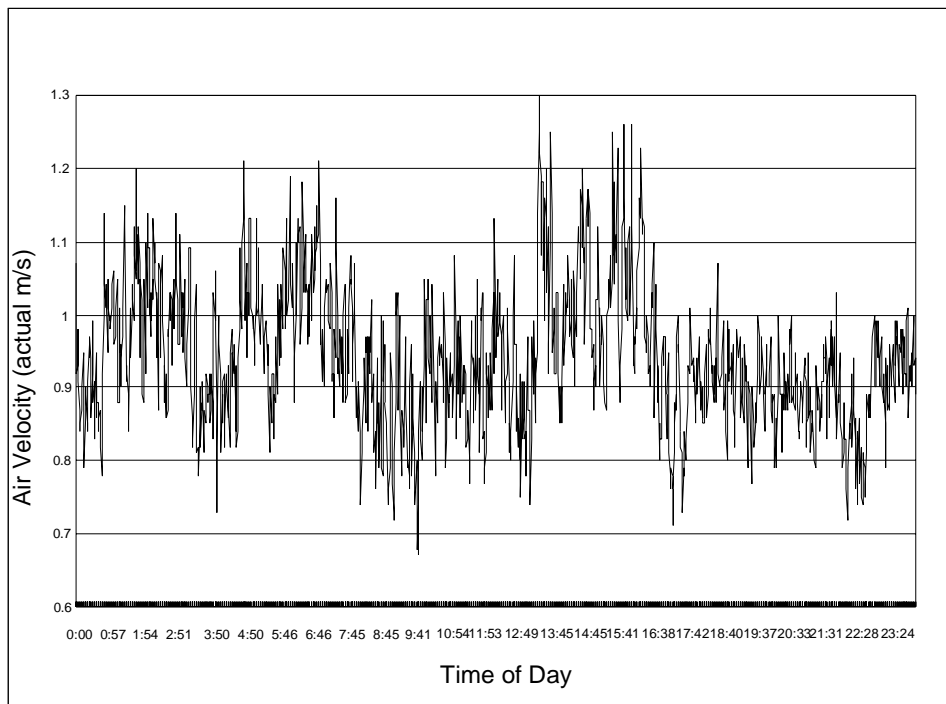

Figure 5-11. Time history of roof vent air velocity for February 18, 2000.

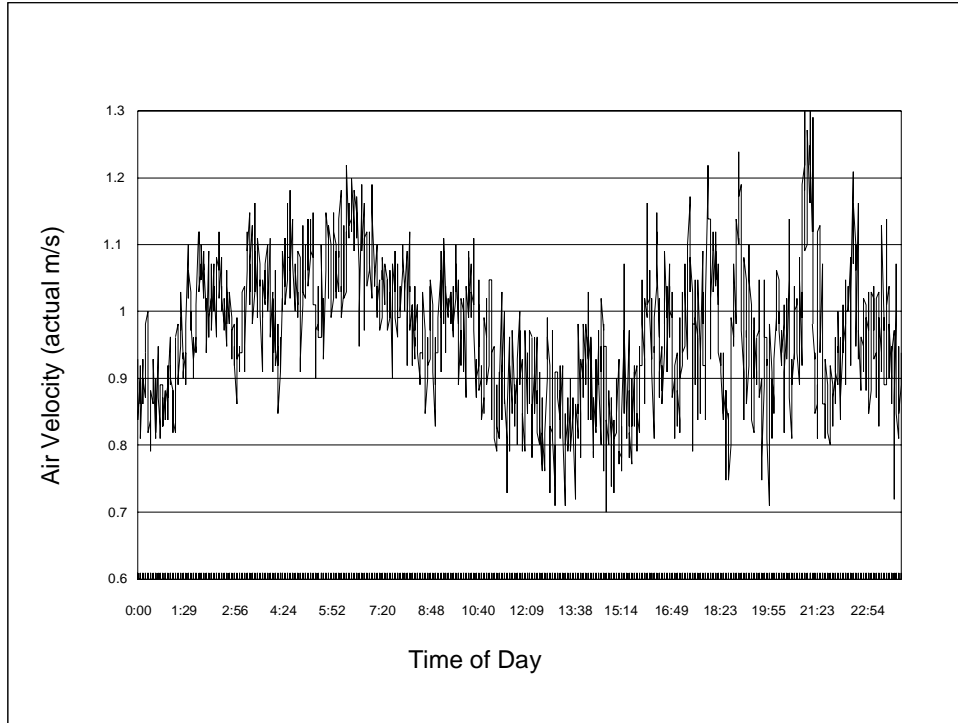

Figure 5-12. Time history of roof vent air velocity for February 19, 2000.

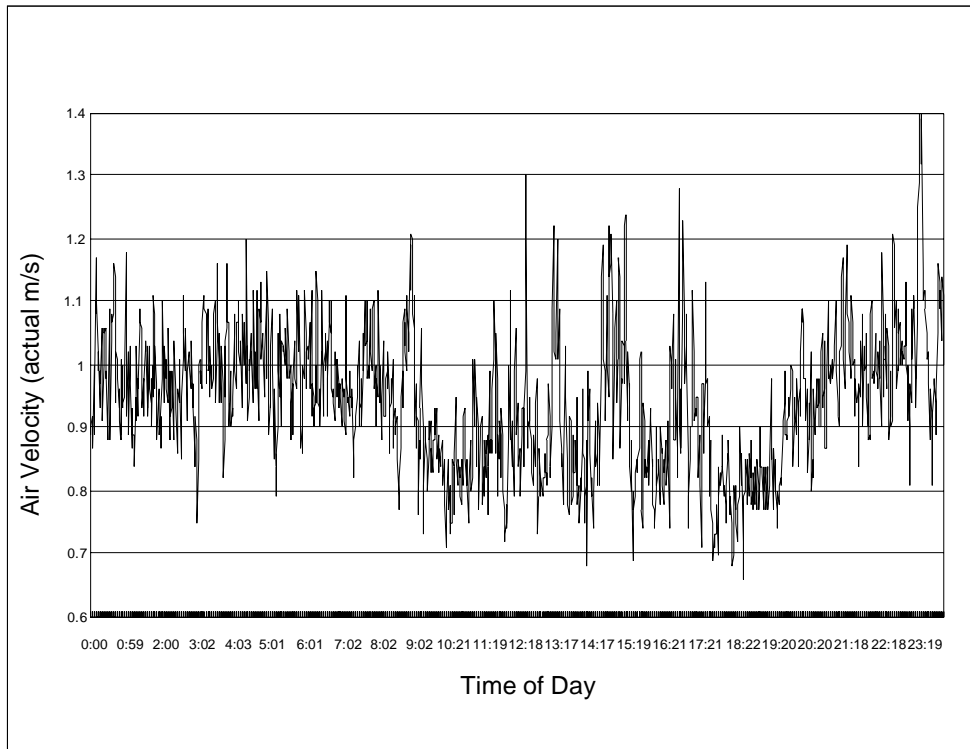

Figure 5-13. Time history of roof vent air velocity for February 20, 2000.

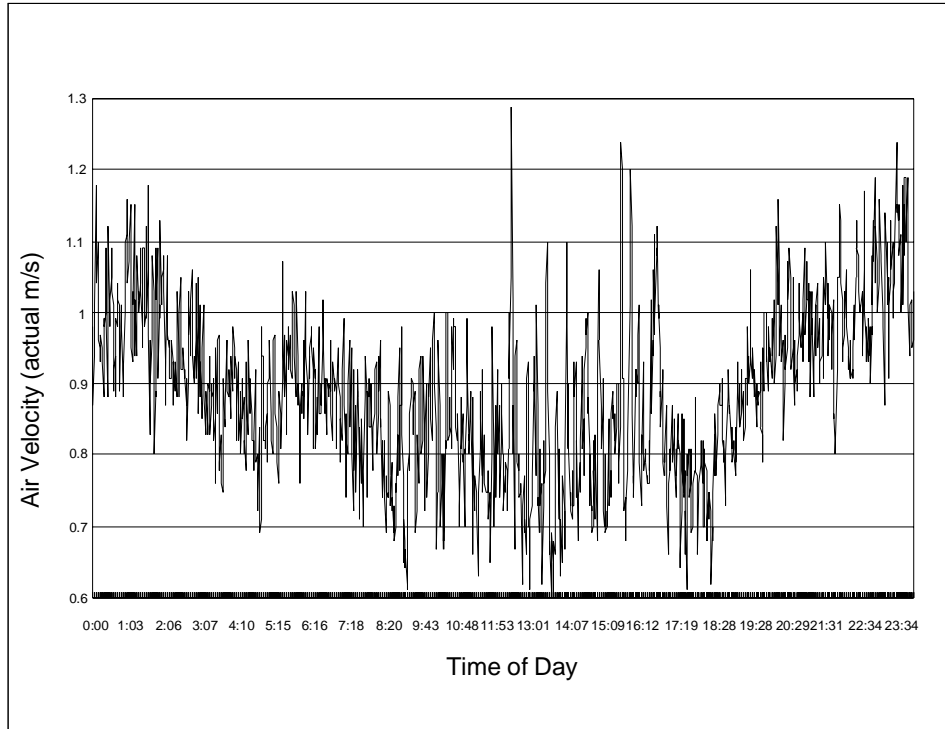

Figure 5-14. Time history of roof vent air velocity for February 21, 2000.

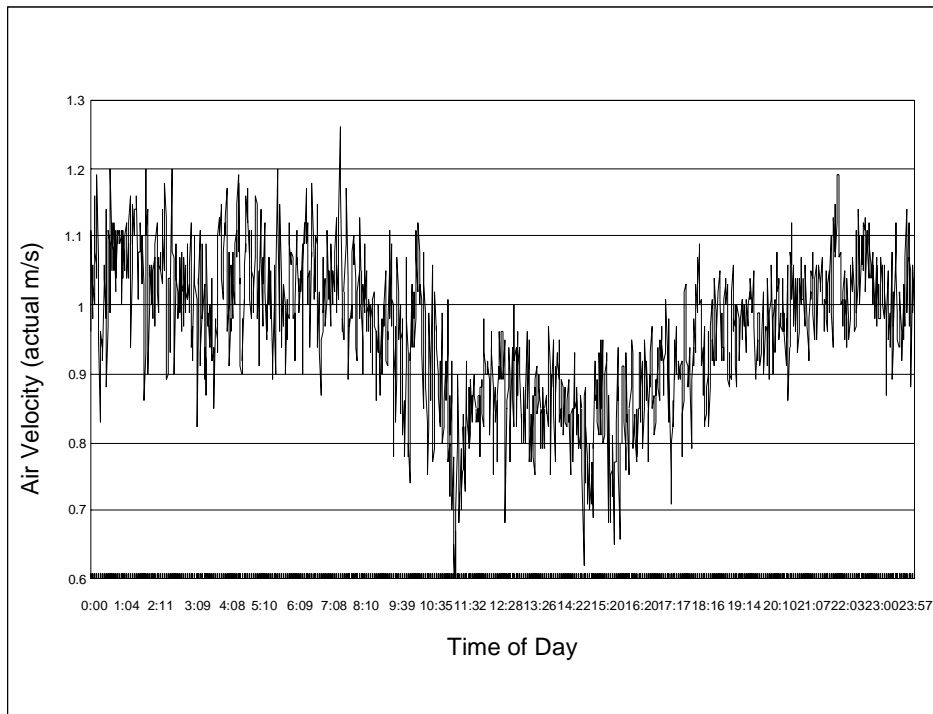

Figure 5-15. Time history of roof vent air velocity for February 22, 2000.

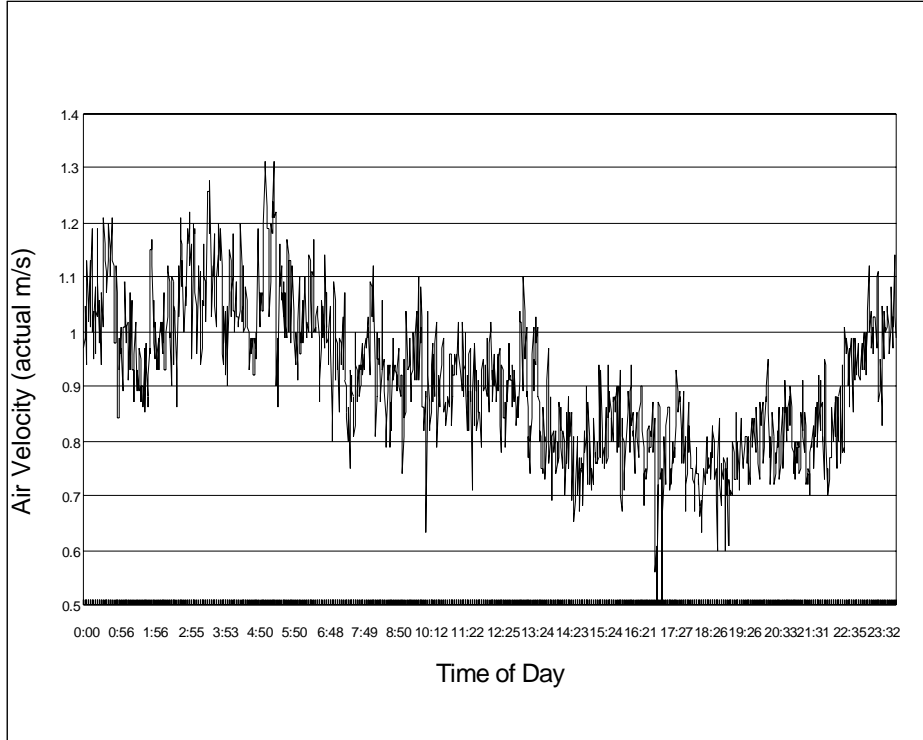

Figure 5-16. Time history of roof vent air velocity for February 23, 2000.

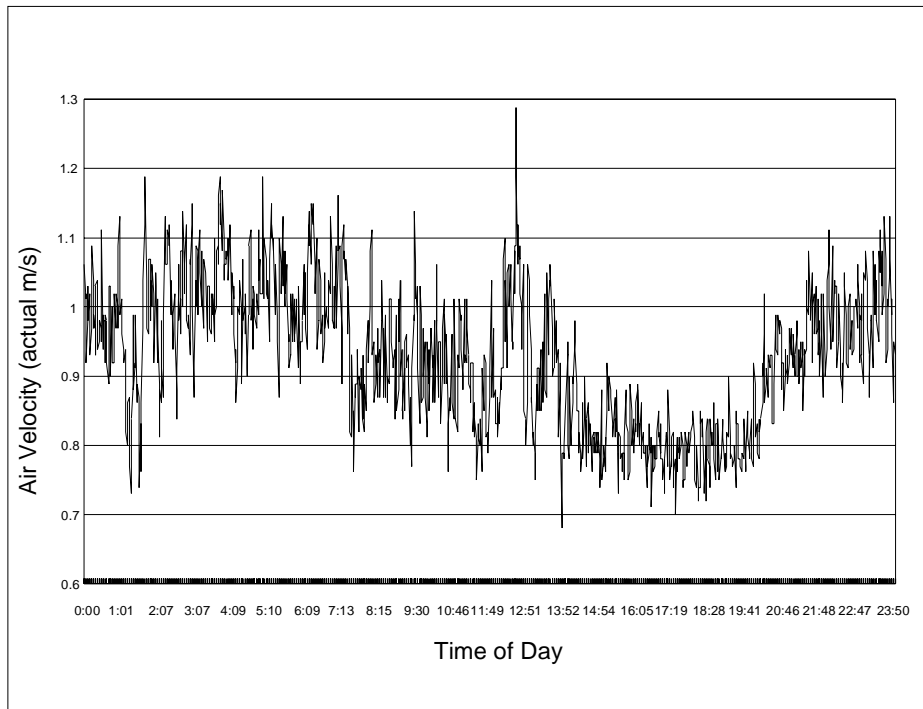

Figure 5-17. Time history of roof vent air velocity for February 24, 2000.

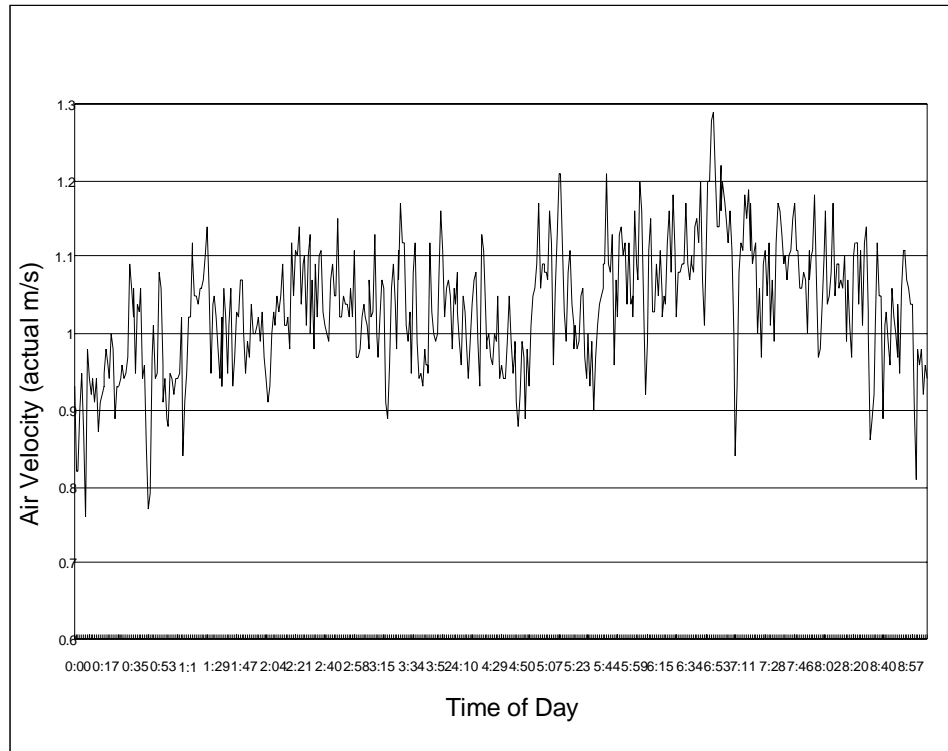

Figure 5-18. Time history of roof vent air velocity for February 25, 2000.

Table 5-2. Summary of 1-min Roof Vent Optical Anemometer Data^a

Date	Air Velocity (m/s)			Standard Deviation	No. of Observations (n) ^b	% Completeness ^b
	Maximum	Minimum	Mean			
2/17/00	1.1	0.62	0.85	0.091	780	98
2/18/00	1.3	0.67	0.94	0.10	1380	96
2/19/00	1.3	0.70	0.97	0.10	1367	95
2/20/00	1.5	0.66	0.94	0.11	1372	95
2/21/00	1.3	0.58	0.89	0.12	1323	92
2/22/00	1.3	0.51	0.96	0.10	1347	94
2/23/00	1.3	0.24	0.91	0.13	1314	91
2/24/00	1.3	0.68	0.93	0.10	1264	88
2/25/00	1.3	0.76	1.0	0.083	492	90
Mean	1.3	0.60	0.93	--	--	93

^a Measured at actual vent temperature and pressure. Two significant figures.

^b Dimensionless. Target value = 90%.

optical anemometer varied from 0.24 to 1.5 m/s with an overall average for the monitoring period of 0.94 m/s.

The 1-min average Hg^0 emission rates calculated from the monitoring data are plotted in Figures 5-19 to 5-27 for the 9-day study period. Summary statistics calculated from these data are shown in Table 5-3. As indicated by Table 5-3, the Hg^0 emission rate varied over about 2 orders of magnitude from 0.08 to 1.2 g/min. An overall average Hg^0 emission rate for the monitoring period of 0.36 g/min was also calculated from the data.

5.1.2 Comparison of Mercury Measurement Methods

In addition to the continuous monitoring described above, the UV-DOAS results were also compared to other measurement techniques performed by collaborators from the Oak Ridge National Laboratory (ORNL). Each comparison is described below along with the results obtained.

In the first analysis, a comparison was made between the concentration of Hg^0 measured by the UV-DOAS and similar measurements conducted using a hand-held instrument at various points across the width of the roof vent (i.e., from north to south). This comparison was made to determine whether any stratification in the Hg^0 concentration was evident across the width of the vent. The hand-held measurements were made by ORNL using a Jerome Model 431-X survey instrument. (Note that the Model 431-X uses an electrical resistance cell to measure Hg^0 , and thus the readings are not directly comparable to an optical method such as the UV-DOAS. Also, the lower detection limit of the Jerome is 3000 ng/m^3 as compared to $\sim 130 \text{ ng/m}^3$ for the DOAS.) The data obtained from this evaluation are summarized graphically in Figure 5-28.

As shown by Figure 5-28, the Hg^0 concentrations determined by the Jerome instrument were relatively consistent across the width of the vent and compare reasonably well to the average concentration obtained with the UV-DOAS. Based on these results, the measurements made by the UV-DOAS were considered to be representative of the entire vent cross section and thus useful for the purpose of the emission rate calculations.

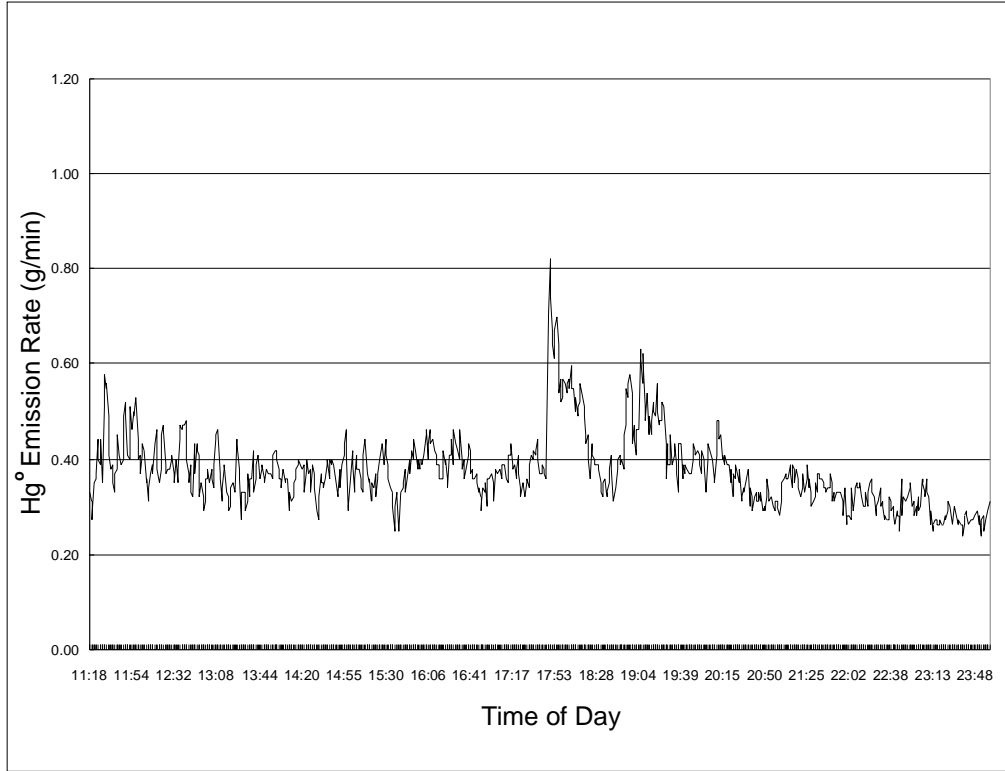

Figure 5-19. Elemental mercury emission rates for February 17, 2000.

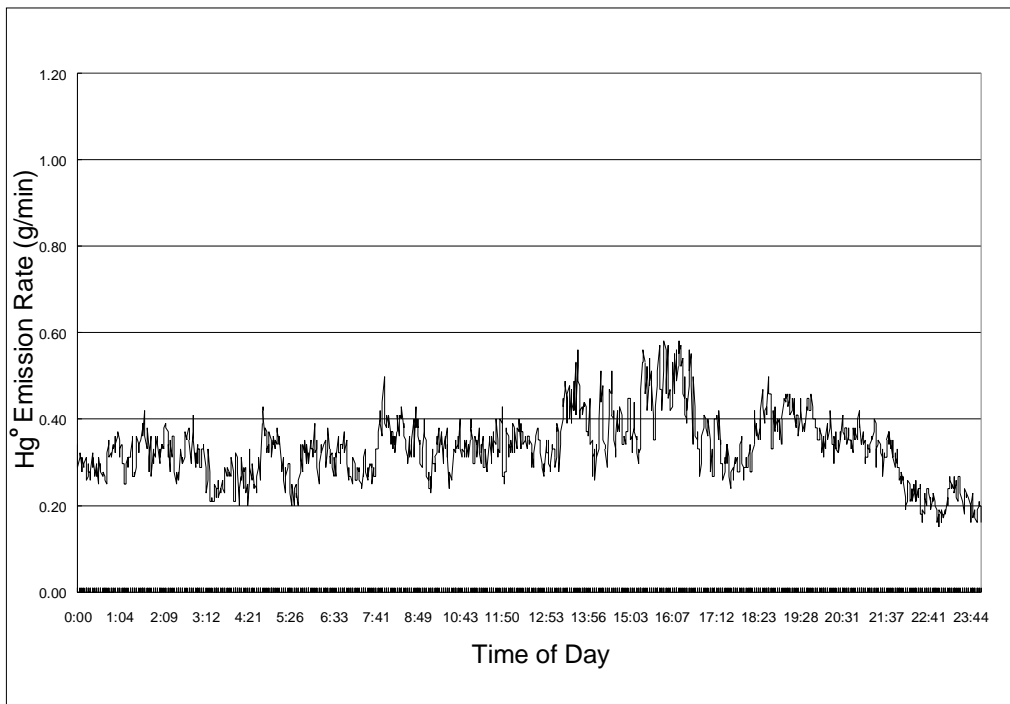

Figure 5-20. Elemental mercury emission rates for February 18, 2000.

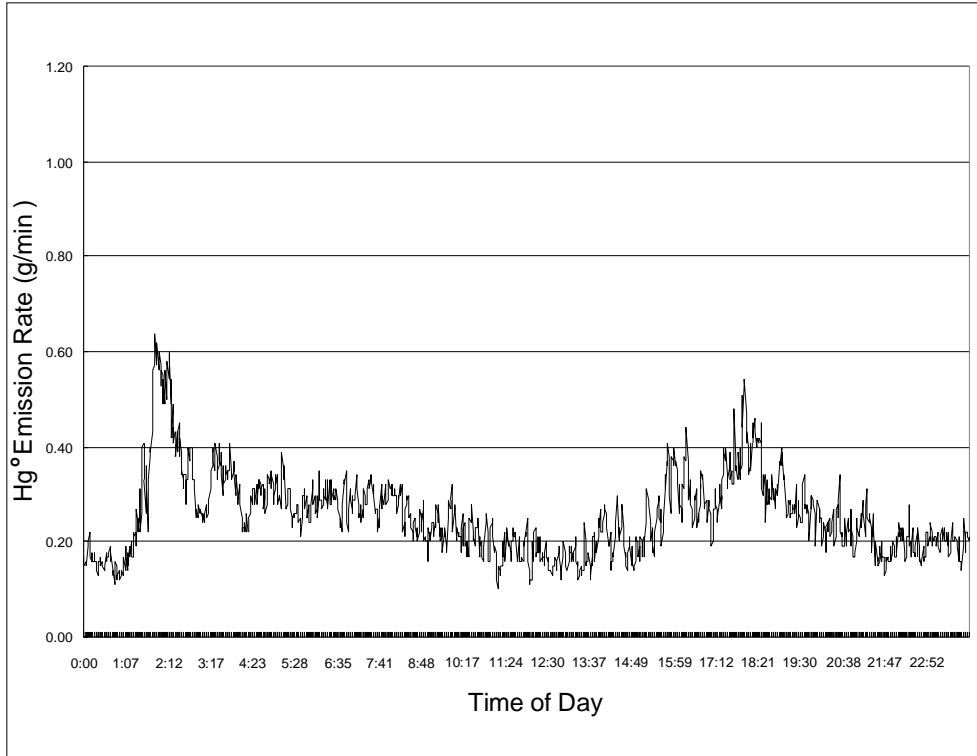

Figure 5-21. Elemental mercury emission rates for February 19, 2000.

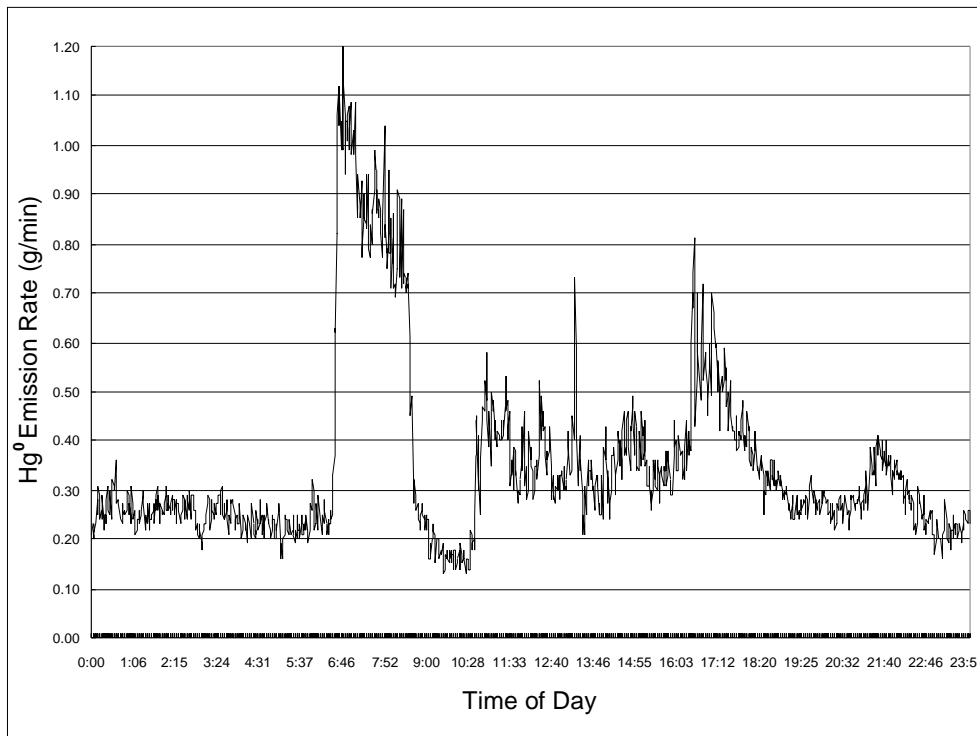

Figure 5-22. Elemental mercury emission rates for February 20, 2000.

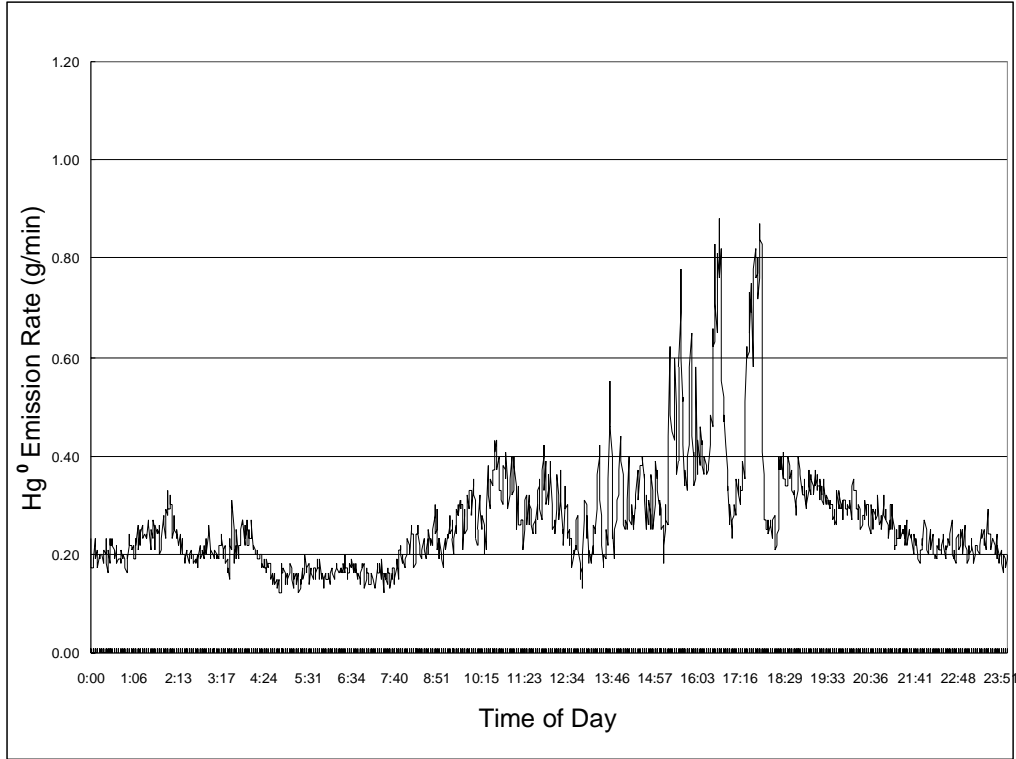

Figure 5-23. Elemental mercury emission rates for February 21, 2000.

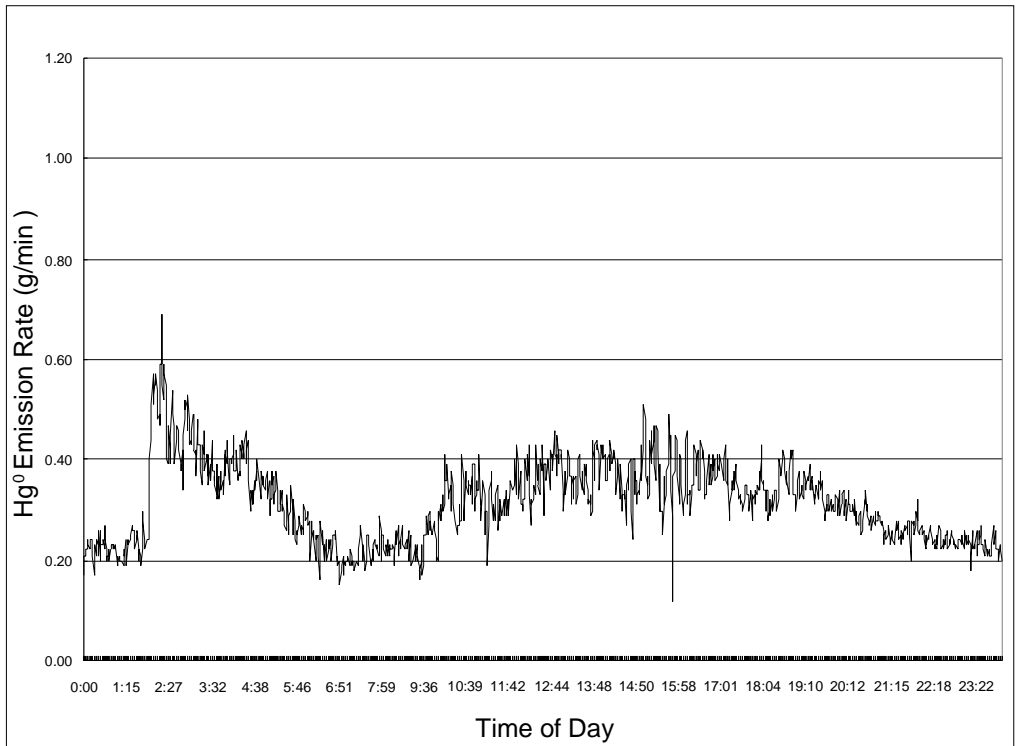

Figure 5-24. Elemental mercury emission rates for February 22, 2000.

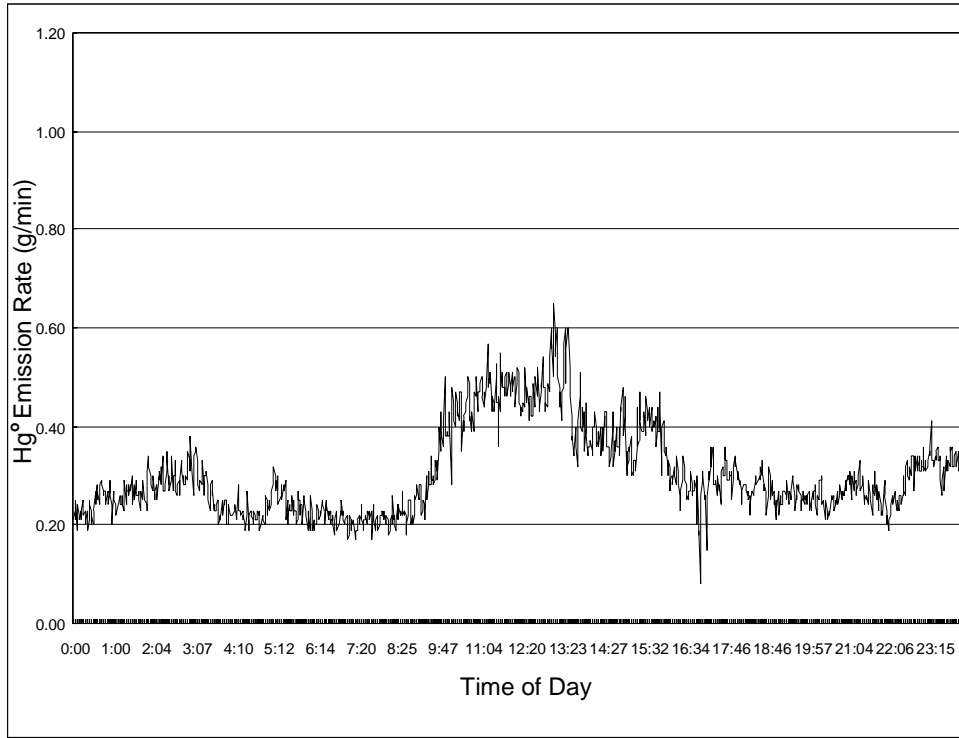

Figure 5-25. Elemental mercury emission rates for February 23, 2000.

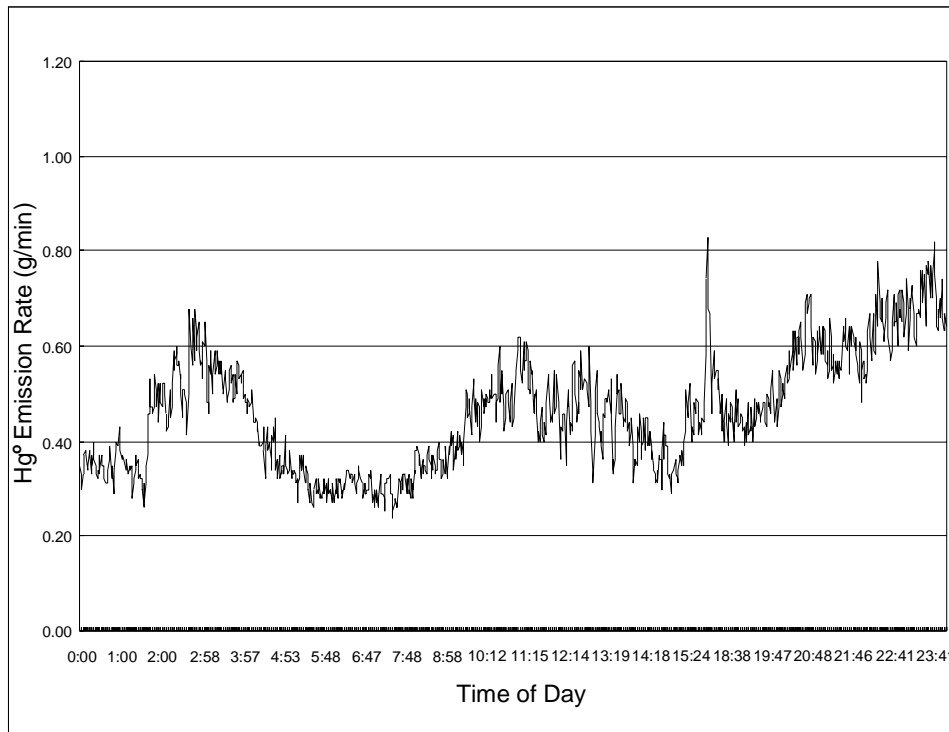

Figure 5-26. Elemental mercury emission rates for February 24, 2000.

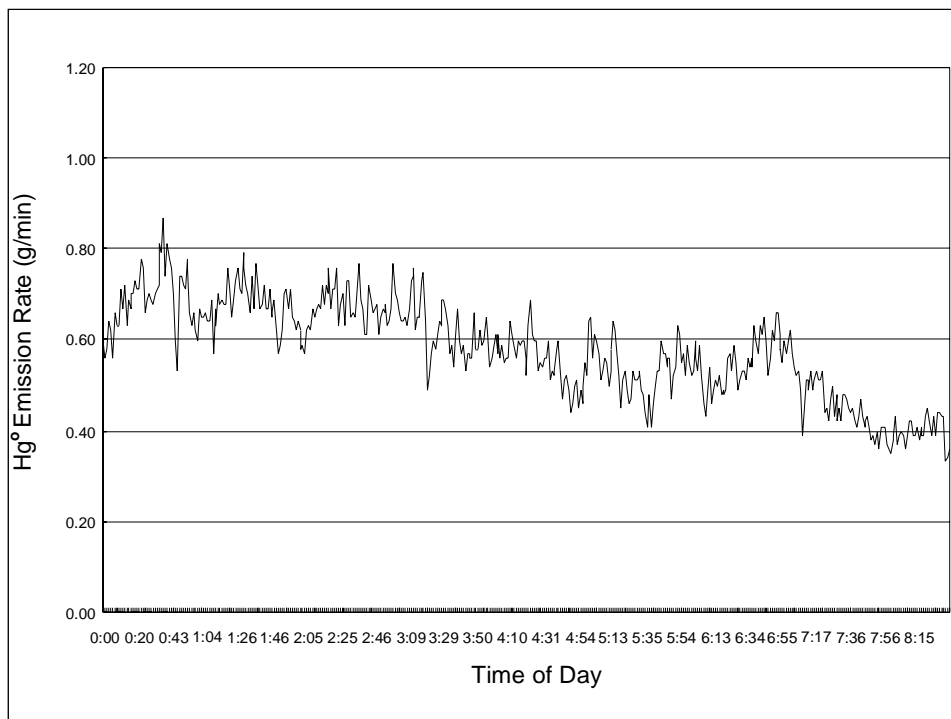

Figure 5-27. Elemental mercury emission rates for February 25, 2000.

Table 5-3. Summary of Calculated Elemental Mercury Emission Rates^a

Date	Hg ⁰ Emission Rate (g/min)				No. of Observations ^b	Total Daily Emissions (g/day) ^c
	Maximum	Minimum	Mean	Standard Deviation		
2/17/00	0.82	0.24	0.38	0.076	747	N/A
2/18/00	0.58	0.15	0.33	0.075	1339	481
2/19/00	0.64	0.10	0.26	0.085	1364	370
2/20/00	1.2	0.13	0.35	0.19	1368	510
2/21/00	0.88	0.12	0.27	0.11	1311	387
2/22/00	0.69	0.12	0.31	0.080	1340	453
2/23/00	0.65	0.080	0.30	0.090	1300	438
2/24/00	0.83	0.24	0.46	0.12	1130	662
2/25/00	0.87	0.33	0.58	0.11	450	N/A
Mean	0.80	0.17	0.36	---	---	472

^a Two significant figures.

^b Dimensionless.

^c Sum of measured 1-min values adjusted to standard day of 1440 min to account for missing data.

Three significant figures.

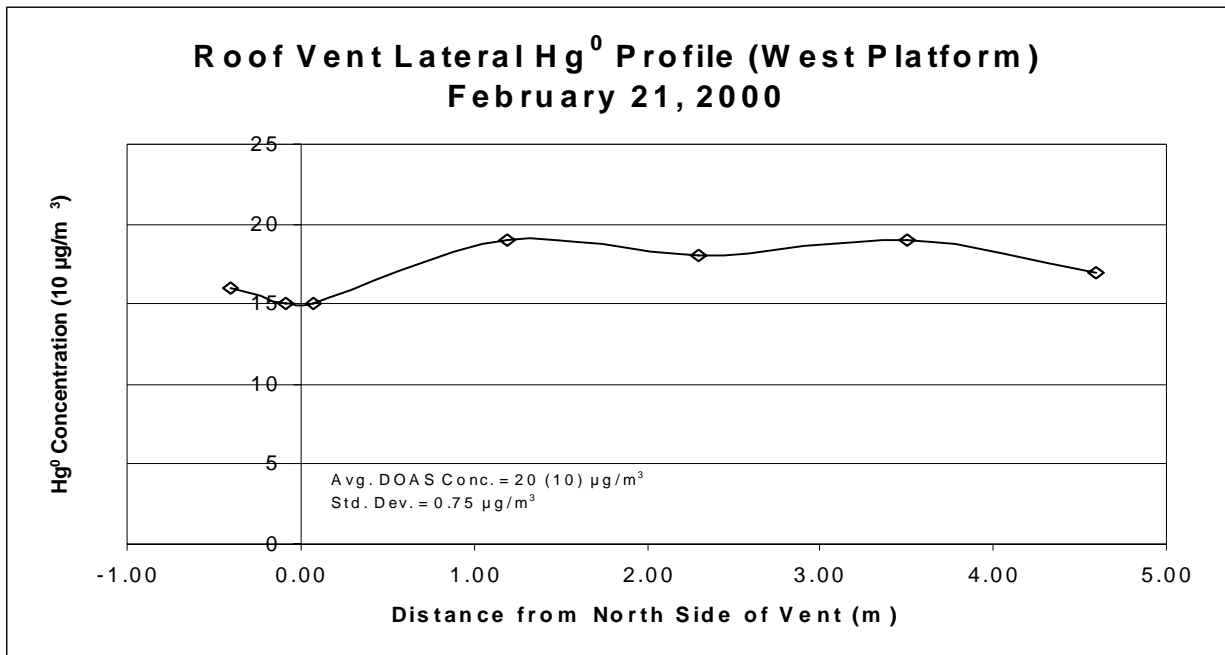

Figure 5-28. Lateral profile of elemental mercury concentration as determined by the Jerome 431-X instrument.

In the second analysis, monitoring data obtained by the UV-DOAS were compared to point measurements made using a Tekran Model 2537A automated Hg analyzer operated by ORNL. The Model 2537A is a cold-vapor atomic fluorescence spectrometer (CVAFS) originally designed for ambient air monitoring which uses gold traps to preconcentrate the sample prior to analysis. The Tekran analyzer was located in the cell building control room with air samples collected from a high-flow sampling line which extended to a point in the ceiling of the cell building ~5 m (16 ft) below the approximate center of the roof vent entrance.

Selected data from both instruments were imported into an Excel[®] spreadsheet. The two data sets were time-synchronized and plotted against each other, and a simple linear regression calculation performed on the data. The results of this analysis are shown in Figure 5-29.

As Figure 5-29 shows, the data exhibit a relatively high degree of scatter with only about 63% of the variance being explained by the linear regression. Possible reasons for these results include differences in analysis method, non-representative sampling (e.g., sample extraction at a single point vs. a path-averaged method), and sampling line losses. The data do, however, show comparable trends in Hg⁰

concentration with time (Figure 5-30) which may be useful for identifying process upsets or maintenance events as discussed below.

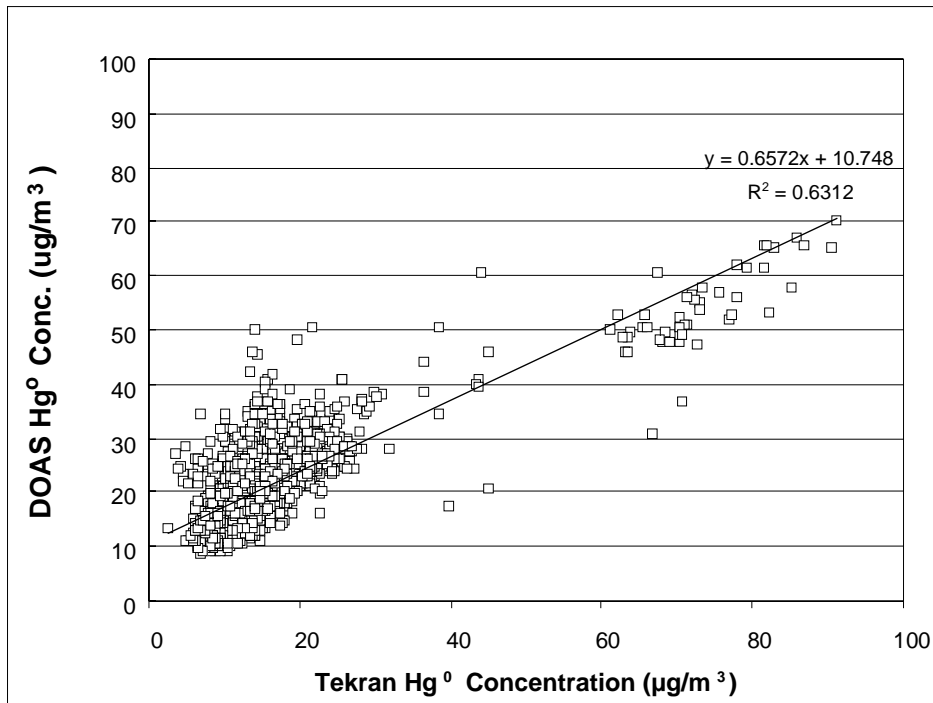

Figure 5-29. UV-DOAS/Tekran comparison (February 17-21, 2000).

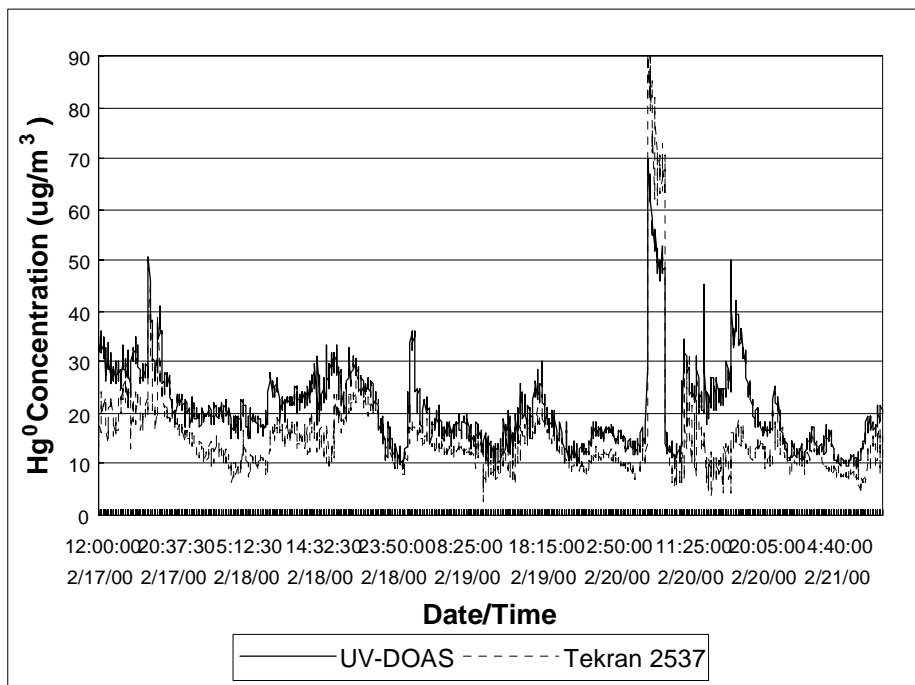

Figure 5-30. Chronology of elemental mercury concentration measured by OPSIS™ Model AR 500 UV-DOAS and Tekran Model 2537A CVAFS for February 17-21, 2000.

5.2 Tracer Gas Results

The results of the tracer gas measurements are provided in the following paragraphs. These results include both the roof vent monitoring conducted using the open-path FTIR and the manual bag sampling conducted in various building openings.

5.2.1 Roof Vent Monitoring

As was discussed in Section 4.2.1 above, the FTIR results were found to be unuseable for the purpose of determining volumetric air flow due to optical saturation of the detector. However, the qualitative results are of at least some general interest.

In the analysis of the IR spectra, several trace gases other than SF₆ were found in measurable amounts. These gases include carbon monoxide (CO), nitrous oxide (N₂O), and methane (CH₄), all of which were estimated to be in concentrations above background. (Note that background readings were obtained from the ambient FTIR located at the east plant road which was also operated by EPA as part of the larger study.) Although the emission rate of these compounds could not be quantified, it is interesting to note that three “greenhouse” gases were found in measurable quantities in the roof vent effluent. The exact source(s) of these gases could not be determined, however, from the available data.

5.2.2 Tracer Gas Study – Manual Bag Sampling

The bags were sampled manually by drawing sample air into a Tedlar[®] bag over a nominal 24-hour period. Multiple sampling locations were chosen (Figure 5-31) to obtain a distribution of tracer concentrations at key building openings. This sampling process was conducted to obtain ambient levels of SF₆ released along the open areas in the basement and in the cell room. If SF₆ were detected, it would have indicated possible release of Hg along the vents from the cell building.

The sampling results for the manual bag analyses are presented in Table 5-4. The average concentration of SF₆ for the low release days, February 17 through February 20, 2000, was 0.019 ppmv, which is just over the detection limit of 0.008 ppmv. The average concentration for the high release

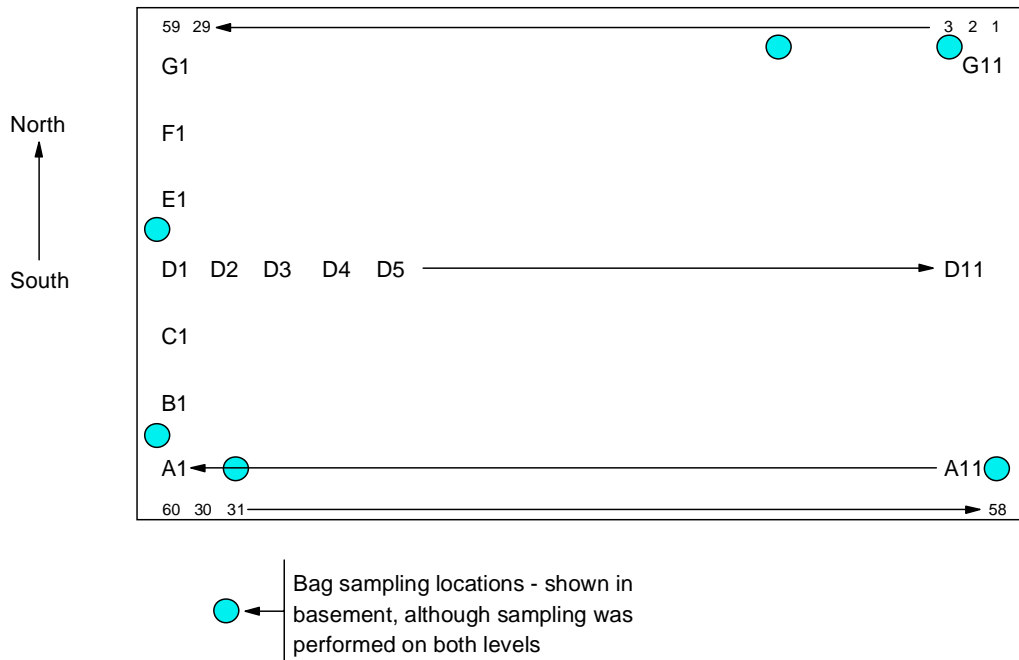

Figure 5-31. Bag sampling locations in cell building.

Table 5-4. Manual Bag Analysis Results

Bag ID	Site Description			Date Taken	Date Analyzed	Reported Concentrations (ppmv)
	Description	Column Location	Basement or Cell Room			
E8-22	Under Cell 8	G3	Basement	02/18/00	02/22/00	ND ^a
E13-22	Under Cell 13	G8	Basement	02/18/00	02/22/00	ND
A31-22	Under Cell 31	A3	Basement	02/18/00	02/22/00	0.016
A53-22	Under Cell 58	A8	Basement	02/18/00	02/22/00	0.014
B1-22	Southwest	B1	Basement	02/18/00	02/22/00	ND

Table 5-4. (Continued)

Bag ID	Site Description			Date Taken	Date Analyzed	Reported Concentrations (ppmv)
	Description	Column Location	Basement or Cell Room			
	Wall					(Continued)
DE1-22	Between D1&E1	D1 & E1	Basement	02/18/00	02/22/00	ND
UPG3-22	Cell 3	G3	Cell Room	02/19/00	02/22/00	ND
UPG13-22	Cell 13	G8	Cell Room	02/19/00	02/22/00	ND
UPA31-22	Cell 31	A3	Cell Room	02/19/00	02/22/00	0.016
UPA53-22	Cell 53	A8	Cell Room	02/19/00	02/22/00	0.017
UAB1-22	Southwest Wall	Opening B1	Cell Room	02/19/00	na	Bag leaked
UPDE1-22	Between D1&E1	Column D1 & E1	Cell Room	02/19/00	02/22/00	ND
UPB1-22	Southwest Wall	B1	Cell Room	02/20/00	02/22/00	ND
NWEND-22	Northwest Wall	F3	Basement	02/20/00	02/22/00	0.022
20UG3-22	Cell 20	G3	Cell Room	02/20/00	02/22/00	0.022
LOG13-22	Under Cell 13	G8	Basement	02/20/00	02/22/00	ND
LOA31B-22	Under Cell 31	A31	Basement	02/20/00	02/22/00	0.024
UA53-22	Cell 53	A8	Cell Room	02/20/00	02/22/00	0.020
A31-24	Cell 31	A3	Basement	02/23/00	02/24/00	ND
A53-24	Cell 53	A8	Basement	02/23/00	02/24/00	ND
G13-24	Cell 13	G8	Basement	02/23/00	02/24/00	ND
G3-24	Cell 8	G11	Basement	02/23/00	02/24/00	ND
UPDEL-25	Mid Wall	Column D1 & E1	Basement	02/24/00	02/25/00	ND
1B1-25	Southwest Wall	Opening B1	Cell Room	02/24/00	02/25/00	ND
UPG3-25	Cell 3	G3	Basement	02/24/00	02/25/00	ND
LOG13-25	Cell 13	G8	Cell Room	02/24/00	02/25/00	ND
UPA31-25	Cell 31	A3	Basement	02/24/00	02/25/00	ND
LOA53-25	Cell 53	A8	Cell Room	02/24/00	02/25/00	ND

^aDetection limit = 0.013 ppmv

days, February 22 through 23, 2000, was below the method detection limit (MDL). Although the concentrations of SF₆ on February 20, 2000, were less than 5 x MDL (MDL = 0.008 ppbV), the concentrations detected were significantly higher, on average (0.022 ppbV), than any other sampling day, suggesting very minimal Hg transport during this sampling period. The bags that detected SF₆ were located on the upper and lower northwest and southwest levels of the cell building. Samples were also taken from the standard check cylinder used to QC the long-path FTIR. The results of these measurements are presented in the Quality Control/Quality Assurance Section of this report.

5.3 Air Flow Study Results

The results of the manual velocity measurements and the associated air flow balance calculations performed for the cell building are described below.

5.3.1 Roof Vent Monitoring

The data obtained from the manual velocity measurements are shown in Figures 5-32 and 5-33 for the east and west sampling platforms, respectively. As these graphs show, the velocity profiles obtained on each platform exhibit a distinct decrease at the approximate center of the vent created by a structural member running the length of the building. In addition, the air velocity drops off rapidly outside the physical boundaries of the vent throat as would be expected.

The average air velocity measured manually by the propeller anemometer was also compared to that obtained by the optical anemometer for the same time period. The results of this comparison are provided in Table 5-5. As shown, the average air velocities determined by the two methods were within $\pm 10\%$ which is quite acceptable considering the differences in measurement technique (i.e., optical vs. mechanical), the limited amount of manual data collected, etc. Based on these results, the measurement path of the optical anemometer was considered to be located at a point representative of the average velocity and thus appropriate for use in the emission rate calculations.

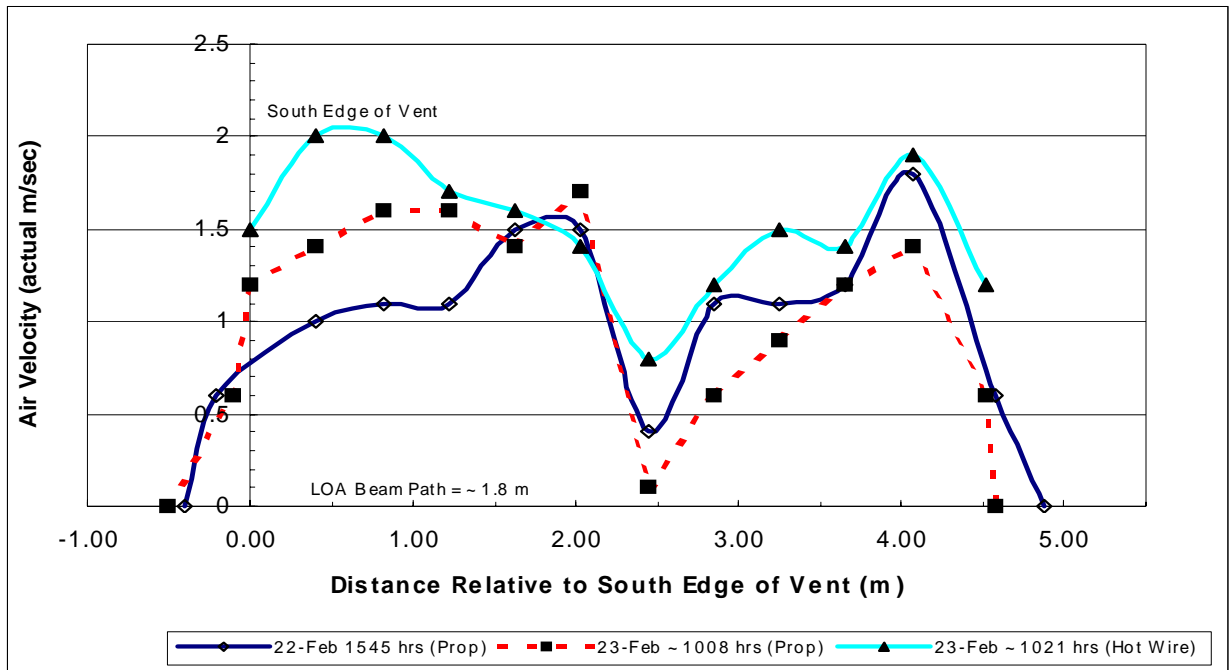

Figure 5-32. Hand-held anemometer readings at the optical anemometer measurement height on the east sampling platform, looking west.

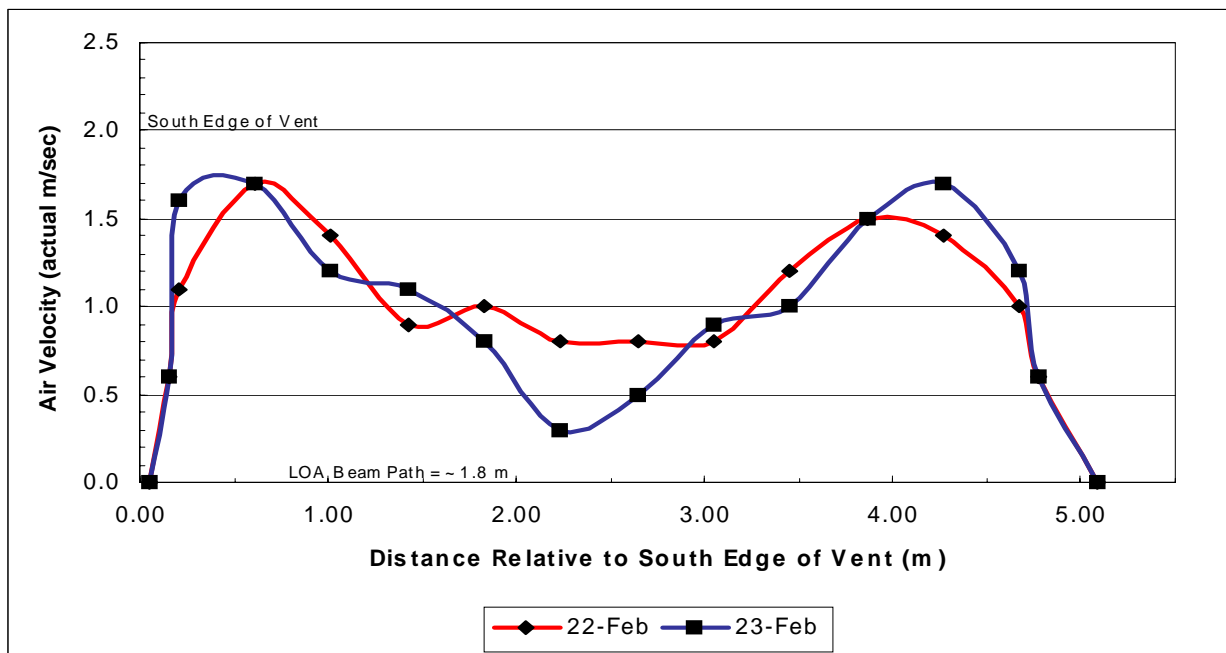

Figure 5-33. Hand-held anemometer readings at the optical anemometer measurement height on the west sampling platform, looking west.

Table 5-5. Comparison of Velocity Measurements in Roof Vent^a

Sampling Location	Sampling Date	Average Velocity (Propeller Anemometer)	Average Velocity (Optical Anemometer)	Percent Difference
East platform	February 22, 2000	0.9 m/s	0.8 m/s	10
	February 23, 2000	1 m/s	0.9 m/s	4
West platform	February 22, 2000	0.9 m/s	0.9 m/s	7
	February 23, 2000	0.9 m/s	0.9 m/s	-1

^a Rounded to one significant figure. Propeller anemometer = Davis Instruments TurboMeter[®]; optical anemometer = Scientific Technology Model LOA-104A.

5.3.2 Flow Balance Calculations

The results of the cell building flow balance calculations are shown in Table 5-6 for the three methods described in Section 4.2.4. As Table 5-6 shows, unusually good closure (i.e., 79 to 100%) was obtained in each of the three flow balance calculations performed. In addition, the three methods also correlate well with each other, providing additional confidence in the calculations performed. Finally, the high degree of closure of these flow balances lends further credibility to the air velocity measurements made by the optical anemometer in the roof ventilator to adequately characterize the air flow from the cell building.

Table 5-6. Results of Air Flow Balance Calculations for the Olin Cell Building^a

Date	Volume Balance (% Closure)	Mass Balance (% Closure)	OxyChem DMB Results ^b (% Closure)	Mass Balance (% Difference)
February 24, 2000	82	82	79	2.9
February 25, 2000	100	99	100	-0.9

^a Rounded to two significant figures.

^b Occidental Chemical Corporation direct mass balance (DMB) method as provided by Michael Shaffer.

5.4 Discussion of Results

The following sections discuss the results presented above for the roof vent monitoring, cell building air flow evaluation, and the tracer gas study conducted at the Olin chlor-alkali facility.

5.4.1 Roof Vent Monitoring

No specific pattern could be discerned from the daily plots of Hg^0 emission rate determined from the roof vent monitoring conducted in this study. Figures 5-19 to 5-27 demonstrate that various episodic events were observed where the emission rate rises for a period of time then drops back to some nominal level.

An attempt was made to correlate these episodes to either process operation (Figure 3-3) or maintenance events using plant records. Except for one specific event on February 20, when a significant Hg leak occurred in the Reductone[®] area of the building, this analysis failed to find any useful association. The plant operational logs were simply not adequate to pinpoint when certain maintenance operations were performed on the cells and thus when high airborne Hg levels might be expected. The data do suggest, however, that roof vent instrumentation may be a useful tool for long-term process monitoring to identify when problems occur in the operation of the cells which may require corrective action.

Another observation made during the study involves the impact of the high electromagnetic field on instrument operation. If future studies of this type are conducted, optical modems and cables should be used for the optical anemometer to allow logging of the data at a remote location. This procedure would substantially reduce the amount of lost data and make troubleshooting much easier for the operator.

Finally, although the concentration of Hg^0 was found to be relatively homogeneous across the lateral dimension of the roof vent, such was found not to be the case along the longitudinal dimension. This observation is illustrated in Figure 5-34 which shows Hg^0 concentration data collected during the January presurvey (Appendix G). These data were obtained by sampling from the mobile crane over the south cell line using a Jerome Model 431-X survey instrument and a long sampling tube attached to a non-conducting pole which extended to a point near the entrance of the roof ventilator throat.

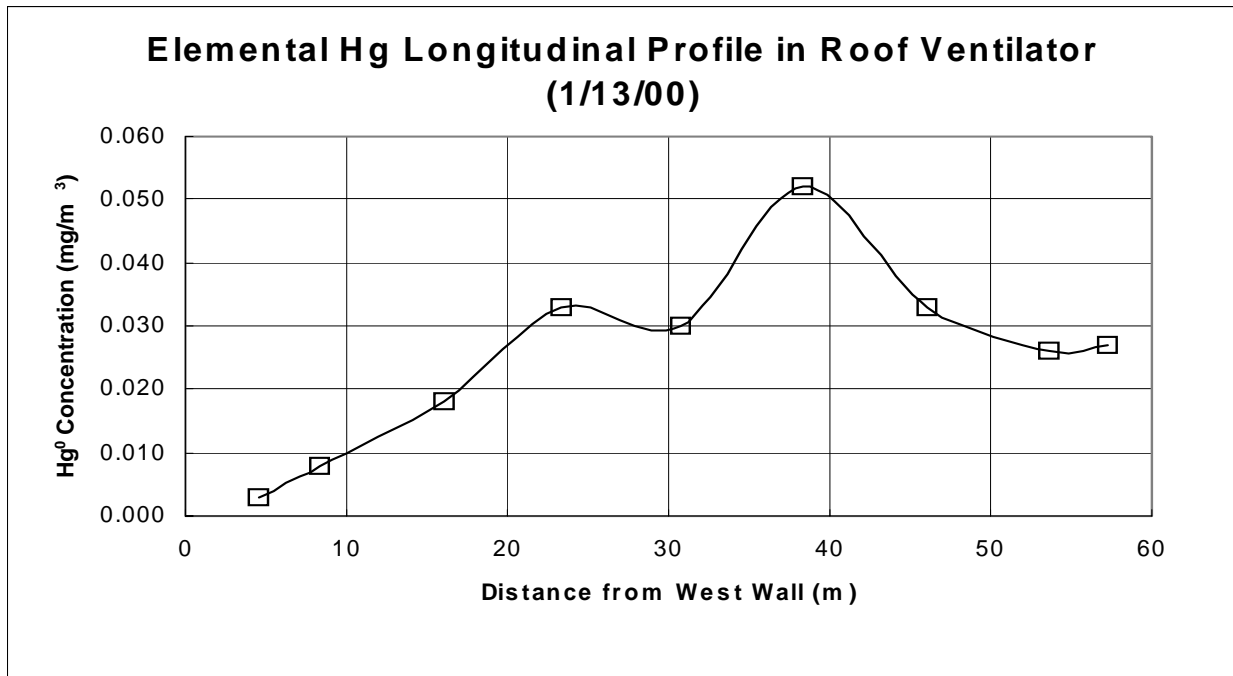

Figure 5-34. Profile of elemental mercury concentration along length of roof vent entrance as obtained during the January 2000, presurvey.

As shown in Figure 5-34, the Hg⁰ concentrations were not consistent along the length of the ventilator. The lowest concentrations were found on the west end of the building near the two large open doors. Figure 5-34 also at least partially explains the lack of correlation between the Tekran and DOAS measurements described earlier. These differences constitute yet another argument supporting spatially integrated readings in lieu of point sampling with a manifold system. However, also note that these measurements were conducted below the ventilator throat, which can also affect the homogeneity of the Hg⁰ levels obtained.

5.4.2 Building Air Flow Evaluation

Unexpectedly good closure was obtained for each of the three air flow balance calculations performed in the study, especially for February 25 (Table 5-6). One possible reason the balance obtained for February 25 has the highest degree of closure is that the manual velocity data were collected very quickly (i.e., within about 15 min) as compared to the previous day when the measurements required about

1.5 hr to complete. Conditions within the cell building tend to change rapidly; thus, there is a need to obtain the necessary data over as short a time period as possible. A much larger data base is required, however, to verify the results of the current flow study at other naturally ventilated buildings of this type.

As a final note, it was unfortunate that the roof vent tracer gas data were not useable in our analysis. The use of a tracer is a very well accepted technique for determining flow rates in situations where other methods prove difficult to implement. Therefore, the possibility of a tracer gas analysis for future flow measurement studies should not be abandoned. However, greater care is needed to verify proper instrument setup and operation in the field.

5.4.3 Comparison with Historical Information

Additional analyses can be made of the data obtained in the study which are worthy of note. First is the comparison of the current results with those of prior emission testing of chlor-alkali plants. For this analysis, only four documents were found in the literature which provide emission data for cell building roof vents. Two of these documents were EPA reports of contractor testing conducted in the 1970s as part of the original development of the Hg National Emission Standard for Hazardous Air Pollutants (R. F. Weston, 1971; Marks and Davidson, 1972). The other two documents were journal articles of two remote sensing studies conducted in Sweden and Italy (Edner et al., 1989; Ferrara et al., 1992, respectively). The remote sensing studies were conducted using light detection and ranging (LIDAR) systems to profile the plume from the cell building and as such were indirect measures of the Hg⁰ emissions from the building.

Table 5-7 summarizes the data contained in the above documents as compared to current study results. As shown, the daily emission rate obtained at the Olin facility is a factor of ~ 2 to 3 lower than that obtained in prior testing reported in the literature. It should be noted, however, that the literature values are based on generally outdated information from studies of more limited duration as compared to the current research.

Another observation that can be made from the historical data is a comparison of the estimated annual emissions from the cell building roof vent to the amount of makeup Hg added by the plant.

Table 5-7. Comparison of Current Study with Prior Research

Reference	Description of Study	Daily Hg⁰ Emission Rate (g/day)^a
Roy F. Weston, Inc. 1971	Monitoring of two roof vents and nine powered ventilators using a Barringer Airborne Spectrometer and hot-wire anemometer; one test per location	990
Marks and Davidson, 1972	Monitoring of two roof vents and ten powered ventilators using an iodine monochloride impinger train and vane anemometer; two runs per location	1,500
Edner et al., 1989	Differential absorption light detection and ranging (DIAL) of a Swedish plant; 1-week study (number of tests not specified)	720
Ferrara et al., 1992	Differential absorption light detection and ranging (DIAL) of an Italian plant; 3-day study	930 ^b
Current study	Continuous monitoring with UV-DOAS and optical anemometer in roof vent for 9-day study period	470

^a Extrapolates short-term values to annual basis assuming 24 hr/day and 365 days/yr operation. Rounded to two significant figures.

^b Average of all tests conducted. Value could be adjusted upward by at least 20% to account for interferences in the measurement path plus elimination of minor sources from the calculated average.

Assuming that the 9-day study period is indicative of the annual operation of the plant, which may or may not actually be the case, 172 kg/year of Hg⁰ would theoretically be released to the atmosphere from the cell building vent. This value represents 2.3% of the total makeup Hg⁰ added by the plant in 1997. Note, however, that Olin has implemented an aggressive Hg conservation program since 1997, and it is currently not known how much Hg was actually added during the year in which the study was conducted (2000). Therefore, the above comparison is probably not valid for the 2000 operating year. However, taking these factors into consideration, it still appears that a substantial percentage of the potential Hg emissions were not measured in the roof vent during the current study. Data from other parts of the measurement program described in Section 1.2 may, however, provide additional information on other Hg sources within the plant which are not currently available for analysis.

Finally, in the 1997 Mercury Study Report to Congress, 18.8 Mg/yr was estimated for all non-combustion Hg sources for the period 1994-95 (Keating et al., 1997). Again assuming that the above annual emissions from the current study are valid, the Olin cell building represents less than 1% of the total non-combustion Hg emissions inventory for 1994-95. Also, assuming a worst case makeup Hg consumption for the entire industry of 146 Mg as mentioned in Section 1, the Olin cell building annual emissions would constitute approximately 0.1% of this value.

Based on the above analyses, there is an apparent discrepancy between the results obtained in the current study and the potential Hg emissions from this and other CAPs. However, a number of factors could explain differences in the Hg⁰ emission rate, including better process control and increased plant maintenance. It is recommended, therefore, that extended monitoring at the Olin plant and/or monitoring at additional plants be performed to address, among other issues, maintenance events and operational transients which are suspected as being the major cause of Hg release to the atmosphere from the cell building.

SECTION 6

QUALITY ASSURANCE/QUALITY CONTROL

A number of quality control (QC) checks were made for the measurements conducted in the study. For the automated methods, both long-path and point monitors, checks included calibration using standards, daily system checks, and calibration of flow meters. For the manual techniques, QC checks included duplicate samples, field and instrument blanks, QC samples, and spiked samples. Table 6-1 summarizes the QC checks used for the various measurements conducted in the program. More detailed information on these checks can be found in the following sections. As discussed in Section 1, only the cell room data are discussed in this report. The other collaborators in this study will provide the quality assurance from their programs in separate publications.

6.1 UV-DOAS Measurements

The UV-DOAS instrument used in the roof vent was initially calibrated in the laboratory using an optical bench. In the field, instruments were calibrated using a sealed optical cell with the concentration determined based on temperature. Temperature was measured by a calibrated, laboratory-grade electronic thermometer. Calibrations are presented in Appendix H for the Hg⁰ response obtained on February 17, 24, and 25, 2000. QC checks are reported in Table 6-2, and percent completeness was shown previously in Table 5-1.

6.2 Optical Anemometry

As mentioned in the Quality Assurance Project Plan (Kinsey, et al., 2000), an assessment of precision and accuracy for the optical anemometer was not possible. However, percent completeness was calculated for each 24-hr monitoring period as shown previously in Table 5-2. In addition, QC checks were also performed each morning using the electronic calibrator supplied with the instrument.

Table 6-1. QC Checks for Experimental Methods Included in QA Plan^a

QC Check	Long-Path FTIR	UV-DOAS	SF ₆ Bag Samples
Calibration procedure	SOP in QAPjP	OP SIS™ QA in QAPjP	SOP in QAPjP
Calibration frequency	Before and after testing	Before and after testing	Before and after testing
Type of calibration standard used	Optical cell w/certified gas standard (vent only)	Sealed optical cell	Optical cell with gas standard
Standard concentration or value	25 ppm SF ₆ ; 500 ppm n-butane (vent only)	Saturated Hg vapor (function of temp.)	0.1 and 0.5 ppm SF ₆
Source of standard	Scott Specialty Gases (vent only)	OP SIS™	Spectra Gases
Standard traceability	NIST (vent only)	N/A	Certified at ±10%
Instrument flow rate	N/A	N/A	N/A
Duplicate samples	N/A	N/A	10%
Field blanks	N/A	N/A	One per bag
Instrument blanks	Nitrogen purge	N/A	Zero gas – one per day
QC samples or checks	Daily system check per SOP	Daily system check per QA manual	Daily system check per SOP
Reagent blanks (if applicable)	N/A	N/A	N/A
Spiked samples	N/A	N/A	N/A

^a SOP = Standard Operating Procedure; QAPjP = Quality Assurance Project Plan.

Table 6-2. Quality Control Checks for UV-DOAS

Description	Date Taken	Concentration (µg/m ³)	Percent Recovery (%)
Test	2/24/00	-1.2	NA
Expected 7.0 µg/m ³	2/24/00	6.45	92.1
Expected 41.7 µg/m ³	2/24/00	34.0	81.5
Expected 83.4 µg/m ³	2/24/00	72.55	87.0
Zero Test	2/24/00	-0.35	NA
Expected 5.7 µg/m ³	2/24/00	4.63	81.2
Expected 37.5µg/m ³	2/24/00	40.4	108
Expected 75µg/m ³	2/24/00	78.2	104
Zero Test	2/25/00	-0.96	NA
Expected 4.3 µg/m ³	2/25/00	4.75	110
Expected 42.5µg/m ³	2/25/00	42.0	98.8
Expected 83.3 µg/m ³	2/25/00	83.4	100

The results of these checks are summarized in Table 6-3 below. All QC checks were within the acceptable ranges specified by the manufacturer.

Table 6-3. Results of Daily QC Checks of Model 104a Optical Anemometer

Date	Output from Electronic Calibrator by Measurement Range ^a			Breakout Box Voltage	
	0.1 m/s	5 m/s	10 m/s	Channel A	Channel B
February 17	0.03	1.70	3.37	2.56	2.49
February 18	0.03	1.71	N/A	2.40	2.38
February 19	N/A	1.69	3.36	2.37	2.37
February 20	0.03	1.71	N/A	2.36	2.46
February 21	0.03	1.71	N/A	2.38	2.48
February 22	0.03	1.71	N/A	2.24	2.40
February 23	0.03	1.72	N/A	2.41	2.41
February 24	0.03	1.70	N/A	2.45	2.39
February 25	(b)	(b)	(b)	2.65	2.32

^a Readings obtained from computer DAS in m/s for each calibrator range indicated. Since a 2-in. aperture was used in place of the standard 6-in. aperture, all values shown must be multiplied by a factor of 3 to obtain equivalent value. N/A = not available.

^b DAS crashed just prior to daily QC check. Instrument operational until QC check attempted per downloaded data files.

6.3 SF₆ Release, Sampling, and Analysis (FTIR)

The SF₆ tracer gas was released as a diffuse line source along the centerline of the cell room. The tracer was provided from compressed gas cylinders through a “soaker hose” running the length of the building. Gas was metered from the cylinder using a pressure regulator and precision rotameter calibrated with SF₆ using a bubble test meter prior to deployment. Single-point calibration checks were made at least every 4 days throughout the program. Calibrations are presented in Appendix I for the rotameter calibrations obtained on February 16 and 23, 2000.

QC procedures for bag sampling and analysis were performed. Sampling QC activities were conducted separately from analytical QC. Field sampling data were recorded in a laboratory notebook. Copies of the notebook pages are presented in Appendix J.

Sampling QC included daily inspection of the FTIR spectrometer and a bag container leak check. Sampling system QC was performed prior to each sample run including blank values for each sample collection bag. Acceptable blank values were $\leq 5x$ MDL (MDL for closed cell SF₆ = 0.008 ppbV). Blank and quality control checks are reported in Tables 6-4 and 6-5, respectively.

QC procedures for the FTIR spectrometer included:

- Instrument sample cell integrity check;
- Collection of diagnostic spectra; and
- Gas standard measurements.

These procedures were conducted each test day prior to analysis. Diagnostic spectra were collected for the SF₆ gas standards which included 0.1 and 0.5 ppm SF₆. The analytical procedures for both diagnostic spectra and gas standards were identical. All calibration procedures for bag sample collection and FTIR analysis were included in the Standard Operating Procedure (SOP) as listed in Table 6-1 above.

6.4 Long-Path FTIR QA/QC Checks (Roof Vent)

Based on the quality review provided by ManTech Environmental, the data from the long-path roof vent FTIR were not used. Appendix B contains a complete description of problems with data validation.

For calibration and QA/QC purposes, the roof vent FTIR optical cell was first purged with 99% purity nitrogen. During this procedure a background spectrum was collected and recorded. After purging, the instrument's optical cell was challenged with *n*-butane certified at 500 ppm. Resulting spectra were collected and recorded. Then the cell was again purged with 99% purity nitrogen to remove any residue. The cell was then challenged with SF₆ certified at 25 ppm. Resulting spectra were collected and recorded. Finally, the cell was again purged with 99% purity nitrogen. This procedure was performed before the

FTIR began to collect data and when data collection for the study was completed. For QA/QC purposes, the FTIR was purged with 99% purity nitrogen and challenged with SF₆ throughout the sampling period.

Table 6-4. Manual Bag Sampling/Analysis Blank Control Checks^a

Bag ID	Description	Date Taken	Date Analyzed	Average Concentration (ppmv)
zero1-17	Blank	02/17/00	02/17/00	0.0000
zero2-17	Blank	02/17/00	02/17/00	0.0000
zero3-17	Blank	02/17/00	02/17/00	0.1310
zero1-18	Blank	02/18/00	02/18/00	0.0000
zero2-18	Blank	02/18/00	02/18/00	0.0017
zero3-18	Blank	02/18/00	02/18/00	0.0020
zero1-22	Blank	02/22/00	02/22/00	0.0000
zero2-22	Blank	02/22/00	02/22/00	0.0140
zero3-22	Blank	02/22/00	02/22/00	0.0140
ZERO4-22	Blank	02/22/00	02/22/00	0.0135
ZERO1-23	Blank	02/23/00	02/23/00	0.0000
ZERO2-23	Blank	02/23/00	02/23/00	0.1022
ZERO1-24	Blank	02/24/00	02/24/00	0.0000
ZERO2-24	Blank	02/24/00	02/24/00	0.0000
ZERO3-24	Blank	02/24/00	02/24/00	0.0000
ZER04-24	Blank	02/24/00	02/24/00	0.0000
ZERO5-24	Blank	02/24/00	02/24/00	0.0000
ZERO6-24	Blank	02/24/00	02/24/00	0.0000
ZERO1-25	Blank	02/25/00	02/25/00	0.0000
ZERO2-25	Blank	02/25/00	02/25/00	0.0000
ZERO3-25	Blank	02/25/00	02/25/00	0.0000

^a All high blanks were followed by recalibrations and re-analysis

Table 6-5. Manual Bag Sampling/Analysis Quality Control Checks

Bag ID	Description	Date Taken	Date Analyzed	Concentration (ppmv)	True Value (ppmv)	Percent Recovery	Comments
std 1-18	Standard	2/18/00	2/18/00	0.104	0.1	104.4	
std 2-18	Standard	2/18/00	2/18/00	0.480	0.5	96.02	
std 2a-18	Standard	2/18/00	2/18/00	0.478	0.5	95.62	
std 2-22	Standard	2/22/00	2/22/00	0.510	0.5	101.92	
std 3-22	Standard	2/22/00	2/22/00	0.115	0.1	115.1	QC check repeated (std 7-22)
std 4-22	Standard	2/22/00	2/22/00	0.122	0.1	121.6	
std 5-22	Standard	2/22/00	2/22/00	0.499	0.5	99.84	
std 6-22	Standard	2/22/00	2/22/00	0.467	0.5	93.44	

(Continued)

Table 6-5 (Continued)

Bag ID	Description	Date Taken	Date Analyzed	Concentration (ppmv)	True Value (ppmv)	Percent Recovery	Comments
std 7-22	Standard	2/22/00	2/22/00	0.486	0.5	97.2	
std 1-23	Standard	2/23/00	2/23/00	0.482	0.5	96.42	
std 2-23	Standard	2/23/00	2/23/00	0.104	0.1	103.6	
std 3-23	Standard	2/23/00	2/23/00	0.104	0.1	103.5	
std 4-23	Standard	2/23/00	2/23/00	0.095	0.1	95.3	
std 6-23	Standard	2/23/00	2/23/00	0.101	0.1	101.2	
std 1-24	Standard	2/24/00	2/24/00	0.113	0.1	113.1	QC check repeated (std 2-24)
std 2-24	Standard	2/24/00	2/24/00	0.508	0.5	101.62	
std 3-24	Standard	2/24/00	2/24/00	0.504	0.5	100.7	
std 4-24	Standard	2/24/00	2/24/00	1	0.5	103.76	
std 1-25	Standard	2/25/00	2/25/00	0.502	0.5	100.36	
std 2-25	Standard	2/25/00	2/25/00	0.110	0.1	110.1	QC check repeated (std 3-25)
std 3-25	Standard	2/25/00	2/25/00	0.488	0.5	97.52	
VanQC-25	FTIR Roof QC	2/25/00	2/25/00	20.7	25	82.7496	Check against Roof FTIR's QC
std 4-25	Standard	2/25/00	2/25/00	0.490	0.5	98.02	
std 5-25	Standard	2/25/00	2/25/00	0.104	0.1	103.8	
std bag 1-25	Standard in Bag	2/25/00	2/25/00	0.083	0.1	83.3	
std bag 2-25	Standard in Bag	2/25/00	2/25/00	0.430	0.5	86.06	
std bag 3-25	Standard in Bag	2/25/00	2/25/00	0.087	0.1	87.2	
std bag 4-25	Standard in Bag	2/25/00	2/25/00	0.439	0.5	87.84	
VanQC-25	FTIR Roof QC	2/25/00	2/25/00	23.3	25	93.196	Check against Roof FTIR's QC

6.5 On-Site Audit

An on-site audit was performed by two members of EPA-APPCD's QA staff. An audit report was written and submitted to the research team for their response. The written responses from the research team were accepted as submitted without further clarification.

6.6 Data Quality Indicators

Data quality indicators (DQIs) were described in the Quality Assurance Project Plan, Section 4. The field verification of the DQI results is presented in Table 6-6. With the exception of the FTIR roof vent monitoring, only one other DQI failed to meet acceptance criteria. Because of the optical saturation of the FTIR detector used for the Roof Vent monitoring, the DQIs were not achieved; the FTIR results are discussed in Section 4.2.1.

Table 6-6. Data Quality Indicator Results

Parameter	Measurement Method	Data Quality Indicator	Value Obtained	Achieved criteria?
SF ₆ Tracer Concentration	Manual bag sampler	Precision 20%	12.2 - 16.7%	Yes
		Accuracy 6%	4.4 - 4.7%	Yes
		Detection Limit 6 ppb	6-13 ppb	----- ^a
Air Velocity in Cell Building	Long-path optical anemometer	Completeness 95%	96.4%	Yes
		Detection Limit 0.2 m/s	0.2 m/s	Yes
		Completeness 90%	93%	Yes
Total Gas-Phase Hg ⁰	Roof vent UV-DOAS	Precision 15%	----- ^b	----- ^b
		Accuracy 15%	8 - 18.8%	Yes
		Detection Limit ~130 ng/m ³	----- ^b	----- ^b
		Completeness at 75%	80 - 89%	Yes

^a The detection limits for the bag sampling determined during each analysis day of the field testing ranged from 6 to 13 ppb. The highest detection limit value determined was used to facilitate data processing and determine daily analytical values.

^b Information on achievement of Data Quality Indicators is not available from field data. The references in the Data Quality Indicator table of the Quality Assurance Project Plan were generated in the laboratory for backup of published specifications. The procedures for establishing these values for non-Criteria Pollutants were never intended to be "field verified." The actual procedure used to verify the values is written for the gaseous Criteria Pollutants (SO₂, NO₂, O₃) which are available in cylinders or from a generator. The gases are introduced into a cell in the measurement path to determine precision and accuracy. For mercury, vapor standards are not used by the testing group (Opsis); the measurement work is performed with closed cells. A closed cell was not available for the field test; therefore, field verification of the literature value for measurement of Hg⁰ could not be performed.

SECTION 7 REFERENCES

- ASHRAE. 1981. American Society of Heating, Refrigerating and Air-Conditioning Engineers (1981). *ASHRAE Handbook 1981 Fundamentals*, Atlanta, GA.
- Chlorine Institute. 1999. *Second Annual Report of the Chlorine Institute to the United States Environmental Protection Agency*, Chlorine Institute, Washington, DC.
- Cowherd, C., Jr., and J. S. Kinsey. 1986. *Identification, Assessment, and Control of Fugitive Particulate Emissions*. U.S. Environmental Protection Agency, Air and Energy Engineering Research Laboratory, Research Triangle Park, NC, August; EPA-600/8-86-023 (NTIS PB86-230083).
- Edner, H., G. W. Faris, A. Sunesson, and S. Svanberg. 1989. *Atmospheric Atomic Mercury Monitoring Using Differential Lidar Techniques*. *Applied Optics*, 28, 921-930.
- EPA. 1984. U.S. Environmental Protection Agency. *Method 14-Determination of Fluoride Emissions from Potroom Roof Monitors for Primary Aluminum Plants*, 40 Code of Federal Regulations, Part 60, Appendix A, February 21, 1984.
- EPA. 1999. U.S. Environmental Protection Agency. *Compendium Method TO-16, Long-Path Open-Path Fourier Transform Infrared Monitoring of Atmospheric Gases*, in "Compendium of Methods for the Determination of Toxic Organic Compounds in Ambient Air," Center for Environmental Research Information, Office of Research and Development, Cincinnati, OH, January; EPA/625/R-96/010b (NTIS PB99-172355).
- Ferrara, R., B. E. Maserti, H. Edner, P. Ragnarson, S. Svanberg, and E. Wallinder. 1992. *Mercury Emissions into the Atmosphere from a Chlor-Alkali Complex Measured with the Lidar Technique*. *Atmospheric Environment*, 26A, 1253-1258.
- Hunt, W. 1998. Personal communication from William Hunt, Director, Emissions Monitoring and Analysis Division, Office of Air Quality Planning and Standards, U.S. Environmental Protection Agency to Michael Palazzolo, ALCOA Corporation, Pittsburgh, PA, July 9, 1998.
- Keating, M. H., D. Beauregard, W. G. Benjey, L. Driver, W. H. Maxwell, W. D. Peters, and A. A. Pope. 1997. *Mercury Study Report to Congress, Volume II: An Inventory of Anthropogenic Mercury Emissions in the United States*, U.S. Environmental Protection

Agency, Office of Air Quality Planning and Standards, Research Triangle Park, NC, December; EPA-452/R-96-004 (NTIS PB98-124746).

Kinsey, J. S., M. Landis, D. France, S. Lindberg, J. Nriagu, J. Swift, G. Ramsey, J. Pau, F. Anscombe, and N. Adams. 2000. *Characterization of Mercury Emissions at a Chlor-Alkali Plant*, Quality Assurance Project Plan. U.S. Environmental Protection Agency, National Risk Management Research Laboratory, Research Triangle Park, NC, February 11, 2000.

Landis, M. S., R. K. Stevens, T. Crawford, D. France, C. Secrest, and S. Lindberg. 2000. Speciation of Mercury Emissions from a Chlor-Alkali Plant, Presented at the AWMA International Symposium on the Measurement of Toxic and Related Air Pollutants, Research Triangle Park, NC, September 12-14, 2000.

Marks, P. J., and J. Davidson. 1972. *EPA Test No. 72-PC-04, B. F. Goodrich Chemical Company Chlor-Alkali Plant Calvert City, Kentucky*; EPA Contract No. CPA-70-132, Task Order No. 3, U. S. Environmental Protection Agency, Office of Air Quality Planning and Standards, Research Triangle Park, NC, May.

Rosario, I. 2001. Personal communication from Iliam Rosario, Office of Air Quality Planning and Standards, U.S. Environmental Protection Agency, Research Triangle Park, NC, August 15, 2001.

Weston, Roy F. 1971. *Georgia-Pacific Chlor-Alkali Plant, Bellingham, Washington*; EPA Contract No. CPA-70-132, Task Order No. 2, U. S. Environmental Protection Agency, Office of Air Quality Planning and Standards, Research Triangle Park, NC.

Appendix A

Description of Buildings and Processes at the Olin Facility

(Intentionally Blank)

Olin CORPORATION

AUGUSTA, GEORGIA

November 4, 1995

30 YEAR CELEBRATION COMMUNITY OPEN HOUSE PLANT TOUR

TOUR ROUTE -- AT A GLANCE

1 OCEAN BUILDING

This building contains the equipment we use to respond to product emergencies that occur outside the plant. The acronym OCEAN stands for Olin Chemical Emergency Action Network. We have a trained team that will respond to a product emergency 24 hours/day, 7 days/week. If you desire, as soon as we finish our tour, you will be able to see the OCEAN trailer, which is set up in front of the plant in the parking lot. You will be able to view our emergency equipment.

2 ANODE SHOP

This shop contains the equipment used to rebuild worn or damaged anodes that have been removed from the cells. The rebuilt anodes are then placed in stock and are reinstalled in another cell at a later date.

The anode is constructed of titanium metal that is coated with a thin precious metal coating. The coating will wear off in time and will eventually have to be replaced.

3 SODIUM HYDROSULFITE AREA (*Reductone[®] and Hydrolin[®]*)

- Sodium Hydrosulfite loading and storage

Sodium Hydrosulfite is stored in six insulated fiberglass tanks. It must be kept cool since it will decompose when it gets too warm. It is stored at a slightly stronger concentration than required by our customers and is diluted to proper specifications as it is loaded into insulated trailers through the piping on the loading stations. 135,000 gallons of material can be stored in these tanks.

- Sodium Hydrosulfite Refrigeration

The Sodium Hydrosulfite reaction is exothermic -- it gives off heat. This heat must be removed from the process. The major portion of the heat removal is accomplished using the two large Carrier Corporation refrigeration units housed in this building.

- Sodium Hydrosulfite Reactors

The Sodium Hydrosulfite reactors are sophisticated mixers. They take in water, sulfur dioxide, caustic and sodium amalgam to produce a solution of sodium hydrosulfite. The operating parameters -- acidity concentrations and mixing rates -- must be carefully controlled to get the proper product quality. Computers help control this operation using software designed by Olin Technical Center Engineers.

4 FIRE HOSE STATION

The small red building located on the side of the roadway contains fire hoses and other fire fighting equipment. These stations are located throughout the plant.

5 SAFETY SHOWER

Also, located throughout the plant are many safety showers and eye wash stations. In the event an employee is exposed to acid, caustic, or other chemicals, a safety shower is always close by so the employee can quickly turn on the shower and flush away the dangerous material.

6 MAIN CONTROL ROOM

This control room has equipment used to monitor all major plant processes. The front panel houses the equipment which measures and controls the amount of DC electrical power applied to the cells. The back panel contains instrumentation to monitor and control most of the major processes in the plant, such as tank levels, pH measurements, line pressures, etc.

7 AUTOMATIC ANODE ADJUSTING SYSTEM

This computer controlled system continuously scans all sixty cells and automatically adjusts the anodes in each cell to optimize the operation of each. By doing so, the amount of electrical power needed to produce a given amount of product is greatly reduced and the life of the anodes is greatly extended since the computer can make this adjustment far more accurately than humans can.

8 CELL ROOM

The cell room is the heart of our process. Here up to 160,000 amps of DC electricity pass through the 60 electrolytic cells. In the cell, brine (salt water) is electrolytically reduced to sodium and chlorine. The wet chlorine gas from the cells flows through a drying system to remove all the water from it and then travels on to the compressor building. The sodium combines with mercury and flows to the decomposer. In the decomposer, the sodium reacts with water and forms sodium hydroxide (caustic). Caustic is pumped through cooling and filtration equipment and then is transferred to product storage. A by-product from the decomposer is hydrogen gas. It passes through coolers and then on to blowers. It is burned in our boilers for steam generation. It is also used for production of hydrochloric acid and it is sold to Sunox Corporation.

9 BRINE DECHLORINATION

In this area, the residual chlorine left in the spent brine leaving the cells is removed. This is accomplished by passing the brine through two tanks that are kept under a high vacuum. The vacuum “boils” the chlorine gas out of the brine stream. The chlorine is recovered and the dechlorinated brine is pumped to the CP Salt Tank where it picks up a renewed supply of salt prior to beginning its return trip to the cells.

10 HYDROGEN BLOWERS

Hydrogen is taken from the decomposers and passes through coolers that are cooled with chilled water. The cooling process removed most of the heat and mercury. The mercury is returned to the process. Hydrogen is then compressed using one or both blowers and sent to the boiler house where it is used as fuel and is also sent to other users.

11 AC POWER DISTRIBUTION

Georgia Power provides our electrical power. Incoming voltage is 115,000 volts. Here we step it down to 13,800 volts, rectify part of it for the cell room use and distribute the remaining for usage throughout the plant at various voltages (2400, 480, 120).

12 BRINE FILTERS

This is the first stage of brine purification. Fourteen brine filters are used to filter impurities from the brine. Each filter is independent of all others and must be removed from service periodically and backwashed for cleaning. The dirty backwashed brine is then collected in a tank, cleaned and recycled in the filter backwash system.

13 BRINE SETTLER

The 480,000 gallon brine settler tank is used to settle out insoluble sludge in the brine. The sludge is flushed out the bottom of the settler.

14 PURASIV® UNITS

Hydrogen is a by-product of the chlor/alkali process and it is contaminated with small quantities of mercury. The mercury concentration must be further reduced before the hydrogen can be used. This is accomplished by passing the hydrogen through packed carbon beds, which absorb mercury. Absorbers polish and further remove mercury before the hydrogen is sent to our HCl plants.

15 BOILER HOUSE

The steam generation plant consists of two separate boilers -- each capable of producing 15,000 pounds of steam per hour at 250 pounds per square inch of pressure. They are normally fired with hydrogen. They can operate on natural gas, if necessary.

The steam is used throughout the plant for various purposes, such as brine dechlorination, brine heating, steam tracing of lines and heating certain tanks.

16 SECONDARY TREATMENT

All liquid waste streams contaminated with mercury must be cleaned before allowing them to proceed into our waste treatment system. On the average, the concentration of mercury in these wastes is reduced to less than 50 parts per billion of the discharged solution.

17 DECOMPOSER REPAIR BUILDING

The Decomposer Repair Building holds equipment to rebuild and repack cell room decomposers. The decomposer is filled with graphite pellets which aid in creating the sodium hydroxide solution.

18 SUNOX CORPORATION

The Sunox Corporation is one of Olin's customers. They purchase hydrogen gas from Olin. It is delivered to them through the pipeline along the side of the roadway. They receive and compress the hydrogen gas and load it into the trailers parked at the loading stations. The hydrogen is then shipped to customers in Augusta and throughout the Southeast.

19 INSTRUMENT AND ELECTRICAL SHOP

This shop is equipped with test equipment and tools required to repair and troubleshoot the electrical equipment and the large number of instruments needed to keep the Augusta Plant operating efficiently.

20 COOLING TOWERS

These large cooling towers are one of the ways Olin reduces water consumption. The plant uses about 6000 gallons per minute of water to remove heat from the process by pumping the water through various heat exchangers. The hot water is then recycled back to the cooling towers where evaporation cools the water so it can be used again.

21 PLANT EFFLUENT SYSTEM

Waste water streams are collected throughout the plant in the process sewer system. This is the covered concrete ditch running through the center of the plant. Also, all rainwater runoff is collected. All of this water is monitored for pH, mercury, and chlorine content before it is released. If the streams are not acceptable, they are treated in the large tanks you see beside the road before the water is discharged to the Savannah River through a monitored and regulated national pollutant discharge elimination system.

22 GROUND WATER FILTERS

The square filters beside the roadway are used to treat the groundwater from shallow wells around the plant. Here rainwater that has collected underground is pumped to the surface, checked for pH and mercury content, treated if necessary and released.

23 CP SALT STORAGE TANK

The CP salt is received in 100 ton hopper cars from Olin's diaphragm cell plant in McIntosh, Alabama. It is pumped from the hopper cars into the CP salt storage tank, from which it is pumped to the cell building.

Spent brine returns here from the cell room after it has been stripped of its salt in the cells. The depleted brine flows into the "diplegs" where it is resaturated before it is sent to the filters on its way back to the cells.

The Brine Saturation System has been retired for several years but can be reactivated if needed. It serves the same function as the CP salt tank.

24 RAILROAD YARD

A significant portion of raw materials and finished product is handled by rail. We have six tracks in the plant designed and laid out so that shuffling of cars is possible. Each track serves its own purpose with track #3 being the outward product shipment track. Southern Railway makes one switch daily. We perform other switching using one of our two Trackmobiles.

25 CHLORINE LOADING AND STORAGE

Liquid chlorine may be loaded directly from the process into rail cars at loading stations #1 & #2 or stored in one of four chlorine storage tanks. Stored chlorine will be later loaded into railcars or shipped to customers through a pipeline.

26 INDUSTRIAL FILTER

The dirty backwash brine from the brine filters is pumped through the industrial filter where it is cleaned up and recycled. The industrial filter must be cleaned daily after brine filter backwashing is completed and the sludge has been removed.

27 HYPO TANKS AND BLEACH SYSTEM

In these tanks we create a weak caustic solution. This solution reacts with chlorine to form sodium hypochlorite (hypo). During process upsets, this system will keep us from emitting chlorine to the atmosphere. It acts as a "scrubber" to remove chlorine from the process. Chlorine gas from the process can also be added to the caustic solution to increase the amount of hypo produced. The hypo is then sold as bleach. The hypo is similar to the material you purchase at the store under the trade name Clorox[®] Bleach, but we manufacture a much stronger solution.

28 HYDROCHLORIC ACID PLANTS

The original hydrochloric acid plant was built in 1982 to supply approximately 3 tons per day of acid to treat the brine system. Starting in 1983 some of the acid was sold to customers. Various modifications and additions to the basic equipment have been made over the years so that today the original burner system produces 30 tons per day of

hydrochloric acid. In 1992, a near duplicate unit was added to the west, giving us an additional 30 tons per day capacity.

The acid is made by burning hydrogen and chlorine together in a furnace. The resulting HCl vapors are then absorbed into purified water to form a 37% acid solution. The acid is then piped to the large white storage tanks, where it is stored until it is shipped to customers in either tank trucks or railcars.

29 COMPRESSION AND LIQUEFACTION

Chlorine gas is pulled from the cells by two banks of compressors located in this building and pushed through two liquefiers where the chlorine gas is condensed into a liquid. From there, it proceeds to the loading and storage area. The liquefiers condense about 99% of all the chlorine gas entering them. The remaining 1% is either absorbed into the inlet brine stream or sent to the hypo system.

The compressor building also houses the plant air compressors. They provide dry, compressed air for various uses in the plant. This system consists of two main plant air compressors, two high pressure booster compressors, one instrument air compressor and one back-up diesel powered air compressor.

30 CAUSTIC AREA

There are two main caustic storage tanks -- each capable of holding 250,000 gallons (800 tons) of caustic soda. The caustic is pumped from here into tank cars or tank trucks for shipment to our customers.

The two tall, narrow tanks are caustic day tanks and are dedicated to service for Federal Paper Board. Caustic is pumped to Federal Paper from these tanks through a 7,000 foot long pipeline.

31 MAINTENANCE SHOP AND WAREHOUSE

Most plant equipment repairs are handled in our own shop. It is equipped with tools, lathes and other machinery that enable us to accomplish this. It is made up of three departments -- mechanical, instrumentation and electrical. Very little maintenance work is done outside of the plant.

Our warehouse, situated in the center of the building, provides ready access to most materials and supplies necessary for continuous plant operations.

32 ENGINEERING

The plant has a technical staff which provides project and technical support for the plant. We have the ability to generate computer drawings (CAD) and manual drawings. Plant drawings are stored in this area.

33 QUALITY CONTROL LABORATORY

The laboratory responsible for the Quality Assurance of all of our outbound products and inbound raw materials. The Lab also ensures we are in compliance with the parameters of various plant effluents. In addition, the Lab furnishes the plant with analyses of various streams in the process in order to monitor equipment performance and minimize downtime. The Augusta Plant is an ISO 9002 registered facility.

34 DATA PROCESSING

The plant has its own computer network (LAN) and can also communicate with other Olin plants (WAN). The networks are administered from this area.

35 MEDICAL

The plant has a medical department staffed with a Certified Occupational Health Nurse. This area is equipped to handle on site emergencies as well as routine physicals, exams, etc.

REMARKS

This concludes your tour of the Augusta Plant. Please return your safety gear to the boxes provided. Please return your copy of the tour script if you don't intend to keep it for future reference. If you are interested in seeing a further demonstration of the types of equipment we have on hand to respond to an outside emergency, we encourage you to visit the OCEAN trailer that is set up in the parking lot. If it is not your wish to visit the OCEAN trailer, join the other visitors in the tent area at this time. Thank you for visiting our plant and participating in our tour.

Appendix B
FTIR Spectral Analyses Conducted
by ManTech, Inc. (Jeff Childers)

(Intentionally Blank)



December 11, 2003

To: E. Hunter Daughtrey, Jr., Area Supervisor

From: Jeffrey W. Childers, Principal Scientist

Subject: WA-IV-119 — FTIR Data Interpretation Support

1.0 Background

The Air Pollution Prevention and Control Division (APPCD) participated in a major field experiment that was conducted in February of this year to characterize the mercury emissions from a chlor-alkali plant in Augusta, GA. A tracer gas, SF₆, was released at a controlled rate on the cell building floor to determine the total volumetric air flow from the roof vent of the building. One method used to determine the concentration of SF₆ emitted from the roof vent was open-path Fourier transform infrared (OP/FTIR) spectrometry. Approximately 3000 OP/FTIR spectra were obtained over a 10-day monitoring period. A subset of these data containing 305 spectra was analyzed under this work assignment.

The primary objective of this Work Assignment was to provide technical support to the APPCD for the interpretation, analysis, and quality control (QC) of OP/FTIR spectra data collected during the field test at the chlor-alkali plant. ManTech staff applied QC procedures developed under previous Work Assignments to NERL to the spectral data collected during the Augusta field study. These procedures are described in the *FT-IR Open-Path Monitoring Guidance Document*¹ and *Compendium Method TO-16—Long-Path Open-Path Fourier Transform Infrared Monitoring of Atmospheric Gases*.² Additional

guidance and operating procedures are given in an ASTM guide³ and standard practice.⁴ The QC and data interpretation procedures applied to the OP/FTIR data collected at the chlor-alkali plant included:

- Inspection of the single-beam spectra for evidence of detector saturation or excessive stray light;
- Measurement of the signal strength over time and the relative signal intensities in different spectral regions;
- Estimation of the random baseline noise between successive data files over different spectral regions;
- Development of a synthetic background spectrum;
- Examination of the range of absorbance values exhibited by the SF₆ spectral features;
- Identification of any interfering species;
- Generation of relevant reference spectra from the HITRAN data base;
- Inspection of the absorbance files for wavenumber shifts and changes in resolution;
- Development and evaluation of an analysis method;
- Comparison of the concentration values generated by the automated multivariate data analysis method to the manual comparison method or advanced nonlinear algorithms; and
- Development of relevant control charts.

2.0 Results and Discussion

2.1 *Inspection of the Single-beam Spectra for Evidence of Detector Saturation or Excessive Stray Light*

Two steps that should be completed during the initial instrument setup before data are collected include determining the distance at which the detector becomes saturated and measuring the signal due to internal stray light. Apparently, neither of these two steps was done during this study. The ramifications of this oversight on the accuracy of the reported concentration data are discussed below.

2.1.1 *Determining the Distance to Detector Saturation*

The distance at which the detector becomes saturated determines the minimum pathlength over which quantitative data can be obtained with that particular instrument configuration. A procedure for determining this distance is given in Section 3.3 of the *FT-IR Open-Path Monitoring Guidance Document*. Evidence of detector saturation indicates that the detector is not responding linearly to changes in the incident light intensity and, therefore, will not respond linearly to changes in concentration of the gases along the path. Detector saturation causes errors in how the interferogram is sampled. These errors can result in aliasing or folding of spectral features outside the normal sampling frequency range into the recorded spectrum.⁵ This effect gives rise to abnormal shapes in the single-beam spectrum and the appearance of non-physical energy in spectral regions where there is no real spectral information. Because this anomalous information becomes part of the recorded interferogram, there is no way to compensate for the errors in the photometric accuracy due to detector saturation.

Once the OP/FTIR system is set up along the desired monitoring pathlength, a single-beam spectrum should be obtained. This spectrum should be inspected in the wave number region below the detector cutoff frequency. For most MCT detectors commonly

used in OP/FTIR applications, this cutoff frequency occurs between 650 and 700 cm^{-1} . The instrument response in this wavenumber region should be flat and at the baseline. An elevated baseline in this region is due to non-physical energy and indicates that the detector is saturated. If an elevated baseline is observed in this region of the single-beam spectrum, the operator has three choices:

- Increase the monitoring pathlength until the instrument response is flat and at the baseline in this region;
- Place a wire mesh screen in the modulated, collimated IR beam to attenuate the signal intensity; or
- Rotate the retroreflector to reduce the signal intensity.

A representative single-beam spectrum from the Augusta field study is shown in Figure 1. This spectrum exhibits evidence of nonphysical energy in spectral regions that should be flat and at the baseline, including those below the detector cutoff frequency and in the totally opaque spectral regions between 1400 and 1800 cm^{-1} and 3600 and 3900 cm^{-1} . This spectrum also exhibits an unusual curvature in the baseline in the 2550 to 2850- cm^{-1} region. As a comparison, a single-beam spectrum collected in Research Triangle Park (RTP), NC, with an ETG OP/FTIR system over a 414-m total path is shown in Figure 2. The spectrum collected in RTP over a longer pathlength exhibits a flat baseline below the detector cutoff frequency and a steadily decreasing baseline from 2400 to 3250 cm^{-1} .

All of the 305 spectra examined in the subset of data collected during the Augusta study exhibit evidence of detector saturation. Because of this observation, the accuracy of the concentration values reported from this data set is suspect and there is no way to assess errors in these measurements. In addition to errors in the absolute concentration measurements, changes in relative concentrations from one spectrum to another are most likely nonlinear and cannot be quoted with any certainty.

2.1.2 Measuring the Signal Due to Internal Stray Light

Single-beam spectra recorded with an OP/FTIR monitor can exhibit a non-zero response in wavenumber regions in which the atmosphere is totally opaque. If the detector has been determined to be responding linearly to changes in the incident IR intensity, this non-zero response can be attributed to internal stray light in monostatic instruments that use a single telescope to transmit and receive the IR beam. The presence of internal stray light causes errors in the photometric accuracy, and ultimately, errors in the reported concentration values. The effects of stray light on photometric accuracy are illustrated in Section 3.5 of the *FT-IR Open-Path Monitoring Guidance Document*. If uncorrected, the presence of stray light results in errors in the concentration measurements approximately equal to the percentage that the stray light contributes to the total signal.

Evidence of internal stray light is observed in the single-beam spectrum collected at RTP in the CO₂ absorption region between 2300 and 2380 cm⁻¹ (see Figure 2). The strong CO₂ absorption bands in this region should extend completely to the baseline. However, in this case, the presence of internal stray light causes the apparent baseline to be elevated. In this particular instrument, stray light contributed to approximately 6% of the total signal. No evidence of stray light can be observed in the single-beam spectra collected during the Augusta study (see Figure 1). However, the severe nonlinearity exhibited by these spectra prevents observation of the presence of stray light. A single-beam spectrum of the internal stray light was not supplied with this data set. Therefore, the effect of stray light on the data collected during the Augusta study cannot be determined. If stray light does contribute to the total signal in these spectra, the reported concentration values would contain errors proportional to the amount of stray light.

2.2 *Measurement of the Signal Strength over Time and the Relative Signal Intensities at Different Spectral Regions*

The magnitude of the signal strength is indicative of the performance of the instrument, i.e., the output of the source or response of the detector, and the alignment of the transmitting/receiving telescope and the retroreflector. The relative signal strength over different spectral regions is also indicative of the instrument performance and is influenced, among other factors, by the internal alignment of the interferometer. For example, if the interferometer is misaligned, the signal strength in the high wavenumber region will be relatively low.

The signal strengths at 985, 2500, and 4400 cm^{-1} were measured in the subset of 305 single-beam spectra collected during the Augusta study. The signal strength at 985 cm^{-1} is reported directly, whereas the signal strengths at 2500 and 4400 cm^{-1} are ratioed to that at 985 cm^{-1} to determine the relative signal strength in the single-beam spectra. Plots of the signal strength at 985 cm^{-1} and the relative signal strengths at 2500 and 4400 cm^{-1} for the single-beam spectra in this subset are given in Figures 3 – 5.

The signal strength at 985 cm^{-1} over time is shown in Figure 3. This signal strength in arbitrary units ranged from 67.22 to 69.96 with a mean and standard deviation of 68.41 ± 0.59 , for a relative standard deviation of 0.86%. The signal strength at 2500 cm^{-1} relative to that at 985 cm^{-1} ranged from a ratio of 0.832 to 0.854, with a mean and standard deviation of 0.842 ± 0.005 and a relative standard deviation of 0.59% (see Figure 4). The signal strength at 4400 cm^{-1} relative to that at 985 cm^{-1} ranged from a ratio of 0.193 to 0.210, with a mean and standard deviation of 0.201 ± 0.004 and a relative standard deviation of 2.0 % (see Figure 5).

The overall signal strength as measured in the single-beam spectra at 985 cm^{-1} and the relative signal strengths measured at 2500 and 4400 cm^{-1} were nearly constant throughout the monitoring period represented by the 305 spectra analyzed in this subset of spectra from the Augusta study. These results indicate that no significant changes in the instrument performance or alignment occurred during this time period.

2.3 *Estimation of the Random Baseline Noise Between Successive Data Files over Different Spectral Regions*

Another indicator of instrument performance is the random baseline noise. This noise is measured as the root-mean-square (RMS) deviation between successive single-beam spectra collected sequentially during a monitoring period. To make this measurement, a series of absorption spectra was created from the subset of single-beam spectra by using the preceding single-beam spectrum as the background spectrum. For example, spectrum #d0224302 was used as the background spectrum for single-beam spectrum #d0224303, and so on. The RMS deviation was measured between 958 and 1008 cm^{-1} , 2480 and 2530 cm^{-1} , and 4375 and 4425 cm^{-1} and is reported in absorbance units. The random baseline noise measurements from the subset of single-beam field spectra over time are given in Figures 6 – 8.

The random baseline noise between 958 and 1008 cm^{-1} ranged from 0.111×10^{-3} to 0.405×10^{-3} absorbance units, with a mean and standard deviation of $0.217 \times 10^{-3} \pm 0.053 \times 10^{-3}$ (see Figure 6). The random baseline noise between 2480 and 2530 cm^{-1} ranged from 0.037×10^{-3} to 0.073×10^{-3} absorbance units, with a mean and standard deviation of $0.056 \times 10^{-3} \pm 0.006 \times 10^{-3}$ (see Figure 7). The random baseline noise between 4375 and 4425 cm^{-1} ranged from 0.179×10^{-3} to 0.368×10^{-3} absorbance units, with a mean and standard deviation of $0.255 \times 10^{-3} \pm 0.029 \times 10^{-3}$ (see Figure 8).

Although there was some variability in the random baseline noise measurements (the relative standard deviations for these measurements ranged from 11 to 24%) there were no obvious outliers in these data. The RMS noise levels in each spectral region were within the ranges expected for this type of instrument.

2.4 *Development of a Synthetic Background Spectrum*

Three methods were used to generate background (I_0) spectra so that the single-beam field spectra could be converted to absorbance files. One method used a field spectrum collected at the end of the monitoring period that did not contain any spectral features due to SF₆. This method is similar to using an upwind background spectrum as described in Section 4.3 of the *FT-IR Open-Path Monitoring Guidance Document*. File #d0224306 was used for these purposes. With this method, the spectral features of the atmospheric gases and the instrument response essentially cancel out, leaving only the absorption features due to SF₆. When this is the case, quantitative data can only be obtained for the released tracer gas. The remaining absorption features of the atmospheric gases represent the difference between the concentrations in the other field spectra relative to those in spectrum #d0224306.

The second method used to generate an I_0 spectrum was to create a synthetic background spectrum from a representative field spectrum. File #d0224306 was again used for this purpose. A synthetic background spectrum was created from this file using the method described in Section 4.2 of the *FT-IR Open-Path Monitoring Guidance Document*. This synthetic background spectrum was created from 650 to 4500 cm⁻¹ so that the entire spectrum could be analyzed for the target gas and other atmospheric gases.

The third method used to generate an I_0 spectrum fitted a series of segmented polynomial curves to each single-beam spectrum as part of an automated analysis method using an innovative nonlinear algorithm.⁶

No differences were found in the reported concentrations of SF₆ in the absorbance files created by using either file #d0224306 as the background spectrum or the synthetic background spectrum. The I_0 spectrum generated by the nonlinear algorithm was used only during the nonlinear analyses and was not used to generate absorbance files for subsequent analysis by another method. All of the concentration data reported from the

Classical Least Squares (CLS) analyses were computed from absorbance files created by using a synthetic background spectrum.

2.5 Examination of the Range of Absorbance Values Exhibited by the SF₆ Spectral Features

The tracer gas SF₆ has a relatively high absorption coefficient at the peak maximum at approximately 948 cm⁻¹. Because of the inherent nonlinear response of an OP/FTIR system over a wide range of absorbance values, it is imperative to determine the range of absorbance values exhibited in the field spectra. The tracer gas was not detected in all of the field spectra in this subset. For those spectra in which SF₆ was not detected, the net absorbance at 948 cm⁻¹ was approximately 0.02 absorbance units. This positive value was due to a small water vapor absorption band. The minimum net absorbance at 948 cm⁻¹ in those spectra that did exhibit a detectable quantity of SF₆ was 0.145 absorbance units. The maximum net absorbance for SF₆ (0.185) was found for file #d0224291. The concentration of SF₆ found in this file exhibited a sharp increase relative to the concentrations in the other files and did not fit the trend exhibited by the preceding data files. For those spectra that did fit the overall trend, the maximum net absorbance was 0.164 (file #d0224002). The range of absorbance values (0.145 to 0.185) observed for this subset of data is relatively small and should not result in a severe nonlinear response in absorbance with respect to changes in concentration, assuming that the detector was operating in a linear mode.

2.6 *Identification of Any Interfering Species*

The absorption spectra that were created using the synthetic background spectrum as I_0 were visually inspected for interfering or unidentified species. Only the tracer gas SF₆ and common atmospheric gases were identified in the absorption spectra. Water vapor was the only interfering species that exhibited spectral features in the wavenumber region used to analyze for SF₆.

2.7 *Generation of Relevant Reference Spectra from the HITRAN Database*

Several reference spectra of selected atmospheric gases, including CH₄, N₂O, CO, CO₂, and H₂O, were generated from the HITRAN database using Etrans (Ontar Corporation, North Andover, MA). Spectra of the individual target gases were originally generated at a nominal 1-cm⁻¹ resolution with triangular apodization at a temperature of 295K and atmospheric pressure of 760 Torr. Each spectrum was generated at a pathlength of 108 m. An absorption file compatible with Grams/32 (Galactic, Salem, NH) was selected as the output from Etrans. After the original set of reference spectra were generated and used in the CLS analysis, analyses conducted by SpectraSoft Technology revealed that the true resolution of the instrument was 1.462 cm⁻¹. A new set of reference spectra was generated at 1.462-cm⁻¹ resolution and the CLS analyses were repeated.

2.8 *Inspection of the Absorbance Files for Wavenumber Shifts and Changes in Resolution*

Prior to analyzing the data with the CLS methods, the reference spectra were compared to the field absorption spectra for evidence of wavenumber shifts. If any wavenumber shifts were found, the reference spectra were adjusted by using the “peak

align” subroutine in Grams/32. The data point density and spacing of the reference and field spectra were matched by using the “interpolate” routine in Grams/32.

The innovative nonlinear analysis method automatically determines the wavenumber shift in the single-beam field spectra relative to the reference spectra generated from Etrans and calculates the actual spectral resolution of the field spectra. The field spectra exhibited a constant 0.5-cm^{-1} shift relative to the reference spectra generated from Etrans. The actual spectral resolution was relatively constant, but, at a value of $1.462 \pm 0.011 \text{ cm}^{-1}$, was significantly higher than expected for an instrument operating at a nominal 1-cm^{-1} resolution. These data are plotted in Figure 9 and imply that, although the instrument was stable, it might not have been operating properly initially at the beginning of the field study.

2.9 Development and Evaluation of an Analysis Method

The method used to determine the concentrations of target gases from OP/FTIR spectra should account for the inherent nonlinearities in the response of the instrument. There are two types of nonlinearity that can affect the accuracy of the concentration data reported by an OP/FTIR monitor: detector nonlinearity and nonlinearity in absorbance. Evidence of detector nonlinearity was discussed in Section 2.1.1 of this report and, unfortunately, no analysis method can account for this type of nonlinearity. The OP/FTIR system can also exhibit a nonlinearity in the change in absorbance with respect to changes in concentration. This nonlinearity is due to the convolution of the instrument line shape function, which is influenced by the resolution and apodization used to collect and process the interferograms, with the spectral data. The nonlinearity with respect to changes in absorbance can be accounted for by using a multilevel calibration model or some other type of nonlinear analysis algorithm. A multilevel CLS analysis and an innovative nonlinear algorithm have been previously applied successfully to APPCD field data collected at a concentrated swine production facility to account for the nonlinearity

in the absorbance over the wide range of concentration-pathlength products of the target gases detected at that site.

The spectral data from the Augusta study were analyzed using four different methods. Three methods were based on a CLS analysis using AutoQuant3 (MIDAC, Irvine, CA), while the fourth used an innovative nonlinear algorithm developed by Dr. Bill Phillips of SpectraSoft Technology (Tullahoma, TN).⁶ A matrix of the wavenumber ranges, target gases, and interfering species is given in Table 1. Different sets of reference spectra were used for the three CLS methods. One CLS method used a set of reference spectra from the Hanst 1.0-cm⁻¹ spectral library (Infrared Analysis, Inc., Anaheim, CA). Another CLS method used a set of reference spectra of atmospheric gases generated from the HITRAN database using Etrans and a reference spectrum of SF₆ from the NIST Standard Reference Database 79 (Gaithersburg, MD). For this method, the spectra of the atmospheric gases were generated at a concentration-pathlength product that produced absorbance values of the analytical IR bands near the median of those found in the field spectra. The third CLS method also used a set of reference spectra of the atmospheric gases generated from the HITRAN database using Etrans and a reference spectrum of SF₆ from the NIST database. A multilevel calibration was used for this method, with reference spectra of the atmospheric gases generated at concentration-pathlength products corresponding to 10% lower, 10% higher, the median, and midpoints between the median and the high and low absorbance values of those in the field spectra. The concentration-pathlength products used for this multilevel CLS analysis are given in Table 2.

Table 1. Analysis Region Matrix for CLS Analyses

Analyte	900.20–980.70 cm ⁻¹	2083.9–2223.3 cm ⁻¹	2881.9–2929.2 cm ⁻¹
SF ₆	•		
H ₂ O(1)	•		
CO		•	
N ₂ O		•	
H ₂ O(2)		•	
CH ₄			•
H ₂ O(3)			•

Table 2. Concentration Pathlength-Products (ppm-m) for Multilevel CLS Analysis

Analyte	Low -10%	Midpoint 1	Median	Midpoint 2	High +10%
SF ₆	—	—	1	—	—
H ₂ O(1)	1080000	1350000	1620000	1890000	2160000
CO	108	135	162	189	216
N ₂ O	31.32	32.94	34.56	36.18	37.8
H ₂ O(2)	1080000	1350000	1620000	1890000	2160000
CH ₄	140.4	237.6	334.8	432	540
H ₂ O(3)	1080000	1350000	1620000	1890000	2160000

2.10 Comparison of the Concentration Values Generated by the Automated Multivariate Data Analysis Method to Manual Comparison Method or Advanced Nonlinear Algorithms

Selected absorption files were analyzed by the manual comparison method described in Section 2.6.5.3.1 of the *FT-IR Open-Path Monitoring Guidance Document* to check the output of the automated CLS method. An example of this procedure is given in Table 3 for SF₆ for data files that represent the extremes in the reported concentration values.

Table 3. Reported Concentration Values of Selected Files Using the Comparison and Multilevel CLS Methods

File Number	Comparison Method (ppm)	Multilevel CLS (ppm)
d0224002	0.054	0.047
d0224089	0.036	0.028
d0224291	0.061	0.059
d0224305	0.006	0

As shown in Table 3, the reported values for SF₆ from the multilevel CLS analysis are very similar to those determined by using the comparison method for these selected files. There is a slight positive bias in the concentration values determined by the comparison method because of interference from a water vapor band. Otherwise, the two methods are comparable for these representative data files.

More extensive comparisons were made between the single-level CLS analyses using reference spectra from the Hanst spectral library and those generated from Etrans, the multilevel CLS analysis with reference spectra generated from Etrans, and an analysis using the innovative nonlinear algorithm. Dr. Phillips of SpectraSoft Technology performed the nonlinear analysis under a subcontractual agreement with ManTech under WA-IV-119. The concentration values of SF₆ and selected atmospheric gases determined by using the different analysis methods are given in Attachments 1 – 4. The mean concentration values reported from the four different analysis methods are summarized in Table 4. Also included in Table 4 are the results from the original CLS analyses using reference spectra generated from Etrans using a nominal 1-cm⁻¹ resolution.

The mean concentrations of SF₆ reported by each of the analysis methods were nearly identical even though the concentration-pathlength products of the reference spectra for SF₆ were significantly different in the single-level CLS method using the Hanst reference spectrum (66 ppm-m, Abs_{max} = 1.5578) and the other methods, which used a reference spectrum from the NIST database (1 ppm-m, Abs_{max} = 0.02811). The mean concentrations of CH₄ during this monitoring period were similar for the

Table 4. Mean Concentration Values (ppm) for SF₆ and Selected Atmospheric Gases

Method	SF ₆	CH ₄	CO	N ₂ O	H ₂ O (1)	H ₂ O (2)	H ₂ O (3)	CO ₂
CLS Hanst, Single Level	0.04	3.006	2.348	0.378	—	—	—	—
CLS Etrans, Single Level (1 cm ⁻¹)	0.04	2.256	1.312	0.321	11820	12464	11539	—
CLS Etrans, Single Level (1.462 cm ⁻¹)	0.04	2.68	2.058	0.35	15531	15841	12719	—
CLS Etrans, Multilevel (1 cm ⁻¹)	0.04	2.243	1.267	0.321	11519	11317	11344	—
CLS Etrans, Multilevel (1.462 cm ⁻¹)	0.04	2.671	2.161	0.348	15095	16492	12328	—
Nonlinear	0.04	2.758	2.208	0.382	9496	—	—	519.2

two CLS methods using reference spectra generated from Etrans at 1.462-cm⁻¹ resolution, but were slightly higher for the nonlinear algorithm and the CLS method using the Hanst reference spectra. There were significant differences between the two CLS methods using Etrans reference spectra generated at either a nominal 1-cm⁻¹ resolution or 1.462-cm⁻¹ resolution. In each case, the CLS method using the nominal 1-cm⁻¹ resolution Etrans reference spectra under-reported the mean concentration.

The mean concentrations of CO and N₂O reported by the nonlinear algorithm were slightly higher than those reported by the CLS methods using the 1.462-cm⁻¹ Etrans reference spectra, whereas the water vapor concentration reported by the nonlinear algorithm was lower than that reported by the CLS methods. The reasons for these discrepancies are not known, but could include differences in developing the synthetic background spectrum for the CLS analyses and the fitted polynomial background for the nonlinear algorithm or the nonlinearity in the data caused by the saturated detector. The cause of these discrepancies has not been investigated further. The mean concentration for CO₂ reported from the nonlinear algorithm was 519.2 ppm, which is slightly higher than normal ambient levels. The concentration of CO₂ was not reported for the CLS methods because of the difficulties in analyzing for this gas in 1-cm⁻¹ resolution spectra due to spectral overlap with CO and water vapor.

2.11 Development of Relevant Control Charts

As discussed above in Sections 2.2 and 2.3, control charts were developed for the signal strength and the random baseline noise, respectively. Control charts were also developed for the concentrations of selected atmospheric gases over time. These charts were developed from the concentration data reported by the multilevel CLS method and are given in Figures 10 – 14.

The reported concentrations of SF₆ fluctuated between 28 and 50 ppb throughout most of the monitoring period and was relatively constant (38 ± 9 ppb) except for a sharp increase that was observed in files d0224290 and d0224291 (see Figure 10). The concentration of SF₆ decreased rapidly after file # d0224291 and was not detected in files after d0224300.

The reported concentration of CH₄ was more variable, 2.671 ± 0.729 ppm (see Figure 11). The path-averaged concentration ranged from near or slightly below ambient background levels to more than 5.5 ppm. Although the concentration of SF₆ was relatively constant throughout the monitoring period, the CH₄ concentrations increased rapidly during three separate episodes. No other gases exhibited increases in concentrations during these time periods.

The path-averaged concentration of carbon monoxide was relatively high (2.161 ± 0.181) for ambient measurements. High concentrations of CO were detected inside the spectrometer of the ETG system evaluated at RTP, NC. The CO concentration in this instrument increased over time. Purging the spectrometer box with dry N₂ removed the CO from the system. This procedure should be done on all ETG systems in the field. The concentration of CO was relatively constant, but showed a steady increase near the end of the monitoring period (see Figure 12).

The concentrations of N₂O were relatively constant (0.348 ± 0.010 ppm) and slightly higher than expected ambient levels (see Figure 13). Slight increases in the N₂O concentrations were observed near the end of the monitoring period. Assuming that the ambient concentrations of N₂O were constant, these results indicate that the instrument was stable throughout this monitoring period.

As a quality control check, the water vapor concentration was measured in three different regions. Region 1 corresponds to the analysis region used for SF₆ between 900.20 and 980.70 cm⁻¹; region 2 corresponds to the analysis region used for CO and N₂O between 2083.90 and 2223.3 cm⁻¹; and region 3

corresponds to the analysis region used for CH₄ between 2881.9 and 2929.2 cm⁻¹. The concentrations of water vapor reported for each region were in close agreement and on average were approximately 14,500 ppm. This path-averaged concentration is equivalent to approximately 11 Torr. If the water vapor concentration was measured by some independent means during the field study, these data could be used to assess the accuracy of the OP/FTIR data.

3.0 Conclusions and Recommendations

The QC procedures used to assess the instrument operation during the Augusta field study indicate that the instrument was stable throughout the monitoring period represented by the subset of data analyzed for this work assignment. However, these procedures revealed significant problems in the performance of the system and in the initial setup of the instrument. The single-beam field spectra exhibited a wavenumber shift of 0.5 cm⁻¹ relative to the reference spectra generated from Etrans. Also, the instrument resolution was calculated to be approximately 1.46 cm⁻¹, instead of the selected value of 1.0 cm⁻¹. In addition to these problems, all of the single-beam spectra from this subset of data exhibit evidence of detector saturation. As a result, the instrument was most likely operating in a nonlinear mode during this study, which makes the accuracy of the reported concentration values highly questionable. Although different analysis methods and algorithms can be used to account for nonlinearities due to the convolution of the instrument response function on the spectral data, methods to correct for the nonlinearities due to detector saturation do not exist. The likelihood of detector saturation can be minimized by examining the single-beam spectra during the initial instrument setup. Procedures for the initial instrument setup are given in EPA-sponsored guidance documents^{1,2} and ASTM standards.^{3,4} These documents should be reviewed and adhered to during future studies with the OP/FTIR system. In addition to these documents, an example of a USEPA audit on an OP/FTIR field study, including an extensive audit questionnaire, has been presented and is very helpful in applying many of the operating principles and quality control procedures discussed in these documents to OP/FTIR field data.⁷

The comparison of the data collected by the roof vent OP/FTIR system to those obtained by manual bag sampling with subsequent analysis by FTIR spectrometry is of particular interest to the APPCD. Because of the uncertainties in the OP/FTIR data, conclusions drawn from this comparison should be made with the caveat that the OP/FTIR instrument was most likely operating in a nonlinear mode due to detector saturation.

4.0 Literature Cited

1. Russwurm, G.M. and Childers, J.W., *FT-IR Open-Path Monitoring Guidance Document*, 3rd Edition, TR-4423-99-03, ManTech Environmental Technology, Inc., Research Triangle Park, NC, June, 1999.
2. Compendium of Methods for the Determination of Toxic Organic Compounds in Ambient Air, 2nd Edition, EPA/625/R-96/010b, Center for Environmental Research Information, Office of Research & Development, U.S. Environmental Protection Agency, Cincinnati, OH 45268, January 1997.
3. E 1865 Standard Guide for Open-Path Fourier Transform Infrared (OP/FT-IR) Monitoring of Gases and Vapors in Air, Annual Book of ASTM Standards, Vol 03.06, American Society for Testing and Materials, West Conshohocken, PA.
4. E 1982 Standard Practice for Open-Path Fourier Transform Infrared (OP/FT-IR) Monitoring of Gases and Vapors in Air, Annual Book of ASTM Standards, Vol 03.06, American Society for Testing and Materials, West Conshohocken, PA.
5. Griffiths, P.R. and deHaseth, J.A., *Fourier Transform Infrared Spectrometry*, John Wiley & Sons, Inc.(1986), pp. 56-65.
6. Phillips, B., Moyers, R., and Lay, L.T., "Improved FTIR Open Path Remote Sensing Data Reduction Technique," Proceedings of Optical Sensing for Environmental and Process Monitoring, VIP-37, Air & Waste Management Association, Pittsburgh, PA, 1995, pp. 374-388.
7. Childers, L.O., "The USEPA QA Auditor is Scheduled for a Visit. What Can I Expect?", Proceedings of Optical Remote Sensing for Environmental and Process Monitoring, VIP-55, Air & Waste Management Association, Pittsburgh, PA, 1996, pp. 127-138.

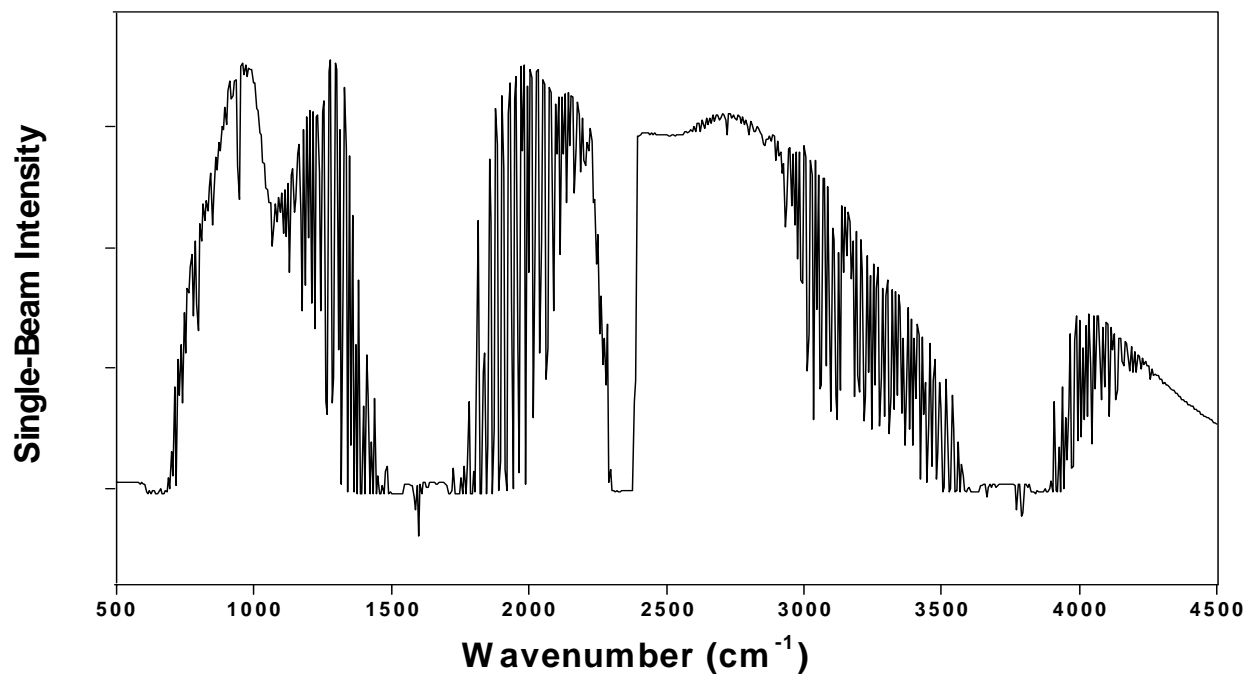

Figure 1. Single-beam OP/FTIR spectrum collected during the Augusta study with a 108-m pathlength.

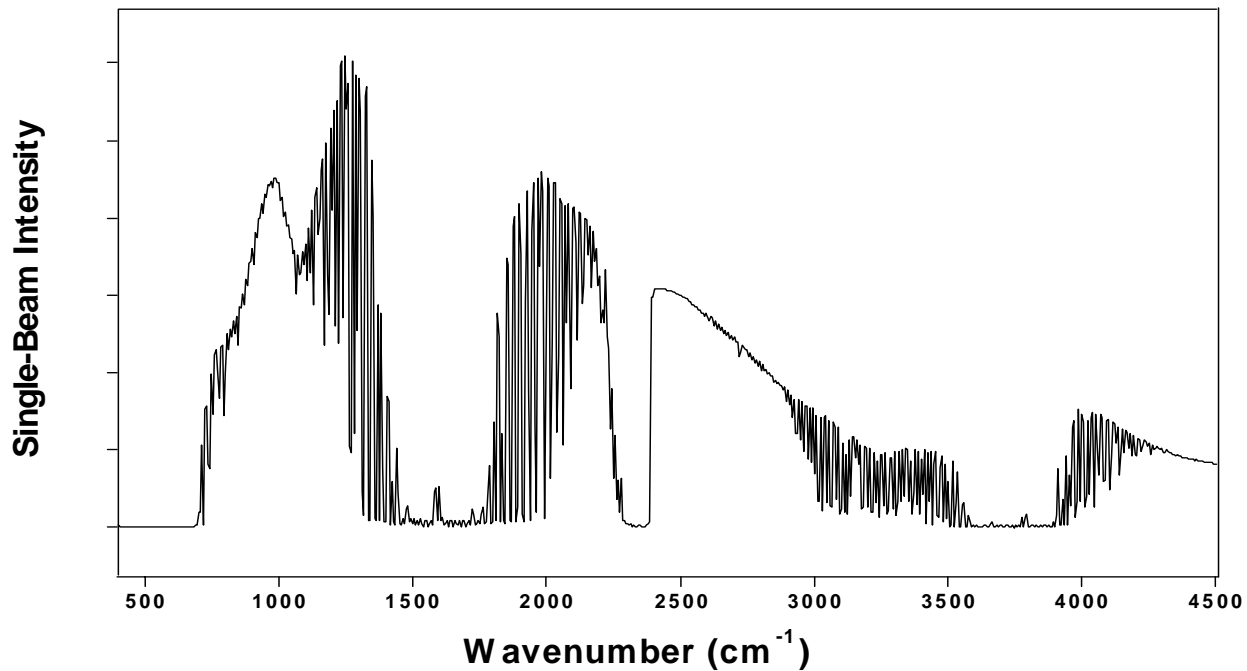

Figure 2. Single-beam OP/FTIR spectrum collected at Research Triangle Park with a 414-m pathlength.

Signal Strength at 985 cm⁻¹

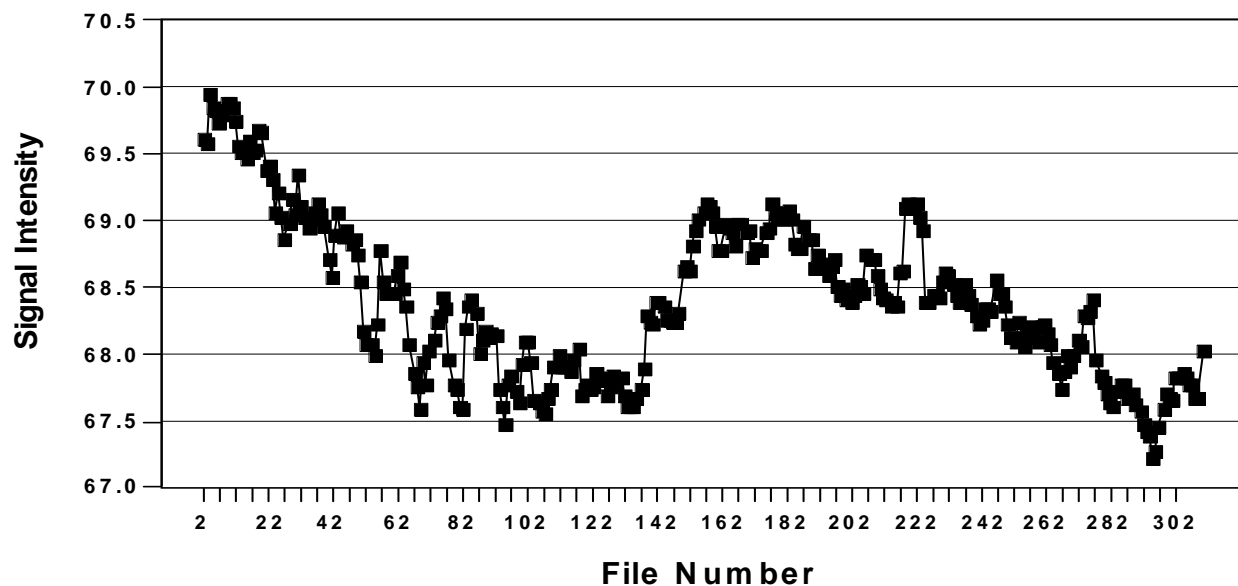

Figure 3. Single-beam signal intensity (in arbitrary units) at 985 cm⁻¹.

Relative Signal Strength (2500/985)

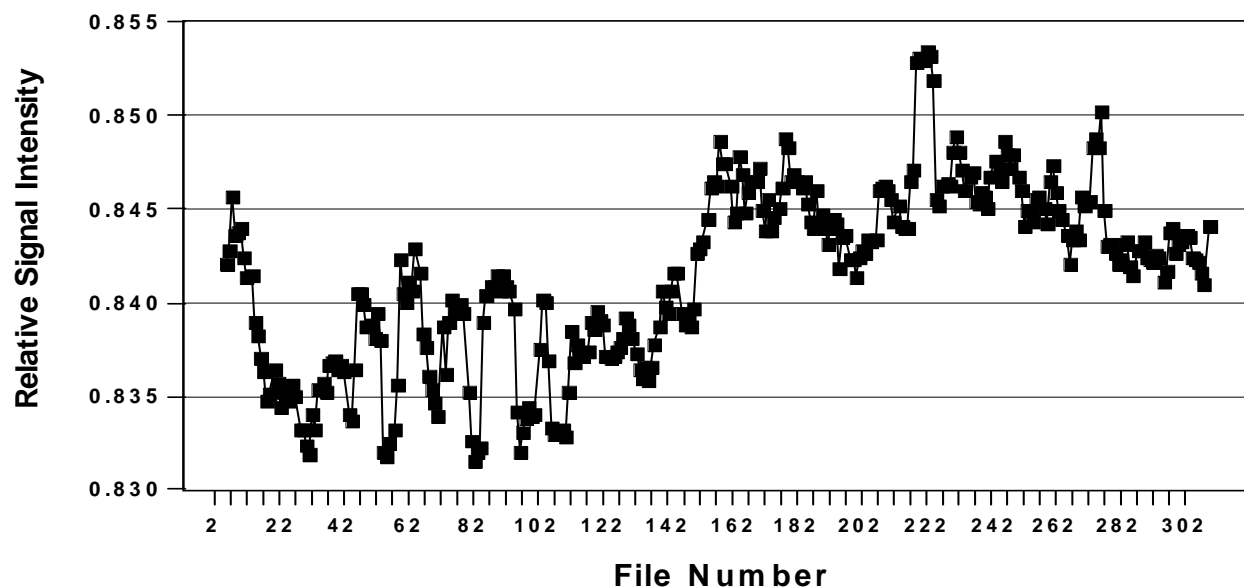

Figure 4. Relative single-beam signal intensity at 2500 cm⁻¹ ratioed to that at 985 cm⁻¹.

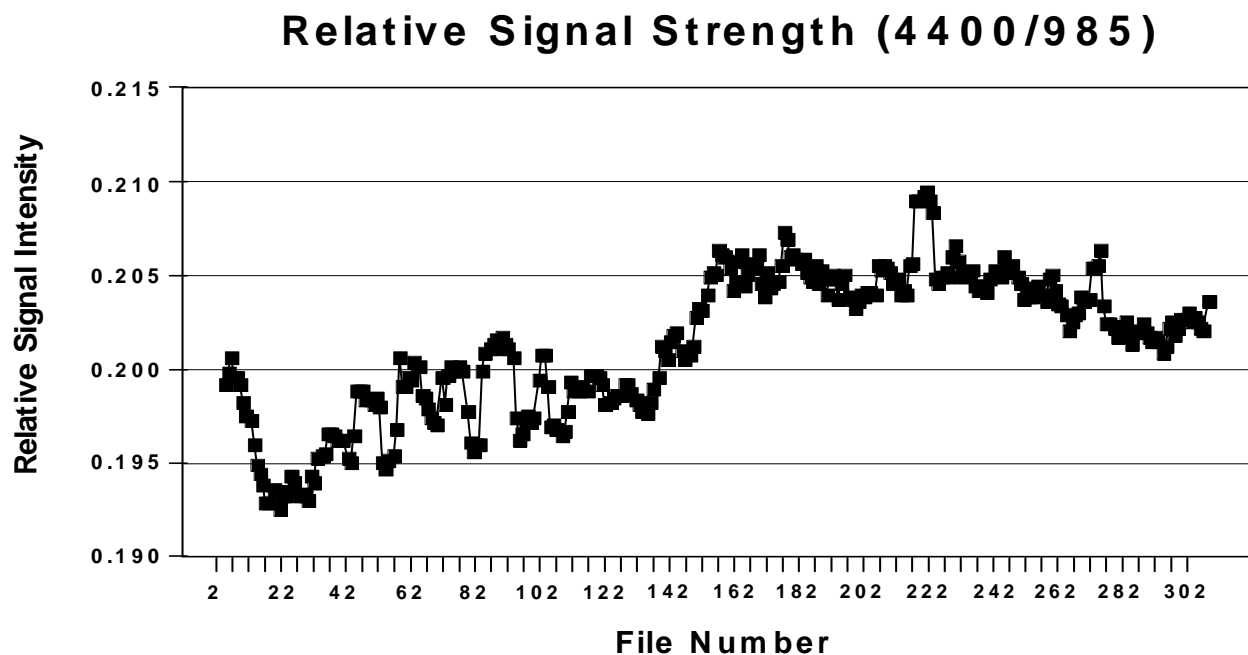

Figure 5. Relative single-beam signal intensity at 4400 cm⁻¹ ratioed to that at 985 cm⁻¹.

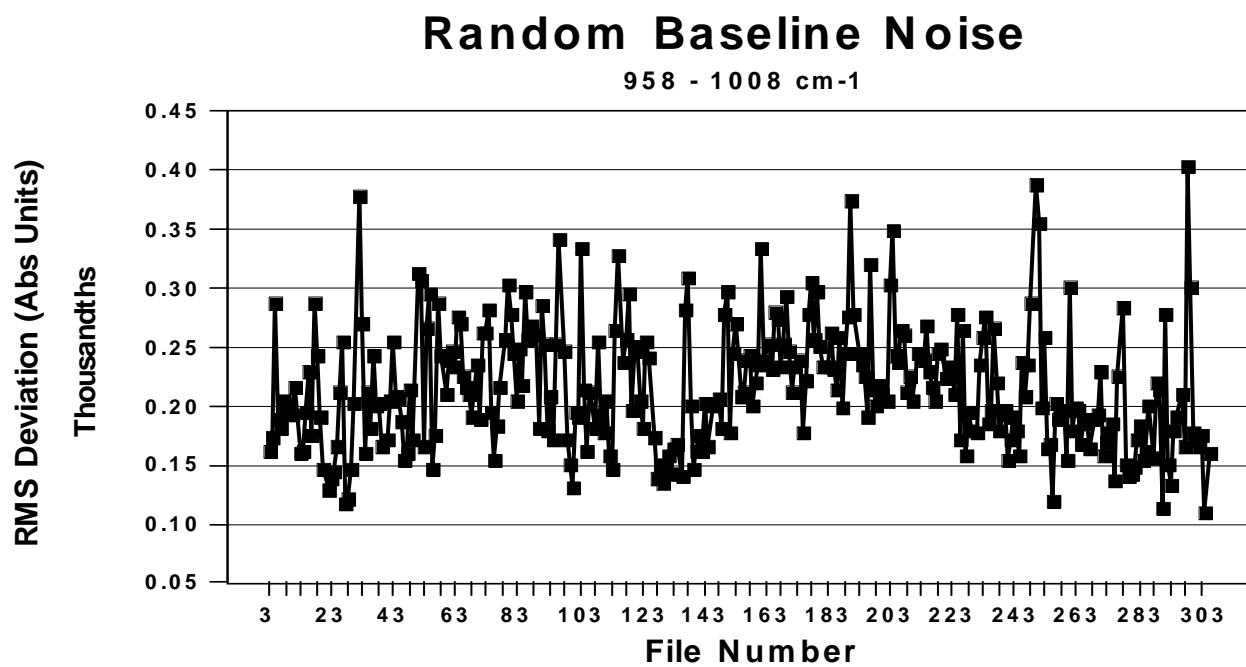

Figure 6. Random baseline noise measured between 958 and 1008 cm⁻¹.

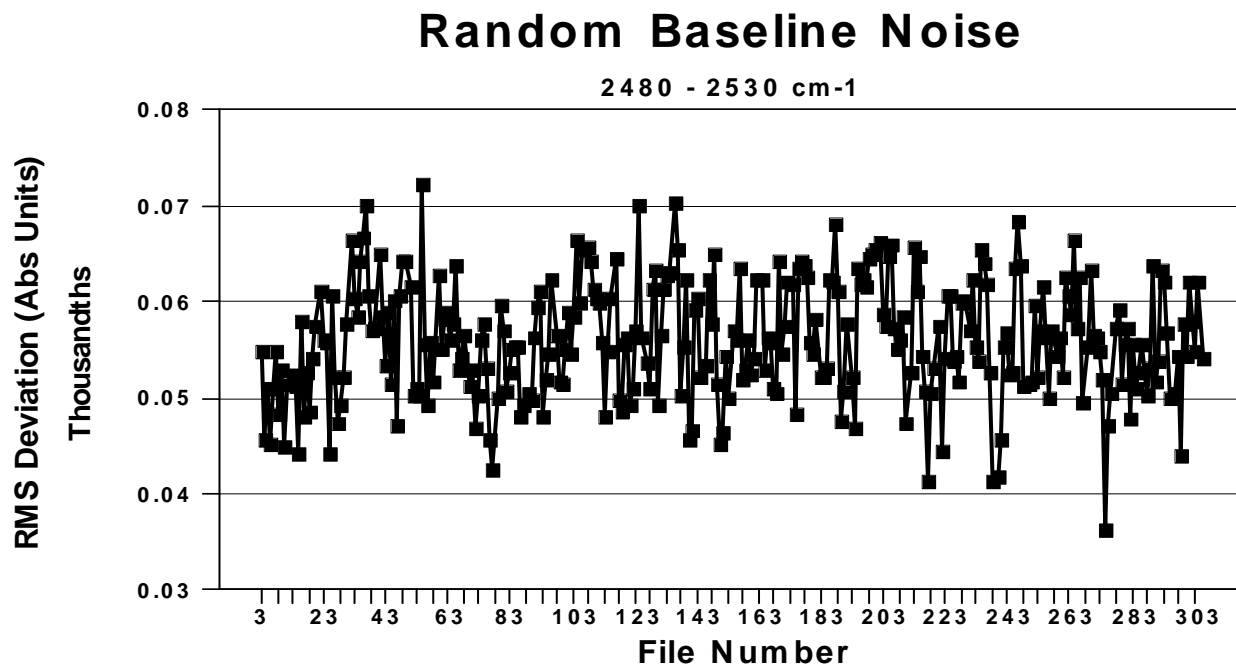

Figure 7. Random baseline noise measured between 2480 and 2530 cm^{-1} .

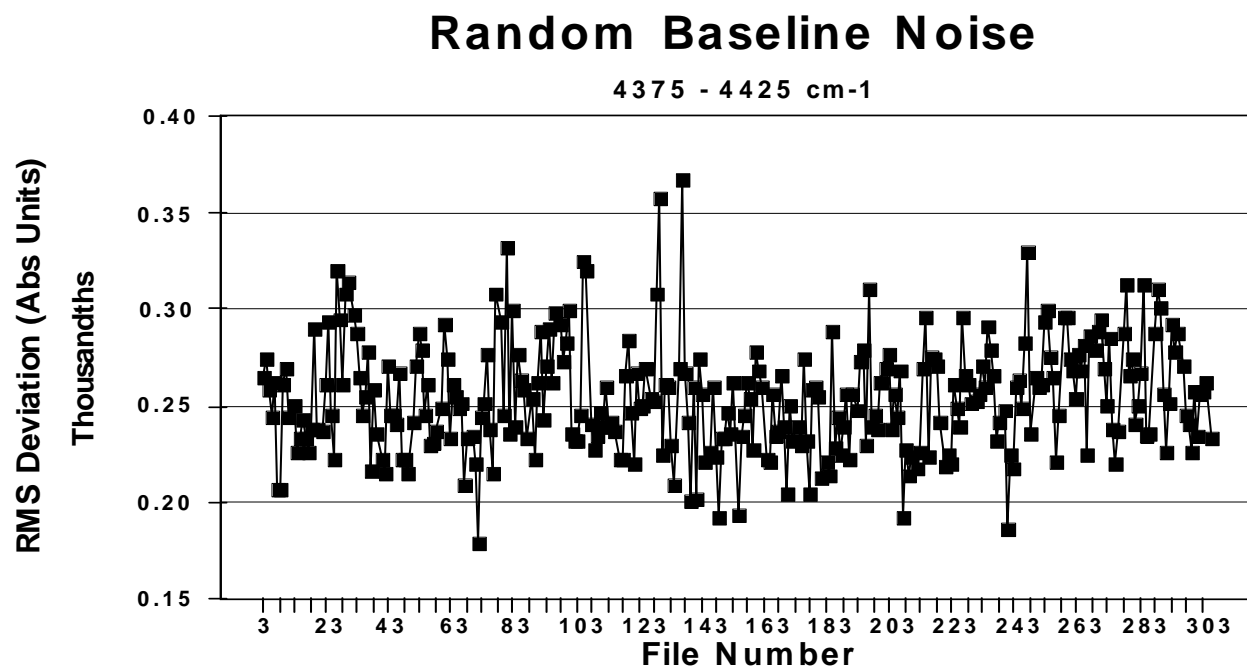

Figure 8. Random baseline noise measured between 4375 and 4425 cm^{-1} .

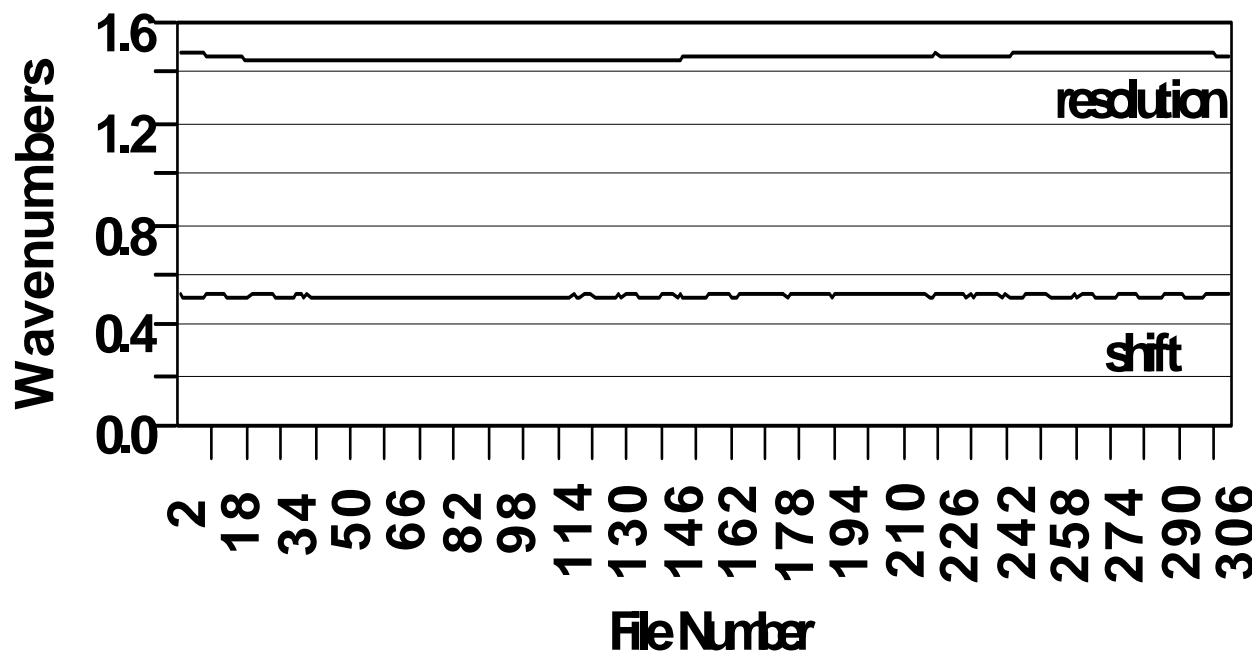

Figure 9. Measurement of the resolution and wavenumber shift calculated from the nonlinear algorithm.

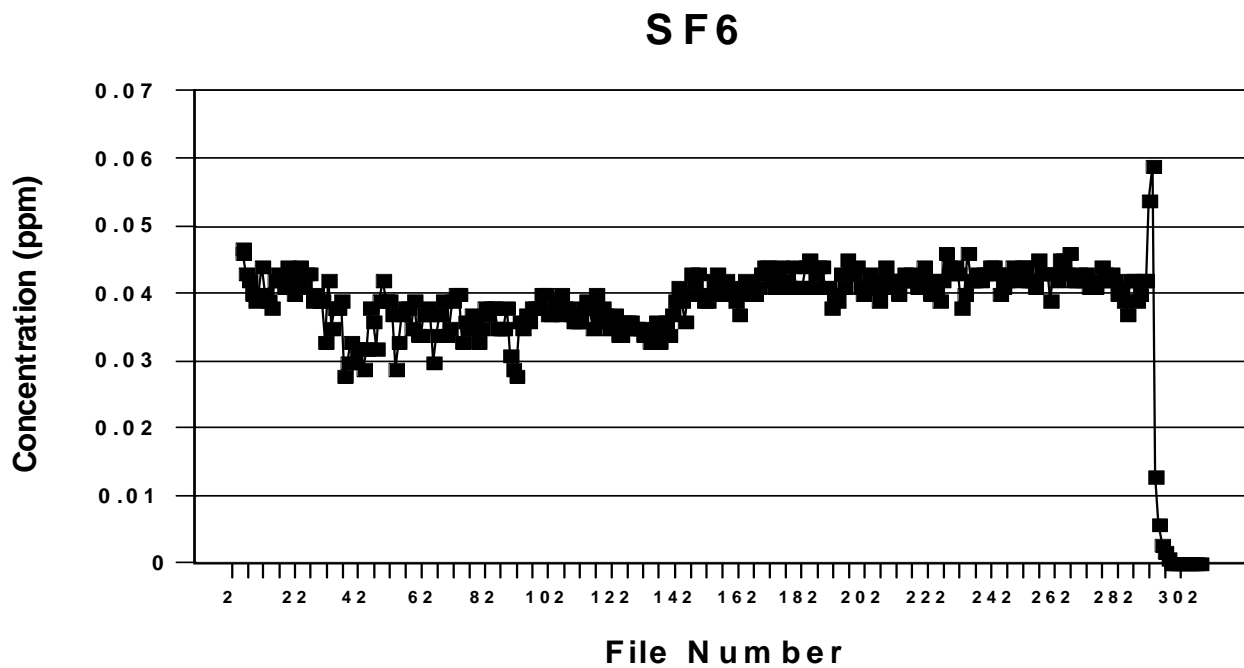

Figure 10. Concentration of SF₆ Determined from Multilevel CLS Analysis.

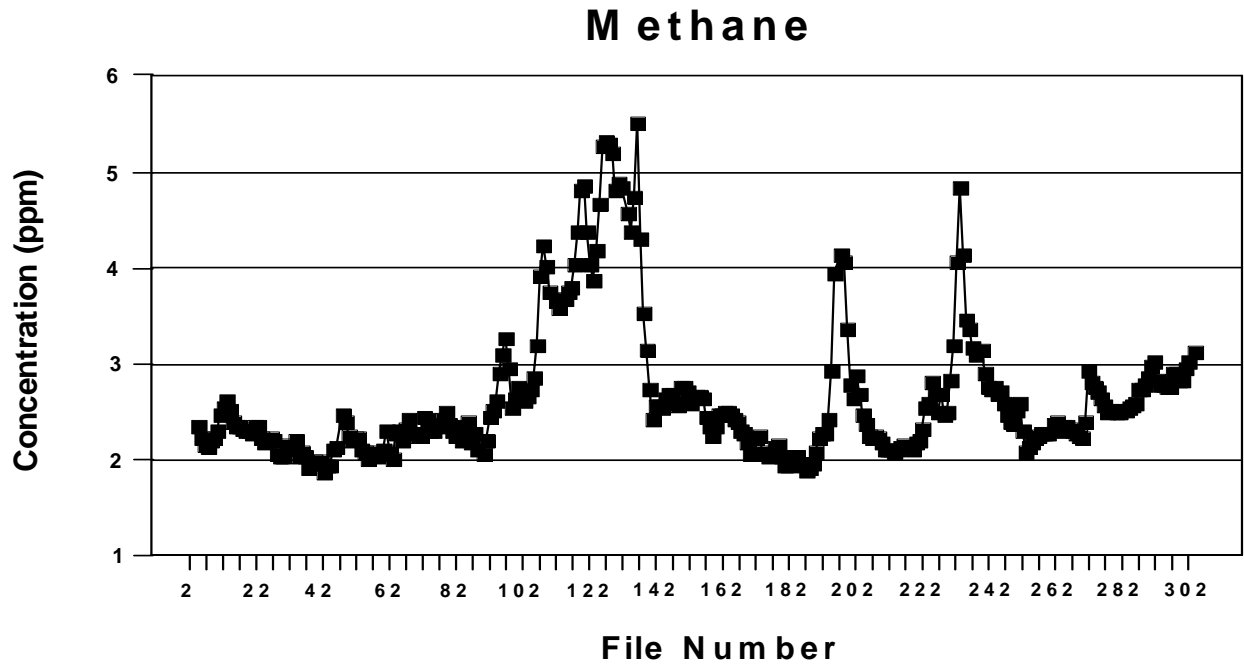

Figure 11. Concentration of CH₄ Determined from Multilevel CLS Analysis.

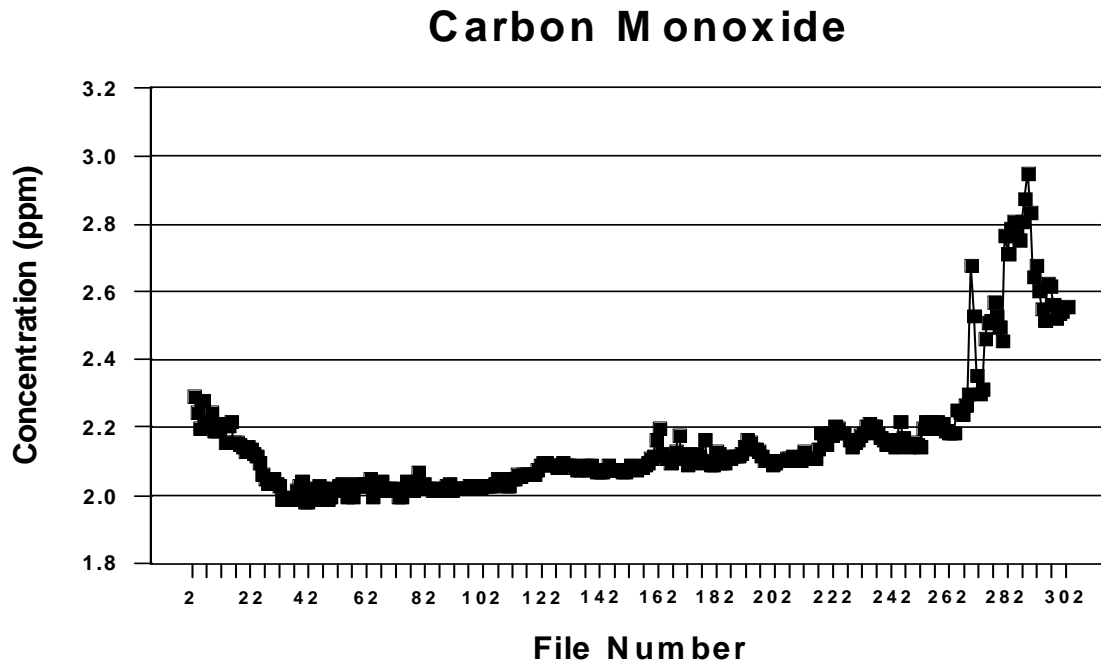

Figure 12. Concentration of CO Determined from Multilevel CLS Analysis.

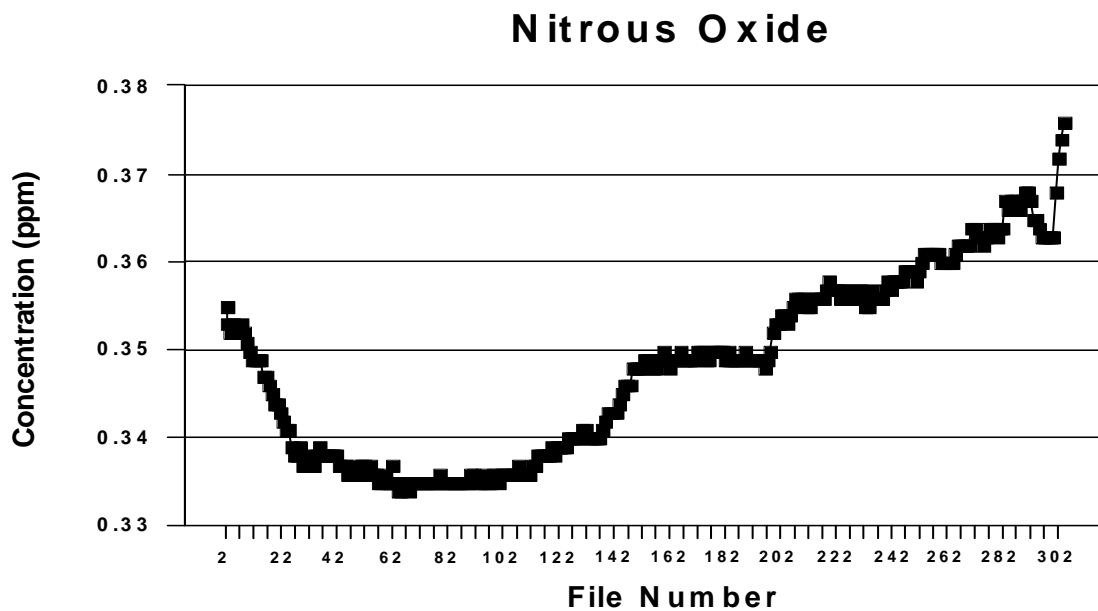

Figure 13. Concentration of N₂O Determined from Multilevel CLS Analysis.

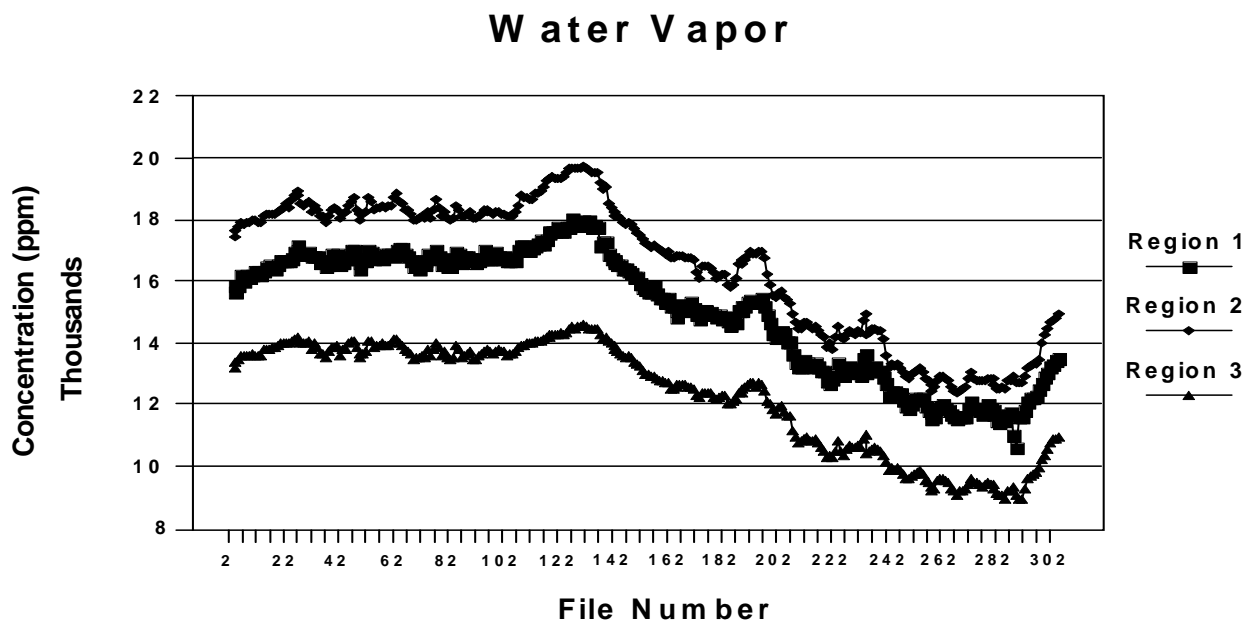

Figure 14. Concentration of H₂O Determined from Multilevel CLS Analysis.

Attachment 1

Concentration Data from CLS Single Level Calibration Using Hanst 1.0 cm⁻¹ Reference Spectra

CLS Single Level Calibration Using Hanst 1.0 cm⁻¹ Reference Spectra

File	CH ₄	CO	N ₂ O	SF ₆	H ₂ O(1)	H ₂ O(2)	H ₂ O(3)
2	2.645	2.487	0.384	0.051	14540	12863	12074
3	2.508	2.433	0.383	0.049	14707	12963	12233
4	2.416	2.372	0.381	0.046	14629	13017	12352
5	2.398	2.472	0.383	0.045	14828	13110	12424
6	2.459	2.403	0.382	0.043	14650	13083	12442
7	2.508	2.385	0.382	0.042	14743	13085	12402
8	2.595	2.435	0.383	0.043	14693	13089	12383
9	2.786	2.367	0.382	0.047	14852	13141	12437
10	2.864	2.360	0.381	0.043	14891	13137	12467
11	2.946	2.381	0.381	0.042	14824	13106	12425
12	2.849	2.388	0.380	0.041	14592	13126	12447
13	2.698	2.321	0.379	0.045	14880	13221	12605
14	2.643	2.378	0.379	0.046	14983	13237	12553
15	2.628	2.395	0.379	0.046	15038	13246	12528
16	2.599	2.325	0.377	0.044	14941	13235	12575
17	2.583	2.327	0.377	0.048	14953	13241	12618
18	2.584	2.312	0.376	0.045	14962	13286	12647
19	2.553	2.302	0.375	0.043	15002	13302	12728
20	2.631	2.293	0.374	0.045	15095	13348	12721
21	2.624	2.306	0.374	0.048	15132	13381	12736
22	2.503	2.297	0.373	0.044	15029	13346	12704
23	2.432	2.276	0.372	0.047	15126	13427	12785
24	2.495	2.269	0.371	0.046	15233	13460	12844
25	2.459	2.227	0.369	0.042	15256	13491	12922
26	2.309	2.200	0.369	0.044	15244	13463	12825
27	2.28	2.190	0.368	0.043	15036	13398	12757
28	2.269	2.172	0.368	0.043	14996	13385	12751
29	2.411	2.181	0.368	0.036	14836	13391	12755
30	2.361	2.189	0.368	0.045	15106	13393	12748

CLS Single Level Calibration Using Hanst 1.0 cm⁻¹ Reference Spectra (Continued)

File	CH ₄	CO	N ₂ O	SF ₆	H ₂ O(1)	H ₂ O(2)	H ₂ O(3)
31	2.392	2.177	0.368	0.038	14792	13261	12541
32	2.468	2.165	0.367	0.041	14967	13358	12691
33	2.283	2.145	0.367	0.041	14875	13302	12599
34	2.316	2.143	0.367	0.043	14791	13199	12448
35	2.278	2.149	0.368	0.031	14483	13197	12419
36	2.136	2.143	0.369	0.033	14341	13114	12359
37	2.177	2.146	0.367	0.036	14550	13208	12485
38	2.205	2.154	0.368	0.033	14709	13304	12572
39	2.168	2.168	0.367	0.036	14780	13333	12606
40	2.219	2.185	0.368	0.036	14858	13323	12638
41	2.077	2.140	0.368	0.032	14482	13154	12401
42	2.145	2.139	0.368	0.035	14655	13216	12517
43	2.165	2.155	0.367	0.041	14833	13253	12509
44	2.363	2.143	0.367	0.039	14884	13340	12673
45	2.375	2.162	0.368	0.035	14873	13375	12706
46	2.786	2.170	0.366	0.042	15072	13414	12716
47	2.685	2.165	0.366	0.045	14859	13301	12568
48	2.54	2.156	0.366	0.042	14677	13220	12433
49	2.472	2.151	0.367	0.042	14557	13110	12304
50	2.499	2.152	0.366	0.040	14792	13210	12461
51	2.489	2.163	0.368	0.032	14581	13251	12495
52	2.352	2.154	0.367	0.036	14918	13418	12744
53	2.314	2.165	0.367	0.041	14980	13391	12734
54	2.236	2.178	0.367	0.041	14852	13300	12590
55	2.316	2.168	0.367	0.041	14879	13311	12611
56	2.286	2.153	0.367	0.038	14809	13308	12563
57	2.266	2.166	0.366	0.042	14936	13330	12561
58	2.285	2.151	0.366	0.037	14874	13317	12518
59	2.349	2.177	0.367	0.037	14867	13329	12521

CLS Single Level Calibration Using Hanst 1.0 cm⁻¹ Reference Spectra (Continued)

File	CH ₄	CO	N ₂ O	SF ₆	H ₂ O(1)	H ₂ O(2)	H ₂ O(3)
60	2.579	2.171	0.366	0.040	14884	13332	12493
61	2.303	2.174	0.366	0.041	14899	13400	12547
62	2.243	2.158	0.366	0.040	14999	13435	12685
63	2.539	2.166	0.366	0.033	14834	13384	12649
64	2.584	2.194	0.366	0.037	14907	13366	12625
65	2.465	2.153	0.365	0.040	14802	13288	12506
66	2.612	2.159	0.365	0.042	14778	13281	12460
67	2.718	2.167	0.365	0.038	14575	13211	12382
68	2.549	2.196	0.366	0.038	14423	13109	12197
69	2.523	2.169	0.365	0.042	14547	13108	12248
70	2.54	2.158	0.366	0.043	14473	13119	12224
71	2.742	2.167	0.366	0.043	14604	13177	12335
72	2.714	2.170	0.366	0.037	14621	13156	12335
73	2.573	2.159	0.366	0.039	14524	13140	12273
74	2.585	2.151	0.366	0.038	14702	13251	12489
75	2.671	2.156	0.366	0.041	14663	13152	12323
76	2.638	2.158	0.366	0.039	14757	13272	12494
77	2.73	2.185	0.366	0.037	14885	13405	12654
78	2.809	2.155	0.365	0.038	14680	13306	12549
79	2.667	2.168	0.366	0.041	14522	13165	12304
80	2.592	2.225	0.367	0.040	14678	13248	12432
81	2.528	2.171	0.366	0.041	14489	13137	12261
82	2.522	2.182	0.366	0.041	14474	13101	12242
83	2.482	2.170	0.366	0.038	14587	13143	12265
84	2.649	2.163	0.366	0.038	14828	13338	12580
85	2.688	2.160	0.366	0.038	14752	13269	12470
86	2.431	2.168	0.366	0.041	14583	13173	12255
87	2.555	2.163	0.366	0.034	14509	13180	12293
88	2.355	2.162	0.366	0.032	14540	13214	12319

CLS Single Level Calibration Using Hanst 1.0 cm⁻¹ Reference Spectra (Continued)

File	CH ₄	CO	N ₂ O	SF ₆	H ₂ O(1)	H ₂ O(2)	H ₂ O(3)
89	2.288	2.163	0.366	0.031	14412	13248	12405
90	2.47	2.171	0.366	0.039	14564	13150	12248
91	2.747	2.180	0.366	0.038	14478	13158	12250
92	2.841	2.159	0.366	0.040	14595	13191	12332
93	2.942	2.166	0.366	0.039	14597	13205	12382
94	3.287	2.163	0.366	0.041	14808	13294	12485
95	3.509	2.163	0.366	0.041	14632	13240	12415
96	3.718	2.163	0.365	0.041	14798	13300	12502
97	3.341	2.163	0.365	0.043	14694	13250	12428
98	2.877	2.171	0.366	0.043	14666	13214	12376
99	2.975	2.169	0.367	0.040	14748	13259	12432
100	3.126	2.169	0.367	0.040	14717	13263	12456
101	3.025	2.164	0.366	0.042	14718	13226	12392
102	2.947	2.164	0.366	0.042	14712	13225	12431
103	3.014	2.170	0.366	0.043	14633	13190	12352
104	3.091	2.171	0.367	0.040	14589	13208	12394
105	3.219	2.172	0.366	0.041	14678	13207	12394
106	3.633	2.173	0.367	0.041	14627	13265	12460
107	4.46	2.173	0.367	0.040	14838	13360	12611
108	4.815	2.174	0.366	0.039	14946	13438	12638
109	4.549	2.181	0.367	0.039	14971	13409	12633
110	4.244	2.175	0.367	0.039	14913	13408	12644
111	4.139	2.172	0.367	0.042	14915	13403	12644
112	4.052	2.171	0.366	0.043	14945	13396	12649
113	4.162	2.172	0.367	0.041	14989	13441	12701
114	4.182	2.176	0.367	0.038	15018	13451	12725
115	4.255	2.183	0.367	0.043	15172	13483	12741
116	4.299	2.180	0.368	0.040	15044	13512	12787
117	4.581	2.184	0.368	0.041	15187	13598	12829

CLS Single Level Calibration Using Hanst 1.0 cm⁻¹ Reference Spectra (Continued)

File	CH ₄	CO	N ₂ O	SF ₆	H ₂ O(1)	H ₂ O(2)	H ₂ O(3)
118	4.948	2.183	0.368	0.040	15355	13631	12850
119	5.45	2.185	0.368	0.039	15378	13639	12891
120	5.51	2.181	0.368	0.040	15399	13653	12933
121	4.957	2.186	0.368	0.041	15438	13627	12898
122	4.567	2.199	0.368	0.037	15388	13629	12871
123	4.38	2.216	0.369	0.038	15330	13630	12864
124	4.73	2.225	0.369	0.039	15448	13656	12815
125	5.264	2.222	0.369	0.039	15518	13731	12876
126	5.967	2.210	0.369	0.039	15536	13806	12978
127	6.026	2.213	0.370	0.039	15711	13810	13062
128	6.001	2.213	0.370	0.039	15623	13803	13053
129	5.908	2.203	0.370	0.038	15591	13798	13070
130	5.454	2.202	0.370	0.038	15623	13797	13102
131	5.518	2.215	0.370	0.037	15664	13839	13146
132	5.468	2.210	0.370	0.037	15570	13832	13143
133	5.173	2.210	0.370	0.038	15636	13783	13089
134	4.964	2.212	0.370	0.039	15469	13756	13086
135	5.376	2.203	0.370	0.037	15494	13728	13073
136	6.26	2.200	0.370	0.038	15467	13735	13092
137	4.888	2.197	0.370	0.039	15112	13548	12897
138	4.01	2.210	0.370	0.037	15094	13491	12814
139	3.55	2.218	0.370	0.040	15199	13505	12850
140	3.089	2.225	0.372	0.042	14985	13373	12712
141	2.736	2.238	0.373	0.045	14941	13341	12628
142	2.891	2.229	0.373	0.043	14823	13288	12624
143	2.902	2.220	0.373	0.039	14768	13220	12505
144	2.857	2.218	0.373	0.043	14759	13209	12489
145	2.988	2.222	0.373	0.046	14803	13164	12405
146	3.04	2.232	0.374	0.046	14698	13100	12347

CLS Single Level Calibration Using Hanst 1.0 cm⁻¹ Reference Spectra (Continued)

File	CH ₄	CO	N ₂ O	SF ₆	H ₂ O(1)	H ₂ O(2)	H ₂ O(3)
147	3.044	2.246	0.375	0.046	14712	13080	12292
148	2.941	2.232	0.375	0.043	14632	13093	12348
149	2.887	2.234	0.375	0.042	14576	13056	12301
150	3.118	2.233	0.376	0.042	14403	12969	12145
151	3.131	2.231	0.376	0.043	14470	12935	12144
152	3.068	2.227	0.377	0.046	14368	12890	12043
153	2.93	2.229	0.376	0.046	14326	12810	11941
154	3.004	2.254	0.377	0.044	14175	12740	11858
155	3.007	2.241	0.377	0.044	14167	12717	11847
156	2.989	2.236	0.377	0.045	14161	12698	11823
157	2.761	2.245	0.377	0.044	14273	12722	11861
158	2.66	2.247	0.376	0.043	14024	12675	11790
159	2.556	2.251	0.377	0.042	13915	12636	11735
160	2.663	2.263	0.377	0.040	13892	12613	11699
161	2.805	2.280	0.378	0.043	13894	12579	11652
162	2.788	2.290	0.378	0.045	14039	12604	11614
163	2.809	2.346	0.379	0.044	13873	12490	11488
164	2.832	2.383	0.380	0.043	13821	12491	11474
165	2.791	2.298	0.379	0.043	13736	12527	11570
166	2.745	2.278	0.379	0.044	13607	12532	11596
167	2.724	2.278	0.379	0.047	13924	12552	11637
168	2.61	2.261	0.378	0.047	13932	12532	11608
169	2.574	2.278	0.378	0.047	13874	12512	11598
170	2.459	2.299	0.379	0.045	13806	12520	11609
171	2.316	2.357	0.379	0.044	13893	12513	11582
172	2.324	2.284	0.379	0.046	13811	12457	11521
173	2.505	2.295	0.379	0.047	13674	12343	11344
174	2.538	2.276	0.379	0.044	13558	12285	11296
175	2.342	2.277	0.379	0.045	13693	12386	11405

CLS Single Level Calibration Using Hanst 1.0 cm⁻¹ Reference Spectra (Continued)

File	CH ₄	CO	N ₂ O	SF ₆	H ₂ O(1)	H ₂ O(2)	H ₂ O(3)
176	2.293	2.289	0.379	0.044	13659	12390	11391
177	2.328	2.297	0.378	0.047	13737	12376	11378
178	2.41	2.292	0.378	0.044	13681	12354	11355
179	2.432	2.286	0.379	0.044	13617	12322	11305
180	2.282	2.373	0.380	0.044	13615	12278	11189
181	2.187	2.293	0.379	0.047	13716	12305	11276
182	2.186	2.280	0.379	0.048	13650	12324	11348
183	2.199	2.279	0.378	0.044	13626	12318	11338
184	2.305	2.326	0.379	0.046	13490	12208	11153
185	2.3	2.317	0.380	0.048	13458	12176	11123
186	2.201	2.290	0.379	0.047	13560	12215	11187
187	2.175	2.283	0.379	0.044	13490	12283	11276
188	2.128	2.285	0.378	0.044	13749	12401	11444
189	2.154	2.284	0.378	0.041	13658	12398	11451
190	2.209	2.285	0.377	0.043	13812	12471	11517
191	2.342	2.286	0.378	0.042	13895	12472	11558
192	2.515	2.291	0.378	0.046	14011	12527	11648
193	2.582	2.298	0.377	0.044	14020	12600	11716
194	2.584	2.318	0.377	0.048	14084	12589	11696
195	2.735	2.339	0.378	0.047	14051	12589	11634
196	3.327	2.330	0.377	0.046	14018	12612	11717
197	4.492	2.309	0.377	0.047	14138	12632	11717
198	4.729	2.312	0.378	0.044	13895	12514	11557
199	4.625	2.324	0.379	0.043	13667	12324	11239
200	3.832	2.316	0.380	0.044	13472	12209	11126
201	3.182	2.305	0.381	0.046	13257	12022	10927
202	3.007	2.299	0.381	0.045	13133	11966	10868
203	3.279	2.297	0.382	0.043	13194	12066	11018
204	3.066	2.286	0.382	0.042	13202	12088	11059

CLS Single Level Calibration Using Hanst 1.0 cm⁻¹ Reference Spectra (Continued)

File	CH ₄	CO	N ₂ O	SF ₆	H ₂ O(1)	H ₂ O(2)	H ₂ O(3)
205	2.815	2.293	0.382	0.044	13207	11986	10939
206	2.685	2.298	0.381	0.044	13075	11943	10855
207	2.557	2.304	0.382	0.047	13104	11885	10802
208	2.525	2.307	0.382	0.045	12655	11678	10425
209	2.559	2.313	0.383	0.044	12526	11526	10281
210	2.527	2.317	0.383	0.044	12350	11424	10086
211	2.491	2.322	0.383	0.042	12352	11439	10153
212	2.398	2.310	0.383	0.044	12528	11490	10223
213	2.387	2.309	0.383	0.045	12592	11518	10255
214	2.379	2.312	0.382	0.045	12564	11514	10259
215	2.351	2.344	0.383	0.046	12496	11444	10134
216	2.399	2.319	0.383	0.044	12432	11418	10133
217	2.431	2.320	0.383	0.044	12501	11467	10194
218	2.461	2.319	0.383	0.045	12390	11378	10074
219	2.428	2.320	0.383	0.046	12304	11293	9948
220	2.384	2.358	0.384	0.045	12272	11247	9878
221	2.471	2.410	0.385	0.042	11974	11144	9706
222	2.516	2.372	0.384	0.045	12029	11180	9743
223	2.652	2.371	0.384	0.043	11996	11125	9675
224	2.899	2.412	0.384	0.041	12107	11253	9818
225	2.955	2.396	0.383	0.044	12475	11484	10090
226	3.215	2.431	0.384	0.049	12380	11280	9786
227	3.075	2.427	0.384	0.046	12190	11226	9680
228	2.827	2.412	0.384	0.046	12325	11315	9865
229	3.05	2.406	0.384	0.047	12515	11392	9995
230	2.823	2.389	0.384	0.046	12404	11331	9930
231	2.844	2.365	0.384	0.041	12179	11307	9971
232	3.223	2.381	0.384	0.043	12342	11356	9984
233	3.665	2.386	0.384	0.048	12447	11354	9960

CLS Single Level Calibration Using Hanst 1.0 cm⁻¹ Reference Spectra (Continued)

File	CH ₄	CO	N ₂ O	SF ₆	H ₂ O(1)	H ₂ O(2)	H ₂ O(3)
234	4.641	2.401	0.383	0.045	12732	11577	10251
235	5.518	2.406	0.383	0.045	12850	11675	10364
236	4.718	2.435	0.384	0.046	12375	11294	9780
237	3.958	2.440	0.384	0.045	12400	11348	9784
238	3.846	2.430	0.384	0.046	12412	11401	9823
239	3.627	2.435	0.384	0.046	12554	11409	9877
240	3.536	2.406	0.384	0.047	12425	11355	9796
241	3.573	2.393	0.384	0.047	12432	11382	9762
242	3.316	2.391	0.385	0.046	12247	11209	9666
243	3.153	2.397	0.385	0.042	11903	11049	9535
244	3.121	2.413	0.386	0.044	11726	10863	9264
245	3.147	2.410	0.386	0.044	11829	10930	9336
246	3.075	2.389	0.386	0.045	11795	10890	9345
247	3.104	2.413	0.386	0.046	11840	10935	9389
248	2.969	2.477	0.386	0.045	11770	10879	9306
249	2.834	2.420	0.387	0.045	11682	10780	9232
250	2.75	2.404	0.386	0.046	11503	10704	9127
251	2.717	2.391	0.386	0.047	11593	10685	9113
252	2.876	2.400	0.386	0.044	11612	10739	9194
253	2.979	2.411	0.386	0.044	11666	10788	9256
254	2.612	2.404	0.387	0.044	11631	10807	9275
255	2.357	2.391	0.387	0.048	11806	10850	9366
256	2.434	2.457	0.388	0.046	11671	10790	9253
257	2.482	2.483	0.388	0.046	11484	10670	9055
258	2.539	2.484	0.389	0.045	11448	10602	8956
259	2.557	2.489	0.389	0.042	11269	10541	8853
260	2.598	2.462	0.388	0.045	11205	10417	8691
261	2.599	2.485	0.388	0.044	11188	10496	8785
262	2.59	2.456	0.387	0.047	11527	10632	9024

CLS Single Level Calibration Using Hanst 1.0 cm⁻¹ Reference Spectra (Continued)

File	CH ₄	CO	N ₂ O	SF ₆	H ₂ O(1)	H ₂ O(2)	H ₂ O(3)
263	2.71	2.475	0.388	0.047	11604	10709	9084
264	2.735	2.451	0.387	0.045	11539	10720	9095
265	2.636	2.438	0.387	0.048	11592	10661	9060
266	2.699	2.441	0.387	0.044	11374	10607	8992
267	2.683	2.445	0.389	0.044	11291	10470	8786
268	2.655	2.531	0.389	0.045	11192	10421	8680
269	2.617	2.525	0.390	0.045	11129	10365	8607
270	2.592	2.508	0.389	0.045	11231	10400	8680
271	2.583	2.545	0.390	0.044	11141	10435	8705
272	2.541	2.588	0.390	0.044	11211	10494	8773
273	2.729	3.032	0.396	0.044	11395	10653	8830
274	3.351	2.849	0.394	0.045	11577	10765	9037
275	3.231	2.643	0.392	0.047	11571	10651	8969
276	3.168	2.582	0.391	0.046	11445	10630	8979
277	3.114	2.601	0.391	0.044	11408	10614	8901
278	3.024	2.770	0.393	0.045	11362	10599	8839
279	2.927	2.833	0.394	0.045	11410	10623	8877
280	2.85	2.837	0.394	0.043	11428	10650	8932
281	2.872	2.904	0.395	0.043	11409	10658	8908
282	2.883	2.862	0.394	0.041	11367	10623	8876
283	2.857	2.816	0.393	0.040	11106	10517	8738
284	2.864	2.774	0.393	0.044	11144	10433	8652
285	2.878	3.144	0.399	0.044	11090	10435	8519
286	2.898	3.075	0.398	0.041	11077	10486	8528
287	2.92	3.164	0.399	0.042	11019	10436	8376
288	2.964	3.187	0.399	0.044	11310	10587	8588
289	3.112	3.141	0.398	0.045	11373	10613	8591
290	3.124	3.118	0.398	0.056	10979	10673	8700
291	3.16	3.184	0.399	0.061	10781	10558	8383

CLS Single Level Calibration Using Hanst 1.0 cm⁻¹ Reference Spectra (Continued)

File	CH₄	CO	N₂O	SF₆	H₂O(1)	H₂O(2)	H₂O(3)
292	3.237	3.267	0.400	0.015	10150	10554	8161
293	3.374	3.360	0.402	0.007	9832	10569	8054
294	3.452	3.217	0.399	0.005	9899	10674	8539
295	3.219	2.995	0.396	0.003	10027	10829	8963
296	3.166	3.028	0.396	0.002	10100	10906	9104
297	3.187	2.944	0.395	0.002	10081	10915	9122
298	3.152	2.879	0.394	0.001	10165	10942	9260
299	3.149	2.833	0.393	0.002	10243	11003	9371
300	3.328	2.957	0.395	0.001	10461	11176	9613
301	3.316	2.953	0.395	0.000	10561	11297	9747
302	3.224	2.860	0.394	0.000	10734	11401	9940
303	3.224	2.808	0.398	0.001	10926	11521	10114
304	3.369	2.827	0.403	0.000	11024	11581	10235
305	3.469	2.832	0.404	0.000	11013	11622	10241
306	3.562	2.848	0.407	0.000	11108	11660	10281
Avg	3.006	2.348	0.378	0.041	13614	12394	11329
Std	0.835	0.241	0.010	0.009	1524	1076	1470

Attachment 2

Concentration Data from CLS Single Level Calibration Using Etrans Reference Spectra

CLS Single Level Calibration Using Etrans 1.462 cm⁻¹ Reference Spectra

File	CH ₄	CO	N ₂ O	SF ₆	H ₂ O(1)	H ₂ O(2)	H ₂ O(3)
2	2.385	2.177	0.356	0.049	16341	16428	13537
3	2.271	2.134	0.354	0.048	16598	16565	13726
4	2.196	2.086	0.353	0.045	16610	16639	13848
5	2.182	2.167	0.354	0.044	16944	16763	13961
6	2.234	2.111	0.353	0.042	16808	16727	13973
7	2.275	2.097	0.353	0.041	16997	16729	13954
8	2.344	2.137	0.353	0.042	16889	16740	13917
9	2.508	2.084	0.353	0.046	16892	16801	13992
10	2.571	2.079	0.352	0.042	17113	16781	13971
11	2.637	2.095	0.352	0.041	17063	16748	13926
12	2.555	2.102	0.352	0.040	16839	16770	13959
13	2.431	2.049	0.350	0.044	16961	16892	14132
14	2.388	2.094	0.350	0.045	17081	16918	14111
15	2.376	2.108	0.349	0.044	17178	16933	14106
16	2.353	2.051	0.348	0.043	17110	16930	14161
17	2.340	2.053	0.348	0.046	16956	16940	14202
18	2.340	2.041	0.347	0.044	17114	16999	14248
19	2.316	2.034	0.346	0.042	17247	17016	14324
20	2.379	2.027	0.345	0.044	17224	17083	14315
21	2.374	2.038	0.345	0.047	17172	17119	14338
22	2.269	2.031	0.344	0.043	17200	17070	14290
23	2.211	2.016	0.343	0.046	17176	17166	14366
24	2.267	2.011	0.342	0.045	17344	17207	14435
25	2.235	1.978	0.341	0.041	17599	17254	14511
26	2.108	1.956	0.341	0.043	17502	17211	14389
27	2.080	1.948	0.339	0.041	17329	17123	14313
28	2.072	1.933	0.339	0.042	17238	17107	14317
29	2.195	1.940	0.340	0.035	17405	17123	14340
30	2.151	1.945	0.339	0.044	17260	17135	14352

CLS Single Level Calibration Using Etrans 1.462 cm⁻¹ Reference Spectra (Continued)

File	CH ₄	CO	N ₂ O	SF ₆	H ₂ O(1)	H ₂ O(2)	H ₂ O(3)
31	2.177	1.934	0.340	0.037	17210	16964	14125
32	2.241	1.925	0.339	0.040	17259	17099	14302
33	2.085	1.908	0.338	0.040	17164	17020	14175
34	2.113	1.905	0.338	0.042	16933	16892	14017
35	2.080	1.910	0.340	0.030	17159	16892	13984
36	1.956	1.905	0.341	0.032	16881	16768	13880
37	1.995	1.908	0.339	0.035	16942	16890	14043
38	2.022	1.915	0.339	0.033	17310	17021	14173
39	1.992	1.928	0.339	0.035	17296	17055	14210
40	2.032	1.941	0.339	0.035	17402	17044	14225
41	1.910	1.902	0.340	0.031	17089	16832	13952
42	1.969	1.901	0.340	0.034	17131	16921	14114
43	1.990	1.914	0.338	0.040	17084	16982	14134
44	2.157	1.906	0.338	0.038	17218	17090	14303
45	2.168	1.922	0.339	0.034	17444	17138	14359
46	2.512	1.929	0.337	0.041	17304	17182	14364
47	2.426	1.923	0.337	0.044	16873	17041	14191
48	2.301	1.915	0.337	0.041	16795	16928	14026
49	2.242	1.909	0.339	0.041	16615	16782	13855
50	2.265	1.911	0.337	0.039	17049	16912	14019
51	2.258	1.921	0.339	0.031	17153	16965	14088
52	2.147	1.917	0.338	0.035	17452	17175	14375
53	2.113	1.925	0.338	0.039	17263	17142	14370
54	2.046	1.934	0.338	0.040	17073	17027	14189
55	2.116	1.925	0.338	0.040	17092	17055	14237
56	2.094	1.911	0.337	0.037	17150	17070	14241
57	2.079	1.923	0.337	0.041	17043	17091	14290
58	2.097	1.910	0.337	0.036	17272	17081	14244
59	2.149	1.931	0.337	0.036	17265	17093	14226

CLS Single Level Calibration Using Etrans 1.462 cm⁻¹ Reference Spectra (Continued)

File	CH ₄	CO	N ₂ O	SF ₆	H ₂ O(1)	H ₂ O(2)	H ₂ O(3)
60	2.346	1.926	0.337	0.039	17094	17102	14259
61	2.115	1.930	0.337	0.040	17081	17183	14371
62	2.060	1.918	0.337	0.039	17298	17218	14431
63	2.304	1.925	0.337	0.032	17430	17149	14310
64	2.339	1.946	0.337	0.036	17320	17126	14266
65	2.239	1.912	0.336	0.039	17013	17025	14119
66	2.362	1.918	0.336	0.041	16886	17011	14062
67	2.450	1.922	0.336	0.037	16842	16928	13995
68	2.308	1.944	0.337	0.037	16610	16799	13793
69	2.287	1.921	0.336	0.041	16548	16807	13847
70	2.302	1.913	0.337	0.042	16430	16821	13838
71	2.471	1.921	0.336	0.042	16623	16893	13939
72	2.448	1.923	0.337	0.036	16984	16865	13940
73	2.329	1.915	0.337	0.038	16728	16844	13890
74	2.339	1.910	0.337	0.037	17036	16981	14109
75	2.411	1.913	0.337	0.040	16793	16854	13916
76	2.383	1.916	0.336	0.038	16982	17005	14111
77	2.463	1.941	0.336	0.036	17273	17168	14305
78	2.528	1.914	0.336	0.037	16933	17049	14177
79	2.407	1.922	0.337	0.040	16521	16864	13901
80	2.346	1.969	0.337	0.039	16800	16975	14039
81	2.287	1.925	0.337	0.040	16550	16821	13837
82	2.284	1.932	0.337	0.040	16475	16790	13834
83	2.253	1.923	0.337	0.037	16822	16852	13881
84	2.396	1.920	0.336	0.037	17110	17103	14239
85	2.428	1.917	0.337	0.037	17043	17015	14119
86	2.210	1.921	0.336	0.040	16636	16899	13883
87	2.317	1.917	0.336	0.033	16934	16909	13927
88	2.150	1.918	0.337	0.031	17094	16943	13970

CLS Single Level Calibration Using Etrans 1.462 cm⁻¹ Reference Spectra (Continued)

File	CH ₄	CO	N ₂ O	SF ₆	H ₂ O(1)	H ₂ O(2)	H ₂ O(3)
89	2.092	1.921	0.337	0.030	16954	16969	14033
90	2.242	1.925	0.337	0.038	16735	16843	13835
91	2.474	1.932	0.337	0.037	16695	16853	13834
92	2.550	1.917	0.337	0.039	16722	16888	13912
93	2.635	1.923	0.337	0.038	16799	16911	13974
94	2.925	1.921	0.337	0.040	16954	17018	14078
95	3.113	1.920	0.337	0.040	16761	16959	14018
96	3.286	1.921	0.336	0.040	16960	17030	14100
97	2.972	1.920	0.336	0.042	16703	16971	14049
98	2.583	1.926	0.336	0.042	16640	16932	13994
99	2.667	1.924	0.337	0.039	16905	16994	14061
100	2.792	1.924	0.337	0.039	16859	17000	14091
101	2.708	1.920	0.337	0.041	16756	16952	14019
102	2.640	1.921	0.338	0.041	16769	16937	14036
103	2.694	1.926	0.338	0.042	16607	16887	13929
104	2.757	1.927	0.338	0.039	16691	16907	13968
105	2.868	1.927	0.338	0.040	16753	16908	13977
106	3.214	1.929	0.338	0.040	16666	16986	14053
107	3.908	1.930	0.337	0.039	17039	17107	14211
108	4.209	1.932	0.337	0.038	17197	17207	14248
109	3.987	1.937	0.337	0.038	17273	17183	14279
110	3.732	1.933	0.338	0.038	17200	17175	14297
111	3.645	1.930	0.337	0.041	17044	17170	14289
112	3.569	1.929	0.337	0.042	17060	17164	14293
113	3.663	1.930	0.337	0.040	17175	17218	14347
114	3.678	1.934	0.337	0.037	17363	17225	14369
115	3.737	1.941	0.338	0.042	17343	17259	14364
116	3.777	1.939	0.338	0.039	17363	17295	14436
117	4.019	1.943	0.338	0.040	17492	17410	14516

CLS Single Level Calibration Using Etrans 1.462 cm⁻¹ Reference Spectra (Continued)

File	CH ₄	CO	N ₂ O	SF ₆	H ₂ O(1)	H ₂ O(2)	H ₂ O(3)
118	4.330	1.943	0.339	0.039	17734	17453	14541
119	4.745	1.945	0.339	0.038	17814	17456	14566
120	4.792	1.942	0.339	0.039	17804	17472	14598
121	4.332	1.946	0.339	0.040	17822	17442	14577
122	4.010	1.955	0.339	0.036	17960	17461	14582
123	3.858	1.969	0.339	0.037	17859	17460	14606
124	4.154	1.976	0.339	0.038	17951	17488	14584
125	4.603	1.976	0.340	0.038	18002	17579	14654
126	5.192	1.968	0.339	0.038	18089	17673	14762
127	5.240	1.970	0.340	0.038	18251	17686	14816
128	5.214	1.970	0.340	0.038	18207	17672	14792
129	5.133	1.962	0.340	0.037	18191	17656	14798
130	4.753	1.961	0.340	0.037	18230	17663	14829
131	4.806	1.972	0.341	0.036	18291	17707	14868
132	4.763	1.970	0.341	0.036	18188	17686	14849
133	4.514	1.968	0.341	0.037	18291	17630	14794
134	4.340	1.969	0.34	0.038	18035	17600	14786
135	4.685	1.961	0.340	0.036	18171	17576	14783
136	5.425	1.958	0.340	0.037	18054	17586	14788
137	4.275	1.953	0.341	0.038	17481	17347	14568
138	3.534	1.962	0.34	0.036	17628	17270	14463
139	3.149	1.969	0.341	0.039	17549	17288	14516
140	2.763	1.972	0.343	0.041	17158	17121	14377
141	2.468	1.982	0.344	0.044	16961	17075	14288
142	2.591	1.975	0.344	0.042	16931	16992	14224
143	2.600	1.967	0.344	0.038	17049	16907	14097
144	2.563	1.966	0.344	0.042	16835	16892	14079
145	2.675	1.968	0.345	0.045	16717	16836	13991
146	2.716	1.975	0.346	0.044	16643	16752	13913

CLS Single Level Calibration Using Etrans 1.462 cm⁻¹ Reference Spectra (Continued)

File	CH ₄	CO	N ₂ O	SF ₆	H ₂ O(1)	H ₂ O(2)	H ₂ O(3)
147	2.718	1.987	0.347	0.045	16637	16714	13851
148	2.634	1.975	0.347	0.042	16643	16747	13929
149	2.589	1.976	0.347	0.041	16610	16695	13868
150	2.785	1.973	0.348	0.041	16466	16595	13718
151	2.790	1.972	0.349	0.042	16455	16535	13694
152	2.740	1.967	0.349	0.044	16205	16481	13590
153	2.620	1.967	0.349	0.045	16149	16379	13445
154	2.683	1.987	0.350	0.042	16066	16285	13372
155	2.684	1.977	0.350	0.043	16011	16250	13328
156	2.665	1.973	0.350	0.044	16017	16214	13274
157	2.474	1.981	0.349	0.043	16241	16247	13316
158	2.388	1.982	0.349	0.042	15919	16184	13233
159	2.301	1.985	0.349	0.041	15851	16132	13178
160	2.392	1.993	0.350	0.039	15913	16109	13140
161	2.511	2.007	0.351	0.042	15759	16063	13075
162	2.500	2.014	0.351	0.044	15839	16107	13083
163	2.517	2.056	0.351	0.043	15631	15965	12922
164	2.534	2.087	0.352	0.042	15626	15958	12889
165	2.501	2.020	0.351	0.042	15523	15995	12999
166	2.461	2.004	0.351	0.043	15286	16009	13029
167	2.445	2.005	0.352	0.045	15643	16027	13060
168	2.345	1.992	0.352	0.046	15615	15989	13014
169	2.317	2.004	0.351	0.046	15520	15974	13009
170	2.218	2.022	0.352	0.044	15624	15972	12994
171	2.100	2.068	0.352	0.043	15782	15968	12987
172	2.104	2.009	0.352	0.045	15577	15896	12917
173	2.256	2.015	0.352	0.046	15336	15754	12718
174	2.281	2.000	0.353	0.043	15286	15668	12630
175	2.122	2.001	0.352	0.044	15459	15820	12803

CLS Single Level Calibration Using Etrans 1.462 cm⁻¹ Reference Spectra (Continued)

File	CH ₄	CO	N ₂ O	SF ₆	H ₂ O(1)	H ₂ O(2)	H ₂ O(3)
176	2.081	2.010	0.352	0.043	15490	15823	12788
177	2.109	2.017	0.351	0.046	15371	15806	12772
178	2.181	2.012	0.351	0.043	15443	15787	12745
179	2.195	2.007	0.352	0.043	15368	15739	12672
180	2.071	2.075	0.353	0.043	15317	15681	12568
181	1.990	2.013	0.352	0.046	15357	15705	12626
182	1.988	2.003	0.352	0.047	15243	15728	12701
183	1.998	2.003	0.351	0.043	15394	15722	12679
184	2.084	2.038	0.352	0.044	15198	15575	12455
185	2.082	2.031	0.353	0.046	15022	15534	12431
186	1.997	2.010	0.353	0.046	15163	15587	12494
187	1.977	2.006	0.352	0.043	15142	15668	12601
188	1.939	2.008	0.351	0.043	15531	15828	12809
189	1.962	2.007	0.351	0.040	15626	15829	12810
190	2.010	2.009	0.350	0.042	15637	15931	12903
191	2.121	2.009	0.35	0.041	15775	15937	12952
192	2.267	2.014	0.350	0.045	15827	16000	13041
193	2.324	2.021	0.349	0.043	15872	16092	13122
194	2.326	2.037	0.35	0.047	15835	16075	13104
195	2.450	2.056	0.350	0.045	15859	16059	13008
196	2.945	2.048	0.350	0.045	15816	16093	13089
197	3.918	2.032	0.349	0.046	15927	16121	13066
198	4.114	2.032	0.351	0.043	15755	15966	12889
199	4.029	2.038	0.352	0.042	15490	15726	12556
200	3.362	2.030	0.353	0.043	15191	15576	12430
201	2.819	2.018	0.354	0.045	14801	15347	12225
202	2.671	2.013	0.355	0.043	14707	15274	12138
203	2.899	2.013	0.355	0.042	14863	15398	12292
204	2.724	2.004	0.356	0.041	14966	15431	12361

CLS Single Level Calibration Using Etrans 1.462 cm⁻¹ Reference Spectra (Continued)

File	CH ₄	CO	N ₂ O	SF ₆	H ₂ O(1)	H ₂ O(2)	H ₂ O(3)
205	2.510	2.008	0.356	0.043	14858	15299	12197
206	2.399	2.013	0.355	0.043	14675	15229	12093
207	2.292	2.015	0.356	0.046	14588	15161	12041
208	2.262	2.016	0.357	0.044	14143	14887	11627
209	2.288	2.018	0.358	0.043	13953	14689	11424
210	2.261	2.020	0.358	0.043	13740	14559	11217
211	2.228	2.025	0.358	0.041	13845	14578	11275
212	2.153	2.016	0.358	0.043	13952	14641	11340
213	2.143	2.015	0.358	0.044	13984	14684	11382
214	2.140	2.016	0.357	0.044	13990	14685	11408
215	2.115	2.041	0.358	0.045	13845	14596	11293
216	2.156	2.021	0.358	0.043	13817	14561	11272
217	2.180	2.022	0.358	0.043	13944	14627	11344
218	2.208	2.020	0.358	0.043	13799	14511	11212
219	2.179	2.019	0.358	0.045	13590	14405	11072
220	2.142	2.049	0.359	0.044	13621	14351	10978
221	2.210	2.091	0.360	0.041	13363	14195	10758
222	2.249	2.060	0.36	0.044	13261	14247	10833
223	2.364	2.058	0.359	0.042	13326	14176	10752
224	2.574	2.093	0.359	0.040	13585	14346	10931
225	2.622	2.085	0.358	0.043	13935	14627	11239
226	2.841	2.108	0.359	0.048	13573	14377	10908
227	2.726	2.103	0.359	0.045	13449	14317	10814
228	2.517	2.094	0.358	0.045	13653	14431	11002
229	2.704	2.090	0.358	0.045	13850	14528	11155
230	2.514	2.074	0.358	0.045	13718	14458	11076
231	2.527	2.055	0.359	0.040	13691	14421	11078
232	2.848	2.069	0.359	0.042	13807	14485	11127
233	3.215	2.074	0.359	0.047	13650	14470	11058

CLS Single Level Calibration Using Etrans 1.462 cm⁻¹ Reference Spectra (Continued)

File	CH ₄	CO	N ₂ O	SF ₆	H ₂ O(1)	H ₂ O(2)	H ₂ O(3)
234	4.032	2.089	0.357	0.043	14259	14765	11383
235	4.765	2.095	0.357	0.044	14373	14886	11515
236	4.097	2.113	0.359	0.045	13688	14391	10871
237	3.468	2.116	0.359	0.044	13783	14470	10930
238	3.374	2.110	0.358	0.045	13769	14532	10989
239	3.192	2.114	0.358	0.045	13925	14546	11046
240	3.120	2.089	0.359	0.046	13720	14485	10976
241	3.152	2.079	0.359	0.046	13728	14513	10960
242	2.931	2.075	0.360	0.045	13552	14297	10813
243	2.788	2.077	0.360	0.041	13284	14090	10614
244	2.757	2.087	0.361	0.043	12949	13849	10297
245	2.782	2.086	0.361	0.043	13092	13936	10410
246	2.715	2.069	0.361	0.044	12982	13881	10357
247	2.740	2.089	0.361	0.045	12985	13929	10412
248	2.626	2.139	0.361	0.044	12951	13863	10313
249	2.512	2.092	0.362	0.044	12856	13734	10226
250	2.438	2.079	0.362	0.045	12558	13630	10073
251	2.410	2.069	0.362	0.046	12661	13602	10059
252	2.544	2.076	0.362	0.043	12790	13683	10149
253	2.630	2.086	0.361	0.043	12870	13744	10231
254	2.329	2.079	0.362	0.042	12865	13778	10275
255	2.112	2.070	0.363	0.046	12893	13828	10367
256	2.178	2.122	0.364	0.045	12794	13751	10239
257	2.219	2.141	0.364	0.045	12569	13603	10026
258	2.263	2.140	0.364	0.044	12557	13510	9899
259	2.280	2.143	0.365	0.041	12498	13433	9781
260	2.311	2.121	0.364	0.044	12205	13272	9610
261	2.312	2.140	0.364	0.043	12269	13371	9708
262	2.307	2.119	0.363	0.046	12562	13547	9968

CLS Single Level Calibration Using Etrans 1.462 cm⁻¹ Reference Spectra (Continued)

File	CH ₄	CO	N ₂ O	SF ₆	H ₂ O(1)	H ₂ O(2)	H ₂ O(3)
263	2.408	2.136	0.363	0.046	12634	13636	10045
264	2.428	2.117	0.363	0.044	12641	13653	10058
265	2.341	2.106	0.363	0.047	12588	13570	9989
266	2.397	2.106	0.363	0.043	12487	13514	9949
267	2.384	2.107	0.364	0.043	12391	13346	9730
268	2.360	2.175	0.365	0.044	12243	13283	9606
269	2.329	2.169	0.365	0.044	12164	13216	9527
270	2.307	2.157	0.365	0.044	12283	13254	9605
271	2.302	2.186	0.365	0.043	12212	13306	9634
272	2.268	2.221	0.365	0.043	12323	13385	9730
273	2.429	2.577	0.368	0.042	12594	13592	9846
274	2.946	2.434	0.367	0.044	12772	13717	10019
275	2.842	2.269	0.366	0.046	12649	13568	9906
276	2.790	2.219	0.366	0.045	12538	13541	9915
277	2.745	2.234	0.366	0.043	12566	13528	9841
278	2.668	2.369	0.367	0.044	12464	13507	9770
279	2.589	2.419	0.367	0.044	12529	13544	9826
280	2.530	2.421	0.367	0.042	12664	13586	9912
281	2.546	2.475	0.367	0.042	12605	13598	9877
282	2.554	2.440	0.367	0.040	12676	13561	9847
283	2.531	2.403	0.367	0.039	12417	13419	9687
284	2.537	2.368	0.367	0.043	12220	13311	9598
285	2.554	2.662	0.370	0.043	12159	13326	9484
286	2.574	2.610	0.370	0.040	12273	13376	9514
287	2.592	2.680	0.371	0.041	12147	13304	9342
288	2.634	2.701	0.371	0.043	12453	13503	9624
289	2.759	2.664	0.370	0.044	12517	13533	9629
290	2.769	2.647	0.370	0.055	11491	13614	9759
291	2.804	2.698	0.371	0.060	11015	13464	9460

CLS Single Level Calibration Using Etrans 1.462 cm⁻¹ Reference Spectra (Continued)

File	CH ₄	CO	N ₂ O	SF ₆	H ₂ O(1)	H ₂ O(2)	H ₂ O(3)
292	2.880	2.765	0.372	0.015	12459	13458	9305
293	3.004	2.837	0.372	0.007	12428	13492	9270
294	3.054	2.725	0.370	0.005	12651	13627	9653
295	2.848	2.550	0.368	0.003	12902	13821	10017
296	2.798	2.578	0.368	0.002	13053	13920	10146
297	2.817	2.510	0.367	0.002	13039	13929	10169
298	2.784	2.460	0.367	0.001	13211	13960	10279
299	2.783	2.424	0.366	0.002	13280	14036	10406
300	2.929	2.526	0.367	0.001	13631	14255	10651
301	2.920	2.524	0.366	0.000	13783	14414	10804
302	2.844	2.453	0.366	0.000	14028	14542	11020
303	2.847	2.413	0.37	0.001	14195	14697	11237
304	2.968	2.429	0.375	0.000	14398	14770	11343
305	3.053	2.434	0.376	0.000	14394	14823	11347
306	3.133	2.446	0.378	0.000	14543	14879	11412
avg	2.680	2.058	0.35	0.040	15531	15841	12719
std	0.703	0.182	0.011	0.009	1859	1402	1727

Attachment 3

Concentration Data from CLS Multilevel Calibration Using Etrans Reference Spectra

CLS Multilevel Calibration Using Etrams 1.462 cm⁻¹ Reference Spectra

File	CH ₄	CO	N ₂ O	SF ₆	H ₂ O(1)	H ₂ O(2)	H ₂ O(3)
2	2.364	2.295	0.355	0.047	15684	17435	13145
3	2.247	2.25	0.353	0.046	15897	17636	13343
4	2.172	2.200	0.352	0.043	15881	17743	13474
5	2.158	2.285	0.353	0.042	16189	17925	13597
6	2.209	2.226	0.352	0.040	16048	17873	13606
7	2.252	2.211	0.352	0.039	16226	17876	13590
8	2.321	2.253	0.353	0.040	16141	17892	13558
9	2.489	2.198	0.352	0.044	16247	17982	13634
10	2.554	2.193	0.351	0.040	16365	17953	13601
11	2.621	2.210	0.350	0.039	16341	17905	13566
12	2.537	2.216	0.349	0.038	16208	17936	13589
13	2.411	2.162	0.349	0.042	16344	18116	13782
14	2.367	2.209	0.349	0.043	16463	18155	13768
15	2.355	2.223	0.349	0.042	16534	18177	13761
16	2.332	2.163	0.347	0.041	16505	18173	13822
17	2.318	2.165	0.347	0.044	16423	18188	13864
18	2.319	2.153	0.346	0.042	16568	18275	13914
19	2.294	2.145	0.345	0.040	16659	18300	13991
20	2.358	2.138	0.344	0.042	16714	18403	13986
21	2.353	2.150	0.344	0.044	16709	18512	14006
22	2.246	2.142	0.343	0.041	16705	18379	13960
23	2.188	2.127	0.342	0.043	16792	18660	14041
24	2.244	2.122	0.341	0.043	16971	18789	14110
25	2.212	2.103	0.341	0.039	17142	18936	14190
26	2.085	2.064	0.339	0.040	17046	18799	14062
27	2.056	2.055	0.338	0.039	16924	18528	13982
28	2.048	2.040	0.338	0.039	16868	18480	13987
29	2.171	2.047	0.339	0.033	16921	18528	14013
30	2.126	2.052	0.337	0.042	16964	18565	14025

CLS Multilevel Calibration Using Etrans 1.462 cm⁻¹ Reference Spectra (Continued)

File	CH ₄	CO	N ₂ O	SF ₆	H ₂ O(1)	H ₂ O(2)	H ₂ O(3)
31	2.153	2.040	0.338	0.035	16804	18224	13781
32	2.218	2.031	0.337	0.038	16839	18453	13975
33	2.061	1.995	0.337	0.038	16796	18306	13839
34	2.089	1.991	0.337	0.039	16654	18118	13663
35	2.056	1.997	0.338	0.028	16662	18118	13629
36	1.931	1.991	0.339	0.030	16480	17936	13516
37	1.970	1.995	0.338	0.033	16547	18114	13694
38	1.998	2.021	0.338	0.030	16869	18308	13838
39	1.967	2.034	0.338	0.032	16848	18359	13881
40	2.008	2.048	0.338	0.032	16891	18342	13896
41	1.885	1.987	0.338	0.029	16563	18029	13596
42	1.944	1.986	0.338	0.032	16647	18160	13775
43	1.965	2.019	0.337	0.038	16746	18250	13801
44	2.133	1.992	0.337	0.036	16831	18427	13980
45	2.145	2.028	0.337	0.032	17001	18577	14041
46	2.494	2.036	0.336	0.039	17036	18713	14042
47	2.406	2.028	0.336	0.042	16768	18339	13857
48	2.279	2.020	0.336	0.039	16605	18170	13671
49	2.218	1.996	0.337	0.039	16412	17956	13493
50	2.242	1.998	0.336	0.037	16767	18148	13666
51	2.235	2.027	0.337	0.029	16720	18226	13748
52	2.123	2.023	0.337	0.033	17052	18691	14056
53	2.089	2.031	0.336	0.037	16939	18589	14053
54	2.022	2.040	0.337	0.038	16773	18318	13861
55	2.092	2.031	0.336	0.038	16825	18360	13912
56	2.070	1.998	0.336	0.035	16856	18383	13924
57	2.054	2.029	0.335	0.039	16792	18433	13989
58	2.073	1.997	0.335	0.034	16927	18403	13937
59	2.125	2.037	0.336	0.034	16916	18441	13914

CLS Multilevel Calibration Using Etrams 1.462 cm⁻¹ Reference Spectra (Continued)

File	CH ₄	CO	N ₂ O	SF ₆	H ₂ O(1)	H ₂ O(2)	H ₂ O(3)
60	2.323	2.032	0.335	0.037	16882	18469	13956
61	2.089	2.036	0.335	0.038	16820	18719	14088
62	2.035	2.041	0.337	0.037	17012	18829	14134
63	2.282	2.031	0.335	0.030	17079	18611	13994
64	2.317	2.053	0.335	0.034	17082	18540	13945
65	2.216	2.000	0.334	0.037	16900	18315	13784
66	2.340	2.023	0.334	0.039	16795	18295	13721
67	2.431	2.028	0.335	0.034	16680	18172	13647
68	2.285	2.050	0.335	0.035	16469	17983	13438
69	2.264	2.027	0.334	0.039	16528	17996	13493
70	2.279	2.018	0.335	0.040	16444	18015	13483
71	2.451	2.027	0.335	0.040	16634	18120	13585
72	2.428	2.029	0.335	0.033	16710	18080	13590
73	2.306	2.020	0.335	0.036	16555	18048	13538
74	2.317	1.997	0.335	0.035	16868	18251	13773
75	2.390	2.000	0.335	0.037	16742	18063	13564
76	2.362	2.021	0.335	0.036	16857	18286	13777
77	2.444	2.047	0.335	0.033	17034	18672	13985
78	2.510	2.020	0.335	0.035	16820	18351	13848
79	2.386	2.028	0.335	0.038	16523	18079	13547
80	2.324	2.077	0.336	0.037	16733	18242	13696
81	2.263	2.031	0.335	0.038	16508	18014	13480
82	2.260	2.038	0.335	0.038	16473	17969	13478
83	2.229	2.028	0.335	0.035	16719	18061	13531
84	2.376	2.026	0.335	0.035	16988	18469	13923
85	2.408	2.022	0.335	0.035	16905	18301	13786
86	2.186	2.027	0.335	0.038	16654	18129	13535
87	2.294	2.023	0.335	0.031	16801	18144	13581
88	2.126	2.023	0.335	0.029	16850	18196	13630

CLS Multilevel Calibration Using Etrams 1.462 cm⁻¹ Reference Spectra (Continued)

File	CH ₄	CO	N ₂ O	SF ₆	H ₂ O(1)	H ₂ O(2)	H ₂ O(3)
89	2.068	2.026	0.335	0.028	16754	18232	13697
90	2.219	2.031	0.335	0.036	16662	18046	13476
91	2.454	2.038	0.336	0.035	16624	18062	13477
92	2.532	2.022	0.336	0.037	16719	18113	13553
93	2.620	2.028	0.335	0.036	16740	18146	13632
94	2.920	2.027	0.335	0.038	17026	18306	13745
95	3.115	2.025	0.336	0.038	16736	18218	13683
96	3.294	2.027	0.335	0.038	16882	18322	13773
97	2.968	2.026	0.335	0.040	16785	18235	13720
98	2.566	2.032	0.335	0.040	16748	18179	13646
99	2.653	2.030	0.336	0.037	16931	18269	13736
100	2.783	2.030	0.336	0.037	16830	18279	13764
101	2.696	2.025	0.335	0.039	16774	18208	13687
102	2.624	2.026	0.336	0.039	16813	18186	13703
103	2.680	2.032	0.336	0.040	16687	18111	13584
104	2.746	2.033	0.336	0.037	16665	18141	13629
105	2.861	2.033	0.336	0.038	16770	18142	13635
106	3.219	2.035	0.336	0.038	16679	18258	13719
107	3.945	2.037	0.336	0.037	16996	18482	13873
108	4.260	2.055	0.337	0.036	17141	18792	13915
109	4.028	2.043	0.336	0.036	17163	18718	13949
110	3.761	2.039	0.336	0.036	17108	18692	13968
111	3.669	2.036	0.336	0.038	17035	18677	13962
112	3.589	2.035	0.336	0.039	17090	18658	13967
113	3.689	2.053	0.337	0.038	17143	18826	14023
114	3.703	2.057	0.337	0.035	17243	18848	14050
115	3.766	2.064	0.338	0.040	17338	18956	14037
116	3.808	2.062	0.338	0.036	17245	19069	14113
117	4.061	2.067	0.338	0.038	17400	19269	14202

CLS Multilevel Calibration Using Etrams 1.462 cm⁻¹ Reference Spectra (Continued)

File	CH ₄	CO	N ₂ O	SF ₆	H ₂ O(1)	H ₂ O(2)	H ₂ O(3)
118	4.386	2.067	0.338	0.037	17563	19335	14222
119	4.824	2.069	0.338	0.035	17648	19339	14248
120	4.874	2.067	0.339	0.036	17661	19364	14280
121	4.388	2.070	0.338	0.037	17635	19318	14260
122	4.052	2.080	0.339	0.034	17749	19347	14270
123	3.892	2.094	0.339	0.034	17627	19346	14299
124	4.202	2.102	0.339	0.036	17658	19389	14281
125	4.674	2.102	0.339	0.036	17758	19530	14351
126	5.284	2.093	0.339	0.036	17772	19677	14463
127	5.333	2.096	0.340	0.035	18045	19696	14517
128	5.307	2.096	0.340	0.035	17935	19675	14489
129	5.225	2.088	0.340	0.035	17868	19650	14493
130	4.833	2.087	0.340	0.034	17877	19662	14530
131	4.889	2.098	0.340	0.034	17982	19730	14567
132	4.842	2.096	0.341	0.033	17906	19697	14545
133	4.581	2.094	0.341	0.034	17956	19609	14489
134	4.397	2.094	0.340	0.036	17758	19562	14478
135	4.761	2.086	0.340	0.033	17843	19526	14478
136	5.522	2.083	0.340	0.034	17778	19541	14475
137	4.329	2.078	0.340	0.036	17174	19170	14251
138	3.552	2.087	0.340	0.034	17287	18991	14144
139	3.151	2.094	0.341	0.037	17303	19048	14215
140	2.753	2.080	0.342	0.039	16889	18525	14072
141	2.448	2.091	0.343	0.041	16778	18390	13968
142	2.574	2.084	0.343	0.039	16676	18267	13908
143	2.584	2.075	0.343	0.036	16637	18141	13763
144	2.546	2.074	0.343	0.040	16551	18118	13739
145	2.661	2.076	0.344	0.043	16555	18036	13647
146	2.703	2.083	0.345	0.042	16444	17912	13566

CLS Multilevel Calibration Using Etrams 1.462 cm⁻¹ Reference Spectra (Continued)

File	CH ₄	CO	N ₂ O	SF ₆	H ₂ O(1)	H ₂ O(2)	H ₂ O(3)
147	2.705	2.096	0.346	0.043	16417	17857	13498
148	2.618	2.083	0.346	0.040	16377	17905	13583
149	2.571	2.084	0.346	0.039	16260	17829	13507
150	2.774	2.081	0.348	0.039	16152	17683	13362
151	2.779	2.080	0.348	0.040	16142	17596	13335
152	2.728	2.075	0.348	0.042	15929	17517	13226
153	2.604	2.075	0.348	0.043	15819	17365	13075
154	2.668	2.096	0.349	0.040	15755	17228	12995
155	2.670	2.085	0.349	0.041	15694	17177	12950
156	2.650	2.081	0.349	0.042	15678	17124	12895
157	2.454	2.089	0.348	0.041	15857	17173	12924
158	2.366	2.090	0.348	0.040	15583	17079	12839
159	2.278	2.093	0.349	0.039	15484	17004	12783
160	2.371	2.101	0.349	0.037	15480	16970	12744
161	2.492	2.116	0.350	0.040	15360	16903	12673
162	2.481	2.124	0.349	0.042	15493	16967	12684
163	2.498	2.168	0.348	0.041	15224	16761	12519
164	2.515	2.200	0.349	0.040	15199	16750	12481
165	2.482	2.130	0.349	0.040	15067	16804	12594
166	2.441	2.113	0.349	0.041	14864	16825	12626
167	2.424	2.114	0.350	0.043	15255	16850	12653
168	2.323	2.100	0.349	0.044	15219	16796	12607
169	2.295	2.113	0.349	0.044	15076	16773	12605
170	2.194	2.132	0.349	0.042	15211	16770	12587
171	2.075	2.180	0.349	0.041	15348	16765	12581
172	2.080	2.118	0.349	0.043	15169	16661	12509
173	2.232	2.125	0.350	0.044	14929	16315	12303
174	2.258	2.092	0.350	0.041	14820	16072	12208
175	2.097	2.110	0.350	0.042	15067	16504	12391

CLS Multilevel Calibration Using Etrans 1.462 cm⁻¹ Reference Spectra (Continued)

File	CH ₄	CO	N ₂ O	SF ₆	H ₂ O(1)	H ₂ O(2)	H ₂ O(3)
176	2.056	2.120	0.349	0.041	15063	16515	12377
177	2.084	2.127	0.349	0.044	14954	16465	12358
178	2.156	2.121	0.350	0.041	14992	16411	12332
179	2.171	2.100	0.350	0.041	14904	16273	12255
180	2.046	2.171	0.350	0.041	14855	16109	12150
181	1.964	2.106	0.350	0.044	14908	16177	12210
182	1.962	2.096	0.350	0.045	14793	16243	12280
183	1.973	2.095	0.349	0.041	14897	16226	12262
184	2.059	2.133	0.349	0.043	14738	15862	12031
185	2.056	2.125	0.350	0.044	14561	15805	12000
186	1.972	2.102	0.349	0.044	14699	15877	12066
187	1.951	2.098	0.349	0.041	14671	16072	12179
188	1.913	2.117	0.349	0.041	15052	16527	12396
189	1.937	2.116	0.349	0.038	15075	16529	12393
190	1.985	2.118	0.349	0.040	15188	16712	12494
191	2.097	2.118	0.350	0.039	15212	16720	12541
192	2.243	2.124	0.349	0.043	15322	16812	12630
193	2.301	2.131	0.349	0.041	15391	16945	12713
194	2.303	2.148	0.349	0.045	15368	16920	12692
195	2.429	2.168	0.349	0.043	15336	16895	12592
196	2.940	2.160	0.349	0.043	15308	16946	12684
197	3.955	2.143	0.349	0.044	15450	16987	12644
198	4.159	2.143	0.348	0.041	15236	16762	12454
199	4.071	2.133	0.349	0.040	14940	16237	12113
200	3.372	2.124	0.350	0.041	14671	15862	12001
201	2.810	2.111	0.352	0.043	14306	15547	11793
202	2.657	2.106	0.353	0.042	14182	15446	11706
203	2.892	2.106	0.353	0.041	14210	15617	11861
204	2.711	2.096	0.354	0.039	14409	15662	11935

CLS Multilevel Calibration Using Etrans 1.462 cm⁻¹ Reference Spectra (Continued)

File	CH ₄	CO	N ₂ O	SF ₆	H ₂ O(1)	H ₂ O(2)	H ₂ O(3)
205	2.491	2.101	0.354	0.042	14295	15481	11752
206	2.377	2.106	0.353	0.041	14069	15385	11648
207	2.269	2.109	0.354	0.044	14063	15292	11590
208	2.238	2.109	0.355	0.042	13633	14918	11158
209	2.265	2.112	0.356	0.042	13382	14643	10949
210	2.237	2.114	0.356	0.042	13213	14465	10739
211	2.204	2.118	0.356	0.040	13227	14491	10798
212	2.129	2.109	0.356	0.042	13334	14577	10861
213	2.118	2.108	0.355	0.043	13429	14637	10906
214	2.115	2.109	0.355	0.042	13404	14638	10934
215	2.090	2.136	0.356	0.043	13330	14516	10818
216	2.132	2.115	0.356	0.042	13253	14468	10794
217	2.156	2.116	0.356	0.041	13367	14558	10871
218	2.183	2.114	0.356	0.042	13215	14398	10733
219	2.155	2.112	0.356	0.044	13106	14254	10591
220	2.118	2.143	0.357	0.042	13088	14181	10497
221	2.185	2.188	0.358	0.040	12785	13845	10272
222	2.226	2.155	0.357	0.042	12681	13986	10346
223	2.342	2.154	0.357	0.040	12802	13797	10264
224	2.557	2.190	0.357	0.039	12942	14173	10445
225	2.606	2.182	0.356	0.042	13357	14558	10773
226	2.832	2.206	0.357	0.046	13095	14215	10435
227	2.713	2.201	0.357	0.044	12971	14134	10344
228	2.498	2.191	0.356	0.043	13130	14289	10521
229	2.691	2.187	0.356	0.044	13248	14421	10687
230	2.495	2.171	0.356	0.043	13082	14326	10592
231	2.508	2.151	0.357	0.038	13057	14275	10591
232	2.839	2.165	0.357	0.040	13177	14363	10657
233	3.220	2.170	0.356	0.046	12987	14342	10583

CLS Multilevel Calibration Using Etrams 1.462 cm⁻¹ Reference Spectra (Continued)

File	CH ₄	CO	N ₂ O	SF ₆	H ₂ O(1)	H ₂ O(2)	H ₂ O(3)
234	4.074	2.185	0.355	0.042	13493	14748	10896
235	4.844	2.192	0.355	0.042	13626	14915	11025
236	4.142	2.211	0.357	0.043	13038	14234	10375
237	3.482	2.214	0.356	0.042	13073	14343	10457
238	3.384	2.208	0.356	0.043	13180	14427	10520
239	3.196	2.212	0.356	0.043	13253	14447	10576
240	3.121	2.186	0.356	0.044	13129	14363	10510
241	3.154	2.175	0.357	0.044	13103	14401	10497
242	2.924	2.171	0.358	0.043	12882	14107	10341
243	2.778	2.156	0.357	0.040	12667	13571	10138
244	2.745	2.167	0.358	0.041	12294	13181	9827
245	2.771	2.165	0.358	0.042	12419	13292	9936
246	2.703	2.148	0.358	0.043	12399	13221	9878
247	2.728	2.169	0.358	0.044	12342	13283	9930
248	2.610	2.221	0.358	0.043	12387	13198	9839
249	2.493	2.172	0.359	0.042	12162	13033	9742
250	2.418	2.158	0.359	0.044	11968	12900	9593
251	2.389	2.148	0.359	0.044	11912	12865	9580
252	2.526	2.155	0.359	0.042	12021	12968	9664
253	2.615	2.165	0.358	0.042	12223	13046	9754
254	2.307	2.158	0.359	0.041	12178	13090	9789
255	2.087	2.149	0.360	0.045	12246	13154	9876
256	2.154	2.203	0.361	0.043	12229	13055	9755
257	2.195	2.223	0.361	0.043	11977	12866	9551
258	2.240	2.223	0.361	0.043	11817	12749	9429
259	2.257	2.226	0.361	0.039	11784	12651	9316
260	2.289	2.202	0.361	0.043	11553	12446	9154
261	2.289	2.222	0.361	0.042	11639	12573	9246
262	2.284	2.200	0.360	0.045	11899	12795	9495

CLS Multilevel Calibration Using Etrams 1.462 cm⁻¹ Reference Spectra (Continued)

File	CH₄	CO	N₂O	SF₆	H₂O(1)	H₂O(2)	H₂O(3)
263	2.387	2.218	0.360	0.045	11959	12908	9568
264	2.408	2.198	0.360	0.043	12038	12929	9582
265	2.319	2.187	0.360	0.046	11871	12824	9513
266	2.376	2.187	0.360	0.042	11809	12753	9476
267	2.363	2.188	0.361	0.042	11673	12540	9267
268	2.338	2.259	0.362	0.043	11586	12460	9152
269	2.307	2.253	0.362	0.042	11563	12374	9074
270	2.284	2.240	0.362	0.043	11592	12423	9150
271	2.279	2.270	0.362	0.041	11629	12491	9179
272	2.245	2.307	0.362	0.041	11632	12590	9267
273	2.408	2.680	0.364	0.041	11889	12853	9386
274	2.941	2.531	0.364	0.042	12113	13012	9558
275	2.834	2.357	0.363	0.044	11887	12822	9444
276	2.780	2.305	0.363	0.043	11873	12788	9451
277	2.733	2.320	0.362	0.042	11846	12771	9386
278	2.654	2.463	0.363	0.043	11713	12744	9318
279	2.572	2.514	0.364	0.042	11838	12791	9361
280	2.511	2.517	0.364	0.040	12011	12846	9444
281	2.528	2.573	0.364	0.041	11894	12860	9410
282	2.536	2.537	0.363	0.039	11833	12814	9381
283	2.513	2.498	0.364	0.037	11665	12633	9228
284	2.519	2.462	0.364	0.042	11511	12497	9142
285	2.535	2.769	0.367	0.042	11447	12518	9037
286	2.556	2.715	0.366	0.039	11597	12580	9070
287	2.574	2.789	0.367	0.040	11457	12489	8921
288	2.617	2.810	0.367	0.042	11696	12741	9190
289	2.746	2.772	0.367	0.042	11756	12778	9200
290	2.757	2.754	0.366	0.054	11023	12881	9322
291	2.792	2.808	0.367	0.059	10623	12692	9046

CLS Multilevel Calibration Using Etrans 1.462 cm⁻¹ Reference Spectra (Continued)

File	CH₄	CO	N₂O	SF₆	H₂O(1)	H₂O(2)	H₂O(3)
292	2.870	2.877	0.368	0.013	11605	12684	8907
293	2.997	2.953	0.368	0.006	11629	12727	8881
294	3.051	2.835	0.367	0.003	11797	12898	9226
295	2.838	2.652	0.365	0.002	12090	13146	9564
296	2.788	2.681	0.365	0.001	12221	13272	9685
297	2.807	2.610	0.364	0.000	12257	13284	9709
298	2.773	2.557	0.363	0.000	12322	13324	9808
299	2.772	2.520	0.363	0.000	12475	13430	9926
300	2.923	2.626	0.363	0.000	12707	14006	10171
301	2.914	2.624	0.363	0.000	12872	14265	10323
302	2.836	2.567	0.363	0.000	13065	14439	10543
303	2.839	2.526	0.368	0.000	13233	14653	10766
304	2.963	2.543	0.372	0.000	13306	14754	10874
305	3.052	2.547	0.374	0.000	13420	14827	10877
306	3.134	2.561	0.376	0.000	13500	14904	10943
Avg	2.671	2.161	0.348	0.038	15095	16492	12328
Std	0.729	0.181	0.010	0.009	2035	2270	1784

Attachment 4

Concentration Data from Innovative Nonlinear Algorithm

Concentration Values Reported from Innovative Nonlinear Algorithm

File	CH ₄	CO	N ₂ O	SF ₆	H ₂ O	CO ₂	shift	res
2	2.527	2.401	0.397	0.051	10684	520.1	0.52	1.486
3	2.404	2.344	0.396	0.050	10724	515.3	0.51	1.481
4	2.323	2.285	0.398	0.047	10902	510.9	0.51	1.487
5	2.306	2.399	0.399	0.046	10969	510.9	0.51	1.485
6	2.348	2.316	0.398	0.044	10894	509.1	0.51	1.483
7	2.393	2.295	0.397	0.043	10879	509.1	0.51	1.482
8	2.448	2.339	0.393	0.044	10684	509.7	0.51	1.475
9	2.612	2.269	0.393	0.047	10719	510.5	0.51	1.473
10	2.685	2.255	0.390	0.043	10546	510.0	0.52	1.466
11	2.746	2.268	0.388	0.043	10467	509.2	0.52	1.463
12	2.661	2.274	0.388	0.042	10464	509.5	0.52	1.462
13	2.520	2.202	0.387	0.046	10566	509.5	0.52	1.461
14	2.470	2.261	0.387	0.047	10552	509.9	0.52	1.460
15	2.451	2.278	0.385	0.046	10534	510.1	0.52	1.459
16	2.440	2.209	0.386	0.045	10527	510.0	0.51	1.459
17	2.417	2.212	0.384	0.048	10516	510.4	0.51	1.459
18	2.412	2.193	0.383	0.045	10525	510.4	0.51	1.458
19	2.383	2.186	0.383	0.044	10516	510.4	0.51	1.458
20	2.444	2.176	0.382	0.046	10546	510.0	0.51	1.458
21	2.431	2.188	0.382	0.048	10525	510.7	0.51	1.457
22	2.327	2.184	0.382	0.045	10490	510.0	0.51	1.457
23	2.258	2.160	0.381	0.047	10521	515.5	0.52	1.456
24	2.313	2.158	0.379	0.047	10535	529.3	0.52	1.455
25	2.276	2.112	0.379	0.043	10547	511.4	0.52	1.456
26	2.149	2.087	0.380	0.044	10485	501.1	0.52	1.455
27	2.108	2.071	0.379	0.043	10352	500.4	0.52	1.453
28	2.103	2.050	0.378	0.043	10347	499.0	0.52	1.454
29	2.215	2.062	0.378	0.036	10349	505.3	0.52	1.455
30	2.161	2.064	0.378	0.045	10297	498.2	0.51	1.453

Concentration Values Reported from Innovative Nonlinear Algorithm (Continued)

File	CH₄	CO	N₂O	SF₆	H₂O	CO₂	shift	res
31	2.199	2.050	0.378	0.039	10178	495.2	0.51	1.455
32	2.256	2.040	0.377	0.041	10256	495.9	0.51	1.454
33	2.096	2.024	0.379	0.041	10140	494.6	0.51	1.453
34	2.118	2.013	0.377	0.043	10032	494.2	0.51	1.453
35	2.097	2.024	0.378	0.031	10069	494.1	0.51	1.454
36	1.974	2.013	0.378	0.033	9997	494.1	0.52	1.453
37	2.010	2.014	0.377	0.037	10087	494.5	0.52	1.453
38	2.036	2.028	0.377	0.034	10191	497.4	0.51	1.453
39	2.003	2.039	0.377	0.036	10206	495.4	0.52	1.453
40	2.049	2.056	0.377	0.036	10194	491.1	0.51	1.453
41	1.923	2.012	0.377	0.032	10040	492.3	0.51	1.453
42	1.982	2.010	0.377	0.035	10100	490.9	0.51	1.454
43	1.996	2.027	0.376	0.041	10130	493.3	0.51	1.455
44	2.168	2.027	0.378	0.039	10214	492.9	0.51	1.454
45	2.181	2.046	0.378	0.035	10291	494.1	0.51	1.455
46	2.510	2.054	0.377	0.043	10246	497.4	0.51	1.454
47	2.418	2.049	0.377	0.045	10076	493.6	0.51	1.453
48	2.292	2.031	0.376	0.042	9955	493.2	0.51	1.453
49	2.233	2.023	0.377	0.042	9851	492.2	0.51	1.452
50	2.254	2.021	0.376	0.041	9958	492.4	0.51	1.451
51	2.259	2.032	0.376	0.033	10073	491.3	0.51	1.451
52	2.152	2.033	0.377	0.036	10263	491.2	0.51	1.451
53	2.105	2.035	0.376	0.041	10226	491.0	0.51	1.451
54	2.051	2.049	0.376	0.041	10107	490.7	0.51	1.450
55	2.114	2.042	0.376	0.041	10127	490.3	0.51	1.450
56	2.086	2.026	0.376	0.038	10103	492.7	0.51	1.451
57	2.043	2.041	0.376	0.043	10114	494.1	0.51	1.451
58	2.062	2.030	0.376	0.037	10066	495.6	0.51	1.449
59	2.121	2.053	0.376	0.037	10071	496.1	0.51	1.449

Concentration Values Reported from Innovative Nonlinear Algorithm (Continued)

File	CH₄	CO	N₂O	SF₆	H₂O	CO₂	shift	res
60	2.289	2.038	0.375	0.040	10082	494.7	0.51	1.449
61	2.051	2.054	0.376	0.041	10150	492.4	0.51	1.449
62	2.022	2.038	0.376	0.040	10207	491.5	0.51	1.450
63	2.277	2.041	0.376	0.034	10113	491.2	0.51	1.449
64	2.301	2.065	0.376	0.038	10033	491.5	0.51	1.449
65	2.207	2.025	0.375	0.041	9912	491.3	0.51	1.448
66	2.314	2.022	0.374	0.043	9864	491.8	0.51	1.446
67	2.406	2.035	0.375	0.038	9780	492.9	0.51	1.446
68	2.264	2.057	0.374	0.039	9668	494.8	0.51	1.445
69	2.240	2.030	0.374	0.043	9665	492.5	0.51	1.447
70	2.263	2.020	0.374	0.043	9682	491.7	0.51	1.447
71	2.426	2.032	0.374	0.043	9749	492.2	0.51	1.447
72	2.400	2.036	0.374	0.037	9751	491.8	0.51	1.448
73	2.283	2.023	0.375	0.039	9729	491.4	0.51	1.449
74	2.295	2.015	0.375	0.038	9861	491.5	0.51	1.449
75	2.370	2.021	0.375	0.041	9754	490.8	0.51	1.449
76	2.345	2.026	0.374	0.040	9888	491.2	0.51	1.448
77	2.426	2.061	0.375	0.037	10034	491.3	0.51	1.448
78	2.485	2.020	0.374	0.038	9895	491.4	0.51	1.446
79	2.368	2.029	0.373	0.041	9734	491.3	0.51	1.446
80	2.306	2.089	0.374	0.041	9813	491.2	0.51	1.446
81	2.245	2.034	0.374	0.041	9683	491.7	0.51	1.447
82	2.243	2.046	0.374	0.042	9652	492.2	0.51	1.449
83	2.214	2.033	0.374	0.038	9725	491.4	0.51	1.449
84	2.350	2.033	0.375	0.038	9929	491.7	0.51	1.448
85	2.377	2.026	0.374	0.039	9817	491.8	0.51	1.448
86	2.158	2.034	0.374	0.041	9668	492.0	0.51	1.447
87	2.263	2.024	0.374	0.034	9700	491.7	0.51	1.447
88	2.109	2.029	0.374	0.032	9782	491.9	0.51	1.449

Concentration Values Reported from Innovative Nonlinear Algorithm (Continued)

File	CH₄	CO	N₂O	SF₆	H₂O	CO₂	shift	res
89	2.044	2.027	0.375	0.031	9808	491.7	0.51	1.448
90	2.200	2.036	0.374	0.039	9683	491.9	0.51	1.449
91	2.428	2.043	0.374	0.038	9698	493.5	0.51	1.449
92	2.500	2.024	0.374	0.041	9749	493.7	0.51	1.448
93	2.590	2.032	0.374	0.040	9768	491.9	0.51	1.448
94	2.879	2.018	0.373	0.042	9874	493.0	0.51	1.447
95	3.074	2.026	0.374	0.041	9834	492.9	0.51	1.449
96	3.243	2.032	0.374	0.041	9890	493.2	0.51	1.449
97	2.924	2.025	0.374	0.043	9831	492.3	0.51	1.448
98	2.534	2.034	0.373	0.044	9773	491.5	0.51	1.448
99	2.621	2.042	0.376	0.041	9848	491.4	0.51	1.449
100	2.751	2.036	0.375	0.041	9864	491.7	0.51	1.450
101	2.656	2.031	0.375	0.043	9809	492.2	0.51	1.449
102	2.594	2.026	0.375	0.043	9816	491.6	0.51	1.449
103	2.650	2.029	0.374	0.044	9768	491.4	0.51	1.448
104	2.705	2.030	0.374	0.041	9779	491.5	0.51	1.447
105	2.814	2.033	0.374	0.042	9781	491.7	0.51	1.447
106	3.169	2.033	0.374	0.042	9856	492.7	0.51	1.447
107	3.879	2.040	0.374	0.040	9974	495.0	0.51	1.448
108	4.201	2.048	0.375	0.040	10073	496.4	0.51	1.449
109	3.975	2.049	0.375	0.040	10058	496.1	0.51	1.450
110	3.718	2.049	0.376	0.040	10066	495.5	0.51	1.450
111	3.624	2.046	0.375	0.042	10079	494.8	0.51	1.450
112	3.550	2.044	0.374	0.043	10081	494.3	0.51	1.451
113	3.643	2.045	0.375	0.041	10126	494.8	0.51	1.450
114	3.660	2.052	0.376	0.039	10154	494.5	0.51	1.451
115	3.731	2.060	0.376	0.044	10195	495.2	0.51	1.451
116	3.780	2.058	0.377	0.040	10249	496.5	0.52	1.452
117	4.032	2.065	0.377	0.042	10354	498.4	0.51	1.451

Concentration Values Reported from Innovative Nonlinear Algorithm (Continued)

File	CH₄	CO	N₂O	SF₆	H₂O	CO₂	shift	res
118	4.357	2.065	0.377	0.041	10410	499.6	0.51	1.451
119	4.803	2.068	0.378	0.039	10431	500.4	0.52	1.452
120	4.868	2.068	0.378	0.040	10456	500.7	0.52	1.452
121	4.382	2.070	0.377	0.041	10437	500.3	0.52	1.452
122	4.041	2.086	0.377	0.038	10475	501.6	0.51	1.453
123	3.875	2.104	0.378	0.038	10467	502.5	0.51	1.453
124	4.182	2.111	0.378	0.040	10507	504.6	0.51	1.453
125	4.663	2.107	0.377	0.040	10615	504.7	0.51	1.453
126	5.318	2.105	0.379	0.040	10714	504.7	0.51	1.454
127	5.381	2.106	0.379	0.039	10737	504.2	0.51	1.454
128	5.358	2.109	0.380	0.039	10732	504.3	0.51	1.454
129	5.273	2.099	0.380	0.039	10737	504.5	0.52	1.454
130	4.871	2.097	0.379	0.038	10751	503.3	0.51	1.454
131	4.937	2.107	0.380	0.038	10799	503.7	0.52	1.454
132	4.882	2.102	0.379	0.037	10792	503.8	0.52	1.454
133	4.632	2.103	0.379	0.038	10759	503.8	0.52	1.455
134	4.437	2.104	0.379	0.040	10722	503.5	0.52	1.455
135	4.813	2.092	0.379	0.037	10723	503.9	0.51	1.455
136	5.625	2.089	0.379	0.038	10747	504.1	0.51	1.456
137	4.341	2.082	0.378	0.040	10527	499.1	0.51	1.457
138	3.573	2.089	0.377	0.037	10420	495.6	0.51	1.456
139	3.181	2.097	0.378	0.041	10452	493.9	0.51	1.456
140	2.792	2.096	0.377	0.043	10381	497.1	0.51	1.457
141	2.503	2.114	0.379	0.045	10377	504.2	0.51	1.456
142	2.631	2.098	0.379	0.043	10315	501.5	0.52	1.456
143	2.639	2.091	0.379	0.039	10227	500.2	0.52	1.457
144	2.593	2.090	0.378	0.043	10217	501.6	0.52	1.456
145	2.726	2.091	0.378	0.047	10204	506.8	0.52	1.457
146	2.767	2.101	0.379	0.046	10150	513.1	0.51	1.457

Concentration Values Reported from Innovative Nonlinear Algorithm (Continued)

File	CH₄	CO	N₂O	SF₆	H₂O	CO₂	shift	res
147	2.770	2.111	0.378	0.046	10140	516.4	0.52	1.458
148	2.686	2.108	0.379	0.044	10181	518.5	0.51	1.459
149	2.641	2.108	0.379	0.042	10160	522.4	0.51	1.460
150	2.851	2.097	0.379	0.042	10102	535.6	0.51	1.460
151	2.857	2.091	0.379	0.043	10075	536.3	0.51	1.461
152	2.813	2.095	0.379	0.046	10022	533.9	0.51	1.461
153	2.680	2.091	0.379	0.046	9923	525.5	0.51	1.461
154	2.749	2.115	0.380	0.044	9860	533.2	0.51	1.462
155	2.749	2.102	0.380	0.045	9846	532.7	0.52	1.461
156	2.738	2.093	0.380	0.045	9836	530.1	0.52	1.462
157	2.547	2.103	0.380	0.044	9872	514.4	0.52	1.463
158	2.463	2.099	0.380	0.043	9817	512.3	0.52	1.462
159	2.366	2.103	0.380	0.043	9773	510.1	0.52	1.462
160	2.468	2.114	0.380	0.041	9762	520.2	0.52	1.461
161	2.579	2.128	0.379	0.044	9736	532.1	0.52	1.463
162	2.577	2.149	0.380	0.045	9748	535.4	0.51	1.461
163	2.595	2.198	0.379	0.045	9648	538.0	0.51	1.463
164	2.609	2.239	0.380	0.044	9654	534.9	0.52	1.462
165	2.582	2.148	0.380	0.043	9706	525.5	0.52	1.462
166	2.542	2.132	0.380	0.045	9738	534.9	0.52	1.463
167	2.521	2.139	0.382	0.047	9767	539.0	0.52	1.463
168	2.425	2.117	0.381	0.047	9738	532.2	0.52	1.463
169	2.403	2.134	0.381	0.047	9727	529.4	0.52	1.463
170	2.297	2.153	0.381	0.045	9728	524.3	0.52	1.463
171	2.168	2.216	0.381	0.044	9718	530.1	0.52	1.464
172	2.180	2.129	0.381	0.046	9662	528.5	0.52	1.462
173	2.334	2.141	0.380	0.047	9559	539.1	0.52	1.464
174	2.360	2.120	0.380	0.045	9490	540.5	0.52	1.464
175	2.201	2.123	0.380	0.046	9599	527.1	0.52	1.465

Concentration Values Reported from Innovative Nonlinear Algorithm (Continued)

File	CH₄	CO	N₂O	SF₆	H₂O	CO₂	shift	res
176	2.160	2.141	0.382	0.045	9594	523.2	0.52	1.464
177	2.187	2.143	0.381	0.048	9573	521.2	0.52	1.464
178	2.260	2.136	0.381	0.044	9563	519.6	0.51	1.465
179	2.282	2.129	0.381	0.045	9543	520.4	0.52	1.464
180	2.150	2.220	0.381	0.045	9498	520.5	0.52	1.466
181	2.067	2.136	0.381	0.047	9531	515.4	0.52	1.465
182	2.070	2.126	0.382	0.049	9560	516.2	0.52	1.465
183	2.078	2.125	0.381	0.044	9552	516.8	0.52	1.465
184	2.173	2.170	0.381	0.046	9421	530.4	0.52	1.465
185	2.172	2.157	0.381	0.048	9404	529.8	0.52	1.466
186	2.086	2.132	0.381	0.048	9458	520.0	0.52	1.466
187	2.065	2.128	0.381	0.045	9526	518.4	0.52	1.466
188	2.031	2.131	0.381	0.044	9639	507.1	0.52	1.465
189	2.050	2.132	0.382	0.041	9648	509.8	0.52	1.466
190	2.102	2.137	0.381	0.044	9709	510.6	0.52	1.465
191	2.219	2.140	0.382	0.043	9735	511.5	0.51	1.466
192	2.366	2.136	0.381	0.046	9798	509.4	0.52	1.465
193	2.427	2.154	0.381	0.045	9859	506.6	0.52	1.467
194	2.435	2.177	0.381	0.048	9847	506.4	0.52	1.467
195	2.557	2.192	0.381	0.047	9827	506.1	0.52	1.466
196	3.073	2.188	0.381	0.047	9859	506.0	0.52	1.465
197	4.122	2.165	0.382	0.047	9890	506.4	0.52	1.467
198	4.348	2.168	0.382	0.044	9808	514.2	0.52	1.467
199	4.267	2.176	0.382	0.043	9602	526.2	0.52	1.467
200	3.534	2.166	0.382	0.045	9478	528.7	0.52	1.467
201	2.950	2.144	0.380	0.047	9298	536.2	0.52	1.467
202	2.790	2.137	0.381	0.045	9243	540.4	0.52	1.467
203	3.046	2.140	0.382	0.044	9375	545.5	0.52	1.467
204	2.855	2.124	0.382	0.043	9414	546.3	0.52	1.468

Concentration Values Reported from Innovative Nonlinear Algorithm (Continued)

File	CH₄	CO	N₂O	SF₆	H₂O	CO₂	shift	res
205	2.638	2.133	0.383	0.045	9309	539.0	0.52	1.468
206	2.517	2.139	0.383	0.045	9250	533.3	0.52	1.468
207	2.398	2.138	0.383	0.047	9180	531.7	0.52	1.468
208	2.375	2.139	0.382	0.045	8948	544.0	0.52	1.468
209	2.393	2.134	0.383	0.045	8781	547.6	0.52	1.467
210	2.370	2.139	0.382	0.045	8702	548.2	0.52	1.469
211	2.340	2.142	0.383	0.043	8710	543.1	0.52	1.468
212	2.265	2.125	0.382	0.045	8774	536.3	0.52	1.468
213	2.255	2.125	0.383	0.046	8808	530.4	0.52	1.467
214	2.250	2.133	0.383	0.046	8821	526.4	0.52	1.469
215	2.230	2.160	0.383	0.046	8747	528.6	0.52	1.469
216	2.267	2.142	0.385	0.045	8726	528.1	0.52	1.470
217	2.293	2.137	0.384	0.044	8786	524.0	0.52	1.471
218	2.320	2.138	0.385	0.045	8695	529.3	0.52	1.470
219	2.297	2.143	0.385	0.047	8610	529.6	0.51	1.472
220	2.265	2.177	0.386	0.045	8595	525.5	0.51	1.472
221	2.336	2.231	0.386	0.043	8483	534.2	0.52	1.474
222	2.373	2.190	0.384	0.046	8522	532.3	0.52	1.472
223	2.492	2.188	0.384	0.043	8462	539.7	0.52	1.472
224	2.704	2.231	0.384	0.042	8569	537.6	0.52	1.471
225	2.755	2.220	0.384	0.045	8788	527.7	0.52	1.470
226	2.981	2.253	0.385	0.049	8594	538.1	0.52	1.471
227	2.871	2.251	0.384	0.047	8567	537.1	0.52	1.473
228	2.653	2.235	0.385	0.046	8646	525.2	0.52	1.471
229	2.850	2.226	0.385	0.047	8735	521.1	0.52	1.470
230	2.647	2.206	0.385	0.047	8676	524.2	0.51	1.470
231	2.670	2.181	0.385	0.041	8673	530.5	0.52	1.471
232	3.004	2.202	0.386	0.043	8711	532.9	0.51	1.470
233	3.396	2.208	0.385	0.049	8693	536.8	0.52	1.471

Concentration Values Reported from Innovative Nonlinear Algorithm (Continued)

File	CH₄	CO	N₂O	SF₆	H₂O	CO₂	shift	res
234	4.291	2.234	0.384	0.045	8915	537.6	0.52	1.470
235	5.124	2.243	0.385	0.045	9043	535.2	0.52	1.471
236	4.369	2.260	0.384	0.047	8649	545.8	0.52	1.472
237	3.664	2.266	0.385	0.045	8697	537.2	0.52	1.471
238	3.562	2.253	0.384	0.046	8754	532.8	0.52	1.470
239	3.367	2.260	0.385	0.047	8771	531.6	0.52	1.471
240	3.291	2.233	0.385	0.048	8735	537.9	0.51	1.471
241	3.322	2.215	0.385	0.047	8760	536.9	0.52	1.471
242	3.084	2.219	0.387	0.047	8589	539.0	0.51	1.472
243	2.947	2.218	0.385	0.043	8452	543.3	0.51	1.475
244	2.914	2.232	0.385	0.044	8238	556.0	0.51	1.475
245	2.945	2.228	0.386	0.045	8322	543.6	0.51	1.475
246	2.892	2.207	0.386	0.046	8295	543.3	0.51	1.476
247	2.900	2.225	0.384	0.047	8323	541.0	0.52	1.475
248	2.778	2.291	0.384	0.046	8264	536.8	0.52	1.475
249	2.665	2.227	0.385	0.045	8183	534.9	0.52	1.475
250	2.589	2.209	0.385	0.047	8100	538.7	0.52	1.475
251	2.557	2.197	0.385	0.047	8076	540.7	0.52	1.476
252	2.707	2.208	0.386	0.045	8142	538.8	0.52	1.475
253	2.803	2.221	0.385	0.045	8199	536.3	0.52	1.475
254	2.485	2.215	0.386	0.044	8237	537.9	0.51	1.476
255	2.261	2.205	0.386	0.048	8288	555.2	0.51	1.475
256	2.325	2.273	0.386	0.046	8217	557.9	0.51	1.475
257	2.371	2.298	0.386	0.047	8088	552.0	0.51	1.476
258	2.413	2.300	0.386	0.046	8021	558.3	0.51	1.477
259	2.428	2.312	0.386	0.042	7953	572.4	0.51	1.477
260	2.460	2.276	0.386	0.046	7825	568.9	0.51	1.478
261	2.464	2.301	0.386	0.044	7918	559.1	0.52	1.477
262	2.470	2.264	0.387	0.047	8060	540.2	0.51	1.476

Concentration Values Reported from Innovative Nonlinear Algorithm (Continued)

File	CH₄	CO	N₂O	SF₆	H₂O	CO₂	shift	res
263	2.568	2.285	0.387	0.048	8127	533.8	0.52	1.474
264	2.587	2.260	0.387	0.046	8154	531.9	0.52	1.476
265	2.495	2.246	0.387	0.049	8082	534.3	0.52	1.476
266	2.559	2.248	0.388	0.044	8038	533.6	0.52	1.476
267	2.548	2.255	0.388	0.045	7920	538.3	0.51	1.478
268	2.519	2.343	0.388	0.046	7872	538.0	0.51	1.479
269	2.485	2.338	0.388	0.045	7815	538.3	0.51	1.479
270	2.463	2.323	0.389	0.046	7848	537.6	0.51	1.479
271	2.458	2.361	0.388	0.044	7885	541.8	0.51	1.479
272	2.423	2.409	0.388	0.044	7941	540.9	0.51	1.479
273	2.575	2.917	0.389	0.044	8034	541.7	0.51	1.478
274	3.139	2.704	0.390	0.045	8166	544.4	0.52	1.475
275	3.036	2.469	0.389	0.047	8080	545.8	0.52	1.476
276	2.979	2.401	0.390	0.046	8067	540.1	0.52	1.476
277	2.929	2.421	0.389	0.045	8053	541.6	0.52	1.476
278	2.844	2.615	0.389	0.045	8004	556.1	0.52	1.476
279	2.761	2.684	0.389	0.045	8029	552.7	0.52	1.476
280	2.693	2.691	0.389	0.043	8081	554.9	0.51	1.477
281	2.720	2.769	0.388	0.044	8076	560.4	0.51	1.476
282	2.723	2.721	0.388	0.042	8048	555.5	0.51	1.477
283	2.703	2.668	0.389	0.040	7941	554.2	0.51	1.478
284	2.702	2.619	0.389	0.044	7874	553.3	0.51	1.479
285	2.719	3.052	0.390	0.045	7840	558.0	0.51	1.479
286	2.729	2.973	0.389	0.042	7896	567.4	0.51	1.478
287	2.745	3.077	0.389	0.043	7825	574.0	0.52	1.478
288	2.784	3.109	0.389	0.044	7981	580.4	0.52	1.477
289	2.904	3.053	0.389	0.045	7995	579.9	0.52	1.476
290	2.923	3.027	0.389	0.057	8077	578.8	0.52	1.476
291	2.949	3.107	0.389	0.062	7954	583.2	0.52	1.476

Concentration Values Reported from Innovative Nonlinear Algorithm (Continued)

File	CH₄	CO	N₂O	SF₆	H₂O	CO₂	shift	res
292	3.014	3.215	0.389	0.015	7932	588.1	0.52	1.477
293	3.133	3.334	0.388	0.007	7932	597.7	0.51	1.478
294	3.222	3.155	0.389	0.005	8064	583.6	0.51	1.477
295	3.011	2.890	0.389	0.004	8254	568.3	0.51	1.476
296	2.959	2.930	0.389	0.003	8324	566.9	0.51	1.476
297	2.987	2.831	0.389	0.002	8337	568.4	0.51	1.476
298	2.959	2.752	0.389	0.002	8369	569.2	0.51	1.476
299	2.960	2.703	0.388	0.002	8437	566.1	0.52	1.476
300	3.109	2.848	0.389	0.002	8556	562.9	0.52	1.473
301	3.109	2.849	0.390	0.001	8676	555.2	0.52	1.473
302	3.026	2.743	0.391	0.001	8790	551.0	0.52	1.473
303	3.025	2.682	0.396	0.001	8906	549.0	0.52	1.472
304	3.156	2.708	0.402	0	8964	545.4	0.52	1.471
305	3.248	2.715	0.404	0.001	9011	544.6	0.52	1.470
306	3.329	2.735	0.404	0.001	9069	545.3	0.52	1.473
average	2.758	2.208	0.382	0.041	9496	519.2	0.51	1.462
std	0.726	0.248	0.01	0.01	879	24.4	0	0.011

Appendix C

**FTIR Spectral Analyses Conducted
by ARCADIS Geraghty & Miller (David Natschke)**

(Intentionally Blank)

MEMO

ARCADIS Geraghty & Miller, Inc.
P.O. Box 13109
Research Triangle Park
North Carolina 27709
Tel 919 544 4535
Fax 919 544 5690

To:
John Kinsey
US EPA, APPCD

From:
David F. Natschke

Date:
27 September 2000

Subject:
Report on the Analysis of Open Path FTIR Data from the Chlor-Alkali Plant

Introduction

EPA supplied two open path FTIR data sets. The first consisted of ten *Iomega*[®] *Zip* disks that included .spc files. These files were single beam sample spectra collected by USEPA Region IV personnel. The second data set consisted of 1 *Fujitsu* magneto optical (MO) disk that included .spc files. These files were absorbance spectra “packed” as “multifiles” and consisted of upwind (background) spectra collected by USEPA/APPCCD personnel, which had already been processed from raw interferograms to absorbance by EPA. The “spc” suffix indicates a data file format used by *MIDAC*, *Galactic Industries*, and others for spectral data.

The processing steps consisted of obtaining the appropriate software, file transfer and organization, packing the individual files as multifiles, conversion to absorbance, unpacking the multifiles to individual absorbance files, processing through the *AutoQuant*[®] program, and results organization. These steps are described in the following sections.

Obtaining the Software

Two software packages were needed to accomplish this task: *GRAMS/32*[®] and *AutoQuant*[®]. *GRAMS/32*[®] was needed for the processing of the .spc files, while *AutoQuant*[®] is the quantification package. *GRAMS/32*[®] is a *Galactic Industries* product that may also be obtained through MIDAC Corporation and other instrument manufacturers. *AutoQuant*[®] is a *MIDAC Corporation* product. Both

packages were obtained from *MIDAC*. The “non-collect” version of *GRAMS/32*[®] was purchased, as this was sufficient for the task and slightly less expensive.

File Transfer and Organization

Sample spectra were obtained as .spc files on 10 *Zip* disks. Arcadis found that the files were highly disorganized with many duplicates and files from sequential samples spread across multiple disks. In a few cases, an individual file was completely missing. Many irrelevant files, unknown purpose, were also included.

The disks were manually cataloged to determine the location of sequential sample files and to identify missing files. A total of 1,964 unique data files from seven nominal sampling dates were identified. Unique files were then transferred to hard disk and organized in directories by nominal sampling date. These files were then archived to a recordable CD before any file manipulation was performed. The following table describes the number of sample files identified by sampling date.

Table 1. Samples by Date Prefix

<u>Sampling date prefix</u>	<u>Number of sample files</u>
D0217	1
D0218	276
D0219	327
D0220	501
D0222	272
D0223	282
D0224	305

Packing Individual Files as Multifiles

The spectra were in single beam format. While not critical, the conversion to multifile format is a tremendous time saver prior to calculation of absorbance spectra. The multifile format permits spectral arithmetic operations to be performed on all members of a multifile with a single command.

The first file manipulation performed was, therefore, packing as multifiles. *GRAMS/32*[®] was used for this conversion. As implemented there is a limit of 60 files that can be packed into a single file. For

convenience, 50 files were placed in the typical multifile. These files were named with the sampling date prefixes described in Table 1 with the addition of a single letter suffix and then archived to a separate subdirectory on the hard disk.

Conversion to Absorbance

Spectra must be converted to absorbance prior to any quantification, based upon the following equation:

$$\text{Abs} = -\log\left(\frac{I}{I_0}\right)$$

In this equation, I refers to the single beam spectrum while I_0 is a reference spectrum.

In open path FTIR, it is difficult to obtain a true reference spectrum. The full optical path can rarely be contained and purged of all infrared active compounds. A number of techniques have been used to generate a useful reference spectrum. It is sometimes possible to obtain a valid upwind spectrum that is free from the compounds of interest. Another technique calls for the generation of a “synthetic background” spectrum, usually by taking a spectrum and removing all known spectral features from it. The synthetic background spectrum is often generated manually, though it may also be generated by fitting some function, for example a spline function, to the baseline of the single beam reference spectrum.

EPA supplied a synthetic background spectrum for use with this data set. The generated multifiles were converted to absorbance using this reference spectrum. The absorbance multifiles were archived to hard disk in separate subdirectories.

Unpacking the Multifiles to Individual Absorbance Files

Since *AutoQuant*[®] cannot deal with absorbance multifiles *GRAMS/32*[®] was used to separate multifiles into individual files. The individual files were archived to hard disk.

Processing through the *AutoQuant*[®] Program

AutoQuant[®] requires one or more “method” files, the supporting calibration spectra with concentration data, and sample absorbance spectra. EPA supplied three method files and all the associated calibration spectra for use in the quantification of these data.

In use, a given method is calibrated with the supplied calibration spectra and then applied to the selected spectrum or spectra (batch mode). For these calculations, three separate methods were needed. Each was applied sequentially to the selected set of spectra. Results are in ppm. Results were archived to hard disk as .txt files.

Organization of Results

The *AutoQuant*[®] results were imported into *Excel*[®] spreadsheets, 1 per sampling date, as multiple .txt files. Since *AutoQuant*[®] does not maintain the original sample order in its results file, results were sorted within *Excel*[®] by sample name (number) to restore the original order.

The original sample date and time had been “lost” (not transferred) by either *GRAMS/32*[®] during the conversions to and from multifiles or *AutoQuant*[®]. Examination of individual absorbance files within *GRAMS/32*[®] shows that the sampling date and time are still attached internally after all manipulations were completed. The original sampling date and time were recovered by using the DOS command: **dir >> dir.txt** within each of the single beam subdirectories. This ASCII file was then imported into the *Excel*[®] spreadsheets and aligned with the results data. Printouts of these files are included with this memo.

Upwind Data

Separate from the sampling performed by Region IV personnel, upwind data were independently collected by APPCD personnel and equipment. These data were provided separately to Arcadis. Arcadis found that all the preliminary data manipulation had already been performed and that spectra already existed as individual absorbance files ready for *AutoQuant*[®]. Because these data were collected on a different instrument and at a different spectral resolution, the method files and calibration spectra used for the samples were not appropriate to the upwind spectra. EPA also provided the correct method file and calibration spectra.

Quantification and results processing were performed as described above for the 60 files generated on 2/14/00. Examination of the individual results revealed 2 sets of the 60 that had questionable results for one or more compounds. The errors associated with these concentrations were much higher than the other 58 for the same compound. USEPA personnel had made the same observations during calculation of this data set. These two samples were, therefore, eliminated after examining the original spectra and results from these two samples were not used in the calculation of average upwind concentrations.

The individual results from the upwind samples were used to calculate average concentrations and the standard deviation. These values were then used to calculate a detection limit for each compound based upon the typical equation:

$$\text{Detection_limit} = \text{mean} + 3 * \sigma$$

where σ is the standard deviation.

Arcadis used a slight deviation from the above equation in calculating a detection limit for SF₆. As the Table 2 shows, both the average and the standard deviation for this compound are 0. For this compound only, Arcadis used the average error reported by *AutoQuant*[®] in place of the standard deviation.

Table 2. Results for Upwind Data, including Estimated Detection Limits

Results are in ppm	Carbon Monoxide	Methane	Nitrous Oxide	Sulfur Hexafluoride
Average	0.264	1.795	0.301	0
Standard Deviation	0.155	0.031	0.004	0
Detection Limit	0.729	1.887	0.312	0.000241

Intercomparison

Hardcopies of the results spreadsheets are being delivered with this memo/report. Of these, spectra from 2/24/2000 were separately analyzed by Mantech; these results were supplied by the WAM. Arcadis results were compared point by point with the Mantech results. These comparisons are found in the four attached graphs. It can be stated that differences are minor to none and are within the *AutoQuant*[®] reported errors. Trendlines were established for methane, carbon monoxide, nitrous oxide, and sulfur hexafluoride. These results are reported in Table 3.

Table 3. Intercomparison Results

	Slope	Intercept	R²
Methane	0.9988	0.0057	1
Carbon monoxide	0.9735	0.0074	0.9986
Nitrous oxide	1.0064	-0.0013	0.9965
Sulfur hexafluoride	1	0	1

These factors refer to Mantech results as the independent variable (x) and Arcadis results as the dependent variable (y).

The Mantech and Arcadis results may be considered identical for all practical purposes.

Table C-1. HANST SCREENING METHOD + Sulfur Hexafluoride

Upwind Data for the Chlor-Alkali Testing Study.

Data collected on the Midac Instrument @ 0.5 cm⁻¹ resolution.

		Results Are in Parts per Million								
		ammonia	carbon monoxide	carbon dioxide	methane	nitrous oxide	sulfur hexafluoride	water method 1	water method 2	water method 3
absorb.spc	2/14/00 11:13	0.003	0.643	352	1.8	0.3	0	18035	16648	16297
ol014001.spc	2/14/00 11:13	0.003	0.643	352	1.8	0.30	0	18,035	16,648	16,297
ol014002.spc	2/14/00 11:13	0.001	0.295	353	1.7	0.3	0	17940	16581	16616
ol014003.spc	2/14/00 11:13	0.002	0.265	357	1.8	0.30	0	18,222	17,471	16,743
ol014004.spc	2/14/00 11:13	0	0.191	342	1.8	0.30	0	18,004	16,565	15,496
ol014005.spc	2/14/00 11:13	0.001	0.225	348	1.8	0.30	0	18,349	16,725	16,303
ol014006.spc	2/14/00 11:13	0.002	0.548	353	1.8	0.29	0	17,912	16,455	16,113
ol014007.spc	2/14/00 11:13	0.002	0.457	345	1.8	0.29	0	17,575	16,006	16,135
ol014008.spc	2/14/00 11:13	0.003	0.761	358	1.8	0.30	0	18,359	17,049	16,188
ol014009.spc	2/14/00 11:13	0.001	0.592	357	1.7	0.30	0	18,100	16,714	16,266
ol014010.spc	2/14/00 11:13	0.002	0.452	355	1.8	0.30	0	18,150	16,680	16,728
ol014011.spc	2/14/00 11:13	0.002	0.859	361	1.8	0.29	0	18,101	16,961	16,642
ol014012.spc	2/14/00 11:13	0.001	0.251	357	1.8	0.30	0	18,288	16,818	16,844
ol014013.spc	2/14/00 11:13	0.001	0.268	357	1.8	0.30	0	18,233	16,719	17,129
ol014014.spc	2/14/00 11:13	0.002	0.197	358	1.8	0.31	0	18,172	16,900	16,538
ol014015.spc	2/14/00 11:13	0	0.314	354	1.8	0.30	0	18,232	16,950	16,820
ol014017.spc	2/14/00 11:13	0.005	0.297	365	1.8	0.31	0	18,306	16,717	16,031
ol014018.spc	2/14/00 11:13	0	0.282	356	1.8	0.30	0	18,138	16,758	17,086
ol014019.spc	2/14/00 11:13	0.001	0.189	351	1.8	0.30	0	18,391	16,705	16,974
ol014020.spc	2/14/00 11:13	0	0.168	356	1.8	0.30	0	18,198	16,546	16,723
ol014021.spc	2/14/00 11:13	0.003	0.174	352	1.8	0.30	0	17,919	16,413	16,527
ol014022.spc	2/14/00 11:13	0	0.171	350	1.8	0.30	0	17,947	16,395	16,527
ol014023.spc	2/14/00 11:13	0.001	0.162	356	1.8	0.30	0	17,925	16,534	16,518
ol014024.spc	2/14/00 11:13	0.002	0.159	351	1.8	0.31	0	17,992	16,409	16,623
ol014025.spc	2/14/00 11:13	0.002	0.161	353	1.7	0.30	0	17,780	16,366	16,286
ol014026.spc	2/14/00 11:13	0.001	0.199	351	1.8	0.30	0	17,953	16,495	16,075
ol014027.spc	2/14/00 11:13	0.001	0.167	351	1.8	0.30	0	17,945	16,541	16,547
ol014028.spc	2/14/00 11:13	0.001	0.252	351	1.8	0.30	0	17,842	16,482	16,408
ol014029.spc	2/14/00 11:13	0.002	0.247	354	1.8	0.30	0	17,800	16,453	16,207
ol014030.spc	2/14/00 11:13	0	0.239	356	1.8	0.30	0	17,690	16,283	16,266
ol014031.spc	2/14/00 11:13	0.003	0.192	348	1.8	0.30	0	17,746	16,179	16,231
ol014032.spc	2/14/00 11:13	0.002	0.166	350	1.7	0.30	0	17,404	16,109	16,258
ol014033.spc	2/14/00 11:13	0.002	0.211	350	1.8	0.30	0	17,532	16,139	16,275
ol014034.spc	2/14/00 11:13	0.001	0.192	350	1.8	0.30	0	17,736	16,203	16,414

C-7

Table C-1. HANST SCREENING METHOD + Sulfur Hexafluoride (Continued)

		Results Are in Parts per Million								
		ammonia	carbon monoxide	carbon dioxide	methane	nitrous oxide	sulfur hexafluoride	water method 1	water method 2	water method 3
ol014035.spc	2/14/00 11:13	0.001	0.266	351	1.8	0.30	0	17,983	16,332	16,236
ol014036.spc	2/14/00 11:13	0.002	0.178	349	1.8	0.30	0	17,718	15,976	16,244
ol014037.spc	2/14/00 11:13	0.003	0.181	349	1.8	0.30	0	17,624	15,997	16,065
ol014038.spc	2/14/00 11:13	0.002	0.177	346	1.8	0.31	0	18,194	16,470	16,424
ol014039.spc	2/14/00 11:13	0.004	0.203	350	1.8	0.30	0	17,589	15,774	15,938
ol014040.spc	2/14/00 11:13	0	0.197	346	1.8	0.30	0	17,331	15,753	16,023
ol014041.spc	2/14/00 11:13	0	0.265	346	1.7	0.30	0	17,161	15,142	15,448
ol014042.spc	2/14/00 11:13	0.003	0.22	350	1.8	0.30	0	17,689	15,945	16,160
ol014043.spc	2/14/00 11:13	0.002	0.202	354	1.8	0.30	0	17,159	15,629	16,083
ol014044.spc	2/14/00 11:13	0.002	0.179	355	1.8	0.30	0	17,743	16,312	16,965
ol014045.spc	2/14/00 11:13	0.002	0.178	354	1.9	0.30	0	18,060	16,432	16,945
ol014046.spc	2/14/00 11:13	0.003	0.175	354	1.8	0.30	0	18,030	16,232	16,843
ol014047.spc	2/14/00 11:13	0.003	0.173	348	1.8	0.30	0	17,857	16,001	16,237
ol014048.spc	2/14/00 11:13	0.004	0.215	354	1.8	0.30	0	17,569	15,815	16,205
ol014049.spc	2/14/00 11:13	0	0.234	356	1.8	0.30	0	17,969	16,070	16,630
ol014050.spc	2/14/00 11:13	0.009	0.254	335	1.9	0.28	0	16,803	15,379	15,565
ol014052.spc	2/14/00 11:13	0.002	0.182	354	1.8	0.30	0	17,964	16,300	16,644
ol014053.spc	2/14/00 11:13	0.002	0.181	351	1.8	0.30	0	17,809	16,134	16,590
ol014054.spc	2/14/00 11:13	0.002	0.233	351	1.8	0.30	0	17,879	16,274	16,412
ol014055.spc	2/14/00 11:13	0.001	0.178	344	1.8	0.30	0	17,719	15,931	16,549
ol014056.spc	2/14/00 11:13	0.002	0.179	350	1.8	0.30	0	17,716	15,973	16,656
ol014057.spc	2/14/00 11:13	0.003	0.176	349	1.8	0.30	0	17,808	16,003	16,525
ol014058.spc	2/14/00 11:13	0.001	0.182	350	1.8	0.30	0	17,941	16,342	16,782
ol014059.spc	2/14/00 11:13	0.002	0.176	343	1.8	0.30	0	17,712	15,747	16,524
ol014060.spc	2/14/00 11:13	0.002	0.175	343	1.8	0.30	0	17,466	15,491	16,316
average		0.001864	0.264	352	1.79	0.30	0	17,872	16,323	16,409
std. Dev.		0.001468	0.155	5	0.03	0.00	0	315	431	354
ol014016.spc	2/14/00 11:13	0.01	6.643	3,190	8.4	1.53	0	24,756	363,502	773,663
ol014051.spc	2/14/00 11:13	6.948	0	245	3.4	0.01	0.84	1,142,701	1,087	1306

Table C-2.

C-9

Collection Data			Quantification Method Concentrations in ppm						
			Olin Mercury Plant			Olin 2		Olin 3	
File	Date	Time	sulfur hexafluoride	water	carbon monoxide	nitrous oxide	water	methane	Water
D0218002 SPC	2/18/00	11:45a	0.035	12,484	1.578	0.349	13,934	1.959	10,322
D0218003 SPC	2/18/00	11:52a	0	13,039	1.587	0.349	14,112	1.962	10,415
D0218004 SPC	2/18/00	12:27p	0	13,730	1.57	0.348	14,722	2.184	11,039
D0218005 SPC	2/18/00	12:31p	0	13,721	1.63	0.347	14,723	2.255	11,009
D0218006 SPC	2/18/00	12:36p	0	13,553	1.595	0.347	14,718	2.238	11,043
D0218007 SPC	2/18/00	12:43p	0	13,796	1.581	0.346	14,775	2.312	11,097
D0218008 SPC	2/18/00	12:48p	0.001	13,944	1.582	0.346	14,933	2.332	11,178
D0218009 SPC	2/18/00	12:55p	0.001	13,960	1.587	0.345	14,953	2.342	11,271
D0218010 SPC	2/18/00	1:02p	0.001	14,190	1.59	0.343	15,218	2.328	11,487
D0218011 SPC	2/18/00	1:07p	0.001	14,221	1.585	0.343	15,307	2.353	11,546
D0218012 SPC	2/18/00	1:11p	0	14,394	1.59	0.342	15,437	2.387	11,673
D0218013 SPC	2/18/00	1:16p	0	14,670	1.974	0.345	15,737	2.397	11,885
D0218014 SPC	2/18/00	1:20p	0	15,065	1.624	0.343	16,186	2.178	12,274
D0218015 SPC	2/18/00	1:25p	0	15,470	1.609	0.343	16,779	1.97	12,651
D0218016 SPC	2/18/00	1:29p	0	15,659	1.608	0.341	16,956	1.999	12,823
D0218017 SPC	2/18/00	1:34p	0	15,781	1.607	0.341	17,172	2.062	13,048
D0218018 SPC	2/18/00	1:38p	0	16,076	1.618	0.339	17,348	2.054	13,191
D0218019 SPC	2/18/00	1:43p	0	15,968	1.599	0.339	17,273	2.018	13,073
D0218020 SPC	2/18/00	1:47p	0	16,138	1.61	0.339	17,449	2.088	13,276
D0218021 SPC	2/18/00	1:52p	0	16,549	1.651	0.337	17,866	2.229	13,653
D0218022 SPC	2/18/00	1:56p	0	16,879	1.654	0.337	18,188	2.291	13,915
D0218023 SPC	2/18/00	2:01p	0	16,973	1.64	0.337	18,243	2.593	13,965
D0218024 SPC	2/18/00	2:06p	0	16,929	1.671	0.338	18,311	2.456	14,053
D0218025 SPC	2/18/00	2:10p	0	16,757	1.604	0.338	18,073	2.048	13,930
D0218026 SPC	2/18/00	2:15p	0	16,754	1.6	0.338	18,054	2.002	13,867
D0218027 SPC	2/18/00	2:19p	0	16,962	1.608	0.337	18,288	2.046	14,058
D0218028 SPC	2/18/00	2:24p	0	17,156	1.65	0.338	18,457	2.085	14,223
D0218029 SPC	2/18/00	2:28p	0	17,207	1.642	0.337	18,704	2.062	14,309
D0218030 SPC	2/18/00	2:33p	0	17,234	1.639	0.336	18,693	2.02	14,322
D0218031 SPC	2/18/00	2:37p	0	17,607	1.64	0.334	19,240	2.138	14,516

Table C-2. (Continued)

Collection Data			Quantification Method Concentrations in ppm						
File	Date	Time	Olin Mercury Plant		Olin 2		Olin 3		
			sulfur hexafluoride	water	carbon monoxide	nitrous oxide	water	methane	Water
D0218032 SPC	2/18/00	2:42p	0	17,487	1.66	0.335	19,182	2.046	14,488
D0218033 SPC	2/18/00	2:46p	0	17,530	1.659	0.335	19,234	1.985	14,572
D0218034 SPC	2/18/00	2:51p	0	17,713	1.639	0.334	19,321	2.104	14,662
D0218035 SPC	2/18/00	2:55p	0	17,646	1.644	0.334	19,283	2.081	14,635
D0218036 SPC	2/18/00	3:00p	0	17,759	1.633	0.333	19,405	2.09	14,723
D0218037 SPC	2/18/00	3:04p	0	17,753	1.673	0.333	19,454	2.071	14,788
D0218038 SPC	2/18/00	3:09p	0	17,916	1.642	0.333	19,582	2.027	14,906
D0218039 SPC	2/18/00	3:14p	0	18,141	1.66	0.331	19,780	2.13	15,037
D0218040 SPC	2/18/00	3:18p	0	17,919	1.646	0.333	19,580	2.038	14,890
D0218041 SPC	2/18/00	3:23p	0	18,110	1.656	0.331	19,827	2.187	15,081
D0218042 SPC	2/18/00	3:27p	0	18,242	1.665	0.331	19,949	2.222	15,161
D0218043 SPC	2/18/00	3:32p	0	18,254	1.696	0.331	20,013	2.029	15,236
D0218044 SPC	2/18/00	3:36p	0	18,299	1.681	0.331	19,992	2.138	15,269
D0218045 SPC	2/18/00	3:41p	0	18,543	1.688	0.331	20,184	2.168	15,409
D0218046 SPC	2/18/00	3:45p	0	18,492	1.694	0.331	20,189	2.049	15,435
D0218047 SPC	2/18/00	3:50p	0	18,568	1.701	0.33	20,233	2.115	15,487
D0218048 SPC	2/18/00	3:54p	0	18,553	1.746	0.33	20,215	2.029	15,487
D0218049 SPC	2/18/00	3:59p	0	18,722	1.728	0.329	20,353	2.234	15,657
D0218050 SPC	2/18/00	4:03p	0	18,653	1.654	0.328	20,230	2.005	15,529
D0218051 SPC	2/18/00	4:08p	0	18,541	1.648	0.329	20,273	2.164	15,601
D0218052 SPC	2/18/00	4:12p	0	18,706	1.662	0.329	20,339	2.295	15,675
D0218053 SPC	2/18/00	4:17p	0	18,803	1.681	0.329	20,423	2.099	15,757
D0218054 SPC	2/18/00	4:21p	0	18,882	1.677	0.328	20,486	2.043	15,852
D0218055 SPC	2/18/00	4:26p	0	19,015	1.666	0.328	20,505	2.225	15,848
D0218056 SPC	2/18/00	4:30p	0	18,961	1.693	0.328	20,468	2.314	15,736
D0218057 SPC	2/18/00	4:35p	0	19,075	1.691	0.328	20,580	2.299	15,910
D0218058 SPC	2/18/00	4:40p	0	19,018	1.669	0.327	20,534	2.209	15,866
D0218059 SPC	2/18/00	4:44p	0	19,210	1.673	0.326	20,691	2.415	15,966
D0218060 SPC	2/18/00	4:49p	0	19,118	1.672	0.327	20,604	2.472	15,878
D0218061 SPC	2/18/00	4:53p	0	19,150	1.669	0.327	20,581	2.257	15,905

C-10

Table C-2. (Continued)

Collection Data			Quantification Method Concentrations in ppm						
File	Date	Time	Olin Mercury Plant		Olin 2		Olin 3		
			sulfur hexafluoride	water	carbon monoxide	nitrous oxide	water	methane	Water
D0218062 SPC	2/18/00	4:58p	0	19,357	1.67	0.327	20,771	2.625	16,110
D0218063 SPC	2/18/00	5:02p	0	19,318	1.678	0.327	20,719	2.443	16,029
D0218064 SPC	2/18/00	5:07p	0	19,434	1.673	0.327	20,764	2.958	16,078
D0218065 SPC	2/18/00	5:11p	0	19,104	1.67	0.327	20,500	2.667	15,774
D0218066 SPC	2/18/00	5:16p	0	18,930	1.676	0.328	20,407	2.413	15,650
D0218067 SPC	2/18/00	5:20p	0	18,903	1.693	0.329	20,331	2.345	15,519
D0218068 SPC	2/18/00	5:25p	0	18,791	1.682	0.328	20,255	2.207	15,403
D0218069 SPC	2/18/00	5:29p	0	18,723	1.68	0.329	20,266	2.375	15,371
D0218070 SPC	2/18/00	5:34p	0	18,744	1.68	0.329	20,257	2.254	15,390
D0218071 SPC	2/18/00	5:38p	0	18,688	1.678	0.329	20,150	2.165	15,297
D0218072 SPC	2/18/00	5:43p	0	18,584	1.7	0.33	20,182	2.014	15,329
D0218073 SPC	2/18/00	5:53p	0	18,659	1.698	0.33	20,238	2.105	15,429
D0218074 SPC	2/18/00	5:58p	0	18,597	1.693	0.329	20,225	2.097	15,428
D0218075 SPC	2/18/00	6:03p	0	18,552	1.699	0.33	20,129	2.072	15,357
D0218076 SPC	2/18/00	6:07p	0	18,532	1.706	0.33	20,131	2.079	15,346
D0218077 SPC	2/18/00	6:12p	0	18,505	1.711	0.33	20,159	2.079	15,416
D0218078 SPC	2/18/00	6:16p	0	18,589	1.728	0.331	20,219	2.072	15,449
D0218079 SPC	2/18/00	6:21p	0	18,704	1.726	0.331	20,253	2.03	15,502
D0218080 SPC	2/18/00	6:25p	0	18,669	1.719	0.331	20,260	1.971	15,533
D0218081 SPC	2/18/00	6:30p	0	18,710	1.731	0.331	20,274	2.004	15,521
D0218082 SPC	2/18/00	6:34p	0	18,697	1.731	0.332	20,295	1.953	15,548
D0218083 SPC	2/18/00	6:39p	0	18,580	1.741	0.332	20,303	1.953	15,495
D0218084 SPC	2/18/00	6:43p	0	18,692	1.776	0.332	20,323	1.934	15,496
D0218085 SPC	2/18/00	6:48p	0	18,687	1.807	0.333	20,341	1.961	15,597
D0218086 SPC	2/18/00	6:52p	0	18,666	1.827	0.333	20,330	1.954	15,616
D0218087 SPC	2/18/00	6:57p	0	18,628	1.905	0.334	20,365	1.952	15,684
D0218088 SPC	2/18/00	7:01p	0	18,641	1.921	0.334	20,374	1.949	15,685
D0218089 SPC	2/18/00	7:06p	0	18,694	1.823	0.333	20,393	1.939	15,727
D0218090 SPC	2/18/00	7:10p	0	18,645	1.823	0.333	20,378	1.964	15,654
D0218091 SPC	2/18/00	7:15p	0	18,713	1.852	0.333	20,411	2.019	15,567

Table C-2. (Continued)

Collection Data			Quantification Method Concentrations in ppm						
File	Date	Time	Olin Mercury Plant		Olin 2		Olin 3		
			sulfur hexafluoride	water	carbon monoxide	nitrous oxide	water	methane	Water
D0218092 SPC	2/18/00	7:19p	0	18,702	1.927	0.334	20,420	2.072	15,430
D0218093 SPC	2/18/00	7:24p	0	18,554	1.953	0.335	20,381	2.171	15,370
D0218094 SPC	2/18/00	7:28p	0	18,436	1.958	0.335	20,303	2.238	15,348
D0218095 SPC	2/18/00	7:33p	0	18,545	1.918	0.335	20,343	2.36	15,373
D0218096 SPC	2/18/00	7:37p	0	18,425	1.89	0.335	20,218	2.511	15,323
D0218097 SPC	2/18/00	7:42p	0.001	18,363	1.87	0.335	20,187	2.541	15,251
D0218098 SPC	2/18/00	7:47p	0	18,497	1.859	0.336	20,266	2.906	15,316
D0218099 SPC	2/18/00	7:51p	0	18,730	1.852	0.335	20,373	4.296	15,272
D0218100 SPC	2/18/00	7:56p	0	19,881	1.869	0.336	20,961	7.328	15,348
D0218101 SPC	2/18/00	8:00p	0	20,131	1.845	0.335	21,174	8.112	15,690
D0218102 SPC	2/18/00	8:05p	0	20,703	1.867	0.335	21,571	9.786	16,117
D0218103 SPC	2/18/00	8:09p	0	20,408	1.886	0.336	21,301	6.981	15,768
D0218104 SPC	2/18/00	8:14p	0	19,794	1.905	0.336	20,896	4.734	15,366
D0218105 SPC	2/18/00	8:18p	0	19,203	1.887	0.337	20,580	4.184	15,177
D0218106 SPC	2/18/00	8:23p	0	18,913	1.87	0.337	20,442	4.971	15,171
D0218107 SPC	2/18/00	8:27p	0	18,806	1.857	0.337	20,430	6.021	15,262
D0218108 SPC	2/18/00	8:32p	0	18,728	1.898	0.338	20,370	5.932	15,179
D0218109 SPC	2/18/00	8:36p	0.001	18,411	1.888	0.338	20,139	4.93	14,947
D0218110 SPC	2/18/00	8:41p	0.001	18,120	1.903	0.339	19,906	3.817	14,737
D0218111 SPC	2/18/00	8:45p	0	17,991	1.953	0.34	19,863	2.416	14,827
D0218112 SPC	2/18/00	8:50p	0.001	17,990	1.973	0.34	19,813	2.25	14,909
D0218113 SPC	2/18/00	8:54p	0.001	17,742	1.94	0.339	19,649	2.165	14,909
D0218114 SPC	2/18/00	8:59p	0.001	17,861	1.94	0.339	19,694	2.3	14,885
D0218115 SPC	2/18/00	9:04p	0.001	17,665	1.992	0.341	19,481	2.426	14,690
D0218116 SPC	2/18/00	9:08p	0.002	17,717	1.988	0.341	19,567	2.766	14,714
D0218117 SPC	2/18/00	9:13p	0.002	17,918	1.943	0.34	19,697	3.778	14,743
D0218118 SPC	2/18/00	9:17p	0.002	17,839	1.93	0.34	19,646	4.143	14,702
D0218119 SPC	2/18/00	9:22p	0.002	17,872	1.91	0.34	19,702	3.834	14,744
D0218120 SPC	2/18/00	9:26p	0.002	17,928	1.913	0.34	19,766	4.842	14,766
D0218121 SPC	2/18/00	9:31p	0.002	18,079	1.896	0.34	19,869	6.23	14,795

Table C-2. (Continued)

Collection Data			Quantification Method Concentrations in ppm						
File	Date	Time	Olin Mercury Plant		Olin 2		Olin 3		
			sulfur hexafluoride	water	carbon monoxide	nitrous oxide	water	methane	Water
D0218122 SPC	2/18/00	9:35p	0.002	18,144	1.881	0.34	19,958	7.44	14,840
D0218123 SPC	2/18/00	9:40p	0.001	18,086	1.879	0.341	19,956	7.218	14,868
D0218124 SPC	2/18/00	9:44p	0.002	18,119	1.89	0.34	19,865	6.1	14,849
D0218125 SPC	2/18/00	9:49p	0.002	18,123	1.897	0.34	19,972	5.923	14,933
D0218126 SPC	2/18/00	9:53p	0.001	18,478	1.874	0.339	20,224	6.706	15,245
D0218127 SPC	2/18/00	9:58p	0.001	18,814	1.85	0.337	20,422	7.918	15,487
D0218128 SPC	2/18/00	10:02p	0.001	18,883	1.843	0.338	20,424	7.272	15,487
D0218129 SPC	2/18/00	10:07p	0.001	18,945	1.851	0.338	20,480	7.878	15,460
D0218130 SPC	2/18/00	10:12p	0.001	19,113	1.855	0.339	20,526	7.137	15,466
D0218131 SPC	2/18/00	10:16p	0	19,160	1.853	0.338	20,642	6.056	15,606
D0218132 SPC	2/18/00	10:21p	0	19,168	1.843	0.338	20,676	5.206	15,777
D0218133 SPC	2/18/00	10:25p	0.001	19,227	1.824	0.337	20,703	5.133	15,942
D0218134 SPC	2/18/00	10:30p	0.001	19,144	1.809	0.336	20,703	4.811	16,065
D0218135 SPC	2/18/00	10:34p	0.001	19,085	1.801	0.337	20,690	4.302	16,090
D0218136 SPC	2/18/00	10:39p	0.001	19,096	1.797	0.336	20,655	4.167	16,057
D0218137 SPC	2/18/00	10:43p	0	19,126	1.797	0.337	20,656	3.855	16,120
D0218138 SPC	2/18/00	10:48p	0	19,034	1.8	0.337	20,673	3.478	16,115
D0218139 SPC	2/18/00	10:52p	0	19,049	1.808	0.337	20,672	2.869	16,103
D0218140 SPC	2/18/00	10:57p	0	18,968	1.818	0.338	20,622	2.597	16,048
D0218141 SPC	2/18/00	11:01p	0	19,093	1.823	0.338	20,619	2.258	16,118
D0218142 SPC	2/18/00	11:06p	0	19,128	1.826	0.338	20,706	2.122	16,138
D0218143 SPC	2/18/00	11:10p	0	19,359	1.84	0.338	20,830	2.091	16,299
D0218144 SPC	2/18/00	11:15p	0	19,526	1.865	0.337	21,029	2.207	16,510
D0218145 SPC	2/18/00	11:19p	0	19,554	1.902	0.338	21,129	2.204	16,635
D0218146 SPC	2/18/00	11:24p	0	19,672	1.89	0.337	21,193	2.279	16,669
D0218147 SPC	2/18/00	11:29p	0	19,759	1.881	0.337	21,200	2.23	16,753
D0218148 SPC	2/18/00	11:33p	0	19,421	1.859	0.337	21,015	2.142	16,631
D0218149 SPC	2/18/00	11:38p	0	19,402	1.863	0.337	20,974	2.149	16,579
D0218150 SPC	2/18/00	11:42p	0	19,443	1.873	0.337	21,084	2.18	16,662
D0218151 SPC	2/18/00	11:47p	0	19,304	1.876	0.338	21,045	2.193	16,643

Table C-2. (Continued)

Collection Data			Quantification Method Concentrations in ppm						
File	Date	Time	Olin Mercury Plant		Olin 2		Olin 3		
			sulfur hexafluoride	water	carbon monoxide	nitrous oxide	water	methane	Water
D0218152 SPC	2/18/00	11:51p	0	19,281	1.877	0.338	20,927	2.177	16,547
D0218153 SPC	2/18/00	11:56p	0	18,983	1.86	0.338	20,652	2.131	16,232
D0218154 SPC	2/19/00	12:00a	0	18,808	1.858	0.338	20,524	2.157	16,069
D0218155 SPC	2/19/00	12:05a	0	18,686	1.854	0.338	20,428	2.144	15,929
D0218156 SPC	2/19/00	12:09a	0	18,846	1.866	0.338	20,517	2.205	15,931
D0218157 SPC	2/19/00	12:14a	0	18,764	1.878	0.337	20,498	2.213	15,927
D0218158 SPC	2/19/00	12:18a	0	18,472	1.871	0.338	20,280	2.2	15,647
D0218159 SPC	2/19/00	12:23a	0	17,854	1.85	0.339	19,686	2.052	15,082
D0218160 SPC	2/19/00	12:27a	0	17,736	1.845	0.339	19,557	2.061	14,934
D0218161 SPC	2/19/00	12:32a	0	17,403	1.847	0.341	19,252	2.091	14,672
D0218162 SPC	2/19/00	12:36a	0	17,355	1.85	0.34	19,136	2.045	14,569
D0218163 SPC	2/19/00	12:41a	0	17,379	1.855	0.339	19,129	2.075	14,505
D0218164 SPC	2/19/00	12:46a	0	17,087	1.837	0.339	18,732	2.087	14,338
D0218165 SPC	2/19/00	12:50a	0	16,961	1.838	0.339	18,336	2.154	14,137
D0218166 SPC	2/19/00	12:55a	0	17,003	1.848	0.339	18,388	2.161	14,177
D0218167 SPC	2/19/00	12:59a	0	16,695	1.846	0.34	18,111	2.134	13,937
D0218168 SPC	2/19/00	1:04a	0	16,473	1.839	0.34	17,922	2.156	13,728
D0218169 SPC	2/19/00	1:08a	0	16,540	1.843	0.339	17,942	2.179	13,705
D0218170 SPC	2/19/00	1:13a	0	16,537	1.849	0.34	17,880	2.106	13,670
D0218171 SPC	2/19/00	1:17a	0	16,301	1.841	0.34	17,694	2.032	13,479
D0218172 SPC	2/19/00	1:22a	0	16,331	1.843	0.34	17,661	2.021	13,384
D0218173 SPC	2/19/00	1:26a	0.001	16,265	1.846	0.339	17,629	2.058	13,371
D0218174 SPC	2/19/00	1:31a	0	16,265	1.845	0.34	17,606	1.979	13,303
D0218175 SPC	2/19/00	1:35a	0	16,209	1.843	0.339	17,544	1.9	13,263
D0218176 SPC	2/19/00	1:40a	0	16,209	1.85	0.339	17,572	1.905	13,277
D0218177 SPC	2/19/00	1:45a	0	16,289	1.861	0.339	17,647	1.956	13,317
D0218178 SPC	2/19/00	1:49a	0	16,364	1.86	0.338	17,739	1.972	13,393
D0218179 SPC	2/19/00	1:54a	0.001	16,246	1.854	0.339	17,548	1.88	13,224
D0218180 SPC	2/19/00	1:58a	0.001	16,199	1.855	0.338	17,493	1.865	13,277
D0218181 SPC	2/19/00	2:03a	0.001	16,088	1.86	0.338	17,482	1.877	13,232

Table C-2. (Continued)

Collection Data			Quantification Method Concentrations in ppm						
File	Date	Time	Olin Mercury Plant		Olin 2		Olin 3		
			sulfur hexafluoride	water	carbon monoxide	nitrous oxide	water	methane	Water
D0218182 SPC	2/19/00	2:07a	0.001	16,075	1.862	0.338	17,454	1.868	13,195
D0218183 SPC	2/19/00	2:12a	0.002	16,040	1.867	0.339	17,427	1.868	13,183
D0218184 SPC	2/19/00	2:16a	0.001	16,150	1.867	0.338	17,449	1.88	13,192
D0218185 SPC	2/19/00	2:21a	0.001	16,000	1.867	0.339	17,391	1.858	13,143
D0218186 SPC	2/19/00	2:25a	0.001	16,088	1.862	0.339	17,416	1.863	13,154
D0218187 SPC	2/19/00	2:30a	0.001	16,098	1.859	0.338	17,338	1.865	13,079
D0218188 SPC	2/19/00	2:34a	0.001	16,049	1.865	0.339	17,313	1.879	13,051
D0218189 SPC	2/19/00	2:39a	0.001	16,082	1.857	0.339	17,344	1.889	13,095
D0218190 SPC	2/19/00	2:43a	0.001	16,022	1.859	0.339	17,333	1.91	13,063
D0218191 SPC	2/19/00	2:48a	0.002	16,145	1.869	0.339	17,414	1.981	13,042
D0218192 SPC	2/19/00	2:53a	0.002	16,110	1.865	0.338	17,379	1.979	13,079
D0218193 SPC	2/19/00	2:57a	0.001	16,142	1.859	0.339	17,329	1.943	13,125
D0218194 SPC	2/19/00	3:02a	0.001	16,169	1.868	0.339	17,367	1.996	13,082
D0218195 SPC	2/19/00	3:06a	0.001	16,069	1.866	0.339	17,384	2.04	13,105
D0218196 SPC	2/19/00	3:11a	0	15,997	1.862	0.34	17,336	2.058	13,104
D0218197 SPC	2/19/00	3:15a	0.001	16,144	1.867	0.339	17,466	2.079	13,226
D0218198 SPC	2/19/00	3:20a	0.001	16,135	1.869	0.34	17,507	2.057	13,233
D0218199 SPC	2/19/00	3:24a	0.002	16,196	1.868	0.339	17,528	2.053	13,167
D0218200 SPC	2/19/00	3:29a	0.002	16,265	1.871	0.339	17,569	2.117	13,214
D0218201 SPC	2/19/00	3:33a	0.002	16,247	1.879	0.339	17,587	2.146	13,220
D0218202 SPC	2/19/00	3:38a	0.002	16,218	1.876	0.339	17,599	2.091	13,243
D0218203 SPC	2/19/00	3:42a	0.001	16,320	1.871	0.339	17,634	2.048	13,266
D0218204 SPC	2/19/00	3:47a	0.002	16,428	1.874	0.339	17,685	2.224	13,363
D0218205 SPC	2/19/00	3:52a	0.002	16,236	1.871	0.338	17,663	2.202	13,349
D0218206 SPC	2/19/00	3:56a	0.002	16,350	1.868	0.339	17,713	2.203	13,383
D0218207 SPC	2/19/00	4:01a	0.002	16,486	1.875	0.339	17,837	2.389	13,461
D0218208 SPC	2/19/00	4:05a	0.001	16,566	1.87	0.338	17,820	2.117	13,502
D0218209 SPC	2/19/00	4:10a	0	16,449	1.876	0.339	17,846	2.121	13,588
D0218210 SPC	2/19/00	4:14a	0	16,570	1.883	0.339	17,956	2.147	13,718
D0218211 SPC	2/19/00	4:19a	0.001	16,643	1.882	0.34	17,936	2.059	13,681

Table C-2. (Continued)

Collection Data			Quantification Method Concentrations in ppm						
File	Date	Time	Olin Mercury Plant		Olin 2		Olin 3		
			sulfur hexafluoride	water	carbon monoxide	nitrous oxide	water	methane	Water
D0218212 SPC	2/19/00	4:23a	0.001	16,573	1.886	0.339	17,969	2.083	13,714
D0218213 SPC	2/19/00	4:28a	0.001	16,677	1.885	0.34	18,022	2.119	13,744
D0218214 SPC	2/19/00	4:32a	0.001	16,667	1.883	0.34	18,104	2.071	13,798
D0218215 SPC	2/19/00	4:37a	0.001	16,770	1.875	0.34	18,231	2.014	13,895
D0218216 SPC	2/19/00	4:41a	0	16,910	1.875	0.339	18,355	1.958	14,079
D0218217 SPC	2/19/00	4:46a	0.002	17,033	1.887	0.339	18,608	2.008	14,282
D0218218 SPC	2/19/00	4:51a	0.001	17,167	1.883	0.338	18,797	2.089	14,410
D0218219 SPC	2/19/00	4:55a	0.001	17,374	1.88	0.338	19,082	2.173	14,474
D0218220 SPC	2/19/00	5:00a	0.001	17,349	1.908	0.339	19,248	2.214	14,601
D0218221 SPC	2/19/00	5:04a	0.001	17,506	1.911	0.339	19,355	2.047	14,702
D0218222 SPC	2/19/00	5:09a	0	17,549	1.899	0.339	19,400	2.01	14,759
D0218223 SPC	2/19/00	5:13a	0.001	17,665	1.895	0.338	19,476	2.03	14,858
D0218224 SPC	2/19/00	5:18a	0.001	17,754	1.9	0.338	19,619	2.022	14,979
D0218225 SPC	2/19/00	5:22a	0.002	17,823	1.905	0.338	19,728	2.163	15,054
D0218226 SPC	2/19/00	5:27a	0.001	17,890	1.907	0.338	19,813	2.13	15,184
D0218227 SPC	2/19/00	5:31a	0.001	18,167	1.917	0.338	20,116	2.2	15,456
D0218228 SPC	2/19/00	5:36a	0	18,048	1.919	0.339	20,015	2.284	15,324
D0218229 SPC	2/19/00	5:40a	0	17,920	1.913	0.339	19,857	2.084	15,180
D0218230 SPC	2/19/00	5:45a	0.001	17,895	1.91	0.339	19,853	1.996	15,165
D0218231 SPC	2/19/00	5:49a	0	18,033	1.912	0.339	19,911	1.965	15,276
D0218232 SPC	2/19/00	5:54a	0	18,035	1.917	0.338	20,013	1.945	15,379
D0218233 SPC	2/19/00	5:59a	0	18,082	1.919	0.338	20,072	1.947	15,408
D0218234 SPC	2/19/00	6:03a	0	18,166	1.912	0.338	20,092	1.904	15,462
D0218235 SPC	2/19/00	6:08a	0	18,274	1.909	0.338	20,212	1.875	15,588
D0218236 SPC	2/19/00	6:12a	0.001	18,261	1.905	0.338	20,229	1.865	15,654
D0218237 SPC	2/19/00	6:17a	0.001	18,376	1.908	0.338	20,297	1.854	15,784
D0218238 SPC	2/19/00	6:21a	0	18,339	1.909	0.338	20,315	1.855	15,787
D0218239 SPC	2/19/00	6:26a	0	18,395	1.908	0.338	20,343	1.845	15,860
D0218240 SPC	2/19/00	6:30a	0	18,536	1.91	0.338	20,395	1.842	15,906
D0218241 SPC	2/19/00	6:35a	0	18,538	1.91	0.338	20,419	1.838	15,928

C-16

C-16

Table C-2. (Continued)

Collection Data			Quantification Method Concentrations in ppm						
File	Date	Time	Olin Mercury Plant		Olin 2		Olin 3		
			sulfur hexafluoride	water	carbon monoxide	nitrous oxide	water	methane	Water
D0218242 SPC	2/19/00	6:39a	0	18,534	1.912	0.338	20,430	1.844	16,014
D0218243 SPC	2/19/00	6:44a	0	18,552	1.917	0.339	20,492	1.845	16,076
D0218244 SPC	2/19/00	6:48a	0	18,693	1.92	0.338	20,562	1.844	16,144
D0218245 SPC	2/19/00	6:53a	0	18,683	1.917	0.337	20,609	1.839	16,211
D0218246 SPC	2/19/00	6:58a	0.001	18,814	1.922	0.337	20,667	1.847	16,309
D0218247 SPC	2/19/00	7:02a	0	18,894	1.925	0.337	20,731	1.842	16,377
D0218248 SPC	2/19/00	7:07a	0	18,897	1.925	0.337	20,758	1.833	16,400
D0218249 SPC	2/19/00	7:11a	0	18,961	1.926	0.337	20,802	1.846	16,425
D0218250 SPC	2/19/00	7:16a	0	19,040	1.929	0.337	20,858	1.839	16,508
D0218251 SPC	2/19/00	7:20a	0	19,163	1.933	0.337	20,913	1.84	16,580
D0218252 SPC	2/19/00	7:25a	0.001	19,166	1.94	0.337	20,947	1.835	16,609
D0218253 SPC	2/19/00	7:29a	0.001	19,056	1.941	0.337	20,944	1.848	16,642
D0218254 SPC	2/19/00	7:34a	0	19,116	1.933	0.337	20,951	1.84	16,630
D0218255 SPC	2/19/00	7:38a	0	19,167	1.939	0.337	21,034	1.845	16,712
D0218256 SPC	2/19/00	7:43a	0	19,327	1.94	0.337	21,040	1.841	16,701
D0218257 SPC	2/19/00	7:47a	0	19,331	1.953	0.337	21,103	1.844	16,768
D0218258 SPC	2/19/00	7:52a	0	19,384	1.946	0.336	21,140	1.837	16,843
D0218259 SPC	2/19/00	7:56a	0	19,353	1.942	0.336	21,152	1.832	16,853
D0218260 SPC	2/19/00	8:01a	0	19,445	1.944	0.336	21,157	1.828	16,907
D0218261 SPC	2/19/00	8:06a	0	19,451	1.982	0.336	21,225	1.84	16,947
D0218262 SPC	2/19/00	8:10a	0	19,552	1.974	0.336	21,335	1.864	17,034
D0218263 SPC	2/19/00	8:15a	0	19,608	1.98	0.336	21,287	1.861	16,956
D0218264 SPC	2/19/00	8:19a	0	19,576	1.958	0.336	21,325	1.864	17,091
D0218265 SPC	2/19/00	8:24a	0	19,562	1.951	0.336	21,325	1.878	17,080
D0218266 SPC	2/19/00	8:28a	0	19,741	1.952	0.336	21,397	1.89	17,209
D0218267 SPC	2/19/00	8:33a	0	19,796	1.946	0.336	21,414	1.866	17,172
D0218268 SPC	2/19/00	8:37a	0	19,808	1.943	0.336	21,416	1.862	17,219
D0218269 SPC	2/19/00	8:42a	0	19,697	1.94	0.336	21,413	1.859	17,250
D0218270 SPC	2/19/00	8:46a	0	19,783	1.941	0.336	21,483	1.862	17,274
D0218271 SPC	2/19/00	8:51a	0	19,859	1.938	0.336	21,527	1.861	17,375

C-17

C-17

Table C-2. (Continued)

Collection Data			Quantification Method Concentrations in ppm						
File	Date	Time	Olin Mercury Plant		Olin 2		Olin 3		
			sulfur hexafluoride	water	carbon monoxide	nitrous oxide	water	methane	Water
D0218272 SPC	2/19/00	8:55a	0	19,796	1.94	0.336	21,542	1.869	17,401
D0218273 SPC	2/19/00	9:00a	0	19,828	1.941	0.337	21,568	1.852	17,447
D0218274 SPC	2/19/00	9:05a	0	20,004	1.937	0.336	21,642	1.842	17,593
D0218275 SPC	2/19/00	9:09a	0	20,028	1.937	0.336	21,674	1.833	17,620
D0218276 SPC	2/19/00	9:14a	0	20,008	1.938	0.337	21,724	1.821	17,744
D0218277 SPC	2/19/00	9:18a	0	20,015	1.927	0.337	21,674	1.82	17687

Table C-3.

Data Collection			Olin Mercury Plant		Quantification Method Concentrations in ppm			Olin 3	
File	Date	Time	sulfur hexafluoride	water	carbon monoxide	nitrous oxide	water	methane	Water
D0219002 SPC	2/19/00	10:26a	0	21,206	1.922	0.333	22,564	1.791	18,870
D0219003 SPC	2/19/00	10:31a	0	21,661	1.927	0.33	22,868	1.8	19,147
D0219004 SPC	2/19/00	10:35a	0	21,580	1.922	0.331	22,814	1.795	19,165
D0219005 SPC	2/19/00	10:40a	0	21,769	1.921	0.329	22,888	1.789	19,224
D0219006 SPC	2/19/00	10:44a	0	21,620	1.92	0.331	22,803	1.79	19,127
D0219007 SPC	2/19/00	10:49a	0	21,457	1.917	0.332	22,685	1.789	19,059
D0219008 SPC	2/19/00	10:54a	0	21,457	1.917	0.331	22,738	1.785	19,130
D0219009 SPC	2/19/00	10:58a	0	21,920	1.917	0.33	22,938	1.787	19,366
D0219010 SPC	2/19/00	11:03a	0	21,709	1.917	0.33	22,951	1.789	19,389
D0219011 SPC	2/19/00	11:07a	0	21,847	1.92	0.33	22,968	1.79	19,386
D0219012 SPC	2/19/00	11:12a	0	21,703	1.922	0.331	22,878	1.784	19,276
D0219013 SPC	2/19/00	11:16a	0	21,380	1.918	0.333	22,684	1.789	19,104
D0219014 SPC	2/19/00	11:21a	0	21,775	1.919	0.331	22,860	1.781	19,250
D0219015 SPC	2/19/00	11:28a	0	21,913	1.924	0.33	22,997	1.782	19,401
D0219016 SPC	2/19/00	11:37a	0	21,890	1.921	0.33	22,980	1.785	19,387
D0219017 SPC	2/19/00	12:12p	0	22,296	1.932	0.329	23,261	1.797	19,778
D0219018 SPC	2/19/00	1:05p	0	22,677	1.926	0.327	23,520	1.866	20,151
D0219019 SPC	2/19/00	1:14p	0	22,844	1.928	0.326	23,642	1.868	20,272
D0219020 SPC	2/19/00	1:41p	0	22,368	1.934	0.327	23,297	1.838	19,837
D0219021 SPC	2/19/00	1:47p	0	22,753	1.935	0.326	23,528	1.919	20,061
D0219022 SPC	2/19/00	1:52p	0	22,525	1.935	0.326	23,374	1.885	19,912
D0219023 SPC	2/19/00	1:56p	0	22,937	1.941	0.324	23,660	1.862	20,182
D0219024 SPC	2/19/00	2:01p	0	22,618	1.944	0.325	23,432	1.844	19,938
D0219025 SPC	2/19/00	2:05p	0.001	22,584	1.944	0.324	23,378	1.874	19,784
D0219026 SPC	2/19/00	2:10p	0.002	22,423	1.94	0.325	23,280	1.875	19,723
D0219027 SPC	2/19/00	2:14p	0.002	22,272	1.94	0.326	23,172	1.881	19,570
D0219028 SPC	2/19/00	2:19p	0.002	22,062	1.941	0.327	23,102	1.889	19,509
D0219029 SPC	2/19/00	2:23p	0.005	22,293	1.953	0.325	23,168	1.944	19,488
D0219030 SPC	2/19/00	2:28p	0.002	22,251	1.949	0.325	23,193	1.969	19,540
D0219031 SPC	2/19/00	2:32p	0.001	22,416	1.954	0.324	23,304	1.889	19,663

C-19

Table C-3. (Continued)

Data Collection			Olin Mercury Plant			Quantification Method Concentrations in ppm		Olin 3	
File	Date	Time	sulfur hexafluoride	water	carbon monoxide	nitrous oxide	water	methane	Water
D0219032 SPC	2/19/00	2:37p	0	21,986	1.95	0.327	22,964	1.875	19,260
D0219033 SPC	2/19/00	2:41p	0	21,817	1.947	0.327	22,841	1.875	19,151
D0219034 SPC	2/19/00	2:46p	0	22,017	1.949	0.327	23,015	1.891	19,342
D0219035 SPC	2/19/00	2:50p	0	21,795	1.955	0.328	22,847	1.863	19,109
D0219036 SPC	2/19/00	2:55p	0	21,531	1.945	0.328	22,667	1.848	18,893
D0219037 SPC	2/19/00	3:00p	0	21,908	1.951	0.326	22,849	1.88	19,130
D0219038 SPC	2/19/00	3:04p	0	21,376	1.951	0.328	22,531	1.871	18,681
D0219039 SPC	2/19/00	3:09p	0	21,195	1.959	0.327	22,457	1.837	18,489
D0219040 SPC	2/19/00	3:13p	0	21,075	1.962	0.327	22,302	1.897	18,294
D0219041 SPC	2/19/00	3:18p	0	21,170	1.965	0.326	22,318	1.853	18,259
D0219042 SPC	2/19/00	3:22p	0	20,910	1.964	0.328	22,161	1.854	18,059
D0219043 SPC	2/19/00	3:27p	0	20,668	1.969	0.328	22,048	1.877	17,924
D0219044 SPC	2/19/00	3:31p	0	20,759	1.977	0.327	22,082	1.863	17,867
D0219045 SPC	2/19/00	3:36p	0	20,863	1.976	0.327	22,076	1.817	17,843
D0219046 SPC	2/19/00	3:40p	0	20,301	1.964	0.329	21,637	1.842	17,405
D0219047 SPC	2/19/00	3:45p	0	20,768	1.974	0.326	22,040	1.915	17,816
D0219048 SPC	2/19/00	3:49p	0	21,031	1.974	0.325	22,214	1.913	18,016
D0219049 SPC	2/19/00	3:54p	0	20,813	1.976	0.327	22,023	1.818	17,761
D0219050 SPC	2/19/00	3:58p	0	20,906	1.976	0.326	22,118	1.808	17,825
D0219051 SPC	2/19/00	4:03p	0	20,915	1.977	0.326	22,087	1.81	17,836
D0219052 SPC	2/19/00	4:07p	0	20,654	1.99	0.327	21,985	1.799	17,685
D0219053 SPC	2/19/00	4:12p	0	20,272	1.984	0.328	21,782	1.786	17,436
D0219054 SPC	2/19/00	4:17p	0	20,521	1.984	0.326	21,942	1.799	17,597
D0219055 SPC	2/19/00	4:21p	0	20,770	1.997	0.327	22,153	1.806	17,861
D0219056 SPC	2/19/00	4:26p	0	20,969	2.035	0.328	22,337	1.827	18,158
D0219057 SPC	2/19/00	4:30p	0	20,694	2.051	0.329	22,154	1.829	17,845
D0219058 SPC	2/19/00	4:35p	0	20,354	2.036	0.329	21,926	1.846	17,548
D0219059 SPC	2/19/00	4:39p	0	19,741	2.03	0.331	21,466	1.835	16,950
D0219060 SPC	2/19/00	4:44p	0	19,750	2.029	0.331	21,424	1.827	16,906
D0219061 SPC	2/19/00	4:48p	0	19,974	2.035	0.33	21,590	1.829	17,081

Table C-3. (Continued)

Data Collection			Quantification Method Concentrations in ppm						
			Olin Mercury Plant		Olin 2			Olin 3	
File	Date	Time	sulfur hexafluoride	water	carbon monoxide	nitrous oxide	water	methane	Water
D0219062 SPC	2/19/00	4:53p	0	20,120	2.047	0.33	21,646	1.831	17,196
D0219063 SPC	2/19/00	4:57p	0	19,622	2.054	0.331	21,397	1.84	16,824
D0219064 SPC	2/19/00	5:02p	0	19,194	2.076	0.333	21,000	1.847	16,296
D0219065 SPC	2/19/00	5:06p	0	18,344	2.067	0.335	20,326	1.86	15,412
D0219066 SPC	2/19/00	5:11p	0	17,703	2.071	0.336	19,814	1.859	14,775
D0219067 SPC	2/19/00	5:15p	0	17,363	2.227	0.339	19,449	1.869	14,400
D0219068 SPC	2/19/00	5:20p	0	17,084	2.056	0.336	19,059	1.867	14,116
D0219069 SPC	2/19/00	5:24p	0	17,111	2.095	0.336	18,887	1.865	14,028
D0219070 SPC	2/19/00	5:29p	0	16,869	2.068	0.336	18,387	1.87	13,818
D0219071 SPC	2/19/00	5:33p	0	16,070	2.054	0.338	17,589	1.868	13,070
D0219072 SPC	2/19/00	5:38p	0	15,709	2.055	0.339	17,138	1.878	12,630
D0219073 SPC	2/19/00	5:42p	0	15,108	2.042	0.339	16,325	1.873	11,993
D0219074 SPC	2/19/00	5:47p	0	14,752	2.05	0.34	15,841	1.882	11,748
D0219075 SPC	2/19/00	5:51p	0	14,328	2.051	0.341	15,344	1.88	11,252
D0219076 SPC	2/19/00	5:56p	0	13,938	2.056	0.342	15,003	1.885	10,916
D0219077 SPC	2/19/00	6:01p	0	13,595	2.063	0.342	14,707	1.889	10,656
D0219078 SPC	2/19/00	6:05p	0	13,135	2.074	0.342	14,172	1.894	10,149
D0219079 SPC	2/19/00	6:10p	0	12,463	2.043	0.342	13,189	1.893	9,552
D0219080 SPC	2/19/00	6:14p	0	12,137	2.031	0.342	12,907	1.892	9,307
D0219081 SPC	2/19/00	6:19p	0	12,344	2.04	0.342	12,996	1.891	9,386
D0219082 SPC	2/19/00	6:23p	0	12,497	2.055	0.342	13,228	1.896	9,562
D0219083 SPC	2/19/00	6:28p	0	12,473	2.069	0.342	13,268	1.9	9,594
D0219084 SPC	2/19/00	6:32p	0	12,549	2.067	0.343	13,223	1.909	9,615
D0219085 SPC	2/19/00	6:37p	0	12,535	2.062	0.343	13,215	1.912	9,602
D0219086 SPC	2/19/00	6:41p	0	12,359	2.061	0.343	13,154	1.912	9,538
D0219087 SPC	2/19/00	6:46p	0	12,335	2.063	0.344	13,031	1.916	9,430
D0219088 SPC	2/19/00	6:50p	0	12,018	2.075	0.347	12,871	1.918	9,286
D0219089 SPC	2/19/00	6:55p	0	11,996	2.071	0.347	12,720	1.924	9,190
D0219090 SPC	2/19/00	6:59p	0	11,697	2.079	0.347	12,518	1.92	8,976
D0219091 SPC	2/19/00	7:04p	0	11,733	2.077	0.347	12,460	1.922	8,900

C-21

Table C-3. (Continued)

Data Collection			Quantification Method Concentrations in ppm						
			Olin Mercury Plant		Olin 2			Olin 3	
File	Date	Time	sulfur hexafluoride	water	carbon monoxide	nitrous oxide	water	methane	Water
D0219092 SPC	2/19/00	7:08p	0	11,837	2.078	0.348	12,594	1.928	9,089
D0219093 SPC	2/19/00	7:13p	0	11,931	2.082	0.348	12,790	1.935	9,244
D0219094 SPC	2/19/00	7:18p	0	12,217	2.083	0.347	13,057	1.931	9,494
D0219095 SPC	2/19/00	7:22p	0	12,390	2.088	0.347	13,224	1.928	9,622
D0219096 SPC	2/19/00	7:27p	0	12,381	2.096	0.347	13,247	1.938	9,666
D0219097 SPC	2/19/00	7:31p	0	12,654	2.107	0.347	13,450	1.946	9,813
D0219098 SPC	2/19/00	7:36p	0	12,748	2.108	0.348	13,543	1.949	9,882
D0219099 SPC	2/19/00	7:40p	0.001	12,605	2.109	0.348	13,630	1.956	9,932
D0219100 SPC	2/19/00	7:45p	0.002	12,760	2.11	0.347	13,870	1.956	10,030
D0219101 SPC	2/19/00	7:49p	0.001	12,669	2.11	0.349	13,680	1.955	9,964
D0219102 SPC	2/19/00	7:54p	0.002	12,711	2.115	0.349	13,698	1.956	9,962
D0219103 SPC	2/19/00	7:58p	0.002	12,493	2.116	0.35	13,381	1.96	9,842
D0219104 SPC	2/19/00	8:03p	0.002	12,062	2.13	0.35	12,991	1.966	9,455
D0219105 SPC	2/19/00	8:07p	0.002	11,481	2.121	0.354	12,475	1.969	9,002
D0219106 SPC	2/19/00	8:12p	0.002	11,211	2.12	0.355	12,194	1.974	8,780
D0219107 SPC	2/19/00	8:17p	0.002	11,202	2.115	0.354	12,169	1.975	8,734
D0219108 SPC	2/19/00	8:21p	0.003	11,128	2.121	0.355	12,111	1.974	8,701
D0219109 SPC	2/19/00	8:26p	0.004	11,103	2.12	0.354	12,104	1.98	8,652
D0219110 SPC	2/19/00	8:30p	0.003	11,149	2.13	0.354	12,089	1.969	8,641
D0219111 SPC	2/19/00	8:35p	0.003	10,981	2.133	0.354	12,063	1.97	8,626
D0219112 SPC	2/19/00	8:39p	0.004	11,048	2.134	0.355	11,935	1.97	8,517
D0219113 SPC	2/19/00	8:44p	0.004	10,806	2.143	0.356	11,781	1.969	8,384
D0219114 SPC	2/19/00	8:48p	0.005	10,620	2.128	0.356	11,649	1.976	8,275
D0219115 SPC	2/19/00	8:53p	0.005	10,540	2.11	0.356	11,358	1.968	8,148
D0219116 SPC	2/19/00	8:57p	0.005	9,984	2.113	0.359	10,673	1.979	7,731
D0219117 SPC	2/19/00	9:02p	0.006	10,004	2.109	0.359	10,770	1.973	7,806
D0219118 SPC	2/19/00	9:07p	0.005	9,872	2.111	0.359	10,607	1.976	7,692
D0219119 SPC	2/19/00	9:11p	0.006	10,053	2.112	0.359	10,732	1.975	7,767
D0219120 SPC	2/19/00	9:16p	0.006	10,175	2.111	0.358	10,785	1.97	7,829
D0219121 SPC	2/19/00	9:20p	0.008	10,172	2.117	0.357	10,830	1.979	7,828

Table C-3. (Continued)

Data Collection			Quantification Method Concentrations in ppm						
			Olin Mercury Plant		Olin 2			Olin 3	
File	Date	Time	sulfur hexafluoride	water	carbon monoxide	nitrous oxide	water	methane	Water
D0219122 SPC	2/19/00	9:25p	0.008	9,848	2.119	0.358	10,534	1.977	7,584
D0219123 SPC	2/19/00	9:29p	0.007	9,346	2.115	0.359	10,176	1.972	7,252
D0219124 SPC	2/19/00	9:34p	0.007	9,340	2.118	0.36	10,197	1.983	7,322
D0219125 SPC	2/19/00	9:38p	0.008	9,374	2.12	0.36	10,153	1.98	7,232
D0219126 SPC	2/19/00	9:43p	0.01	8,939	2.123	0.361	9,819	1.984	6,864
D0219127 SPC	2/19/00	9:47p	0.009	8,893	2.126	0.361	9,738	1.977	6,782
D0219128 SPC	2/19/00	9:52p	0.009	8,798	2.128	0.361	9,666	1.978	6,661
D0219129 SPC	2/19/00	9:57p	0.011	8,861	2.13	0.361	9,752	1.984	6,800
D0219130 SPC	2/19/00	10:01p	0.009	8,939	2.136	0.361	9,774	1.983	6,813
D0219131 SPC	2/19/00	10:06p	0.011	8,882	2.137	0.362	9,705	1.987	6,767
D0219132 SPC	2/19/00	10:10p	0.011	8,922	2.135	0.361	9,747	1.979	6,787
D0219133 SPC	2/19/00	10:15p	0.009	8,924	2.139	0.362	9,727	1.984	6,749
D0219134 SPC	2/19/00	10:19p	0.011	8,853	2.135	0.363	9,714	1.985	6,739
D0219135 SPC	2/19/00	10:24p	0.01	8,728	2.134	0.364	9,575	1.985	6,593
D0219136 SPC	2/19/00	10:28p	0.012	8,573	2.136	0.364	9,547	1.986	6,566
D0219137 SPC	2/19/00	10:33p	0.009	8,429	2.137	0.365	9,430	1.991	6,429
D0219138 SPC	2/19/00	10:37p	0.011	8,495	2.136	0.364	9,463	1.99	6,486
D0219139 SPC	2/19/00	10:42p	0.01	8,539	2.138	0.364	9,406	1.987	6,409
D0219140 SPC	2/19/00	10:47p	0.013	8,328	2.14	0.364	9,332	1.993	6,333
D0219141 SPC	2/19/00	10:51p	0.014	8,418	2.139	0.364	9,343	1.99	6,322
D0219142 SPC	2/19/00	10:56p	0.016	8,416	2.143	0.363	9,363	1.989	6,348
D0219143 SPC	2/19/00	11:00p	0.017	8,486	2.14	0.362	9,399	1.985	6,385
D0219144 SPC	2/19/00	11:05p	0.016	8,319	2.157	0.363	9,389	1.987	6,372
D0219145 SPC	2/19/00	11:09p	0.017	8,408	2.15	0.363	9,410	1.987	6,351
D0219146 SPC	2/19/00	11:14p	0.017	8,478	2.15	0.364	9,417	1.994	6,389
D0219147 SPC	2/19/00	11:18p	0.016	8,430	2.147	0.364	9,385	1.993	6,377
D0219148 SPC	2/19/00	11:23p	0.016	8,314	2.151	0.365	9,293	1.996	6,226
D0219149 SPC	2/19/00	11:27p	0.017	8,085	2.167	0.365	9,264	1.996	6,213
D0219150 SPC	2/19/00	11:32p	0.017	7,891	2.155	0.365	9,184	1.996	6,157
D0219151 SPC	2/19/00	11:37p	0.018	8,199	2.156	0.365	9,160	1.991	6,105

Table C-3. (Continued)

Data Collection			Quantification Method Concentrations in ppm						
			Olin Mercury Plant		Olin 2			Olin 3	
File	Date	Time	sulfur hexafluoride	water	carbon monoxide	nitrous oxide	water	methane	Water
D0219152 SPC	2/19/00	11:41p	0.02	7,888	2.151	0.365	9,099	1.99	6,037
D0219153 SPC	2/19/00	11:46p	0.019	8,254	2.155	0.365	9,240	2	6,211
D0219154 SPC	2/19/00	11:50p	0.019	8,034	2.153	0.366	9,156	1.996	6,108
D0219155 SPC	2/19/00	11:55p	0.024	8,053	2.151	0.365	9,165	1.994	6,125
D0219156 SPC	2/19/00	11:59p	0.023	8,107	2.155	0.366	9,130	2.005	6,093
D0219157 SPC	2/20/00	12:04a	0.021	8,029	2.155	0.365	9,126	1.995	6,073
D0219158 SPC	2/20/00	12:08a	0.021	8,002	2.155	0.365	9,087	2.001	6,015
D0219159 SPC	2/20/00	12:13a	0.021	7,917	2.159	0.366	9,009	1.995	5,920
D0219160 SPC	2/20/00	12:17a	0.022	8,023	2.162	0.366	9,052	2	5,975
D0219161 SPC	2/20/00	12:22a	0.022	7,884	2.159	0.366	9,004	1.997	5,956
D0219162 SPC	2/20/00	12:27a	0.022	7,869	2.163	0.366	9,018	2.005	5,936
D0219163 SPC	2/20/00	12:31a	0.02	7,903	2.159	0.366	9,032	2	5,987
D0219164 SPC	2/20/00	12:36a	0.021	7,886	2.163	0.367	9,041	2.006	5,990
D0219165 SPC	2/20/00	12:40a	0.023	7,993	2.164	0.366	9,055	2.004	5,995
D0219166 SPC	2/20/00	12:45a	0.025	7,996	2.163	0.366	9,092	1.998	6,019
D0219167 SPC	2/20/00	12:49a	0.024	8,030	2.162	0.366	9,076	1.994	6,032
D0219168 SPC	2/20/00	12:54a	0.024	7,916	2.182	0.366	9,074	1.994	6,001
D0219169 SPC	2/20/00	12:58a	0.023	7,955	2.165	0.366	9,038	2.003	5,978
D0219170 SPC	2/20/00	1:03a	0.023	7,908	2.163	0.366	9,013	2.001	5,952
D0219171 SPC	2/20/00	1:08a	0.025	7,840	2.165	0.367	9,020	2.004	5,931
D0219172 SPC	2/20/00	1:12a	0.027	7,873	2.163	0.366	9,016	2	5,967
D0219173 SPC	2/20/00	1:17a	0.025	7,911	2.163	0.367	8,980	2.002	5,902
D0219174 SPC	2/20/00	1:21a	0.022	7,798	2.165	0.367	8,951	2.008	5,835
D0219175 SPC	2/20/00	1:26a	0.023	7,759	2.164	0.367	8,948	2.004	5,827
D0219176 SPC	2/20/00	1:30a	0.024	7,939	2.163	0.367	8,965	1.998	5,879
D0219177 SPC	2/20/00	1:35a	0.026	7,728	2.166	0.367	8,958	2.001	5,882
D0219178 SPC	2/20/00	1:39a	0.023	7,721	2.165	0.367	8,898	2.006	5,775
D0219179 SPC	2/20/00	1:44a	0.026	7,844	2.164	0.367	8,935	1.995	5,849
D0219180 SPC	2/20/00	1:49a	0.027	7,711	2.168	0.367	8,943	2.009	5,881
D0219181 SPC	2/20/00	1:53a	0.025	7,726	2.163	0.367	8,906	2.004	5,806

Table C-3. (Continued)

Data Collection			Quantification Method Concentrations in ppm						
			Olin Mercury Plant		Olin 2			Olin 3	
File	Date	Time	sulfur hexafluoride	water	carbon monoxide	nitrous oxide	water	methane	Water
D0219182 SPC	2/20/00	1:58a	0.025	7,697	2.164	0.367	8,919	2.003	5,821
D0219183 SPC	2/20/00	2:02a	0.025	7,757	2.197	0.368	8,895	2.009	5,834
D0219184 SPC	2/20/00	2:07a	0.026	7,792	2.248	0.368	8,908	2.008	5,800
D0219185 SPC	2/20/00	2:11a	0.026	7,736	2.256	0.368	8,897	2.003	5,768
D0219186 SPC	2/20/00	2:16a	0.033	7,763	2.168	0.367	8,906	2.006	5,834
D0219187 SPC	2/20/00	2:20a	0.028	7,635	2.162	0.367	8,839	1.996	5,745
D0219188 SPC	2/20/00	2:25a	0.027	7,691	2.16	0.367	8,834	2.003	5,728
D0219189 SPC	2/20/00	2:30a	0.026	7,593	2.16	0.368	8,793	1.999	5,703
D0219190 SPC	2/20/00	2:34a	0.027	7,655	2.168	0.368	8,834	2.012	5,752
D0219191 SPC	2/20/00	2:39a	0.028	7,686	2.166	0.368	8,819	2.005	5,704
D0219192 SPC	2/20/00	2:43a	0.028	7,639	2.171	0.368	8,830	2.006	5,697
D0219193 SPC	2/20/00	2:48a	0.029	7,639	2.172	0.369	8,810	2.01	5,709
D0219194 SPC	2/20/00	2:52a	0.033	7,624	2.166	0.368	8,810	2.004	5,675
D0219195 SPC	2/20/00	2:57a	0.032	7,575	2.167	0.369	8,808	2.01	5,717
D0219196 SPC	2/20/00	3:02a	0.029	7,608	2.17	0.369	8,798	2.021	5,706
D0219197 SPC	2/20/00	3:06a	0.027	7,643	2.166	0.368	8,781	2.01	5,691
D0219198 SPC	2/20/00	3:11a	0.026	7,519	2.171	0.368	8,752	2.002	5,647
D0219199 SPC	2/20/00	3:15a	0.026	7,569	2.174	0.368	8,752	2.004	5,649
D0219200 SPC	2/20/00	3:20a	0.027	7,529	2.178	0.369	8,768	2.019	5,650
D0219201 SPC	2/20/00	3:24a	0.03	7,499	2.169	0.369	8,747	2.008	5,645
D0219202 SPC	2/20/00	3:29a	0.032	7,583	2.171	0.369	8,749	2.013	5,642
D0219203 SPC	2/20/00	3:34a	0.032	7,573	2.17	0.37	8,728	2.011	5,610
D0219204 SPC	2/20/00	3:38a	0.029	7,505	2.172	0.369	8,720	2.017	5,600
D0219205 SPC	2/20/00	3:43a	0.036	7,501	2.173	0.369	8,729	2.014	5,605
D0219206 SPC	2/20/00	3:47a	0.033	7,605	2.175	0.369	8,742	2.014	5,630
D0219207 SPC	2/20/00	3:52a	0.026	7,488	2.174	0.369	8,713	2.017	5,576
D0219208 SPC	2/20/00	3:56a	0.031	7,507	2.178	0.369	8,723	2.021	5,600
D0219209 SPC	2/20/00	4:01a	0.037	7,460	2.177	0.368	8,714	2.018	5,593
D0219210 SPC	2/20/00	4:06a	0.034	7,515	2.18	0.369	8,720	2.019	5,622
D0219211 SPC	2/20/00	4:10a	0.033	7,525	2.181	0.369	8,688	2.025	5,586

Table C-3. (Continued)

Data Collection			Quantification Method Concentrations in ppm						
			Olin Mercury Plant		Olin 2		Olin 3		
File	Date	Time	sulfur hexafluoride	water	carbon monoxide	nitrous oxide	water	methane	Water
D0219212 SPC	2/20/00	4:15a	0.035	7,494	2.181	0.37	8,692	2.022	5,574
D0219213 SPC	2/20/00	4:19a	0.032	7,445	2.181	0.37	8,664	2.019	5,535
D0219214 SPC	2/20/00	4:24a	0.034	7,424	2.181	0.37	8,662	2.015	5,556
D0219215 SPC	2/20/00	4:28a	0.029	7,424	2.182	0.37	8,646	2.016	5,520
D0219216 SPC	2/20/00	4:33a	0.03	7,420	2.179	0.37	8,657	2.015	5,537
D0219217 SPC	2/20/00	4:37a	0.03	7,480	2.176	0.37	8,651	2.022	5,512
D0219218 SPC	2/20/00	4:42a	0.03	7,372	2.177	0.37	8,627	2.016	5,516
D0219219 SPC	2/20/00	4:47a	0.031	7,458	2.179	0.37	8,664	2.017	5,547
D0219220 SPC	2/20/00	4:51a	0.03	7,440	2.176	0.37	8,628	2.012	5,519
D0219221 SPC	2/20/00	4:56a	0.03	7,421	2.177	0.371	8,610	2.014	5,470
D0219222 SPC	2/20/00	5:00a	0.03	7,444	2.178	0.37	8,606	2.014	5,480
D0219223 SPC	2/20/00	5:05a	0.033	7,314	2.181	0.37	8,612	2.02	5,472
D0219224 SPC	2/20/00	5:09a	0.042	7,347	2.181	0.37	8,630	2.017	5,502
D0219225 SPC	2/20/00	5:14a	0.044	7,281	2.179	0.37	8,609	2.015	5,461
D0219226 SPC	2/20/00	5:18a	0.042	7,335	2.181	0.371	8,580	2.014	5,425
D0219227 SPC	2/20/00	5:23a	0.029	7,305	2.179	0.372	8,560	2.03	5,395
D0219228 SPC	2/20/00	5:28a	0.029	7,341	2.193	0.371	8,578	2.022	5,456
D0219229 SPC	2/20/00	5:32a	0.031	7,289	2.185	0.371	8,534	2.023	5,411
D0219230 SPC	2/20/00	5:37a	0.031	7,289	2.186	0.371	8,542	2.022	5,378
D0219231 SPC	2/20/00	5:41a	0.032	7,280	2.178	0.371	8,513	2.02	5,376
D0219232 SPC	2/20/00	5:46a	0.03	7,247	2.178	0.372	8,499	2.019	5,339
D0219233 SPC	2/20/00	5:50a	0.033	7,178	2.175	0.372	8,466	2.02	5,314
D0219234 SPC	2/20/00	5:55a	0.032	7,166	2.178	0.372	8,464	2.023	5,320
D0219235 SPC	2/20/00	6:00a	0.034	7,242	2.177	0.372	8,474	2.023	5,340
D0219236 SPC	2/20/00	6:04a	0.036	7,170	2.181	0.372	8,472	2.022	5,314
D0219237 SPC	2/20/00	6:09a	0.036	7,216	2.184	0.372	8,465	2.022	5,307
D0219238 SPC	2/20/00	6:13a	0.031	7,154	2.196	0.373	8,439	2.024	5,288
D0219239 SPC	2/20/00	6:18a	0.033	7,140	2.182	0.374	8,424	2.017	5,289
D0219240 SPC	2/20/00	6:22a	0.032	7,198	2.179	0.373	8,399	2.021	5,265
D0219241 SPC	2/20/00	6:27a	0.032	7,149	2.184	0.374	8,406	2.022	5,268

C-26

C-26

Table C-3. (Continued)

Data Collection			Quantification Method Concentrations in ppm						
			Olin Mercury Plant		Olin 2		Olin 3		
File	Date	Time	sulfur hexafluoride	water	carbon monoxide	nitrous oxide	water	methane	Water
D0219242 SPC	2/20/00	6:32a	0.034	7,177	2.186	0.373	8,398	2.021	5,271
D0219243 SPC	2/20/00	6:36a	0.033	7,135	2.184	0.374	8,373	2.021	5,239
D0219244 SPC	2/20/00	6:41a	0.032	7,185	2.185	0.374	8,409	2.027	5,290
D0219245 SPC	2/20/00	6:45a	0.033	7,150	2.18	0.374	8,391	2.021	5,204
D0219246 SPC	2/20/00	6:50a	0.035	7,201	2.18	0.373	8,433	2.027	5,291
D0219247 SPC	2/20/00	6:54a	0.034	7,177	2.218	0.374	8,423	2.029	5,275
D0219248 SPC	2/20/00	6:59a	0.032	7,117	2.184	0.373	8,385	2.026	5,236
D0219249 SPC	2/20/00	7:04a	0.036	7,120	2.189	0.374	8,398	2.03	5,249
D0219250 SPC	2/20/00	7:08a	0.037	7,132	2.191	0.373	8,402	2.034	5,275
D0219251 SPC	2/20/00	7:13a	0.032	7,084	2.191	0.373	8,361	2.033	5,238
D0219252 SPC	2/20/00	7:17a	0.034	7,113	2.209	0.373	8,397	2.026	5,250
D0219253 SPC	2/20/00	7:22a	0.035	7,090	2.205	0.374	8,399	2.031	5,246
D0219254 SPC	2/20/00	7:26a	0.034	7,067	2.207	0.374	8,357	2.031	5,188
D0219255 SPC	2/20/00	7:31a	0.033	7,043	2.202	0.373	8,328	2.029	5,187
D0219256 SPC	2/20/00	7:36a	0.034	7,029	2.215	0.373	8,350	2.028	5,211
D0219257 SPC	2/20/00	7:40a	0.032	7,067	2.226	0.374	8,349	2.035	5,201
D0219258 SPC	2/20/00	7:45a	0.035	7,070	2.229	0.375	8,332	2.039	5,183
D0219259 SPC	2/20/00	7:49a	0.034	7,099	2.221	0.374	8,330	2.034	5,164
D0219260 SPC	2/20/00	7:54a	0.04	7,148	2.219	0.373	8,361	2.034	5,186
D0219261 SPC	2/20/00	7:58a	0.044	7,190	2.229	0.373	8,433	2.039	5,284
D0219262 SPC	2/20/00	8:03a	0.045	7,178	2.228	0.373	8,444	2.039	5,294
D0219263 SPC	2/20/00	8:08a	0.045	7,273	2.245	0.372	8,505	2.047	5,369
D0219264 SPC	2/20/00	8:12a	0.044	7,311	2.243	0.371	8,515	2.049	5,413
D0219265 SPC	2/20/00	8:17a	0.039	7,320	2.252	0.372	8,569	2.056	5,415
D0219266 SPC	2/20/00	8:21a	0.042	7,375	2.245	0.371	8,629	2.081	5,509
D0219267 SPC	2/20/00	8:26a	0.045	7,397	2.249	0.371	8,657	2.138	5,508
D0219268 SPC	2/20/00	8:30a	0.046	7,479	2.353	0.371	8,726	2.175	5,619
D0219269 SPC	2/20/00	8:35a	0.032	7,462	2.25	0.37	8,758	2.173	5,661
D0219270 SPC	2/20/00	8:40a	0.009	7,475	2.216	0.37	8,769	2.193	5,696
D0219271 SPC	2/20/00	8:44a	0.004	7,364	2.211	0.371	8,720	2.22	5,635

C-27

C-27

Table C-3. (Continued)

Data Collection			Quantification Method Concentrations in ppm						
			Olin Mercury Plant		Olin 2			Olin 3	
File	Date	Time	sulfur hexafluoride	water	carbon monoxide	nitrous oxide	water	methane	Water
D0219272 SPC	2/20/00	8:49a	0.002	7,385	2.211	0.371	8,742	2.231	5,624
D0219273 SPC	2/20/00	8:53a	0.001	7,308	2.205	0.371	8,723	2.19	5,617
D0219274 SPC	2/20/00	9:36a	0	7,099	2.167	0.375	8,476	2.029	5,261
D0219275 SPC	2/20/00	9:41a	0	7,184	2.173	0.375	8,566	2.035	5,331
D0219276 SPC	2/20/00	9:45a	0	7,186	2.17	0.374	8,526	2.035	5,297
D0219277 SPC	2/20/00	9:50a	0	7,005	2.167	0.374	8,483	2.039	5,247
D0219278 SPC	2/20/00	9:54a	0	7,005	2.16	0.372	8,432	2.032	5,195
D0219279 SPC	2/20/00	9:59a	0	7,099	2.158	0.371	8,485	2.036	5,301
D0219280 SPC	2/20/00	10:03a	0	7,152	2.202	0.371	8,506	2.037	5,307
D0219281 SPC	2/20/00	10:08a	0	7,119	2.157	0.369	8,514	2.047	5,309
D0219282 SPC	2/20/00	10:12a	0	6,976	2.147	0.367	8,431	2.039	5,187
D0219283 SPC	2/20/00	10:17a	0	6,957	2.146	0.367	8,427	2.045	5,195
D0219284 SPC	2/20/00	10:22a	0	7,099	2.144	0.366	8,494	2.04	5,299
D0219285 SPC	2/20/00	10:26a	0	7,067	2.148	0.366	8,463	2.04	5,208
D0219286 SPC	2/20/00	10:31a	0	7,086	2.157	0.368	8,470	2.048	5,223
D0219287 SPC	2/20/00	10:35a	0	6,972	2.158	0.368	8,451	2.053	5,206
D0219288 SPC	2/20/00	10:40a	0	7,076	2.149	0.367	8,439	2.05	5,206
D0219289 SPC	2/20/00	10:44a	0	6,969	2.143	0.367	8,340	2.05	5,079
D0219290 SPC	2/20/00	10:49a	0	6,887	2.137	0.365	8,369	2.043	5,129
D0219291 SPC	2/20/00	10:53a	0	6,926	2.135	0.365	8,323	2.04	5,097
D0219292 SPC	2/20/00	10:58a	0	6,825	2.135	0.366	8,339	2.041	5,112
D0219293 SPC	2/20/00	11:02a	0	7,060	2.132	0.366	8,408	2.041	5,173
D0219294 SPC	2/20/00	11:07a	0	7,027	2.132	0.365	8,423	2.034	5,172
D0219295 SPC	2/20/00	11:12a	0	6,772	2.125	0.364	8,240	2.033	4,954
D0219296 SPC	2/20/00	11:16a	0	6,737	2.12	0.364	8,144	2.029	4,892
D0219297 SPC	2/20/00	11:21a	0	6,788	2.127	0.365	8,215	2.037	4,960
D0219298 SPC	2/20/00	11:25a	0	6,760	2.125	0.364	8,209	2.031	4,912
D0219299 SPC	2/20/00	11:30a	0	6,534	2.128	0.366	8,132	2.043	4,828
D0219300 SPC	2/20/00	11:34a	0	6,793	2.126	0.365	8,188	2.039	4,871
D0219301 SPC	2/20/00	11:39a	0	6,669	2.119	0.364	8,123	2.033	4,821

Table C-3. (Continued)

Data Collection			Quantification Method Concentrations in ppm						
			Olin Mercury Plant		Olin 2			Olin 3	
File	Date	Time	sulfur hexafluoride	water	carbon monoxide	nitrous oxide	water	methane	Water
D0219302 SPC	2/20/00	11:43a	0	6,579	2.116	0.364	8,034	2.026	4,733
D0219303 SPC	2/20/00	11:48a	0	6,594	2.117	0.365	8,050	2.022	4,720
D0219304 SPC	2/20/00	11:52a	0	6,817	2.127	0.367	8,269	2.027	5,016
D0219305 SPC	2/20/00	11:57a	0	6,780	2.124	0.367	8,213	2.019	4,948
D0219306 SPC	2/20/00	12:02p	0	6,853	2.124	0.367	8,263	2.025	4,957
D0219307 SPC	2/20/00	12:06p	0	6,875	2.14	0.368	8,294	2.033	4,997
D0219308 SPC	2/20/00	12:11p	0	7,006	2.133	0.367	8,318	2.025	5,052
D0219309 SPC	2/20/00	12:15p	0	6,665	2.119	0.367	8,082	2.011	4,770
D0219310 SPC	2/20/00	12:30p	0	6,820	2.122	0.369	8,138	2.011	4,855
D0219311 SPC	2/20/00	12:35p	0	6,896	2.126	0.37	8,275	2.016	4,950
D0219312 SPC	2/20/00	12:40p	0	6,994	2.13	0.37	8,290	2.006	4,984
D0219313 SPC	2/20/00	12:44p	0	6,837	2.133	0.371	8,194	2.016	4,872
D0219314 SPC	2/20/00	12:49p	0	6,810	2.134	0.371	8,215	2.032	4,865
D0219315 SPC	2/20/00	12:53p	0	6,683	2.132	0.371	8,062	2.025	4,687
D0219316 SPC	2/20/00	12:58p	0	6,837	2.136	0.37	8,183	2.033	4,855
D0219317 SPC	2/20/00	1:02p	0	6,832	2.135	0.368	8,210	2.027	4,887
D0219318 SPC	2/20/00	1:07p	0	6,588	2.133	0.37	8,033	2.028	4,655
D0219319 SPC	2/20/00	1:11p	0	6,719	2.132	0.368	8,137	2.026	4,774
D0219320 SPC	2/20/00	1:16p	0	6,721	2.129	0.366	8,112	2.033	4,757
D0219321 SPC	2/20/00	1:20p	0	6,765	2.128	0.364	8,165	2.048	4,799
D0219322 SPC	2/20/00	1:25p	0	6,803	2.131	0.364	8,165	2.031	4,815
D0219323 SPC	2/20/00	1:29p	0	6,807	2.162	0.366	8,181	2.043	4,832
D0219324 SPC	2/20/00	1:34p	0	6,611	2.131	0.363	8,049	2.018	4,716
D0219325 SPC	2/20/00	1:38p	0	6,609	2.131	0.363	8,039	2.029	4,673
D0219326 SPC	2/20/00	1:43p	0	6,761	2.138	0.363	8,152	2.045	4,800
D0219327 SPC	2/20/00	2:32p	0	6,301	2.142	0.365	7,828	1.989	4,453
D0219328 SPC	2/20/00	2:36p	0	6,443	2.12	0.364	7,813	2.008	4386

Table C-4.

Collection Data			Olin Mercury Plant				Olin 2		Olin 3	
File	Date	Time	sulfur		carbon	nitrous oxide	water	methane	Water	
			hexafluoride	water	monoxide					
DO220002 SPC	2/20/00	2:59p	0.001	6,066	2.106	0.364	7,556	1.982	4,177	
DO220003 SPC	2/20/00	3:03p	0.001	6,132	2.105	0.363	7,606	1.989	4,178	
DO220004 SPC	2/20/00	3:08p	0.001	5,949	2.102	0.364	7,442	1.974	4,048	
DO220005 SPC	2/20/00	3:13p	0.001	5,949	2.103	0.364	7,479	1.998	4,090	
DO220006 SPC	2/20/00	3:17p	0.002	6,007	2.107	0.363	7,511	2.002	4,090	
DO220007 SPC	2/20/00	3:22p	0.002	6,122	2.109	0.362	7,560	1.987	4,134	
DO220008 SPC	2/20/00	3:26p	0.001	5,966	2.111	0.363	7,468	1.996	4,036	
DO220009 SPC	2/20/00	3:31p	0.002	6,027	2.11	0.363	7,526	1.99	4,083	
DO220010 SPC	2/20/00	3:35p	0.001	5,961	2.114	0.364	7,486	1.997	4,050	
DO220011 SPC	2/20/00	3:40p	0.002	5,976	2.123	0.363	7,525	1.996	4,095	
DO220012 SPC	2/20/00	3:44p	0.002	6,226	2.143	0.362	7,709	1.986	4,321	
DO220013 SPC	2/20/00	3:49p	0.001	6,276	2.142	0.363	7,797	1.995	4,403	
DO220014 SPC	2/20/00	3:53p	0.002	6,313	2.12	0.363	7,761	2.001	4,369	
DO220015 SPC	2/20/00	3:58p	0.002	6,368	2.114	0.362	7,757	1.997	4,396	
DO220016 SPC	2/20/00	4:02p	0.002	6,310	2.112	0.362	7,718	1.981	4,314	
DO220017 SPC	2/20/00	4:07p	0.002	6,234	2.117	0.363	7,649	1.993	4,278	
DO220018 SPC	2/20/00	4:11p	0.002	6,285	2.152	0.363	7,736	1.996	4,342	
DO220019 SPC	2/20/00	4:16p	0.002	6,360	2.122	0.362	7,775	1.997	4,391	
DO220020 SPC	2/20/00	4:21p	0.001	6,276	2.139	0.363	7,722	1.997	4,308	
DO220021 SPC	2/20/00	4:25p	0.001	6,381	2.127	0.363	7,780	1.984	4,361	
DO220022 SPC	2/20/00	4:30p	0.001	6,260	2.114	0.363	7,715	1.981	4,325	
DO220023 SPC	2/20/00	4:34p	0.002	6,386	2.12	0.363	7,729	2.005	4,332	
DO220024 SPC	2/20/00	4:39p	0.002	6,370	2.107	0.362	7,744	2.006	4,323	
DO220025 SPC	2/20/00	4:43p	0.001	6,271	2.101	0.363	7,695	1.986	4,304	
DO220026 SPC	2/20/00	4:48p	0.001	6,541	2.101	0.363	7,865	1.978	4,436	
DO220027 SPC	2/20/00	4:52p	0.001	6,474	2.114	0.363	7,884	1.98	4,506	
DO220028 SPC	2/20/00	4:57p	0.001	6,527	2.104	0.362	7,938	1.972	4,543	
DO220029 SPC	2/20/00	5:01p	0.001	6,528	2.104	0.361	7,904	1.979	4,505	
DO220030 SPC	2/20/00	5:06p	0.001	6,425	2.101	0.363	7,799	1.978	4,427	
DO220031 SPC	2/20/00	5:10p	0.002	6,422	2.101	0.362	7,842	1.995	4,482	

C-30

Table C-4. (Continued)

Collection Data			Olin Mercury Plant				Olin 2		Olin 3
File	Date	Time	sulfur hexafluoride	water	carbon monoxide	nitrous oxide	water	methane	Water
DO220032 SPC	2/20/00	5:15p	0.002	6,529	2.101	0.362	7,909	1.988	4,543
DO220033 SPC	2/20/00	5:19p	0.001	6,441	2.13	0.362	7,886	1.977	4,484
DO220034 SPC	2/20/00	5:24p	0.001	6,393	2.102	0.362	7,825	1.973	4,445
DO220035 SPC	2/20/00	5:29p	0.001	6,441	2.113	0.362	7,861	1.97	4,447
DO220036 SPC	2/20/00	5:33p	0.001	6,517	2.141	0.363	7,918	1.969	4,514
DO220037 SPC	2/20/00	5:38p	0.002	6,399	2.112	0.362	7,865	1.972	4,483
DO220038 SPC	2/20/00	5:42p	0.002	6,396	2.111	0.361	7,792	1.982	4,401
DO220039 SPC	2/20/00	5:47p	0.002	6,281	2.102	0.362	7,763	1.977	4,387
DO220040 SPC	2/20/00	5:51p	0.002	6,352	2.102	0.362	7,772	1.98	4,380
DO220041 SPC	2/20/00	5:56p	0.002	6,462	2.105	0.362	7,828	1.979	4,435
DO220042 SPC	2/20/00	6:00p	0.002	6,319	2.108	0.361	7,792	2.03	4,407
DO220043 SPC	2/20/00	6:05p	0.002	6,315	2.108	0.362	7,745	2.071	4,375
DO220044 SPC	2/20/00	6:09p	0.002	6,222	2.106	0.362	7,751	2.068	4,360
DO220045 SPC	2/20/00	6:14p	0.002	6,327	2.107	0.362	7,752	2.036	4,365
DO220046 SPC	2/20/00	6:18p	0.002	6,350	2.103	0.362	7,760	2.009	4,382
DO220047 SPC	2/20/00	6:23p	0.002	6,358	2.102	0.362	7,747	1.999	4,356
DO220048 SPC	2/20/00	6:28p	0.002	6,454	2.101	0.363	7,829	2.001	4,484
DO220049 SPC	2/20/00	6:32p	0.002	6,385	2.102	0.362	7,809	1.983	4,454
DO220050 SPC	2/20/00	6:37p	0.002	6,475	2.105	0.363	7,828	1.988	4,436
DO220051 SPC	2/20/00	6:41p	0.002	6,495	2.102	0.363	7,828	1.984	4,438
DO220052 SPC	2/20/00	6:46p	0.002	6,510	2.098	0.363	7,901	1.989	4,537
DO220053 SPC	2/20/00	6:50p	0.002	6,508	2.096	0.364	7,921	1.987	4,556
DO220054 SPC	2/20/00	6:55p	0.002	6,517	2.097	0.363	7,890	1.974	4,518
DO220055 SPC	2/20/00	6:59p	0.002	6,562	2.101	0.363	7,929	1.977	4,576
DO220056 SPC	2/20/00	7:04p	0.003	6,636	2.092	0.363	8,035	1.982	4,708
DO220057 SPC	2/20/00	7:08p	0.002	6,730	2.088	0.364	8,089	1.977	4,787
DO220058 SPC	2/20/00	7:13p	0.003	6,724	2.096	0.364	8,068	1.975	4,743
DO220059 SPC	2/20/00	7:17p	0.003	6,766	2.148	0.365	8,079	1.973	4,763
DO220060 SPC	2/20/00	7:22p	0.003	6,831	2.151	0.365	8,140	1.986	4,813
DO220061 SPC	2/20/00	7:26p	0.003	6,821	2.15	0.365	8,152	2.003	4,798

C-31

Table C-4. (Continued)

Collection Data			Quantification Method Concentrations in ppm						
			Olin Mercury Plant		Olin 2		Olin 3		
File	Date	Time	sulfur hexafluoride	water	carbon monoxide	nitrous oxide	water	methane	Water
DO220062 SPC	2/20/00	7:31p	0.003	6,784	2.119	0.366	8,132	2.003	4,845
DO220063 SPC	2/20/00	7:36p	0.003	6,776	2.141	0.366	8,125	2	4,786
DO220064 SPC	2/20/00	7:40p	0.003	7,095	2.161	0.367	8,344	2.017	5,051
DO220065 SPC	2/20/00	7:45p	0.003	7,199	2.137	0.367	8,413	2.045	5,191
DO220066 SPC	2/20/00	7:49p	0.004	7,204	2.145	0.367	8,383	2.11	5,127
DO220067 SPC	2/20/00	7:54p	0.004	7,148	2.155	0.367	8,399	2.253	5,118
DO220068 SPC	2/20/00	7:58p	0.004	7,290	2.174	0.367	8,437	2.321	5,193
DO220069 SPC	2/20/00	8:03p	0.005	7,244	2.329	0.369	8,472	2.301	5,197
DO220070 SPC	2/20/00	8:07p	0.005	7,243	2.198	0.368	8,468	2.307	5,197
DO220071 SPC	2/20/00	8:12p	0.006	7,176	2.156	0.368	8,434	2.314	5,153
DO220072 SPC	2/20/00	8:16p	0.007	7,206	2.195	0.368	8,433	2.295	5,185
DO220073 SPC	2/20/00	8:21p	0.007	7,131	2.233	0.369	8,456	2.282	5,184
DO220074 SPC	2/20/00	8:25p	0.007	7,186	2.212	0.369	8,488	2.253	5,204
DO220075 SPC	2/20/00	8:30p	0.007	7,284	2.25	0.37	8,487	2.232	5,215
DO220076 SPC	2/20/00	8:35p	0.008	7,206	2.283	0.37	8,552	2.295	5,273
DO220077 SPC	2/20/00	8:39p	0.008	7,553	2.229	0.37	8,611	2.322	5,370
DO220078 SPC	2/20/00	8:44p	0.008	7,457	2.229	0.37	8,593	2.185	5,352
DO220079 SPC	2/20/00	8:48p	0.008	7,357	2.262	0.371	8,577	2.107	5,307
DO220080 SPC	2/20/00	8:53p	0.009	7,350	2.297	0.37	8,628	2.157	5,405
DO220081 SPC	2/20/00	8:57p	0.009	7,511	2.228	0.37	8,665	2.125	5,396
DO220082 SPC	2/20/00	9:02p	0.01	7,205	2.267	0.371	8,616	2.122	5,373
DO220083 SPC	2/20/00	9:06p	0.009	7,423	2.269	0.371	8,632	2.141	5,339
DO220084 SPC	2/20/00	9:11p	0.008	7,621	2.257	0.371	8,746	2.119	5,500
DO220085 SPC	2/20/00	9:15p	0.009	7,616	2.256	0.371	8,740	2.097	5,469
DO220086 SPC	2/20/00	9:20p	0.011	7,535	2.268	0.372	8,685	2.119	5,400
DO220087 SPC	2/20/00	9:25p	0.011	7,544	2.277	0.372	8,671	2.11	5,408
DO220088 SPC	2/20/00	9:29p	0.011	7,481	2.282	0.372	8,638	2.111	5,363
DO220089 SPC	2/20/00	9:34p	0.012	7,503	2.287	0.372	8,639	2.13	5,367
DO220090 SPC	2/20/00	9:38p	0.012	7,524	2.372	0.372	8,652	2.169	5,381
DO220091 SPC	2/20/00	9:43p	0.012	7,532	2.279	0.372	8,741	2.172	5,529

C-32

Table C-4. (Continued)

Collection Data			Quantification Method Concentrations in ppm						
			Olin Mercury Plant		Olin 2		Olin 3		
File	Date	Time	sulfur hexafluoride	water	carbon monoxide	nitrous oxide	water	methane	Water
DO220092 SPC	2/20/00	9:47p	0.012	7,557	2.287	0.372	8,677	2.312	5,474
DO220093 SPC	2/20/00	9:52p	0.011	7,435	2.437	0.373	8,634	2.422	5,355
DO220094 SPC	2/20/00	9:57p	0.012	7,415	2.631	0.375	8,627	2.429	5,330
DO220095 SPC	2/20/00	10:01p	0.012	7,504	2.399	0.373	8,644	2.388	5,387
DO220096 SPC	2/20/00	10:06p	0.013	7,350	2.332	0.373	8,589	2.329	5,385
DO220097 SPC	2/20/00	10:10p	0.012	7,444	2.347	0.374	8,624	2.321	5,423
DO220098 SPC	2/20/00	10:15p	0.013	7,409	2.358	0.374	8,593	2.39	5,402
DO220099 SPC	2/20/00	10:19p	0.015	7,405	2.452	0.375	8,597	2.484	5,387
DO220100 SPC	2/20/00	10:24p	0.016	7,419	2.384	0.374	8,580	2.316	5,384
DO220101 SPC	2/20/00	10:29p	0.016	7,479	2.333	0.374	8,671	2.32	5,453
DO220102 SPC	2/20/00	10:33p	0.015	7,524	2.305	0.374	8,725	2.286	5,594
DO220103 SPC	2/20/00	10:38p	0.015	7,507	2.299	0.374	8,724	2.24	5,593
DO220104 SPC	2/20/00	10:42p	0.014	7,422	2.313	0.375	8,625	2.209	5,432
DO220105 SPC	2/20/00	10:47p	0.014	7,350	2.338	0.375	8,530	2.223	5,338
DO220106 SPC	2/20/00	10:51p	0.014	7,215	2.35	0.375	8,473	2.253	5,273
DO220107 SPC	2/20/00	10:56p	0.014	7,227	2.346	0.376	8,432	2.197	5,212
DO220108 SPC	2/20/00	11:01p	0.016	7,206	2.463	0.377	8,461	2.338	5,239
DO220109 SPC	2/20/00	11:05p	0.016	7,264	2.428	0.376	8,446	2.234	5,218
DO220110 SPC	2/20/00	11:10p	0.016	7,115	2.478	0.376	8,395	2.427	5,147
DO220111 SPC	2/20/00	11:14p	0.017	7,083	2.814	0.378	8,419	2.539	5,145
DO220112 SPC	2/20/00	11:19p	0.017	6,961	2.56	0.378	8,297	2.387	5,076
DO220113 SPC	2/20/00	11:23p	0.016	6,959	2.514	0.378	8,266	2.408	5,033
DO220114 SPC	2/20/00	11:28p	0.016	7,002	2.442	0.377	8,279	2.638	5,053
DO220115 SPC	2/20/00	11:33p	0.017	6,859	2.396	0.376	8,133	2.583	4,893
DO220116 SPC	2/20/00	11:37p	0.017	6,767	2.362	0.375	8,082	2.546	4,829
DO220117 SPC	2/20/00	11:42p	0.016	6,595	2.327	0.374	7,996	2.507	4,696
DO220118 SPC	2/20/00	11:46p	0.018	6,764	2.373	0.375	8,073	2.501	4,795
DO220119 SPC	2/20/00	11:51p	0.021	7,082	2.335	0.374	8,312	2.438	5,096
DO220120 SPC	2/20/00	11:55p	0.02	7,301	2.318	0.374	8,486	2.442	5,317
DO220121 SPC	2/21/00	12:00a	0.018	7,463	2.309	0.375	8,558	2.498	5,360

Table C-4. (Continued)

Collection Data			Quantification Method Concentrations in ppm						
			Olin Mercury Plant		Olin 2		Olin 3		
File	Date	Time	sulfur hexafluoride	water	carbon monoxide	nitrous oxide	water	methane	Water
DO220122 SPC	2/21/00	12:05a	0.017	7,238	2.32	0.375	8,472	2.509	5,289
DO220123 SPC	2/21/00	12:09a	0.017	7,237	2.317	0.376	8,496	2.544	5,330
DO220124 SPC	2/21/00	12:14a	0.018	7,263	2.313	0.376	8,517	2.412	5,315
DO220125 SPC	2/21/00	12:18a	0.018	7,238	2.311	0.375	8,422	2.318	5,260
DO220126 SPC	2/21/00	12:23a	0.019	7,065	2.342	0.376	8,314	2.346	5,082
DO220127 SPC	2/21/00	12:27a	0.02	6,986	2.332	0.376	8,234	2.395	5,013
DO220128 SPC	2/21/00	12:32a	0.023	7,015	2.33	0.376	8,224	2.4	4,982
DO220129 SPC	2/21/00	12:37a	0.022	7,047	2.337	0.376	8,281	2.439	5,087
DO220130 SPC	2/21/00	12:41a	0.024	7,127	2.348	0.375	8,369	2.435	5,167
DO220131 SPC	2/21/00	12:46a	0.018	7,112	2.34	0.377	8,358	2.439	5,168
DO220132 SPC	2/21/00	12:50a	0.019	7,123	2.338	0.376	8,308	2.452	5,102
DO220133 SPC	2/21/00	12:55a	0.02	7,067	2.339	0.376	8,288	2.447	5,080
DO220134 SPC	2/21/00	1:00a	0.019	7,009	2.378	0.377	8,229	2.456	5,044
DO220135 SPC	2/21/00	1:04a	0.017	6,966	2.37	0.376	8,198	2.464	4,937
DO220136 SPC	2/21/00	1:09a	0.018	6,955	2.342	0.377	8,226	2.494	5,049
DO220137 SPC	2/21/00	1:13a	0.022	6,911	2.338	0.376	8,147	2.491	4,937
DO220138 SPC	2/21/00	1:18a	0.021	6,830	2.341	0.377	8,134	2.485	4,912
DO220139 SPC	2/21/00	1:22a	0.021	6,943	2.351	0.377	8,159	2.473	4,968
DO220140 SPC	2/21/00	1:27a	0.021	6,783	2.345	0.378	8,060	2.488	4,840
DO220141 SPC	2/21/00	1:32a	0.018	6,755	2.344	0.378	8,014	2.488	4,784
DO220142 SPC	2/21/00	1:36a	0.019	6,624	2.331	0.378	7,936	2.651	4,719
DO220143 SPC	2/21/00	1:41a	0.022	6,652	2.32	0.377	7,928	2.889	4,695
DO220144 SPC	2/21/00	1:45a	0.018	6,542	2.323	0.378	7,883	2.691	4,645
DO220145 SPC	2/21/00	1:50a	0.021	6,558	2.327	0.377	7,908	2.677	4,679
DO220146 SPC	2/21/00	1:55a	0.022	6,586	2.324	0.378	7,866	2.694	4,603
DO220147 SPC	2/21/00	1:59a	0.021	6,548	2.303	0.378	7,839	2.722	4,601
DO220148 SPC	2/21/00	2:04a	0.023	6,496	2.291	0.378	7,838	2.688	4,607
DO220149 SPC	2/21/00	2:08a	0.022	6,698	2.308	0.378	7,931	2.536	4,699
DO220150 SPC	2/21/00	2:13a	0.025	6,667	2.32	0.379	7,974	2.54	4,751
DO220151 SPC	2/21/00	2:17a	0.027	6,800	2.337	0.38	8,045	2.524	4,826

Table C-4. (Continued)

Collection Data			Quantification Method Concentrations in ppm						
			Olin Mercury Plant		Olin 2			Olin 3	
File	Date	Time	sulfur hexafluoride	water	carbon monoxide	nitrous oxide	water	methane	Water
DO220152 SPC	2/21/00	2:22a	0.027	6,841	2.358	0.381	8,081	2.493	4,842
DO220153 SPC	2/21/00	2:27a	0.028	6,769	2.363	0.382	7,993	2.472	4,751
DO220154 SPC	2/21/00	2:31a	0.026	6,689	2.37	0.381	7,972	2.464	4,721
DO220155 SPC	2/21/00	2:36a	0.026	6,718	2.402	0.38	8,051	2.445	4,763
DO220156 SPC	2/21/00	2:40a	0.024	6,618	2.414	0.379	7,940	2.466	4,636
DO220157 SPC	2/21/00	2:45a	0.026	6,705	2.434	0.379	8,033	2.459	4,752
DO220158 SPC	2/21/00	2:49a	0.026	6,835	2.463	0.379	8,090	2.492	4,795
DO220159 SPC	2/21/00	2:54a	0.024	6,796	2.487	0.378	8,145	2.529	4,875
DO220160 SPC	2/21/00	2:59a	0.024	6,880	2.473	0.378	8,173	2.759	4,932
DO220161 SPC	2/21/00	3:03a	0.025	6,868	2.482	0.378	8,173	3.116	4,932
DO220162 SPC	2/21/00	3:08a	0.025	6,923	2.506	0.378	8,218	3.174	4,965
DO220163 SPC	2/21/00	3:12a	0.026	6,871	2.494	0.377	8,215	2.923	4,958
DO220164 SPC	2/21/00	3:17a	0.029	7,035	2.592	0.377	8,328	2.779	5,050
DO220165 SPC	2/21/00	3:22a	0.03	7,121	2.513	0.376	8,400	2.668	5,136
DO220166 SPC	2/21/00	3:26a	0.031	7,039	2.496	0.376	8,298	2.585	5,079
DO220167 SPC	2/21/00	3:31a	0.03	6,850	2.465	0.377	8,185	2.487	4,915
DO220168 SPC	2/21/00	3:35a	0.029	6,813	2.464	0.377	8,135	2.451	4,856
DO220169 SPC	2/21/00	3:40a	0.03	6,820	2.504	0.378	8,109	2.432	4,794
DO220170 SPC	2/21/00	3:44a	0.027	6,715	2.556	0.379	8,044	2.454	4,774
DO220171 SPC	2/21/00	3:49a	0.029	6,639	2.538	0.379	7,980	2.508	4,677
DO220172 SPC	2/21/00	3:54a	0.027	6,683	2.482	0.378	8,024	2.553	4,733
DO220173 SPC	2/21/00	3:58a	0.029	6,749	2.496	0.378	8,079	2.62	4,801
DO220174 SPC	2/21/00	4:03a	0.026	6,582	2.467	0.379	7,976	2.608	4,712
DO220175 SPC	2/21/00	4:07a	0.028	6,629	2.438	0.378	7,993	2.532	4,694
DO220176 SPC	2/21/00	4:12a	0.03	6,603	2.42	0.378	7,928	2.485	4,623
DO220177 SPC	2/21/00	4:17a	0.03	6,644	2.413	0.379	7,948	2.479	4,646
DO220178 SPC	2/21/00	4:21a	0.029	6,568	2.388	0.38	7,916	2.526	4,636
DO220179 SPC	2/21/00	4:26a	0.028	6,474	2.37	0.381	7,872	2.538	4,532
DO220180 SPC	2/21/00	4:30a	0.028	6,433	2.343	0.383	7,800	2.555	4,479
DO220181 SPC	2/21/00	4:35a	0.029	6,405	2.309	0.385	7,765	2.539	4,440

Table C-4. (Continued)

Collection Data			Quantification Method Concentrations in ppm						
			Olin Mercury Plant		Olin 2		Olin 3		
File	Date	Time	sulfur hexafluoride	water	carbon monoxide	nitrous oxide	water	methane	Water
DO220182 SPC	2/21/00	4:39a	0.031	6,354	2.281	0.388	7,714	2.507	4,405
DO220183 SPC	2/21/00	4:44a	0.03	6,309	2.257	0.389	7,657	2.447	4,313
DO220184 SPC	2/21/00	4:49a	0.03	6,259	2.243	0.393	7,574	2.395	4,220
DO220185 SPC	2/21/00	4:53a	0.029	6,196	2.246	0.393	7,584	2.392	4,213
DO220186 SPC	2/21/00	9:05a	0.004	5,494	2.066	0.374	7,248	1.978	3,887
DO220187 SPC	2/21/00	9:09a	0.003	5,584	2.051	0.374	7,276	1.976	3,959
DO220188 SPC	2/21/00	9:14a	0.003	5,416	2.058	0.373	7,116	1.972	3,774
DO220189 SPC	2/21/00	9:18a	0.003	5,355	2.047	0.374	7,060	1.975	3,725
DO220190 SPC	2/21/00	9:23a	0.002	5,410	2.049	0.373	7,104	1.978	3,768
DO220191 SPC	2/21/00	9:27a	0.002	5,461	2.06	0.373	7,108	1.981	3,757
DO220192 SPC	2/21/00	9:32a	0.002	5,439	2.09	0.373	7,230	1.979	3,913
DO220193 SPC	2/21/00	9:37a	0.002	5,501	2.043	0.373	7,186	1.969	3,855
DO220194 SPC	2/21/00	9:41a	0.002	5,477	2.05	0.373	7,170	1.985	3,842
DO220195 SPC	2/21/00	9:46a	0.002	5,446	2.039	0.372	7,159	1.975	3,784
DO220196 SPC	2/21/00	9:50a	0.001	5,668	2.039	0.371	7,382	1.981	4,012
DO220197 SPC	2/21/00	9:55a	0.002	5,664	2.062	0.372	7,360	1.973	4,051
DO220198 SPC	2/21/00	10:06a	0.002	5,588	2.052	0.371	7,344	1.978	4,008
DO220199 SPC	2/21/00	10:12a	0.002	5,530	2.08	0.372	7,193	1.969	3,869
DO220200 SPC	2/21/00	10:17a	0.002	5,424	2.061	0.372	7,144	1.967	3,770
DO220201 SPC	2/21/00	10:22a	0.001	5,471	2.032	0.37	7,124	1.976	3,781
DO220202 SPC	2/21/00	10:26a	0.001	5,465	2.047	0.371	7,185	1.974	3,841
DO220203 SPC	2/21/00	10:31a	0.002	5,750	2.056	0.371	7,179	1.972	3,818
DO220204 SPC	2/21/00	10:35a	0.001	5,640	2.087	0.371	7,331	1.976	3,960
DO220205 SPC	2/21/00	10:40a	0.002	6,096	2.092	0.37	7,475	1.977	4,143
DO220206 SPC	2/21/00	10:44a	0.002	5,734	2.055	0.37	7,233	1.977	3,827
DO220207 SPC	2/21/00	10:49a	0.001	5,424	2.056	0.37	7,182	1.982	3,766
DO220208 SPC	2/21/00	10:53a	0.001	5,472	2.046	0.371	7,174	1.982	3,782
DO220209 SPC	2/21/00	10:58a	0.002	5,599	2.046	0.37	7,288	1.988	3,843
DO220210 SPC	2/21/00	11:03a	0.002	5,910	2.047	0.37	7,434	1.984	3,979
DO220211 SPC	2/21/00	11:07a	0.002	5,625	2.022	0.369	7,333	2.043	3,608

Table C-4. (Continued)

Collection Data			Olin Mercury Plant				Olin 2		Olin 3	
File	Date	Time	Quantification Method		Concentrations in ppm		water	methane	Water	
			sulfur hexafluoride	water	carbon monoxide	nitrous oxide				
DO220212 SPC	2/21/00	11:12a	0.002	5,715	2.033	0.369	7,301	2.008	3,809	
DO220213 SPC	2/21/00	11:16a	0.002	5,695	2.043	0.369	7,298	1.978	3,873	
DO220214 SPC	2/21/00	11:21a	0.001	5,752	2.038	0.37	7,294	1.972	3,878	
DO220215 SPC	2/21/00	11:25a	0.002	5,726	2.027	0.369	7,317	1.97	3,947	
DO220216 SPC	2/21/00	11:30a	0.002	6,154	2.017	0.368	7,563	1.971	4,209	
DO220217 SPC	2/21/00	11:34a	0.001	5,834	2.021	0.369	7,262	1.975	3,916	
DO220218 SPC	2/21/00	11:39a	0.001	5,683	2.037	0.369	7,288	1.971	3,943	
DO220219 SPC	2/21/00	11:46a	0.001	5,706	2.023	0.369	7,339	1.968	3,948	
DO220220 SPC	2/21/00	11:50a	0.001	6,039	2.024	0.368	7,521	1.971	4,162	
DO220221 SPC	2/21/00	11:55a	0.001	5,802	2.015	0.368	7,425	1.961	4,099	
DO220222 SPC	2/21/00	11:59a	0.001	6,123	2.023	0.368	7,485	1.967	4,147	
DO220223 SPC	2/21/00	12:04p	0.001	6,063	2.026	0.368	7,549	1.965	4,199	
DO220224 SPC	2/21/00	12:08p	0.001	5,800	2.016	0.368	7,361	1.962	4,001	
DO220225 SPC	2/21/00	12:13p	0.001	5,867	2.026	0.368	7,366	1.966	3,981	
DO220226 SPC	2/21/00	12:26p	0	5,995	2.021	0.369	7,487	1.971	4,113	
DO220227 SPC	2/21/00	12:31p	0	5,892	2.024	0.367	7,486	1.967	4,094	
DO220228 SPC	2/21/00	12:35p	0	5,899	2.023	0.367	7,521	1.972	4,136	
DO220229 SPC	2/21/00	12:40p	0	5,959	2.024	0.367	7,525	1.964	4,127	
DO220230 SPC	2/21/00	12:44p	0	6,045	2.057	0.367	7,534	1.982	4,120	
DO220231 SPC	2/21/00	12:49p	0	6,091	2.03	0.367	7,517	1.978	4,097	
DO220232 SPC	2/21/00	12:53p	0	6,003	2.026	0.366	7,555	1.987	4,094	
DO220233 SPC	2/21/00	12:58p	0	5,999	2.027	0.366	7,588	2.009	4,026	
DO220234 SPC	2/21/00	1:02p	0	5,966	2.025	0.367	7,496	1.982	4,113	
DO220235 SPC	2/21/00	1:07p	0	6,036	2.044	0.367	7,552	2.013	4,059	
DO220236 SPC	2/21/00	1:11p	0	6,188	2.036	0.367	7,623	1.999	4,141	
DO220237 SPC	2/21/00	1:16p	0	6,137	2.03	0.366	7,636	1.997	4,199	
DO220238 SPC	2/21/00	1:21p	0	6,010	2.03	0.367	7,609	2.002	4,169	
DO220239 SPC	2/21/00	1:25p	0	6,135	2.035	0.366	7,618	1.986	4,189	
DO220240 SPC	2/21/00	1:30p	0	6,044	2.029	0.367	7,610	1.996	4,227	
DO220241 SPC	2/21/00	1:34p	0	6,190	2.029	0.366	7,697	2	4,303	

C-37

C-37

Table C-4. (Continued)

Collection Data			Quantification Method Concentrations in ppm						
File	Date	Time	Olin Mercury Plant		Olin 2		Olin 3		
			sulfur hexafluoride	water	carbon monoxide	nitrous oxide	water	methane	Water
DO220242 SPC	2/21/00	1:39p	0	6,157	2.045	0.366	7,718	1.989	4,373
DO220243 SPC	2/21/00	1:43p	0	6,031	2.036	0.367	7,645	1.994	4,246
DO220244 SPC	2/21/00	1:48p	0	6,125	2.052	0.366	7,669	2.017	4,257
DO220245 SPC	2/21/00	1:52p	0	6,162	2.065	0.366	7,639	1.999	4,204
DO220246 SPC	2/21/00	1:57p	0	6,279	2.064	0.366	7,767	1.998	4,335
DO220247 SPC	2/21/00	2:02p	0	6,250	2.07	0.366	7,783	2.018	4,384
DO220248 SPC	2/21/00	2:06p	0	6,273	2.087	0.366	7,736	2.018	4,338
DO220249 SPC	2/21/00	2:11p	0	6,168	2.054	0.366	7,656	1.997	4,268
DO220250 SPC	2/21/00	2:15p	0	6,283	2.091	0.368	7,722	2.012	4,348
DO220251 SPC	2/21/00	2:20p	0	6,485	2.049	0.367	7,851	2.019	4,505
DO220252 SPC	2/21/00	2:24p	0	6,334	2.068	0.367	7,764	2.002	4,363
DO220253 SPC	2/21/00	2:29p	0	6,276	2.052	0.367	7,790	2.007	4,430
DO220254 SPC	2/21/00	2:33p	0	6,379	2.061	0.369	7,796	2.043	4,369
DO220255 SPC	2/21/00	2:38p	0	6,459	2.07	0.368	7,908	2.044	4,508
DO220256 SPC	2/21/00	2:42p	0	6,632	2.076	0.369	7,999	2.014	4,628
DO220257 SPC	2/21/00	2:47p	0	6,615	2.077	0.369	8,031	2.017	4,656
DO220258 SPC	2/21/00	2:52p	0	6,532	2.093	0.37	7,920	2.021	4,530
DO220259 SPC	2/21/00	2:56p	0	6,572	2.107	0.371	7,957	2.022	4,544
DO220260 SPC	2/21/00	3:01p	0	6,449	2.077	0.373	7,810	1.996	4,380
DO220261 SPC	2/21/00	3:05p	0	6,414	2.071	0.371	7,798	1.998	4,395
DO220262 SPC	2/21/00	3:10p	0	6,345	2.062	0.37	7,788	2.012	4,418
DO220263 SPC	2/21/00	3:14p	0	6,271	2.069	0.371	7,738	2.016	4,315
DO220264 SPC	2/21/00	3:19p	0	6,387	2.088	0.373	7,834	2.011	4,444
DO220265 SPC	2/21/00	3:23p	0	6,375	2.092	0.374	7,851	2.003	4,423
DO220266 SPC	2/21/00	3:28p	0	6,426	2.101	0.373	7,836	2.005	4,421
DO220267 SPC	2/21/00	3:32p	0	6,350	2.097	0.373	7,788	2.013	4,354
DO220268 SPC	2/21/00	3:37p	0	6,234	2.077	0.372	7,714	2.009	4,303
DO220269 SPC	2/21/00	3:41p	0	6,212	2.069	0.37	7,630	2.001	4,246
DO220270 SPC	2/21/00	3:46p	0	6,330	2.074	0.37	7,715	1.997	4,300
DO220271 SPC	2/21/00	3:51p	0	6,229	2.084	0.373	7,652	2.005	4,245

C-38

C-38

Table C-4. (Continued)

Collection Data			Quantification Method Concentrations in ppm						
			Olin Mercury Plant		Olin 2		Olin 3		
File	Date	Time	sulfur hexafluoride	water	carbon monoxide	nitrous oxide	water	methane	Water
DO220272 SPC	2/21/00	3:55p	0	6,234	2.087	0.372	7,661	2.016	4,272
DO220273 SPC	2/21/00	4:00p	0	6,157	2.068	0.37	7,550	2.015	4,155
DO220274 SPC	2/21/00	4:04p	0	6,239	2.135	0.372	7,659	2.031	4,223
DO220275 SPC	2/21/00	4:09p	0	6,528	2.074	0.371	7,832	2.02	4,462
DO220276 SPC	2/21/00	4:13p	0	6,362	2.079	0.371	7,785	1.999	4,389
DO220277 SPC	2/21/00	4:18p	0	6,286	2.081	0.371	7,730	1.994	4,269
DO220278 SPC	2/21/00	4:22p	0	6,373	2.08	0.369	7,782	1.994	4,377
DO220279 SPC	2/21/00	4:27p	0	6,284	2.081	0.37	7,678	1.981	4,221
DO220280 SPC	2/21/00	4:31p	0	6,062	2.066	0.37	7,566	1.982	4,136
DO220281 SPC	2/21/00	4:36p	0	6,225	2.07	0.372	7,656	1.992	4,253
DO220282 SPC	2/21/00	4:41p	0	6,159	2.065	0.373	7,568	1.976	4,150
DO220283 SPC	2/21/00	4:45p	0	6,197	2.094	0.372	7,626	2	4,218
DO220284 SPC	2/21/00	4:50p	0	6,172	2.074	0.371	7,599	1.984	4,141
DO220285 SPC	2/21/00	4:54p	0	6,218	2.06	0.369	7,569	1.976	4,127
DO220286 SPC	2/21/00	4:59p	0	6,075	2.068	0.367	7,583	1.973	4,134
DO220287 SPC	2/21/00	5:03p	0	6,124	2.059	0.369	7,581	1.974	4,141
DO220288 SPC	2/21/00	5:08p	0	6,095	2.06	0.369	7,550	1.991	4,135
DO220289 SPC	2/21/00	5:12p	0	6,198	2.065	0.368	7,656	1.988	4,232
DO220290 SPC	2/21/00	5:17p	0	6,343	2.059	0.369	7,696	1.99	4,281
DO220291 SPC	2/21/00	5:22p	0	6,095	2.062	0.369	7,650	1.99	4,245
DO220292 SPC	2/21/00	5:26p	0	6,164	2.045	0.369	7,586	1.987	4,167
DO220293 SPC	2/21/00	5:31p	0	6,177	2.047	0.368	7,572	1.992	4,164
DO220294 SPC	2/21/00	5:35p	0	6,133	2.05	0.369	7,630	1.977	4,203
DO220295 SPC	2/21/00	5:40p	0	6,290	2.062	0.369	7,629	1.979	4,239
DO220296 SPC	2/21/00	5:44p	0	6,154	2.051	0.369	7,626	1.981	4,232
DO220297 SPC	2/21/00	5:49p	0	6,205	2.049	0.368	7,645	1.973	4,238
DO220298 SPC	2/21/00	5:53p	0	6,324	2.048	0.368	7,689	1.968	4,318
DO220299 SPC	2/21/00	5:58p	0	6,184	2.044	0.368	7,649	1.971	4,261
DO220300 SPC	2/21/00	6:02p	0	6,120	2.047	0.368	7,595	1.969	4,199
DO220301 SPC	2/21/00	6:07p	0	6,230	2.051	0.368	7,677	1.969	4,274

Table C-4. (Continued)

Collection Data			Quantification Method Concentrations in ppm						
File	Date	Time	Olin Mercury Plant		Olin 2		Olin 3		
			sulfur hexafluoride	water	carbon monoxide	nitrous oxide	water	methane	Water
DO220302 SPC	2/21/00	6:12p	0	6,361	2.042	0.369	7,787	1.973	4,431
DO220303 SPC	2/21/00	6:16p	0	6,442	2.085	0.369	7,812	1.97	4,429
DO220304 SPC	2/21/00	6:21p	0	6,470	2.055	0.368	7,804	1.97	4,404
DO220305 SPC	2/21/00	6:25p	0	6,601	2.045	0.367	7,951	1.967	4,586
DO220306 SPC	2/21/00	6:30p	0	6,506	2.035	0.365	7,986	1.96	4,629
DO220307 SPC	2/21/00	6:34p	0	6,655	2.032	0.366	7,968	1.96	4,625
DO220308 SPC	2/21/00	6:39p	0	6,535	2.029	0.366	7,940	1.967	4,593
DO220309 SPC	2/21/00	6:43p	0	6,493	2.03	0.366	7,952	1.959	4,595
DO220310 SPC	2/21/00	6:48p	0	6,471	2.029	0.366	7,895	1.959	4,514
DO220311 SPC	2/21/00	6:52p	0	6,506	2.026	0.366	7,915	1.96	4,578
DO220312 SPC	2/21/00	6:57p	0	6,627	2.03	0.367	8,018	1.965	4,668
DO220313 SPC	2/21/00	7:02p	0	6,771	2.028	0.367	8,077	1.967	4,750
DO220314 SPC	2/21/00	7:06p	0	6,726	2.027	0.367	8,056	1.964	4,704
DO220315 SPC	2/21/00	7:11p	0	6,736	2.026	0.368	8,119	1.968	4,783
DO220316 SPC	2/21/00	7:15p	0	6,781	2.021	0.368	8,162	1.969	4,916
DO220317 SPC	2/21/00	7:20p	0	6,822	2.025	0.369	8,198	1.965	4,925
DO220318 SPC	2/21/00	7:24p	0	6,981	2.033	0.37	8,332	1.969	5,100
DO220319 SPC	2/21/00	7:29p	0	6,978	2.051	0.371	8,258	1.977	5,001
DO220320 SPC	2/21/00	7:33p	0	6,926	2.119	0.371	8,231	2.033	4,934
DO220321 SPC	2/21/00	7:38p	0	6,943	2.16	0.372	8,229	2.269	4,886
DO220322 SPC	2/21/00	7:42p	0	6,850	2.176	0.373	8,293	2.391	4,986
DO220323 SPC	2/21/00	7:47p	0	6,994	2.189	0.373	8,341	2.76	5,038
DO220324 SPC	2/21/00	7:52p	0	6,968	2.203	0.373	8,296	2.744	4,989
DO220325 SPC	2/21/00	7:56p	0	6,964	2.148	0.372	8,256	2.613	4,998
DO220326 SPC	2/21/00	8:01p	0	6,957	2.149	0.373	8,263	2.272	4,962
DO220327 SPC	2/21/00	8:05p	0	6,736	2.254	0.374	8,206	2.097	4,891
DO220328 SPC	2/21/00	8:10p	0	6,847	2.254	0.374	8,234	2.108	4,920
DO220329 SPC	2/21/00	8:14p	0	6,782	2.177	0.373	8,199	2.165	4,900
DO220330 SPC	2/21/00	8:19p	0	6,788	2.167	0.373	8,169	2.174	4,893
DO220331 SPC	2/21/00	8:23p	0	6,680	2.18	0.375	8,137	2.119	4,851

Table C-4. (Continued)

Collection Data			Quantification Method Concentrations in ppm							
File	Date	Time	Olin Mercury Plant		Olin 2		Olin 3			
			sulfur hexafluoride	water	carbon monoxide	nitrous oxide	water	methane	Water	
DO220332 SPC	2/21/00	8:28p	0	6,783	2.168	0.374	8,154	2.1	4,856	
DO220333 SPC	2/21/00	8:33p	0	6,980	2.207	0.374	8,232	2.245	4,871	
DO220334 SPC	2/21/00	8:37p	0	6,893	2.231	0.373	8,270	2.626	4,968	
DO220335 SPC	2/21/00	8:42p	0	6,905	2.205	0.373	8,304	2.557	4,971	
DO220336 SPC	2/21/00	8:46p	0	7,093	2.238	0.374	8,361	2.784	5,038	
DO220337 SPC	2/21/00	8:51p	0	7,030	2.254	0.374	8,330	2.593	5,018	
DO220338 SPC	2/21/00	8:55p	0	6,899	2.274	0.375	8,252	2.481	4,931	
DO220339 SPC	2/21/00	9:00p	0	6,826	2.227	0.375	8,209	2.416	4,872	
DO220340 SPC	2/21/00	9:04p	0	6,903	2.223	0.375	8,254	2.494	4,928	
DO220341 SPC	2/21/00	9:09p	0	6,966	2.225	0.375	8,371	3.264	5,011	
DO220342 SPC	2/21/00	9:14p	0	7,209	2.227	0.375	8,464	4.103	5,051	
DO220343 SPC	2/21/00	9:18p	0	7,020	2.243	0.375	8,381	3.379	5,026	
DO220344 SPC	2/21/00	9:23p	0	6,990	2.306	0.376	8,383	2.843	5,039	
DO220345 SPC	2/21/00	9:27p	0	6,960	2.31	0.376	8,329	2.371	5,012	
DO220346 SPC	2/21/00	9:32p	0	6,961	2.27	0.376	8,332	2.38	5,038	
DO220347 SPC	2/21/00	9:36p	0	6,875	2.242	0.376	8,256	2.36	4,956	
DO220348 SPC	2/21/00	9:41p	0	6,755	2.239	0.376	8,223	2.35	4,891	
DO220349 SPC	2/21/00	9:46p	0	6,834	2.336	0.376	8,243	2.419	4,899	
DO220350 SPC	2/21/00	9:50p	0	6,842	3.158	0.382	8,310	2.402	4,811	
DO220351 SPC	2/21/00	9:55p	0	6,865	2.532	0.378	8,266	2.285	4,874	
DO220352 SPC	2/21/00	9:59p	0	6,859	2.262	0.377	8,241	2.301	4,927	
DO220353 SPC	2/21/00	10:04p	0	6,676	2.246	0.376	8,144	2.326	4,768	
DO220354 SPC	2/21/00	10:08p	0	6,715	2.234	0.376	8,122	2.29	4,758	
DO220355 SPC	2/21/00	10:13p	0	6,772	2.294	0.376	8,208	2.312	4,795	
DO220356 SPC	2/21/00	10:18p	0	6,661	2.278	0.377	8,145	2.232	4,800	
DO220357 SPC	2/21/00	10:22p	0	6,683	2.313	0.377	8,121	2.238	4,726	
DO220358 SPC	2/21/00	10:27p	0	6,658	2.303	0.377	8,156	2.24	4,775	
DO220359 SPC	2/21/00	10:31p	0	6,633	2.272	0.378	8,126	2.277	4,762	
DO220360 SPC	2/21/00	10:36p	0	6,618	2.277	0.378	8,102	2.258	4,716	
DO220361 SPC	2/21/00	10:40p	0	6,575	2.277	0.378	8,072	2.268	4,719	

Table C-4. (Continued)

Collection Data			Quantification Method Concentrations in ppm						
			Olin Mercury Plant		Olin 2		Olin 3		
File	Date	Time	sulfur hexafluoride	water	carbon monoxide	nitrous oxide	water	methane	Water
DO220362 SPC	2/21/00	10:45p	0	6,566	2.255	0.378	8,022	2.269	4,647
DO220363 SPC	2/21/00	10:50p	0	6,557	2.27	0.379	8,039	2.228	4,692
DO220364 SPC	2/21/00	10:54p	0	6,605	2.261	0.378	8,081	2.244	4,771
DO220365 SPC	2/21/00	10:59p	0	6,704	2.345	0.379	8,172	2.258	4,864
DO220366 SPC	2/21/00	11:03p	0	6,622	2.393	0.38	8,140	2.149	4,847
DO220367 SPC	2/21/00	11:08p	0	6,537	2.349	0.38	8,057	2.146	4,761
DO220368 SPC	2/21/00	11:12p	0	6,603	2.327	0.379	8,089	2.162	4,789
DO220369 SPC	2/21/00	11:17p	0	6,633	2.276	0.378	8,162	2.219	4,875
DO220370 SPC	2/21/00	11:22p	0	6,995	2.266	0.377	8,424	2.273	5,141
DO220371 SPC	2/21/00	11:26p	0	7,091	2.318	0.379	8,528	2.79	5,182
DO220372 SPC	2/21/00	11:31p	0	7,318	2.305	0.379	8,660	4.833	5,174
DO220373 SPC	2/21/00	11:35p	0	7,256	2.375	0.38	8,590	4.279	5,016
DO220374 SPC	2/21/00	11:40p	0	8,234	2.374	0.379	9,238	8.988	5,222
DO220375 SPC	2/21/00	11:44p	0	8,489	2.312	0.379	9,372	11.253	5,333
DO220376 SPC	2/21/00	11:49p	0	8,227	2.309	0.379	9,246	12.173	5,134
DO220377 SPC	2/21/00	11:54p	0	7,639	2.372	0.381	8,848	7.817	4,869
DO220378 SPC	2/21/00	11:58p	0	7,394	2.38	0.381	8,704	7.133	4,717
DO220379 SPC	2/22/00	12:03a	0	7,168	2.379	0.381	8,559	6.394	4,754
DO220380 SPC	2/22/00	12:07a	0	7,100	2.381	0.381	8,503	5.486	4,826
DO220381 SPC	2/22/00	12:12a	0	7,027	2.384	0.381	8,458	5.11	4,710
DO220382 SPC	2/22/00	12:16a	0	6,849	2.366	0.381	8,351	4.421	4,740
DO220383 SPC	2/22/00	12:21a	0	6,883	2.338	0.381	8,323	4.217	4,676
DO220384 SPC	2/22/00	12:26a	0	6,721	2.34	0.382	8,210	3.892	4,641
DO220385 SPC	2/22/00	12:30a	0	6,633	2.346	0.381	8,143	3.612	4,549
DO220386 SPC	2/22/00	12:35a	0	6,583	2.352	0.381	8,144	3.125	4,652
DO220387 SPC	2/22/00	12:39a	0	6,588	2.366	0.382	8,103	2.893	4,696
DO220388 SPC	2/22/00	12:44a	0	6,501	2.381	0.381	8,061	2.889	4,632
DO220389 SPC	2/22/00	12:48a	0	6,503	2.379	0.382	8,061	3.053	4,587
DO220390 SPC	2/22/00	12:53a	0	6,415	2.378	0.382	7,995	2.787	4,605
DO220391 SPC	2/22/00	12:58a	0	6,342	2.374	0.382	7,963	2.544	4,615

Table C-4. (Continued)

Collection Data			Quantification Method Concentrations in ppm						
			Olin Mercury Plant		Olin 2		Olin 3		
File	Date	Time	sulfur hexafluoride	water	carbon monoxide	nitrous oxide	water	methane	Water
DO220392 SPC	2/22/00	1:02a	0	6,409	2.359	0.382	7,959	2.58	4,566
DO220393 SPC	2/22/00	1:07a	0	6,271	2.349	0.382	7,909	2.547	4,533
DO220394 SPC	2/22/00	1:11a	0	6,362	2.349	0.382	7,896	2.587	4,536
DO220395 SPC	2/22/00	1:16a	0	6,228	2.316	0.382	7,860	2.474	4,518
DO220396 SPC	2/22/00	1:20a	0	6,200	2.294	0.382	7,806	2.396	4,493
DO220397 SPC	2/22/00	1:25a	0	6,205	2.298	0.382	7,784	2.407	4,486
DO220398 SPC	2/22/00	1:30a	0	6,130	2.294	0.383	7,754	2.399	4,445
DO220399 SPC	2/22/00	1:34a	0	6,128	2.292	0.382	7,747	2.39	4,440
DO220400 SPC	2/22/00	1:39a	0	6,078	2.291	0.382	7,700	2.4	4,406
DO220401 SPC	2/22/00	1:43a	0	6,033	2.299	0.383	7,638	2.402	4,361
DO220402 SPC	2/22/00	1:48a	0	6,121	2.338	0.383	7,776	2.422	4,481
DO220403 SPC	2/22/00	1:53a	0	6,243	2.301	0.382	7,823	2.451	4,535
DO220404 SPC	2/22/00	1:57a	0	6,236	2.32	0.382	7,841	2.504	4,553
DO220405 SPC	2/22/00	2:02a	0	6,117	2.321	0.383	7,735	2.453	4,415
DO220406 SPC	2/22/00	2:06a	0	5,925	2.278	0.384	7,579	2.444	4,303
DO220407 SPC	2/22/00	2:11a	0	5,993	2.295	0.383	7,584	2.497	4,307
DO220408 SPC	2/22/00	2:15a	0	5,937	2.319	0.384	7,629	2.561	4,340
DO220409 SPC	2/22/00	2:20a	0	5,983	2.334	0.384	7,640	2.59	4,337
DO220410 SPC	2/22/00	2:25a	0	6,017	2.356	0.383	7,671	2.683	4,388
DO220411 SPC	2/22/00	2:29a	0	6,043	2.418	0.384	7,692	2.689	4,378
DO220412 SPC	2/22/00	2:34a	0	6,027	2.353	0.383	7,670	2.674	4,389
DO220414 SPC	2/22/00	2:43a	0	5,895	2.375	0.383	7,563	2.632	4,253
DO220415 SPC	2/22/00	2:47a	0	5,880	2.37	0.383	7,536	2.652	4,236
DO220416 SPC	2/22/00	2:52a	0	5,791	2.348	0.384	7,483	2.688	4,193
DO220417 SPC	2/22/00	2:56a	0	5,828	2.342	0.383	7,519	2.782	4,250
DO220418 SPC	2/22/00	3:01a	0	5,956	2.348	0.384	7,578	2.886	4,288
DO220419 SPC	2/22/00	3:06a	0	5,882	2.335	0.384	7,515	2.869	4,251
DO220420 SPC	2/22/00	3:10a	0	5,853	2.343	0.384	7,513	2.945	4,216
DO220421 SPC	2/22/00	3:15a	0	5,908	2.358	0.384	7,534	2.961	4,241
DO220422 SPC	2/22/00	3:19a	0	5,853	2.386	0.385	7,516	2.999	4,208

Table C-4. (Continued)

Collection Data			Quantification Method Concentrations in ppm						
File	Date	Time	Olin Mercury Plant		Olin 2		Olin 3		
			sulfur hexafluoride	water	carbon monoxide	nitrous oxide	water	methane	Water
DO220423 SPC	2/22/00	3:24a	0	5,732	2.403	0.385	7,482	2.979	4,170
DO220424 SPC	2/22/00	3:29a	0	5,735	2.45	0.385	7,501	2.934	4,205
DO220425 SPC	2/22/00	3:33a	0	5,893	2.465	0.384	7,547	2.938	4,260
DO220426 SPC	2/22/00	3:38a	0	5,837	2.486	0.385	7,537	2.953	4,248
DO220427 SPC	2/22/00	3:42a	0	5,848	2.518	0.385	7,559	2.959	4,248
DO220428 SPC	2/22/00	3:47a	0	5,931	2.466	0.385	7,596	2.884	4,280
DO220429 SPC	2/22/00	3:51a	0	5,918	2.471	0.385	7,610	2.87	4,290
DO220430 SPC	2/22/00	3:56a	0	5,881	2.482	0.385	7,563	2.863	4,245
DO220431 SPC	2/22/00	4:01a	0	5,839	2.498	0.385	7,493	2.864	4,192
DO220432 SPC	2/22/00	4:05a	0	5,767	2.524	0.385	7,485	2.891	4,169
DO220433 SPC	2/22/00	4:10a	0	5,691	2.495	0.386	7,441	2.95	4,143
DO220434 SPC	2/22/00	4:14a	0	5,828	2.532	0.386	7,523	2.933	4,216
DO220435 SPC	2/22/00	4:19a	0	5,903	2.565	0.386	7,557	2.928	4,225
DO220436 SPC	2/22/00	4:24a	0	5,868	2.531	0.386	7,490	3.015	4,167
DO220437 SPC	2/22/00	4:28a	0	5,756	2.531	0.387	7,464	3.045	4,161
DO220438 SPC	2/22/00	4:33a	0	5,805	2.5	0.386	7,455	3.105	4,114
DO220439 SPC	2/22/00	4:37a	0	5,824	2.522	0.387	7,455	3.105	4,127
DO220440 SPC	2/22/00	4:42a	0	5,839	2.531	0.387	7,452	3.1	4,123
DO220441 SPC	2/22/00	4:46a	0	5,875	2.567	0.387	7,496	3.1	4,188
DO220442 SPC	2/22/00	4:51a	0	5,749	2.537	0.387	7,447	3.149	4,124
DO220443 SPC	2/22/00	4:56a	0	5,746	2.551	0.386	7,435	3.136	4,117
DO220444 SPC	2/22/00	5:00a	0	5,797	2.596	0.386	7,481	3.146	4,164
DO220445 SPC	2/22/00	5:05a	0	5,805	2.593	0.387	7,456	3.168	4,093
DO220446 SPC	2/22/00	5:09a	0	5,747	2.611	0.387	7,441	3.178	4,101
DO220447 SPC	2/22/00	5:14a	0	5,671	2.531	0.387	7,407	3.209	4,084
DO220448 SPC	2/22/00	5:19a	0	5,753	2.526	0.388	7,400	3.227	4,064
DO220449 SPC	2/22/00	5:23a	0	5,646	2.508	0.387	7,357	3.272	4,006
DO220450 SPC	2/22/00	5:28a	0	5,715	2.515	0.387	7,396	3.26	4,054
DO220451 SPC	2/22/00	5:32a	0	5,807	2.536	0.388	7,412	3.223	4,106
DO220452 SPC	2/22/00	5:37a	0	5,752	2.563	0.389	7,468	3.174	4,150

Table C-4. (Continued)

Collection Data			Quantification Method Concentrations in ppm						
			Olin Mercury Plant		Olin 2		Olin 3		
File	Date	Time	sulfur hexafluoride	water	carbon monoxide	nitrous oxide	water	methane	Water
DO220453 SPC	2/22/00	5:42a	0	5,778	2.567	0.388	7,490	3.116	4,161
DO220454 SPC	2/22/00	5:46a	0	5,744	2.567	0.389	7,434	3.143	4,098
DO220455 SPC	2/22/00	5:51a	0	5,773	2.594	0.388	7,480	3.103	4,158
DO220456 SPC	2/22/00	5:55a	0	5,714	2.664	0.389	7,415	3.146	4,046
DO220457 SPC	2/22/00	6:00a	0	5,664	2.695	0.389	7,360	3.211	3,948
DO220458 SPC	2/22/00	6:04a	0	5,760	2.615	0.389	7,431	3.166	4,103
DO220459 SPC	2/22/00	6:09a	0	5,813	2.611	0.388	7,481	3.132	4,126
DO220460 SPC	2/22/00	6:14a	0	5,749	2.638	0.389	7,464	3.166	4,078
DO220461 SPC	2/22/00	6:18a	0	5,762	2.812	0.39	7,501	3.112	4,116
DO220462 SPC	2/22/00	6:23a	0	5,752	2.625	0.389	7,476	3.1	4,069
DO220463 SPC	2/22/00	6:27a	0	5,680	2.624	0.39	7,388	3.147	4,007
DO220464 SPC	2/22/00	6:32a	0	5,734	2.673	0.391	7,417	3.132	4,034
DO220465 SPC	2/22/00	6:36a	0	5,786	2.654	0.392	7,382	3.107	4,036
DO220466 SPC	2/22/00	6:41a	0	5,629	2.821	0.393	7,413	3.128	4,029
DO220467 SPC	2/22/00	6:46a	0	5,581	2.757	0.394	7,355	3.15	3,972
DO220468 SPC	2/22/00	6:50a	0	5,653	2.798	0.395	7,375	3.099	4,010
DO220469 SPC	2/22/00	6:55a	0	5,665	2.647	0.395	7,394	3.038	4,023
DO220470 SPC	2/22/00	6:59a	0	5,696	2.669	0.394	7,420	3.015	4,064
DO220471 SPC	2/22/00	7:04a	0	5,759	2.661	0.394	7,402	2.983	4,072
DO220472 SPC	2/22/00	7:08a	0	5,515	2.68	0.395	7,368	3.009	3,959
DO220473 SPC	2/22/00	7:13a	0	5,533	2.735	0.396	7,330	3.076	3,911
DO220474 SPC	2/22/00	7:18a	0	5,599	2.73	0.395	7,344	3.028	3,935
DO220475 SPC	2/22/00	7:22a	0	5,680	2.768	0.398	7,407	3.038	4,008
DO220476 SPC	2/22/00	7:27a	0	5,789	2.861	0.397	7,438	3.047	4,016
DO220477 SPC	2/22/00	7:31a	0	5,726	3.109	0.4	7,471	3.032	4,000
DO220478 SPC	2/22/00	7:36a	0	5,851	2.908	0.401	7,550	2.965	4,113
DO220479 SPC	2/22/00	7:41a	0	5,816	2.928	0.399	7,566	2.961	4,157
DO220480 SPC	2/22/00	7:45a	0	5,939	2.816	0.398	7,606	2.897	4,185
DO220481 SPC	2/22/00	7:50a	0	5,960	2.858	0.398	7,670	2.875	4,289
DO220482 SPC	2/22/00	7:54a	0	5,951	2.846	0.397	7,698	2.866	4,296

Table C-4. (Continued)

Collection Data			Quantification Method Concentrations in ppm						
			Olin Mercury Plant		Olin 2			Olin 3	
File	Date	Time	sulfur hexafluoride	water	carbon monoxide	nitrous oxide	water	methane	Water
DO220483 SPC	2/22/00	7:59a	0	6,102	2.78	0.398	7,775	2.833	4,425
DO220484 SPC	2/22/00	8:03a	0	6,089	2.8	0.397	7,815	2.819	4,488
DO220485 SPC	2/22/00	8:08a	0	6,179	2.782	0.395	7,876	2.857	4,497
DO220486 SPC	2/22/00	8:13a	0.008	6,314	2.801	0.394	7,956	2.91	4,582
DO220487 SPC	2/22/00	8:17a	0	6,297	2.866	0.396	7,967	2.927	4,552
DO220488 SPC	2/22/00	8:22a	0	6,397	2.908	0.397	8,058	2.911	4,657
DO220489 SPC	2/22/00	8:26a	0	6,510	2.87	0.398	8,128	2.872	4,721
DO220490 SPC	2/22/00	8:31a	0	6,570	2.84	0.398	8,197	2.874	4,812
DO220491 SPC	2/22/00	8:35a	0	6,586	2.841	0.396	8,249	2.899	4,840
DO220492 SPC	2/22/00	8:40a	0	6,728	2.844	0.394	8,356	2.934	4,968
DO220493 SPC	2/22/00	8:45a	0	6,674	2.792	0.397	8,365	2.904	5,006
DO220494 SPC	2/22/00	8:49a	0	6,798	2.788	0.397	8,415	2.838	5,025
DO220495 SPC	2/22/00	8:54a	0	6,926	2.73	0.394	8,467	2.78	5,081
DO220496 SPC	2/22/00	8:58a	0	6,906	2.707	0.393	8,459	2.769	5,060
DO220497 SPC	2/22/00	9:03a	0	7,025	2.728	0.393	8,609	2.795	5,248
DO220498 SPC	2/22/00	9:08a	0	7,119	2.719	0.395	8,686	2.898	5,332
DO220499 SPC	2/22/00	9:12a	0	7,185	2.708	0.399	8,761	3.044	5,454
DO220500 SPC	2/22/00	9:17a	0	7,305	2.702	0.402	8,861	3.081	5,566
DO220501 SPC	2/22/00	9:21a	0	7,367	2.657	0.402	8,871	3.01	5,565
DO220502 SPC	2/22/00	9:50a	0	7,456	2.178	0.385	8,809	2.306	5,610
DO220503 SPC	2/22/00	9:56a	0	7,490	2.168	0.38	8,844	2.282	5639

Table C-5.

Data Collection			Quantification Method Concentrations in ppm						
File	Date	Time	Olin Mercury Plant		Olin 2		Olin 3		
			sulfur hexafluoride	water	carbon monoxide	nitrous oxide	water	methane	Water
DO222002 SPC	2/22/00	12:01p	0.001	6163	1.998	0.365	7685	1.979	4272
DO222003 SPC	2/22/00	12:06p	0.001	6,148	1.982	0.365	7,583	1.981	4,212
DO222004 SPC	2/22/00	12:14p	0.001	6,083	2.028	0.366	7,635	2.008	4,247
DO222005 SPC	2/22/00	12:18p	0.001	6,352	1.988	0.365	7,773	1.99	4,397
DO222006 SPC	2/22/00	12:27p	0.001	6,360	1.967	0.365	7,779	1.994	4,425
DO222007 SPC	2/22/00	12:33p	0.001	6,564	1.966	0.364	7,962	2	4,645
DO222008 SPC	2/22/00	12:38p	0.001	6,394	1.977	0.364	7,786	1.996	4,411
DO222009 SPC	2/22/00	12:43p	0.001	6,389	1.983	0.364	7,801	1.998	4,433
DO222010 SPC	2/22/00	2:04p	0.001	6,756	1.988	0.363	8,052	2.072	4,745
DO222011 SPC	2/22/00	2:09p	0.001	7,289	1.961	0.361	8,383	2.053	5,071
DO222012 SPC	2/22/00	2:13p	0.001	7,077	1.959	0.362	8,175	2.066	4,909
DO222013 SPC	2/22/00	2:18p	0.001	6,792	1.963	0.363	8,042	2.052	4,700
DO222014 SPC	2/22/00	2:22p	0.002	6,594	1.982	0.364	7,960	2.045	4,633
DO222015 SPC	2/22/00	2:27p	0.002	6,680	2.094	0.364	7,939	2.039	4,553
DO222016 SPC	2/22/00	2:32p	0.001	6,540	2.04	0.363	7,875	2.036	4,473
DO222017 SPC	2/22/00	2:36p	0.001	6,476	2.005	0.363	7,816	2.038	4,400
DO222018 SPC	2/22/00	2:41p	0.001	6,677	1.98	0.361	7,945	2.039	4,558
DO222019 SPC	2/22/00	2:45p	0.001	6,899	2.014	0.362	8,074	2.055	4,749
DO222020 SPC	2/22/00	2:50p	0.001	6,814	1.997	0.362	8,044	2.022	4,653
DO222021 SPC	2/22/00	2:54p	0.001	7,128	1.986	0.361	8,321	2.037	4,966
DO222022 SPC	2/22/00	2:59p	0.001	7,345	1.962	0.361	8,189	2.04	4,813
DO222023 SPC	2/22/00	3:03p	0	7,629	1.973	0.359	8,205	2.06	4,832
DO222024 SPC	2/22/00	3:08p	0.001	7,750	1.964	0.359	8,277	2.053	4,902
DO222025 SPC	2/22/00	3:12p	0.001	7,264	1.955	0.361	7,958	2.016	4,558
DO222026 SPC	2/22/00	3:17p	0.001	7,277	1.96	0.361	7,959	2.026	4,526
DO222027 SPC	2/22/00	3:21p	0.001	6,973	1.968	0.361	7,940	2.014	4,485
DO222028 SPC	2/22/00	3:26p	0.001	7,070	1.973	0.361	7,988	2.039	4,562
DO222029 SPC	2/22/00	3:30p	0.001	7,061	1.959	0.36	7,910	2.007	4,518
DO222030 SPC	2/22/00	3:35p	0.001	7,100	1.977	0.361	7,854	2.002	4,433
DO222031 SPC	2/22/00	3:40p	0.001	7,038	1.965	0.361	7,974	2.021	4,547

C-47

Table C-5. (Continued)

Data Collection			Quantification Method Concentrations in ppm						
File	Date	Time	Olin Mercury Plant		Olin 2		Olin 3		
			sulfur hexafluoride	water	carbon monoxide	nitrous oxide	water	methane	Water
DO222032 SPC	2/22/00	3:44p	0.001	7,258	1.954	0.36	8,036	2.017	4,626
DO222033 SPC	2/22/00	3:49p	0.001	7,116	1.952	0.36	7,982	2.004	4,563
DO222034 SPC	2/22/00	3:53p	0.001	7,091	1.953	0.36	7,992	2.001	4,584
DO222035 SPC	2/22/00	3:58p	0.001	7,250	1.968	0.36	8,142	2.02	4,701
DO222036 SPC	2/22/00	4:02p	0.001	6,860	1.956	0.36	7,875	1.993	4,444
DO222037 SPC	2/22/00	4:07p	0.001	6,786	1.953	0.36	7,827	1.987	4,395
DO222038 SPC	2/22/00	4:11p	0.001	7,103	1.956	0.361	7,875	2.021	4,473
DO222039 SPC	2/22/00	4:16p	0.001	6,927	1.953	0.36	7,816	1.989	4,396
DO222040 SPC	2/22/00	4:20p	0.001	7,039	1.986	0.362	7,776	2.01	4,333
DO222041 SPC	2/22/00	4:25p	0.001	7,215	2.021	0.36	8,033	2.038	4,614
DO222042 SPC	2/22/00	4:29p	0.001	7,088	1.996	0.36	7,996	2.009	4,574
DO222043 SPC	2/22/00	4:34p	0.001	7,131	2.007	0.36	7,970	1.996	4,567
DO222044 SPC	2/22/00	4:38p	0.001	7,181	1.989	0.36	7,937	1.993	4,485
DO222045 SPC	2/22/00	4:43p	0.001	6,957	1.957	0.361	7,877	2.017	4,482
DO222046 SPC	2/22/00	4:47p	0.001	7,312	1.955	0.359	8,135	2	4,722
DO222047 SPC	2/22/00	4:52p	0.001	7,483	1.955	0.359	8,231	2.012	4,840
DO222048 SPC	2/22/00	4:57p	0.001	7,364	2.007	0.36	8,122	2.033	4,706
DO222049 SPC	2/22/00	5:01p	0.001	7,289	1.963	0.359	8,050	2.037	4,626
DO222050 SPC	2/22/00	5:06p	0.001	7,143	1.964	0.36	7,897	2.023	4,527
DO222051 SPC	2/22/00	5:10p	0.001	7,243	1.977	0.36	8,052	2.023	4,699
DO222052 SPC	2/22/00	5:15p	0.001	7,367	1.971	0.359	8,170	2.02	4,803
DO222053 SPC	2/22/00	5:19p	0.001	7,291	1.97	0.359	8,098	2.013	4,693
DO222054 SPC	2/22/00	5:24p	0.001	7,225	1.968	0.36	8,079	2.033	4,660
DO222055 SPC	2/22/00	5:28p	0.001	7,306	1.964	0.36	8,087	2.003	4,692
DO222056 SPC	2/22/00	5:33p	0.001	7,103	1.963	0.361	8,005	1.998	4,655
DO222057 SPC	2/22/00	5:37p	0.001	7,273	1.963	0.361	8,072	2.004	4,697
DO222058 SPC	2/22/00	5:42p	0.001	7,086	1.961	0.361	7,961	1.988	4,593
DO222059 SPC	2/22/00	5:46p	0.001	7,120	1.96	0.361	7,998	1.986	4,603
DO222060 SPC	2/22/00	5:51p	0.001	7,675	1.963	0.36	8,364	1.999	5,004
DO222061 SPC	2/22/00	5:56p	0	7,598	1.965	0.36	8,331	1.997	5,008

C-48

Table C-5. (Continued)

Data Collection			Quantification Method Concentrations in ppm						
File	Date	Time	Olin Mercury Plant		Olin 2		Olin 3		
			sulfur hexafluoride	water	carbon monoxide	nitrous oxide	water	methane	Water
DO222062 SPC	2/22/00	6:00p	0.001	7,642	1.97	0.36	8,381	1.99	5,048
DO222063 SPC	2/22/00	6:05p	0	7,727	1.961	0.361	8,419	1.996	5,094
DO222064 SPC	2/22/00	6:09p	0.001	7,691	1.958	0.361	8,445	1.974	5,131
DO222065 SPC	2/22/00	6:14p	0.001	7,895	1.954	0.36	8,574	1.968	5,283
DO222066 SPC	2/22/00	6:18p	0.001	7,932	1.956	0.36	8,632	1.967	5,334
DO222067 SPC	2/22/00	6:23p	0.001	7,870	1.962	0.36	8,601	1.963	5,306
DO222068 SPC	2/22/00	6:27p	0.001	7,946	1.967	0.362	8,616	1.966	5,363
DO222069 SPC	2/22/00	6:32p	0.001	7,879	1.975	0.362	8,533	1.96	5,286
DO222070 SPC	2/22/00	6:36p	0.001	7,659	1.97	0.362	8,438	1.954	5,126
DO222071 SPC	2/22/00	6:41p	0.001	7,674	1.968	0.362	8,451	1.953	5,147
DO222072 SPC	2/22/00	6:45p	0.001	7,597	1.965	0.362	8,396	1.951	5,071
DO222073 SPC	2/22/00	6:50p	0.001	7,858	1.965	0.362	8,557	1.955	5,286
DO222074 SPC	2/22/00	6:55p	0.001	8,067	1.963	0.361	8,730	1.958	5,451
DO222075 SPC	2/22/00	6:59p	0.001	7,802	1.972	0.363	8,521	1.955	5,231
DO222076 SPC	2/22/00	7:04p	0.001	7,612	1.964	0.363	8,445	1.95	5,183
DO222077 SPC	2/22/00	7:08p	0.002	7,696	1.966	0.363	8,438	1.945	5,166
DO222078 SPC	2/22/00	7:13p	0.002	7,743	1.968	0.364	8,455	1.955	5,160
DO222079 SPC	2/22/00	7:17p	0.002	7,884	1.963	0.364	8,578	1.94	5,281
DO222080 SPC	2/22/00	7:22p	0.002	7,990	1.961	0.364	8,734	1.938	5,505
DO222081 SPC	2/22/00	7:26p	0.002	8,278	1.99	0.364	8,897	1.94	5,657
DO222082 SPC	2/22/00	7:31p	0.002	8,304	2.091	0.365	8,912	1.967	5,664
DO222083 SPC	2/22/00	7:35p	0.002	8,268	2.106	0.365	8,840	1.968	5,554
DO222084 SPC	2/22/00	7:40p	0.002	8,045	2.087	0.365	8,845	1.954	5,572
DO222085 SPC	2/22/00	7:45p	0.003	8,544	2.017	0.365	9,094	1.949	5,872
DO222086 SPC	2/22/00	7:49p	0.003	8,748	2.042	0.365	9,281	1.943	6,147
DO222087 SPC	2/22/00	7:54p	0.003	9,017	1.977	0.364	9,478	1.938	6,411
DO222088 SPC	2/22/00	7:58p	0.003	9,241	1.98	0.364	9,643	1.936	6,586
DO222089 SPC	2/22/00	8:03p	0.003	9,274	1.989	0.364	9,626	1.941	6,595
DO222090 SPC	2/22/00	8:07p	0.003	9,133	1.994	0.365	9,536	1.937	6,510
DO222091 SPC	2/22/00	8:12p	0.003	8,972	2.028	0.366	9,476	1.931	6,426

C-49

Table C-5. (Continued)

Data Collection			Quantification Method Concentrations in ppm						
File	Date	Time	Olin Mercury Plant		Olin 2		Olin 3		
			sulfur hexafluoride	water	carbon monoxide	nitrous oxide	water	methane	Water
DO222092 SPC	2/22/00	8:16p	0.003	8,911	2.031	0.366	9,425	1.939	6,334
DO222093 SPC	2/22/00	8:21p	0.003	8,616	2.047	0.367	9,283	1.932	6,134
DO222094 SPC	2/22/00	8:25p	0.003	8,513	2.018	0.368	9,117	1.931	5,960
DO222095 SPC	2/22/00	8:30p	0.004	8,373	2.011	0.368	9,070	1.94	5,941
DO222096 SPC	2/22/00	8:35p	0.004	8,429	1.982	0.368	9,044	1.939	5,865
DO222097 SPC	2/22/00	8:39p	0.004	8,165	1.964	0.367	8,818	1.934	5,623
DO222098 SPC	2/22/00	8:44p	0.004	8,182	2.001	0.368	8,917	1.954	5,689
DO222099 SPC	2/22/00	8:48p	0.004	8,292	2.054	0.368	8,934	2.013	5,646
DO222100 SPC	2/22/00	8:53p	0.004	8,059	2.012	0.369	8,843	1.992	5,596
DO222101 SPC	2/22/00	8:57p	0.004	8,032	1.993	0.37	8,772	1.968	5,555
DO222102 SPC	2/22/00	9:02p	0.005	8,011	1.981	0.368	8,756	1.976	5,489
DO222103 SPC	2/22/00	9:06p	0.005	7,884	1.999	0.37	8,685	1.97	5,402
DO222104 SPC	2/22/00	9:11p	0.005	7,915	2.012	0.37	8,643	1.974	5,350
DO222105 SPC	2/22/00	9:15p	0.005	7,934	2	0.37	8,575	1.969	5,258
DO222106 SPC	2/22/00	9:20p	0.005	7,812	2.011	0.37	8,586	2.006	5,304
DO222107 SPC	2/22/00	9:24p	0.005	7,752	2.066	0.37	8,594	2.037	5,315
DO222108 SPC	2/22/00	9:29p	0.006	7,822	2.06	0.37	8,572	2.01	5,257
DO222109 SPC	2/22/00	9:34p	0.006	7,766	2.062	0.371	8,639	2.007	5,335
DO222110 SPC	2/22/00	9:38p	0.006	7,858	2.059	0.37	8,648	2.014	5,346
DO222111 SPC	2/22/00	9:43p	0.006	7,800	2.076	0.371	8,564	2.001	5,248
DO222112 SPC	2/22/00	9:47p	0.006	7,719	2.041	0.371	8,490	2.006	5,245
DO222113 SPC	2/22/00	9:52p	0.006	7,695	2.035	0.37	8,511	2.018	5,239
DO222114 SPC	2/22/00	9:56p	0.007	7,666	2.049	0.37	8,500	2.051	5,165
DO222115 SPC	2/22/00	10:01p	0.007	7,615	2.102	0.37	8,560	2.083	5,224
DO222116 SPC	2/22/00	10:05p	0.007	7,885	2.098	0.37	8,612	2.107	5,326
DO222117 SPC	2/22/00	10:10p	0.008	7,838	2.013	0.369	8,686	2.146	5,480
DO222118 SPC	2/22/00	10:15p	0.007	8,164	1.995	0.369	8,864	2.191	5,698
DO222119 SPC	2/22/00	10:19p	0.007	8,046	2.027	0.37	8,823	2.208	5,593
DO222120 SPC	2/22/00	10:24p	0.007	7,987	2.077	0.37	8,812	2.152	5,563
DO222121 SPC	2/22/00	10:28p	0.007	8,002	2.039	0.37	8,730	2.15	5,478

C-50

Table C-5. (Continued)

Data Collection			Quantification Method Concentrations in ppm						
File	Date	Time	Olin Mercury Plant		Olin 2		Olin 3		
			sulfur hexafluoride	water	carbon monoxide	nitrous oxide	water	methane	Water
DO222122 SPC	2/22/00	10:33p	0.008	7,802	2.095	0.37	8,604	2.166	5,320
DO222123 SPC	2/22/00	10:37p	0.007	7,703	2.066	0.371	8,494	2.194	5,224
DO222124 SPC	2/22/00	10:42p	0.008	7,679	2.037	0.371	8,456	2.21	5,171
DO222125 SPC	2/22/00	10:47p	0.009	7,483	2.021	0.371	8,411	2.221	5,138
DO222126 SPC	2/22/00	10:51p	0.009	7,502	2.013	0.371	8,395	2.234	5,095
DO222127 SPC	2/22/00	10:56p	0.01	7,528	2.018	0.371	8,372	2.218	5,093
DO222128 SPC	2/22/00	11:00p	0.01	7,639	2.018	0.371	8,403	2.229	5,156
DO222129 SPC	2/22/00	11:05p	0.01	7,705	2.01	0.371	8,520	2.185	5,301
DO222130 SPC	2/22/00	11:09p	0.01	7,803	2.084	0.371	8,716	2.131	5,463
DO222131 SPC	2/22/00	11:14p	0.011	8,118	2.007	0.371	8,860	2.058	5,713
DO222132 SPC	2/22/00	11:18p	0.011	8,084	1.996	0.371	8,859	2.05	5,725
DO222133 SPC	2/22/00	11:23p	0.011	8,135	2.004	0.372	8,812	2.039	5,614
DO222134 SPC	2/22/00	11:27p	0.011	7,882	2.007	0.372	8,696	2.064	5,474
DO222135 SPC	2/22/00	11:32p	0.012	7,699	2.065	0.372	8,531	2.091	5,264
DO222136 SPC	2/22/00	11:37p	0.013	7,658	2.017	0.373	8,494	2.074	5,269
DO222137 SPC	2/22/00	11:41p	0.014	7,542	1.998	0.372	8,428	2.075	5,161
DO222138 SPC	2/22/00	11:46p	0.013	7,541	1.997	0.372	8,413	2.066	5,183
DO222139 SPC	2/22/00	11:50p	0.014	7,630	2.02	0.372	8,428	2.1	5,160
DO222140 SPC	2/22/00	11:55p	0.013	7,476	2.054	0.373	8,362	2.106	5,109
DO222141 SPC	2/22/00	11:59p	0.016	7,484	2.088	0.374	8,357	2.081	5,057
DO222142 SPC	2/23/00	12:04a	0.014	7,373	2.087	0.373	8,348	2.077	5,090
DO222143 SPC	2/23/00	12:08a	0.013	7,395	2.051	0.374	8,322	2.08	5,058
DO222144 SPC	2/23/00	12:13a	0.014	7,548	2.088	0.373	8,388	2.066	5,097
DO222145 SPC	2/23/00	12:18a	0.016	7,582	2.087	0.373	8,396	2.094	5,098
DO222146 SPC	2/23/00	12:22a	0.016	7,505	2.078	0.373	8,389	2.133	5,106
DO222147 SPC	2/23/00	12:27a	0.015	7,517	2.081	0.374	8,374	2.112	5,139
DO222148 SPC	2/23/00	12:31a	0.015	7,398	2.084	0.374	8,358	2.094	5,074
DO222149 SPC	2/23/00	12:36a	0.015	7,491	2.066	0.374	8,384	2.201	5,097
DO222150 SPC	2/23/00	12:40a	0.015	7,645	2.078	0.374	8,427	2.321	5,152
DO222151 SPC	2/23/00	12:45a	0.014	7,537	2.107	0.373	8,449	2.408	5,155

C-51

Table C-5. (Continued)

Data Collection			Quantification Method Concentrations in ppm						
File	Date	Time	Olin Mercury Plant		Olin 2		Olin 3		
			sulfur hexafluoride	water	carbon monoxide	nitrous oxide	water	methane	Water
DO222152 SPC	2/23/00	12:49a	0.015	7,399	2.065	0.373	8,356	2.407	5,072
DO222153 SPC	2/23/00	12:54a	0.015	7,528	2.066	0.373	8,432	2.454	5,140
DO222154 SPC	2/23/00	12:59a	0.015	7,404	2.083	0.373	8,352	2.293	5,029
DO222155 SPC	2/23/00	1:03a	0.015	7,388	2.073	0.375	8,255	2.126	4,989
DO222156 SPC	2/23/00	1:08a	0.017	7,493	2.077	0.374	8,356	2.12	5,105
DO222157 SPC	2/23/00	1:12a	0.017	7,450	2.083	0.374	8,353	2.123	5,104
DO222158 SPC	2/23/00	1:17a	0.017	7,486	2.104	0.375	8,365	2.172	5,123
DO222159 SPC	2/23/00	1:21a	0.017	7,636	2.086	0.374	8,480	2.15	5,220
DO222160 SPC	2/23/00	1:26a	0.019	7,661	2.124	0.375	8,518	2.106	5,263
DO222161 SPC	2/23/00	1:30a	0.019	7,644	2.146	0.377	8,497	2.105	5,203
DO222162 SPC	2/23/00	1:35a	0.02	7,503	2.165	0.377	8,414	2.117	5,099
DO222163 SPC	2/23/00	1:40a	0.019	7,505	2.196	0.378	8,380	2.136	5,074
DO222164 SPC	2/23/00	1:44a	0.02	7,589	2.257	0.377	8,437	2.202	5,078
DO222165 SPC	2/23/00	1:49a	0.021	7,676	2.361	0.378	8,474	2.525	5,139
DO222166 SPC	2/23/00	1:53a	0.017	7,686	2.246	0.377	8,521	2.413	5,168
DO222167 SPC	2/23/00	1:58a	0.016	7,729	2.213	0.377	8,541	2.377	5,202
DO222168 SPC	2/23/00	2:02a	0.019	7,730	2.206	0.377	8,519	2.38	5,226
DO222169 SPC	2/23/00	2:07a	0.018	7,700	2.207	0.378	8,531	2.276	5,250
DO222170 SPC	2/23/00	2:12a	0.017	7,632	2.201	0.378	8,452	2.259	5,158
DO222171 SPC	2/23/00	2:16a	0.018	7,562	2.268	0.379	8,391	2.387	5,054
DO222172 SPC	2/23/00	2:21a	0.019	7,539	2.239	0.379	8,369	2.338	5,055
DO222173 SPC	2/23/00	2:25a	0.02	7,489	2.256	0.379	8,394	2.347	5,071
DO222174 SPC	2/23/00	2:30a	0.021	7,531	2.259	0.379	8,361	2.414	5,070
DO222175 SPC	2/23/00	2:34a	0.019	7,422	2.261	0.38	8,348	2.411	5,019
DO222176 SPC	2/23/00	2:39a	0.02	7,431	2.272	0.38	8,357	2.499	5,021
DO222177 SPC	2/23/00	2:43a	0.02	7,468	2.277	0.38	8,367	2.571	5,050
DO222178 SPC	2/23/00	2:48a	0.019	7,493	2.25	0.38	8,366	2.595	5,107
DO222179 SPC	2/23/00	2:53a	0.02	7,480	2.297	0.381	8,355	2.602	5,090
DO222180 SPC	2/23/00	2:57a	0.02	7,501	2.279	0.381	8,367	2.542	5,051
DO222181 SPC	2/23/00	3:02a	0.021	7,436	2.249	0.381	8,354	2.461	5,065

Table C-5. (Continued)

Data Collection			Quantification Method Concentrations in ppm						
File	Date	Time	Olin Mercury Plant		Olin 2		Olin 3		
			sulfur hexafluoride	water	carbon monoxide	nitrous oxide	water	methane	Water
DO222182 SPC	2/23/00	3:06a	0.02	7,548	2.257	0.38	8,405	2.466	5,129
DO222183 SPC	2/23/00	3:11a	0.019	7,515	2.29	0.382	8,424	2.507	5,104
DO222184 SPC	2/23/00	3:15a	0.019	7,540	2.299	0.383	8,432	2.459	5,112
DO222185 SPC	2/23/00	3:20a	0.018	7,504	2.315	0.383	8,459	2.445	5,104
DO222186 SPC	2/23/00	3:25a	0.019	7,556	2.364	0.384	8,458	2.459	5,092
DO222187 SPC	2/23/00	3:29a	0.02	7,512	2.345	0.385	8,404	2.412	5,078
DO222188 SPC	2/23/00	3:34a	0.02	7,586	2.272	0.384	8,448	2.493	5,165
DO222189 SPC	2/23/00	3:38a	0.019	7,572	2.263	0.384	8,455	2.576	5,156
DO222190 SPC	2/23/00	3:43a	0.02	7,519	2.257	0.385	8,445	2.556	5,103
DO222191 SPC	2/23/00	3:47a	0.018	7,447	2.259	0.385	8,362	2.507	5,034
DO222192 SPC	2/23/00	3:52a	0.019	7,437	2.27	0.385	8,357	2.479	4,981
DO222193 SPC	2/23/00	3:57a	0.022	7,347	2.271	0.387	8,326	2.454	4,995
DO222194 SPC	2/23/00	4:01a	0.022	7,562	2.298	0.39	8,364	2.505	5,047
DO222195 SPC	2/23/00	4:06a	0.024	7,534	2.299	0.391	8,422	2.613	5,149
DO222196 SPC	2/23/00	4:10a	0.022	7,503	2.354	0.39	8,387	2.628	5,104
DO222197 SPC	2/23/00	4:15a	0.022	7,347	2.336	0.391	8,272	2.436	4,919
DO222198 SPC	2/23/00	4:19a	0.022	7,428	2.307	0.392	8,276	2.456	4,973
DO222199 SPC	2/23/00	4:24a	0.022	7,413	2.291	0.393	8,281	2.483	4,968
DO222200 SPC	2/23/00	4:29a	0.023	7,355	2.311	0.394	8,269	2.58	4,962
DO222201 SPC	2/23/00	4:33a	0.026	7,445	2.325	0.396	8,312	2.712	4,995
DO222202 SPC	2/23/00	4:38a	0.024	7,448	2.329	0.394	8,308	2.812	5,015
DO222203 SPC	2/23/00	4:42a	0.024	7,367	2.312	0.396	8,226	2.671	4,903
DO222204 SPC	2/23/00	4:47a	0.023	7,359	2.327	0.395	8,253	2.66	4,966
DO222205 SPC	2/23/00	4:51a	0.025	7,347	2.324	0.395	8,237	2.743	4,892
DO222206 SPC	2/23/00	4:56a	0.024	7,324	2.394	0.395	8,264	2.765	4,950
DO222207 SPC	2/23/00	5:00a	0.025	7,344	2.329	0.395	8,238	2.698	4,903
DO222208 SPC	2/23/00	5:05a	0.023	7,335	2.299	0.397	8,183	2.637	4,871
DO222209 SPC	2/23/00	5:10a	0.022	7,268	2.298	0.396	8,202	2.638	4,901
DO222210 SPC	2/23/00	5:14a	0.023	7,342	2.295	0.396	8,216	2.658	4,877
DO222211 SPC	2/23/00	5:19a	0.023	7,296	2.29	0.395	8,181	2.56	4,856

Table C-5. (Continued)

Data Collection			Quantification Method Concentrations in ppm						
File	Date	Time	Olin Mercury Plant		Olin 2		Olin 3		
			sulfur hexafluoride	water	carbon monoxide	nitrous oxide	water	methane	Water
DO222212 SPC	2/23/00	5:23a	0.023	7,226	2.297	0.395	8,158	2.513	4,821
DO222213 SPC	2/23/00	5:28a	0.024	7,202	2.296	0.395	8,176	2.472	4,871
DO222214 SPC	2/23/00	5:32a	0.023	7,248	2.311	0.396	8,188	2.438	4,864
DO222215 SPC	2/23/00	5:37a	0.023	7,285	2.312	0.396	8,174	2.449	4,859
DO222216 SPC	2/23/00	5:42a	0.026	7,304	2.305	0.394	8,166	2.467	4,869
DO222217 SPC	2/23/00	5:46a	0.026	7,305	2.303	0.396	8,142	2.534	4,783
DO222218 SPC	2/23/00	5:51a	0.024	7,198	2.327	0.394	8,153	2.552	4,825
DO222219 SPC	2/23/00	5:55a	0.025	7,214	2.332	0.392	8,151	2.548	4,851
DO222220 SPC	2/23/00	6:00a	0.025	7,208	2.356	0.391	8,164	2.587	4,822
DO222221 SPC	2/23/00	6:04a	0.025	7,245	2.327	0.389	8,175	2.602	4,847
DO222222 SPC	2/23/00	6:09a	0.025	7,293	2.35	0.388	8,180	2.58	4,882
DO222223 SPC	2/23/00	6:14a	0.025	7,222	2.368	0.389	8,141	2.657	4,810
DO222224 SPC	2/23/00	6:18a	0.025	7,289	2.408	0.391	8,152	2.711	4,845
DO222225 SPC	2/23/00	6:23a	0.027	7,252	2.6	0.391	8,195	2.643	4,822
DO222226 SPC	2/23/00	6:27a	0.024	7,207	2.473	0.391	8,181	2.607	4,734
DO222227 SPC	2/23/00	6:32a	0.024	7,349	2.474	0.392	8,209	2.655	4,804
DO222228 SPC	2/23/00	6:37a	0.026	7,279	2.448	0.391	8,195	2.653	4,846
DO222229 SPC	2/23/00	6:41a	0.028	7,318	2.318	0.39	8,242	2.615	4,951
DO222230 SPC	2/23/00	6:46a	0.025	7,351	2.294	0.391	8,235	2.595	4,929
DO222231 SPC	2/23/00	6:50a	0.025	7,219	2.447	0.392	8,146	2.547	4,771
DO222232 SPC	2/23/00	6:55a	0.025	7,194	2.661	0.395	8,156	2.587	4,781
DO222233 SPC	2/23/00	6:59a	0.024	7,242	2.622	0.395	8,172	2.583	4,817
DO222234 SPC	2/23/00	7:04a	0.025	7,193	2.616	0.396	8,155	2.618	4,794
DO222235 SPC	2/23/00	7:09a	0.025	7,272	2.606	0.397	8,155	2.778	4,785
DO222236 SPC	2/23/00	7:13a	0.025	7,237	2.544	0.394	8,207	3.337	4,810
DO222237 SPC	2/23/00	7:18a	0.028	7,506	2.487	0.391	8,325	3.206	4,960
DO222238 SPC	2/23/00	7:22a	0.026	7,556	2.431	0.388	8,449	2.754	5,088
DO222239 SPC	2/23/00	7:27a	0.024	7,429	2.392	0.387	8,369	2.652	5,018
DO222240 SPC	2/23/00	7:31a	0.028	7,504	2.406	0.386	8,394	2.69	5,064
DO222241 SPC	2/23/00	7:36a	0.027	7,522	2.361	0.385	8,423	2.805	5,164

C-54C-54

Table C-5. (Continued)

Data Collection			Quantification Method Concentrations in ppm						
File	Date	Time	Olin Mercury Plant		Olin 2		Olin 3		
			sulfur hexafluoride	water	carbon monoxide	nitrous oxide	water	methane	Water
DO222242 SPC	2/23/00	7:40a	0.025	7,572	2.347	0.387	8,460	2.854	5,149
DO222243 SPC	2/23/00	7:45a	0.024	7,623	2.318	0.384	8,450	2.787	5,124
DO222244 SPC	2/23/00	7:50a	0.024	7,601	2.315	0.384	8,510	2.758	5,221
DO222245 SPC	2/23/00	7:54a	0.027	7,849	2.398	0.383	8,655	2.765	5,342
DO222246 SPC	2/23/00	7:59a	0.027	7,819	2.604	0.383	8,700	2.832	5,327
DO222247 SPC	2/23/00	8:03a	0.022	7,896	2.648	0.384	8,756	3.025	5,402
DO222248 SPC	2/23/00	8:08a	0.022	7,910	2.806	0.385	8,810	3.041	5,464
DO222249 SPC	2/23/00	8:12a	0.02	7,881	2.681	0.385	8,742	2.961	5,388
DO222250 SPC	2/23/00	8:17a	0.025	7,905	2.644	0.384	8,749	2.976	5,411
DO222251 SPC	2/23/00	8:22a	0.028	7,978	2.614	0.386	8,815	2.986	5,475
DO222252 SPC	2/23/00	8:26a	0.029	8,041	2.605	0.386	8,840	3.023	5,509
DO222253 SPC	2/23/00	8:31a	0.029	7,922	2.599	0.387	8,809	2.966	5,474
DO222254 SPC	2/23/00	8:35a	0.029	8,093	2.581	0.388	8,899	2.883	5,524
DO222255 SPC	2/23/00	8:40a	0.026	8,096	2.581	0.387	8,914	2.776	5,579
DO222256 SPC	2/23/00	8:44a	0.022	8,036	2.559	0.387	8,873	2.73	5,558
DO222257 SPC	2/23/00	8:49a	0.022	8,122	2.541	0.389	8,895	2.708	5,552
DO222258 SPC	2/23/00	8:54a	0.021	8,079	2.518	0.388	8,863	2.718	5,543
DO222259 SPC	2/23/00	8:58a	0.021	8,081	2.494	0.388	8,844	2.743	5,514
DO222260 SPC	2/23/00	9:03a	0.021	7,954	2.451	0.386	8,816	2.711	5,499
DO222261 SPC	2/23/00	9:07a	0.021	8,035	2.429	0.388	8,838	2.692	5,522
DO222262 SPC	2/23/00	9:12a	0.022	8,153	2.407	0.387	8,931	2.68	5,648
DO222263 SPC	2/23/00	9:16a	0.023	8,196	2.377	0.385	8,931	2.553	5,579
DO222264 SPC	2/23/00	9:21a	0.023	7,967	2.249	0.381	8,818	2.323	5,494
DO222265 SPC	2/23/00	9:26a	0.018	7,941	2.279	0.382	8,846	2.259	5,588
DO222266 SPC	2/23/00	9:30a	0.016	8,217	2.157	0.381	8,971	2.214	5,760
DO222267 SPC	2/23/00	9:35a	0.017	8,167	2.14	0.377	9,019	2.197	5,787
DO222268 SPC	2/23/00	9:39a	0.015	8,293	2.111	0.376	9,077	2.174	5,919
DO222269 SPC	2/23/00	9:44a	0.015	8,361	2.136	0.374	9,120	2.161	5,959
DO222270 SPC	2/23/00	9:48a	0.014	8,672	2.116	0.371	9,288	2.146	6,143
DO222271 SPC	2/23/00	9:53a	0.013	8,473	2.099	0.369	9,240	2.118	6,075

C-55
C-55

Table C-5. (Continued)

Data Collection			Quantification Method Concentrations in ppm						
File	Date	Time	Olin Mercury Plant		Olin 2		Olin 3		
			sulfur hexafluoride	water	carbon monoxide	nitrous oxide	water	methane	Water
DO222272 SPC	2/23/00	9:58a	0.013	8,513	2.046	0.367	9,223	2.084	6,040
DO222273 SPC	2/23/00	10:02a	0.01	8,527	2.042	0.366	9,265	2.082	6077

Table C-6.

C-57

Collection			Quantification Method Concentrations in ppm						
File	Date	Time	Olin Mercury Plant		Olin 2		Olin 3		
			sulfur hexafluoride	water	carbon monoxide	nitrous oxide	water	methane	Water
D0223002 SPC	2/23/00	11:16a	0.001	9,238	1.97	0.359	9,774	1.964	6658
D0223003 SPC	2/23/00	11:20a	0.001	9,325	2.013	0.359	9,810	1.956	6,674
D0223004 SPC	2/23/00	11:41a	0.008	9,179	1.994	0.359	9,654	1.941	6,547
D0223005 SPC	2/23/00	11:46a	0.007	9,297	1.957	0.358	9,727	1.956	6,662
D0223006 SPC	2/23/00	11:50a	0.009	9,619	1.957	0.357	9,934	1.969	6,870
D0223007 SPC	2/23/00	11:55a	0.009	9,658	1.949	0.356	9,986	1.97	6,965
D0223008 SPC	2/23/00	11:59a	0.01	9,401	1.952	0.357	9,787	1.969	6,711
D0223009 SPC	2/23/00	12:04p	0.008	9,470	1.968	0.357	9,880	1.977	6,798
D0223010 SPC	2/23/00	12:08p	0.008	9,971	1.974	0.356	10,245	1.999	7,144
D0223011 SPC	2/23/00	12:13p	0.009	10,339	1.96	0.355	10,656	1.997	7,527
D0223012 SPC	2/23/00	12:17p	0.009	10,017	1.935	0.355	10,342	1.964	7,257
D0223013 SPC	2/23/00	12:22p	0.008	10,130	1.932	0.356	10,459	1.986	7,348
D0223014 SPC	2/23/00	12:26p	0.012	10,619	1.929	0.354	10,908	1.997	7,806
D0223015 SPC	2/23/00	12:31p	0.01	10,976	1.956	0.356	11,529	1.998	8,043
D0223016 SPC	2/23/00	12:36p	0.01	11,029	1.947	0.355	11,591	2.016	8,153
D0223017 SPC	2/23/00	12:40p	0.01	10,961	1.951	0.356	11,535	2.021	8,104
D0223018 SPC	2/23/00	12:45p	0.008	10,918	1.947	0.356	11,380	2.008	7,969
D0223019 SPC	2/23/00	12:49p	0.008	10,987	1.946	0.355	11,626	2.018	8,122
D0223020 SPC	2/23/00	12:54p	0.012	11,162	1.964	0.355	11,730	1.978	8,270
D0223021 SPC	2/23/00	12:58p	0.009	11,187	1.968	0.354	11,848	1.977	8,338
D0223022 SPC	2/23/00	1:03p	0.011	11,381	1.944	0.354	11,962	2.164	8,192
D0223023 SPC	2/23/00	1:07p	0.011	11,670	1.946	0.353	12,182	2.039	8,586
D0223024 SPC	2/23/00	1:12p	0.011	11,927	1.952	0.352	12,553	2.09	8,901
D0223025 SPC	2/23/00	1:16p	0.011	11,851	1.936	0.352	12,464	2.016	8,881
D0223026 SPC	2/23/00	1:21p	0.012	11,737	1.935	0.353	12,354	1.996	8,762
D0223027 SPC	2/23/00	1:25p	0.011	11,901	1.934	0.352	12,437	2.007	8,845
D0223028 SPC	2/23/00	1:30p	0.011	12,043	2.153	0.354	12,671	2.026	9,030
D0223029 SPC	2/23/00	1:34p	0.011	12,240	2.484	0.357	12,930	2.01	9,120
D0223030 SPC	2/23/00	1:39p	0.009	12,218	2.632	0.359	12,987	2.02	9,136
D0223031 SPC	2/23/00	1:44p	0.009	12,105	2.372	0.356	12,739	2.043	9,049

Table C-6. (Continued)

Collection			Quantification Method						
			Olin Mercury Plant		Olin 2			Olin 3	
File	Date	Time	sulfur hexafluoride	water	carbon monoxide	nitrous oxide	water	methane	Water
D0223032 SPC	2/23/00	1:48p	0.009	12,175	1.984	0.35	12,772	2.098	9,102
D0223033 SPC	2/23/00	1:53p	0.009	12,481	1.975	0.349	12,896	2.112	9,256
D0223034 SPC	2/23/00	1:57p	0.008	12,394	1.995	0.352	12,870	2.121	9,223
D0223035 SPC	2/23/00	2:02p	0.007	12,465	1.966	0.349	12,886	2.074	9,226
D0223036 SPC	2/23/00	2:06p	0.009	12,668	2.043	0.349	13,166	2.144	9,524
D0223037 SPC	2/23/00	2:11p	0.007	12,560	1.977	0.349	13,108	2.062	9,440
D0223038 SPC	2/23/00	2:15p	0.01	12,763	1.97	0.348	13,234	2.106	9,525
D0223039 SPC	2/23/00	2:20p	0.007	12,940	1.994	0.35	13,365	2.098	9,602
D0223040 SPC	2/23/00	2:24p	0.005	13,053	1.976	0.349	13,580	2.08	9,743
D0223041 SPC	2/23/00	2:29p	0.006	13,183	2.02	0.349	13,959	2.209	9,879
D0223042 SPC	2/23/00	2:33p	0.007	13,154	1.958	0.349	13,867	2.095	9,894
D0223043 SPC	2/23/00	2:38p	0.007	13,383	1.97	0.349	14,135	2.027	10,013
D0223044 SPC	2/23/00	2:42p	0.011	13,565	1.994	0.348	14,322	2.044	10,192
D0223045 SPC	2/23/00	2:47p	0.009	13,615	1.994	0.349	14,380	2.088	10,194
D0223046 SPC	2/23/00	2:51p	0.007	13,288	1.985	0.349	14,163	2.129	10,030
D0223047 SPC	2/23/00	2:56p	0.007	13,567	1.981	0.348	14,323	2.129	10,194
D0223048 SPC	2/23/00	3:00p	0.008	13,677	2.095	0.349	14,465	2.143	10,310
D0223049 SPC	2/23/00	3:05p	0.007	13,799	2.041	0.348	14,606	2.092	10,397
D0223050 SPC	2/23/00	3:10p	0.007	13,790	2.029	0.348	14,635	2.152	10,487
D0223051 SPC	2/23/00	3:14p	0.007	13,792	2.026	0.347	14,502	2.134	10,328
D0223052 SPC	2/23/00	3:19p	0.006	13,705	2.104	0.349	14,428	2.152	10,234
D0223053 SPC	2/23/00	3:23p	0.007	13,643	2.039	0.349	14,485	2.15	10,272
D0223054 SPC	2/23/00	3:28p	0.007	13,536	2.002	0.348	14,371	2.092	10,210
D0223055 SPC	2/23/00	3:32p	0.007	13,604	2.005	0.348	14,329	2.083	10,166
D0223056 SPC	2/23/00	3:37p	0.007	13,748	1.981	0.347	14,592	2.111	10,444
D0223057 SPC	2/23/00	3:41p	0.005	14,130	1.995	0.347	14,844	2.119	10,640
D0223058 SPC	2/23/00	3:46p	0.007	14,296	1.989	0.347	15,115	2.076	10,892
D0223059 SPC	2/23/00	3:50p	0.006	14,326	2.03	0.346	15,135	2.058	10,917
D0223060 SPC	2/23/00	3:55p	0.006	14,230	2.017	0.347	15,043	2.075	10,806
D0223061 SPC	2/23/00	3:59p	0.021	14,266	2.002	0.346	15,109	2.071	10,923

C-58

Table C-6. (Continued)

Collection			Quantification Method Concentrations in ppm						
File	Date	Time	Olin Mercury Plant		Olin 2		Olin 3		
			sulfur hexafluoride	water	carbon monoxide	nitrous oxide	water	methane	Water
D0223062 SPC	2/23/00	4:04p	0.013	14,391	1.992	0.346	15,202	2.123	10,978
D0223063 SPC	2/23/00	4:08p	0.007	14,229	1.988	0.346	14,950	2.195	10,719
D0223064 SPC	2/23/00	4:13p	0.022	14,104	1.984	0.346	15,003	2.032	10,811
D0223065 SPC	2/23/00	4:17p	0.013	14,297	1.986	0.345	15,100	2.107	10,894
D0223066 SPC	2/23/00	4:22p	0.031	14,253	1.993	0.346	15,159	2.205	10,933
D0223067 SPC	2/23/00	4:26p	0.022	14,042	1.983	0.347	14,920	2.064	10,728
D0223068 SPC	2/23/00	4:31p	0.033	14,106	1.985	0.346	15,137	2.127	10,903
D0223069 SPC	2/23/00	4:36p	0.04	14,193	1.979	0.345	15,224	2.119	11,026
D0223070 SPC	2/23/00	4:40p	0.042	14,073	1.969	0.345	15,199	2.136	10,954
D0223071 SPC	2/23/00	4:45p	0.043	14,122	1.967	0.345	15,295	2.198	11,057
D0223072 SPC	2/23/00	4:49p	0.042	14,108	1.97	0.344	15,264	2.176	11,075
D0223073 SPC	2/23/00	4:54p	0.042	14,331	1.938	0.341	15,239	2.325	11,044
D0223074 SPC	2/23/00	4:58p	0.042	14,184	1.942	0.346	15,276	2.37	11,125
D0223075 SPC	2/23/00	5:03p	0.042	14,396	1.929	0.336	15,149	2.195	10,943
D0223076 SPC	2/23/00	5:07p	0.044	14,554	1.962	0.337	15,278	2.336	11,146
D0223077 SPC	2/23/00	5:12p	0.042	14,474	1.921	0.336	15,231	2.274	11,081
D0223078 SPC	2/23/00	5:16p	0.042	14,627	1.92	0.338	15,298	2.071	11,205
D0223079 SPC	2/23/00	5:21p	0.045	14,633	1.924	0.338	15,419	2.188	11,265
D0223080 SPC	2/23/00	5:25p	0.044	14,478	1.923	0.337	15,191	2.177	11,123
D0223081 SPC	2/23/00	5:30p	0.043	14,474	1.924	0.338	15,131	2.138	11,017
D0223082 SPC	2/23/00	5:35p	0.038	14,699	1.942	0.337	15,261	2.2	11,054
D0223083 SPC	2/23/00	5:39p	0.041	14,522	1.933	0.338	15,234	2.043	11,102
D0223084 SPC	2/23/00	5:44p	0.043	14,489	1.923	0.338	15,279	2.216	11,155
D0223085 SPC	2/23/00	5:48p	0.043	14,573	1.932	0.338	15,312	2.248	11,194
D0223086 SPC	2/23/00	5:53p	0.046	14,410	1.939	0.339	15,231	2.172	11,147
D0223087 SPC	2/23/00	5:57p	0.043	14,811	1.93	0.338	15,507	2.143	11,370
D0223088 SPC	2/23/00	6:02p	0.044	14,769	1.92	0.338	15,533	1.962	11,428
D0223089 SPC	2/23/00	6:06p	0.047	15,053	1.914	0.338	15,640	1.927	11,570
D0223090 SPC	2/23/00	6:11p	0.048	15,008	1.914	0.34	15,658	1.922	11,606
D0223091 SPC	2/23/00	6:15p	0.042	14,905	1.911	0.339	15,513	1.898	11,498

C-59

Table C-6. (Continued)

Collection			Quantification Method Concentrations in ppm						
File	Date	Time	Olin Mercury Plant		Olin 2		Olin 3		
			sulfur hexafluoride	water	carbon monoxide	nitrous oxide	water	methane	Water
D0223092 SPC	2/23/00	6:20p	0.047	14,790	1.919	0.339	15,531	1.893	11,490
D0223093 SPC	2/23/00	6:25p	0.047	14,677	1.924	0.339	15,496	1.912	11,496
D0223094 SPC	2/23/00	6:29p	0.045	14,700	1.925	0.341	15,446	1.9	11,388
D0223095 SPC	2/23/00	6:34p	0.047	14,595	1.926	0.341	15,405	1.916	11,397
D0223096 SPC	2/23/00	6:38p	0.044	14,701	1.922	0.341	15,445	1.915	11,405
D0223097 SPC	2/23/00	6:43p	0.044	14,835	1.923	0.342	15,425	1.919	11,425
D0223098 SPC	2/23/00	6:47p	0.048	14,598	1.922	0.341	15,396	1.917	11,450
D0223099 SPC	2/23/00	6:52p	0.049	14,631	1.924	0.341	15,443	1.933	11,507
D0223100 SPC	2/23/00	6:56p	0.047	14,542	1.924	0.342	15,345	1.922	11,416
D0223101 SPC	2/23/00	7:01p	0.045	14,634	1.927	0.342	15,289	1.903	11,333
D0223102 SPC	2/23/00	7:05p	0.05	14,563	1.931	0.343	15,293	1.908	11,368
D0223103 SPC	2/23/00	7:10p	0.049	14,521	1.934	0.345	15,297	1.91	11,332
D0223104 SPC	2/23/00	7:15p	0.05	14,648	2.029	0.344	15,444	1.933	11,520
D0223105 SPC	2/23/00	7:19p	0.05	14,643	2.035	0.345	15,402	1.945	11,432
D0223106 SPC	2/23/00	7:24p	0.045	14,556	1.977	0.345	15,232	1.925	11,287
D0223107 SPC	2/23/00	7:28p	0.047	14,701	1.959	0.344	15,304	1.927	11,384
D0223108 SPC	2/23/00	7:33p	0.046	14,436	1.96	0.344	15,129	1.912	11,167
D0223109 SPC	2/23/00	7:37p	0.048	14,407	1.953	0.344	15,137	1.922	11,166
D0223110 SPC	2/23/00	7:42p	0.049	14,485	1.952	0.344	15,280	1.95	11,361
D0223111 SPC	2/23/00	7:46p	0.05	14,512	1.954	0.344	15,451	1.95	11,532
D0223112 SPC	2/23/00	7:51p	0.049	14,672	1.95	0.344	15,535	1.989	11,602
D0223113 SPC	2/23/00	7:55p	0.047	14,681	1.946	0.345	15,490	2.088	11,538
D0223114 SPC	2/23/00	8:00p	0.046	14,815	1.948	0.344	15,542	1.964	11,637
D0223115 SPC	2/23/00	8:04p	0.046	14,971	1.954	0.344	15,589	1.963	11,697
D0223116 SPC	2/23/00	8:09p	0.048	14,673	1.983	0.345	15,407	1.904	11,468
D0223117 SPC	2/23/00	8:14p	0.047	14,860	1.99	0.345	15,548	1.91	11,630
D0223118 SPC	2/23/00	8:18p	0.045	15,346	1.97	0.344	16,104	2.115	12,064
D0223119 SPC	2/23/00	8:23p	0.05	15,366	1.984	0.344	16,400	2.527	12,153
D0223120 SPC	2/23/00	8:27p	0.047	15,645	1.976	0.345	16,735	2.948	12,349
D0223121 SPC	2/23/00	8:32p	0.046	15,748	1.968	0.345	16,797	2.819	12,456

C-60

Table C-6. (Continued)

Collection			Quantification Method Concentrations in ppm						
File	Date	Time	Olin Mercury Plant		Olin 2		Olin 3		
			sulfur hexafluoride	water	carbon monoxide	nitrous oxide	water	methane	Water
D0223122 SPC	2/23/00	8:36p	0.046	15,666	1.971	0.346	16,667	2.819	12,346
D0223123 SPC	2/23/00	8:41p	0.048	15,625	1.975	0.346	16,627	2.394	12,268
D0223124 SPC	2/23/00	8:45p	0.048	15,581	2.075	0.345	16,675	2.273	12,243
D0223125 SPC	2/23/00	8:50p	0.047	15,578	1.974	0.344	16,581	2.118	12,219
D0223126 SPC	2/23/00	8:54p	0.051	15,437	1.978	0.344	16,468	2.157	12,191
D0223127 SPC	2/23/00	8:59p	0.048	15,276	1.949	0.345	16,144	2.027	12,086
D0223128 SPC	2/23/00	9:04p	0.049	15,058	1.941	0.345	15,794	2.131	11,833
D0223129 SPC	2/23/00	9:08p	0.05	14,860	1.939	0.347	15,518	2.121	11,644
D0223130 SPC	2/23/00	9:13p	0.051	14,945	1.947	0.347	15,711	2.088	11,782
D0223131 SPC	2/23/00	9:17p	0.049	15,025	1.956	0.347	15,871	2.339	11,883
D0223132 SPC	2/23/00	9:22p	0.049	15,132	1.956	0.347	15,843	2.842	11,912
D0223133 SPC	2/23/00	9:26p	0.052	14,920	1.95	0.346	15,655	2.726	11,785
D0223134 SPC	2/23/00	9:31p	0.048	14,992	1.959	0.347	15,642	2.861	11,723
D0223135 SPC	2/23/00	9:35p	0.052	15,125	1.962	0.347	15,749	2.855	11,780
D0223136 SPC	2/23/00	9:40p	0.048	15,330	1.965	0.345	16,408	3.373	12,225
D0223137 SPC	2/23/00	9:44p	0.047	15,433	1.981	0.347	16,718	4.308	12,305
D0223138 SPC	2/23/00	9:49p	0.047	15,652	1.976	0.348	16,723	4.543	12,368
D0223139 SPC	2/23/00	9:53p	0.048	15,233	1.977	0.348	16,639	4.687	12,233
D0223140 SPC	2/23/00	9:58p	0.046	15,058	1.951	0.347	15,920	3.864	11,951
D0223141 SPC	2/23/00	10:02p	0.049	14,884	1.953	0.349	15,606	3.166	11,689
D0223142 SPC	2/23/00	10:07p	0.05	14,545	2.02	0.35	15,574	2.897	11,615
D0223143 SPC	2/23/00	10:12p	0.05	14,881	1.963	0.349	15,662	2.736	11,772
D0223144 SPC	2/23/00	10:16p	0.047	15,291	1.975	0.347	16,344	2.728	12,180
D0223145 SPC	2/23/00	10:21p	0.05	15,470	1.994	0.348	16,746	2.443	12,452
D0223146 SPC	2/23/00	10:25p	0.049	15,849	1.988	0.349	16,625	2.337	12,371
D0223147 SPC	2/23/00	10:30p	0.049	15,336	1.982	0.348	16,395	2.482	12,112
D0223148 SPC	2/23/00	10:34p	0.053	15,443	1.989	0.349	16,299	2.4	12,093
D0223149 SPC	2/23/00	10:39p	0.051	15,137	1.982	0.348	16,063	2.253	12,092
D0223150 SPC	2/23/00	10:43p	0.053	15,502	2.028	0.35	16,704	2.221	12,454
D0223151 SPC	2/23/00	10:48p	0.051	15,199	2.043	0.349	16,039	2.351	12,080

C-61

Table C-6. (Continued)

Collection			Quantification Method Concentrations in ppm						
File	Date	Time	Olin Mercury Plant		Olin 2		Olin 3		
			sulfur hexafluoride	water	carbon monoxide	nitrous oxide	water	methane	Water
D0223152 SPC	2/23/00	10:52p	0.053	14,677	1.956	0.349	15,627	2.34	11,858
D0223153 SPC	2/23/00	10:57p	0.056	15,099	1.973	0.349	15,735	2.371	11,883
D0223154 SPC	2/23/00	11:02p	0.057	14,763	1.97	0.349	15,482	2.449	11,649
D0223155 SPC	2/23/00	11:06p	0.055	14,339	1.984	0.35	15,504	2.358	11,674
D0223156 SPC	2/23/00	11:11p	0.057	14,439	2.059	0.351	15,312	2.353	11,489
D0223157 SPC	2/23/00	11:15p	0.053	14,661	1.971	0.35	15,546	2.414	11,703
D0223158 SPC	2/23/00	11:20p	0.053	14,954	1.964	0.351	15,375	2.487	11,563
D0223159 SPC	2/23/00	11:24p	0.056	14,421	1.966	0.351	15,281	2.53	11,487
D0223160 SPC	2/23/00	11:29p	0.054	14,360	1.985	0.352	15,070	2.444	11,253
D0223161 SPC	2/23/00	11:33p	0.053	14,351	2.032	0.354	15,136	2.28	11,302
D0223162 SPC	2/23/00	11:38p	0.057	14,340	1.998	0.353	15,205	2.299	11,344
D0223163 SPC	2/23/00	11:42p	0.056	14,405	1.991	0.353	15,212	2.329	11,403
D0223164 SPC	2/23/00	11:47p	0.053	14,459	2.013	0.353	15,325	2.376	11,501
D0223165 SPC	2/23/00	11:52p	0.056	14,342	2.031	0.353	15,192	2.316	11,345
D0223166 SPC	2/23/00	11:56p	0.051	14,395	2.061	0.354	15,102	2.251	11,191
D0223167 SPC	2/24/00	12:01a	0.052	14,513	2.006	0.353	15,287	2.308	11,557
D0223168 SPC	2/24/00	12:05a	0.052	14,858	2.009	0.353	15,595	2.296	11,826
D0223169 SPC	2/24/00	12:10a	0.054	14,867	2.006	0.353	15,776	2.214	11,966
D0223170 SPC	2/24/00	12:14a	0.051	14,728	1.992	0.353	15,569	2.217	11,804
D0223171 SPC	2/24/00	12:19a	0.051	14,809	2.001	0.354	15,532	2.23	11,759
D0223172 SPC	2/24/00	12:23a	0.053	14,497	1.991	0.354	15,337	2.149	11,510
D0223173 SPC	2/24/00	12:28a	0.053	14,406	1.987	0.354	15,237	2.133	11,484
D0223174 SPC	2/24/00	12:32a	0.055	14,358	1.995	0.354	15,295	2.135	11,554
D0223175 SPC	2/24/00	12:37a	0.056	14,206	1.992	0.354	15,200	2.127	11,465
D0223176 SPC	2/24/00	12:42a	0.053	14,262	1.991	0.355	15,033	2.089	11,291
D0223177 SPC	2/24/00	12:46a	0.051	13,767	1.984	0.355	14,593	2.094	10,880
D0223178 SPC	2/24/00	12:51a	0.049	13,807	1.976	0.356	14,460	2.088	10,853
D0223179 SPC	2/24/00	12:55a	0.052	14,037	1.991	0.356	14,664	2.117	10,932
D0223180 SPC	2/24/00	1:00a	0.052	13,745	1.986	0.357	14,545	2.17	10,827
D0223181 SPC	2/24/00	1:04a	0.044	13,659	1.98	0.356	14,447	2.246	10,800

C-62

Table C-6. (Continued)

Collection			Quantification Method Concentrations in ppm						
File	Date	Time	Olin Mercury Plant		Olin 2		Olin 3		
			sulfur hexafluoride	water	carbon monoxide	nitrous oxide	water	methane	Water
D0223182 SPC	2/24/00	1:09a	0.04	14,088	2	0.356	14,767	2.151	11,042
D0223183 SPC	2/24/00	1:13a	0.043	13,929	2.004	0.357	14,648	2.129	10,951
D0223184 SPC	2/24/00	1:18a	0.046	13,854	2.029	0.356	14,561	2.188	10,771
D0223185 SPC	2/24/00	1:22a	0.047	13,717	2.019	0.356	14,504	2.233	10,828
D0223186 SPC	2/24/00	1:27a	0.042	13,822	2.036	0.357	14,543	2.355	10,776
D0223187 SPC	2/24/00	1:32a	0.039	13,784	2.028	0.358	14,448	2.316	10,609
D0223188 SPC	2/24/00	1:36a	0.037	13,780	2.021	0.358	14,383	2.142	10,695
D0223189 SPC	2/24/00	1:41a	0.049	13,831	2.047	0.357	14,665	2.207	10,829
D0223190 SPC	2/24/00	1:45a	0.054	14,353	2.082	0.356	14,984	2.244	11,220
D0223191 SPC	2/24/00	1:50a	0.05	13,949	2.084	0.356	14,827	2.202	11,017
D0223192 SPC	2/24/00	1:54a	0.052	14,076	2.057	0.356	14,797	2.044	11,089
D0223193 SPC	2/24/00	1:59a	0.056	13,653	2.033	0.357	14,528	2.121	10,831
D0223194 SPC	2/24/00	2:03a	0.057	13,572	2.049	0.358	14,468	2.278	10,677
D0223195 SPC	2/24/00	2:08a	0.053	13,372	2.051	0.358	14,374	2.281	10,660
D0223196 SPC	2/24/00	2:13a	0.047	13,537	2.043	0.358	14,379	2.289	10,706
D0223197 SPC	2/24/00	2:17a	0.051	13,672	2.057	0.358	14,334	2.331	10,557
D0223198 SPC	2/24/00	2:22a	0.054	13,203	2.042	0.357	14,063	2.353	10,394
D0223199 SPC	2/24/00	2:26a	0.056	13,386	2.07	0.358	14,170	2.385	10,427
D0223200 SPC	2/24/00	2:31a	0.054	13,470	2.082	0.359	14,311	2.349	10,554
D0223201 SPC	2/24/00	2:35a	0.052	13,455	2.09	0.358	14,214	2.338	10,447
D0223202 SPC	2/24/00	2:40a	0.061	13,676	2.167	0.36	14,546	2.731	10,713
D0223203 SPC	2/24/00	2:44a	0.058	13,691	2.137	0.359	14,521	2.609	10,787
D0223204 SPC	2/24/00	2:49a	0.057	13,368	2.123	0.359	14,304	2.453	10,507
D0223205 SPC	2/24/00	2:53a	0.056	13,247	2.124	0.359	14,237	2.38	10,487
D0223206 SPC	2/24/00	2:58a	0.056	13,484	2.143	0.36	14,272	2.638	10,549
D0223207 SPC	2/24/00	3:03a	0.053	13,536	2.21	0.36	14,279	2.569	10,420
D0223208 SPC	2/24/00	3:07a	0.054	13,419	2.171	0.36	14,383	2.586	10,517
D0223209 SPC	2/24/00	3:12a	0.056	13,314	2.116	0.359	14,133	2.472	10,363
D0223210 SPC	2/24/00	3:16a	0.055	13,190	2.13	0.359	14,160	2.403	10,387
D0223211 SPC	2/24/00	3:21a	0.054	13,197	2.133	0.359	14,106	2.346	10,324

Table C-6. (Continued)

Collection			Quantification Method Concentrations in ppm						
File	Date	Time	Olin Mercury Plant		Olin 2		Olin 3		
			sulfur hexafluoride	water	carbon monoxide	nitrous oxide	water	methane	Water
D0223212 SPC	2/24/00	3:25a	0.055	13,585	2.181	0.36	14,487	2.444	10,661
D0223213 SPC	2/24/00	3:30a	0.058	13,606	2.184	0.36	14,513	2.749	10,799
D0223214 SPC	2/24/00	3:34a	0.051	13,298	2.159	0.36	14,141	2.404	10,342
D0223215 SPC	2/24/00	3:39a	0.054	13,166	2.153	0.36	14,097	2.271	10,299
D0223216 SPC	2/24/00	3:43a	0.058	13,278	2.211	0.361	14,224	2.333	10,419
D0223217 SPC	2/24/00	3:48a	0.056	13,229	2.17	0.359	14,232	2.256	10,445
D0223218 SPC	2/24/00	3:53a	0.055	13,125	2.155	0.36	14,057	2.179	10,337
D0223219 SPC	2/24/00	3:57a	0.057	13,079	2.149	0.361	13,690	2.144	10,174
D0223220 SPC	2/24/00	4:02a	0.056	13,433	2.167	0.36	14,208	2.181	10,452
D0223221 SPC	2/24/00	4:06a	0.054	13,433	2.183	0.36	14,296	2.175	10,535
D0223222 SPC	2/24/00	4:11a	0.056	13,517	2.18	0.361	14,356	2.184	10,604
D0223223 SPC	2/24/00	4:15a	0.057	13,541	2.187	0.361	14,390	2.224	10,596
D0223224 SPC	2/24/00	4:20a	0.056	13,608	2.189	0.361	14,501	2.252	10,715
D0223225 SPC	2/24/00	4:24a	0.057	13,646	2.207	0.362	14,535	2.306	10,762
D0223226 SPC	2/24/00	4:29a	0.055	13,799	2.222	0.364	14,600	2.435	10,764
D0223227 SPC	2/24/00	4:34a	0.053	13,739	2.242	0.364	14,518	2.531	10,691
D0223228 SPC	2/24/00	4:38a	0.055	13,728	2.281	0.365	14,526	2.801	10,660
D0223229 SPC	2/24/00	4:43a	0.057	13,218	2.244	0.364	14,145	3.004	10,367
D0223230 SPC	2/24/00	4:47a	0.058	13,024	2.212	0.363	13,689	2.928	10,122
D0223231 SPC	2/24/00	4:52a	0.058	12,734	2.214	0.363	13,481	2.762	10,067
D0223232 SPC	2/24/00	4:56a	0.055	12,787	2.374	0.364	13,276	2.626	9,843
D0223233 SPC	2/24/00	5:01a	0.054	12,876	2.269	0.363	13,308	2.449	9,852
D0223234 SPC	2/24/00	5:05a	0.05	13,317	2.251	0.363	13,785	2.519	10,135
D0223235 SPC	2/24/00	5:10a	0.05	13,184	2.269	0.364	13,801	2.643	10,169
D0223236 SPC	2/24/00	5:15a	0.051	13,053	2.346	0.366	13,721	3.057	10,108
D0223237 SPC	2/24/00	5:19a	0.052	12,703	2.291	0.365	13,221	2.769	9,783
D0223238 SPC	2/24/00	5:24a	0.055	12,807	2.33	0.369	13,484	3.013	10,003
D0223239 SPC	2/24/00	5:28a	0.052	12,793	2.342	0.373	13,428	3.064	9,989
D0223240 SPC	2/24/00	5:33a	0.052	12,875	2.414	0.372	13,399	3.203	9,866
D0223241 SPC	2/24/00	5:37a	0.05	12,866	2.398	0.374	13,325	3.439	9,790

C-64

C-64

Table C-6. (Continued)

Collection			Quantification Method Concentrations in ppm						
File	Date	Time	Olin Mercury Plant		Olin 2		Olin 3		
			sulfur hexafluoride	water	carbon monoxide	nitrous oxide	water	methane	Water
D0223242 SPC	2/24/00	5:42a	0.05	13,136	2.385	0.377	13,687	3.57	10,011
D0223243 SPC	2/24/00	5:46a	0.052	13,105	2.404	0.371	13,888	3.21	10,178
D0223244 SPC	2/24/00	5:51a	0.052	13,313	2.441	0.368	14,192	3.022	10,381
D0223245 SPC	2/24/00	5:56a	0.052	13,446	2.45	0.367	14,303	2.904	10,453
D0223246 SPC	2/24/00	6:00a	0.052	13,278	2.428	0.367	14,134	2.958	10,296
D0223247 SPC	2/24/00	6:05a	0.052	13,073	2.422	0.367	13,816	2.939	10,072
D0223248 SPC	2/24/00	6:09a	0.052	13,147	2.422	0.367	13,944	2.893	10,232
D0223249 SPC	2/24/00	6:14a	0.055	13,038	2.425	0.367	13,957	2.786	10,195
D0223250 SPC	2/24/00	6:18a	0.056	13,113	2.754	0.372	14,120	2.69	10,160
D0223251 SPC	2/24/00	6:23a	0.056	12,903	2.624	0.372	13,773	2.65	10,014
D0223252 SPC	2/24/00	6:28a	0.057	12,964	2.456	0.373	13,833	2.653	10,190
D0223253 SPC	2/24/00	6:32a	0.056	13,105	2.396	0.373	13,930	2.741	10,201
D0223254 SPC	2/24/00	6:37a	0.054	13,133	2.376	0.373	14,091	2.798	10,218
D0223255 SPC	2/24/00	6:41a	0.054	13,430	2.33	0.369	14,234	3.79	10,354
D0223256 SPC	2/24/00	6:46a	0.051	13,325	2.325	0.369	14,169	3.842	10,285
D0223257 SPC	2/24/00	6:50a	0.05	13,030	2.445	0.373	13,717	3.127	10,032
D0223258 SPC	2/24/00	6:55a	0.053	13,045	2.612	0.374	13,662	3.054	9,943
D0223259 SPC	2/24/00	6:59a	0.053	12,856	2.557	0.374	13,518	3.168	9,878
D0223260 SPC	2/24/00	7:04a	0.053	12,698	2.559	0.374	13,345	3.185	9,819
D0223261 SPC	2/24/00	7:09a	0.054	12,837	2.609	0.374	13,498	3.192	9,906
D0223262 SPC	2/24/00	7:13a	0.053	13,082	2.58	0.374	13,719	3.142	10,021
D0223263 SPC	2/24/00	7:18a	0.053	13,072	2.469	0.374	13,640	3.103	10,025
D0223264 SPC	2/24/00	7:22a	0.052	13,320	2.486	0.373	14,172	3.099	10,284
D0223265 SPC	2/24/00	7:27a	0.05	13,837	2.598	0.373	14,765	3.157	10,810
D0223266 SPC	2/24/00	7:31a	0.048	13,934	2.561	0.371	14,833	3.13	10,931
D0223267 SPC	2/24/00	7:36a	0.046	13,944	2.47	0.372	14,856	2.933	10,928
D0223268 SPC	2/24/00	7:40a	0.037	14,307	2.417	0.373	15,058	2.846	11,183
D0223269 SPC	2/24/00	7:45a	0.042	13,968	2.388	0.374	14,756	2.81	10,913
D0223270 SPC	2/24/00	7:50a	0.048	13,717	2.377	0.374	14,632	2.87	10,782
D0223271 SPC	2/24/00	7:54a	0.051	13,993	2.46	0.375	14,955	3.048	11,070

C-65

C-65

Table C-6. (Continued)

Collection			Quantification Method Concentrations in ppm						
File	Date	Time	Olin Mercury Plant		Olin 2		Olin 3		
			sulfur hexafluoride	water	carbon monoxide	nitrous oxide	water	methane	Water
D0223272 SPC	2/24/00	7:59a	0.05	14,363	2.495	0.376	15,198	3.316	11,323
D0223273 SPC	2/24/00	8:03a	0.054	14,307	2.449	0.375	15,150	3.259	11,313
D0223274 SPC	2/24/00	8:08a	0.057	13,909	2.538	0.374	14,956	3.169	11,055
D0223275 SPC	2/24/00	8:12a	0.054	13,759	2.569	0.376	14,752	3.3	10,791
D0223276 SPC	2/24/00	8:17a	0.053	13,717	2.646	0.377	14,722	3.187	10,771
D0223277 SPC	2/24/00	8:22a	0.051	13,752	2.493	0.374	14,553	3.155	10,704
D0223278 SPC	2/24/00	8:26a	0.051	13,613	2.497	0.374	14,540	3.19	10,674
D0223279 SPC	2/24/00	8:31a	0.052	13,542	2.49	0.373	14,519	3.154	10,664
D0223280 SPC	2/24/00	8:35a	0.052	13,778	2.474	0.374	14,669	3.098	10,825
D0223281 SPC	2/24/00	8:40a	0.05	13,888	2.459	0.375	14,728	3.138	10,807
D0223282 SPC	2/24/00	8:44a	0.048	14,081	2.483	0.384	14,915	3.2	10,961
D0223283 SPC	2/24/00	8:49a	0.052	14,019	2.521	0.393	15,011	3.186	11092

Table C-7.

Data Collection Information			Quantification Method Concentrations in ppm						
			Olin Mercury Plant		Olin 2		Olin 3		
File	Date	Time	sulfur hexafluoride	water	carbon monoxide	nitrous oxide	water	methane	Water
D0224002 SPC	2/24/00	9:40a	0.047	15684	2.243	0.356	17442	2.367	13145
D0224003 SPC	2/24/00	9:45a	0.046	15,897	2.199	0.354	17,643	2.251	13,343
D0224004 SPC	2/24/00	9:53a	0.043	15,881	2.15	0.353	17,750	2.175	13,474
D0224005 SPC	2/24/00	9:57a	0.042	16,189	2.233	0.354	17,932	2.161	13,597
D0224006 SPC	2/24/00	10:02a	0.04	16,048	2.176	0.354	17,881	2.213	13,606
D0224007 SPC	2/24/00	10:06a	0.039	16,226	2.161	0.353	17,883	2.255	13,590
D0224008 SPC	2/24/00	10:11a	0.04	16,141	2.202	0.354	17,900	2.325	13,558
D0224009 SPC	2/24/00	10:15a	0.044	16,247	2.148	0.353	17,990	2.492	13,634
D0224010 SPC	2/24/00	10:20a	0.04	16,365	2.143	0.352	17,960	2.557	13,601
D0224011 SPC	2/24/00	10:24a	0.039	16,341	2.16	0.352	17,912	2.624	13,566
D0224012 SPC	2/24/00	10:29a	0.038	16,208	2.166	0.352	17,943	2.541	13,589
D0224013 SPC	2/24/00	10:35a	0.042	16,344	2.113	0.349	18,123	2.415	13,782
D0224014 SPC	2/24/00	10:40a	0.043	16,463	2.159	0.349	18,162	2.37	13,768
D0224015 SPC	2/24/00	10:44a	0.042	16,534	2.173	0.35	18,184	2.358	13,761
D0224016 SPC	2/24/00	10:49a	0.041	16,505	2.114	0.349	18,180	2.335	13,822
D0224017 SPC	2/24/00	10:53a	0.044	16,423	2.116	0.348	18,195	2.322	13,864
D0224018 SPC	2/24/00	10:58a	0.042	16,568	2.104	0.347	18,282	2.322	13,914
D0224019 SPC	2/24/00	11:02a	0.04	16,659	2.097	0.346	18,307	2.298	13,991
D0224020 SPC	2/24/00	11:07a	0.042	16,714	2.09	0.345	18,417	2.362	13,986
D0224021 SPC	2/24/00	11:11a	0.044	16,709	2.101	0.345	18,526	2.357	14,006
D0224022 SPC	2/24/00	11:16a	0.041	16,705	2.094	0.344	18,386	2.25	13,960
D0224023 SPC	2/24/00	11:21a	0.043	16,792	2.079	0.343	18,674	2.191	14,041
D0224024 SPC	2/24/00	11:25a	0.043	16,971	2.074	0.342	18,803	2.248	14,110
D0224025 SPC	2/24/00	11:30a	0.039	17,142	2.039	0.34	18,950	2.216	14,190
D0224026 SPC	2/24/00	11:34a	0.04	17,046	2.018	0.34	18,814	2.087	14,062
D0224027 SPC	2/24/00	11:39a	0.039	16,924	2.009	0.339	18,542	2.058	13,982
D0224028 SPC	2/24/00	11:43a	0.039	16,868	1.994	0.339	18,494	2.05	13,987
D0224029 SPC	2/24/00	11:48a	0.033	16,921	2	0.34	18,542	2.175	14,013
D0224030 SPC	2/24/00	11:52a	0.042	16,964	2.006	0.338	18,579	2.129	14,025
D0224031 SPC	2/24/00	11:57a	0.035	16,804	1.994	0.339	18,230	2.157	13,781

C-67

Table C-7. (Continued)

Data Collection Information			Quantification Method Concentrations in ppm						
File	Date	Time	Olin Mercury Plant		Olin 2		Olin 3		
			sulfur hexafluoride	water	carbon monoxide	nitrous oxide	water	methane	Water
D0224032 SPC	2/24/00	12:01p	0.038	16,839	1.985	0.338	18,467	2.222	13,975
D0224033 SPC	2/24/00	12:06p	0.038	16,796	1.968	0.338	18,313	2.063	13,839
D0224034 SPC	2/24/00	12:10p	0.039	16,654	1.965	0.338	18,124	2.091	13,663
D0224035 SPC	2/24/00	12:15p	0.028	16,662	1.969	0.34	18,125	2.058	13,629
D0224036 SPC	2/24/00	12:19p	0.03	16,480	1.964	0.34	17,943	1.932	13,516
D0224037 SPC	2/24/00	12:24p	0.033	16,547	1.968	0.339	18,121	1.972	13,694
D0224038 SPC	2/24/00	12:28p	0.03	16,869	1.975	0.339	18,315	1.999	13,838
D0224039 SPC	2/24/00	12:33p	0.032	16,848	1.988	0.339	18,365	1.968	13,881
D0224040 SPC	2/24/00	12:37p	0.032	16,891	2.002	0.339	18,349	2.01	13,896
D0224041 SPC	2/24/00	12:42p	0.029	16,563	1.961	0.339	18,035	1.885	13,596
D0224042 SPC	2/24/00	12:47p	0.032	16,647	1.961	0.339	18,167	1.945	13,775
D0224043 SPC	2/24/00	12:51p	0.038	16,746	1.973	0.338	18,257	1.966	13,801
D0224044 SPC	2/24/00	12:56p	0.036	16,831	1.966	0.338	18,441	2.136	13,980
D0224045 SPC	2/24/00	1:00p	0.032	17,001	1.982	0.338	18,591	2.148	14,041
D0224046 SPC	2/24/00	1:05p	0.039	17,036	1.99	0.337	18,727	2.498	14,042
D0224047 SPC	2/24/00	1:09p	0.042	16,768	1.983	0.337	18,345	2.409	13,857
D0224048 SPC	2/24/00	1:14p	0.039	16,605	1.975	0.337	18,177	2.282	13,671
D0224049 SPC	2/24/00	1:18p	0.039	16,412	1.969	0.338	17,963	2.221	13,493
D0224050 SPC	2/24/00	1:23p	0.037	16,767	1.971	0.337	18,154	2.246	13,666
D0224051 SPC	2/24/00	1:27p	0.029	16,720	1.981	0.338	18,233	2.239	13,748
D0224052 SPC	2/24/00	1:32p	0.033	17,052	1.977	0.338	18,705	2.126	14,056
D0224053 SPC	2/24/00	1:36p	0.037	16,939	1.985	0.337	18,603	2.091	14,053
D0224054 SPC	2/24/00	1:41p	0.038	16,773	1.994	0.338	18,325	2.024	13,861
D0224055 SPC	2/24/00	1:45p	0.038	16,825	1.985	0.337	18,366	2.095	13,912
D0224056 SPC	2/24/00	1:50p	0.035	16,856	1.971	0.337	18,390	2.072	13,924
D0224057 SPC	2/24/00	1:54p	0.039	16,792	1.983	0.336	18,447	2.056	13,989
D0224058 SPC	2/24/00	1:59p	0.034	16,927	1.97	0.336	18,417	2.075	13,937
D0224059 SPC	2/24/00	2:03p	0.034	16,916	1.991	0.337	18,455	2.128	13,914
D0224060 SPC	2/24/00	2:08p	0.037	16,882	1.986	0.336	18,483	2.327	13,956
D0224061 SPC	2/24/00	2:13p	0.038	16,820	1.99	0.336	18,733	2.092	14,088

C-68

Table C-7. (Continued)

Data Collection Information			Quantification Method						
			Olin Mercury Plant		Olin 2			Olin 3	
File	Date	Time	sulfur hexafluoride	water	carbon monoxide	nitrous oxide	water	methane	Water
D0224062 SPC	2/24/00	2:17p	0.037	17,012	1.978	0.336	18,843	2.037	14,134
D0224063 SPC	2/24/00	2:22p	0.03	17,079	1.985	0.336	18,625	2.285	13,994
D0224064 SPC	2/24/00	2:26p	0.034	17,082	2.007	0.336	18,554	2.321	13,945
D0224065 SPC	2/24/00	2:31p	0.037	16,900	1.972	0.335	18,322	2.22	13,784
D0224066 SPC	2/24/00	2:35p	0.039	16,795	1.978	0.335	18,301	2.344	13,721
D0224067 SPC	2/24/00	2:40p	0.034	16,680	1.982	0.336	18,179	2.434	13,647
D0224068 SPC	2/24/00	2:44p	0.035	16,469	2.004	0.336	17,989	2.289	13,438
D0224069 SPC	2/24/00	2:49p	0.039	16,528	1.981	0.335	18,002	2.267	13,493
D0224070 SPC	2/24/00	2:53p	0.04	16,444	1.972	0.336	18,022	2.283	13,483
D0224071 SPC	2/24/00	2:58p	0.04	16,634	1.981	0.336	18,127	2.455	13,585
D0224072 SPC	2/24/00	3:02p	0.033	16,710	1.983	0.336	18,087	2.431	13,590
D0224073 SPC	2/24/00	3:07p	0.036	16,555	1.974	0.336	18,054	2.31	13,538
D0224074 SPC	2/24/00	3:11p	0.035	16,868	1.969	0.336	18,257	2.321	13,773
D0224075 SPC	2/24/00	3:16p	0.037	16,742	1.972	0.336	18,070	2.394	13,564
D0224076 SPC	2/24/00	3:20p	0.036	16,857	1.976	0.336	18,293	2.366	13,777
D0224077 SPC	2/24/00	3:25p	0.033	17,034	2.001	0.336	18,686	2.447	13,985
D0224078 SPC	2/24/00	3:29p	0.035	16,820	1.974	0.336	18,358	2.513	13,848
D0224079 SPC	2/24/00	3:34p	0.038	16,523	1.982	0.336	18,086	2.389	13,547
D0224080 SPC	2/24/00	3:39p	0.037	16,733	2.03	0.337	18,249	2.328	13,696
D0224081 SPC	2/24/00	3:43p	0.038	16,508	1.985	0.336	18,021	2.267	13,480
D0224082 SPC	2/24/00	3:48p	0.038	16,473	1.992	0.336	17,976	2.264	13,478
D0224083 SPC	2/24/00	3:52p	0.035	16,719	1.982	0.337	18,067	2.233	13,531
D0224084 SPC	2/24/00	3:57p	0.035	16,988	1.98	0.336	18,482	2.38	13,923
D0224085 SPC	2/24/00	4:01p	0.035	16,905	1.976	0.336	18,308	2.412	13,786
D0224086 SPC	2/24/00	4:06p	0.038	16,654	1.981	0.336	18,136	2.19	13,535
D0224087 SPC	2/24/00	4:10p	0.031	16,801	1.977	0.336	18,151	2.298	13,581
D0224088 SPC	2/24/00	4:15p	0.029	16,850	1.977	0.336	18,202	2.128	13,630
D0224089 SPC	2/24/00	4:19p	0.028	16,754	1.98	0.336	18,239	2.07	13,697
D0224090 SPC	2/24/00	4:24p	0.036	16,662	1.985	0.336	18,053	2.222	13,476
D0224091 SPC	2/24/00	4:28p	0.035	16,624	1.992	0.337	18,068	2.458	13,477

Table C-7. (Continued)

Data Collection Information			Quantification Method Concentrations in ppm						
File	Date	Time	Olin Mercury Plant		Olin 2		Olin 3		
			sulfur hexafluoride	water	carbon monoxide	nitrous oxide	water	methane	Water
D0224092 SPC	2/24/00	4:33p	0.037	16,719	1.976	0.337	18,119	2.535	13,553
D0224093 SPC	2/24/00	4:37p	0.036	16,740	1.982	0.336	18,153	2.623	13,632
D0224094 SPC	2/24/00	4:42p	0.038	17,026	1.981	0.336	18,312	2.922	13,745
D0224095 SPC	2/24/00	4:47p	0.038	16,736	1.979	0.337	18,225	3.116	13,683
D0224096 SPC	2/24/00	4:51p	0.038	16,882	1.981	0.336	18,329	3.296	13,773
D0224097 SPC	2/24/00	4:56p	0.04	16,785	1.98	0.336	18,242	2.971	13,720
D0224098 SPC	2/24/00	5:00p	0.04	16,748	1.986	0.336	18,185	2.57	13,646
D0224099 SPC	2/24/00	5:05p	0.037	16,931	1.984	0.337	18,276	2.656	13,736
D0224100 SPC	2/24/00	5:09p	0.037	16,830	1.984	0.337	18,285	2.785	13,764
D0224101 SPC	2/24/00	5:14p	0.039	16,774	1.98	0.337	18,214	2.699	13,687
D0224102 SPC	2/24/00	5:18p	0.039	16,813	1.98	0.337	18,192	2.627	13,703
D0224103 SPC	2/24/00	5:23p	0.04	16,687	1.986	0.337	18,117	2.683	13,584
D0224104 SPC	2/24/00	5:27p	0.037	16,665	1.987	0.337	18,148	2.749	13,629
D0224105 SPC	2/24/00	5:32p	0.038	16,770	1.987	0.337	18,149	2.864	13,635
D0224106 SPC	2/24/00	5:37p	0.038	16,679	1.989	0.337	18,265	3.22	13,719
D0224107 SPC	2/24/00	5:41p	0.037	16,996	1.991	0.337	18,496	3.945	13,873
D0224108 SPC	2/24/00	5:46p	0.036	17,141	1.992	0.336	18,806	4.26	13,915
D0224109 SPC	2/24/00	5:50p	0.036	17,163	1.997	0.337	18,732	4.028	13,949
D0224110 SPC	2/24/00	5:55p	0.036	17,108	1.993	0.337	18,706	3.761	13,968
D0224111 SPC	2/24/00	5:59p	0.038	17,035	1.99	0.337	18,691	3.67	13,962
D0224112 SPC	2/24/00	6:04p	0.039	17,090	1.989	0.337	18,672	3.59	13,967
D0224113 SPC	2/24/00	6:08p	0.038	17,143	1.991	0.337	18,840	3.689	14,023
D0224114 SPC	2/24/00	6:13p	0.035	17,243	1.995	0.337	18,862	3.704	14,050
D0224115 SPC	2/24/00	6:17p	0.04	17,338	2.001	0.338	18,970	3.766	14,037
D0224116 SPC	2/24/00	6:22p	0.036	17,245	1.999	0.338	19,084	3.809	14,113
D0224117 SPC	2/24/00	6:26p	0.038	17,400	2.004	0.338	19,276	4.061	14,202
D0224118 SPC	2/24/00	6:31p	0.037	17,563	2.02	0.339	19,342	4.386	14,222
D0224119 SPC	2/24/00	6:36p	0.035	17,648	2.023	0.339	19,346	4.824	14,248
D0224120 SPC	2/24/00	6:40p	0.036	17,661	2.02	0.34	19,371	4.874	14,280
D0224121 SPC	2/24/00	6:45p	0.037	17,635	2.023	0.339	19,325	4.388	14,260

C-70

Table C-7. (Continued)

Data Collection Information			Quantification Method						
			Olin Mercury Plant				Olin 2		Olin 3
File	Date	Time	sulfur hexafluoride	water	carbon monoxide	nitrous oxide	water	methane	Water
D0224122 SPC	2/24/00	6:49p	0.034	17,749	2.032	0.34	19,354	4.052	14,270
D0224123 SPC	2/24/00	6:54p	0.034	17,627	2.031	0.339	19,353	3.892	14,299
D0224124 SPC	2/24/00	6:58p	0.036	17,658	2.054	0.34	19,396	4.202	14,281
D0224125 SPC	2/24/00	7:03p	0.036	17,758	2.054	0.34	19,537	4.674	14,351
D0224126 SPC	2/24/00	7:07p	0.036	17,772	2.046	0.34	19,684	5.284	14,463
D0224127 SPC	2/24/00	7:12p	0.035	18,045	2.048	0.341	19,703	5.333	14,517
D0224128 SPC	2/24/00	7:16p	0.035	17,935	2.049	0.341	19,682	5.307	14,489
D0224129 SPC	2/24/00	7:21p	0.035	17,868	2.041	0.341	19,657	5.225	14,493
D0224130 SPC	2/24/00	7:25p	0.034	17,877	2.039	0.341	19,669	4.833	14,530
D0224131 SPC	2/24/00	7:30p	0.034	17,982	2.051	0.341	19,737	4.889	14,567
D0224132 SPC	2/24/00	7:35p	0.033	17,906	2.048	0.342	19,704	4.842	14,545
D0224133 SPC	2/24/00	7:39p	0.034	17,956	2.046	0.342	19,616	4.581	14,489
D0224134 SPC	2/24/00	7:44p	0.036	17,758	2.047	0.341	19,569	4.397	14,478
D0224135 SPC	2/24/00	7:48p	0.033	17,843	2.039	0.341	19,533	4.761	14,478
D0224136 SPC	2/24/00	7:53p	0.034	17,778	2.036	0.341	19,549	5.522	14,475
D0224137 SPC	2/24/00	7:57p	0.036	17,174	2.014	0.34	19,177	4.329	14,251
D0224138 SPC	2/24/00	8:02p	0.034	17,287	2.024	0.34	19,005	3.553	14,144
D0224139 SPC	2/24/00	8:06p	0.037	17,303	2.031	0.341	19,062	3.153	14,215
D0224140 SPC	2/24/00	8:11p	0.039	16,889	2.033	0.343	18,539	2.755	14,072
D0224141 SPC	2/24/00	8:15p	0.041	16,778	2.044	0.344	18,398	2.452	13,968
D0224142 SPC	2/24/00	8:20p	0.039	16,676	2.037	0.344	18,274	2.578	13,908
D0224143 SPC	2/24/00	8:24p	0.036	16,637	2.028	0.344	18,147	2.587	13,763
D0224144 SPC	2/24/00	8:29p	0.04	16,551	2.027	0.344	18,125	2.549	13,739
D0224145 SPC	2/24/00	8:33p	0.043	16,555	2.029	0.345	18,043	2.664	13,647
D0224146 SPC	2/24/00	8:38p	0.042	16,444	2.036	0.346	17,919	2.706	13,566
D0224147 SPC	2/24/00	8:43p	0.043	16,417	2.048	0.347	17,864	2.708	13,498
D0224148 SPC	2/24/00	8:47p	0.04	16,377	2.036	0.347	17,912	2.621	13,583
D0224149 SPC	2/24/00	8:52p	0.039	16,260	2.037	0.347	17,835	2.575	13,507
D0224150 SPC	2/24/00	8:56p	0.039	16,152	2.034	0.349	17,690	2.776	13,362
D0224151 SPC	2/24/00	9:01p	0.04	16,142	2.033	0.349	17,603	2.782	13,335

Table C-7. (Continued)

Data Collection Information			Quantification Method Concentrations in ppm						
File	Date	Time	Olin Mercury Plant		Olin 2		Olin 3		
			sulfur hexafluoride	water	carbon monoxide	nitrous oxide	water	methane	Water
D0224152 SPC	2/24/00	9:05p	0.042	15,929	2.028	0.349	17,524	2.731	13,226
D0224153 SPC	2/24/00	9:10p	0.043	15,819	2.028	0.349	17,372	2.607	13,075
D0224154 SPC	2/24/00	9:14p	0.04	15,755	2.048	0.35	17,235	2.671	12,995
D0224155 SPC	2/24/00	9:19p	0.041	15,694	2.038	0.35	17,184	2.673	12,950
D0224156 SPC	2/24/00	9:23p	0.042	15,678	2.034	0.348	17,131	2.653	12,895
D0224157 SPC	2/24/00	9:28p	0.041	15,857	2.042	0.35	17,179	2.457	12,924
D0224158 SPC	2/24/00	9:32p	0.04	15,583	2.043	0.349	17,086	2.37	12,839
D0224159 SPC	2/24/00	9:37p	0.039	15,484	2.046	0.35	17,010	2.281	12,783
D0224160 SPC	2/24/00	9:41p	0.037	15,480	2.054	0.348	16,977	2.374	12,744
D0224161 SPC	2/24/00	9:46p	0.04	15,360	2.069	0.348	16,910	2.495	12,673
D0224162 SPC	2/24/00	9:51p	0.042	15,493	2.076	0.349	16,974	2.484	12,684
D0224163 SPC	2/24/00	9:55p	0.041	15,224	2.103	0.35	16,768	2.502	12,519
D0224164 SPC	2/24/00	10:00p	0.04	15,199	2.134	0.35	16,757	2.519	12,481
D0224165 SPC	2/24/00	10:04p	0.04	15,067	2.082	0.349	16,811	2.485	12,594
D0224166 SPC	2/24/00	10:09p	0.041	14,864	2.065	0.349	16,832	2.444	12,626
D0224167 SPC	2/24/00	10:13p	0.043	15,255	2.066	0.35	16,857	2.427	12,653
D0224168 SPC	2/24/00	10:18p	0.044	15,219	2.053	0.349	16,803	2.326	12,607
D0224169 SPC	2/24/00	10:22p	0.044	15,076	2.065	0.349	16,780	2.298	12,605
D0224170 SPC	2/24/00	10:27p	0.042	15,211	2.084	0.349	16,777	2.197	12,587
D0224171 SPC	2/24/00	10:32p	0.041	15,348	2.114	0.35	16,772	2.077	12,581
D0224172 SPC	2/24/00	10:36p	0.043	15,169	2.054	0.351	16,668	2.082	12,509
D0224173 SPC	2/24/00	10:41p	0.044	14,929	2.061	0.35	16,328	2.236	12,303
D0224174 SPC	2/24/00	10:45p	0.041	14,820	2.045	0.352	16,085	2.261	12,208
D0224175 SPC	2/24/00	10:50p	0.042	15,067	2.046	0.35	16,517	2.099	12,391
D0224176 SPC	2/24/00	10:54p	0.041	15,063	2.056	0.349	16,528	2.058	12,377
D0224177 SPC	2/24/00	10:59p	0.044	14,954	2.062	0.349	16,478	2.087	12,358
D0224178 SPC	2/24/00	11:03p	0.041	14,992	2.057	0.349	16,425	2.159	12,332
D0224179 SPC	2/24/00	11:08p	0.041	14,904	2.052	0.35	16,286	2.174	12,255
D0224180 SPC	2/24/00	11:12p	0.041	14,855	2.122	0.352	16,123	2.048	12,150
D0224181 SPC	2/24/00	11:17p	0.044	14,908	2.059	0.35	16,190	1.965	12,210

Table C-7. (Continued)

Data Collection Information			Quantification Method Concentrations in ppm						
File	Date	Time	Olin Mercury Plant		Olin 2		Olin 3		
			sulfur hexafluoride	water	carbon monoxide	nitrous oxide	water	methane	Water
D0224182 SPC	2/24/00	11:22p	0.045	14,793	2.048	0.35	16,256	1.963	12,280
D0224183 SPC	2/24/00	11:26p	0.041	14,897	2.048	0.349	16,239	1.974	12,262
D0224184 SPC	2/24/00	11:31p	0.043	14,738	2.084	0.351	15,868	2.061	12,031
D0224185 SPC	2/24/00	11:35p	0.044	14,561	2.077	0.352	15,812	2.059	12,000
D0224186 SPC	2/24/00	11:40p	0.044	14,699	2.055	0.351	15,884	1.973	12,066
D0224187 SPC	2/24/00	11:44p	0.041	14,671	2.051	0.351	16,085	1.952	12,179
D0224188 SPC	2/24/00	11:49p	0.041	15,052	2.053	0.35	16,540	1.914	12,396
D0224189 SPC	2/24/00	11:53p	0.038	15,075	2.052	0.35	16,543	1.938	12,393
D0224190 SPC	2/24/00	11:58p	0.04	15,188	2.054	0.349	16,718	1.986	12,494
D0224191 SPC	2/25/00	12:02a	0.039	15,212	2.07	0.348	16,727	2.099	12,541
D0224192 SPC	2/25/00	12:07a	0.043	15,322	2.076	0.348	16,819	2.247	12,630
D0224193 SPC	2/25/00	12:12a	0.041	15,391	2.083	0.35	16,952	2.304	12,713
D0224194 SPC	2/25/00	12:16a	0.045	15,368	2.1	0.35	16,927	2.307	12,692
D0224195 SPC	2/25/00	12:21a	0.043	15,336	2.119	0.348	16,902	2.433	12,592
D0224196 SPC	2/25/00	12:25a	0.043	15,308	2.111	0.348	16,953	2.942	12,684
D0224197 SPC	2/25/00	12:30a	0.044	15,450	2.094	0.35	16,994	3.955	12,644
D0224198 SPC	2/25/00	12:34a	0.041	15,236	2.094	0.349	16,769	4.159	12,454
D0224199 SPC	2/25/00	12:39a	0.04	14,940	2.084	0.351	16,250	4.071	12,113
D0224200 SPC	2/25/00	12:43a	0.041	14,671	2.076	0.352	15,869	3.374	12,001
D0224201 SPC	2/25/00	12:48a	0.043	14,306	2.063	0.353	15,553	2.813	11,793
D0224202 SPC	2/25/00	12:53a	0.042	14,182	2.058	0.354	15,453	2.66	11,706
D0224203 SPC	2/25/00	12:57a	0.041	14,210	2.059	0.354	15,623	2.894	11,861
D0224204 SPC	2/25/00	1:02a	0.039	14,409	2.049	0.355	15,669	2.714	11,935
D0224205 SPC	2/25/00	1:06a	0.042	14,295	2.053	0.355	15,487	2.494	11,752
D0224206 SPC	2/25/00	1:11a	0.041	14,069	2.058	0.354	15,391	2.381	11,648
D0224207 SPC	2/25/00	1:15a	0.044	14,063	2.061	0.355	15,298	2.273	11,590
D0224208 SPC	2/25/00	1:20a	0.042	13,633	2.062	0.356	14,925	2.242	11,158
D0224209 SPC	2/25/00	1:25a	0.042	13,382	2.064	0.357	14,649	2.269	10,949
D0224210 SPC	2/25/00	1:29a	0.042	13,213	2.066	0.357	14,472	2.241	10,739
D0224211 SPC	2/25/00	1:34a	0.04	13,227	2.07	0.357	14,498	2.208	10,798

Table C-7. (Continued)

Data Collection Information			Quantification Method Concentrations in ppm						
File	Date	Time	Olin Mercury Plant		Olin 2		Olin 3		
			sulfur hexafluoride	water	carbon monoxide	nitrous oxide	water	methane	Water
D0224212 SPC	2/25/00	1:38a	0.042	13,334	2.061	0.357	14,583	2.132	10,861
D0224213 SPC	2/25/00	1:43a	0.043	13,429	2.06	0.356	14,643	2.121	10,906
D0224214 SPC	2/25/00	1:47a	0.042	13,404	2.062	0.356	14,644	2.118	10,934
D0224215 SPC	2/25/00	1:52a	0.043	13,330	2.087	0.357	14,523	2.093	10,818
D0224216 SPC	2/25/00	1:56a	0.042	13,253	2.067	0.357	14,474	2.135	10,794
D0224217 SPC	2/25/00	2:01a	0.041	13,367	2.068	0.357	14,565	2.159	10,871
D0224218 SPC	2/25/00	2:05a	0.042	13,215	2.066	0.357	14,405	2.187	10,733
D0224219 SPC	2/25/00	2:10a	0.044	13,106	2.064	0.357	14,260	2.158	10,591
D0224220 SPC	2/25/00	2:15a	0.042	13,088	2.095	0.358	14,187	2.121	10,497
D0224221 SPC	2/25/00	2:19a	0.04	12,785	2.12	0.358	13,858	2.189	10,272
D0224222 SPC	2/25/00	2:24a	0.042	12,681	2.089	0.358	13,998	2.229	10,346
D0224223 SPC	2/25/00	2:28a	0.04	12,802	2.087	0.357	13,810	2.345	10,264
D0224224 SPC	2/25/00	2:33a	0.039	12,942	2.122	0.357	14,180	2.56	10,445
D0224225 SPC	2/25/00	2:37a	0.042	13,357	2.132	0.357	14,565	2.609	10,773
D0224226 SPC	2/25/00	2:42a	0.046	13,095	2.156	0.358	14,222	2.834	10,435
D0224227 SPC	2/25/00	2:46a	0.044	12,971	2.133	0.357	14,141	2.716	10,344
D0224228 SPC	2/25/00	2:51a	0.043	13,130	2.141	0.357	14,295	2.501	10,521
D0224229 SPC	2/25/00	2:56a	0.044	13,248	2.137	0.357	14,428	2.694	10,687
D0224230 SPC	2/25/00	3:00a	0.043	13,082	2.121	0.357	14,333	2.498	10,592
D0224231 SPC	2/25/00	3:05a	0.038	13,057	2.102	0.358	14,282	2.512	10,591
D0224232 SPC	2/25/00	3:09a	0.04	13,177	2.116	0.358	14,370	2.842	10,657
D0224233 SPC	2/25/00	3:14a	0.046	12,987	2.121	0.358	14,349	3.222	10,583
D0224234 SPC	2/25/00	3:18a	0.042	13,493	2.136	0.356	14,754	4.074	10,896
D0224235 SPC	2/25/00	3:23a	0.042	13,626	2.142	0.356	14,922	4.844	11,025
D0224236 SPC	2/25/00	3:28a	0.043	13,038	2.161	0.358	14,241	4.142	10,375
D0224237 SPC	2/25/00	3:32a	0.042	13,073	2.164	0.358	14,349	3.483	10,457
D0224238 SPC	2/25/00	3:37a	0.043	13,180	2.158	0.357	14,433	3.386	10,520
D0224239 SPC	2/25/00	3:41a	0.043	13,253	2.161	0.357	14,454	3.197	10,576
D0224240 SPC	2/25/00	3:46a	0.044	13,129	2.136	0.358	14,369	3.122	10,510
D0224241 SPC	2/25/00	3:50a	0.044	13,103	2.126	0.358	14,408	3.156	10,497

Table C-7. (Continued)

Data Collection Information			Quantification Method Concentrations in ppm						
File	Date	Time	Olin Mercury Plant		Olin 2		Olin 3		
			sulfur hexafluoride	water	carbon monoxide	nitrous oxide	water	methane	Water
D0224242 SPC	2/25/00	3:55a	0.043	12,882	2.105	0.358	14,113	2.927	10,341
D0224243 SPC	2/25/00	3:59a	0.04	12,667	2.107	0.358	13,583	2.78	10,138
D0224244 SPC	2/25/00	4:04a	0.041	12,294	2.118	0.359	13,187	2.748	9,827
D0224245 SPC	2/25/00	4:09a	0.042	12,419	2.116	0.359	13,298	2.774	9,936
D0224246 SPC	2/25/00	4:13a	0.043	12,399	2.099	0.359	13,227	2.706	9,878
D0224247 SPC	2/25/00	4:18a	0.044	12,342	2.12	0.359	13,289	2.731	9,930
D0224248 SPC	2/25/00	4:22a	0.043	12,387	2.171	0.359	13,204	2.614	9,839
D0224249 SPC	2/25/00	4:27a	0.042	12,162	2.123	0.36	13,039	2.496	9,742
D0224250 SPC	2/25/00	4:31a	0.044	11,968	2.109	0.36	12,906	2.421	9,593
D0224251 SPC	2/25/00	4:36a	0.044	11,912	2.099	0.36	12,871	2.393	9,580
D0224252 SPC	2/25/00	4:41a	0.042	12,021	2.106	0.36	12,974	2.53	9,664
D0224253 SPC	2/25/00	4:45a	0.042	12,223	2.116	0.359	13,052	2.618	9,754
D0224254 SPC	2/25/00	4:50a	0.041	12,178	2.109	0.36	13,096	2.31	9,789
D0224255 SPC	2/25/00	4:54a	0.045	12,246	2.1	0.361	13,160	2.09	9,876
D0224256 SPC	2/25/00	4:59a	0.043	12,229	2.153	0.362	13,061	2.157	9,755
D0224257 SPC	2/25/00	5:03a	0.043	11,977	2.173	0.362	12,873	2.198	9,551
D0224258 SPC	2/25/00	5:08a	0.043	11,817	2.172	0.362	12,755	2.244	9,429
D0224259 SPC	2/25/00	5:13a	0.039	11,784	2.175	0.363	12,657	2.26	9,316
D0224260 SPC	2/25/00	5:17a	0.043	11,553	2.152	0.363	12,452	2.292	9,154
D0224261 SPC	2/25/00	5:22a	0.042	11,639	2.172	0.362	12,579	2.293	9,246
D0224262 SPC	2/25/00	5:26a	0.045	11,899	2.15	0.361	12,801	2.288	9,495
D0224263 SPC	2/25/00	5:31a	0.045	11,959	2.168	0.361	12,914	2.391	9,568
D0224264 SPC	2/25/00	5:35a	0.043	12,038	2.148	0.361	12,935	2.411	9,582
D0224265 SPC	2/25/00	5:40a	0.046	11,871	2.137	0.361	12,830	2.323	9,513
D0224266 SPC	2/25/00	5:45a	0.042	11,809	2.138	0.361	12,759	2.379	9,476
D0224267 SPC	2/25/00	5:49a	0.042	11,673	2.138	0.362	12,546	2.367	9,267
D0224268 SPC	2/25/00	5:54a	0.043	11,586	2.208	0.363	12,467	2.342	9,152
D0224269 SPC	2/25/00	5:58a	0.042	11,563	2.202	0.363	12,380	2.311	9,074
D0224270 SPC	2/25/00	6:03a	0.043	11,592	2.189	0.363	12,429	2.288	9,150
D0224271 SPC	2/25/00	6:07a	0.041	11,629	2.219	0.363	12,497	2.282	9,179

C-75

C-75

Table C-7. (Continued)

Data Collection Information			Quantification Method Concentrations in ppm						
File	Date	Time	Olin Mercury Plant		Olin 2		Olin 3		
			sulfur hexafluoride	water	carbon monoxide	nitrous oxide	water	methane	Water
D0224272 SPC	2/25/00	6:12a	0.041	11,632	2.255	0.363	12,596	2.249	9,267
D0224273 SPC	2/25/00	6:16a	0.041	11,889	2.619	0.365	12,861	2.412	9,386
D0224274 SPC	2/25/00	6:21a	0.042	12,113	2.473	0.365	13,019	2.943	9,558
D0224275 SPC	2/25/00	6:26a	0.044	11,887	2.304	0.364	12,828	2.836	9,444
D0224276 SPC	2/25/00	6:30a	0.043	11,873	2.253	0.364	12,794	2.783	9,451
D0224277 SPC	2/25/00	6:35a	0.042	11,846	2.268	0.363	12,777	2.736	9,386
D0224278 SPC	2/25/00	6:39a	0.043	11,713	2.407	0.365	12,751	2.657	9,318
D0224279 SPC	2/25/00	6:44a	0.042	11,838	2.457	0.365	12,798	2.575	9,361
D0224280 SPC	2/25/00	6:48a	0.04	12,011	2.46	0.365	12,853	2.515	9,444
D0224281 SPC	2/25/00	6:53a	0.041	11,894	2.515	0.365	12,867	2.531	9,410
D0224282 SPC	2/25/00	6:58a	0.039	11,833	2.479	0.365	12,821	2.54	9,381
D0224283 SPC	2/25/00	7:02a	0.037	11,665	2.441	0.365	12,640	2.516	9,228
D0224284 SPC	2/25/00	7:07a	0.042	11,511	2.406	0.365	12,504	2.522	9,142
D0224285 SPC	2/25/00	7:11a	0.042	11,447	2.706	0.368	12,525	2.539	9,037
D0224286 SPC	2/25/00	7:16a	0.039	11,597	2.653	0.368	12,587	2.559	9,070
D0224287 SPC	2/25/00	7:20a	0.04	11,457	2.726	0.369	12,497	2.577	8,921
D0224288 SPC	2/25/00	7:25a	0.042	11,696	2.746	0.368	12,748	2.62	9,190
D0224289 SPC	2/25/00	7:29a	0.042	11,756	2.709	0.368	12,786	2.749	9,200
D0224290 SPC	2/25/00	7:34a	0.054	11,023	2.691	0.367	12,889	2.759	9,322
D0224291 SPC	2/25/00	7:39a	0.059	10,623	2.744	0.369	12,699	2.795	9,046
D0224292 SPC	2/25/00	7:43a	0.013	11,605	2.812	0.369	12,692	2.872	8,907
D0224293 SPC	2/25/00	7:48a	0.006	11,629	2.886	0.37	12,735	2.999	8,881
D0224294 SPC	2/25/00	7:52a	0.003	11,797	2.77	0.368	12,906	3.053	9,226
D0224295 SPC	2/25/00	7:57a	0.002	12,090	2.591	0.366	13,153	2.841	9,564
D0224296 SPC	2/25/00	8:01a	0.001	12,221	2.62	0.366	13,280	2.79	9,685
D0224297 SPC	2/25/00	8:06a	0	12,257	2.551	0.365	13,291	2.809	9,709
D0224298 SPC	2/25/00	8:11a	0	12,322	2.499	0.364	13,331	2.776	9,808
D0224299 SPC	2/25/00	8:15a	0	12,475	2.462	0.364	13,445	2.775	9,926
D0224300 SPC	2/25/00	8:20a	0	12,707	2.566	0.365	14,021	2.926	10,171
D0224301 SPC	2/25/00	8:24a	0	12,872	2.564	0.364	14,273	2.917	10,323

Table C-7. (Continued)

Data Collection Information			Quantification Method						
			Olin Mercury Plant		Olin 2			Olin 3	
File	Date	Time	sulfur hexafluoride	water	carbon monoxide	nitrous oxide	water	methane	Water
D0224302 SPC	2/25/00	8:29a	0	13,065	2.491	0.363	14,447	2.838	10,543
D0224303 SPC	2/25/00	8:33a	0	13,233	2.468	0.369	14,661	2.841	10,766
D0224304 SPC	2/25/00	8:38a	0	13,306	2.485	0.374	14,762	2.966	10,874
D0224305 SPC	2/25/00	8:43a	0	13,420	2.489	0.375	14,835	3.054	10,877
D0224306 SPC	2/25/00	8:47a	0	13,500	2.502	0.377	14,912	3.136	10943

Appendix D
Roof Vent Manual Velocity Data

(Intentionally Blank)

Table D-1. East Platform: Hand-Held Anemometer Data At LOA Beam Height

Date	Sampling Location	Points												Average			
		-3	-2	-1	1	2	3	4	5	6	7	8	9		10	11	12
2/22	Meters Fm. S. Wall		-0.41	-0.2	0.41	0.81	1.2	1.6	2.0	2.4	2.84	3.25	3.66	4.06	4.57	4.88	
	Inches Fm. S. Wall		-16	-8	16	32	48	64	80	96	112	128	144	160	180	192	
	1545 hrs (Prop)		0	0.6	1	1.1	1.1	1.5	1.5	0.4	1.1	1.1	1.2	1.8	0.6	0	0.9
2/23	Meters Fm. S. Wall	-0.51	-0.1	0	0.41	0.81	1.2	1.6	2.0	2.4	2.84	3.25	3.66	4.06	4.52	4.57	
	Inches Fm. S. Wall	-20	-4	0	16	32	48	64	80	96	112	128	144	160	178	180	
	~ 1008 hrs (Prop)	0	0.6	1.2	1.4	1.6	1.6	1.4	1.7	0.1	0.6	0.9	1.2	1.4	0.6	0	1
	~ 1021 hrs (Hot Wire)			1.5	2	2	1.7	1.6	1.4	0.8	1.2	1.5	1.4	1.9	1.2		1.5

D-1

Table D-2. West Platform: Hand-Held Anemometer Data At LOA Beam Height

Date	Sampling Location	Points														Average		
		+3	+2	+1	10	9	8	7	6	5	4	3	2	1	-1		-2	-3
2/22	Meters Fm. S. Wall	0.05	0.2	0.2	0.61	1.0	1.4	1.8	2.2	2.64	3.05	3.45	3.86	4.27	4.67	4.78	5.08	
	Inches Fm. S. Wall	2	6	8	24	40	56	72	88	104	120	136	152	168	184	188	200	
	1500 hrs (Prop)	0	0.6	1.1	1.7	1.4	0.9	1	0.8	0.8	0.8	1.2	1.5	1.4	1	0.6	0	0.9
2/23	1030 hrs (Prop)	0	0.6	1.6	1.7	1.2	1.1	0.8	0.3	0.5	0.9	1	1.5	1.7	1.2	0.6	0	0.9

Appendix E

Manual Velocity Data for Cell Building Openings and Associated Flow Balance Calculations

(Intentionally Blank)

Table E-1. Hand-Held Velocity Measurements in Cell Building Openings on 2/24/00^a

Velocity Sampling Point	Approximate "X" Coordinate (ft from NE corner) ^b	Approximate "Y" Coordinate (ft above curb)	Available Open Area (ft ²)	"Prop" Air Velocity (m/s)	"Prop" Air Velocity (fpm)	"Prop" Vol. Flowrate (acfm)	Std. Flowrate (wscf/min)	"Hot" Wire" Air Velocity (fpm)	"Hot" Wire" Vol. Flowrate (acfm)	Std. Flowrate (wscf/min)
1a	8.25	9.87	109	1.1	2.2E+02	2.4E+04	2.6E+04	310	3.38E+04	3.63E+04
1b	8.25	3.29	109	0.65	1.3E+02	1.4E+04	1.5E+04	245	2.67E+04	2.87E+04
2a	24.75	9.87	109	1.1	2.2E+02	2.4E+04	2.6E+04	410	4.47E+04	4.81E+04
2b (C Filter)	29.84	3.29	50.6	0.7	1.4E+02	7.1E+03	7.6E+03	385	1.95E+04	2.10E+04
3a	41.25	9.87	109	1.3	2.6E+02	2.8E+04	3.0E+04	395	4.31E+04	4.63E+04
3b	41.25	3.29	109	1.1	2.2E+02	2.4E+04	2.6E+04	290	3.16E+04	3.40E+04
4a	57.75	9.87	109	1.1	2.2E+02	2.4E+04	2.6E+04	270	2.94E+04	3.16E+04
4b	57.75	3.29	109	0.9	1.8E+02	2.0E+04	2.1E+04	290	3.16E+04	3.40E+04
5a	74.25	9.87	109	1	2.0E+02	2.2E+04	2.4E+04	240	2.62E+04	2.82E+04
5b	74.25	3.29	109	0.7	1.4E+02	1.5E+04	1.6E+04	260	2.83E+04	3.04E+04
6a	90.75	9.87	109	0.7	1.4E+02	1.5E+04	1.6E+04	245	2.67E+04	2.87E+04
6b	90.75	3.29	109	0.2	3.9E+01	4.3E+03	4.6E+03	215	2.34E+04	2.52E+04
7a	8.25	9.87	109	1	2.0E+02	2.2E+04	2.4E+04	240	2.62E+04	2.81E+04
7b	8.25	3.29	109	0.8	1.6E+02	1.7E+04	1.8E+04	190	2.07E+04	2.22E+04
8a	24.75	9.87	109	0.8	1.6E+02	1.7E+04	1.8E+04	245	2.67E+04	2.87E+04
8b	24.75	3.29	109	0.3	5.9E+01	6.4E+03	6.9E+03	195	2.13E+04	2.29E+04
9a	41.25	9.87	109	0.8	1.6E+02	1.7E+04	1.8E+04	220	2.40E+04	2.58E+04
9b	41.25	3.29	109	0.1	2.0E+01	2.2E+03	2.4E+03	50	5.45E+03	5.85E+03
10a	57.75	9.87	109	0.8	1.6E+02	1.7E+04	1.8E+04	245	2.67E+04	2.87E+04
10b	57.75	3.29	109	0.5	9.8E+01	1.1E+04	1.2E+04	197	2.15E+04	2.31E+04
11a	74.25	9.87	109	0.5	9.8E+01	1.1E+04	1.2E+04	215	2.34E+04	2.51E+04
11b	74.25	3.29	109	0.2	3.9E+01	4.3E+03	4.6E+03	113	1.23E+04	1.32E+04
12a	90.75	9.87	109	0.8	1.6E+02	1.7E+04	1.8E+04	205	2.23E+04	2.39E+04
12b	90.75	3.29	109	0.3	5.9E+01	6.4E+03	6.9E+03	150	1.64E+04	1.76E+04
13a	8.25	9.87	109	0	0.0E+00	0.0E+00	0.0E+00	16	1.74E+03	1.87E+03
13b	8.25	3.29	109	0	0.0E+00	0.0E+00	0.0E+00	11	1.20E+03	1.29E+03
14 (Small Door)	N/A	N/A	100	0	0.0E+00	0.0E+00	0.0E+00	108	1.08E+04	1.16E+04
15 (Large Door)	N/A	N/A	252	0	0.0E+00	0.0E+00	0.0E+00	65	1.64E+04	1.76E+04
16a	87.92	2.39	17.2	0.9	1.8E+02	3.1E+03	3.3E+03	153	2.63E+03	2.83E+03
16b	87.92	0.8	17.2	0.9	1.8E+02	3.1E+03	3.3E+03	131	2.25E+03	2.42E+03
17a	72.09	2.39	19.4	0.7	1.4E+02	2.7E+03	2.9E+03	225	4.37E+03	4.70E+03
17b	72.09	0.8	19.4	0.8	1.6E+02	3.1E+03	3.3E+03	177	3.43E+03	3.69E+03
18a	41.25	2.39	26.2	1	2.0E+02	5.2E+03	5.6E+03	265	6.94E+03	7.46E+03

E-1

Table E-1. (Continued)

Velocity Sampling Point	Approximate "X" Coordinate (ft from NE corner) ^b	Approximate "Y" Coordinate (ft above curb)	Available Open Area (ft ²)	"Prop" Air Velocity (m/s)	"Prop" Air Velocity (fpm)	"Prop" Vol. Flowrate (acfm)	Std. Flowrate (wscf/min)	"Hot Wire" Air Velocity (fpm)	"Hot Wire" Vol. Flowrate (acfm)	Std. Flowrate (wscf/min)
18b	41.25	0.8	26.2	1	2.0E+02	5.2E+03	5.6E+03	83	2.17E+03	2.33E+03
20a	24.75	5	9.17	0.3	5.9E+01	5.4E+02	5.8E+02	88	8.07E+02	8.67E+02
20b	24.75	1.67	9.17	0.8	1.6E+02	1.5E+03	1.6E+03	200	1.83E+03	1.97E+03
21a	12.29	2.39	13.4	0.3	5.9E+01	7.9E+02	8.5E+02	53	7.10E+02	7.63E+02
21b	12.29	0.8	13.4	0.3	5.9E+01	7.9E+02	8.5E+02	100	1.34E+03	1.44E+03
22a	11.09	2.39	17.2	0.7	1.4E+02	2.4E+03	2.6E+03	184	3.16E+03	3.40E+03
22b	11.09	0.8	17.2	0.7	1.4E+02	2.4E+03	2.6E+03	130	2.24E+03	2.41E+03
23a	19.34	2.39	9.02	0.3	5.9E+01	5.3E+02	5.7E+02	130	1.17E+03	1.26E+03
23b	19.34	0.8	9.02	0.6	1.2E+02	1.1E+03	1.2E+03	100	9.02E+02	9.70E+02
24a	41.25	2.39	26.2	0	0.0E+00	0.0E+00	0.0E+00	20	5.24E+02	5.63E+02
24b	41.25	0.8	26.2	0.3	5.9E+01	1.5E+03	1.6E+03	87	2.28E+03	2.45E+03
25a	64.46	5	10.3	-0.3	-5.9E+01	-6.1E+02	-6.6E+02	140	1.44E+03	1.55E+03
25b	64.46	1.67	10.3	0	0.0E+00	0.0E+00	0.0E+00	50	5.15E+02	5.54E+02
26a	100.5	5	10.0	0.3	5.9E+01	5.9E+02	6.3E+02	126	1.26E+03	1.35E+03
26b	100.5	1.67	10.0	0.3	5.9E+01	5.9E+02	6.3E+02	62	6.20E+02	6.66E+02
27a	123.8	2.39	26.2	0.3	5.9E+01	1.5E+03	1.6E+03	137	3.59E+03	3.86E+03
27b	123.8	0.8	26.2	0.5	9.8E+01	2.6E+03	2.8E+03	156	4.09E+03	4.40E+03
28a	140.3	2.39	26.2	0.5	9.8E+01	2.6E+03	2.8E+03	90	2.36E+03	2.54E+03
28b	140.3	0.8	26.2	0.5	9.8E+01	2.6E+03	2.8E+03	158	4.14E+03	4.45E+03
29a	156.8	5	9.44	0.4	7.9E+01	7.5E+02	8.1E+02	45	4.25E+02	4.57E+02
29b	156.8	1.67	9.44	0.6	1.2E+02	1.1E+03	1.2E+03	120	1.13E+03	1.21E+03
	No. of Fans ^c	11				2.43E+05	2.61E+05		2.43E+05	2.61E+05
	Totals		3567.46			6.6E+05	7.1E+05		9.41E+05	1.01E+06
						Volume of moist air mix @ inlet (v ₁ = actual ft ³ /lb _m)	12.735			

^a fpm = ft/min; acfm = actual ft³/min; and wscf/min = wet standard ft³/min.

^b Points 22-29 from SE corner.

^c Assumes fan ratings = 22,100 acfm each.

E-2

E-2

Table E-2. (Continued)

Table E-2. Hand-Held Velocity Measurements in Cell Building Openings on 2/25/00^a

Velocity Sampling Point	Approximate "X" Coordinate (ft from NE corner) ^b	Approximate "Y" Coordinate (ft above curb)	Available Open Area (ft ²)	"Prop" Air Velocity (m/s)	"Prop" Air Velocity (fpm)	"Prop" Vol. Flowrate (acfm)	Std. Flowrate (wscf/min)
1a	8.25	9.87	109	0.9	1.8E+02	2.0E+04	2.1E+04
1b	8.25	3.29	109	0.4	7.9E+01	8.6E+03	9.2E+03
2a	24.75	9.87	109	0.8	1.6E+02	1.7E+04	1.8E+04
2b (C Filter)	29.84	3.29	50.6	0	0.0E+00	0.0E+00	0.0E+00
3a	41.25	9.87	109	1	2.0E+02	2.2E+04	2.3E+04
3b	41.25	3.29	109	0.4	7.9E+01	8.6E+03	9.2E+03
4a	57.75	9.87	109	1	2.0E+02	2.2E+04	2.3E+04
4b	57.75	3.29	109	0.5	9.8E+01	1.1E+04	1.2E+04
5a	74.25	9.87	109	0.8	1.6E+02	1.7E+04	1.8E+04
5b	74.25	3.29	109	0.4	7.9E+01	8.6E+03	9.2E+03
6a	90.75	9.87	109	0.3	5.9E+01	6.4E+03	6.8E+03
6b	90.75	3.29	109	0	0.0E+00	0.0E+00	0.0E+00
7a	8.25	9.87	109	0.7	1.4E+02	1.5E+04	1.6E+04
7b	8.25	3.29	109	0.4	7.9E+01	8.6E+03	9.2E+03
8a	24.75	9.87	109	0.6	1.2E+02	1.3E+04	1.4E+04
8b	24.75	3.29	109	0	0.0E+00	0.0E+00	0.0E+00
9a	41.25	9.87	109	0.5	9.8E+01	1.1E+04	1.2E+04
9b	41.25	3.29	109	0	0.0E+00	0.0E+00	0.0E+00
10a	57.75	9.87	109	0.2	3.9E+01	4.3E+03	4.6E+03
10b	57.75	3.29	109	0	0.0E+00	0.0E+00	0.0E+00
11a	74.25	9.87	109	0.1	2.0E+01	2.2E+03	2.3E+03
11b	74.25	3.29	109	0	0.0E+00	0.0E+00	0.0E+00
12a	90.75	9.87	109	0.6	1.2E+02	1.3E+04	1.4E+04
12b	90.75	3.29	109	0.4	7.9E+01	8.6E+03	9.2E+03
13a	8.25	9.87	109	0	0.0E+00	0.0E+00	0.0E+00
13b	8.25	3.29	109	0	0.0E+00	0.0E+00	0.0E+00
14 (Small Door)	N/A	N/A	100	0.1	2.0E+01	2.0E+03	2.1E+03
15 (Large Door)	N/A	N/A	252	0	0.0E+00	0.0E+00	0.0E+00
16a	87.92	2.39	17.2	0.7	1.4E+02	2.4E+03	2.6E+03
16b	87.92	0.8	17.2	0.7	1.4E+02	2.4E+03	2.6E+03
17a	72.09	2.39	19.4	0.7	1.4E+02	2.7E+03	2.9E+03
17b	72.09	0.8	19.4	0.8	1.6E+02	3.1E+03	3.3E+03
18a	41.25	2.39	26.2	1.1	2.2E+02	5.8E+03	6.2E+03

Table E-2. (Continued)

Velocity Sampling Point	Approximate "X" Coordinate (ft from NE corner) ^b	Approximate "Y" Coordinate (ft above curb)	Available Open Area (ft ²)	"Prop" Air Velocity (m/s)	"Prop" Air Velocity (fpm)	"Prop" Vol. Flowrate (acfm)	Std. Flowrate (wscf/min)
18b	41.25	0.8	26.2	1	2.0E+02	5.2E+03	5.5E+03
20a	24.75	5	9.17	0	0.0E+00	0.0E+00	0.0E+00
20b	24.75	1.67	9.17	0	0.0E+00	0.0E+00	0.0E+00
21a	12.29	2.39	13.4	0	0.0E+00	0.0E+00	0.0E+00
21b	12.29	0.8	13.4	0.9	1.8E+02	2.4E+03	2.6E+03
22a	11.09	2.39	17.2	0.5	9.8E+01	1.7E+03	1.8E+03
22b	11.09	0.8	17.2	0.5	9.8E+01	1.7E+03	1.8E+03
23a	19.34	2.39	9.02	0.5	9.8E+01	8.8E+02	9.4E+02
23b	19.34	0.8	9.02	0.7	1.4E+02	1.3E+03	1.4E+03
24a	41.25	2.39	26.2	0	0.0E+00	0.0E+00	0.0E+00
24b	41.25	0.8	26.2	0.1	2.0E+01	5.2E+02	5.5E+02
25a	64.46	5	10.3	-1	-2.0E+02	-2.1E+03	-2.2E+03
25b	64.46	1.67	10.3	0	0.0E+00	0.0E+00	0.0E+00
26a	100.5	5	10.0	0.3	5.9E+01	5.9E+02	6.3E+02
26b	100.5	1.67	10.0	0.7	1.4E+02	1.4E+03	1.5E+03
27a	123.8	2.39	26.2	0.8	1.6E+02	4.2E+03	4.5E+03
27b	123.8	0.8	26.2	0.6	1.2E+02	3.1E+03	3.3E+03
28a	140.3	2.39	26.2	0.7	1.4E+02	3.7E+03	3.9E+03
28b	140.3	0.8	26.2	0.8	1.6E+02	4.2E+03	4.5E+03
29a	156.8	5	9.44	0	0.0E+00	0.0E+00	0.0E+00
29b	156.8	1.67	9.44	0.5	9.8E+01	9.3E+02	9.9E+02
	No. of Fans ^c	13				2.87E+05	3.06E+05
			Totals	3567.46		5.5E+05	5.9E+05
					Volume of moist air mix @ inlet (v ₁ = actual ft ³ /lb _m)	12.855	

^a fpm = ft/min; acfm = actual ft³/min; and wscf/min = wet standard ft³/min.

^b Points 22-29 from SE corner.

^c Assumes fan ratings = 22,100 acfm each.

E-4

Table E-3. Roof Vent Optical Anemometer Results on 2/24/00^a

LOA Time	LOA Reading (actual m/s)	Vol. Air Flow (acfm)	DB Air Temp. (° C)	DB Air Temp. (° F)	Std. Flowrate (wscf/min)	Rel. Humidity (%)
5:30:10	1.10	6.14E+05	23.4	74.1	6.28E+05	49.1
5:31:10	1.06	5.91E+05	23.4	74.1	6.04E+05	49.1
5:32:10	1.03	5.75E+05	23.4	74.1	5.88E+05	49.1
5:34:10	1.02	5.69E+05	23.4	74.1	5.82E+05	49.1
5:35:10	1.13	6.30E+05	23.4	74.1	6.44E+05	49.1
5:36:10	1.03	5.75E+05	23.4	74.1	5.88E+05	49.1
5:37:10	1.08	6.02E+05	23.4	74.1	6.15E+05	49.1
5:38:15	1.00	5.58E+05	23.4	74.1	5.70E+05	49.1
5:39:10	1.08	6.02E+05	23.4	74.1	6.15E+05	49.1
5:40:10	1.02	5.69E+05	23.4	74.1	5.82E+05	49.1
5:41:10	1.06	5.91E+05	23.4	74.1	6.04E+05	49.1
5:42:10	1.01	5.63E+05	23.4	74.1	5.76E+05	49.1
5:43:10	0.95	5.30E+05	23.4	74.1	5.42E+05	49.1
5:44:10	0.96	5.36E+05	23.4	74.1	5.48E+05	49.1
5:45:10	0.91	5.08E+05	23.5	74.3	5.19E+05	49.3
5:46:10	0.93	5.19E+05	23.5	74.3	5.30E+05	49.3
5:47:10	0.95	5.30E+05	23.5	74.3	5.42E+05	49.3
5:48:10	1.02	5.69E+05	23.5	74.3	5.81E+05	49.3
5:49:10	0.95	5.30E+05	23.5	74.3	5.42E+05	49.3
5:51:15	1.02	5.69E+05	23.5	74.3	5.81E+05	49.3
5:52:10	1.02	5.69E+05	23.5	74.3	5.81E+05	49.3
5:53:10	0.95	5.30E+05	23.5	74.3	5.42E+05	49.3
5:54:10	1.01	5.63E+05	23.5	74.3	5.75E+05	49.3
5:55:10	0.96	5.36E+05	23.5	74.3	5.48E+05	49.3
5:56:10	1.00	5.58E+05	23.5	74.3	5.70E+05	49.3
5:57:10	1.01	5.63E+05	23.5	74.3	5.75E+05	49.3
5:58:10	0.98	5.47E+05	23.5	74.3	5.59E+05	49.3
5:59:10	0.91	5.08E+05	23.5	74.3	5.19E+05	49.3
6:00:10	0.96	5.36E+05	23.6	74.5	5.48E+05	49.4
6:01:10	1.03	5.75E+05	23.6	74.5	5.87E+05	49.4
6:02:15	0.91	5.08E+05	23.6	74.5	5.19E+05	49.4
6:03:10	0.89	4.96E+05	23.6	74.5	5.07E+05	49.4
6:04:10	0.95	5.30E+05	23.6	74.5	5.41E+05	49.4
6:05:10	0.95	5.30E+05	23.6	74.5	5.41E+05	49.4
6:06:10	0.98	5.47E+05	23.6	74.5	5.59E+05	49.4
6:07:10	0.98	5.47E+05	23.6	74.5	5.59E+05	49.4
6:08:10	1.06	5.91E+05	23.6	74.5	6.04E+05	49.4

Table E-3. (Continued)

LOA Time	LOA Reading (actual m/s)	Vol. Air Flow (acfm)	DB Air Temp. (° C)	DB Air Temp. (° F)	Std. Flowrate (wscf/min)	Rel. Humidity (%)
6:09:10	0.99	5.52E+05	23.6	74.5	5.64E+05	49.4
6:10:10	1.05	5.86E+05	23.6	74.5	5.99E+05	49.4
6:11:10	1.05	5.86E+05	23.6	74.5	5.99E+05	49.4
6:12:10	0.98	5.47E+05	23.6	74.5	5.59E+05	49.4
6:13:10	0.97	5.41E+05	23.6	74.5	5.53E+05	49.4
6:15:10	0.94	5.24E+05	23.5	74.3	5.35E+05	49.1
6:16:10	1.04	5.80E+05	23.5	74.3	5.93E+05	49.1
6:17:10	1.05	5.86E+05	23.5	74.3	5.99E+05	49.1
6:18:10	1.14	6.36E+05	23.5	74.3	6.50E+05	49.1
6:19:10	1.09	6.08E+05	23.5	74.3	6.21E+05	49.1
6:20:10	1.12	6.25E+05	23.5	74.3	6.39E+05	49.1
6:21:10	1.07	5.97E+05	23.5	74.3	6.10E+05	49.1
6:22:10	1.06	5.91E+05	23.5	74.3	6.04E+05	49.1
6:23:10	1.15	6.42E+05	23.5	74.3	6.56E+05	49.1
6:24:10	1.12	6.25E+05	23.5	74.3	6.39E+05	49.1
6:26:10	1.15	6.42E+05	23.5	74.3	6.56E+05	49.1
6:27:10	1.14	6.36E+05	23.5	74.3	6.50E+05	49.1
6:28:10	1.06	5.91E+05	23.5	74.3	6.04E+05	49.1
6:29:10	1.02	5.69E+05	23.5	74.3	5.81E+05	49.1
6:30:10	1.03	5.75E+05	23.6	74.5	5.87E+05	48.6
6:31:10	1.10	6.14E+05	23.6	74.5	6.27E+05	48.6
6:32:10	1.02	5.69E+05	23.6	74.5	5.81E+05	48.6
6:33:10	0.94	5.24E+05	23.6	74.5	5.35E+05	48.6
6:34:10	0.98	5.47E+05	23.6	74.5	5.59E+05	48.6
6:35:10	1.03	5.75E+05	23.6	74.5	5.87E+05	48.6
6:36:10	1.07	5.97E+05	23.6	74.5	6.10E+05	48.6
6:37:10	1.04	5.80E+05	23.6	74.5	5.92E+05	48.6
6:38:10	1.01	5.63E+05	23.6	74.5	5.75E+05	48.6
6:39:10	0.96	5.36E+05	23.6	74.5	5.48E+05	48.6
6:43:10	0.99	5.52E+05	23.6	74.5	5.64E+05	48.6
6:44:10	0.95	5.30E+05	23.6	74.5	5.41E+05	48.6
6:45:10	0.92	5.13E+05	23.7	74.7	5.24E+05	48.1
6:46:10	0.95	5.30E+05	23.7	74.7	5.41E+05	48.1
6:47:10	1.05	5.86E+05	23.7	74.7	5.98E+05	48.1
6:49:10	0.97	5.41E+05	23.7	74.7	5.52E+05	48.1
6:50:10	1.00	5.58E+05	23.7	74.7	5.70E+05	48.1
6:51:10	0.99	5.52E+05	23.7	74.7	5.64E+05	48.1

Table E-3. (Continued)

LOA Time	LOA Reading (actual m/s)	Vol. Air Flow (acfm)	DB Air Temp. (° C)	DB Air Temp. (° F)	Std. Flowrate (wscf/min)	Rel. Humidity (%)
6:52:10	0.97	5.41E+05	23.7	74.7	5.52E+05	48.1
6:53:10	1.04	5.80E+05	23.7	74.7	5.92E+05	48.1
6:54:10	1.04	5.80E+05	23.7	74.7	5.92E+05	48.1
6:55:10	1.02	5.69E+05	23.7	74.7	5.81E+05	48.1
6:56:10	1.04	5.80E+05	23.7	74.7	5.92E+05	48.1
6:57:10	1.13	6.30E+05	23.7	74.7	6.43E+05	48.1
6:58:10	1.06	5.91E+05	23.7	74.7	6.03E+05	48.1
6:59:10	0.98	5.47E+05	23.7	74.7	5.59E+05	48.1
7:00:10	0.98	5.47E+05	23.5	74.3	5.59E+05	48.1
7:01:10	0.97	5.41E+05	23.5	74.3	5.53E+05	48.1
7:02:10	1.03	5.75E+05	23.5	74.3	5.88E+05	48.1
7:03:10	0.97	5.41E+05	23.5	74.3	5.53E+05	48.1
7:05:10	1.08	6.02E+05	23.5	74.3	6.15E+05	48.1
7:06:10	1.09	6.08E+05	23.5	74.3	6.21E+05	48.1
7:07:10	0.97	5.41E+05	23.5	74.3	5.53E+05	48.1
7:08:10	1.06	5.91E+05	23.5	74.3	6.04E+05	48.1
7:09:10	1.16	6.47E+05	23.5	74.3	6.61E+05	48.1
7:10:10	1.08	6.02E+05	23.5	74.3	6.15E+05	48.1
Average	1.02	5.68E+05	23.5	74.4	5.81E+05	48.9
% Volume Balance					81.8	
Volume of moist air mix @ outlet (v₂ = actual ft³/lb_m)						13.43
% Mass Balance						81.6

^a fpm = ft/min; acfm = actual ft³/min; and wscf/min = wet standard ft³/min.

Table E-4. Roof Vent Optical Anemometer Results on 2/25/00^a

LOA Time	LOA Reading (actual m/s)	Vol. Air Flow (acfm)	DB Air Temp. (° C)	DB Air Temp. (° F)	Std. Flowrate (wscf/min)	Rel. Humidity (%)
8:45:10	1.03	5.7E+05	23.8	74.8	5.81E+05	49.5
8:46:10	0.99	5.5E+05	23.8	74.8	5.61E+05	49.5
8:47:10	0.96	5.4E+05	23.8	74.8	5.50E+05	49.5
8:48:10	1.06	5.9E+05	23.8	74.8	6.01E+05	49.5
8:49:10	1.02	5.7E+05	23.8	74.8	5.81E+05	49.5
8:50:10	1.00	5.6E+05	23.8	74.8	5.71E+05	49.5
8:51:10	0.97	5.4E+05	23.8	74.8	5.50E+05	49.5
8:52:10	1.04	5.8E+05	23.8	74.8	5.91E+05	49.5
8:53:10	0.95	5.3E+05	23.8	74.8	5.40E+05	49.5
8:54:10	1.06	5.9E+05	23.8	74.8	6.01E+05	49.5
8:55:10	1.11	6.2E+05	23.8	74.8	6.32E+05	49.5
8:56:10	1.11	6.2E+05	23.8	74.8	6.32E+05	49.5
8:57:10	1.07	6.0E+05	23.8	74.8	6.12E+05	49.5
8:58:10	1.06	5.9E+05	23.8	74.8	6.01E+05	49.5
9:00:09	1.04	5.8E+05	24	75.2	5.91E+05	49.7
9:00:10	1.04	5.8E+05	24	75.2	5.91E+05	49.7
Average	1.03	5.7E+05	23.8	74.9	5.87E+05	49.5
% Volume Balance					99.5	
Volume of moist air mix @ outlet (v₂ = actual ft³/lb_m)						13.47
% Mass Balance						98.9

^a fpm = ft/min; acfm = actual ft³/min; and wscf/min = wet standard ft³/min.