

<b>JEFFREY</b>	<b>MINING PRODUCTS</b>	<b>JEFFREY MINING PRODUCTS</b> 274 EAST 1ST AVE. COLUMBUS, OHIO 43201	THIS DRAWING CONTAINS CONFIDENTIAL INFORMATION AND IS THE EXCLUSIVE PROPERTY OF JEFFREY MINING PRODUCTS. NEITHER THE DRAWING OR ITS CONTENTS ARE TO BE USED, REPRODUCED, OR DISCLOSED IN WHOLE OR PART, WITHOUT PRIOR WRITTEN CONSENT FROM JEFFREY MINING PRODUCTS.																
DRAWING NO. <b>538A690</b>		SHEET NO. 1	<b>PART 36 MACHINE APPROVAL NUMBERS THAT USE THIS CHECKLIST:</b> 31-111-0																
DRAWN ROY McKIBBEN	DATE 9/28/87	R E V	A 4/15/88 JVT	B 4/18/97 KRT															
CHECKED ROY McKIBBEN	DATE 9/28/87																		

**MACHINE CHECKLIST**

**MAKE AND MODEL NO. JEFFREY MODEL 4110**

**MACHINE TYPE: RAMCAR SLT**

THIS BLOCK FOR MSHA USE ONLY.
MA# _____
REV LEVEL _____

IF AN MSHA PART 36 APPROVAL PLATE HAS BEEN AFFIXED TO THIS MACHINE, IT MUST MEET THE REQUIREMENTS OF PART 36, TITLE 30, CODE OF FEDERAL REGULATIONS. IT IS THE RESPONSIBILITY OF THE USER TO ENSURE THAT THIS MACHINE IS MAINTAINED IN PERMISSIBLE CONDITION IN ACCORDANCE WITH THIS CHECKLIST.

**ALL INSPECTIONS AND TESTS SHALL BE PERFORMED IN FRESH AIR**

**PERMISSIBILITY:**

- FOR A COMPLETE PERMISSIBILITY EVALUATION, THIS CHECKLIST MUST BE USED IN CONJUNCTION WITH A POWER SYSTEM CHECKLIST AND, IF SO EQUIPPED, AN ELECTRICAL SYSTEM CHECKLIST.
- THE DESIGN OF THE EXHAUST CONDITIONER LIMITS PERMISSIBLE OPERATION TO GRADES NOT EXCEEDING 20%.
- DUE TO BRAKING CAPABILITY LIMITATIONS, THIS MACHINE SHALL NOT BE OPERATED ON GRADES GREATER THAN 30%.

NOTE: WHEN OPERATED IN AREAS WHICH DO NOT REQUIRE PERMISSIBLE MACHINES, THIS MACHINE CAN BE OPERATED ON GRADES GREATER THAN THE 20% GRADE LIMITATION DUE TO THE DESIGN OF THE EXHAUST CONDITIONER, BUT IN NO CASE CAN THE MACHINE BE OPERATED ON GRADES GREATER THAN 30% DUE TO BRAKING CAPABILITY LIMITATIONS.

- THE APPROVAL PLATE SPECIFIES A VENTILATION RATE OF 8700 CFM FOR GASSY NON-COAL MINES AND 5500 CFM FOR COAL MINES.

<b>TEST SHEET TITLE:</b> <b>MACHINE PERMISSIBILITY CHECKLIST</b>					<b>MINE SAFETY &amp; HEALTH ADMINISTRATION</b> <b>APPROVED PRINT. NO DEVIATION OR REVISION IS</b> <b>LEGAL UNTIL APPROVED BY MSHA</b>			
DISTR. CODE SEE DRG.	STD: B	SPECIAL:	ENG. SEC L.	PRINT LOCATION:	DRAWING NUMBER <b>538A690</b>	SHEET NO. 1	OF 10 SHEETS	

<b>JEFFREY</b>		MINING PRODUCTS	JEFFREY MINING PRODUCTS 274 EAST 1ST AVE. COLUMBUS, OHIO 43201		THIS DRAWING CONTAINS CONFIDENTIAL INFORMATION AND IS THE EXCLUSIVE PROPERTY OF JEFFREY MINING PRODUCTS. NEITHER THE DRAWING OR ITS CONTENTS ARE TO BE USED, REPRODUCED, OR DISCLOSED IN WHOLE OR PART, WITHOUT PRIOR WRITTEN CONSENT FROM JEFFREY MINING PRODUCTS.															
DRAWING NO.  <b>538A690</b>			SHEET NO.  2	<b>PART 36 MACHINE APPROVAL NUMBERS THAT USE THIS CHECKLIST:</b> 31-111-0																
DRAWN ROY McKIBBEN		DATE 9/28/87		R E V	A 4/15/88 JVT	B 4/18/97 KRT														
CHECKED ROY McKIBBEN		DATE 9/28/87																		

**A. FUEL SYSTEM:**

- \*1. ( ) THERE ARE NO FUEL LEAKS.
- \*2. ( ) THE FUEL FILLER CAP (1)\*\* IS VENTED AND THE VENT IS NOT PLUGGED. SEE FIGURE 1.
- \*3. ( ) THE FUEL FILLER CAP IS SELF-CLOSING AND IS ATTACHED TO THE TANK IN A MANNER WHICH WILL PREVENT LOSS DURING REFUELING.
- \*4. ( ) AUXILIARY FUEL TANK CAPACITY HAS NOT BEEN ADDED TO THE VEHICLE.
- \*5. ( ) THE FUEL FILLER CAP (2)\*\* IS PROPERLY INSTALLED AND IS NOT DAMAGED.
- \*6. ( ) THE FUEL INJECTION RATE ADJUSTMENT MECHANISM (3)\*\* AND THE ENGINE GOVERNOR SETTING ARE LOCKED AND SEALED. SEE FIGURE 2.

\*(WEEKLY) DESIGNATES THOSE INSPECTION CHECKS THAT MUST BE PERFORMED DURING THE WEEKLY MAINTENANCE EXAMINATION IN ACCORDANCE WITH 30 CFR, SECTION 75.1914.

\*\*REFERENCED ITEMS SHOWN ON MACHINE LAYOUT DIAGRAM (SHEET 10).

<b>TEST SHEET TITLE: MACHINE PERMISSIBILITY CHECKLIST</b>					<b>MINE SAFETY &amp; HEALTH ADMINISTRATION APPROVED PRINT. NO DEVIATION OR REVISION IS LEGAL UNTIL APPROVED BY MSHA</b>			
DISTR. CODE SEE DRG.	STD: B	SPECIAL:	ENG. SEC L.	PRINT LOCATION:	DRAWING NUMBER  <b>538A690</b>	SHEET NO. 2	OF 10 SHEETS	

<b>JEFFREY</b>		MINING PRODUCTS	JEFFREY MINING PRODUCTS 274 EAST 1ST AVE. COLUMBUS, OHIO 43201		THIS DRAWING CONTAINS CONFIDENTIAL INFORMATION AND IS THE EXCLUSIVE PROPERTY OF JEFFREY MINING PRODUCTS. NEITHER THE DRAWING OR ITS CONTENTS ARE TO BE USED, REPRODUCED, OR DISCLOSED IN WHOLE OR PART, WITHOUT PRIOR WRITTEN CONSENT FROM JEFFREY MINING PRODUCTS.															
DRAWING NO. <b>538A690</b>			SHEET NO. 3	<b>PART 36 MACHINE APPROVAL NUMBERS THAT USE THIS CHECKLIST:</b> 31-111-0																
DRAWN ROY McKIBBEN		DATE 9/28/87		R E V	A 4/15/88 JVT	B 4/18/97 KRT														
CHECKED ROY McKIBBEN		DATE 9/28/87																		

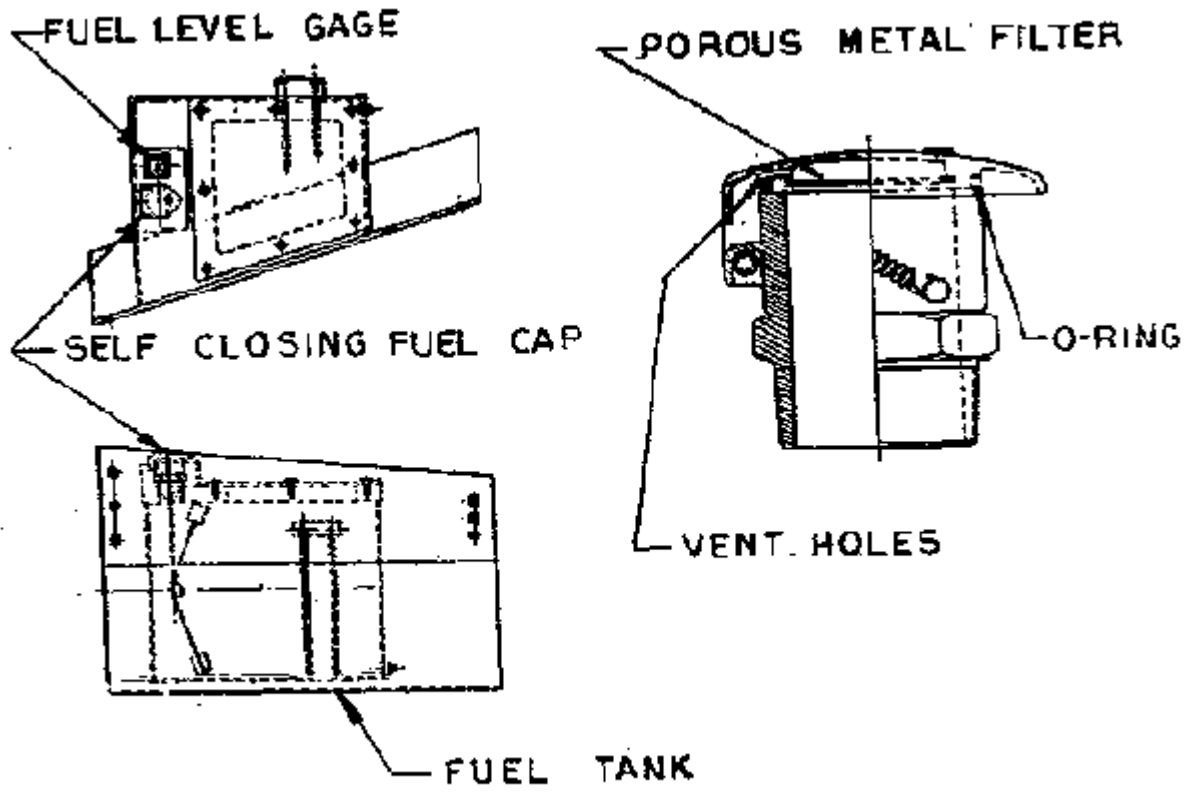

**FIGURE 1**

<b>TEST SHEET TITLE:</b> MACHINE PERMISSIBILITY CHECKLIST					<b>MINE SAFETY &amp; HEALTH ADMINISTRATION</b> APPROVED PRINT. NO DEVIATION OR REVISION IS LEGAL UNTIL APPROVED BY MSHA				
DISTR. CODE SEE DRG.	STD: B	SPECIAL:	ENG. SEC L.	PRINT LOCATION:	DRAWING NUMBER <b>538A690</b>	SHEET NO. 3	OF 10 SHEETS		

<b>JEFFREY</b>		MINING PRODUCTS	JEFFREY MINING PRODUCTS 274 EAST 1ST AVE. COLUMBUS, OHIO 43201		THIS DRAWING CONTAINS CONFIDENTIAL INFORMATION AND IS THE EXCLUSIVE PROPERTY OF JEFFREY MINING PRODUCTS. NEITHER THE DRAWING OR ITS CONTENTS ARE TO BE USED, REPRODUCED, OR DISCLOSED IN WHOLE OR PART, WITHOUT PRIOR WRITTEN CONSENT FROM JEFFREY MINING PRODUCTS.														
DRAWING NO. <b>538A690</b>			SHEET NO. 4	<b>PART 36 MACHINE APPROVAL NUMBERS THAT USE THIS CHECKLIST:</b> 31-111-0															
DRAWN ROY McKIBBEN		DATE 9/28/87		R E V	A 4/15/88 JVT	B 4/18/97 KRT													
CHECKED ROY McKIBBEN		DATE 9/28/87																	

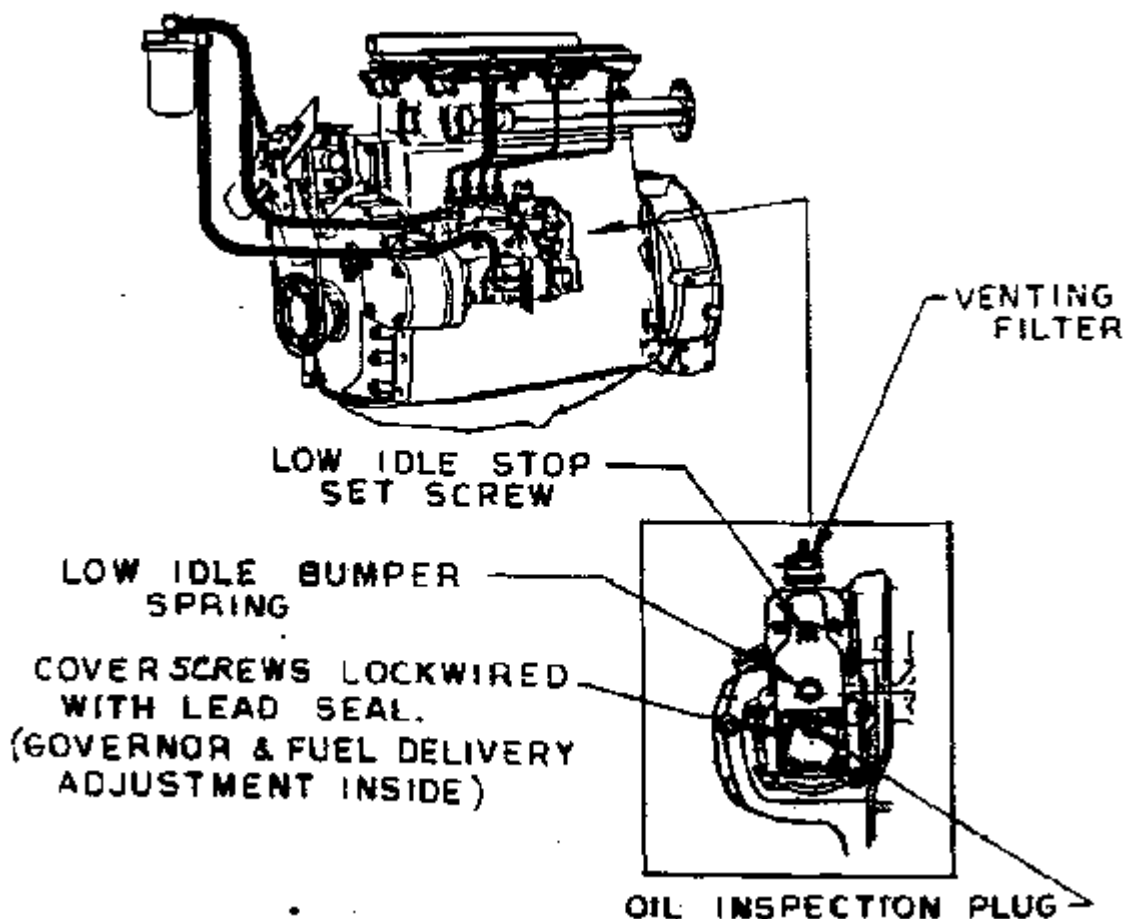

**FIGURE 2**

\*7. ( ) THE FUEL SHUTOFF VALVE (4)\*\* IN THE FUEL SUPPLY LINE IS OPERABLE.

\*8. ( ) THE DRAIN PLUG (5)\*\* IN THE FUEL TANK IS LOCKED IN POSITION. (PIPE PLUGS ARE

TEST SHEET TITLE: MACHINE PERMISSIBILITY CHECKLIST					MINE SAFETY & HEALTH ADMINISTRATION APPROVED PRINT. NO DEVIATION OR REVISION IS LEGAL UNTIL APPROVED BY MSHA			
DISTR. CODE SEE DRG.	STD: B	SPECIAL:	ENG. SEC L.	PRINT LOCATION:	DRAWING NUMBER <b>538A690</b>	SHEET NO. 4	OF 10 SHEETS	

<b>JEFFREY</b>		MINING PRODUCTS	JEFFREY MINING PRODUCTS 274 EAST 1ST AVE. COLUMBUS, OHIO 43201		THIS DRAWING CONTAINS CONFIDENTIAL INFORMATION AND IS THE EXCLUSIVE PROPERTY OF JEFFREY MINING PRODUCTS. NEITHER THE DRAWING OR ITS CONTENTS ARE TO BE USED, REPRODUCED, OR DISCLOSED IN WHOLE OR PART, WITHOUT PRIOR WRITTEN CONSENT FROM JEFFREY MINING PRODUCTS.															
DRAWING NO. <b>538A690</b>			SHEET NO. 5	<b>PART 36 MACHINE APPROVAL NUMBERS THAT USE THIS CHECKLIST:</b> 31-111-0																
DRAWN ROY McKIBBEN		DATE 9/28/87		R E V	A 4/15/88 JVT	B 4/18/97 KRT														
CHECKED ROY McKIBBEN		DATE 9/28/87																		

CONSIDERED "LOCKED IN POSITION" WHEN TIGHT.)

- \*9. ( ) FUEL LINES ARE NOT ROUTED NEAR OR CONNECTED TO HOT EXHAUST COMPONENTS AND ARE PROTECTED FROM EXTERNAL DAMAGE.
- \*10. ( ) FUEL LINES ARE SECURED, SEE FIGURE 3.
- \*11. ( ) THE FUEL FILTER IS PROPERLY INSTALLED AND IS NOT DAMAGED.

\* (WEEKLY) DESIGNATES THOSE INSPECTION CHECKS THAT MUST BE PERFORMED DURING THE WEEKLY MAINTENANCE EXAMINATION IN ACCORDANCE WITH 30 CFR, SECTION 75.1914.

\*\* REFERENCED ITEMS SHOWN ON MACHINE LAYOUT DIAGRAM (SHEET 10).

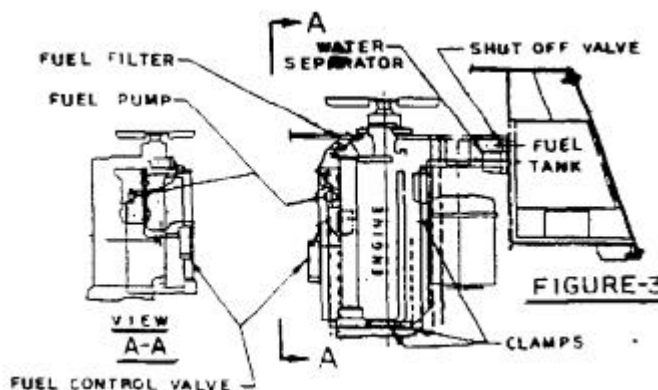

**B. BRAKE SYSTEM:**

**WARNING:** BRAKE TESTS ARE TO BE CONDUCTED ON A RELATIVELY LEVEL SURFACE, AWAY FROM

TEST SHEET TITLE: MACHINE PERMISSIBILITY CHECKLIST					MINE SAFETY & HEALTH ADMINISTRATION APPROVED PRINT. NO DEVIATION OR REVISION IS LEGAL UNTIL APPROVED BY MSHA			
DISTR. CODE SEE DRG.	STD: B	SPECIAL:	ENG. SEC L.	PRINT LOCATION:	DRAWING NUMBER <b>538A690</b>	SHEET NO. 5	OF 10 SHEETS	

<b>JEFFREY</b>		<b>MINING PRODUCTS</b>	JEFFREY MINING PRODUCTS 274 EAST 1ST AVE. COLUMBUS, OHIO 43201		THIS DRAWING CONTAINS CONFIDENTIAL INFORMATION AND IS THE EXCLUSIVE PROPERTY OF JEFFREY MINING PRODUCTS. NEITHER THE DRAWING OR ITS CONTENTS ARE TO BE USED, REPRODUCED, OR DISCLOSED IN WHOLE OR PART, WITHOUT PRIOR WRITTEN CONSENT FROM JEFFREY MINING PRODUCTS.															
DRAWING NO. <b>538A690</b>			SHEET NO. 6	<b>PART 36 MACHINE APPROVAL NUMBERS THAT USE THIS CHECKLIST:</b> 31-111-0																
DRAWN ROY McKIBBEN		DATE 9/28/87		R E V	A 4/15/88 JVT	B 4/18/97 KRT														
CHECKED ROY McKIBBEN		DATE 9/28/87																		

TRAFFIC AREAS WHERE OTHER MACHINES OR PERSONS MAY BE MOVING ABOUT. CONSIDER THE POSSIBLE CONSEQUENCES OF TESTING A MACHINE WITH ASSUMED BRAKING INADEQUACIES, AND SELECT AN AREA WHERE THE TEST MACHINE WOULD NOT CAUSE AN ACCIDENT DUE TO THESE INADEQUACIES.

- \*1. ( ) SERVICE BRAKE TEST:
- A. WITH THE ENGINE OPERATING AND THE MACHINE STATIONARY, APPLY THE SERVICE BRAKE.
  - B. RELEASE ALL OTHER BRAKES.
  - C. PLACE THE TRANSMISSION GEAR SELECTOR IN SECOND GEAR AND THE DIRECTIONAL CONTROL SELECTOR IN FORWARD OR REVERSE.
  - D. DEPRESS THE ACCELERATOR TO FULL THROTTLE, ALLOWING THE ENGINE TO PUT THE TRANSMISSION TORQUE CONVERTER INTO A STALL CONDITION.

IF THE SERVICE BRAKE IS OPERATING SATISFACTORILY, THE UNIT WILL NOT MOVE WHEN THE ABOVE PROCEDURE IS FOLLOWED. IF MOVEMENT IS DETECTED, THE SERVICE BRAKE MUST BE REPAIRED OF ADJUSTED.

\*(WEEKLY) DESIGNATES THOSE INSPECTION CHECKS THAT MUST BE PERFORMED DURING THE WEEKLY MAINTENANCE EXAMINATION IN ACCORDANCE WITH 30 CFR, SECTION 75.1914.

- \*2. ( ) PARKING BRAKE TEST
- A. WITH THE ENGINE OPERATING AND THE MACHINE STATIONARY, APPLY THE PARKING BRAKE (6)\*\*.
  - B. RELEASE ALL OTHER BRAKES.

<b>TEST SHEET TITLE:</b> <b>MACHINE PERMISSIBILTY CHECKLIST</b>					<b>MINE SAFETY &amp; HEALTH ADMINISTRATION</b> <b>APPROVED PRINT. NO DEVIATION OR REVISION IS</b> <b>LEGAL UNTIL APPROVED BY MSHA</b>				
DISTR. CODE SEE DRG.	STD: B	SPECIAL:	ENG. SEC L.	PRINT LOCATION:	DRAWING NUMBER <b>538A690</b>	SHEET NO. 6	OF 10 SHEETS		

<b>JEFFREY</b>		MINING PRODUCTS	JEFFREY MINING PRODUCTS 274 EAST 1ST AVE. COLUMBUS, OHIO 43201		THIS DRAWING CONTAINS CONFIDENTIAL INFORMATION AND IS THE EXCLUSIVE PROPERTY OF JEFFREY MINING PRODUCTS. NEITHER THE DRAWING OR ITS CONTENTS ARE TO BE USED, REPRODUCED, OR DISCLOSED IN WHOLE OR PART, WITHOUT PRIOR WRITTEN CONSENT FROM JEFFREY MINING PRODUCTS.															
DRAWING NO. <b>538A690</b>			SHEET NO. 7	<b>PART 36 MACHINE APPROVAL NUMBERS THAT USE THIS CHECKLIST:</b> 31-111-0																
DRAWN ROY McKIBBEN	DATE 9/28/87			R E V	A 4/15/88 JVT	B 4/18/97 KRT														
CHECKED ROY McKIBBEN	DATE 9/28/87																			

- C. PLACE THE TRANSMISSION GEAR SELECTOR IN SECOND GEAR AND THE DIRECTIONAL CONTROL SELECTOR IN FORWARD OR REVERSE.
- D. ACTUATE THE DECLUTCH BYPASS VALVE LOCATED ON THE LEFT SIDE WALL OF THE OPERATOR'S COMPARTMENT AND HOLD DURING TEST.

**WARNING:** RELEASING THE DECLUTCH BYPASS VALVE DURING TEST WILL CAUSE THE MACHINE TO LURCH IN FORWARD OR REVERSE DIRECTION AS SELECTED. **NOTE:** IF THE DECLUTCH BYPASS VALVE IS RELEASED DURING TEST, THE TEST PROCEDURE MUST BE STARTED AGAIN BEGINNING WITH A.

- E. SHIFT PARK BRAKE LEVER FROM "ON" POSITION TO "AUTO" POSITION.
- F. DEPRESS THE ACCELERATOR TO FULL THROTTLE, ALLOWING THE ENGINE TO PUT THE TRANSMISSION TORQUE CONVERTER INTO A STALL CONDITION.
- G. AFTER TEST, RETURN ENGINE TO LOW IDLE, RELEASE DECLUTCH BYPASS VALVE AND RETURN PARK BRAKE LEVER TO "ON" POSITION.

IF THE PARKING BRAKE IS OPERATING SATISFACTORILY, THE UNIT WILL NOT MOVE WHEN THE ABOVE PROCEDURE IS FOLLOWED. IF MOVEMENT IS DETECTED, THE PARKING BRAKE MUST BE REPAIRED OR ADJUSTED.

\*(WEEKLY) DESIGNATES THOSE INSPECTION CHECKS THAT MUST BE PERFORMED DURING THE WEEKLY MAINTENANCE EXAMINATION IN ACCORDANCE WITH 30 CFR, SECTION 75.1914.

\*\*REFERENCED ITEMS SHOWN ON MACHINE LAYOUT DIAGRAM (SHEET 10).

**C. MISCELLANEOUS:**

- 1. ( ) THE FIRE SUPPRESSION SYSTEM IS OPERABLE AS DETERMINED BY THE FOLLOWING CHECKS.

<b>TEST SHEET TITLE:</b> MACHINE PERMISSIBILITY CHECKLIST					<b>MINE SAFETY &amp; HEALTH ADMINISTRATION</b> APPROVED PRINT. NO DEVIATION OR REVISION IS LEGAL UNTIL APPROVED BY MSHA				
DISTR. CODE SEE DRG.	STD: B	SPECIAL:	ENG. SEC L.	PRINT LOCATION:	DRAWING NUMBER <b>538A690</b>	SHEET NO. 7	OF 10 SHEETS		

<b>JEFFREY</b>		MINING PRODUCTS	JEFFREY MINING PRODUCTS 274 EAST 1ST AVE. COLUMBUS, OHIO 43201		THIS DRAWING CONTAINS CONFIDENTIAL INFORMATION AND IS THE EXCLUSIVE PROPERTY OF JEFFREY MINING PRODUCTS. NEITHER THE DRAWING OR ITS CONTENTS ARE TO BE USED, REPRODUCED, OR DISCLOSED IN WHOLE OR PART, WITHOUT PRIOR WRITTEN CONSENT FROM JEFFREY MINING PRODUCTS.															
DRAWING NO.  <b>538A690</b>			SHEET NO.  8	<b>PART 36 MACHINE APPROVAL NUMBERS THAT USE THIS CHECKLIST:</b> 31-111-0																
DRAWN ROY McKIBBEN	DATE 9/28/87			R E V	A 4/15/88 JVT	B 4/18/97 KRT														
CHECKED ROY McKIBBEN	DATE 9/28/87																			

- A. NOTE GENERAL APPEARANCE OF SYSTEM COMPONENTS FOR MECHANICAL DAMAGE OR CORROSION.
- B. CHECK NAMEPLATE(S) FOR READABILITY.
- C. REMOVE FILL CAP FROM DRY CHEMICAL TANKS (7)\*\*.
- D. MAKE CERTAIN TANK IS FILLED WITH FREE-FLOWING DRY CHEMICAL TO A LEVEL OF NOT MORE THAN 3 INCHES FROM THE BOTTOM OF THE FILL OPENING.
- E. SECURE FILL CAP, HAND TIGHTEN.
- F. REMOVE EXPELLANT GAS CARTRIDGE AND EXAMINE DISC- SEAL SHOULD BE UNRUPTURED.
- G. RETURN CARTRIDGE TO PNEUMATIC ACTUATOR/CARTRIDGE RECEIVER, HAND TIGHTEN AND SECURE IN BRACKET.
- H. CHECK HOSE, FITTINGS AND NOZZLES FOR MECHANICAL DAMAGE AND CUTS.
- I. CHECK NOZZLE OPENINGS - SLOT ON NOZZLE SHOULD BE CLOSED (CAPPED) WITH SILICONE GREASE OR COVERED WITH PLASTIC BLOW-OFF CAP.

\*\*REFERENCED ITEMS SHOWN ON MACHINE LAYOUT DIAGRAM (SHEET 10).

**C. MISCELLANEOUS: (cont.)**

- J. REMOVE CARTRIDGE FROM MANUAL ACTUATOR(S), AND EXAMINE DISC - SEAL SHOULD BE UNRUPTURED.
- K. RETURN CARTRIDGE TO MANUAL ACTUATOR(S) ASSEMBLY, HAND TIGHTEN.

<b>TEST SHEET TITLE:</b> MACHINE PERMISSIBILTY CHECKLIST					<b>MINE SAFETY &amp; HEALTH ADMINISTRATION</b> APPROVED PRINT. NO DEVIATION OR REVISION IS LEGAL UNTIL APPROVED BY MSHA				
DISTR. CODE SEE DRG.	STD: B	SPECIAL:	ENG. SEC L.	PRINT LOCATION:	DRAWING NUMBER  <b>538A690</b>	SHEET NO. 8	OF 10 SHEETS		



<b>JEFFREY</b>		MINING PRODUCTS	JEFFREY MINING PRODUCTS 274 EAST 1ST AVE. COLUMBUS, OHIO 43201		THIS DRAWING CONTAINS CONFIDENTIAL INFORMATION AND IS THE EXCLUSIVE PROPERTY OF JEFFREY MINING PRODUCTS. NEITHER THE DRAWING OR ITS CONTENTS ARE TO BE USED, REPRODUCED, OR DISCLOSED IN WHOLE OR PART, WITHOUT PRIOR WRITTEN CONSENT FROM JEFFREY MINING PRODUCTS.															
DRAWING NO. <b>538A690</b>			SHEET NO. 9	<b>PART 36 MACHINE APPROVAL NUMBERS THAT USE THIS CHECKLIST:</b> 31-111-0																
DRAWN ROY McKIBBEN		DATE 9/28/87		R E V	A 4/15/88 JVT	B 4/18/97 KRT														
CHECKED ROY McKIBBEN		DATE 9/28/87																		

L. REPLACE ANY BROKEN OR MISSING LEAD AND WIRE SEALS.

\*M. CHECK TO ENSURE THE MACHINE IS EQUIPPED WITH A 4A10BCNFPA FIRE EXTINGUISHER. CHECK FIRE EXTINGUISHER PRESSURE INDICATOR TO SEE THAT IT IS FULLY CHARGED.

- \*2. ( ) THE MAIN AIR PRESSURE GAUGE IN THE OPERATOR'S COMPARTMENT IS OPERABLE.
- \*3. ( ) THE MACHINE HAS AN MSHA PART 36 APPROVAL PLATE (8)\* ATTACHED TO IT IN THE OPERATOR'S COMPARTMENT.
- \*4. ( ) THE ENGINE WILL NOT TURN OVER UNLESS THE DIRECTIONAL CONTROL SELECTOR IS IN THE NEUTRAL POSITION.
- \*5. ( ) THE EXHAUST DIFFUSER AT THE SCRUBBER OUTLET IS INSTALLED.
- \*6. ( ) ALL FLUID STORAGE TANKS ARE CHECKED AND THERE ARE NO LEAKS.
- \*7. ( ) CHECK TRAILER FUEL SHUTOFF EMERGENCY STOP SWITCH TO SEE THAT IT SHUTS OFF ENGINE

\*(WEEKLY) DESIGNATES THOSE INSPECTION CHECKS THAT MUST BE PERFORMED DURING THE WEEKLY MAINTENANCE EXAMINATION IN ACCORDANCE WITH 30 CFR, SECTION 75.1914.

\*\*REFERENCED ITEMS SHOWN ON MACHINE LAYOUT DIAGRAM (SHEET 10).

<b>TEST SHEET TITLE: MACHINE PERMISSIBILITY CHECKLIST</b>					<b>MINE SAFETY &amp; HEALTH ADMINISTRATION APPROVED PRINT. NO DEVIATION OR REVISION IS LEGAL UNTIL APPROVED BY MSHA</b>			
DISTR. CODE SEE DRG.	STD: B	SPECIAL:	ENG. SEC L.	PRINT LOCATION:	DRAWING NUMBER <b>538A690</b>	SHEET NO. 9	OF 10 SHEETS	

<b>JEFFREY</b>	MINING PRODUCTS	JEFFREY MINING PRODUCTS	THIS DRAWING CONTAINS CONFIDENTIAL INFORMATION AND IS THE EXCLUSIVE PROPERTY OF JEFFREY MINING PRODUCTS. NEITHER THE DRAWING OR ITS CONTENTS ARE TO BE USED, REPRODUCED, OR DISCLOSED IN WHOLE OR PART, WITHOUT PRIOR WRITTEN CONSENT FROM JEFFREY MINING PRODUCTS.			
		274 EAST 1ST AVE. COLUMBUS, OHIO 43201				

DRAWING NO. <b>538A690</b>		SHEET NO. 10	<b>PART 36 MACHINE APPROVAL NUMBERS THAT USE THIS CHECKLIST:</b> 31-111-0			
DRAWN ROY McKIBBEN	DATE 9/28/87	REV A 4/15/88 JVT	B 4/18/97 KRT			
CHECKED ROY McKIBBEN	DATE 9/28/87					

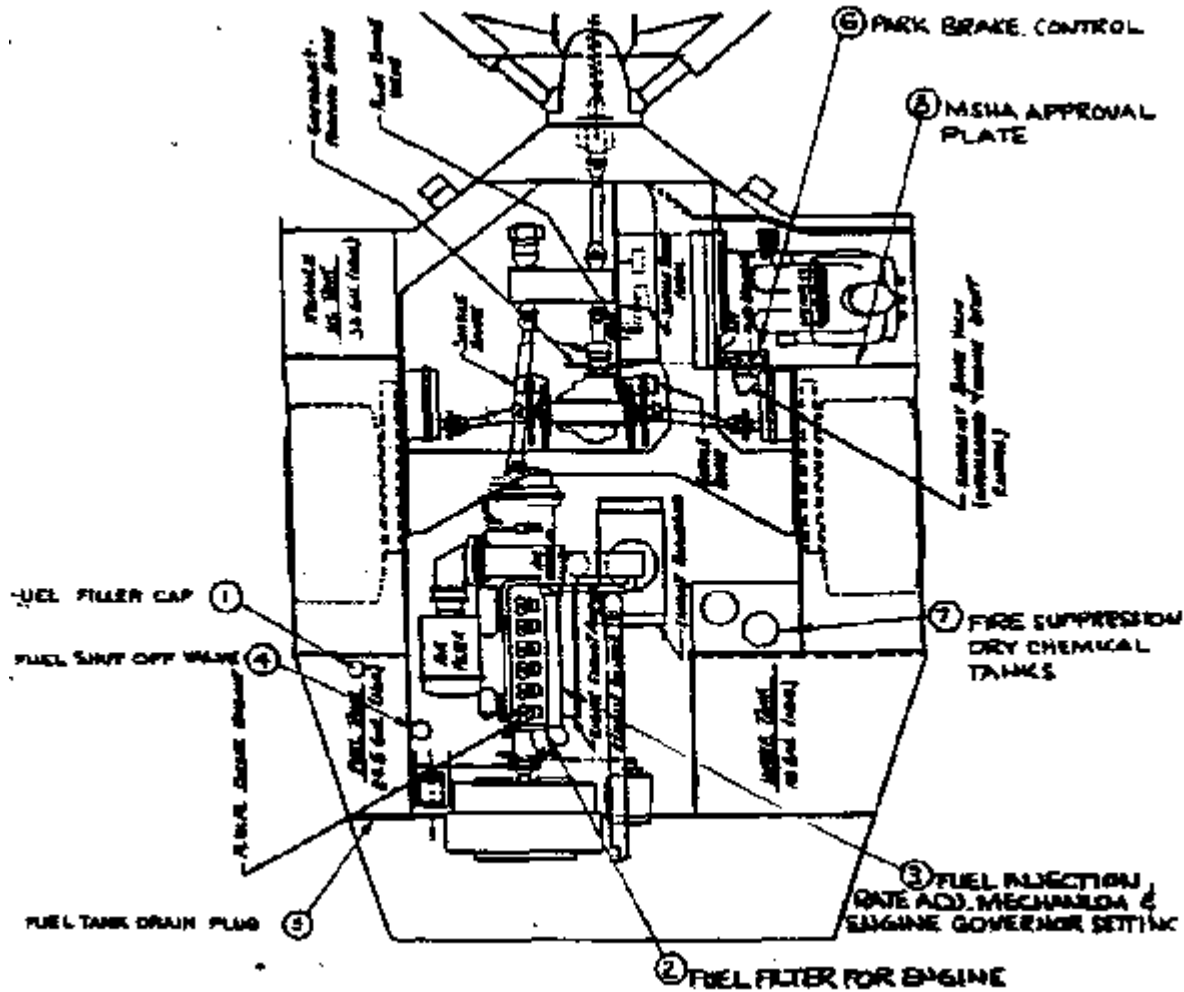

<b>TEST SHEET TITLE:</b> MACHINE PERMISSIBILITY CHECKLIST					<b>MINE SAFETY &amp; HEALTH ADMINISTRATION</b> APPROVED PRINT. NO DEVIATION OR REVISION IS LEGAL UNTIL APPROVED BY MSHA		
DISTR. CODE SEE DRG.	STD: B	SPECIAL:	ENG. SEC L.	PRINT LOCATION:	DRAWING NUMBER <b>538A690</b>	SHEET NO. 10	OF 10 SHEETS