

NIST NCSTAR 1-4 (Draft)

**Federal Building and Fire Safety Investigation of the
World Trade Center Disaster**

Active Fire Protection Systems (Draft)

David D. Evans
Erica D. Kuligowski
W. Stuart Dols
William L. Grosshandler

For Public Comment

NIST NCSTAR 1-4 (Draft)

For Public Comment

Federal Building and Fire Safety Investigation of the World Trade Center Disaster

Active Fire Protection Systems (Draft)

David D. Evans
Society of Fire Protection Engineers

Erica D. Kuligowski
W. Stuart Dols
William L. Grosshandler
*Building and Fire Research Laboratory
National Institute of Standards and Technology*

September 2005



U.S. Department of Commerce
Carlos M. Gutierrez, Secretary

Technology Administration
Michelle O'Neill, Acting Under Secretary for Technology

National Institute of Standards and Technology
Hratch G. Semerjian, Acting Director

Disclaimer No. 1

Certain commercial entities, equipment, products, or materials are identified in this document in order to describe a procedure or concept adequately or to trace the history of the procedures and practices used. Such identification is not intended to imply recommendation, endorsement, or implication that the entities, products, materials, or equipment are necessarily the best available for the purpose. Nor does such identification imply a finding of fault or negligence by the National Institute of Standards and Technology.

Disclaimer No. 2

The policy of NIST is to use the International System of Units (metric units) in all publications. In this document, however, units are presented in metric units or the inch-pound system, whichever is prevalent in the discipline.

Disclaimer No. 3

Pursuant to section 7 of the National Construction Safety Team Act, the NIST Director has determined that certain evidence received by NIST in the course of this Investigation is "voluntarily provided safety-related information" that is "not directly related to the building failure being investigated" and that "disclosure of that information would inhibit the voluntary provision of that type of information" (15 USC 7306c).

In addition, a substantial portion of the evidence collected by NIST in the course of the Investigation has been provided to NIST under nondisclosure agreements.

Disclaimer No. 4

NIST takes no position as to whether the design or construction of a WTC building was compliant with any code since, due to the destruction of the WTC buildings, NIST could not verify the actual (or as-built) construction, the properties and condition of the materials used, or changes to the original construction made over the life of the buildings. In addition, NIST could not verify the interpretations of codes used by applicable authorities in determining compliance when implementing building codes. Where an Investigation report states whether a system was designed or installed as required by a code *provision*, NIST has documentary or anecdotal evidence indicating whether the requirement was met, or NIST has independently conducted tests or analyses indicating whether the requirement was met.

Use in Legal Proceedings

No part of any report resulting from a NIST investigation into a structural failure or from an investigation under the National Construction Safety Team Act may be used in any suit or action for damages arising out of any matter mentioned in such report (15 USC 281a; as amended by P.L. 107-231).

**National Institute of Standards and Technology National Construction Safety Team Act Report 1-4 (Draft)
Natl. Inst. Stand. Technol. Natl. Constr. Sfty. Tm. Act Rpt. 1-4 (Draft), 138 pages (September 2005)
CODEN: NSPUE2**

U.S. GOVERNMENT PRINTING OFFICE
WASHINGTON: 2005

For sale by the Superintendent of Documents, U.S. Government Printing Office
Internet: bookstore.gpo.gov — Phone: (202) 512-1800 — Fax: (202) 512-2250
Mail: Stop SSOP, Washington, DC 20402-0001

ABSTRACT

The National Institute of Standards and Technology investigation of active fire protection systems in World Trade Center (WTC) 1, 2, and 7 included the design, installation, capabilities, and performance on September 11, 2001, of the automatic fire sprinkler, standpipe, standpipe preconnected hoses, fire alarm, and smoke management systems. The purpose and normally expected performance of each active fire protection system in the buildings are described, as well as details about the systems installed in WTC 1, 2, and 7. Using fire protection engineering methods, the capabilities of the installed systems to respond to various fire threats from normal office fires up to and including the extraordinary challenge of the fires ignited by the aircraft impacts on September 11, 2001, were assessed. Information from The Fire Department of the City of New York records was used to document the history of significant fire events in WTC 1, 2, and 7. Findings of the investigation are presented with regard to the fire suppression, fire alarm, and smoke management systems installed on the day the buildings collapsed.

Keywords: Fire alarm systems, fire protection engineering, fire protection systems, hydraulic calculations, smoke detection, smoke management, smoke purge, sprinklers, standpipes, voice communication, World Trade Center.

This page intentionally left blank.

TABLE OF CONTENTS

Abstract	iii
List of Figures	ix
List of Tables	xi
List of Acronyms and Abbreviations	xiii
Metric Conversion Table	xv
Preface	xvii
Acknowledgments.....	xxvii
Executive Summary	xxix
Chapter 1	
Objectives and Approach.....	1
1.1 Objectives	1
1.2 Approach.....	1
1.3 Report Organization.....	3
Chapter 2	
Significant Fires in WTC 1, 2, and 7 Prior to September 11, 2001	5
2.1 FDNY Records	5
2.2 Significant Fires	5
Chapter 3	
Sprinklers, Standpipes, and Preconnected Hose Systems	9
3.1 Automatic Fire Sprinkler Systems	9
3.2 Standpipes and Preconnected Hoses	11
3.3 NYC Water Supply	12
3.4 WTC 1 and WTC 2 Installed Fire Suppression Features	14
3.4.1 Overview	14
3.4.2 Details of the Sprinkler and Standpipe Riser System.....	16
3.5 WTC 7 Installed Fire Suppression Features	23
3.5.1 Overview	23
3.5.2 Details of the Standpipe and Sprinkler Riser Systems	24
3.6 Consistency With Engineering Best Practices	30
3.7 WTC 1, 2, and 7 Suppression System Installation Differences	30

3.8	Water Supply Capacities for WTC 1, 2, and 7 Sprinkler Systems	31
3.9	Suppression System Performance Under Selected Fire Scenarios	33
3.9.1	Scenarios	33
3.9.2	Results	35
3.10	Estimates of Suppression Systems Performance on September 11, 2001	37
3.11	Summary of Findings.....	40
Chapter 4		
	Fire Alarm Systems	43
4.1	WTC 1 and WTC 2 Fire Alarm Systems	43
4.1.1	History	43
4.1.2	Building and Fire Prevention Codes.....	45
4.1.3	FCS and Alarm System Installation and Functions.....	45
4.1.4	Fire Alarm System Design	47
4.2	WTC 7 Fire Alarm System	57
4.2.1	History	57
4.2.2	System Arrangement	58
4.2.3	System Architecture and Operation.....	59
4.2.4	Design and Installation	60
4.2.5	Inspection, Testing, and Maintenance	60
4.3	Comparison of WTC 7 Fire Alarm System to WTC 1 and WTC 2 Fire Alarm System.....	61
4.4	Fire Emergency Response.....	62
4.5	System Performance on September 11, 2001	63
4.5.1	WTC 1 and WTC 2 Observations	63
4.5.2	WTC 7 Observations	66
4.6	Summary of Findings.....	67
Chapter 5		
	Smoke Management Systems	69
5.1	Introduction to Smoke Management.....	69
5.1.1	Smoke Management Methods	69
5.1.2	History of Smoke Management.....	71
5.1.3	Applicable Codes and Standards	72
5.2	Building Descriptions	73
5.2.1	WTC 1 and WTC 2	74
5.2.2	WTC 7	78

- 5.3 Smoke Management System Design and Installation..... 81
 - 5.3.1 WTC 1 and WTC 2 81
 - 5.3.2 WTC 7 85
- 5.4 Evaluation of System Performance on September 11, 2001..... 85
 - 5.4.1 Actions of Emergency Response Personnel 86
 - 5.4.2 Damage to System Components..... 86
 - 5.4.3 Summary of System Performance on September 11, 2001 86
- 5.5 Evaluation of Potential Smoke Management System Effectiveness..... 87
 - 5.5.1 Smoke Management System Approaches 88
 - 5.5.2 Design Fire Scenarios..... 89
 - 5.5.3 Results of the Analysis 90
- 5.6 Summary of Results 91

- Chapter 6
 - Active Fire Protection Systems: Summary of Investigation Findings 93**
 - 6.1 Minimum Level of Performance for Active Fire Protection Systems Hardware..... 94
 - 6.1.1 Fire Suppression Systems and Water Supply 94
 - 6.1.2 Building Fire Alarm and Communications Systems 95
 - 6.1.3 Smoke Management Systems..... 96
 - 6.2 Quantity and Reliability of Information Available 96
 - 6.2.1 For Fire Status Monitoring and Fire Fighting Activities 96
 - 6.2.2 For Assisting Evacuation..... 97
 - 6.2.3 For Investigative Purposes 97

- Chapter 7
 - References..... 99**

This page intentionally left blank.

LIST OF FIGURES

Figure P-1.	The eight projects in the federal building and fire safety investigation of the WTC disaster.	xix
Figure 3-1.	Typical sprinkler installed in ceiling.....	10
Figure 3-2.	Plan of water distribution system surrounding the WTC complex.	13
Figure 3-3.	Typical 5,000 gal water storage tank, WTC 1 and WTC 2.....	15
Figure 3-4.	WTC 1 and WTC 2 sprinkler and standpipe risers.	17
Figure 3-5.	Typical hose rack arrangement.	20
Figure 3-6.	Typical floor control valve assembly.....	22
Figure 3-7.	Typical concealed pendent sprinkler.....	23
Figure 3-8.	WTC 7 water riser schematic.....	25
Figure 3-9.	Floor control valve and fire hose valve/cabinet locations, WTC 7.....	27
Figure 4-1.	WTC 1 FCS with functions of the alarm and control panels labeled.....	48
Figure 4-2.	Typical WTC 1 and WTC 2 core and quadrants.....	49
Figure 4-3.	Standard fire alarm equipment and device locations.	50
Figure 4-4.	XNET network configuration single-line schematic.....	52
Figure 4-5.	Notification appliance network single-line schematic.	53
Figure 4-6.	Floor warden and firefighter telephone single-line schematic.	54
Figure 4-7.	MNET network configuration single-line schematic.....	55
Figure 4-8.	Typical WTC 1 riser locations on impact floors.....	56
Figure 4-9.	Typical WTC 2 riser locations on impact floors.....	57
Figure 4-10.	Fire alarm system displays at the FCS in WTC 1 showing conditions speaker and telephone circuit faults existing in WTC 2.	65
Figure 4-11.	Monitoring station history tape record for the WTC 7 fire alarm system on September 11, 2001.	66
Figure 5-1.	Positive (left side) and negative (right side) pressurization smoke management systems.....	70
Figure 5-2.	Floor layout, 95th floor, WTC 1, North Tower.....	75
Figure 5-3.	Floor layout, 80th Floor, WTC 2, South Tower.....	76
Figure 5-4.	Location of MERs, WTC 1 and WTC 2.	77
Figure 5-5.	Floor layout, 24th floor, WTC 7.	79

Figure 5–6. Air distribution system, 24th floor, WTC 7. 80

Figure 5–7. Air distribution system, 80th floor, WTC 2. 84

LIST OF TABLES

Table P-1.	Federal building and fire safety investigation of the WTC disaster.....	xviii
Table P-2.	Public meetings and briefings of the WTC Investigation.	xxi
Table 2-1.	Summary of historical fires in WTC 1, 2, and 7.	6
Table 3-1.	Standpipe designations and locations, WTC 1 and WTC 2.	19
Table 3-2.	Standpipe system zones, WTC 1 and WTC 2.	21
Table 3-3.	WTC 1 and WTC 2 sprinkler system risers.	22
Table 3-4.	Results of hydraulic calculations.	32
Table 3-5.	Average delivered density per floor vs. number of floors flowing (four sprinklers/floor).....	36
Table 3-6.	Average delivered density per floor vs. number of floors flowing (nine sprinklers/floor) for WTC 1 and WTC 2.....	36
Table 3-7.	Damage estimates to WTC 1 from aircraft impact.	38
Table 3-8.	Damage estimates to WTC 2 from aircraft impact.	39

This page intentionally left blank.

LIST OF ACRONYMS AND ABBREVIATIONS

Acronyms

AFA	AFA Protective Services
ASHRAE	American Society of Heating, Refrigerating and Air-Conditioning Engineers
BBFAS	Base Building Fire Alarm System
BCNYC	Building Code of the City of New York
BWS	Bureau of Water Supply
BWSO	Bureau of Water Sewer Operations
DEP	Department of Environmental Protection
EMR	elevator machine room
FCA	floor control assembly (sprinkler system)
FCS	Fire Command Station
FDC	fire department connection
FDNY	The Fire Department of the City of New York
FEMA	Federal Emergency Management Agency
FHC	fire hose cabinet
FHV	fire hose value
HAI	Hughes Associates, Inc.
HVAC	heating, ventilation, and air-conditioning
MER	mechanical equipment room
NBFU	National Board of Fire Underwriters
NCC	network command center (fire alarm system)
NFPA	National Fire Protection Association
NIST	National Institute of Standards and Technology
NYC	New York City
OCC	Operations Command Center
O&M	Operations and Maintenance
PANYNJ	Port Authority of New York and New Jersey
PSR	Power Supply Remote
RJA	Rolf Jensen and Associates, Inc.

SSB	Salomon Smith Barney
TTB	Terminal Transmission Box
USC	United States Code
WTC	World Trade Center
WTC 1	World Trade Center 1 (North Tower)
WTC 2	World Trade Center 2 (South Tower)
WTC 7	World Trade Center 7

Abbreviations

°C	degrees Celsius
°F	degrees Fahrenheit
µm	micrometer
CO ₂	carbon dioxide
ft	foot
ft ²	square foot
gal	gallon
gpm	gallons per minute
h	hour
hp	horsepower
in.	inch
in. H ₂ O	inches of water column (unit of pressure)
L	liter
m	meter
m ³	cubic meters
mi	mile
min	minute
Pa	Pascal (unit of pressure)
psi	pounds per square inch
s	second
t ²	square ton
V	volt

METRIC CONVERSION TABLE

To convert from	to	Multiply by
-----------------	----	-------------

AREA AND SECOND MOMENT OF AREA

square foot (ft ²)	square meter (m ²)	9.290 304 E-02
square inch (in. ²)	square meter (m ²)	6.4516 E-04
square inch (in. ²)	square centimeter (cm ²)	6.4516 E+00
square yard (yd ²)	square meter (m ²)	8.361 274 E-01

FORCE DIVIDED BY LENGTH

pound-force per foot (lbf/ft)	newton per meter (N/m)	1.459 390 E+01
pound-force per inch (lbf/in.)	newton per meter (N/m)	1.751 268 E+02

LENGTH

foot (ft)	meter (m)	3.048 E-01
inch (in)	meter (m)	2.54 E-02
inch (in.)	centimeter (cm)	2.54 E+00
micron (m)	meter (m)	1.0 E-06
yard (yd)	meter (m)	9.144 E-01

MASS and MOMENT OF INERTIA

kilogram-force second squared per meter (kgf · s ² /m)	kilogram (kg)	9.806 65 E+00
pound foot squared (lb · ft ²)	kilogram meter squared (kg · m ²)	4.214 011 E-02
pound inch squared (lb · in. ²)	kilogram meter squared (kg · m ²)	2.926 397 E-04
ton, metric (t)	kilogram (kg)	1.0 E+03
ton, short (2,000 lb)	kilogram (kg)	9.071 847 E+02

MASS DIVIDED BY AREA

pound per square foot (lb/ft ²)	kilogram per square meter (kg/m ²)	4.882 428 E+00
pound per square inch (not pound force) (lb/in. ²)	kilogram per square meter (kg/m ²)	7.030 696 E+02

MASS DIVIDED BY LENGTH

pound per foot (lb/ft)	kilogram per meter (kg/m)	1.488 164 E+00
pound per inch (lb/in.)	kilogram per meter (kg/m)	1.785 797 E+01
pound per yard (lb/yd)	kilogram per meter (kg/m)	4.960 546 E-01

PRESSURE or STRESS (FORCE DIVIDED BY AREA)

kilogram-force per square centimeter (kgf/cm ²)	pascal (Pa)	9.806 65 E+04
kilogram-force per square meter (kgf/m ²)	pascal (Pa)	9.806 65 E+00
kilogram-force per square millimeter (kgf/mm ²)	pascal (Pa)	9.806 65 E+06
kip per square inch (ksi) (kip/in. ²)	pascal (Pa)	6.894 757 E+06
kip per square inch (ksi) (kip/in. ²)	kilopascal (kPa)	6.894 757 E+03
pound-force per square foot (lbf/ft ²)	pascal (Pa)	4.788 026 E+01
pound-force per square inch (psi) (lbf/in. ²)	pascal (Pa)	6.894 757 E+03
pound-force per square inch (psi) (lbf/in. ²)	kilopascal (kPa)	6.894 757 E+00
psi (pound-force per square inch) (lbf/in. ²)	pascal (Pa)	6.894 757 E+03
psi (pound-force per square inch) (lbf/in. ²)	kilopascal (kPa)	6.894 757 E+00

TEMPERATURE

degree Celsius (°C)	kelvin (K)	$T/K = t/^{\circ}C + 273.15$
degree centigrade	degree Celsius (°C)	$t/^{\circ}C \approx t / \text{deg. cent.}$
degree Fahrenheit (°F)	degree Celsius (°C)	$t/^{\circ}C = (t/^{\circ}F - 32)/1.8$
degree Fahrenheit (°F)	kelvin (K)	$T/K = (t/^{\circ}F + 459.67)/1.8$
kelvin (K)	degree Celsius (°C)	$t/^{\circ}C = T/K - 273.15$

VELOCITY (includes SPEED)

foot per second (ft/s)	meter per second (m/s)	3.048 E-01
inch per second (in./s)	meter per second (m/s)	2.54 E-02
kilometer per hour (km/h)	meter per second (m/s)	2.777 778 E-01
mile per hour (mi/h)	kilometer per hour (km/h)	1.609 344 E+00
mile per minute (mi/min)	meter per second (m/s)	2.682 24 E+01

VOLUME (includes CAPACITY)

cubic foot (ft ³)	cubic meter (m ³)	2.831 685 E-02
cubic inch (in. ³)	cubic meter (m ³)	1.638 706 E-05
cubic yard (yd ³)	cubic meter (m ³)	7.645 549 E-01
gallon (U.S.) (gal)	cubic meter (m ³)	3.785 412 E-03
gallon (U.S.) (gal)	liter (L)	3.785 412 E+00
liter (L)	cubic meter (m ³)	1.0 E-03
ounce (U.S. fluid) (fl oz)	cubic meter (m ³)	2.957 353 E-05
ounce (U.S. fluid) (fl oz)	milliliter (mL)	2.957 353 E+01

PREFACE

Genesis of This Investigation

Immediately following the terrorist attack on the World Trade Center (WTC) on September 11, 2001, the Federal Emergency Management Agency (FEMA) and the American Society of Civil Engineers began planning a building performance study of the disaster. The week of October 7, as soon as the rescue and search efforts ceased, the Building Performance Study Team went to the site and began their assessment. This was to be a brief effort, as the study team consisted of experts who largely volunteered their time away from their other professional commitments. The Building Performance Study Team issued their report in May 2002, fulfilling their goal “to determine probable failure mechanisms and to identify areas of future investigation that could lead to practical measures for improving the damage resistance of buildings against such unforeseen events.”

On August 21, 2002, with funding from the U.S. Congress through FEMA, the National Institute of Standards and Technology (NIST) announced its building and fire safety investigation of the WTC disaster. On October 1, 2002, the National Construction Safety Team Act (Public Law 107-231), was signed into law. The NIST WTC Investigation was conducted under the authority of the National Construction Safety Team Act.

The goals of the investigation of the WTC disaster were:

- To investigate the building construction, the materials used, and the technical conditions that contributed to the outcome of the WTC disaster.
- To serve as the basis for:
 - Improvements in the way buildings are designed, constructed, maintained, and used;
 - Improved tools and guidance for industry and safety officials;
 - Recommended revisions to current codes, standards, and practices; and
 - Improved public safety.

The specific objectives were:

1. Determine why and how WTC 1 and WTC 2 collapsed following the initial impacts of the aircraft and why and how WTC 7 collapsed;
2. Determine why the injuries and fatalities were so high or low depending on location, including all technical aspects of fire protection, occupant behavior, evacuation, and emergency response;
3. Determine what procedures and practices were used in the design, construction, operation, and maintenance of WTC 1, 2, and 7; and
4. Identify, as specifically as possible, areas in current building and fire codes, standards, and practices that warrant revision.

NIST is a nonregulatory agency of the U.S. Department of Commerce’s Technology Administration. The purposes of NIST investigations under the National Construction Safety Team Act are to improve the safety and structural integrity of buildings in the United States, and the focus is on fact finding. NIST investigative teams are required to assess building performance and emergency response and evacuation procedures in the wake of any building failure that has resulted in substantial loss of life or that posed significant potential of substantial loss of life. NIST does not have the statutory authority to make findings of fault or negligence by individuals or organizations. Further, no part of any report resulting from a NIST investigation into a building failure or from an investigation under the National Construction Safety Team Act may be used in any suit or action for damages arising out of any matter mentioned in such report (15 USC 281a, as amended by Public Law 107-231).

Organization of the Investigation

The National Construction Safety Team for this Investigation, appointed by the NIST Director, was led by Dr. S. Shyam Sunder. Dr. William L. Grosshandler served as Associate Lead Investigator, Mr. Stephen A. Cauffman served as Program Manager for Administration, and Mr. Harold E. Nelson served on the team as a private sector expert. The Investigation included eight interdependent projects whose leaders comprised the remainder of the team. A detailed description of each of these eight projects is available at <http://wtc.nist.gov>. The purpose of each project is summarized in Table P–1, and the key interdependencies among the projects are illustrated in Figure P–1.

Table P–1. Federal building and fire safety investigation of the WTC disaster.

Technical Area and Project Leader	Project Purpose
Analysis of Building and Fire Codes and Practices; Project Leaders: Dr. H. S. Lew and Mr. Richard W. Bukowski	Document and analyze the code provisions, procedures, and practices used in the design, construction, operation, and maintenance of the structural, passive fire protection, and emergency access and evacuation systems of WTC 1, 2, and 7.
Baseline Structural Performance and Aircraft Impact Damage Analysis; Project Leader: Dr. Fahim H. Sadek	Analyze the baseline performance of WTC 1 and WTC 2 under design, service, and abnormal loads, and aircraft impact damage on the structural, fire protection, and egress systems.
Mechanical and Metallurgical Analysis of Structural Steel; Project Leader: Dr. Frank W. Gayle	Determine and analyze the mechanical and metallurgical properties and quality of steel, weldments, and connections from steel recovered from WTC 1, 2, and 7.
Investigation of Active Fire Protection Systems; Project Leader: Dr. David D. Evans	Investigate the performance of the active fire protection systems in WTC 1, 2, and 7 and their role in fire control, emergency response, and fate of occupants and responders.
Reconstruction of Thermal and Tenability Environment; Project Leader: Dr. Richard G. Gann	Reconstruct the time-evolving temperature, thermal environment, and smoke movement in WTC 1, 2, and 7 for use in evaluating the structural performance of the buildings and behavior and fate of occupants and responders.
Structural Fire Response and Collapse Analysis; Project Leaders: Dr. John L. Gross and Dr. Therese P. McAllister	Analyze the response of the WTC towers to fires with and without aircraft damage, the response of WTC 7 in fires, the performance of composite steel-trussed floor systems, and determine the most probable structural collapse sequence for WTC 1, 2, and 7.
Occupant Behavior, Egress, and Emergency Communications; Project Leader: Mr. Jason D. Averill	Analyze the behavior and fate of occupants and responders, both those who survived and those who did not, and the performance of the evacuation system.
Emergency Response Technologies and Guidelines; Project Leader: Mr. J. Randall Lawson	Document the activities of the emergency responders from the time of the terrorist attacks on WTC 1 and WTC 2 until the collapse of WTC 7, including practices followed and technologies used.

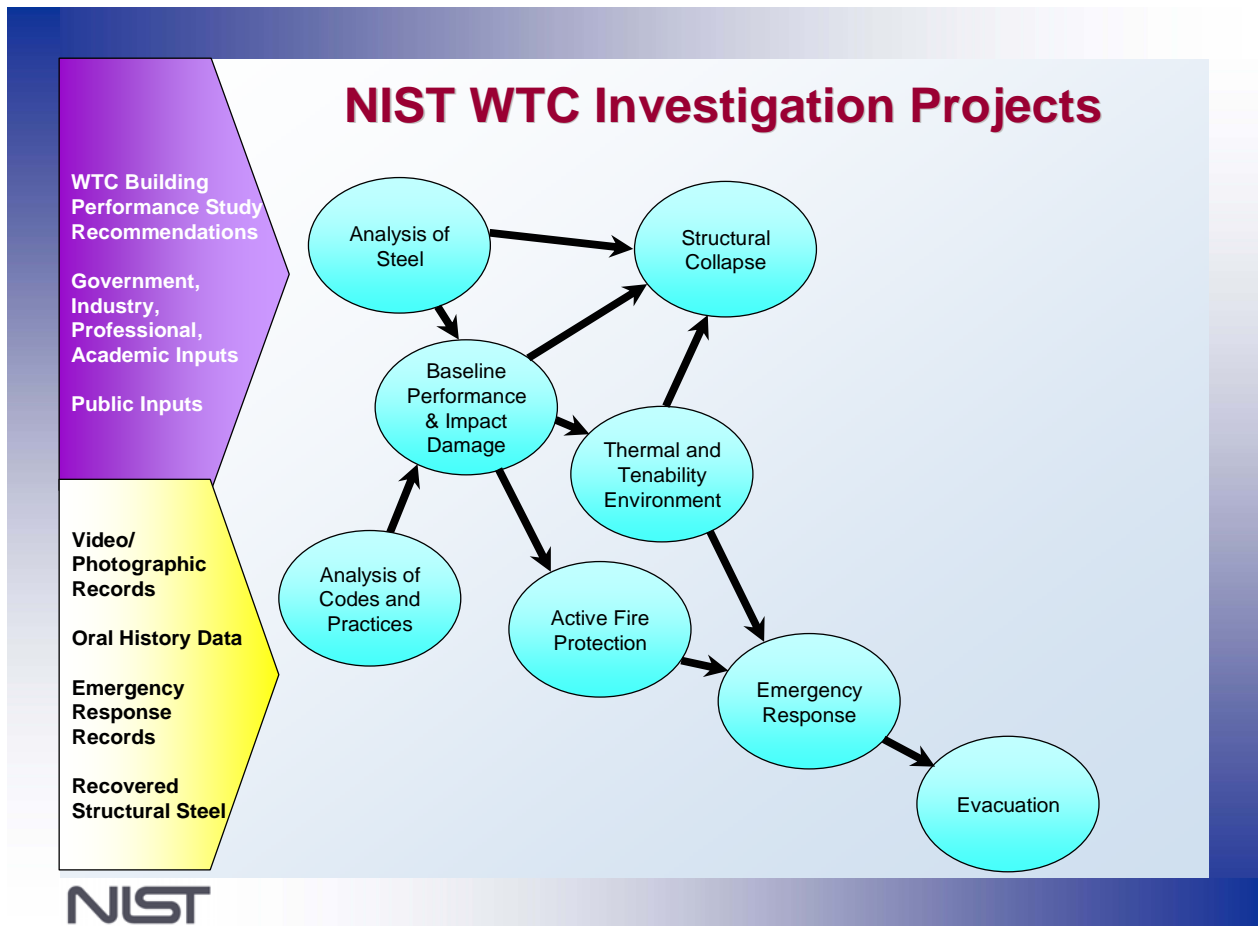

Figure P-1. The eight projects in the federal building and fire safety investigation of the WTC disaster.

National Construction Safety Team Advisory Committee

The NIST Director also established an advisory committee as mandated under the National Construction Safety Team Act. The initial members of the committee were appointed following a public solicitation. These were:

- Paul Fitzgerald, Executive Vice President (retired) FM Global, National Construction Safety Team Advisory Committee Chair
- John Barsom, President, Barsom Consulting, Ltd.
- John Bryan, Professor Emeritus, University of Maryland
- David Collins, President, The Preview Group, Inc.
- Glenn Corbett, Professor, John Jay College of Criminal Justice
- Philip DiNunno, President, Hughes Associates, Inc.

- Robert Hanson, Professor Emeritus, University of Michigan
- Charles Thornton, Co-Chairman and Managing Principal, The Thornton-Tomasetti Group, Inc.
- Kathleen Tierney, Director, Natural Hazards Research and Applications Information Center, University of Colorado at Boulder
- Forman Williams, Director, Center for Energy Research, University of California at San Diego

This National Construction Safety Team Advisory Committee provided technical advice during the Investigation and commentary on drafts of the Investigation reports prior to their public release.

Public Outreach

During the course of this Investigation, NIST held public briefings and meetings (listed in Table P-2) to solicit input from the public, present preliminary findings, and obtain comments on the direction and progress of the Investigation from the public and the Advisory Committee.

NIST maintained a publicly accessible Web site during this Investigation at <http://wtc.nist.gov>. The site contained extensive information on the background and progress of the Investigation.

NIST's WTC Public-Private Response Plan

The collapse of the WTC buildings has led to broad reexamination of how tall buildings are designed, constructed, maintained, and used, especially with regard to major events such as fires, natural disasters, and terrorist attacks. Reflecting the enhanced interest in effecting necessary change, NIST, with support from Congress and the Administration, has put in place a program, the goal of which is to develop and implement the standards, technology, and practices needed for cost-effective improvements to the safety and security of buildings and building occupants, including evacuation, emergency response procedures, and threat mitigation.

The strategy to meet this goal is a three-part NIST-led public-private response program that includes:

- A federal building and fire safety investigation to study the most probable factors that contributed to post-aircraft impact collapse of the WTC towers and the 47-story WTC 7 building, and the associated evacuation and emergency response experience.
- A research and development (R&D) program to (a) facilitate the implementation of recommendations resulting from the WTC Investigation, and (b) provide the technical basis for cost-effective improvements to national building and fire codes, standards, and practices that enhance the safety of buildings, their occupants, and emergency responders.

Table P-2. Public meetings and briefings of the WTC Investigation.

Date	Location	Principal Agenda
June 24, 2002	New York City, NY	Public meeting: Public comments on the <i>Draft Plan</i> for the pending WTC Investigation.
August 21, 2002	Gaithersburg, MD	Media briefing announcing the formal start of the Investigation.
December 9, 2002	Washington, DC	Media briefing on release of the <i>Public Update</i> and NIST request for photographs and videos.
April 8, 2003	New York City, NY	Joint public forum with Columbia University on first-person interviews.
April 29–30, 2003	Gaithersburg, MD	National Construction Safety Team (NCST) Advisory Committee meeting on plan for and progress on WTC Investigation with a public comment session.
May 7, 2003	New York City, NY	Media briefing on release of the <i>May 2003 Progress Report</i> .
August 26–27, 2003	Gaithersburg, MD	NCST Advisory Committee meeting on status of WTC investigation with a public comment session.
September 17, 2003	New York City, NY	Media briefing and public briefing on initiation of first-person data collection projects.
December 2–3, 2003	Gaithersburg, MD	NCST Advisory Committee meeting on status and initial results and the release of the <i>Public Update</i> with a public comment session.
February 12, 2004	New York City, NY	Public meeting: Briefing on progress and preliminary findings with public comments on issues to be considered in formulating final recommendations.
June 18, 2004	New York City, NY	Media briefing and public briefing on release of the <i>June 2004 Progress Report</i> .
June 22–23, 2004	Gaithersburg, MD	NCST Advisory Committee meeting on the status of and preliminary findings from the WTC Investigation with a public comment session.
August 24, 2004	Northbrook, IL	Public viewing of standard fire resistance test of WTC floor system at Underwriters Laboratories, Inc.
October 19–20, 2004	Gaithersburg, MD	NCST Advisory Committee meeting on status and near complete set of preliminary findings with a public comment session.
November 22, 2004	Gaithersburg, MD	NCST Advisory Committee discussion on draft annual report to Congress, a public comment session, and a closed session to discuss pre-draft recommendations for WTC Investigation.
April 5, 2005	New York City, NY	Media briefing and public briefing on release of the probable collapse sequence for the WTC towers and draft reports for the projects on codes and practices, evacuation, and emergency response.
June 23, 2005	New York City, NY	Media briefing and public briefing on release of all draft reports and draft recommendations for public comment.

- A dissemination and technical assistance program (DTAP) to (a) engage leaders of the construction and building community in ensuring timely adoption and widespread use of proposed changes to practices, standards, and codes resulting from the WTC Investigation and the R&D program, and (b) provide practical guidance and tools to better prepare facility owners, contractors, architects, engineers, emergency responders, and regulatory authorities to respond to future disasters.

The desired outcomes are to make buildings, occupants, and first responders safer in future disaster events.

National Construction Safety Team Reports on the WTC Investigation

A draft of the final report on the collapses of the WTC towers is being issued as NIST NCSTAR 1. A companion report on the collapse of WTC 7 is being issued as NIST NCSTAR 1A. The present report is one of a set that provides more detailed documentation of the Investigation findings and the means by which these technical results were achieved. As such, it is part of the archival record of this Investigation. The titles of the full set of Investigation publications are:

NIST (National Institute of Standards and Technology). 2005. *Federal Building and Fire Safety Investigation of the World Trade Center Disaster: Final Report of the National Construction Safety Team on the Collapses of the World Trade Center Towers*. NIST NCSTAR 1. Gaithersburg, MD, September.

NIST (National Institute of Standards and Technology). 2005. *Federal Building and Fire Safety Investigation of the World Trade Center Disaster: Final Report of the National Construction Safety Team on the Collapse of World Trade Center 7*. NIST NCSTAR 1A. Gaithersburg, MD, December.

Lew, H. S., R. W. Bukowski, and N. J. Carino. 2005. *Federal Building and Fire Safety Investigation of the World Trade Center Disaster: Design, Construction, and Maintenance of Structural and Life Safety Systems*. NIST NCSTAR 1-1. National Institute of Standards and Technology. Gaithersburg, MD, September.

Fanella, D. A., A. T. Derecho, and S. K. Ghosh. 2005. *Federal Building and Fire Safety Investigation of the World Trade Center Disaster: Design and Construction of Structural Systems*. NIST NCSTAR 1-1A. National Institute of Standards and Technology. Gaithersburg, MD, September.

Ghosh, S. K., and X. Liang. 2005. *Federal Building and Fire Safety Investigation of the World Trade Center Disaster: Comparison of Building Code Structural Requirements*. NIST NCSTAR 1-1B. National Institute of Standards and Technology. Gaithersburg, MD, September.

Fanella, D. A., A. T. Derecho, and S. K. Ghosh. 2005. *Federal Building and Fire Safety Investigation of the World Trade Center Disaster: Maintenance and Modifications to Structural Systems*. NIST NCSTAR 1-1C. National Institute of Standards and Technology. Gaithersburg, MD, September.

Grill, R. A., and D. A. Johnson. 2005. *Federal Building and Fire Safety Investigation of the World Trade Center Disaster: Fire Protection and Life Safety Provisions Applied to the Design and Construction of World Trade Center 1, 2, and 7 and Post-Construction Provisions Applied after Occupancy*. NIST NCSTAR 1-1D. National Institute of Standards and Technology. Gaithersburg, MD, September.

Razza, J. C., and R. A. Grill. 2005. *Federal Building and Fire Safety Investigation of the World Trade Center Disaster: Comparison of Codes, Standards, and Practices in Use at the Time of the Design and Construction of World Trade Center 1, 2, and 7*. NIST NCSTAR 1-1E. National Institute of Standards and Technology. Gaithersburg, MD, September.

Grill, R. A., D. A. Johnson, and D. A. Fanella. 2005. *Federal Building and Fire Safety Investigation of the World Trade Center Disaster: Comparison of the 1968 and Current (2003) New*

York City Building Code Provisions. NIST NCSTAR 1-1F. National Institute of Standards and Technology. Gaithersburg, MD, September.

Grill, R. A., and D. A. Johnson. 2005. *Federal Building and Fire Safety Investigation of the World Trade Center Disaster: Amendments to the Fire Protection and Life Safety Provisions of the New York City Building Code by Local Laws Adopted While World Trade Center 1, 2, and 7 Were in Use.* NIST NCSTAR 1-1G. National Institute of Standards and Technology. Gaithersburg, MD, September.

Grill, R. A., and D. A. Johnson. 2005. *Federal Building and Fire Safety Investigation of the World Trade Center Disaster: Post-Construction Modifications to Fire Protection and Life Safety Systems of World Trade Center 1 and 2.* NIST NCSTAR 1-1H. National Institute of Standards and Technology. Gaithersburg, MD, September.

Grill, R. A., D. A. Johnson, and D. A. Fanella. 2005. *Federal Building and Fire Safety Investigation of the World Trade Center Disaster: Post-Construction Modifications to Fire Protection, Life Safety, and Structural Systems of World Trade Center 7.* NIST NCSTAR 1-1I. National Institute of Standards and Technology. Gaithersburg, MD, September.

Grill, R. A., and D. A. Johnson. 2005. *Federal Building and Fire Safety Investigation of the World Trade Center Disaster: Design, Installation, and Operation of Fuel System for Emergency Power in World Trade Center 7.* NIST NCSTAR 1-1J. National Institute of Standards and Technology. Gaithersburg, MD, September.

Sadek, F. 2005. *Federal Building and Fire Safety Investigation of the World Trade Center Disaster: Baseline Structural Performance and Aircraft Impact Damage Analysis of the World Trade Center Towers.* NIST NCSTAR 1-2. National Institute of Standards and Technology. Gaithersburg, MD, September.

Faschan, W. J., and R. B. Garlock. 2005. *Federal Building and Fire Safety Investigation of the World Trade Center Disaster: Reference Structural Models and Baseline Performance Analysis of the World Trade Center Towers.* NIST NCSTAR 1-2A. National Institute of Standards and Technology. Gaithersburg, MD, September.

Kirkpatrick, S. W., R. T. Bocchieri, F. Sadek, R. A. MacNeill, S. Holmes, B. D. Peterson, R. W. Cilke, C. Navarro. 2005. *Federal Building and Fire Safety Investigation of the World Trade Center Disaster: Analysis of Aircraft Impacts into the World Trade Center Towers,* NIST NCSTAR 1-2B. National Institute of Standards and Technology. Gaithersburg, MD, September.

Gayle, F. W., R. J. Fields, W. E. Luecke, S. W. Banovic, T. Foecke, C. N. McCowan, T. A. Siewert, and J. D. McColskey. 2005. *Federal Building and Fire Safety Investigation of the World Trade Center Disaster: Mechanical and Metallurgical Analysis of Structural Steel.* NIST NCSTAR 1-3. National Institute of Standards and Technology. Gaithersburg, MD, September.

Luecke, W. E., T. A. Siewert, and F. W. Gayle. 2005. *Federal Building and Fire Safety Investigation of the World Trade Center Disaster: Contemporaneous Structural Steel Specifications.* NIST Special Publication 1-3A. National Institute of Standards and Technology. Gaithersburg, MD, September.

- Banovic, S. W. 2005. *Federal Building and Fire Safety Investigation of the World Trade Center Disaster: Steel Inventory and Identification*. NIST NCSTAR 1-3B. National Institute of Standards and Technology. Gaithersburg, MD, September.
- Banovic, S. W., and T. Foecke. 2005. *Federal Building and Fire Safety Investigation of the World Trade Center Disaster: Damage and Failure Modes of Structural Steel Components*. NIST NCSTAR 1-3C. National Institute of Standards and Technology. Gaithersburg, MD, September.
- Luecke, W. E., J. D. McColskey, C. N. McCowan, S. W. Banovic, R. J. Fields, T. Foecke, T. A. Siewert, and F. W. Gayle. 2005. *Federal Building and Fire Safety Investigation of the World Trade Center Disaster: Mechanical Properties of Structural Steels*. NIST NCSTAR 1-3D. National Institute of Standards and Technology. Gaithersburg, MD, September.
- Banovic, S. W., C. N. McCowan, and W. E. Luecke. 2005. *Federal Building and Fire Safety Investigation of the World Trade Center Disaster: Physical Properties of Structural Steels*. NIST NCSTAR 1 3E. National Institute of Standards and Technology. Gaithersburg, MD, September.
- Evans, D. D., E. D. Kuligowski, W. S. Dols, and W. L. Grosshandler. 2005. *Federal Building and Fire Safety Investigation of the World Trade Center Disaster: Active Fire Protection Systems*. NIST NCSTAR 1-4. National Institute of Standards and Technology. Gaithersburg, MD, September.
- Kuligowski, E. D., and D. D. Evans. 2005. *Federal Building and Fire Safety Investigation of the World Trade Center Disaster: Post-Construction Fires Prior to September 11, 2001*. NIST NCSTAR 1-4A. National Institute of Standards and Technology. Gaithersburg, MD, September.
- Hopkins, M., J. Schoenrock, and E. Budnick. 2005. *Federal Building and Fire Safety Investigation of the World Trade Center Disaster: Fire Suppression Systems*. NIST NCSTAR 1-4B. National Institute of Standards and Technology. Gaithersburg, MD, September.
- Keough, R. J., and R. A. Grill. 2005. *Federal Building and Fire Safety Investigation of the World Trade Center Disaster: Fire Alarm Systems*. NIST NCSTAR 1-4C. National Institute of Standards and Technology. Gaithersburg, MD, September.
- Ferreira, M. J., and S. M. Strege. 2005. *Federal Building and Fire Safety Investigation of the World Trade Center Disaster: Smoke Management Systems*. NIST NCSTAR 1-4D. National Institute of Standards and Technology. Gaithersburg, MD, September.
- Gann, R. G., A. Hamins, K. B. McGrattan, G. W. Mulholland, H. E. Nelson, T. J. Ohlemiller, W. M. Pitts, and K. R. Prasad. 2005. *Federal Building and Fire Safety Investigation of the World Trade Center Disaster: Reconstruction of the Fires in the World Trade Center Towers*. NIST NCSTAR 1-5. National Institute of Standards and Technology. Gaithersburg, MD, September.
- Pitts, W. M., K. M. Butler, and V. Junker. 2005. *Federal Building and Fire Safety Investigation of the World Trade Center Disaster: Visual Evidence, Damage Estimates, and Timeline Analysis*. NIST NCSTAR 1-5A. National Institute of Standards and Technology. Gaithersburg, MD, September.
- Hamins, A., A. Maranghides, K. B. McGrattan, E. Johnsson, T. J. Ohlemiller, M. Donnelly, J. Yang, G. Mulholland, K. R. Prasad, S. Kukuck, R. Anleitner and T. McAllister. 2005. *Federal*

Building and Fire Safety Investigation of the World Trade Center Disaster: Experiments and Modeling of Structural Steel Elements Exposed to Fire. NIST NCSTAR 1-5B. National Institute of Standards and Technology. Gaithersburg, MD, September.

Ohlemiller, T. J., G. W. Mulholland, A. Maranghides, J. J. Filliben, and R. G. Gann. 2005. *Federal Building and Fire Safety Investigation of the World Trade Center Disaster: Fire Tests of Single Office Workstations.* NIST NCSTAR 1-5C. National Institute of Standards and Technology. Gaithersburg, MD, September.

Gann, R. G., M. A. Riley, J. M. Repp, A. S. Whittaker, A. M. Reinhorn, and P. A. Hough. 2005. *Federal Building and Fire Safety Investigation of the World Trade Center Disaster: Reaction of Ceiling Tile Systems to Shocks.* NIST NCSTAR 1-5D. National Institute of Standards and Technology. Gaithersburg, MD, September.

Hamins, A., A. Maranghides, K. B. McGrattan, T. J. Ohlemiller, and R. Anleitner. 2005. *Federal Building and Fire Safety Investigation of the World Trade Center Disaster: Experiments and Modeling of Multiple Workstations Burning in a Compartment.* NIST NCSTAR 1-5E. National Institute of Standards and Technology. Gaithersburg, MD, September.

McGrattan, K. B., C. Bouldin, and G. Forney. 2005. *Federal Building and Fire Safety Investigation of the World Trade Center Disaster: Computer Simulation of the Fires in the World Trade Center Towers.* NIST NCSTAR 1-5F. National Institute of Standards and Technology. Gaithersburg, MD, September.

Prasad, K. R., and H. R. Baum. 2005. *Federal Building and Fire Safety Investigation of the World Trade Center Disaster: Fire Structure Interface and Thermal Response of the World Trade Center Towers.* NIST NCSTAR 1-5G. National Institute of Standards and Technology. Gaithersburg, MD, September.

Gross, J. L., and T. McAllister. 2005. *Federal Building and Fire Safety Investigation of the World Trade Center Disaster: Structural Fire Response and Probable Collapse Sequence of the World Trade Center Towers.* NIST NCSTAR 1-6. National Institute of Standards and Technology. Gaithersburg, MD, September.

Carino, N. J., M. A. Starnes, J. L. Gross, J. C. Yang, S. Kukuck, K. R. Prasad, and R. W. Bukowski. 2005. *Federal Building and Fire Safety Investigation of the World Trade Center Disaster: Passive Fire Protection.* NIST NCSTAR 1-6A. National Institute of Standards and Technology. Gaithersburg, MD, September.

Gross, J., F. Hervey, M. Izydorek, J. Mammoser, and J. Treadway. 2005. *Federal Building and Fire Safety Investigation of the World Trade Center Disaster: Fire Resistance Tests of Floor Truss Systems.* NIST NCSTAR 1-6B. National Institute of Standards and Technology. Gaithersburg, MD, September.

Zarghamee, M. S., S. Bolourchi, D. W. Eggers, F. W. Kan, Y. Kitane, A. A. Liepins, M. Mudlock, W. I. Naguib, R. P. Ojdovic, A. T. Sarawit, P. R. Barrett, J. L. Gross, and T. P. McAllister. 2005. *Federal Building and Fire Safety Investigation of the World Trade Center Disaster: Component,*

Connection, and Subsystem Structural Analysis. NIST NCSTAR 1-6C. National Institute of Standards and Technology. Gaithersburg, MD, September.

Zarghamee, M. S., Y. Kitane, O. O. Erbay, T. P. McAllister, and J. L. Gross. 2005. *Federal Building and Fire Safety Investigation of the World Trade Center Disaster: Global Structural Analysis of the Response of the World Trade Center Towers to Impact Damage and Fire.* NIST NCSTAR 1-6D. National Institute of Standards and Technology. Gaithersburg, MD, September.

McAllister, T., R. G. Gann, J. L. Gross, K. B. McGrattan, H. E. Nelson, W. M. Pitts, K. R. Prasad. 2005. *Federal Building and Fire Safety Investigation of the World Trade Center Disaster: Structural Fire Response and Probable Collapse Sequence of World Trade Center 7.* 2005. NIST NCSTAR 1-6E. National Institute of Standards and Technology. Gaithersburg, MD, December.

Gilsanz, R., V. Arbitrio, C. Anders, D. Chlebus, K. Ezzeldin, W. Guo, P. Moloney, A. Montalva, J. Oh, K. Rubenacker. 2005. *Federal Building and Fire Safety Investigation of the World Trade Center Disaster: Structural Analysis of the Response of World Trade Center 7 to Debris Damage and Fire.* NIST NCSTAR 1-6F. National Institute of Standards and Technology. Gaithersburg, MD, December.

Kim, W. 2005. *Federal Building and Fire Safety Investigation of the World Trade Center Disaster: Analysis of September 11, 2001, Seismogram Data,* NIST NCSTAR 1-6G. National Institute of Standards and Technology. Gaithersburg, MD, December.

Nelson, K. 2005. *Federal Building and Fire Safety Investigation of the World Trade Center Disaster: The ConEd Substation in World Trade Center 7,* NIST NCSTAR 1-6H. National Institute of Standards and Technology. Gaithersburg, MD, December.

Averill, J. D., D. S. Mileti, R. D. Peacock, E. D. Kuligowski, N. Groner, G. Proulx, P. A. Reneke, and H. E. Nelson. 2005. *Federal Building and Fire Safety Investigation of the World Trade Center Disaster: Occupant Behavior, Egress, and Emergency Communication.* NIST NCSTAR 1-7. National Institute of Standards and Technology. Gaithersburg, MD, September.

Fahy, R., and G. Proulx. 2005. *Federal Building and Fire Safety Investigation of the World Trade Center Disaster: Analysis of Published Accounts of the World Trade Center Evacuation.* NIST NCSTAR 1-7A. National Institute of Standards and Technology. Gaithersburg, MD, September.

Zmud, J. 2005. *Federal Building and Fire Safety Investigation of the World Trade Center Disaster: Technical Documentation for Survey Administration.* NIST NCSTAR 1-7B. National Institute of Standards and Technology. Gaithersburg, MD, September.

Lawson, J. R., and R. L. Vettori. 2005. *Federal Building and Fire Safety Investigation of the World Trade Center Disaster: The Emergency Response Operations.* NIST NCSTAR 1-8. National Institute of Standards and Technology. Gaithersburg, MD, September.

ACKNOWLEDGMENTS

This report relies heavily on the material provided in National Institute of Standards and Technology (NIST) NCSTAR 1-4A, NIST NCSTAR 1-4B, NIST NCSTAR 1-4C, and NIST NCSTAR 1-4D. In particular, the NIST team would like to acknowledge the substantial efforts of Hughes Associates, Inc. in the areas of fire suppression (M.J. Hopkins, E. Schoenrock, and E. Budnick) and smoke management systems (M.J. Ferreira and S.M. Strege), and of Rolf Jensen & Associates, Inc., in the area of fire alarm systems (R.J. Keough, R.J. and R.A. Grill). There are many instances in this document where material has been taken directly from the contractor reports cited above without the use of quotation marks.

John Drucker, who previously served as project manager for Siemens Building Technologies - the contractor implementing the upgrades to the fire alarm systems for the World Trade Center (WTC) - deserves special thanks for his assistance in providing background and detailed information on the fire alarm systems within the WTC which would not have been available otherwise. The authors also wish to acknowledge the assistance provided by Steven Hill of the Bureau of Alcohol, Tobacco and Firearms.

As it is important that all readers of this report have a common basis for understanding the results of the investigation, information is provided to orient readers to the basic functioning and intent of active fire protection systems. Chris Jelenewicz, Engineering Programs Manager, Society of Fire Protection Engineers, assisted the authors by providing easily understood introductory and summary materials.

This page intentionally left blank.

EXECUTIVE SUMMARY

In the event of a fire in a building, the safety of occupants and first responders and the protection of property is accomplished through a combination of passive and active means. A passive fire protection system is one which is an integral part of the building layout and materials of construction, such as partitions to confine the fire, a stairway to assist rapid evacuation, or spray-on fire proofing to increase the fire resistance of a load-bearing steel structure. Active fire protection systems are designed to come into play only when a fire is present and require activation through a combination of sensors or mechanical means. The active fire protection systems in World Trade Center (WTC) 1, 2, and 7 consisted of fire sensors and alarms, notification systems, sprinklers, water supplies, and smoke management systems. Active and passive fire protection systems work together to control the spread of the fire and maintain the integrity of the structure; however, the fire department is always relied upon to fully extinguish the fire and rescue occupants who may be immobilized.

The automatic fire sprinkler systems in WTC 1, 2, and 7 were the first line of defense. Water stored in the building from public sources or pumped from fire apparatus was supplied through dedicated piping to the area of the fire. Also present in the buildings were hoses, preconnected to a water supply through standpipes located in the stairwells and other utility shafts. The standpipes provided hose connections at each floor for The Fire Department of the City of New York (FDNY). In addition, standpipe preconnected hoses were installed for trained occupants to manually suppress fires.

The heart of the fire detection system was the automatic fire alarm and emergency notification system. Occupants in the building depended on this system to detect fires and provide information for emergency evacuation. Capabilities were also designed for the ventilation system to operate in a way to purge smoke produced by fires from the building. Smoke purge was intended to be used for post-fire clean-up but could be used during a fire event at the discretion of the FDNY.

This report includes an examination of the design and installation of the active fire protection systems in WTC 1, 2, and 7 and a description of the normal operation of fully functional systems and their potential effect on controlling the fires on September 11, 2001. The applicable building and fire codes and standards, as well as the history of fires in these buildings, are also documented.

E.1 SIGNIFICANT FIRES PRIOR TO SEPTEMBER 11, 2001

Significant fires in WTC 1, 2, and 7 prior to September 11, 2001, were of interest to the investigation, particularly those that activated multiple sprinklers or where hoses were used to suppress the fires. Because the records of fire events in the buildings maintained by The Port Authority of New York and New Jersey (PANYNJ) were destroyed in the fire and collapse of WTC 1, information available for study was limited to that from FDNY fire and investigation reports.

A major fire occurring in WTC 1 in 1975, prior to the installation of sprinklers, and the bombing of the WTC towers in 1993 were the most significant incidents in the history of these buildings. In addition, 47 other fires were identified that were substantial enough to activate a sprinkler or require hoses to suppress the fire. Sixteen fire incidents exercised multiple sprinklers or multiple standpipe connected

hoses (with or without the activation of at least one sprinkler). Thirty-one fires involved the use of one standpipe hose or one standpipe hose and discharge of one sprinkler. Only three fires were identified to have occurred in WTC 7 prior to 2001. The FDNY fire reports and fire investigation records obtained by the National Institute of Standards and Technology (NIST) indicate that in areas protected by automatic sprinklers, no fire activated more than three sprinklers.

E.2 SPRINKLERS, STANDPIPES, AND PRECONNECTED HOSE SYSTEMS

The evaluation of the sprinklers, standpipes, and preconnected hose systems was performed by subject experts at Hughes Associates, Inc., under contract to NIST. The project documented the design, installation, and operation of the fire suppression systems in WTC 1, 2, and 7; evaluated the consistency of the sprinkler and standpipe systems installations with best engineering practices; described the New York City (NYC) water supply system and evaluated the sprinkler system water supply; and estimated suppression system performance when challenged with design fire scenarios assumed in standard engineering practice as well as with a fire scenario similar to that which occurred on September 11, 2001.

Major features of the fire suppression systems are documented based on a review of the available information. In addition to describing in detail the sprinkler, standpipe, and preconnected hose systems, special fire suppression systems are briefly discussed. System features documented include riser systems, zone arrangements, water tanks, pumps, fire department connections, control valves, and hose rack arrangements. Additionally, documentation of the sprinkler, standpipe, and preconnected hose system installations was examined for consistency with the applicable installation standards and state-of-the-art engineering practices at the time of system installation.

A description of the NYC water supply, including sizes, locations, and directions of water mains surrounding the WTC complex and distribution system within the buildings is provided to adequately evaluate the primary source of water for the automatic sprinkler and hose systems. Adequacy of the sprinkler system water supply was based on a detailed review of the available documentation. Flow capacity and duration of water supplies to the installed sprinkler systems were estimated using industry-accepted software. Hydraulic calculations were performed with variations in primary and secondary water supplies, the number of sprinklers flowing, and floor level elevations. The results from the calculations were used to evaluate the expected sprinkler system performance.

Multiple fire scenarios were analyzed in order to more fully understand the potential impact of the suppression systems to provide the flow of water required to control typical office fires within high-rise buildings. The analysis included single fires on different floors in the towers and in WTC 7 with various combinations of sprinklers activated and with primary and secondary water supplies. Additionally, hydraulic calculations based on simultaneous fires on up to a total of nine floors were performed. Estimates of suppression system performance in WTC 1, 2, and 7 on September 11, 2001, were also made.

The following list summarizes the findings of the suppression and water supply study:

- Except for specific areas that were exempted from required sprinkler coverage, sprinklers were installed throughout WTC 1, 2, and 7 on September 11, 2001.

- According to the documentation examined, the fire suppression systems in WTC 1, 2, and 7 were installed, for the most part, in a manner consistent with state-of-the-art practices in existence at the time of their installation. The installations as documented, with several minor exceptions, would satisfy current best practices.
- Storage tanks, along with direct connections to the NYC water distribution system, supplied water for WTC 1 and WTC 2, and for floors 21 through 47 of WTC 7. Fire suppression systems for floors 1 through 20 in WTC 7 were supplied directly through the NYC water distribution system and an automatic fire pump, with no secondary supply.
- The installation of the supply piping from the storage tanks on the 110th floor in WTC 1 and WTC 2 resulted in restricted flow capacity to several floors. The flow capacity was sufficient to supply the suppression systems, but the installation was not consistent with current engineering best practices.
- The suppression systems in WTC 1, 2, and 7 required manual initiation of the electrical fire pumps in order to provide supplemental water. An automatic supplemental water supply has been required by National Fire Protection Association (NFPA) 14 for some time and represents best practice. Due to extensive damage to the sprinkler and standpipe systems in WTC 1 and WTC 2 on September 11, 2001, it is doubtful that automatic pumps would have made any difference in performance.
- The supply risers for automatic sprinkler systems in WTC 1, 2, and 7 were configured to provide redundant capabilities. However, the sprinkler floor level controls were installed with one connection to the sprinkler water riser. This represented a single point of failure location for the water supply to the sprinklers on that floor.
- The water flow capacities of the sprinkler systems installed in WTC 1, 2, and 7 were designed to provide densities considerably greater than typically provided for high-rise office buildings. Based on hydraulic calculations, it was estimated that the sprinkler systems could have controlled a typical fire at a coverage area up to two to three times the specific design area of 1,500 ft². However, a coverage area of 4,500 ft² constitutes less than 15 percent of the area of a single floor.
- The standpipe and preconnected hose systems were consistent with the applicable requirements in the Building Code of New York City (BCNYC). They were not consistent with the flow rates and durations specified by NFPA 13.
- The loading berth and fuel oil pump rooms in WTC 7 were protected by dry-pipe sprinkler systems. The first floor room containing the 6,000 gal fuel oil tank was protected by an Inergen clean agent fire suppression system.
- The fifth floor generator room was not equipped with a sprinkler system, consistent with the BCNYC. No information was found that indicated that the generator/fuel day-tank enclosures elsewhere in WTC 7 were protected by a fire suppression system.

- Primary and backup power were provided in all three buildings, but the absence of remote redundancy of the power lines to emergency fire pumps could have affected the operability of the sprinkler and standpipe systems once power was lost.
- Due to the magnitude of the initial fires and the likely aircraft impact-induced damage sustained to the suppression systems infrastructures in WTC 1 and WTC 2, it is not unexpected that the suppression systems present in these buildings failed to control the fires on September 11, 2001.

E.3 FIRE ALARM SYSTEMS

The evaluation of the fire alarm systems, a review of applicable codes and standards, documentation of the normal operation of fully functional fire alarm systems, and their potential performance in WTC 1, 2, and 7 on September 11, 2001, were performed by subject experts at Rolf Jensen and Associates, Inc., under contract to NIST.

Major features of the fire alarm systems in WTC 1, 2, and 7 are described based on a review of the available documentation. Details on the fire command station, fire alarm system functions, fire alarm system installation criteria, control panel configurations, fire alarm devices, and firefighter telephone system are provided. Additionally, the staff emergency response plan that provided direction for emergency response is outlined. The responsibilities of the fire safety director, deputy fire directors, assistant fire safety coordinator, and floor wardens are described.

For WTC 1 and WTC 2, performance on September 11, 2001, was documented based on brief images of illuminated status lamps on the system's control panels, which were filmed during the event, and through interviews with people who were in the buildings at the time. The performance of the WTC 7 fire alarm system was assessed on the basis of the printout of the fire alarm system's remote monitoring system.

The following is a summary of findings based upon the review of the building designs and analysis of the various fire alarm systems:

- Because the WTC 1 and WTC 2 fire alarm system required manual activation to notify building occupants, the alarm signal was delayed until 12 min after impact in WTC 1.
- The telephone circuits and the notification appliance circuits were not required to have the same performance requirements as the signaling line circuits.
- Attempts were made to use the firefighter telephone systems in WTC 1 and WTC 2 on September 11, 2001; however the system was not functioning.
- Although the fire alarm systems in WTC 1 and WTC 2 used multiple communication path risers, the systems experienced performance degradation, especially in WTC 1 where all fire alarm notification and communication functions appear to have been lost above the floors of impact.

- The fire alarm system installed in WTC 7 sent to the monitoring company only one signal indicating a fire condition in the building on September 11, 2001. This signal did not contain any specific information about the location of the fire within the building.

E.4 SMOKE MANAGEMENT

Subject experts at Hughes Associates, Inc., under contract to NIST, evaluated the design and installation of the smoke management systems in WTC 1, 2, and 7, reviewed applicable codes and standards, and documented the normal operation of the fully functional smoke management systems and their potential effect on smoke conditions in WTC 1 and WTC 2 on September 11, 2001.

The review of building codes and standards determined those that were applicable to WTC 1, 2, and 7. Specifically, the versions of BCNYC that applied and the local laws that were enacted which pertain to smoke management are presented. This review was used as a basis for documenting building designs and evaluating system performance. Descriptions are provided of the basic architecture of each building as it pertains to the establishment of smoke control zones, heating, ventilation and air-conditioning (HVAC) components and layout relevant to smoke management, and sequences of operation of smoke management systems (i.e., activation of fans and positioning of dampers to control airflow during smoke control operations).

Smoke management system performance of WTC 1 and WTC 2 was evaluated based on the understanding of the systems developed during the design reviews. Analysis was performed using industry-accepted software to analyze the interaction between the building and the HVAC systems to determine the extent to which building pressures could be maintained in order to control or prevent the spread of smoke from a zone of fire origin to the rest of the building. The ability of the documented smoke management system to perform under typical design fire scenarios was analyzed along with the ability of the – assumed to be fully functional – system to perform given the damage sustained and the extreme fire/smoke conditions that developed as a result of aircraft impacts on the building.

In order to more fully understand the potential impact of smoke management systems within high-rise buildings, multiple smoke management strategies, design fire scenarios, building configurations and weather conditions were analyzed. In total, a set of 180 simulations were performed, and results were evaluated.

The following are findings from the evaluation of the smoke management systems:

- The smoke management systems in WTC 1 and WTC 2 were not initiated on September 11, 2001.
- Had the smoke purge sequence been initiated in WTC 1 or WTC 2, it is unlikely the system would have functioned as designed, due to damage caused by aircraft impacts.
- WTC 1 and WTC 2 were not required by the 1968 BCNYC, as amended by Local Law 5 and Local Law 86, to have active smoke and heat venting and/or stair pressurization because they contained automatic sprinklers throughout.

- Even if fully operational, none of the potential smoke management systems evaluated would have prevented smoke spread given the damage caused by aircraft impact.
- During the events occurring on September 11, 2001, stair pressurization would have been ineffective in improving conditions for occupants trying to exit the building.
- Installation of combination fire/smoke dampers in HVAC ductwork, which was not required in WTC 1 or WTC 2, may have acted to slow the development of hazardous conditions on the uppermost floors of the building, but would likely not have had a significant effect on the ability of occupants to egress the building due to the impassibility of the exit stairways.

Chapter 1

OBJECTIVES AND APPROACH

1.1 OBJECTIVES

In the event of a fire in a building, the safety of occupants and first responders and the protection of property is accomplished through a combination of passive and active means. A passive fire protection system is one which is an integral part of the building layout and materials of construction, such as partitions to confine the fire, a stairway to assist rapid evacuation, or spray-on fire proofing to increase the fire resistance of a load-bearing steel structure. Active fire protection systems are designed to come into play only when a fire is present and require activation through a combination of sensors or mechanical means. The active fire protection systems in World Trade Center (WTC) buildings 1, 2, and 7 consisted of fire sensors and alarms, notification systems, sprinklers, water supplies, and smoke management systems. Active and passive fire protection systems work together to control the spread of the fire and maintain the integrity of the structure; however, the fire department is always relied upon to fully extinguish the fire and rescue occupants who may be immobilized.

The active fire protection systems studied in this investigation are the automatic fire sprinklers, preconnected hoses, fire detection and alarms, and smoke purging. The automatic fire sprinkler system was the first line of defense against fires in the WTC buildings. Automatic sprinklers are designed to provide water on and around the area of the fire to control the fire and possibly extinguish it. Water for automatic sprinklers and standpipes stored in the buildings, from public sources, and even pumped from fire apparatus could be supplied through dedicated piping to the area of the fire. Also present in the buildings were hoses preconnected to a water supply through vertical standpipes located in the stairwells and other utility shafts. The standpipes provided hose connections at each floor for The Fire Department of the City of New York (FDNY). In addition, standpipe preconnected hoses were installed for trained occupants to manually suppress fires. The heart of the fire detection system is the automatic fire alarm and emergency notification system. Occupants in the building depended on this system to detect fires and provide information for emergency evacuation. The FDNY used this system to help determine the locations of fires that could not be located visually. Capabilities were also designed for the ventilation system to purge smoke produced by fires from the buildings. Smoke purge was intended to be used for post-fire clean-up but could be used during a fire event at the discretion of the FDNY.

The active fire protection systems installed in WTC 1, 2, and 7 had the potential to reduce the severity of the fires, to provide information for occupants and first responders, and to limit the effects of the fires on the buildings and their occupants. It was the objective of this project to document the major features of the installed systems in WTC 1, 2, and 7, to evaluate their performance on September 11, 2001, and to assess their role in fire control, emergency response, and the fate of occupants and responders.

1.2 APPROACH

Many relevant documents describing the design, operation, and maintenance of the active fire protection systems for WTC 1, 2, and 7 were lost in the collapse of those buildings. With the cooperation of The

Port Authority of New York and New Jersey (PANYNJ) and Silverstein Properties Inc., information was obtained from other locations and from contractors, consultants, and operators. As an example, some information was obtained from the engineering offices of PANYNJ in Newark. Other written materials describing the design and operation of active fire protection systems were obtained from files maintained by contractors. Lastly, information from engineers and system operators was helpful in clarifying details of the installation and operation.

National Institute of Standards and Technology (NIST) investigators led three groups of fire protection systems experts. Each group specialized in one of the fire protection systems being investigated—fire sprinkler, fire alarm, and smoke management. Guidance was given to the technical experts to document systems at a level that provided a clear understanding of the design, capabilities, and normal operations. Following this guideline, all the major components of the active fire protection systems were documented, but not every part of the system hardware was addressed in detail. Information in this project report depended heavily on the technical work provided by three technical expert reports (NIST NCSTAR 1-4B, NIST NCSTAR 1-4C, NIST NCSTAR 1-4D¹). Liberal use of text and graphics from those reports has been made in assembling this project report.

Technical assistance to NIST in the investigation of the sprinklers, standpipes, and preconnected hoses was provided by Hughes Associates Inc. (HAI) of Baltimore, Maryland. This group was tasked with:

- Documenting the design and installation of the systems;
- Documenting the design and capacity of the water supply including provisions for redundancy;
- Identifying differences in the designs used in WTC 1, 2, and 7;
- Documenting the normal operation and effect of the fully functional systems for fire control;
- Assessing the probable performance of the systems in WTC 1 and WTC 2 on September 11, 2001; and
- Assessing the documented system installation procedures with respect to present best practices.

Technical assistance to NIST in the investigation of the fire alarm systems was provided by The Rolf Jensen and Associates, Inc., (RJA) of Fairfax, Virginia. This group was tasked with:

- Documenting the design and installation of the system;
- Documenting the normal operation and effect of the fully functional systems, including provisions for redundancy;
- Documenting modifications made to the fire alarm systems in WTC 1 and WTC 2 after the 1993 bombing;

¹ This reference is to one of the companion documents from this Investigation. A list of these documents appears in the Preface to this report.

- Assessing the probable performance of the systems in WTC 1 and WTC 2 on September 11, 2001; and
- Assessing the installed systems with respect to present best practices.

Technical assistance to NIST in the investigation of the smoke management systems was provided by Hughes Associates, Inc. (HAI), of Baltimore, Maryland. This group was tasked with:

- Documenting the design and installation of the systems;
- Describing the normal operation in fire emergencies; and
- Assessing the installed systems with respect to present best practices.

1.3 REPORT ORGANIZATION

A review of past fire incidents in WTC 1, 2, and 7 is included in Chapter 2. This provides perspective on the types of fires that may have been anticipated prior to September 11, 2001, and highlights the extraordinary severity of the fire and damage by which the fire protection systems (passive and active) were challenged that day. A full report on the fire history of these buildings is provided in NIST NCSTAR 1-4A.

Chapter 3, based upon the HAI contractor's report (NIST NCSTAR 1-4B), is a description and analysis of the sprinklers, hoses, and standpipe systems in WTC 1, 2, and 7. The analysis includes a thorough assessment of the flow of water that an undamaged system would have delivered to sprinklers on various floors throughout each of the buildings, assuming the designed primary and/or secondary water supplies were intact.

The fire alarm and installed emergency communications systems are described in Chapter 4. NIST NCSTAR 1-4C, written by Rolf Jensen & Associates, Inc., is the primary source for this material.

Chapter 5 is a description and an analysis of the smoke management system. In addition to reviewing the building and fire codes which address smoke management systems, describing the systems, and assessing their likely performance on September 11, 2001, a number of alternative strategies for management of the smoke are presented. A detailed report on the smoke management system is available in the contract report from HAI (NIST NCSTAR 1-4D).

The findings of the WTC Investigation in all areas pertaining to active fire protection are summarized in Chapter 6. These findings provide the basis for the recommendations for improving model standards, codes, and practices regarding the design, installation, and operation of sprinkler, fire alarm, and smoke management systems in all high rise (and selected other) buildings. Refer to NIST NCSTAR 1, for these recommendations.

This page intentionally left blank.

Chapter 2

SIGNIFICANT FIRES IN WTC 1, 2, AND 7 PRIOR TO SEPTEMBER 11, 2001

Significant fires in World Trade Center (WTC) 1, 2, and 7 prior to September 11, 2001, were of interest to understand, in particular, how the fires were suppressed. Information was sought on all fires that activated multiple sprinklers or where hoses were used to suppress the fires. Because the records of fire events in the buildings maintained by The Port Authority of New York and New Jersey (PANYNJ or Port Authority) were destroyed in the fire and collapse of WTC 1, information available for study was limited to that from The Fire Department of the City of New York (FDNY) fire and investigation reports.

2.1 FDNY RECORDS

Fires occurred in WTC 1, 2, and 7 prior to September 11, 2001. Facts related to the performance of automatic sprinkler, manual suppression, fire detection, and smoke purge systems during significant fires in the buildings after first occupancy were documented.

Extensive records of fire incidents kept in the WTC 1 offices of the PANYNJ were lost in the collapse of the building; however, FDNY maintained records of the responses to all fires. These records consisted of standardized forms on which fire events were described using codes from a predefined list of descriptive phrases and categories. In addition, some records contained supplemental information in the form of written comments about the incident.

The FDNY provided 397 Bureau of Operations Fire Reports and 112 Bureau of Fire Investigation Records (Fire Marshals' Reports) that served as the basis for this summary of the fire history in the WTC 1, 2, and 7. The National Institute of Standards and Technology (NIST) reviewed these reports of fires for the period from 1970 to 2001, and fire investigation records between 1977 and 2001, for WTC 1, 2, and 7.

2.2 SIGNIFICANT FIRES

All of the FDNY Bureau of Operations and Bureau of Fire Investigation records consisted of standardized forms that could be supplemented with other materials. Many were for minor fire events, such as fires that were extinguished by occupants before FDNY arrival. These were not of interest for this investigation. The records of significant fires were identified. NIST defined significant fire incidents as those involving the discharge of multiple sprinklers, use of a standpipe connected hose, or the combination of a single sprinkler discharge and a hose. The majority of fire records for significant fires documented the performance of the fire alarm system detectors and sprinkler systems, but almost all reports lacked information about the performance of the smoke management system.

Table 2-1 contains the categorization of all structural fire incidents contained in the FDNY records for WTC 1, 2, and 7 available to this Investigation. This information was obtained from 345 of the 397 Bureau of Operations Fire Reports that described structural fire incidents. The table contains

Table 2–1. Summary of historical fires in WTC 1, 2, and 7.

Category	Dates	Number	Generalization of Incidents
WTC 1			
No detection, no sprinkler	1980–2001	66	Unattended food/appliances, overheated elevator equipment, discarded material, welding operations, electrical failure and suspicious fires
No detection information and no sprinklers	1970–1979	79	Trash can fires, discarded material, food on stove, electrical failure, overheated equipment
Detection, no sprinklers	1980–2000	57	Unattended food/appliances, overheated elevator equipment, discarded material, welding operations, electrical failure
Detection and sprinklers	1977–1999	18	Suspicious, electrical failure, discarded material
WTC 2			
No detection, no sprinkler	1980–1999	37	Discarded material, welding too close, overheated equipment, suspicious, elevator motor
No detection information and no sprinklers	1975–1979	40	Discarded material, fire in office furniture, trash can fires
Detection, no sprinklers	1981–1999	40	Food on stove, small elevator fire, electrical failure, suspicious, overheated equipment
Detection and sprinklers	1977–2000	5	Mechanical failure, suspicious
WTC 7			
No detection, no sprinkler	2000	1	Trash can fire/discarded material
Detection, no sprinklers	1990	1	Electrical switch on floor — explosion
Detection and sprinklers	1988	1	Suspicious

information on the category of fire incident, the time period over which the fire occurred, the number of records in that category, and a descriptive statement about the category. As Table 2–1 shows, the majority of the 345 Fire Reports refer to fires in WTC 1 and WTC 2, whereas only three reports provided to NIST pertained to WTC 7. The details of these incidents are documented further in NIST NCSTAR 1-4A, which contains copies of the FDNY reports used in the investigation, as well as other information that was not used by the investigation.

To summarize, 16 significant fires occurred in WTC 1, 2, and 7 that exercised multiple sprinklers or multiple standpipe connected hoses, with 12 occurring in WTC 1, three in WTC 2, and one in WTC 7. After reviewing these fires, trends developed relating to the time of day that the fires occurred. Overall, 12 of the 16 fires occurred between the hours of 6 p.m. and 4 a.m. The fires that occurred during office hours (between 7 a.m. and 6 p.m.) included a dumpster fire in the floor 43 elevator lobby (WTC 1), a dumpster fire on floor 106 (WTC 1), a kitchen fire on floor 107 (WTC 2), and a bearing overheating in the fan motor room on floor 108 (WTC 2). Almost all of the incendiary (arson) and suspicious fires (5 out of 6 fires) and unclassified or unlisted fires (4 out of 5 fires) occurred after business hours (before 7 a.m. or after 6 p.m.).

Trends in the cause of the fire, the materials involved in the fire, and the reported damage to the building also can be highlighted. Of the 16 fires and their causes, five were labeled as unlisted or unclassified, six as suspicious or incendiary, two as discarded material, and three as an electrical failure or mechanical failure. For the material involved in the fire, eight reports noted trash, waste, and supplies; two reported not listed or not classified; one reported furniture; three reported electrical equipment; one reported duct work; and one reported shanties were the material involved in the fire. Lastly, the majority of the fires were confined to the area of origin, with only two fires extending to less than 15 percent of the space on the floor.

In addition to the fires discussed above, 31 fires occurred in WTC 1 and WTC 2 that involved the use of one standpipe (with or without the activation of one sprinkler). Of these additional 31 fires, 23 occurred in WTC 1 and eight occurred in WTC 2. Four of the 31 reports describe fires that were extinguished with one sprinkler and one standpipe line. Three of these fires occurred in WTC 1 between 1986 and 1991 and the other in WTC 2 in 1981. In some of the fire reports, the FDNY noted that the sprinkler controlled the fire, and the standpipe was used to actually extinguish the remaining fire. Half of the fires were labeled as incendiary/suspicious, one was an electrical failure, and the last was unknown.

Twenty-seven of the 31 fire reports describe fires that were extinguished using one standpipe line. Twenty of these fires occurred in WTC 1, and the other seven occurred in WTC 2. A majority of these fires (19) are labeled as incendiary/suspicious or unknown, while the other causes of the fires are attributed to short circuits, abandoned material/cigarette, welding close to combustibles, and a mechanical failure. The dates of occurrence for these fires range from 1973–1999, with a majority (23) occurring between 1973 and 1985. These fire incidents did not result in any casualties, but five civilians and one uniformed officer were injured.

Two of the 27 fires involved a 300-person (April 19, 1980) and a 1,500-person (April 17, 1981) evacuation. On April 19, 1980, at 2:06 p.m., the FDNY received reports of an activated smoke detector in the return air duct on floor 106 of WTC 1. The FDNY also received reports of heavy smoke on floor 106, light smoke on floor 109, and heavy odor of smoke in stairways A and B. The report notes that while only one standpipe was used, approximately 300 people were evacuated from the Windows on the World restaurant on floor 107 via stairway C (which was clear of smoke). The fire cause was labeled as abandoned or discarded material and involved plastic material. This fire did not cause any injuries or casualties.

On April 17, 1981, at 9:18 a.m., the FDNY was informed of a fire on floor 7 and a smoke condition on floors 7 through 11 of WTC 1. The FDNY hooked up one standpipe and extinguished the fire located in an air conditioning unit in the mechanical equipment room (MER) room on floor 7. The cause of this fire was labeled as a mechanical failure. The fire report notes that the Port Authority personnel reported an evacuation of approximately 1,500 people from floors 9 through 23. However, no injuries or casualties were reported from this fire.

Two other very major incidents occurred in the WTC towers: an office fire in WTC 1 in 1975 (prior to the installation of sprinklers) and the 1993 bombing incident, which impacted both towers. On February 14, 1975, a fire started on floor 11 of WTC 1. Workers reported the fire to WTC police headquarters. When police reached the fire floor, they reported a serious fire and ordered the heating, ventilating, and air conditioning (HVAC) system be placed into the smoke purge mode. Fire spread through unprotected floor openings in utility closets. Fire damage occurred on floor 10 through floor 19.

Approximately 9,000 ft² (800 m²) of the floor 11 contents were destroyed or damaged. At that time, sprinklers had not been installed in the office spaces. However, fire barriers divided the floor into quadrants. The fire on floor 11 was confined to the southeast quadrant. Fire damage on other floors was confined to the utility closets. The fire was extinguished by the FDNY. More details about this fire incident can be found in Powers (1975) and Lathrop (1975).

The bombing incident occurred at 12:18 p.m. on February 26, 1993. The explosion occurred on the B2 level in the area of the garage under WTC 3 and adjacent to WTC 1. The explosion resulted in a loss of normal electric power in WTC 1 and WTC 2. HVAC systems shut down. Smoke spread throughout WTC 1 and to a lesser extent in WTC 2. More details about this fire can be found in Isner and Klein (1993a, 1993b).

In conclusion, many of the fires that occurred in WTC 1, 2, and 7 were recorded as suspicious or unknown in cause, occurred during off-peak work hours, and involved materials such as trash or paper-based supplies. In cases where sprinklers were activated, the FDNY records indicated that the sprinklers either extinguished the fire completely or aided in controlling the spread.

The FDNY fire reports and fire investigation records indicate that in areas protected by automatic sprinklers, no fire activated more than three sprinklers. The maximum design area for three sprinklers is a floor area of 63 m² (675 ft²) in a light hazard occupancy system of the type installed in the WTC 1, 2, and 7 office spaces and other high-rise office building as specified in the NFPA 13 Standard for the Installation of Sprinkler Systems (NFPA 13 2004). Sprinklers contained fires to a very small fraction of the area of a single floor.

Chapter 3

SPRINKLERS, STANDPIPES, AND PRECONNECTED HOSE SYSTEMS

In the event of fire in World Trade Center (WTC) 1, 2, and 7, there were two primary means to provide water for fire fighting. One was the installed fire sprinkler system. This system of water-charged piping throughout the building provided water spray from sprinklers that were installed in ceilings. In the event of a fire, hot gases would heat the sprinklers in the area of the fire. When the temperature and duration of heating was sufficient, the sprinklers that had reached a predetermined response temperature would activate and release a spray of water. Sprinkler systems were designed to control the spread and growth of expected fires. Manual intervention by fire fighters or others with hand held fire extinguishers or hose lines generally would be required to extinguish all of the burning, especially in areas that were shielded from the sprinkler spray. In some cases, fires may have been extinguished by the automatic fire sprinkler system before the fire department arrived.

In high-rise and other buildings, a network of vertical and horizontal pipes known as the standpipe systems supply water for fire hoses on each floor. On each floor there are connections provided for fire hoses carried into the building by fire fighters. The standpipes may have pre-connected hoses that can be used by building occupants. The safe and effective use of standpipe pre-connected hoses requires training.

The design of the water supply system and sizing of components that would automatically supply water to installed sprinklers and standpipe systems was guided by local building code requirements, widely used and accepted installation standards, and fire protection engineering practice. These systems provided the means for the fire department to supplement the building water supply with water pumped from street fire hydrants and other sources.

The design and installation of the fire sprinkler, standpipe, and preconnected hose systems have been documented in NIST NCSTAR 1-4B prepared for National Institute of Standards and Technology (NIST) by subject experts at Hughes Associates, Inc. This publication also includes the results from a hydraulic analysis of the systems to determine capabilities for fire suppression water flow throughout the above grade areas of WTC 1, 2, and 7. The reader is referred to Bryan (1990), Cote (2003), National Fire Protection Association (NFPA) 13 (NFPA 2002) and NFPA 14 (NFPA 2000) for comprehensive descriptions and details relied upon by engineers and contractors in the design, installation, commissioning and periodic testing of these systems.

3.1 AUTOMATIC FIRE SPRINKLER SYSTEMS

Automatic fire sprinkler technology is a 19th century invention. Modern systems have evolved over time, and are fundamentally straightforward in their operation. A major innovation in fire sprinkler technology occurred with the introduction of the spray sprinkler in the early 1950s. The spray sprinkler was designed to provide a relatively uniform distribution of the water spray to the area to be protected. This was a significant advancement over previously used sprinkler devices that produced non-uniform sprays that resulted in inefficient use of the water and gaps in the coverage.

In simple terms, an automatic fire sprinkler system consists of a water supply, a series of distribution pipes, and individual sprinkler devices. The basic systems are supported by control valves, pumps, and water flow alarms. The valves and pumps are used to maintain the water demand, both before and during a fire incident. A typical individual sprinkler installed near the ceiling is shown in Fig. 3–1.



Source: NIST.

Figure 3–1. Typical sprinkler installed in ceiling.

While there are variations, the basic operating principle involves operation of each sprinkler device, individually, when exposed to a rising temperature condition (i.e., due to the thermal output from a fire). Typically, if a fire becomes large enough, a sprinkler device in the vicinity of the fire will operate, discharging water at a rate determined by the system design. If the fire continues to grow, additional sprinklers operate. This continues until the fire is controlled or extinguished, or until the available water supply is depleted. Only those sprinklers directly exposed to the hot fire gases operate and discharge water.

The design method used for the sprinkler systems in the WTC buildings is referred to in NFPA 13, Standard for Installation of Sprinklers Systems, as the occupancy hazard fire control approach (NFPA 2004). The general premise in the design of these types of sprinkler systems is to define a hazard imposed by the occupancy use of the area served and to design the sprinkler system to limit the fire to the room or area of origin. Based on the specified occupancy hazard(s), a minimum water spray density and a minimum area of sprinkler operation must be determined.

Designs using this type of approach have been around for decades. This approach has been developed based on many years of fire testing and associated analyses. In order to employ this approach, the occupancy hazard(s) for the particular structure must be determined. There are several occupancy classifications, including the following:

- Light Hazard (including offices, data processing facilities, clubs and restaurant seating areas, commercial shops),
- Ordinary Hazard Group 1 (including manufacturing and processing plants, laundries, and restaurant service areas),

- Ordinary Hazard Group 2 (including dry cleaners, library stack areas, post office, and repair garages),
- Extra Hazard Group 1 (including metal extruding and plywood and particleboard manufacturing plants containing little or no flammable and combustible liquids),
- Extra Hazard Group 2 (flammable liquid spray booths, open oil quenching areas containing moderate to substantial amounts of flammable or combustible liquids or having areas where combustibles were shielded from the sprinkler spray).

Predominantly, WTC 1, 2, and 7 contained office spaces that were classified as Light Hazard occupancy. In an area classified as such, the quantity and combustibility of contents is assumed to be low. Fires are expected to burn with low rates of heat release. This definition requires an understanding of burning rates and combustibility and knowledge of fuel loading; examples are provided in the appendix section of NFPA 13 (NFPA 13 2004).

NFPA 13 also specifies the minimum discharge density and minimum area of coverage for the different occupancy classification sprinkler systems. The application or discharge density refers to a water flow rate over a unit area. In practice, densities are described in units of gallons per minute per square foot (gpm/ft²). Design areas are described in units of square feet. The density is used to specify the minimum flow rate to be discharged from an individual sprinkler, the design area, and the minimum flow rate required for the system. For Light Hazard occupancy sprinkler systems, NFPA 13 minimums are 0.1 gpm/ft² density and 1,500 ft² design area. This design area represented a small fraction of the area of a single floor in WTC 1, 2, and 7.

3.2 STANDPIPES AND PRECONNECTED HOSES

Standpipe systems are fixed piping systems that provide water to designated areas of a building to support manual fire fighting efforts. Typically, standpipe systems for high-rise buildings consist of vertical pipe risers with fire hose connections at each floor. The systems are supported by control valves and pumps, and have fire department connections (FDC) at the street. These FDCs are used by firefighters to supplement the building system water supply. The connections may or may not include preconnected hoses, depending on the type of system and the requirements of the local code authority. The number of standpipe risers and connections are dependent on the building configuration, size, and number of exit stairway enclosures. Usually, the systems are pressure or flow monitored to ensure operability.

The basic concept of standpipe systems has not changed appreciably over the last 90 years, although specific requirements have been modified from time to time. The nationally recognized design and installation standard for standpipe systems is NFPA 14, Standard for the Installation of Standpipe and Hose Systems (NFPA 14 2004), which was originally adopted in 1915 (Bryan 1990). While the Building Code of New York City (BCNYC) does not reference NFPA 14 specifically, the recognized types and classifications of standpipe systems, as well as associated requirements in the BCNYC, are similar to those in NFPA 14.

Typically, standpipe systems are installed to support fire department operations, use by building occupants, or both. In NFPA 14, standpipe systems are classified, accordingly, as Class I, Class II or Class III systems. The following is a brief description of each class:

- Class I Systems are designed to provide 2½ in. hose (standpipe) valves, which are used to provide heavy streams for fire department personnel usage in advanced stages of fire. Hose valves are required in all exit stair enclosures and throughout all portions of a story or building section, such that all portions of the building are within 30 ft of a nozzle at the end of a 100 ft hose.
- Class II Systems are designed to provide 1½ in. preconnected hose stations, which are used to provide small streams for trained building occupants or fire brigades to fight incipient fires and for mop up efforts. Hoses and nozzles are provided at the hose stations and are spaced similarly to Class I hose valves, except hose stations are required at all areas within 20 ft of a nozzle at the end of a 100 ft hose.
- Class III Systems are a combination of Class I and II systems; Class III systems are the same as Class I systems with added 1½ in. outlets or 1½ in. adapters and hose. Class III systems are designed for use by the fire department, trained building occupants, or a fire brigade.

The standpipe systems in WTC 1, 2, and 7 were similar to Class III systems, but were designed and installed according to the provisions of the 1968 BCNYC.

The basis of design for Class I and III standpipe systems specify a performance requirement of 500 gpm at 100 psi to be supplied to the most hydraulically remote standpipe hose connection valve and 250 gpm at 100 psi to be supplied to each additional standpipe up to a maximum of 1,250 gpm. This performance requirement anticipates the use of two 2½ in. hose lines connected to the most hydraulic-remote standpipe and an additional hose line connected to each of the other standpipes. Hydraulic-remote does not refer to physical or spatial remoteness. The most hydraulically remote standpipe is the standpipe that requires the highest initial pressure to provide the specified flow and pressure to the end standpipe hose connection valve. The design of Class II standpipe systems includes 100 gpm for the most hydraulically demanding standpipe at 65 psi.

Performance records are not maintained for standpipe and pre-connected hose systems. Obviously, eliminating the need for extended hose lays from the fire department apparatus to the fire location on an upper floor in a high-rise building would improve manual fire fighting operations. While pre-connected hoses are provided in many buildings, including WTC 1, 2, and 7, concerns over reliance on these hoses and their use by building occupants has been a long standing debate. In some jurisdictions, only Class I or similar standpipe systems are permitted, for use only by the fire department. In addition, standpipe systems are not considered to be an alternative to automatic fire suppression, e.g., automatic sprinklers.

3.3 NYC WATER SUPPLY

The primary source of all water for the fire suppression systems in WTC 1, 2, and 7 was the New York City (NYC) water supply and distribution system. This system was operated by the New York City Department of Environmental Protection (NYC DEP). Two separate divisions (bureaus) of the DEP were responsible for the water supply and distribution system: The Bureau of Water Supply (BWS) and the Bureau of Water and Sewer Operations (BWSO) (LZA Technology 2002).

The NYC water distribution system in lower Manhattan surrounding the WTC complex was composed of a grid network of 20 in. and 12 in. ductile iron mains. Figure 3–2 shows a plan of the system in the area surrounding the WTC complex. A 20 in. loop was located beneath the streets surrounding the main WTC complex where towers WTC 1 and WTC 2 were located. The mains were beneath Vesey Street to the north, Liberty to the south, Church Street to the east, and West Street to the west. These mains were interconnected to a series of 20 in. and 12 in. mains. This permitted water to flow along a large number of paths, minimizing the effects of friction loss while flowing a large volume of water. The large volume of water within the distribution system mains, transmission mains, and at the source (watersheds in upstate New York) allowed for a large capacity of water to be available for fire fighting capabilities. A 20 in. water main was located beneath West Broadway, immediately to the east of WTC 7. This main supplied water to the 20 in. loop around the WTC plaza. A 12 in. main to the west of WTC 7 beneath Washington Street supplied two parallel 8 in. diameter lead-ins (feeder mains) for WTC 7 and connected to a 12 in. main at the north side of WTC 7 beneath Barclay Street and the 20 in. main beneath Vesey Street. The 12 in. main on Barclay Street increased to a 20 in. diameter pipeline near the center of WTC 7 at Greenwich and interconnected to the 20 in. main on West Broadway. A 12 in. and a separate 20 in. parallel main connected to the 20 in. water main on Barclay and continued to the north on Greenwich. This arrangement of the water distribution system provided a near constant pressure for all flows that are normally anticipated for fire protection system demands (typically 500 gpm – 750 gpm), with a residual pressure that was nearly identical to the static pressure.

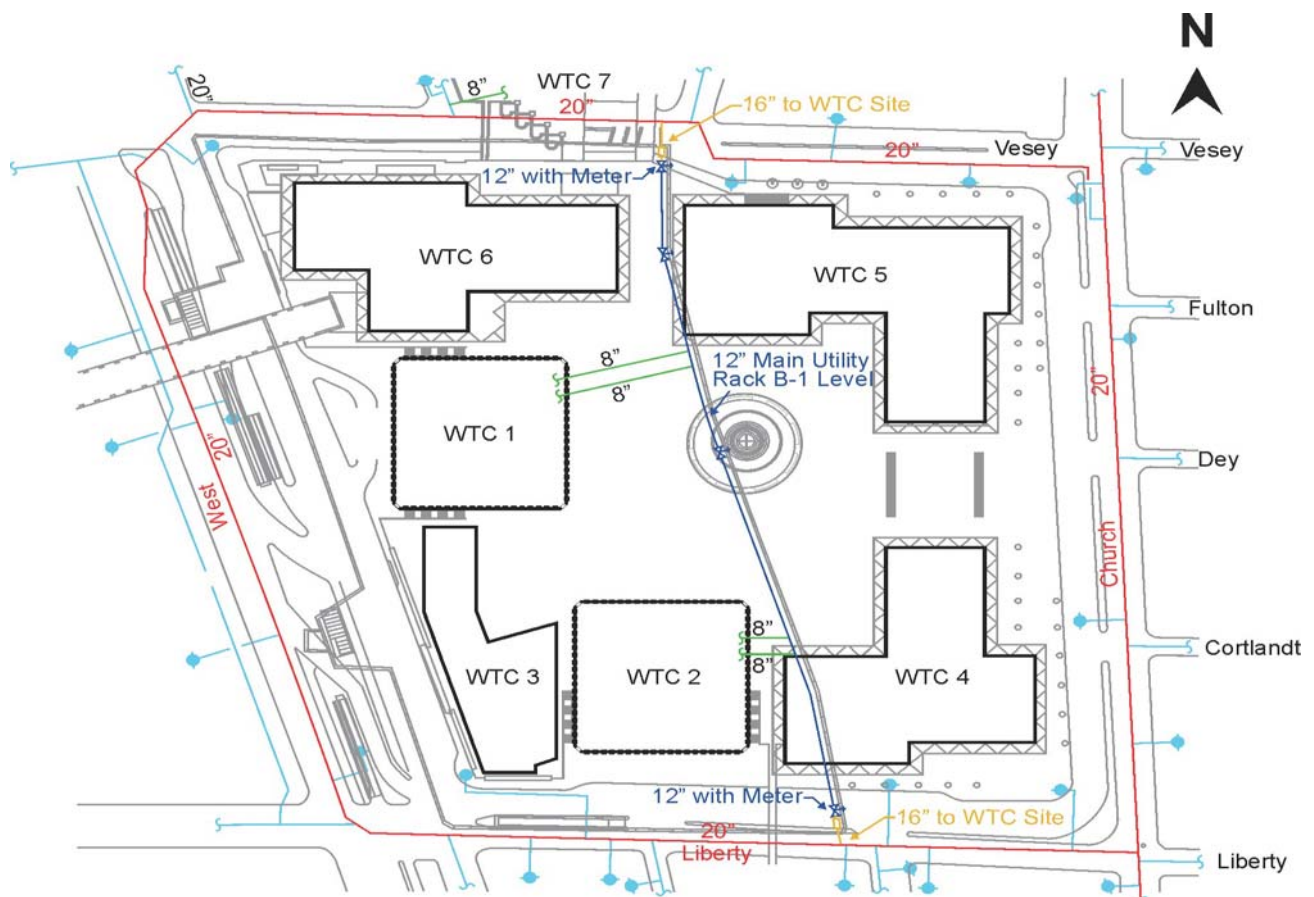

Source: LZA Technology 2002; Beyler 2002. Reproduced with permission of the Silverstein Properties Group.

Figure 3–2. Plan of water distribution system surrounding the WTC complex.

3.4 WTC 1 AND WTC 2 INSTALLED FIRE SUPPRESSION FEATURES

Through review of available information (PANYNJ 1987, 1972), the major features of the fire suppression systems installed in WTC 1, 2, and 7 on September 11, 2001, were documented. These systems included the water supplies, automatic sprinkler systems, standpipe and pre-connected hose systems and special fire suppression features.

3.4.1 Overview

WTC 1 and WTC 2 were protected by automatic fire sprinkler systems, essentially throughout. The sub-grade areas of the complex were provided with sprinkler systems during the initial construction. The systems were not installed in the towers during construction of the two buildings, but were retrofitted. The retrofit program had been completed prior to September 11, 2001.

In addition to automatic fire sprinkler systems, each building had vertical standpipe systems located in the stairwells. The standpipe systems were configured with four vertical water supply zones and included three standpipe risers in each zone.

The standpipes provided fire suppression water to pre-connected hoses located in the stairwells at each floor. WTC 1 and WTC 2 were equipped with standpipe systems which included Class III pre-connected hose stations in all exit stair enclosures and in certain corridors and tenant spaces. Each hose station was provided with a standpipe hose control valve, a 100 ft long fire hose, and a nozzle for use by a trained fire brigade or The Fire Department of the City of New York (FDNY).

The primary water supply for the standpipe systems was initially gravity fed from reserve water storage tanks located above the standpipe system zone. Also, a series of manually operated fire pumps provided water supplied by the NYC water distribution system. The primary water supply consisted of a fire main that looped the WTC complex. The 12 in. diameter main was supplied directly from the municipal water supply by two redundant 16 in. diameter connections. Operating pressures were maintained by two 750 gpm high-pressure electric pumps that supplied the sub-grade loops and were located beneath the towers on the B1 level of the complex.

Each tower had three 750 gpm manually initiated electrical fire pumps, located on the 7th, 41st, and 75th floors to supplement standpipe pressures. Each pump provided sufficient pressure for the standpipes to skip the next sequential pump above it if any failed to operate. In addition to the pumps, a single 500 gpm automatic fire pump was provided in each tower on the 108th floor for the sprinkler systems located on the 99th through 107th floors and the hose stations in the mechanical rooms on the 108th through 110th floors. Six emergency power generators were located in the basement at the B-6 level. These generators provided back-up power to the fire pumps, as well as to communications equipment, elevators, and emergency lighting.

Each reserve water supply consisted of 5,000 gal storage tanks, filled from the building's domestic water system. Figure 3-3 shows one of the installed tanks. Tanks were located on the 20th, 41st, 75th, and 110th floors in each tower. The tanks supplied the initial water supply to the WTC fire brigade or the FDNY. Without supplemental water supplied by the domestic water system, the tanks provided approximately 10 min for The Port Authority of New York and New Jersey (PANYNJ) maintenance staff to manually start the fire pumps.



Source: Merritt & Harris, Inc. 2000. Reproduced with permission of The Port Authority of New York and New Jersey.

Figure 3–3. Typical 5,000 gal water storage tank, WTC 1 and WTC 2.

Fourteen FDC stations were located at ground level for use by the FDNY to supplement the water supply and pressure to the fire suppression systems in the buildings. Any of the FDC stations could be used to supply the standpipe systems throughout the complex or sprinkler systems in WTC 1 and WTC 2 above the 32nd floor level. Isolation valves were installed between consecutive FDC stations. This provided independent supply and operation of the standpipe systems throughout the WTC complex. Two additional express FDC stations were provided to supply only the sprinkler systems in WTC 1 and WTC 2 above the 32nd floor level, and two separate FDC stations were provided for the sprinkler systems in WTC 1 and WTC 2 at and below the 31st floor level.

Several types of special suppression systems were installed in WTC 1 and WTC 2 on a limited basis to protect specific areas. These systems included:

- Dry chemical and steam smothering systems
- Carbon dioxide (CO₂) systems
- Halon 1301 total flooding systems

These systems were supervised by the fire alarm systems in WTC 1 and WTC 2 and were designed to transmit signals to the FDNY upon activation.

Restaurant cooking appliances were equipped with dry chemical fire suppression systems (PANYNJ 1987). These systems contained dry chemical fire suppression agents (potassium bicarbonate or ammonium phosphate). The dry chemical agents were stored in cylinders and would be released by an actuator that would discharge the agent upon fusing of a thermal link located above the cooking appliance or within the exhaust duct. The dry chemical systems were also provided with manual release mechanisms to allow for the occupants to actuate the systems manually. The Operation and Maintenance

(O&M) manual (PANYNJ 1987) described that these systems were installed in WTC 1 and WTC 2, but again did not identify specific locations.

The use of steam systems for fire suppression preceded the use of CO₂ and dry chemical fire suppression systems (PANYNJ 1987). The exhaust ducts in the large kitchens at the WTC complex were equipped with steam smothering systems. The O&M manual indicated that steam smothering systems were installed in the kitchens at the following locations:

- PANYNJ Cafeteria
- The “Big Kitchen”
- The Sky Dive
- Windows On The World
- The New York State Cafeteria
- The Observation Deck

Carbon dioxide is electrically nonconductive and is commonly used to extinguish fires involving electrical equipment; hence, CO₂ suppression systems were installed in computer rooms in WTC 1 and WTC 2. Smoke and heat detectors were used to actuate the releasing mechanism, causing CO₂ to discharge into the room. In particular, a total flooding CO₂ system was used to protect the under floor space of a large computer room in WTC 2 (PANYNJ 1987). The O&M manual contains a reference to other systems at the WTC complex, but it did not indicate their locations. Local alarm bells were provided to indicate to the occupants that the system had activated and the room should be evacuated.

Halon 1301 total flooding systems were used for the protection of computer rooms in WTC 1 and WTC 2. Halon is stored in holding cylinders, which are actuated upon the response of two cross-zoned smoke detectors. The O&M manual identifies that two separate cross-zoned detection system zones that were installed, and release occurred upon activation of a detector within both zones. The available drawings for WTC 1 show that two Halon 1301 systems were installed for protection of the computer room on the 70th floor. One system was installed for protection of the under floor space and the other for protection of the room (PANYNJ 1987, 1972).

3.4.2 Details of the Sprinkler and Standpipe Riser System

The sprinkler and standpipe riser system provides water for automatic and manual fire suppression. Figure 3–4 shows the major features and connections of the riser system in WTC 1 and WTC 2. The standpipe system contained four vertical zones and the sprinkler system three zones. Using Fig. 3–4 as a reference, the normal operation of the system in each zone is discussed below.

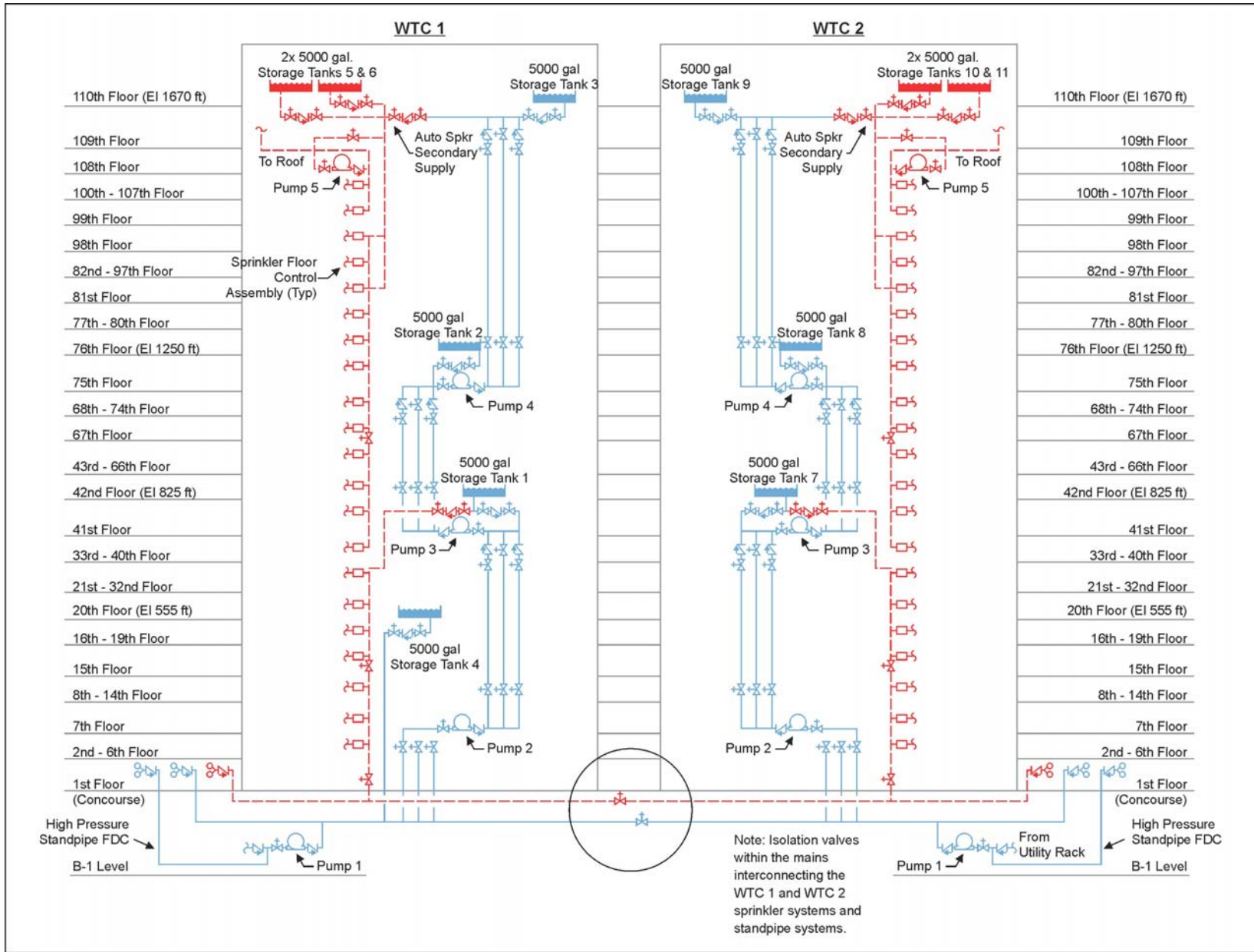

Figure 3-4. WTC 1 and WTC 2 sprinkler and standpipe risers.

Tanks and Pumps

Four reserve water storage tanks were provided in WTC 1 to supply the standpipes (PANYNJ 1987, 1972). Each tank had a holding capacity of 5,000 gal for a total of 20,000 gal of water dedicated for manual fire suppression (PANYNJ 1987, 1972). These tanks were located on floors 20, 41, 75, and 110 (PANYNJ 1987, 1972). The tanks were designated FSP storage tank No. 20A, FSP storage tank No. 1A, FSP storage tank No. 75A, and FSP storage tank No. 110A, respectively (PANYNJ 1987).

Three reserve water storage tanks were provided in WTC 2 to supply the standpipes. These tanks were located on floors 42, 76, and 110 (PANYNJ 1987, 1972). The tanks were designated FSP storage tank No. 41B, FSP storage tank No. 75B, and FSP storage tank No. 110B, respectively (PANYNJ 1987). Similar to WTC 1, each of the tanks had a holding capacity of 5,000 gal of water. The total holding capacity of the tanks in WTC 2 was 15,000 gal.

Two parallel 5,000 gal water storage tanks were provided on the 110th floor in each of the towers (PANYNJ 1987, 1972). These tanks provided a dedicated water supply of 10,000 gal for the high and mid-level zone sprinkler systems. The 5,000 gal standpipe reserve water storage tank on the 110th floor level also served as secondary automatic water supply for the high and mid-level automatic fire sprinkler systems.

The 5,000 gal water storage tanks located in the 41st floor level mechanical rooms were arranged to provide the primary water supply for the low zone sprinkler systems and the standpipe system zone serving floors 8 through 31. Therefore, a minimum of 5,000 gal was provided for the standpipe and sprinkler systems in each tower. Since each tank was also equipped with a 2 in. diameter automatic fill line supplied by the domestic water system, the volume of water in the tank would be partially replenished as the water was depleted from the tank.

The WTC complex was provided with 12 fire pumps and a single vertical turbine jockey pump (PANYNJ 1987, 1972). These pumps provided means to move water vertically in the building using the standpipe and sprinkler system risers. The primary water supply for most pumps were the water mains. Fire department engines could pump water from hydrants into the buildings through FDCs. The WTC complex was provided with 14 separate FDC stations, with a total of 32 FDCs (PANYNJ 1987, 1972).

The standpipe system reserve storage tanks located in the 75th and 41st floor level mechanical rooms were configured to serve as secondary manual water supplies for the high and mid-level zone automatic sprinkler systems (PANYNJ 1987, 1972). The use of these storage tanks required the manual starting of the fire pumps to lift the water to the 110th floor level (PANYNJ 1987, 1972). Any two manual fire pumps operating in series were capable of providing adequate capacity and pressure to supply the fire protection (suppression) systems within the high or mid-level sprinkler or standpipe systems (PANYNJ 1987, 1972).

A single fire (booster) pump was provided in each tower at the 108th floor level for the high zone sprinkler systems, and the hose racks were located on the 110th floor level (PANYNJ 1987, 1972). The suction line for each of the fire pumps received water from the sprinkler and standpipe reserve water storage tanks located in the mechanical rooms on the 110th floor. The 15,000 gal combined water capacity within those tanks was capable of supplying water to the booster pump at a flow rate of 500 gpm

(the 100 percent capacity of the fire pump) for a minimum duration of 30 min without any supplemental water being supplied by the domestic water system. This duration would be reduced to 20 min if the pump was operating at 750 gpm (the 150 percent capacity of the fire pump) which is the maximum required flow rate for a 500 gpm pump.

Automatic Fire Sprinkler and Standpipe Systems

Each tower contained three separate standpipe risers to supply water to the hose stations located on floors 1 through 110. One standpipe riser was provided in each exit stair enclosure. Table 3–1 provides a summary of the standpipe designations and locations. Standpipe risers FS-F1, FS-F2, and FS-F3 were located within and supplied water to pre-connected hose racks located in each respective stair enclosure (PANYNJ 1972, 2000). Figure 3–5 shows a typical hose rack arrangement with a typical intermediate isolation valve. Standpipe riser FS-F1 also supplied water to auxiliary hose cabinets located in the corridors and tenant areas of both buildings (PANYNJ 1972, 2000).

Table 3–1. Standpipe designations and locations, WTC 1 and WTC 2.

Tower	Stair Enclosure	Standpipe Riser Designations	Location of Stair Enclosure
WTC 1 (A)	Stairway B (3)	FS-F1	South
	Stairway C (2)	FS-F2	Northwest
	Stairway A (1)	FS-F3	Northeast
WTC 2 (B)	Stairway B (3)	FS-F1	East
	Stairway C (2)	FS-F2	Southwest
	Stairway A (1)	FS-F3	Northwest

The standpipe systems within each tower were installed with four vertical water supply zones:

1. High or upper
2. Upper mid-level
3. Lower mid-level
4. Low (PANYNJ 1987, 1972)

Table 3–2 identifies the zones. In the initial operating mode with water supplied from the water storage tanks only, each of these standpipe system zones functioned separately from the other zones. A series of check valves were installed between zones that prevented water from flowing downward from one zone to the next (PANYNJ 1987, 1972). In other operating modes, water was permitted to flow upward from one zone to the next. The manual fire pumps were used to supply water from the NYC water distribution system to all floors within either tower (PANYNJ 1987, 1972). The FDCs were also used by the FDNY to supply water to the standpipe systems from the ground level. Further information on the operation of the standpipe system in each vertical zone is presented in the technical experts' report (NIST NCSTAR 1-4B).

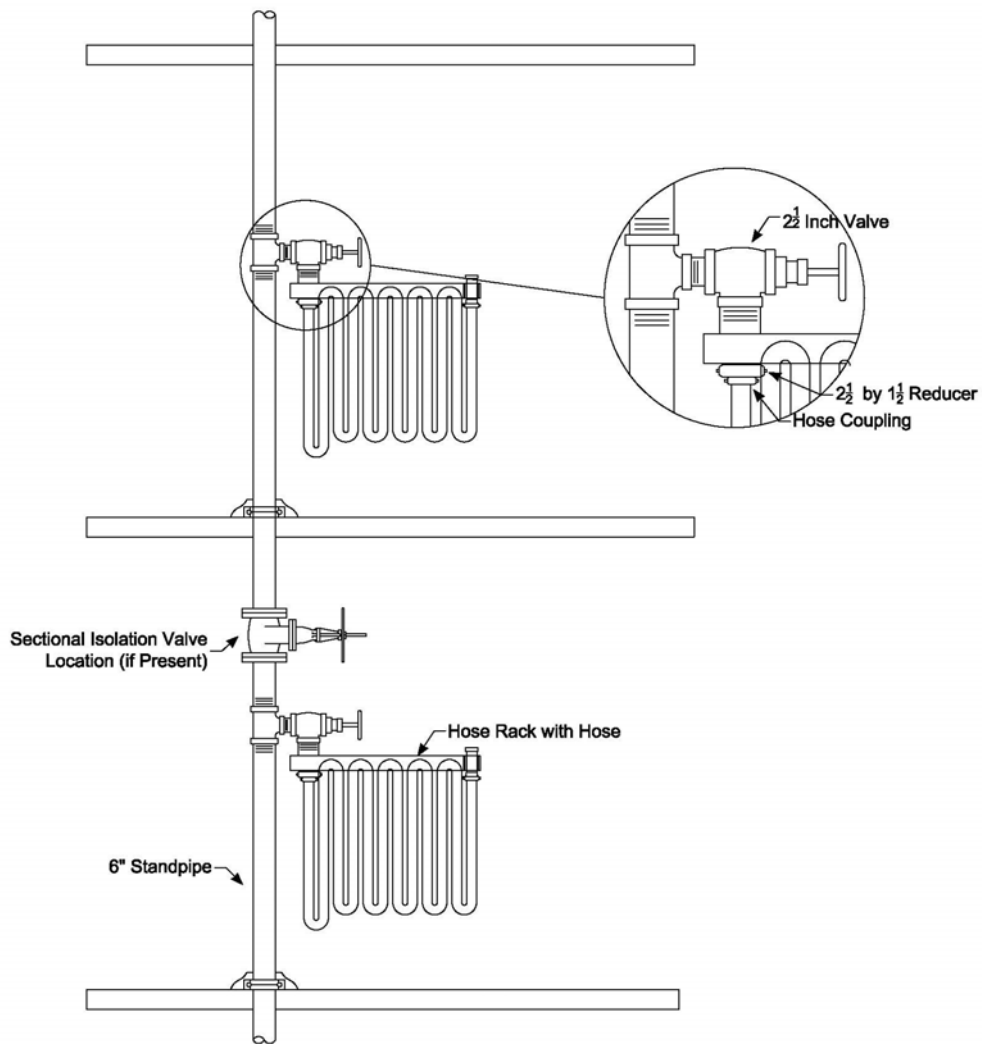

Figure 3–5. Typical hose rack arrangement.

Table 3–2. Standpipe system zones, WTC 1 and WTC 2.

	Zone	Description	Lower Floor	Upper Floor	Notes
WTC 1 (A)	1	High	77	110	Floor 75 was occupied by a 2-story MER
	2	High mid-level	42	76	Hose rack on FS-F1 only
	3	Low mid-level	9	41	Floor 41 was occupied by a 2-story MER
	4	Low	1	8	Floor 7 was occupied by a 2-story MER
WTC 2 (B)	1	High	77	110	Floor 75 was occupied by a 2-story MER
	2	High mid-level	42	76	Hose rack on FS-F1 only
	3	Low mid-level	9	41	Floor 41 was occupied by a 2-story MER
	4	Low	1	8	Floor 7 was occupied by a 2-story MER

The sprinkler systems for the towers were configured such that each floor level was provided with an independent sprinkler system (PANYNJ 1972). These sprinkler systems were supplied with water from a single shared sprinkler riser within the vertical water supply zones (PANYNJ 1972). The primary “automatic” water supply for each zone was provided from a series of gravity supplied water storage tanks dedicated to the automatic sprinkler systems or combined with the standpipe systems (PANYNJ 1987, 1972).

Separate sprinkler and standpipe risers were provided, even though the two systems shared the standpipe system infrastructure to provide water in addition to the initial reserve water supply stored in the gravity tanks (PANYNJ 1972). These systems were unlike most typical “combined systems” that have both sprinkler system floor control valve assemblies and standpipe hose valves directly connected to the same risers. In this case, the standpipe systems served as the secondary or tertiary water supplies for the sprinkler systems, depending on the riser (PANYNJ 1987, 1972). Both the FDCs and manual pumps could be used simultaneously to supply water to the standpipes and automatic fire sprinkler systems (PANYNJ 1987, 1972).

Existing documentation refers to the sprinkler systems as having two separate vertical zones with three risers (PANYNJ 1987, 1972). The zones are identified as the high zone and the low zone. However, the high zone was separated into two sub-sections using two separate risers. Therefore, the buildings were actually separated into three vertical water supply zones. These zones are referred to as the high, mid-level, and low zones in this report. Each zone was provided with a separate sprinkler system riser as identified in Table 3–3. Figure 3–4 illustrates the configuration of the risers within WTC 1 and WTC 2. In all cases, the primary direction of water flow was downward from the top of the riser to the sprinkler systems. However, the low zone risers were arranged to allow water to flow upward while using a secondary water supply.

Table 3–3. WTC 1 and WTC 2 sprinkler system risers.

Zone	Riser	Lower Floor	Upper Floor
High	A	99	107
Mid-level	B	98	33
Low	C	32	1

Each sprinkler riser was supplied with water through a single connection to the standpipe system. Risers A and B in both towers were connected to the water storage tanks and standpipe system on the 109th floor (PANYNJ 1987, 1972). Riser A in each tower is referred to in this report as the high zone. Similarly riser B is referred to as the mid-level zone. Riser C was connected to the combined standpipe and sprinkler system tank on the 41st floor level and supplied water to the low zone in each tower. The A risers were different from the other gravity supply risers, since these risers were equipped with small booster pumps located on the 108th floor level. Additionally, the A risers supplied standpipe hose stations on the 110th floor.

Sectional isolation valves were provided at floor levels 1 and 15 for riser C of WTC 1 (PANYNJ 1987, 1972). A single sectional isolation valve was provided at floor level 67 in riser B of WTC 1. Sectional isolation valves were also provided at floor levels 1 and 15 for riser C of WTC 2. However, a single sectional isolation valve was provided at floor level 77 in riser B of WTC 2. Neither of the high zone (A) risers was provided with an intermediate sectional isolation valve.

Each of the individual floor level sprinkler systems were connected to the shared riser and water supply within each respective zone. Each system contained a floor control valve assembly separating it from the shared infrastructure. Figure 3–6 shows the configuration of a typical floor control valve assembly. In general, automatic fire sprinkler protection was provided throughout the WTC 1 and WTC 2 buildings, with the exception of the mechanical equipment room (MER) floor levels.

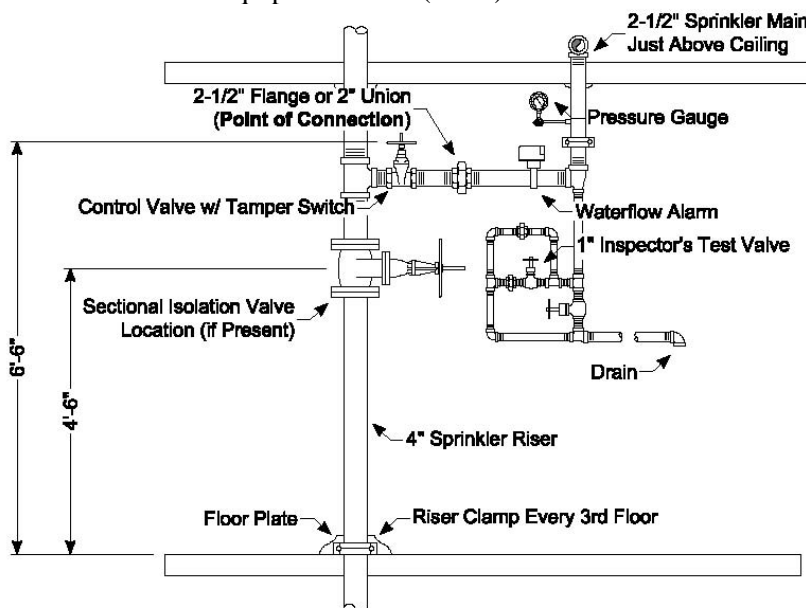

Source: Reproduced with permission of The Port Authority of New York and New Jersey.

Figure 3–6. Typical floor control valve assembly.

Documentation indicated that pendent sprinklers with chrome cover plates were installed in all finished areas (PANYNJ 1987, 2000). Figure 3–7 is a photograph of a typical concealed sprinkler cover plate. Exposed upright or pendent type sprinklers were installed in areas without finished ceilings. Sprinklers with an operating temperature rating of 165 °F were specified throughout most areas (PANYNJ 1987, 2000). Higher temperature rated sprinklers were specified in areas with normal ambient ceiling temperatures above 100 °F (PANYNJ 1987, 2000). Protective guards or shields would have been installed in areas where sprinklers were potentially subject to mechanical damage (PANYNJ 1987, 2000). Documentation indicated that ½ in. orifice sprinklers with a k-factor of 5.6 gpm/psi^{1/2} were installed throughout WTC 1 and WTC 2 (PANYNJ 1987, 2000). (The flow rate of water from a sprinkler is directly proportional to the water pressure to the half-power. K-factor is the proportionality constant in that relationship and is used in the design of sprinkler systems).



Source: NIST.

Figure 3–7. Typical concealed pendent sprinkler.

3.5 WTC 7 INSTALLED FIRE SUPPRESSION FEATURES

3.5.1 Overview

Available documentation and drawings indicated that automatic fire sprinkler systems were installed in most areas of WTC 7; however, they were not installed in the electrical equipment spaces including switchgear, networking, and switchboard rooms. Also, they were not installed in the generator rooms or bathrooms throughout the building. A majority of the fifth floor was not protected by sprinkler systems, with exception of the mechanical space to the east and the office area along the north side of the building (Syska & Hennessy 1984). Specifically, based on review of architectural drawings (Syska & Hennessy 1984) and O&M documents, no evidence was found to indicate that sprinklers were present in enclosures on the 5th, 7th, and 8th floors, which housed electrical generators and day tanks. Lack of sprinklers in these areas is likely the case since BCNYC allowed exclusion of automatic sprinkler protection in generator spaces.

A standpipe system was installed in each stairwell. Pre-connected hoses were located in the stairwells at each floor, connected to the standpipe. In addition, a supplemental pre-connected hose cabinet was located on the east side of each floor. Additional hose cabinets were installed in different locations on different floors in order to achieve the required reach for the hose lines. Three vertical zones are identified based on the water source and flow path.

The primary water supply for WTC 7 was provided by the 12 in. water main beneath Washington Street. FDCs were located on the south, east, and west sides of the building. A 750 gpm manual fire pump that served the entire building was located on the ground floor. A 500 gpm automatic fire pump, located on the ground floor, supplied the sprinkler and standpipe systems through the 20th floor. The 21st floor through 39th floor sprinkler systems and 21st floor through 44th floor standpipe systems were supplied from two gravity fed water storage tanks on the 47th floor. Each tank had a holding capacity of 17,500 gal and a fire reserve capacity of 7,500 gal. The 40th floor through 47th floor sprinkler systems and the 45th floor through 47th floor standpipe systems were supplied from the storage tanks on the 47th floor via a 500 gpm booster pump on the 46th floor.

Emergency power generators were located on several floors to provide back-up power to emergency systems in the building, including the fire pumps. The loading berth and fuel oil pump rooms in WTC 7 were protected by dry-pipe sprinkler systems. The first floor room containing the 6,000 gal fuel oil tank was protected by an Inergen clean agent fire suppression system. The telelevator storage area beneath the tank was protected by a wet pipe sprinkler system.

3.5.2 Details of the Standpipe and Sprinkler Riser Systems

Figure 3–8 shows a schematic diagram of the three zone WTC 7 water riser system. Check valves were located at the top of the low and mid-level zones for isolation. The check valves were oriented such that water from the automatic booster pump on the 46th floor could only supply the high zone, and the water storage tanks on the 46th floor could only supply the mid-level zone (Gensler and Associates 1995).

Tanks and Pumps

The combination system for the mid-level zone was primarily supplied with water from two 17,500 gal storage tanks. The water storage tanks were located on the 46th floor and extended up to the 47th floor level. The tanks were used as a domestic water storage system. However, each tank had a fire suppression system reserve capacity of 7,500 gal.

The make-up water to fill each tank was supplied by three 435 gpm capacity booster pumps via an 8 in. domestic express supply riser from the second floor. Each pump was provided with two float switches in each tank. A single pump operated when the water level dropped to a set point established by the electrode control unit. The pumps operated individually but would operate simultaneously if the load exceeded the capacity of one pump (Syska & Hennessy 1984). The tanks were combination domestic and fire water storage tanks. Therefore, the pumps would turn on at a certain drop in water level, due to domestic usage or fire water usage.

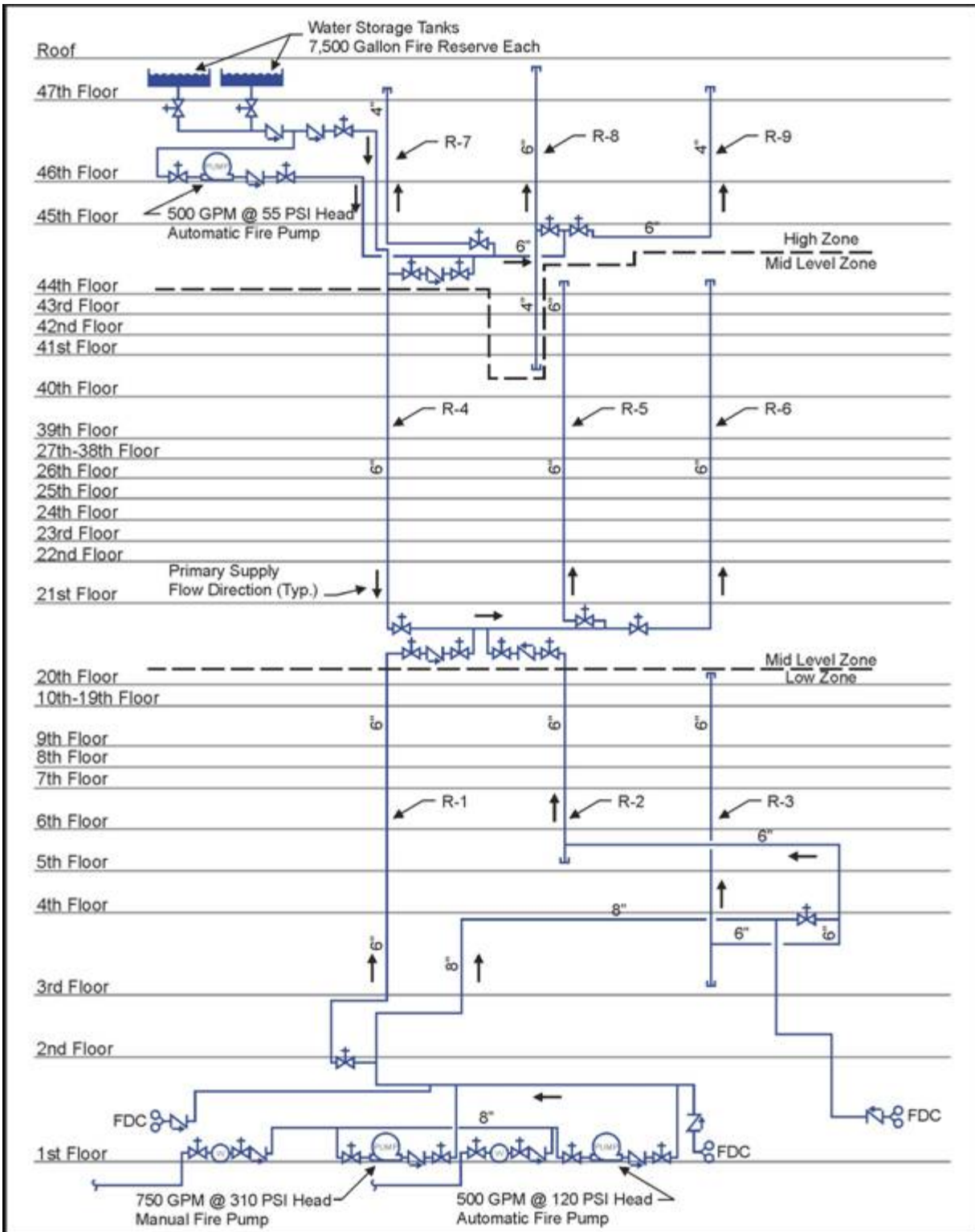

Source: Reproduced with permission of The Port Authority of New York and New Jersey.

Figure 3-8. WTC 7 water riser schematic.

Both domestic water storage tanks on the 46th floor were joined at the base by a connecting 8 in. pipe. A control valve was in place below each tank on the discharge piping, such that the tanks could be isolated from the system. The 8 in. pipe supplied the automatic booster pump on the 46th floor and the risers (R-4, R-5, and R-6) in the mid-level zone. The elevation of the storage tanks was approximately 600 ft above the first floor. The tanks provided a gravity fed supply to the base of risers R-5 and R-6 on the 20th floor (approximate elevation 255 ft) via standpipe riser R-4. Figure 3–8 illustrates the arrangement. The control valve at the base of riser R-4 would isolate the tank water supply from risers R-5 and R-6 if closed. Common practice would require valves to be provided to allow isolation of a standpipe without interrupting the supply to other standpipes for the same source of supply (NFPA 14).

The automatic booster pump on the 46th floor supplied the combination system risers in the high zone. The pump was a single stage pump rated for 55 psi at 500 gpm (Syska & Hennessy 1984). The water supply for the booster pump came directly from the water storage tanks.

An automatic fire pump on the first floor supplied the combination system risers, hose connections, and sprinkler control valve assemblies in the low zone. The water supply for the fire pump came directly from two separate 8 in. connections to the 12 in. main on Washington Street. The connections to the 12 in. main were separated using an isolation valve (Gensler and Associates 1995).

The pump was a single stage horizontal split case pump rated for 120 psi at 500 gpm. The pump was equipped with a 50 hp, 460 V, three-phase electric driver. The pump was provided with an emergency power source via an automatic transfer switch (Syska & Hennessy 1984).

A manual-start electrical fire pump was connected in parallel with the automatic fire pump on the first floor as illustrated in Fig. 3–8. The manual fire pump served as a secondary water supply for the entire combined system throughout the building (Gensler and Associates 1995).

Combination Automatic Fire Sprinkler and Standpipe Systems

WTC 7 had combined automatic sprinkler and standpipe systems, consisting of nine vertical risers in three zones. Each zone consisted of three risers, one combination sprinkler/standpipe riser and two standpipes for manual fire fighting. Therefore, the water supply for a particular zone was common for sprinkler piping and standpipes within that zone. The type, arrangement, and interconnection of the water supplies to the sprinkler systems and hose connections, including standpipe and sprinkler riser locations and zones of influence and isolation valves, are addressed in this section. System components such as valve type, pipe type, and valve locations are also described. Refer to Fig. 3–9 for the water supply riser configuration, valving arrangements, and vertical zones.

High Zone

The high zone included two standpipes and one combination riser that were supplied by an automatic booster pump on the 46th floor. The standpipes are identified as riser 7 (R-7) and riser 9 (R-9). The combination riser is identified as riser 8 (R-8). A cross connection main located on the 44th floor connected each riser. Each riser could be individually isolated from the cross connection main supplying each riser. Note the direction of flow in Fig. 3–8. The water discharged from the tank on the 46th floor, flowing down to the cross connection on the 44th floor where it fed each riser.

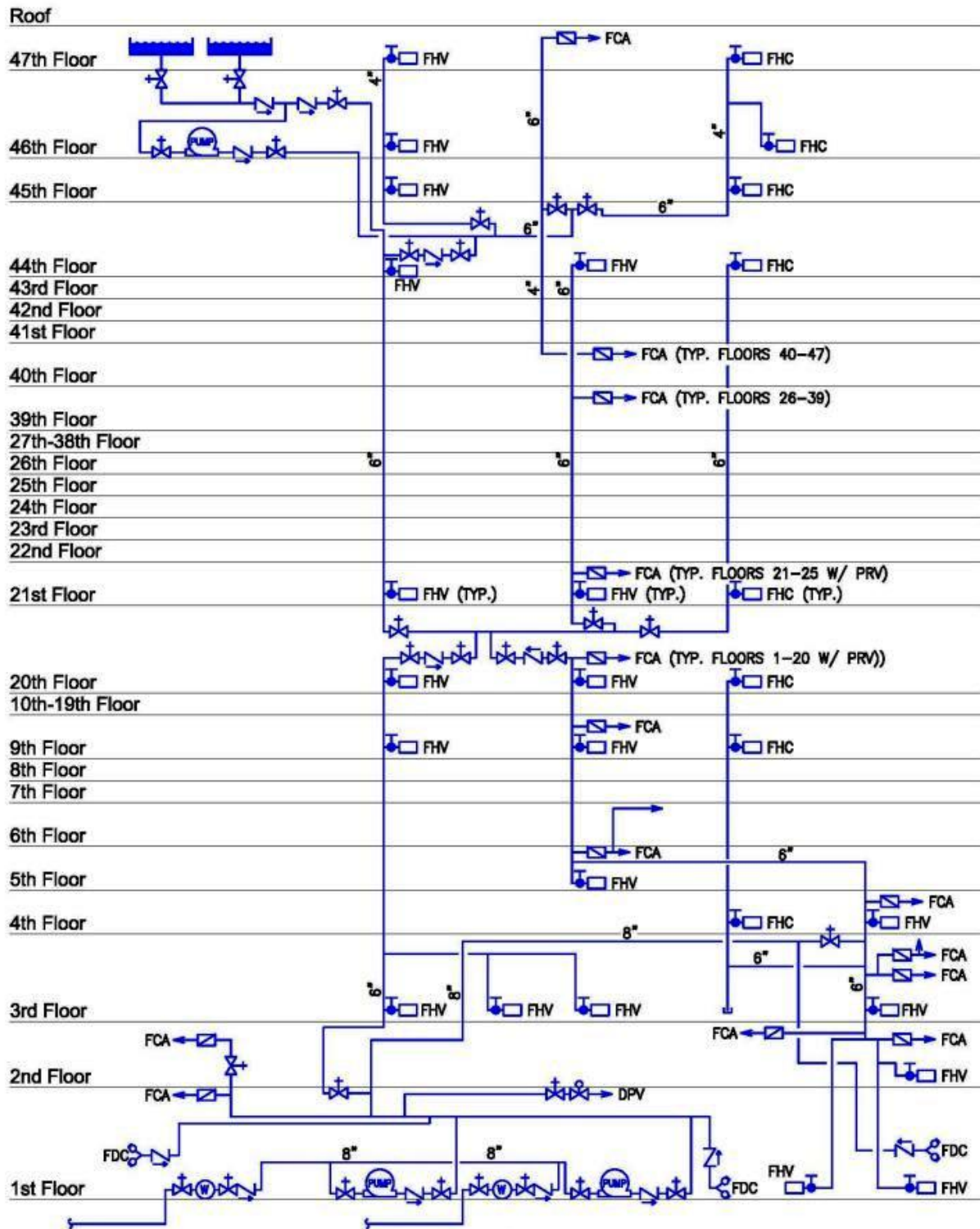

Source: Reproduced with permission of The Port Authority of New York and New Jersey.

Figure 3-9. Floor control valve and fire hose valve/cabinet locations, WTC 7.

Check valves were located at the top of riser 4 (R-4) of the mid-level zone at the connection with the high zone cross connection main. The check valve was oriented so that water could not flow from the high zone down to lower zones. However, the high zone could be served from lower zones through the check valve by the manual fire pump, which served as a secondary supply.

Figure 3–9 illustrates the vertical orientation of each riser in relation to the fire hose valves (FHV), fire hose cabinets (FHC) and floor control assemblies (FCA) on each floor. Riser 7 (R-7) was a 6 in. standpipe used for manual fire suppression activities. The standpipe was located in stair 1 on the west side of the building and extended from the isolation valve on the 44th floor through to the roof level. Riser 7 supplied FHVs on the 45th, 46th, and 47th floors and a 3 in. by 2½ in. manifold roof hydrant.

Riser 8 (R-8) was a combination sprinkler/standpipe riser located in stair 2 in the center of the building between the 40th floor through the 47th floor. Riser 8 was a 6 in. combination riser supplying the FCAs and FHVs between the 45th and 47th floors. It then was reduced to a 4 in. riser between the 40th and 44th floor where it only supplied the FCAs. Refer to Fig. 3–9. Riser 9 (R-9) was a 6 in. riser located in the utility shaft on the east side of the building. This riser extended from the isolation valve on the 44th floor to the FHC on the 47th floor and supplied FHCs on the 45th, 46th, and 47th floors.

Mid-Level Zone

The mid-level zone also included two standpipes and one combination automatic sprinkler/standpipe riser identified as riser 4 (R-4), riser 6 (R-6), and riser 5 (R-5), respectively. The gravity tanks on the 47th floor were the primary supplies for the mid-level zone.

A cross connection main located on the 20th floor connected the risers to each other. The isolation valves located at the base of risers 5 and 6 could be closed to isolate each riser, respectively. Riser 4 also had a riser isolation valve located at its base. However, the gravity tanks supplied riser 5 and 6 via riser 4 (Fig. 3–8). Therefore, closing the riser isolation valve at the base of riser 4 would also isolate risers 5 and 6 from their primary supply. Risers 5 and 6 were not connected at the top. Typical industry practice in this type of arrangement involving a tank supply would include standpipe interconnections at the top, as well as at the bottom, consistent with NFPA 14 Section 5-5 (2000 edition). Check valves would be installed at the bases of the standpipes in such a case to prevent circulation.

Check valves were located at the top of riser 1 (R-1) and riser 2 (R-2) of the low zone at the connection with the mid-level zone cross connection main. The check valves were oriented so that water could not flow from the mid-level zone down to the low zone. However, the mid-level zone could be served from the low zone through the check valves by the manual fire pump (which served as a secondary supply) or from excess pressure served by the city supply and automatic fire pump serving the low zone.

The following is a description of each mid-level zone riser and the systems that they served. Figure 3–9 illustrates the vertical orientation of each riser in relation to the FHVs, FHCs, and FCAs on each floor.

Riser 4 (R-4) was a 6 in. standpipe used for manual fire suppression activities in addition to serving as the primary supply for risers 5 and 6. Riser 4 was located in stair 1 on the west side of the building. Riser 4 supplied FHVs on the west side of the building from the 21st through the 44th floors.

Riser 5 (R-5) was a 6 in. combination sprinkler/standpipe riser. Riser 5 extended from the cross connection main on the 20th floor through the 44th floor. The riser was located in stair 2 through the 23rd floor. Riser 5 remained in stair 2 through the 44th floor, however, stair 2 shifted approximately 20 ft toward the west from the 24th through the 46th floors. Riser 5 supplied the FCAs and FHV's on each floor from the 21st through the 39th floors. Riser 5 only supplied the FHV's on the 40th through the 44th floors. Each FCA on the 21st through the 25th floors contained a pressure-reducing valve. The pressure-reducing valve regulated the high supply pressure produced by the manual fire pump to within the listed rating of 175 psi for the sprinkler piping. Riser 6 (R-6) was a 6 in. standpipe that supplied FHCs. This riser was located in the utility shaft below riser 9. It extended from the 21st through the 44th floors. The primary supply for riser 6 was from the water storage tanks on the 47th floor level via riser 4 and the cross connection main on the 20th floor.

Low Zone

The low zone included two standpipes and one combination sprinkler/standpipe riser. Additionally, sprinkler system FCAs and FHV's were located off of the infrastructure piping on the first through fourth floors. Refer to Fig. 3–9 for piping and valving arrangements. The standpipes and combination riser are identified as riser 1 (R-1), riser 3 (R-3), and riser 2 (R-2), respectively. The automatic fire pump located on the first floor was the primary supply for the low zone.

Riser 1 was connected to the discharge side of the pump manifold. The isolation valve for riser 1 was located in the first floor pump room. An 8 in. cross connection main extended from the first floor fire pump room, on the west side of the building, up to the third floor via stair 1. The cross connection extended to the east side of the building to an isolation valve in stair 2. Figure 3–8 illustrates that both risers 2 and 3 were controlled from a single isolation valve (Gensler and Associates 1995).

The following is a description of each low zone riser and the systems that it served. Figure 3–9 illustrates the vertical orientation of each riser in relation to the FHV's, FHCs, and FCAs on each floor.

Riser 1 (R-1) was a 6 in. standpipe feeding FHV's only. Riser 1 was located in stair 1 on the west side of the building. It extended from the 1st floor fire pump room through the 20th floor. On the fifth floor, riser 1 shifted further toward the center of the building with stair 1. Note the valving orientation at the top of riser 1. Water could feed the mid-level zone from riser 1 by flowing through the check valve. The mid-level and high zones could also be isolated from the system infrastructure by closing the isolation valves at the top of risers 1 and 2.

Riser 2 (R-2) was a 6 in. combination sprinkler/standpipe riser. Riser 2 was located in stair 2, which was located in the west side of the building through the fourth floor. Stair 2 then shifted to the center of the building on the fifth floor. Therefore, riser 2 also shifted to the center of the building on the fifth floor. Riser 2 supplied the FCAs and FHV's at the stair landings on the 5th through 20th floors. The top of riser 2 was equipped with a valving arrangement similar to that of riser 1, allowing isolation or flow to the mid-level cross connection. Also, each FCA on riser 2 was equipped with a pressure-reducing valve to regulate the pressure produced by the manual fire pump down to within the rated working pressure of the sprinkler piping.

Riser 3 (R-3) was a 6 in. standpipe that fed FHCs. Riser 3 was located in a utility shaft on the east side of the building below riser 6. It extended from the 3rd to the 20th floors. Riser 3 was only used to supply the FHCs on each floor; it was not connected to the mid-level cross connection as were risers 1 and 2.

3.6 CONSISTENCY WITH ENGINEERING BEST PRACTICES

An evaluation of the consistency of the documented sprinkler and standpipe system installations with applicable codes and standards provisions and state-of-the-art engineering “best practices” during the time of construction of the buildings was performed for WTC 1, 2, and 7. The intent of this evaluation was to determine if the installed suppression system infrastructure (excluding tenant space fit-outs that were not investigated) in these three buildings were designed and installed in a manner consistent with performance expectations associated with applicable codes and standards, as well as those related to recommended best practices at the time of the design and construction of the buildings. The results of this evaluation indicated that, according to the documents examined, the fire suppression systems in WTC 1, 2, and 7 were installed in a manner consistent with best practices in existence at the time of their installation. In recent years, there have been advances in sprinkler technology, such as faster responding sprinklers. Use of faster responding sprinklers available today would not have materially affected the design of the water supply, standpipe, and sprinkler riser systems that are the focus of this investigation.

3.7 WTC 1, 2, AND 7 SUPPRESSION SYSTEM INSTALLATION DIFFERENCES

WTC 1 and WTC 2 were constructed in the 1970s. Some of the fire suppression infrastructure was installed at that time. However, the automatic sprinkler systems were installed later, in the 1980s and 1990s. Construction of WTC 7 was completed in 1986, and all of the fire suppression features for WTC 7 were installed as part of the initial construction of the building.

The primary water source for all three buildings originated from the NYC water distribution system. The towers were supplied from the sub-grade loops on the north and south sides of the complex at two remote locations. The two mains provided redundant supplies and had isolation valves to allow for independent operation of either main without impairing the fire suppression systems in the WTC complex. Two mains located within 12 ft of each other supplied WTC 7 from the same NYC water distribution system main. The standpipe systems in all three buildings were similar in design to NFPA 14 Class III type standpipes. The primary difference between the sprinkler and standpipe systems in WTC 7 and those in the towers was that the sprinkler and standpipe systems in WTC 1 and WTC 2 were supplied by separate risers, and the sprinkler and standpipe systems in WTC 7 were combined. Both arrangements were permitted according to NFPA 14.

Multiple water supply zones were provided in each building. The standpipe systems in WTC 1 and WTC 2 included four vertical zones. The sprinkler system infrastructures in WTC 1 and WTC 2 included three vertical zones. The combined sprinkler and standpipe systems in WTC 7 had three vertical zones.

Water storage tanks were used as the primary water supplies for all sprinkler and standpipe system zones in WTC 1, 2, and 7, except for the low zones of WTC 7 which were supplied by the NYC water distribution system through a 500 gpm automatic fire pump. A single 750 gpm manual-start fire pump

was used as the secondary water supply for the combined sprinkler and standpipe systems in WTC 7. A series of four vertical 750 gpm manual-start fire pumps were used in each tower.

Sprinklers were provided essentially throughout all areas of WTC 1, 2, and 7. Sprinklers were omitted from the MERs in WTC 1 and WTC 2. The electrical, data/telephone, and generator rooms that were part of the core areas in WTC 7 were not protected by the wet pipe sprinkler systems. The sprinkler systems in all three of the buildings were designed and installed with looped mains and were capable of delivering robust discharge densities exceeding the code required minimum densities. Pressure reducing valves were used in all three buildings. Although the configurations were different, it is doubtful there were any significant advantages or disadvantages in the systems on September 11, 2001.

The types of special hazard fire suppression systems in each building were different, but no information was found that indicated these systems played a significant role in fire control or the loss of fire control on September 11, 2001. While limited information was available regarding the actual performance of the installed fire suppression systems on September 11, several design features were identified that could be improved upon in future installations. For example, in WTC 1 and WTC 2, the supply from the primary water storage tanks on the 110th floor to the sprinkler systems included a long horizontal length (greater than 100 ft) of 4 in. diameter pipe on the floor directly under the tanks that led to the vertical riser. Due to the associated friction loss in this long run of pipe, the flow was unnecessarily limited on the upper floors.

In WTC 7, the automatic sprinkler systems on floors 1 through 20 were supplied directly from the city distribution system through an automatic fire pump located on the 1st floor. Either a loss of power to the fire pump or significant damage to the underground city main in the vicinity of the building could interrupt the water supply to these sprinkler systems. A simple means of backing up the primary water supply for floors 1 through 20 would have been to provide secondary access to the stored water on the upper floors of the building. There is not enough information about the initiating fires to determine if access to the stored water in the low zone of the building would have had a significant impact on the spread of the fires or on the FDNY decision not to fight the fires.

3.8 WATER SUPPLY CAPACITIES FOR WTC 1, 2, AND 7 SPRINKLER SYSTEMS

Hydraulic calculations were performed to evaluate the expected sprinkler system performance based on the configuration of the water supply. The objective of the analysis was to determine any variations in the performance of the sprinkler systems in each building and within each water supply zone. The initial water supplies for the systems were primarily gravity fed from stored water tanks. A group of sprinkler systems from each building was selected for analysis. Sprinkler systems near the top and the bottom of each water supply zone were selected to bound the effects of elevation on the performance of these sprinkler systems. In some cases, intermediate systems were also selected for evaluation because the arrangements of the systems varied as a result of using outside screw and yoke or pressure reducing type control valves. A commercial computer program, Hydraulic Analyzer of Sprinkler Systems, Version 7.5 was used to perform the calculations (HRS Systems 2004).

Several factors were examined as part of this analysis. Supply calculations were used as a means to compare the flow rate of water delivered from the primary and secondary supplies to the sprinkler systems. Calculations were also performed with variations in the number of sprinklers flowing water for

the highest and lowest floor level sprinkler systems to observe the effects on the discharge density of the sprinkler systems and water supply duration (i.e., how long the flow could be maintained). The intent of this analysis was to provide sufficient information to characterize the capabilities of the water supplies.

The automatic sprinkler systems were provided with both primary and secondary water supplies. In most cases the supply piping was configured to provide redundant supply paths to the water supply zones in the buildings. This arrangement would allow for continued sprinkler operability in the event that one of the supply paths was interrupted.

The results of the hydraulic calculations for the Light Hazard occupancy sprinkler systems in WTC 1 and WTC 2 (see Table 3–4) indicated that the expected water densities and duration of the water supplies exceeded the baseline levels customarily provided for fire hazards represented by high-rise office building occupancies (0.10 gpm/ft²), with supply densities ranging from 0.10 to 0.27 gpm/ft² with up to 16 open sprinklers. The associated flow rate could be maintained from the primary water supply source for approximately 10 to 89 min, depending on the location and number of open sprinklers.

Table 3–4. Results of hydraulic calculations.

Building	Occupancy Hazard	Number of Open Sprinklers	NFPA 13 Delivered Density (gpm/ft ²)	Calculated Delivered Density (gpm/ft ²)	Calculated Duration (min)
WTC 1 and WTC 2	light	4	0.10	0.14 – 0.27	33 – 89
WTC 1 and WTC 2	light	8	0.10	0.13 – 0.18	18 – 39
WTC 1 and WTC 2	light	16	0.10	0.10 – 0.15	10 – 33
WTC 1 and WTC 2	ordinary	4	0.15	0.33 – 0.56	18 – 61
WTC 1 and WTC 2	ordinary	15	0.15	0.22 – 0.38	8 – 27
WTC 1 and WTC 2	ordinary	25	0.15	0.15 – 0.22	9 – 26
WTC 7	light	4	0.10	0.17 – 0.38	87 – 133 ^a
WTC 7	light	9	0.10	0.16 – 0.22	45 – 61 ^a
WTC 7	light	18	0.10	0.11 – 0.16	31 – 45 ^a

a. Duration for low zone is controlled by the availability of the NYC water supplied.

Similarly, the results of the calculations for Ordinary Hazard Group 1 sprinkler systems in WTC 1 and WTC 2 indicated that a density ranging from 0.15 to 0.56 gpm/ft² could be provided for up to 25 open sprinklers for 9 to 61 min. The delivered density specified in the model code for Ordinary Hazard occupancies is 0.15 gpm/ft².

The results of the calculations using the Light Hazard criteria for the sprinkler systems in WTC 7 indicate that the available water density ranging from 0.17 to 0.38 gpm/ft² could be maintained for four open sprinklers for 87 to 133 min. A density of 0.16 to 0.22 gpm/ft² could be provided to nine open sprinklers for 45 to 61 min. And a density of 0.11 to 0.16 gpm/ft² could be provided to 18 open sprinklers for 31 to 45 min. The durations do not apply to the low zone sprinkler systems because water was supplied from an automatic fire pump drawing suction directly from the NYC distribution. Therefore, the supply would be continuously provided as long as the water distribution and electrical systems were intact and operational.

Details of the hydraulic calculations can be found in the technical expert's report (NIST NCSTAR 1-4B).

3.9 SUPPRESSION SYSTEM PERFORMANCE UNDER SELECTED FIRE SCENARIOS

As a baseline for further understanding of the performance of the installed fire suppression systems, and specifically understanding the limitations with respect to the fires on September 11, 2001, the expected performance of the automatic sprinkler systems and the standpipe/pre-connected hose systems in WTC 1, 2, and 7 was analyzed for selected fire scenarios. A lack of performance criteria and history for standpipe systems limited the evaluation of the pre-connected hoses.

Hydraulic analyses relied on the minimum delivered density and pressure requirements in NFPA 13 as the basic criteria for evaluating the fire control capacity of the sprinkler systems. It is important to recognize that in NFPA 13 the required densities and pressures are based on the assumption that an installed fire sprinkler system is designed to control a single fire. In addition, in the analyses performed here, small fires were assumed to be approximately the size of the area covered by a four-sprinkler array (i.e., approximately 750 ft²). In fact, available performance history indicates that typical fires in high-rise office buildings are controlled or suppressed by less than four sprinklers, lending additional conservatism to the estimates of system capacity presented here. Finally, the calculations were based on availability of the primary water supplies only, without any consideration for fire department actions to provide a secondary water supply.

In NYC such action is routine, and the secondary water supply is considered infinite in duration, with equivalent or higher capacity to the primary water supply. At the same time, due to the normal availability of a reliable, high capacity secondary water supply, duration of water supply was not included in this analysis.

3.9.1 Scenarios

Hydraulic calculations using the supply calculation approach were used to analyze the capacity of the water supply to the sprinkler systems in WTC 1, 2, and 7 (NIST NCSTAR 1-4B). For a supply calculation, the water supply and sprinkler system configuration are given. The water flow from the supply is relayed forward through the system, overcoming the pressure losses due to friction and elevation, until the water discharges from the designated sprinklers. Supply calculations are used to show the actual or maximum discharge density that the water supply is capable of delivering to the sprinkler system.

It was considered impractical to perform hydraulic calculations for every floor and every subsystem. Therefore, representative system configurations were selected to represent conditions within each water supply zone. Configurations were chosen to provide bounding results (in terms of available pressure, flow and duration) for each vertical hydraulic zone in the buildings.

This approach limited the number of cases to a manageable level and at the same time provided representative results applicable to any location in the buildings. The results also provided the baseline information needed to evaluate the performance capabilities of the sprinkler systems. The calculations were based on the following bounding conditions for each vertical zone:

Water Supply

- Primary—water storage tanks and/or automatic fire pumps
- Secondary—manual fire pumps or water storage tanks

Number of Operating (Opened) Sprinklers

- Four sprinklers—smaller than the required design area
- Eight to 15 sprinklers—design area for light or Ordinary Hazard Occupancy
- Eighteen to 25 sprinklers—larger than the required design area

Floor Level within the Vertical Zone

- WTC 1 and WTC 2
 - 107th floor (highest floor system in high water supply zone)
 - 99th floor (lowest floor system in high water supply zone)
 - 98th floor (highest floor system in mid-level water supply zone)
 - 87th floor (lowest floor system in mid-level water supply zone without a PRV)
 - 86th floor (highest floor system in mid-level water supply zone with a PRV)
 - 32nd floor (lowest floor system in mid-level water supply zone with a PRV)
 - 31st floor (highest floor system in low water supply zone)
 - 9th floor (lowest floor system in low water supply zone without a PRV)
 - 7th floor (highest floor system in low water supply zone with a PRV)
 - 2nd floor (lowest floor system in low water supply zone with a PRV)
- WTC 7
 - 47th floor (highest floor system in high water supply zone)
 - 40th floor (lowest floor system in high water supply zone)

- 39th floor (highest floor system in mid-level water supply zone)
- 21st floor (lowest floor system in mid-level water supply zone)
- 20th floor (highest floor system in low water supply zone)
- 1st floor (lowest floor system in low water supply zone)

Each combination of the conditions listed above was used to develop supply calculations. The supply calculations provided estimates of the actual water flow rate and pressure that would be expected based on typical sprinkler system arrangements. The duration was determined by dividing the storage capacity by the calculated flow rate. The calculations did not account for the supplemental make-up supplies from the automatic refill lines supplied by the domestic water supply systems. The results of these calculations were intended to approximate the actual delivered discharge densities based on representative sprinkler system layouts provided from the available documentation of the systems. The results are considered to more accurately represent the actual performance as compared to using the minimum required flow rates determined by multiplying the density times the design area specified by NFPA 13 for the applicable hazard.

Calculations for the sprinkler systems in WTC 1 and WTC 2 were performed for several different coverage areas based on the available documentation for the systems. The calculations for Light Hazard areas in WTC 7 used a coverage area of 168 ft². The calculations for all systems used $k=5.6 \text{ gpm/psi}^{1/2}$, ½ in. orifice sprinklers.

3.9.2 Results

Based on the analyses performed, the installed sprinkler systems in WTC 1, 2, and 7 had the ability to simultaneously control or suppress multiple fires of varying sizes under “normally expected” operating conditions. The fires could have occurred at different locations on a single floor or on multiple floors. The results indicated that the water flow density and pressure associated with the installed sprinkler systems had the capacity to control fires on the order of two to three times the sprinkler system design area (1,500 ft²) depending on the location in the building.

Simultaneous fires on different floors were examined as a challenging scenario to aid in understanding the performance limits of the sprinkler system. In the first scenario, which applied to either WTC 1 or WTC 2, it was assumed that the fires would open no more than four sprinklers. This was a conservative assumption, since most fires in high-rise office buildings are controlled or suppressed by less than four sprinklers. The floors to be analyzed started with the 39th floor. The 39th floor was chosen because it represents the hydraulically most demanding floor supplied from the primary water supply. Four sprinklers were assumed to have operated on each subsequent floor, incrementally. Table 3–5 provides a summary of the results of the calculations by comparing the average delivered density to the floor number for each multiple fire floor scenario.

Table 3–5. Average delivered density per floor vs. number of floors flowing (four sprinklers/floor).

Floor	39	38 & 39	37–39	36–39	35–39	34–39	33–39	32–39	31–39
39	0.168	0.164	0.158	0.149	0.140	0.129	0.116	0.102	0.086
38	-	0.176	0.170	0.162	0.154	0.144	0.132	0.120	0.107
37	-	-	0.178	0.171	0.163	0.154	0.144	0.133	0.122
36	-	-	-	0.181	0.174	0.165	0.155	0.146	0.135
35	-	-	-	-	0.184	0.176	0.168	0.159	0.149
34	-	-	-	-	-	0.188	0.180	0.171	0.162
33	-	-	-	-	-	-	0.190	0.182	0.174
32	-	-	-	-	-	-	-	0.193	0.184
31	-	-	-	-	-	-	-	-	0.196

It should be noted that the calculated average delivered density was still greater than the minimum required density for the case involving water flow on eight floors. The minimum residual sprinkler pressure was 8.8 psi for the eight-floor case. The minimum sprinkler pressure occurred on the 39th floor.

When a 9th floor was added (the 31st floor), the average delivered density on the 39th floor dropped below 0.10 gpm/ft² to approximately 0.087 gpm/ft². Also, the minimum sprinkler pressure on the 39th floor was 6.3 psi, 0.7 psi below the minimum pressure required by NFPA 13. Therefore, based on the minimum density and pressure selected for this analysis, up to eight fires (limited to an area covered by four sprinklers) could simultaneously occur in different locations or on different floors, and the installed sprinkler systems would be expected to control or extinguish them.

For larger simultaneous fires, the performance of the sprinkler systems was analyzed using multiple fires approximately equivalent to the design area, occurring at different locations, including on different floors. The design area was determined to be approximately 1,500 ft². Like the previous scenario, the floors to be analyzed started with the 39th floor. Table 3–6 provides a summary of the calculation results.

Table 3–6. Average delivered density per floor vs. number of floors flowing (nine sprinklers/floor) for WTC 1 and WTC 2.

Floor	39	38 & 39	37–39	36–39	35–39
39	0.162	0.147	0.129	0.108	0.087
38	-	0.160	0.143	0.126	0.107
37	-	-	0.143	0.128	0.114
36	-	-	-	0.140	0.126
35	-	-	-	-	0.139

Based on these results, the sprinkler system could deliver more than the minimum required density over a design area of 1,500 ft² for up to four simultaneous fires on the same or different floors. The calculated average delivered density dropped below 0.10 gpm/ft² when a fifth fire was included in the calculations. The minimum residual sprinkler pressure for the five floor calculation occurred on the 39th floor. The minimum residual sprinkler pressure on the 39th floor, assuming fires on all five floors, was 5.7 psi.

The results in Table 3–5 indicate that sprinklers within the required design area could be activated on four different floors or at four separate locations on one floor and the system would still have had the capacity to deliver more than the minimum required density. The fire hazard occupancy control approach to sprinkler system design, applicable to systems designed in accordance with NFPA 13, only requires the water supply to provide the minimum density to sprinklers that cover a single design area. The water supply system in WTC 7 was capable of supplying the minimum required density to all sprinklers within the design area for four separate fires, each roughly the size of the design area. This would normally be considered a very robust capability for an installed fire sprinkler system.

While it is difficult to assess the performance capabilities of the standpipe pre-connected hoses, hydraulic calculations indicated that the size of the standpipes and the capacity and number of fire pumps were consistent with the requirements for pressure and flow in the BCNYC for both WTC 1 and WTC 2. However, the booster pump on the 46th floor was undersized, and could not provide the higher minimum flow and pressure required in NFPA 14.

Details of the evaluation are contained in the technical expert's report (NIST NCSTAR 1-4B).

The calculations identified limits of performance, but the estimated performance was significantly greater than that required in NFPA 13. The available densities and pressures indicated that the installed systems generally exceeded the minimum requirements in NFPA 13 by significant margins. These systems would have been expected to control multiple small fires or single large fires up to two or three times the sprinkler system design area, and would have been considered robust installations with considerable excess capacity. At the same time, if large fires were to open all of the sprinklers in an area equivalent to two to three times the design area of the sprinkler systems, the hydraulic capabilities of the system(s) would degrade, and although these fire areas would be considered relatively large (i.e., 3,000 to 4,500 ft²), they represented roughly 8 to 15 percent of the area of a single occupied floor in WTC 1, 2, and 7.

Flow restrictions existed in the mid-level water supply zones in WTC 1 and WTC 2, but the limits of available water flow were still considerably higher than those required in NFPA 13 for control of typical Light Hazard fires.

3.10 ESTIMATES OF SUPPRESSION SYSTEMS PERFORMANCE ON SEPTEMBER 11, 2001

The likely performance of the automatic fire sprinkler and standpipe systems in WTC 1, 2, and 7 on September 11, 2001, was analyzed. A sequence of the five major events was used to structure this evaluation. These events included the separate aircraft impacts into WTC 1 and WTC 2, the collapse of WTC 2, the collapse of WTC 1, and the collapse of WTC 7.

The analysis attempted to answer four key questions in order to assess the performance of the systems on September 11, 2001.

1. What happened to the systems as a result of each major event?
2. What actions may have helped to maintain the systems operability?

3. How was the performance of the systems impacted by each event?
4. At what point in the sequence of events were the systems lost?

The damage to WTC 1 as a result of the aircraft strike was concentrated on floors 94 through 97. Based on best estimate analysis of impact damage (NIST NCSTAR 1-2B), the survival of sprinkler and standpipe risers in stairwells was estimated from the level of damage to surrounding structural and wall board enclosures. Table 3–7 provides stairwell damage estimates from the NIST best estimate analysis.

Table 3–7. Damage estimates to WTC 1 from aircraft impact.

Floor	Stairwell Damage (Stairwell Position Relative to Core)		
	A (1) (Northeast Quadrant)	C (2) (Northwest Quadrant)	B (3) (Southeast Quadrant)
94	Wallboard Destroyed	Structural Damage	Wallboard Destroyed
95	Wallboard Destroyed	Structural Damage	Wallboard Destroyed
96	Wallboard Destroyed	Wallboard Destroyed	Wallboard Destroyed
97	Wallboard Intact	Wallboard Destroyed	Wallboard Intact

Assuming that all risers were lost in stairwells suffering damage to adjacent structural members (Structural Damage) or debris damage to the stairwell enclosure (Wallboard Destroyed) the following effects were likely to have occurred:

- Loss of standpipe riser FS-F1.
- Loss of standpipe riser FS-F2.
- Possible loss of standpipe riser FS-F3.
- Loss of standpipe system water supply after a limited amount of time as a result of the damage to the standpipe risers.
- Loss of sprinkler systems on the 94th through 96th floors.
- The effectiveness of the sprinkler systems in the high and mid level zones was reduced, however, the systems were capable of containing small fires on multiple floors.
- Possible loss of the sprinkler systems on other floors immediately above the 96th floor and below the 94th floor.
- Loss of sprinkler system water supply after a limited amount of time as a result of the damage to the standpipe risers.

It is not likely that the WTC 1 aircraft strike damaged the sprinkler and standpipe systems and associated water supplies in WTC 2 or WTC 7. Therefore, it is likely that these systems remained intact and operational.

Assuming the damage listed above, it would have been physically possible to partially restore the fire protection systems in WTC 1. The standpipe risers contained isolation valves on the 88th and 99th floors. The standpipe reserve water storage on the 110th floor could have been used to supply water to the hose stations above the 99th floor. The manual fire pumps and FDCs could have been used to supply water to the hose stations below the 88th floor. However, the status of these systems was unknown and communications from above and below the impact zone were sporadic, making it unlikely that partial restoration would have been practical even if the procedure were documented ahead of time.

The initial damage to the sprinkler systems was localized to the 94th through 96th floors. It is possible, but unlikely, that the floor control valves for these systems could have been used to isolate these systems to allow the riser to supply the sprinkler systems on other floors without any reduction in effectiveness. This would have to have been accomplished immediately after the initial impact, before the loss of fire resistive construction required for fire confinement to that part of the building.

The damage to WTC 2 as a result of the aircraft strike was concentrated on floors 78 through 81. Based on best estimate analysis of impact damage (NIST NCSTAR 1-2B), the survival of sprinkler and standpipe risers in stairwells was estimated from the level of damage to surrounding structural and wall board enclosures. Table 3–8 provides stairwell damage estimates from the NIST best estimate analysis.

Table 3–8. Damage estimates to WTC 2 from aircraft impact.

Floor	Stairwell Damage (Position of Stairwell on Floor or in Core)		
	A (1) (Northwest Quadrant)	C (2) (Southwest Quadrant)	B (3) (Northeast Quadrant)
78	Wallboard Intact	Wallboard Intact	Wallboard Destroyed
79	Wallboard Intact	Wallboard Destroyed or Intact	Wallboard Destroyed
80	Wallboard Intact	Wallboard Intact	Wallboard Destroyed
81	Wallboard Intact	Wallboard Intact	Wallboard Intact

Assuming that all risers were lost in stairwells suffering damage to adjacent structural members (Structural Damage) or debris damage to the stairwell enclosure (Wallboard Destroyed) the following effects were likely to have occurred:

- Loss of sprinkler riser B (located in the northeast quadrant).
- Loss of sprinkler and standpipe system water supplies after a limited amount of time as a result of the damage to sprinkler riser B.
- Loss of the sprinkler systems on the 78th through 81st floors.
- Loss of water supply to the sprinkler systems on floors 32 through 78.
- The effectiveness of the sprinkler systems above the 79th floor was significantly reduced as a result of the loss of riser B.

- Possible loss of the sprinkler systems on other floors immediately above the 96th floor and below the 94th floor.

Loss of the standpipe system risers was not foreseen, and manual fire pumps and FDCs were still likely to have been operable. No information was found that indicated that the sprinkler and standpipe systems and associated water supplies in WTC 7 were damaged as a result of the WTC 2 aircraft strike. It is also unlikely that further damage to the sprinkler and standpipe systems in WTC 1 occurred as a result of the WTC 2 aircraft strike.

The collapse of WTC 2 likely impacted the fire protection systems in WTC 1 as a result of the damage incurred to the sub-grade sprinkler and standpipe loops and damage caused by vibration and pressure waves. It is also likely that the collapse of WTC 2 damaged the NYC water distribution system near WTC 2. The configuration of the system would have minimized any impact to the fire protection systems in WTC 1 and WTC 7.

It is likely that the collapse of WTC 1 caused significant damage to the water distribution system. It was reported that burning debris caused fires in WTC 7 as a result of the collapse of WTC 1. However, no evidence was found that the integrity of the sprinkler and standpipe riser systems was affected. No fire department actions were taken to suppress fires in WTC 7 once the building was evacuated. An eyewitness account indicated that at some point there was no water to the standpipes. The cause of this is unknown, but could have resulted from a loss of power to the fire pumps, diversion of the water from the standpipes for other fire department operations, and/or the inability of the fire department to supplement the water supply to WTC 7 using the FDCs. A decision was made to not initiate fire fighting activities in WTC 7. It was reported that hose lines connected to the standpipe system in WTC 7 were used to fight fires in other buildings of the WTC complex prior to the collapse of any of the buildings. WTC 7 stood for nearly seven hours after WTC 1 collapsed before succumbing to the fire. The actual effectiveness of the sprinkler systems in WTC 7 would have degraded considerably over that period of time. If the city water supply to the building was interrupted, the sprinkler systems on the lower 20 floors would not have had adequate water to operate properly.

3.11 SUMMARY OF FINDINGS

The following list summarizes the key findings from the review of the building designs and analysis of the water supplies, sprinklers, and standpipe systems:

- In general, the water supplies, automatic sprinklers, and standpipe/pre-connected hose systems in WTC 1, 2, and 7 were determined to be robust, and exceeded the minimum applicable code requirements as well as associated engineering best practices.
- Except for specific areas that were exempted from required sprinkler coverage, sprinkler systems for fire control were installed throughout WTC 1, 2, and 7. Such systems are expected to “control” fires until the fire department can initiate suppression operations and extinguish the fire.
- The water supplies for WTC 1 and WTC 2 and floors 21 through 47 of WTC 7 included large capacity storage tanks and direct connections to the NYC water distribution system. These supplies provided redundant sources of water for the standpipe and sprinkler system

infrastructures. The storage tanks provided adequate duration of supply for normally expected fire exposures to allow the fire department to respond and supplement the demand.

- The lower floors (1 through 20) in WTC 7 were supplied directly from the NYC water distribution system through two service lines from the street main on Washington Street. An automatic fire pump was used to supply the water to the combined sprinkler and standpipe risers. The water supply tanks located in the upper part of the building did not service the lower floors. A manual fire pump and secondary connection to the NYC water system were provided for the lower floors rather than using water supply tanks. Therefore, there wasn't a secondary source of water in the event the NYC system became inoperable.
- The installation of the supply piping from the storage tanks on the 110th floor in WTC 1 and WTC 2 resulted in restricted flow capacity to several floors in the mid-level water supply zones in both buildings. While the flow capacity was sufficient to supply the sprinkler and standpipe systems, the installation was not consistent with engineering best practices.
- The suppression systems in WTC 1, 2, and 7 required manual operation of fire pumps in order to provide secondary water. An automatic supplemental water supply has been required by NFPA 14 for some time and represents best practice. Due to extensive damage to the sprinkler and standpipe systems in WTC 1 and WTC 2 on September 11, 2001, it is doubtful that automatic pumps would have made any difference in performance.
- The supply risers and related infrastructure for the automatic sprinkler systems in WTC 1, 2, and 7 were configured to provide redundant capabilities. However, the typical floor level sprinkler system was installed with one connection to the infrastructure riser, providing a single point of failure of the water supply to the floor level sprinklers.
- Based upon the documents examined, the sprinkler systems met or exceeded the applicable installation requirements in the BCNYC and NFPA 13. There were several design features that were considered inconsistent with engineering best practices, but no evidence was found to indicate that these features affected the events that occurred on September 11, 2001.
- The sprinkler systems installed in WTC 1, 2, and 7 were robust, with calculated water spray densities considerably greater than typically provided for high-rise office buildings. Based on historical incident data, systems having such characteristics would be expected to extinguish, in addition to control, most fires that occur in these types of buildings.
- Based on hydraulic analyses it was estimated that the sprinkler systems could have provided fire control at coverage areas up to two or three times the specified design area of 1,500 ft². However, while this capability would be considered very robust, a coverage area of 3,000 to 4,500 ft² constituted less than 15 percent of the floor area of a single floor in these buildings. Estimates of the intensity and extent of the initial fires in WTC 1 and WTC 2 on September 11, 2001, were considerably greater than two to three times the specified design areas, and involved multiple floors. While there was no way to confirm the extent of the initial fires, it is likely that a large number of sprinklers would have been opened on multiple floors. Additionally, the aircraft impact damaged the sprinkler system infrastructure, reducing effectiveness. Once the number of open sprinklers or the extent of system damage

area exceeded an area equivalent to two or three times the design areas the system's ability to control the fire would have been reduced, and the duration of the primary water supply would have rapidly degraded.

- The standpipe preconnected hose system installations were consistent with the applicable requirements in the BCNYC. They were not consistent with the flow rates and durations required in NFPA 14.
- No information was found that indicated that the generator/fuel day-tank enclosures in WTC 7 were protected by automatic sprinklers or other special hazards protection.
- Primary and backup power was provided in all three buildings, but the absence of remote redundancy of the power transmission lines to emergency fire pumps could have affected the operability of the sprinkler and standpipe systems once power was lost.
- The roles of the special fire suppression systems that were installed in WTC 1, 2, and 7 on September 11, 2001, could not be determined due to the absence of any information regarding their performance.
- Due to the magnitude of the initial fires and the likely damage sustained to the suppression systems infrastructures in WTC 1 and WTC 2, it is not unexpected that the suppression systems present in these buildings failed to control the fires on September 11, 2001. Although the installed sprinkler systems were determined to be more robust than typical, the initial sizes of the fires likely overwhelmed the sprinkler systems, and even if the systems had been designed to protect much higher hazard levels (i.e., Ordinary Group II or Extra Hazard), the magnitude of these fires would have resulted in the fires not being controlled.

Chapter 4

FIRE ALARM SYSTEMS

The purpose of a building fire alarm system is to detect fires, notify occupants, summon emergency responders, and provide information to help manage the response. The applicable local building and fire codes establish basic requirements for the fire alarm system. The fire alarm system layout and interaction with other building systems are established by the designers as part of the fire protection plan for a facility. For World Trade Center (WTC) 1, 2, and 7, the primary monitoring and control of the fire alarm system was performed from the Fire Command Station (FCS) within each building. This station and its redundant sites received signals from fire detection devices installed throughout the towers. In response to this automatic fire detection, voice announcements or tone notification could be sent to selected floors or throughout the entire building. The FCS provided means for two-way telephone communications for fire fighters, floor fire wardens, and operators in the mechanical and air handling control rooms. The Fire Department of the City of New York (FDNY) could be notified manually from the FCS. Upon arrival, fire fighters commanded the response from the FCS, using the information and communications provided to understand conditions in the building and aid in the response.

The design and installation of the fire alarm systems in WTC 1, 2, and 7, including the capabilities for emergency communications, have been documented in National Institute of Standards and Technology (NIST) NCSTAR 1-4C prepared for NIST by subject experts at Rolf Jensen & Associates, Inc. Based on information collected in the investigation and early damage estimates for WTC 1 and WTC 2, the performance capabilities of the systems on September 11, 2001, were estimated. Statements from survivors, video, and voice recordings available later in the investigation were used to assess and improve earlier predictions.

All resources used by the subject experts in the investigation of the fire alarm systems in WTC 1, 2, and 7 are documented in NIST NCSTAR 1-4C. In addition, the fire alarm record for WTC 7 was obtained from AFA Protective Systems, Inc. AFA Protective Systems, Inc provided central station monitoring services for the fire alarm system from an off-site location.

Even though the on-site documentation for the fire alarm systems in WTC 1, 2, and 7 were lost, the investigation gathered documents from alternate sources to help piece together the specifications, design, installation, and maintenance of these systems. Much more information was available to the investigation for WTC 1 and WTC 2 than for WTC 7. In particular, information about the replacement of the WTC 1 and WTC 2 fire alarm systems installed after the bombing in 1993 was valuable in this investigation.

4.1 WTC 1 AND WTC 2 FIRE ALARM SYSTEMS

4.1.1 History

The fire alarm system protecting WTC 1 and WTC 2 on September 11, 2001, was a total replacement for the original system that was damaged by the bombing on February 26, 1993. Details about the originally installed fire alarm system are provided in NIST NCSTAR 1-4C. The bomb that exploded on the

B-2 level of the underground parking garage totally destroyed the original WTC 1 and WTC 2 fire alarm signaling and communication wiring entering the Operations Control Center (OCC) on the B-1 level. That event effectively made the fire alarm system at the time nonfunctional. Although electricians restored the operability of the fire alarm, public address, and manual station system within two weeks, The Port Authority of New York and New Jersey (PANYNJ or Port Authority) questioned the WTC's existing fire alarm system's capability to provide reliable life safety support functions. In particular, the existing system, which was developed and supplied exclusively for the WTC by the American Multiple System Company, was no longer manufactured, and the software was not supported. In addition, the 1993 bombing proved the system infrastructure to be vulnerable to a single point of failure. Based upon the inability to obtain spare parts, lack of system support, and the vulnerability of the system, on March 17, 1993, the Port Authority authorized the purchase of a new, state-of-the-art addressable fire alarm system for the WTC complex (including buildings 1, 2, 4, and 5, which were also monitored by the OCC) (PANYNJ 1993). New fire alarm drawings were developed for WTC 1, 2, 4, and 5, which were issued for bid on March 25, 1993. On April 5, 1993, the fire alarm installation project was awarded for construction. On March 26, 1997, PANYNJ issued another purchase order for fire alarm equipment to complete the fire alarm project.

The replacement fire alarm system supported a decentralized infrastructure that consisted of six independent fire alarm systems protecting WTC 1, WTC 2, WTC 4, WTC 5, Concourse Level, and the Sub-Grade Levels. The four buildings had a master monitoring and control Network Command Center (NCC) located at the building's FCS. Building 4 was also provided with a redundant remote NCC that monitored Building 5, and Building 5 was provided with a redundant remote that monitored Building 4. The Concourse and Sub-Grade master NCCs were installed in WTC 2, and remote NCCs for the Concourse and Sub-Grade were installed in WTC 1 along with a remote NCC for WTC 2. A redundant remote NCC for monitoring and control of all six systems was installed in the Operations Command Center.

The installation of the WTC 1 and WTC 2 fire detection and alarm systems was separated into three phases to address the constructability of the new systems, while enhancing fire protection capabilities in the quickest manner possible and to ensure fire protection continuity during the switchover to the new fire alarm system. Phase I installed the backbone of the new system, including the master fire alarm panel, remote panels, cabinets on each floor for wiring the new system, and interface modules to provide monitoring and control functions between the old and the new systems during transition. In Phase II, both the new and old systems operated concurrently while making the transition of monitoring and control from the old to the new system. New core area speakers, warden phones, and pull stations were connected to the new fire alarm system. Phase III included the replacement of all existing fire detection devices and expanding the new speaker and strobe capabilities into all tenant and mechanical spaces.

The installation of a new fire alarm system, while maintaining protection for WTC 1 and WTC 2, was an enormous undertaking, requiring years to complete. On September 11, 2001, the replacement of some original system components was still underway. On September 11, 2001, the new installations in WTC 1 and WTC 2 were 85 percent and 80 percent complete, respectively (PACO 2002). The same source estimated that 25 percent of the old fire alarm system was still in use at the time of the attack.

Even though some parts of the original fire alarm system were still operational in WTC 1 and WTC 2, no documentation was found that identified what parts or what areas were protected by the old system. Even

though some parts of the system were operating with old system hardware, the entire fire alarm system was managed through the new fire alarm control and monitoring equipment.

4.1.2 Building and Fire Prevention Codes

The WTC was designed in accordance with the New York City Building and Fire Prevention Codes of 1968 in effect at the time of the building's construction. The PANYNJ's objective was to adhere to or exceed local code requirements whenever practical.

During the life of the buildings, in addition to legislated building codes, the PANYNJ relied on nationally recognized fire safety standards published by the American National Standards Institute (ANSI) and the National Fire Protection Association (NFPA), as well as internal protocols established with fire officials in the city. Two noteworthy protocols included the "Protocol for Periodic Joint Port Authority/ Fire Department of New York Inspections of Port Authority New York City Facilities" of 1988 and the "WTC/ FDNY Joint Protocol for Inspectional Activity at the World Trade Center Complex" of 1986. The PANYNJ maintained a positive working relationship with the FDNY through these protocols that allowed the Fire Department access for inspections and evaluation of life safety and fire protection systems at the complex. The Fire Department was provided with the authority to issue advisory reports resulting from their inspections, which the PANYNJ could consider on a voluntary basis.

This spirit of cooperation also existed with the New York City Department of Buildings and formally acknowledged in a Memorandum of Understanding between the two parties after the explosion at the Towers on November 3, 1993. The most current edition of the New York City Building Code was identified as the design basis for any construction after November 1993.

The applicable building codes document the minimum acceptable level of safety for occupants. The building codes in effect are the primary source for determining what safety features will be installed in the building. The building code includes referenced standards that address how various aspects of the building and systems are to be installed and constructed in order to provide the intended levels of safety. Another regulatory element that comes into play is product safety standards. Building codes and installation standards require the use of products that have been investigated to verify that they perform as intended without causing a safety hazard. Product safety standards and listing agencies provide vehicles for evaluating the performance of products from a safety perspective. Verification and testing of products for public safety ensure that the level of safety established by the building codes for the building design, and implemented per recognized installation standards during the building's construction, will be accomplished through the products' performance.

4.1.3 FCS and Alarm System Installation and Functions

The overall performance of the fire alarm system is dependent on the installation of the equipment and devices meeting prescribed standards. Installation standards originate from the manufacturer, design criteria, and local requirements. The major equipment installation requirements for the WTC as they related to equipment performance included:

- speakers located to ensure their operation would be heard clearly above ambient noise level

- the voice loudspeaker system required to ensure 50 percent of the system remains operable throughout the building in the event 50 percent became inoperable
- visual alarm devices in common use spaces
- automatic smoke detectors in the mechanical rooms, electrical switchgear rooms, electric and telephone closets
- automatic smoke detectors installed at the return air ducts serving each floor required to shut down corresponding air handling unit upon the detector's activation
- automatic smoke detectors at each elevator landing for recalling elevators upon detector activation
- at least one manual fire alarm station installed in each story in the path of escape -- No point on a floor could be more than 200 ft from the nearest station.
- floor warden telephone stations located between required stairways
- standpipe telephones near the main standpipe in the stairway on each floor, and within the sprinkler water tank and fire pump rooms
- FCS located in the lobby of the building
- the fire alarm wire with a minimum size, and type that would not support flame
- a terminal connection box for the wiring serving a maximum of five floors above and five floors below the terminal box
- riser cable and its branches not required to be installed in conduits or raceways if not exposed to public view

The fire alarm system within the WTC offered multiple functions to enhance the overall life safety features within the buildings. The primary monitoring and control of the fire alarm system was performed at the FCS within each building. The life safety functions performed by the FCSs were:

- an audible alarm signal upon an alarm condition or system malfunction
- manual control of the emergency voice and alarm communication capability—voice or alarm notification could be selected by the individual floor, group of floors, or throughout the complete building
- a means to silence the audible alarm signals when the loud speakers were in use and for activating the audible alarm system automatically when use of the loud speakers was terminated
- manual acknowledgment of the alarm or system fault condition through an alpha/numeric display and keyboard

- a two-way telephone system for the firefighters with the capability to make announcements over the emergency voice and alarm communication system
- a two-way telephone system for the floor warden stations, mechanical control center, and air-handling control rooms
- a means to manually transmit a fire alarm signal to the fire department
- means for testing the display, alarms, and connection to the fire department

The detection and notification functions were performed throughout the building by the fire alarm system. The life safety functions performed by the fire alarm system were:

- emergency voice and alarm speakers for audible notification and communication in all areas within the building
- strobes to provide visual alarm indications for the hearing impaired
- two-way standpipe telephone communication system
- two-way Floor Warden telephone communication system
- two-way Maintenance telephone communication located at the remote fire alarm panel locations
- automatic smoke detection that would provide an alarm signal at the FCS upon activation
- monitor the fire sprinkler system for water flow or disabled performance conditions that would alarm at the FCS upon activation
- manual stations for occupant activation that would alarm at the FCS upon activation
- monitoring of independent fire alarm systems installed by individual tenants that would annunciate their alarm condition at the FCS
- automatic notification of the fire department upon fire alarm activation

4.1.4 Fire Alarm System Design

The magnitude of the fire alarm system for the WTC towers was reflective of the protected building's size and the large number of people that occupied the building on any given day. To control a project of this size, specific design criteria were developed based upon the system's performance objectives and fire protection goals. The design criteria designated type, models, location, and performance of the fire alarm control and monitoring equipment, supporting hardware, and fire alarm devices. Procedures were also developed to monitor and track the project's progress. The phased project approach and its criteria allowed the original system's fundamental monitoring, controls, and communication capabilities to be transferred to the replacement system during the first phase of the project, and allowed new or revised fire alarm devices to be put into service as soon as they were functional during succeeding phases.

The WTC 1 and WTC 2 fire alarm system consisted of multiple control panels of various capabilities distributed within each tower and interconnected for redundancy. The distributed panels shared intelligence, information, and control through a system of signal communication paths. The system also provided the capability and controls for emergency communication of voice messages within the buildings. Figure 4–1 shows several alarm and control panels at the lobby FCS in WTC 1. Details of the installed equipment and function are provided in NIST NCSTAR 1-4C.

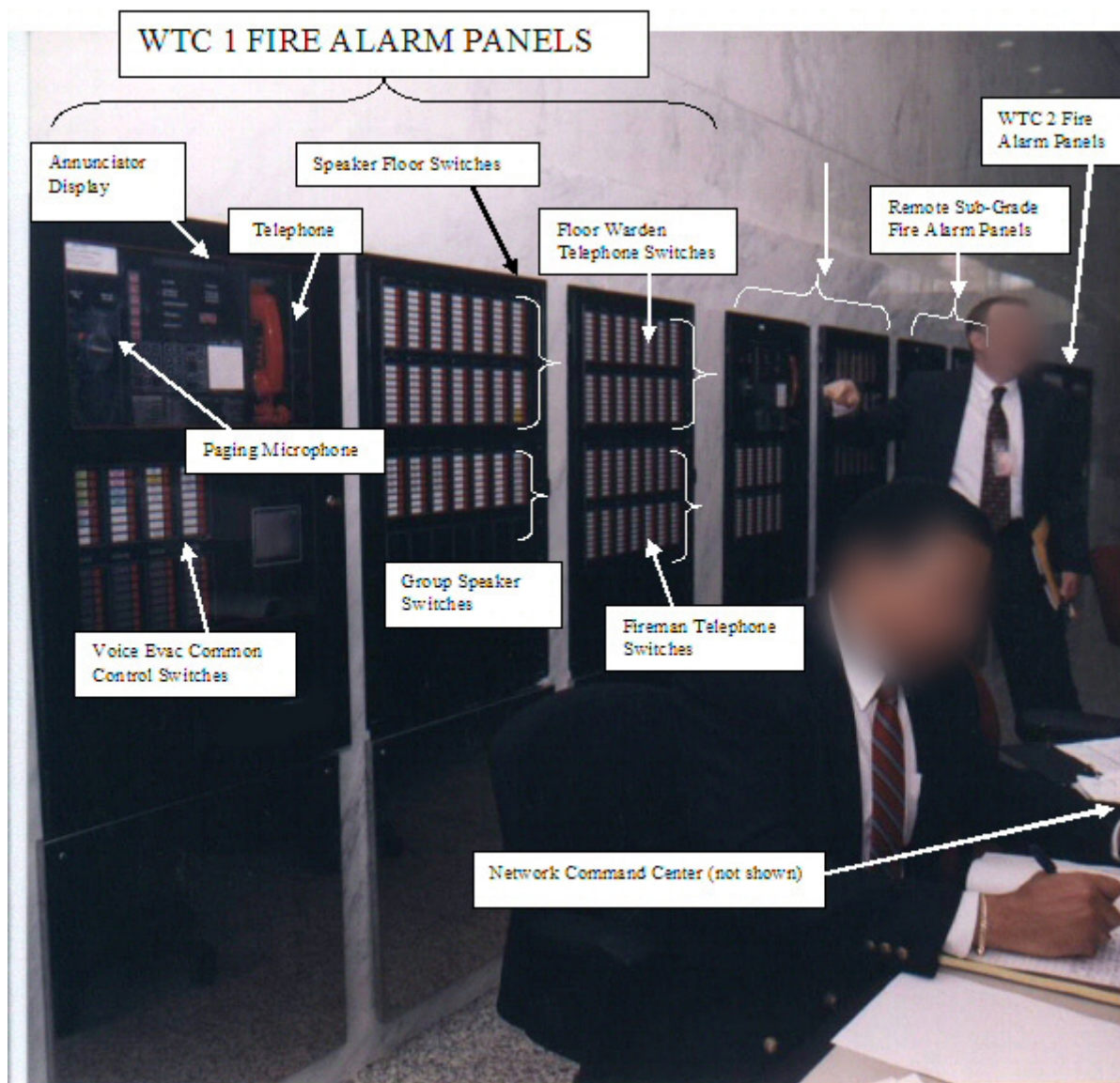

Source: Reproduced with permission of The Port Authority of New York and New Jersey.

Figure 4–1. WTC 1 FCS with functions of the alarm and control panels labeled.

A standardized approach for the design and installation of WTC 1 and WTC 2 fire alarm equipment and devices was developed by subdividing a typical floor plate into a core and quadrants (See Fig. 4–2.). The intent was to set quality control standards with typical requirements and locations for common equipment, devices, and circuits within an assigned area.

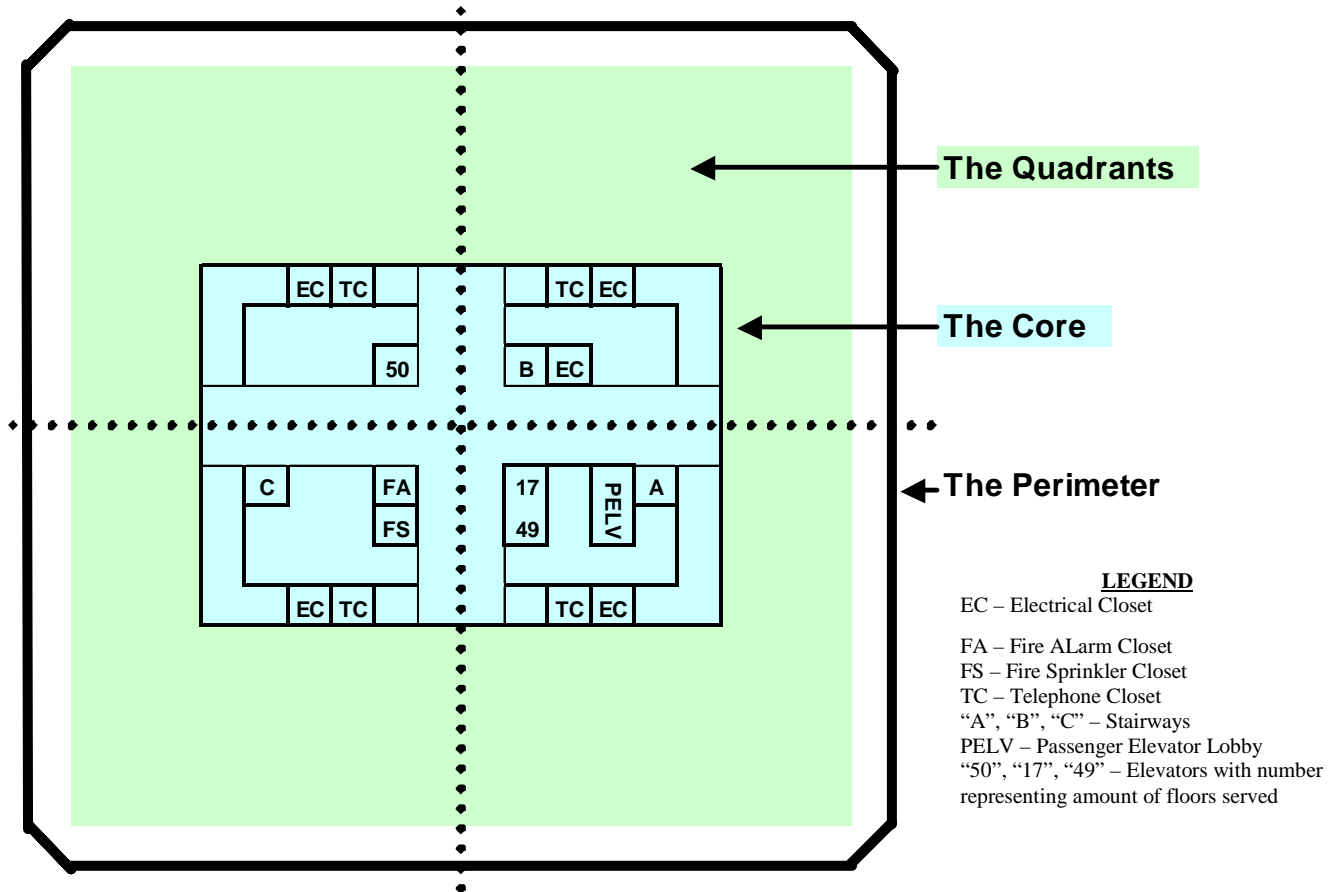

Source: Drucker 2001a, 2001b.

Figure 4–2. Typical WTC 1 and WTC 2 core and quadrants.

Specific areas within the typical floor template were designated for the fire alarm control equipment, initiating devices, and communication equipment, as shown in Fig. 4–3. Drawings were developed to provide a submittal format for architects, engineers, and contractors. The drawings provided a guideline for the design and installation of the fire alarm equipment and devices. The intent was to set a standard on what information was required for approval and what was required from the installation contractor to ensure the performance and survivability requirements for the system.

The fire alarm system chosen for WTC 1 and WTC 2 was the Ceberus Pyrotronics MXL-V, and a backbone was developed and designated as the “Base Building Fire Alarm System” (BBFAS). The BBFAS provided the basic support structure and interface components for the fire alarm system throughout each building. An improved network configuration was developed for the system that enhanced survivability and overall signal processing time through the introduction of a distributed intelligence network.

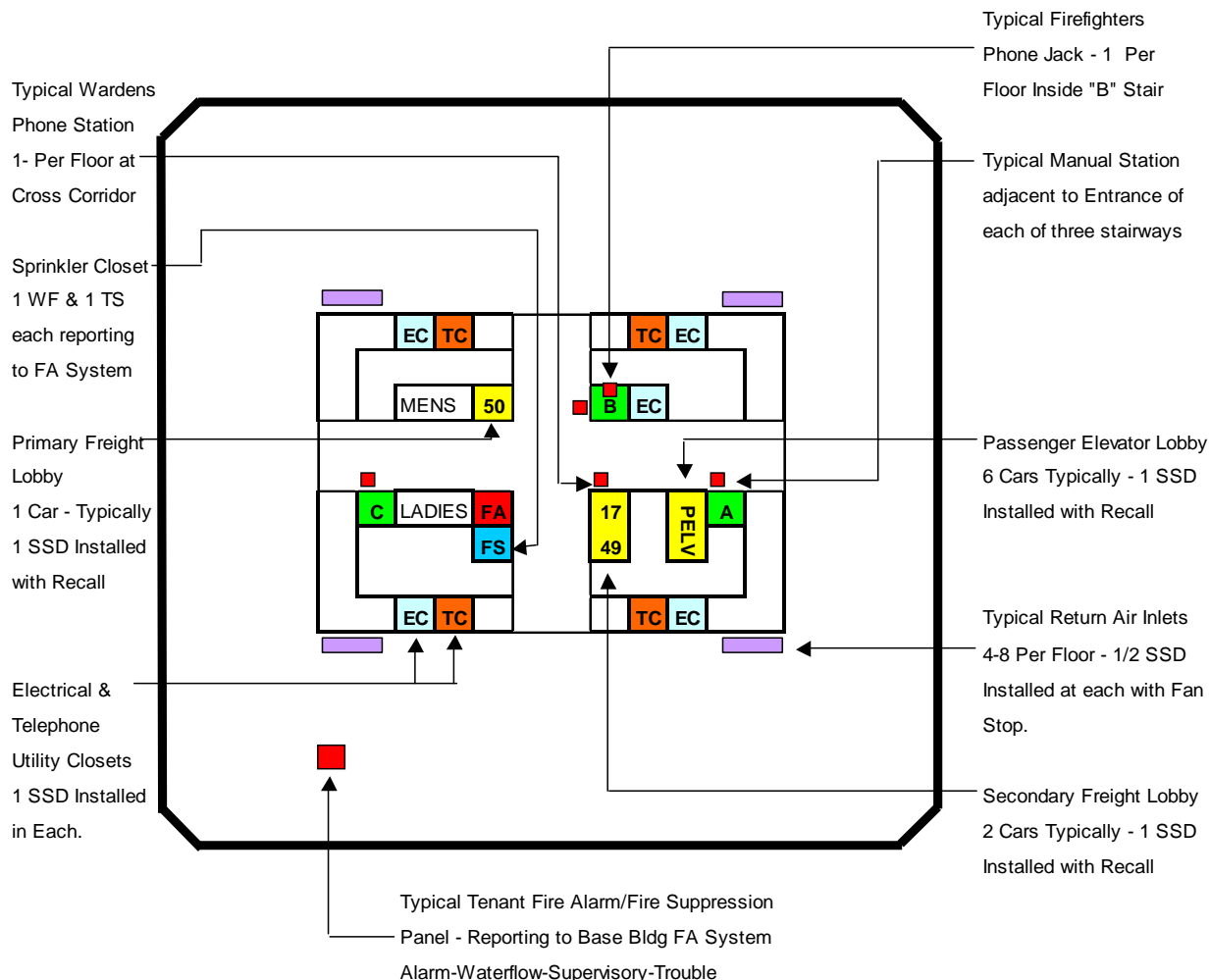

Source: Drucker 2001a, 2001b.

Figure 4–3. Standard fire alarm equipment and device locations.

The final system architecture consisted of the main head-end MXL-V fire alarm panel located at the FCS; distributed MXL-VR remote control panels which were located within both Towers on levels B6, 7, 41, 75, and 108; and Power Supply Remote (PSR) slave panels that were monitored and controlled by the remote panels. The remote panels provided localized intelligence and acted as the master over the slave panels. Each remote panel would monitor and control up to eight slave panels, which were located every third floor (typically) and contained system transponders, amplifiers, terminal cabinets, and interface points that provided access to the BBFAS platform. Each slave panel would provide the central monitoring and control point for fire alarm cabinets located on each floor.

The interconnection of the distributed panels within each tower was accomplished through multiple vertical system network transmission paths commonly referred to as risers. A fire alarm riser may contain

numerous transmission paths for multiple functions associated with the system. The WTC 1 and WTC 2 system risers controlled functional capabilities that included:

- Fire detection
- Life safety system monitoring
- Life safety system control
- Occupant notification
- Floor warden and firefighter telephone communication capability
- System display and control of the fire alarm system

The risers within the buildings contained four types of communication paths that performed separate fire alarm functions. One of the communication paths connected the head-end fire alarm panel to all of the remote panels. The second and third communication paths connected the head-end panel to the slave panels. The fourth communication path connected the separate remote panels to their slave panels.

The single communication path from the head-end panel to the remote panels consisted of a Signaling Line Circuit, referred to by the manufacturer's term XNET (Fig. 4-4). The XNET provided a global communication path for the head-end fire alarm system in the FCS and OCC to monitor the fire alarm detection and supervisory devices and control the interfaced fire alarm and life safety systems connected to the remote and slave systems. The two separate communication paths from the head-end panel to the slave panels consisted of a Notification Appliance Circuit (Fig. 4-5), which provided the alarm signal and voice messages for the buildings loudspeakers and the Warden/Standpipe telephone circuit (Fig. 4-6). The fourth communication path originated from and was connected to its remote fire alarm panels. The path was a separate Signaling Line Circuit, referred to by the manufacturer's term MNET (Fig. 4-7). The MNET was a local communication path that was dedicated to each remote fire alarm panel and its slave panels. The MNET provided a local communication path to monitor the slave systems' fire alarm detection and supervisory devices and control the interfaced fire alarm and life safety systems connected to the slave systems.

The XNET and MNET design and installation provided enhanced network integrity and reliability through a loop wiring topology configuration that provided separate network communication path risers (primary and secondary) installed in three different locations (fire alarm closet and stairways "A" and "C").

The final circuit was the warden/standpipe telephone system. The single pair of telephone wires did not have the enhanced survivability characteristics associated with the Class A, Style 7 Signaling Line Circuit or Class A, Style Z Notification Appliance Circuit. The telephone circuit performance allowed a single open (cut wire) or wire-to-wire short to disrupt service between the head-end panel and beyond where the wire fault occurred. The variability in performance of the fire alarm systems after impact can be attributed to the disparity of performance between the different types of circuits.

The communication path risers were separated into three locations to enhance survivability, as seen in Figs. 4–8 and 4–9. The PANYNJ’s intent was to limit degradation of the fire alarm system’s performance if a riser was damaged. The incorporation of multiple risers was in response to the 1993 bombing, where the blast disabled all fire alarm functions within WTC 1 and WTC 2 when the single fire alarm riser was severed.

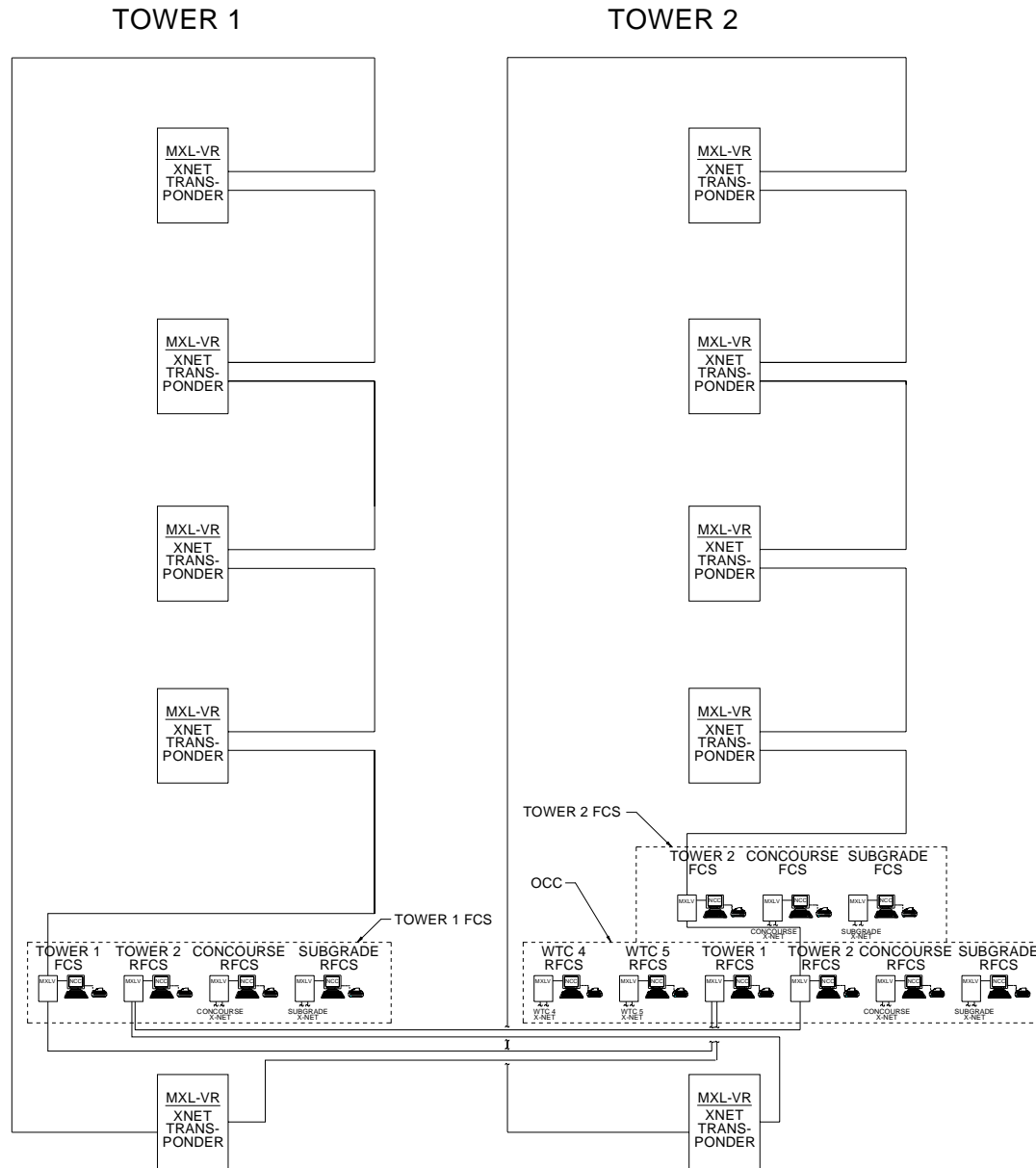

Figure 4–4. XNET network configuration single-line schematic.

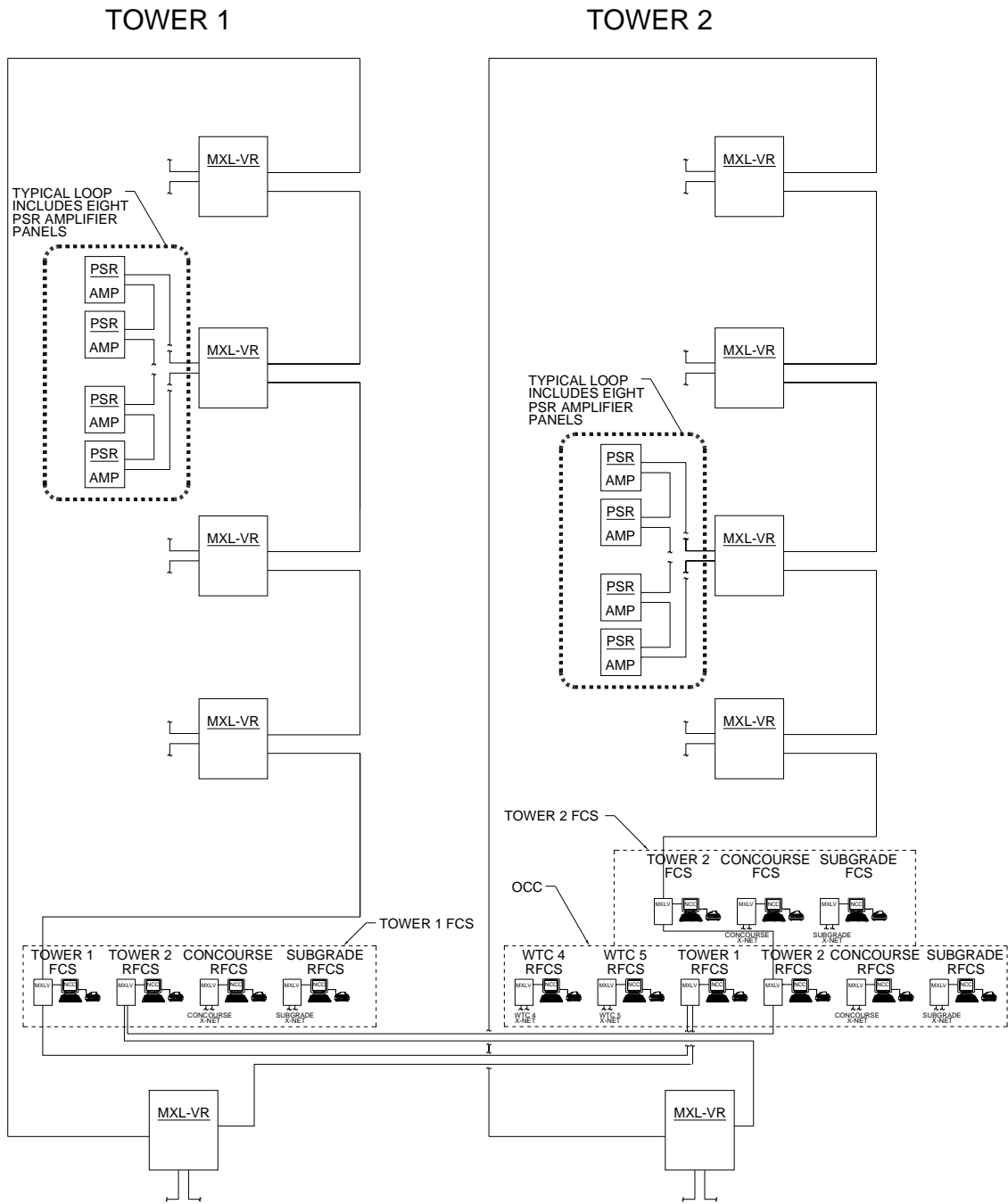

Figure 4-5. Notification appliance network single-line schematic.

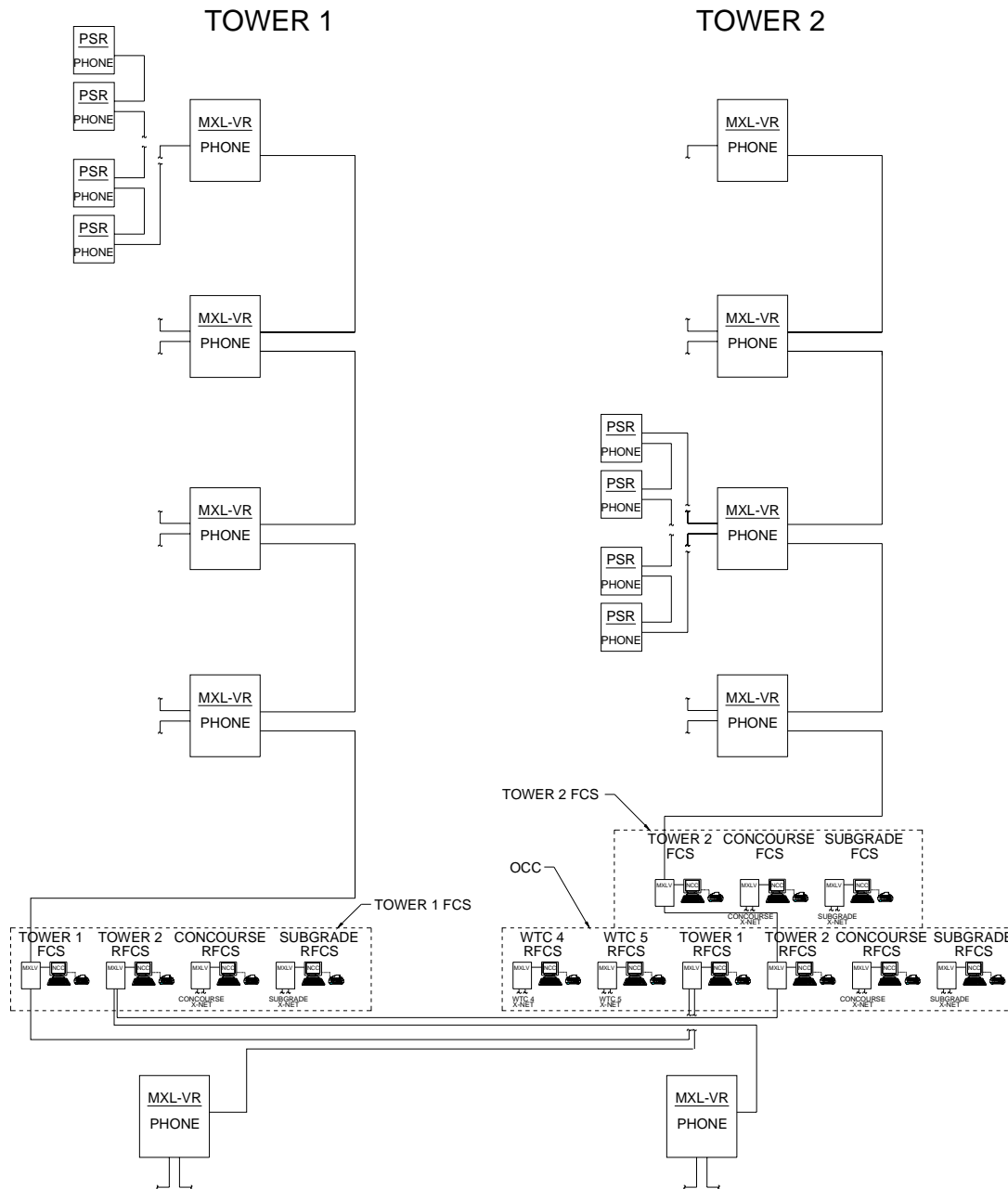

Figure 4-6. Floor warden and firefighter telephone single-line schematic.

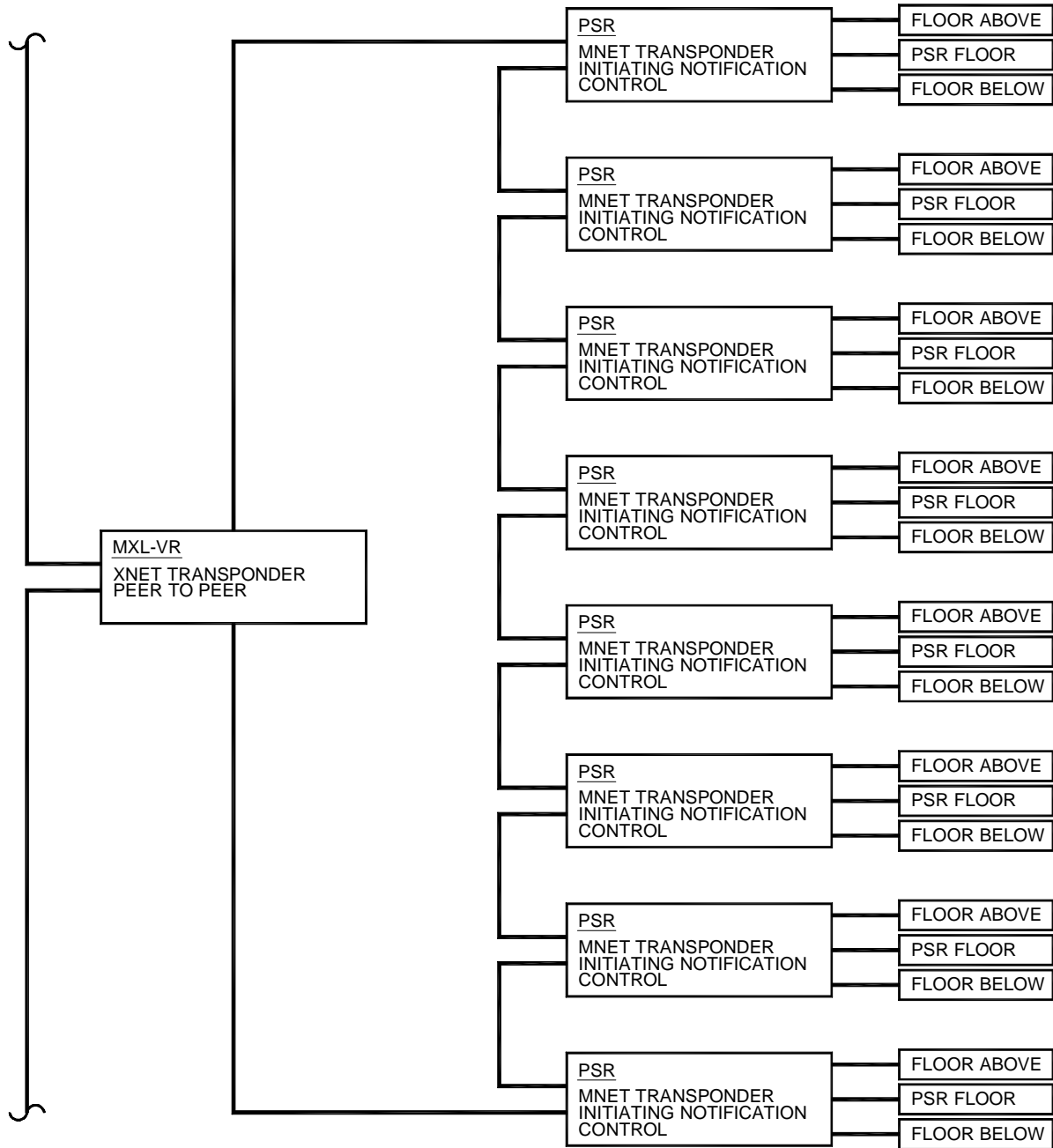

Figure 4-7. MNET network configuration single-line schematic.

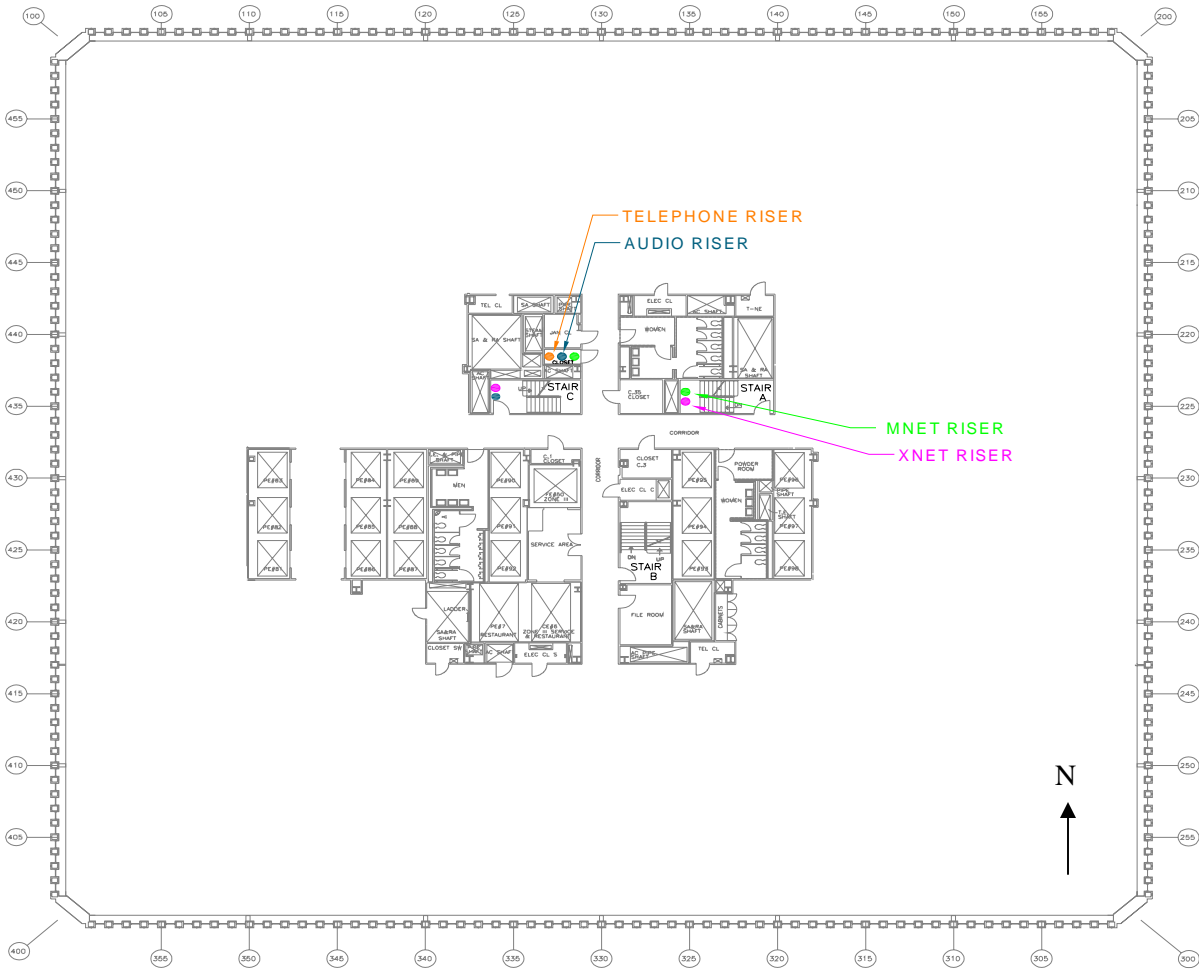

Figure 4–8. Typical WTC 1 riser locations on impact floors.

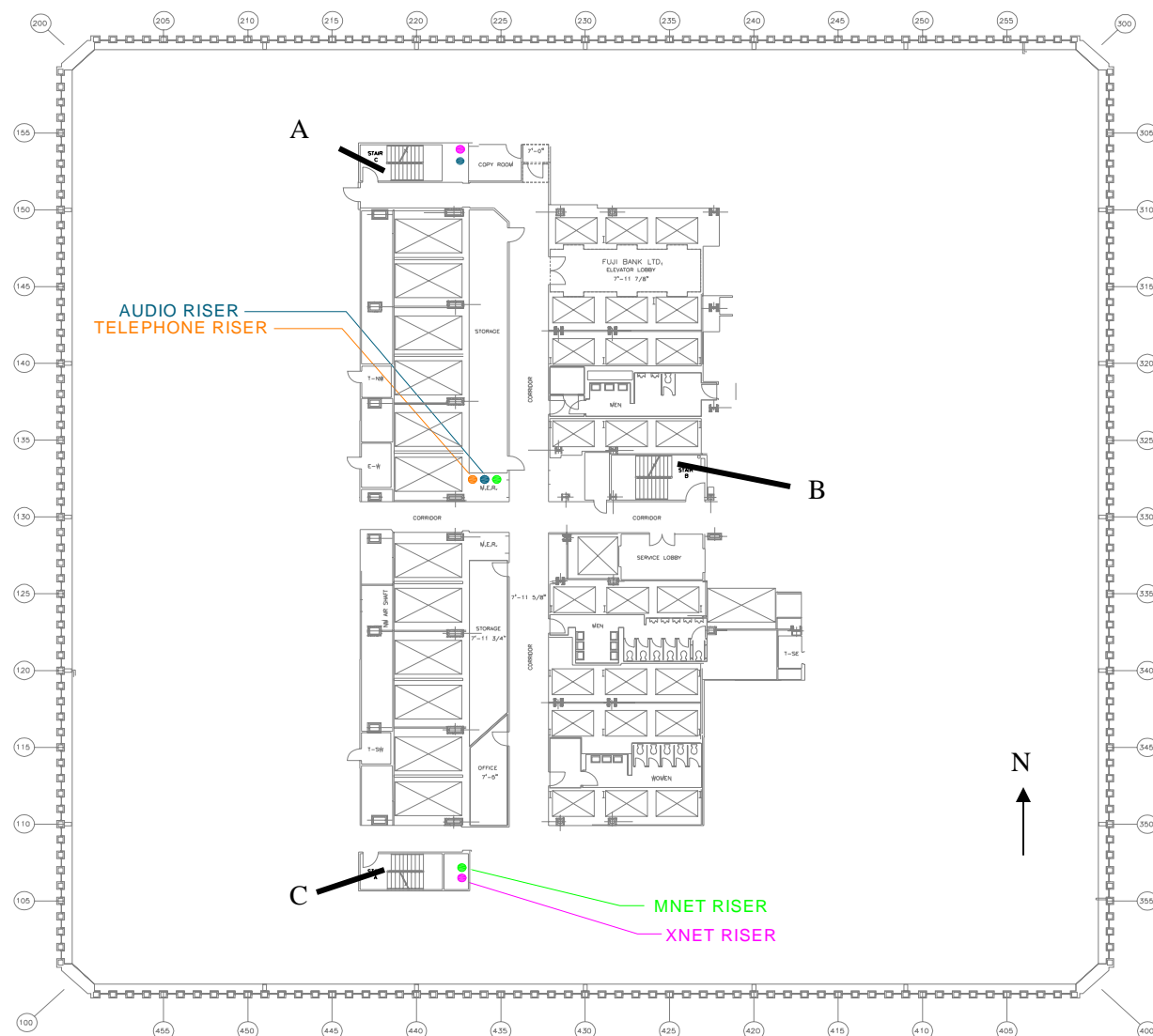

Figure 4–9. Typical WTC 2 riser locations on impact floors.

4.2 WTC 7 FIRE ALARM SYSTEM

4.2.1 History

WTC 7 was built in 1985 across Vesey Street from the main WTC compound. It was a steel building with forty-seven stories, built above a Consolidated Edison substation. WTC 7 collapsed following a long burning fire, seven hours after WTC 1 collapsed.

The fire alarm system for WTC 7 was the original system installed during the initial construction. Modifications were performed as needed to accommodate renovations and tenant fit-outs. Project development documentation found and analyzed was limited in this investigation to design criteria, specifications, riser diagrams, and a limited number of tenant fit-out drawings that included fire alarm work.

The Basic Design Criteria, labeled as Revised November 5, 1984, was prepared by Syska & Hennessy, and it referenced the applicable local building codes at the time of construction. The only performance criteria in the design that exceeded the minimum requirements of the applicable codes was the statement requiring that “All monitoring, communication and control for the fire alarm system shall be on a separate multiplex channel with its own processor” (Syska & Hennessy 1984).

Fire alarm system specifications dated October 24, 1984, prepared by Tishman Construction Corporation of New York, were reviewed. The specifications provided additional information about the performance requirements of the fire alarm system and provided criteria for its installation.

Based on the information reviewed, the overall design and installation met the applicable code requirements, and inspection, testing and maintenance of the fire alarm system for WTC 7 was provided on a regular basis.

4.2.2 System Arrangement

The baseline for defining the fire alarm system’s performance is derived from the specifications, which referred to the applicable local building codes. The basic system was required to contain the following components to monitor and annunciate the status of its devices and initiate an appropriate response:

- FCS located in the lobby of the building on the entrance floor
- remote alarm display panels in the Mechanical Control Center and Fire Safety Director’s location
- manual fire alarm stations provided in each story along the path of escape with additional stations installed so that the maximum travel distance between stations would not exceed 200 ft
- speakers located on all floors and stairways that can be operated in the FCS—the elevator intercommunication system was provided separately
- visual alarm devices (strobes) in public common use areas
- floor warden stations on each floor that provided two-way communication with the FCS
- standpipe firefighter telephone system with communication stations provided at FCS, each floor near the standpipe riser, gravity tank rooms, and fire pump rooms
- fire sprinkler water flow alarm and malfunction monitoring
- tenant fire alarm panels monitoring for alarm and system fault conditions
- fan shutdown and restart system for smoke control
- elevator recall upon its smoke detector activation

- fire stair door releases
- smoke and heat detection

4.2.3 System Architecture and Operation

The fire alarm system chosen for WTC 7 was the Firecom 8500. The main user interface was at the Fire Command Station, where the head-end fire alarm panel provided central monitoring and control through a monitor with keyboard, illuminated displays, microphone, and control switches. The Class B Signaling Line Circuit riser from the head-end panel went to a Terminal Transmission Box (TTB) on each floor, which was the data gathering panel for the detection, notification and control devices for each floor. The TTB provided Class B conventional Initiating Device Circuits and Notification Appliance Circuits for the manual pull stations, smoke detectors, and speakers. The TTB also provided the circuit interfaces to control the door releases and air handling units. Bulk amplification for all loudspeakers associated with the emergency voice alarm communication system was generated from the fifth floor.

The specifications provided a sequence of operation during alarm conditions for the different types of devices found on the fire alarm system.

1. Activation of a manual pull station, smoke detector, heat detector, duct detector, or sprinkler waterflow switch would:
 - a. Automatically sound all loudspeakers on the floor of alarm and the floor above.
 - b. Automatically transmit the fire alarm signal to the fire department via a central monitoring office.
 - c. Unlock the doors in the fire stairs.
 - d. Sound a fire alarm signal and provide location identification at the FCS, Mechanical Control Center, and Fire Safety Director's location.
2. In addition to #1 above, the duct detectors would:
 - a. Stop air supply and air return from the floor of alarm activation by automatically shutting down air supply and return fans serving these floors.
 - b. Open smoke exhaust dampers of smoke shafts on the floor of alarm activation, start associated smoke exhaust fans, and energize fan of stair pressurization system.
3. In addition to #1 above, the elevator lobby detectors and sprinkler water flow switches would cause elevators serving the floor of alarm activation to return non-stop to street floor or to the lowest landing above street floor when the lowest landing of the elevator bank was above street floor. If the lowest landing was the floor of alarm activation, the elevator would return to a landing two floors above.

4.2.4 Design and Installation

Documentation found consisted of modified riser as-built diagrams and floor plans with fire alarm device locations. Comprehensive as-built drawings for the system were not located.

The modified riser diagrams were conceptual in nature and provided the installation contractor with the number of devices to be installed on each floor, type of fire alarm equipment on each floor, and the number and type of wire interconnecting the devices and equipment. The modified riser diagram had areas crossed-off, which was an indication that the area had undergone renovation. Additional renovation drawings provided a section of the riser with its modifications. The final drawings consisted of the partially modified riser diagrams with areas crossed-out, separate drawings containing a revised section of the riser, and floor plans with the locations of the devices on the designated floor.

It appears that the contractor was responsible for determining the final circuit configurations for the devices and equipment based upon the drawings found. Limited information was found on the specific location of the fire alarm control equipment, initiating devices, and communication equipment.

The third floor lobby was designated as the FCS. On a typical floor, manual pull stations were located at each stair entrance, and smoke detectors were provided in electrical/telephone closets and in elevator lobbies. Sprinkler water flow switches and valve supervisory switches in each stairwell were monitored by fire alarm interface devices. Duct smoke detector locations were not identified, but the criteria required detectors to be installed in heating, ventilation and air-conditioning (HVAC) systems over 2,000 cfm. Fire warden stations were typically installed on the north wall outside the elevator lobby.

A mechanical room was located in the core area of each floor. The south wall of the Mechanical Room was the designated location for fire alarm data gathering panels, which supported and distributed the system's monitoring, control, and communication circuits. The initiation device circuits, speaker circuits, and the notification appliance circuits serving that floor were terminated at the terminal cabinet at this location. Documentation was not located that provided a standard for the equipment or device connections.

Drawings were not located that provided guidance on the installation of the fire alarm devices to meet tolerances required by code and the manufacturer. The riser diagrams indicated that the smoke detector, manual pull station, speaker and strobe circuits were configured to be a Class B type. The use of a Class B circuit was consistent with the minimum requirements for performance, but a Class B circuit does not have the higher level of survivability associated with a Class A circuit.

Drawings also were not located showing the number of wires required to run between each device, and between the device and equipment, nor were fire alarm power calculations located that would document the capability of the fire alarm equipment to power the number and type of devices connected to the equipment. No quality control documentation was found for the installation, and no testing and commissioning procedures were located.

4.2.5 Inspection, Testing, and Maintenance

Inspection, testing, and maintenance were mandated by the applicable building codes after a fire alarm system was installed and in operation. The building owner was responsible for inspection, testing, and

maintenance of the systems. The inspection, testing and inspection was permitted to be done by qualified and experienced personnel employed by the owner, or the work could be performed under contract. For WTC 7, the inspection, testing, and maintenance was conducted by a contractor, and, based upon the information reviewed for 2000 and 2001, was adequately documented.

4.3 COMPARISON OF WTC 7 FIRE ALARM SYSTEM TO WTC 1 AND WTC 2 FIRE ALARM SYSTEM

The fire alarm systems installed in WTC 1, 2, and 7 was consistent with the performance criteria as adopted by New York City, but there were significant differences in the approach in meeting these requirements. The development and implementation of the WTC 1 and WTC 2 fire alarm systems was approached in a methodical way to meet specific goals and objectives adopted by the PANYNJ that exceeded the minimum New York City requirements. This was accomplished through the identification of the overall fire alarm goals and the development of systematic steps for system design and installation. In comparison, documents available on the WTC 7 fire alarm system indicated that the design development for the system did not follow the methodical approach used for WTC 1 and WTC 2. The WTC 7 fire alarm design documents consisted of basic working documents used by construction personnel for the equipment layout, which allowed the installation contractor more leeway in determining what materials were used, where devices and equipment were located, and how the system would ultimately perform within the guidelines of the specification. This approach does not indicate that the system design or product was substandard, it only shows that the design, hardware, and equipment layout did not follow the strict development requirements set forth by the PANYNJ for WTC 1 and WTC 2. No documents were found that would indicate that the WTC 7 fire alarm system did not meet the performance standards required for the building.

Additional differences were apparent in the emphasis on survivability as a major goal for the WTC 1 and WTC 2 fire alarm systems, which was not apparent in the WTC 7 system. The survivability enhancements present in the WTC 1 and WTC 2 included distributed fire alarm intelligence, monitoring, and controls on seven different levels. The WTC 7 fire alarm system did not use distributed intelligence and all of the monitoring and control functions resided in the head-end panel on the third floor. Also, the WTC 7 system used bulk amplification with all loudspeaker circuits originating from the fifth floor. Additional WTC 1 and WTC 2 fire alarm survivability enhancements were incorporated into the three fire alarm riser circuits that were installed in three separate locations and within rigid conduit for additional physical protection. The WTC 7 fire alarm single-riser architecture closely mimicked the pre-1993 fire alarm system riser architecture in WTC 1 and WTC 2 that was severed in the bomb blast that disabled all functions of the system. The addition of the survivability enhancements to the post-1993 WTC 1 and WTC 2 fire alarm systems allowed for the continuing functions, albeit degraded, of the systems after the plane impacts.

Another significant difference between the systems was the design development. Whereas the WTC 1 and WTC 2 systems had “Mandated Fire Alarm Guidelines” (WTC 1999) as the basis for the installation of new equipment, there was no documentation available that indicated the same controls were developed for the WTC 7 system. The advantages gained from the use of adopted guidelines are increased reliability and known performance through design and installation controls. This is especially true for large systems that undergo frequent renovations, maintenance, and repairs.

The final major differences were in the commissioning and acceptance procedures. The WTC 1 and WTC 2 fire alarm systems had comprehensive quality assurance procedures to maintain established performance levels for the fire alarm systems. The procedures included specific design, installation, and maintenance requirements. An example of the controls is the verification of the voice loudspeaker system capability to ensure fifty percent of the system remained operable on a floor if there was a loudspeaker circuit failure. The WTC 1 and WTC 2 design criteria provided typical circuit diagrams, design documentation, and quality assurance procedures to make sure this requirement was met. These strict quality controls were implemented because it is extremely difficult without disabling the voice circuit to verify this capability after the system is installed. The WTC 7 documentation does not indicate this level of quality assurance was performed. The maintenance of the records for these processes provided a baseline for determining performance levels at the time of acceptance in comparison to any future date. This baseline was a major factor in maintaining system performance and availability.

The approach taken for the design, installation, and acceptance of the fire alarm system in WTC 7 was an approach that is commonly taken for commercial high rise construction. The absence of design, installation, and commissioning controls mentioned above does not indicate that common practices were not used in the development and installation of the fire alarm system. The comparison suggests that the enhanced measures that the WTC 1 and WTC 2 fire alarm system installations were subjected to during their life-cycle enhanced performance and may have increased survivability.

4.4 FIRE EMERGENCY RESPONSE

WTC 1, 2, and 7 had a fire safety plan that provided direction for fire emergency response and was organized around a hierarchy of staff associated with its implementation. At the top of this hierarchy was the fire safety director. The fire safety director oversaw fire emergency response until the arrival of the FDNY and was responsible for gathering all necessary information for the FDNY, which he/she relayed to the Chief upon arrival.

Subordinate to the fire safety director in WTC 1 and WTC 2 was the assistant fire safety coordinator, who was responsible for the availability and state of readiness of the fire brigade and the entire emergency response team. (Members of the WTC Division of the Port Authority Police, who received firefighting training, staffed the World Trade Center fire brigade.) Similar duties were performed by the fire safety director and his/her deputy at WTC 7. WTC 7 also had a fire brigade that the fire director was responsible for organizing and training.

In addition to the WTC 1 and WTC 2 assistant fire safety coordinator, the facility had an emergency response team consisting of the deputy fire safety directors, lobby deputy fire safety directors, floor wardens, and deputy floor wardens. Deputy fire safety directors were responsible for performing the duties of the assistant fire safety coordinator in his/ her absence and staffing the FCS for the purposes of executing the fire safety plan. At the end of the hierarchical chain for WTC 1, 2, and 7 were floor wardens and deputy floor wardens, who were responsible for assessing conditions and assisting in evacuation of floor occupants on their respective floors upon direction from the fire brigade and/ or FCS. Floor wardens, deputy floor wardens, and their alternates were appointed tenant employees or Port Authority employees.

4.5 SYSTEM PERFORMANCE ON SEPTEMBER 11, 2001

Documenting the actual performance of the WTC 1 and WTC 2 fire alarm systems was hampered significantly by the loss of all historic documentation stored within the buildings, and the loss of electronic files that were generated by the fire alarm system during the events of September 11, 2001. The analysis of the fire alarm's performance was helped significantly by chance video recording of brief images of illuminated status lamps on the fire alarm system's panels located in the WTC 1 FCS, by the crew filming for the Naudet documentary. Additional information was provided by NIST interviews of individuals in the buildings, or in contact with people in the buildings during the event. The former project manager for the fire alarm installation in WTC 1 and WTC 2 was instrumental in clarifying system architecture nuances.

WTC 7 system performance was recorded by the offsite monitoring company. The record from the company provided typical information from monitoring services.

4.5.1 WTC 1 and WTC 2 Observations

The overall impression of the WTC 1 and WTC 2 fire alarm system's performance was that the system did work, but not all functions performed as intended. The performance depended upon which building experienced the alarm condition and the location of the fire alarm function in relation to the impact damage.

The first plane impacted WTC 1 at 8:46 a.m., and floors 93 through 99 experienced extensive and immediate damage. The second plane impacted WTC 2 at 9:03 a.m., and floors 77 through 85 experienced extensive and immediate damage. The following discussion of fire alarm system performance is based upon the interviews and film documentation.

WTC 1 Interviews—The WTC 1 interviews led to the following observations regarding the fire alarm functions:

- There was no confirmation that audible fire alarms were broadcast above the floors of impact.
- There was no confirmation that the emergency voice communication system functioned on any floor within WTC 1 after the impact.
- Confirmation was provided that alarm tones (not voice messages) were heard on the floors below impact. The interviews provided a time of 8:58 a.m. as the time the alarm tones were broadcast, which was 12 min after impact.¹
- There was no confirmation that the floor warden or firefighter telephone system functioned after impact.

¹ NIST Interview data set 2004 and New York City 911 Emergency Call Recording, 2001.

WTC 2 Interviews—The WTC 2 interviews provided the following observations on the fire alarm functions:

- Confirmation was provided that voice messages and alarm tones were broadcast before and after the impact and were heard above the impact floors.²
- **WTC 1 Video Observations**—The Goldfish Pictures video (Fig. 4–10) provided brief images of the fire alarm visual status indicators, along with a timeline to reference the observations. Although the images were limited, the following provides a timeline of the observations:
 - 8:59 a.m. – The WTC 1 Fire alarm panel general alarm visual indication and system fault visual indications were illuminated. Speaker zones 84 and 89 also indicated that they were in a fault condition. The majority of speaker zone lamps on the WTC 1 fire alarm panel were illuminated solid red, which indicated that those speaker zones were in use. Floors 1 through 84 appeared to have their zones illuminated, which indicated activated speakers.³ The exact floors may not have been correct because the observation was based on the personal memory of the fire alarm project manager, and was inconsistent with as-built documentation (Drucker 2004). It is not known if a voice command, or if the alarm tone was broadcast over the activated speaker zones. It is not known if any speaker zones were activated, but the interview transcripts do not include evidence of alarm tones nor voice messages were heard above the 92nd floor of WTC 1.⁴
 - 9:06 a.m. – The alarm slow whoop tone was heard in the lobby.³
 - 9:58 a.m. – The visual indicators on the Concourse and Sub-Grade fire alarm panels indicated that they were in alarm and their notification appliances had been silenced.³
 - 9:58 a.m. – The WTC 2 fire alarm panel redundant displays in WTC 1 indicated that the telephones on floors 64, 71, 73, 93, and 99 of WTC 2 were in use. Zones 76 through 84 on the speaker zones, warden telephone zones, and fireman telephones indicated that they were in a fault condition.³
 - 9:59 a.m. – WTC 2 collapsed, and all video of the fire alarm panels ceased.

² New York City 911 Emergency Call Recordings, 2001.

³ Video from Goldfish Pictures inside WTC 1 showing fire command station and fire alarm system displays, provided to NIST, 2001.

⁴ NIST NCSTAR 1-7, Figure 6–1.



Figure 4–10. Fire alarm system displays at the FCS in WTC 1 showing conditions speaker and telephone circuit faults existing in WTC 2.

Other images of the fire alarm panels for both buildings did not indicate fault conditions on the impact floors or the floors above.³ This absence of numerous visual indicators may have been due to the loss of the communication paths to the remote MXL-VR panels, or PSR panels, or the loss of the panels themselves. The fact that the WTC 2 fire alarm system was able to continue to provide voice communication capability and floor warden telephones after the impact is probably due to Stair C remaining partially intact after the impact, which was where a portion of the audible riser was located, and the survival of the riser in the core area where the telephone riser was located. Of further interest is the visual indication on the FCS fire alarm panel that indicated that the WTC 2 fire alarm system lost communication to a group of PSR panels. Why the PSR panels lost communication is not known, but it would be reasonable to expect physical damage to the circuits. If the MNET circuits were damaged beyond use, survival of the audible circuits is difficult to explain. The facts verify that the audible circuit did survive, and the fact that the system was able to maintain voice communication can only be attributed to the strict criteria required by the PANYNJ to use survivable circuits protected by robust hardware. The performance of other system functions and components within the system were not verifiable without the recovery of records lost with the buildings.

Standpipe telephone handsets were distributed to firefighters dispatched up into WTC 1 and possibly WTC 2. Some firefighters that received standpipe telephone system handsets at the command post in the lobby at WTC 1 were interviewed as part of the investigation. Every one of the firefighters interviewed indicated that they did not use the standpipe telephone communication system on September 11, 2001.⁵ Due to the loss of firefighters in WTC 2, there is no information about the use of the system in WTC 2.

⁵ FDNY Interviews, winter 2004 – summer 2004.

4.5.2 WTC 7 Observations

Information on the performance of the WTC 7 fire alarm system was limited to the record of the offsite system monitoring company on September 11, 2001. The printout shown in Fig. 4–11 indicates the system registered an alarm at 10:00:52 am. This is just after the time for collapse of WTC 2. Even though a fire alarm is indicated, this could be the result of dust entering smoke detectors. Although the entire alarm history record was obtained from AFA Protective Services (AFA), the system monitoring company, the amount of information it shows is typical of system monitoring operations and is meager.

09/11/01	14:48:22	DYJ	4612	**** FULL CLEAR ****		
09/11/01	14:47:22	LATE	3923	SYSTEM TEST OVER		
09/11/01	14:47:22	COMMENT:		TEST: ALL		
09/11/01	14:47:21	COMMENT:		LAST SET: 091101 64742		
09/11/01	10:00:52	1510	CO TO CLASS E	AREA:1		*T
09/11/01	06:47:43	COMMENT:		RIC: WILLIAMS		
09/11/01	06:47:03	RIC	4210	PLACE ON TEST		CAT:11
09/11/01	06:47:03	COMMENT:		091101 647 091101 1447		
09/11/01	06:47:02	COMMENT:		TEST: ALL		
09/11/01	06:05:01	RP		20 TIMER TEST		

Figure 4–11. Monitoring station history tape record for the WTC 7 fire alarm system on September 11, 2001.

The fire alarm history tape record is read from the bottom to the top. Some entries occur as the result of normal operations, and others are the result of actions taken by operators. The bottom line of the record shows that at 6:05:01 a.m. on September 11, 2001, the fire alarm system completed a normal communications check with the central monitoring station. This check was made every day.

At 6:47:02 a.m., AFA placed WTC 7 in a “TEST: ALL” condition. This was normally done in response to a request from the building manager. Ordinarily, it was requested when maintenance or other testing was being performed on the system, so that any alarms that are received from the system are considered the result of the maintenance or testing and are ignored. NIST was told by AFA that for systems placed in the TEST condition, alarm signals are not shown on the operator’s display, but records of the alarm are recorded into the history file.⁶

At 6:47:03 a.m., the record includes an explanation of the request to put the system in the TEST condition. Continuing to read from bottom to top, the date and time the system was placed in TEST is recorded. In this case it is 091101 647 (6:47 a.m., September 11, 2001), and the system will automatically go back to normal monitoring after 8 hr, a system default value, at 091101 1447 (2:47 p.m., September 11, 2001). On the next line above, “RIC” identifies the AFA operator; 4210 is a code number for the “PLACE ON TEST” message. CAT:11 indicates the authority of the person

⁶ Letter from Richard Kleinman, President, AFA Protective Systems, dated July 16, 2003, based on a request by NIST.

requesting the action. On the next line above, the comment entered by RIC identifies that the person who requested that the system be placed on TEST was Williams. This action appears to be common for the building alarm system. Records show that the system was placed on test condition every morning for the seven days preceding September 11, 2001.

At 10:00:52 a.m., a fire condition [1510 CO TO CLASS E] was indicated in WTC 7 by sensing performed by the fire alarm system. The *T at the right end of that record indicates that the system was in TEST at the time. The alarm record also shows that the fire condition is in AREA 1. NIST has been told by AFA that AREA 1 is not a specific area within the building, but a reference to a zone consisting of the entire building.⁶ That is to say, fires detected in any fire alarm zone in the building by the fire alarm system would result in the same AREA 1 identification at the monitoring station. The time 10:00:52 a.m. is shortly after the collapse of WTC 2. It is unknown if this fire alarm was triggered by smoke from a fire or dust entering smoke detectors.

At 2:47:21 p.m. and 2:47:22 p.m. (14:47:21 hr and 14:47:22 hr), at the time the 8 hour “TEST: ALL” condition was set to expire, additional actions were recorded that end in an operator (DYJ) entry to “FULL CLEAR.”

A much greater amount of information would have been collected and recorded by the fire alarm equipment within WTC 7. None of that information was recovered from the building systems. Although a great amount of information is normally collected and stored by any fire alarm system from fire detectors installed throughout a building, typically, and in the case of WTC 7, specific fire information beyond the fact that a fire condition has been detected is rarely sent to the monitoring site.

4.6 SUMMARY OF FINDINGS

The following is a summary of findings based upon the review of the building designs and analysis of the various fire alarm systems as documented in the full report (NIST NCSTAR 1-4C):

- Remote monitoring of the fire alarm systems only provide a time and date of the alarm condition.
- The WTC 1 and WTC 2 fire alarm systems required manual activation of the alarm signal to notify building occupants. This signal was delayed by 12 min after the impact in WTC 1.
- A disparity in performance requirements was found for the different type of circuits common to the fire alarm systems installed in the WTC. As an example, if an event were to cause a short on both circuits, then the Signaling Line Circuit would be able to turn on Notification Appliance Circuits serving the loudspeakers, but the Notification Appliance Circuits providing the voice message or alarm tone to the speakers would not perform.
- Telephone circuits are not presently required to meet specific performance standards. Although manufacturers commonly provide some survivability characteristics, there is not a standard requiring minimum circuit performance. As with the Notification Appliance Circuits, a Signaling Line Circuit with robust survivability performance may be controlling the operation of a telephone circuit, which has minimal survivability performance.

- Although there is evidence that the floor warden telephones were distributed, the interviews of the firefighters conducted by NIST did not confirm that there were any attempts to use the firefighter telephone system. This is not uncommon since the firefighters are trained to use their radios as the preferred means of communication. The firefighter standpipe telephone systems may have been used if active fire fighting operations had been established.
- Although the fire alarm systems in WTC 1 and WTC 2 used multiple communication path risers, the performance of the respective systems degraded as each building was hit by an airplane. This was especially evident in WTC 1 where all fire alarm notification and communication functions appear to have been lost above the floors of impact.
- The fire alarm system installed in WTC 7 sent to the monitoring company only one signal indicating a fire condition in the building on September 11, 2001. This signal did not contain any specific information about the location of the fire within the building. From the alarm system monitor service view, the building had only one zone, "AREA 1."

Chapter 5

SMOKE MANAGEMENT SYSTEMS

In the event of fire in World Trade Center (WTC) 1, 2, and 7 there were two primary means to control smoke movement throughout the building. The first means was the construction of smoke barriers which were typically integrated into the architecture of the building, as well as into the ductwork through which heating, ventilation, and air-conditioning (HVAC) air flowed. The use of smoke barriers is referred to as compartmentation, and walls and smoke dampers are used to form these compartments. The second means was through the use of air movement equipment, either dedicated for smoke management or used to provide HVAC air to the building. The design of the smoke management systems is guided by local building code requirements, widely used and accepted installation standards, and fire protection engineering practice.

The design and installation of the smoke management systems have been documented in National Institute of Standards and Technology (NIST) NCSTAR 1-4D prepared for NIST by subject experts at Hughes Associates, Inc. That publication also includes the results from an analysis of the systems to determine capabilities for various smoke management approaches to WTC 1 and WTC 2. This chapter provides an overview of the work performed by Hughes Associates, Inc. and draws heavily from NIST NCSTAR 1-4D.

5.1 INTRODUCTION TO SMOKE MANAGEMENT

5.1.1 Smoke Management Methods

The movement of smoke can be affected by its temperature (buoyancy), air flow, and barriers it encounters. “Smoke management” is a term used to define the use of active or passive means to minimize or control smoke movement within a building in the event of a fire. Active smoke management generally involves the use of building ventilation systems to control the movement of smoke. Passive smoke management generally involves the use of smoke barriers, such as walls, floors and ceilings and smoke dampers, to provide compartmentation within a building to minimize smoke spread between pre-defined areas of a building typically referred to as smoke zones. Several approaches to active smoke management are presented in the full report (NIST NCSTAR 1-4D); a brief overview of pressurization methods will be presented here as this is the type of system by which the WTC systems could be categorized.

For highly compartmented buildings with predominantly low-ceiling spaces, such as high-rise office buildings (including open-plan office buildings, which are compartmented at the core and floor to floor), the pressurization method is a commonly used smoke management approach. The pressurization method involves the use of mechanical ventilation systems (HVAC systems) to induce a pressure differential across a smoke barrier between the zone of fire origin and adjacent spaces, in order to contain the smoke within the zone of fire origin.

There are two general types of pressurization smoke management systems: positive pressure systems, and negative pressure systems. These two types of systems are depicted in Fig. 5–1. Positive pressurization systems supply air to the zones adjacent to the zone of fire origin to create a positive pressure in the adjacent zones with respect to the fire zone. Negative pressurization systems typically exhaust the zone of fire origin, either alone or in combination with supply in adjacent zones, to achieve the desired pressure differential. The simplest approach is to shut down ventilation airflow to adjacent zones and exhaust air from the zone of fire origin. The benefit of this type of system is that smoke is directly removed from the building, improving conditions within the zone of fire origin and within the building as a whole.

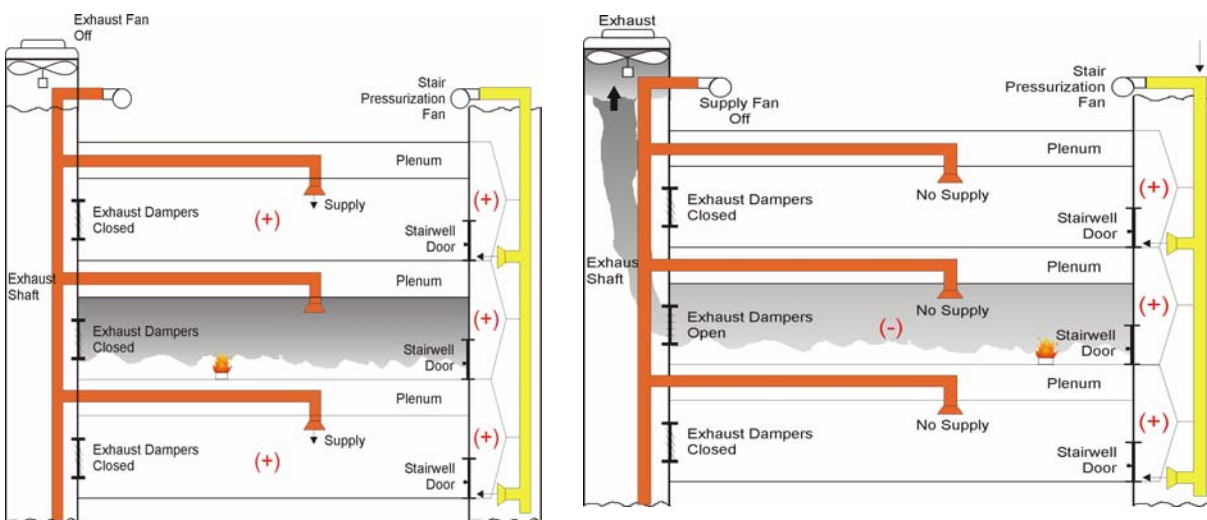

Figure 5–1. Positive (left side) and negative (right side) pressurization smoke management systems.

Stair pressurization is a type of positive pressurization smoke management system and is designed to limit smoke spread into the stairways of buildings such as high-rise buildings. The intent of stairway pressurization systems is to maintain the primary egress paths of a building clear of smoke.

The performance of a building's smoke management systems can be impacted by a number of factors, including stack effect, wind effects, air movement caused by the building's HVAC systems, and temperature effects associated with the fire (i.e., buoyancy and expansion of hot combustion products). Stack effect (or chimney effect) refers to the airflows induced due to the difference in temperature between the indoors and outdoors and, in New York City, is especially an issue in high-rise buildings during the cold winter months when this temperature difference is at its greatest. Wind can act to promote horizontal as well as vertical air movement through a building, depending on the areas open to the outside, resulting in smoke spread from the primary air inlets to the points of outward leakage. For buildings with relatively tight exterior walls and no operable exterior windows, wind effects tend to be minimal on smoke spread within the building. However, should windows be broken out, wind can have a greater impact on smoke spread.

HVAC systems that are not shut down during a fire, or are set in a mode that re-circulates air through the building, may directly cause smoke spread through the building. HVAC ductwork systems are often equipped with duct smoke detectors that shut down the associated fans in an effort to prohibit smoke spread via the fan. However, the open ductwork system may provide another conduit for smoke spread

from floor-to-floor, particularly if the ductwork contains fire dampers rather than smoke dampers. Smoke dampers are designed to prevent the passage of smoke when closed as opposed to fire dampers which are designed to hamper the spread of fire – fire/smoke dampers do both. Also, fire dampers are closed by the presence of heat which physically severs a fusible link, whereas, smoke dampers are closed by a signal from a smoke detector or building control system. Further, smoke dampers are typically designed to fail in the closed position in the event that power is lost to the electronic actuator that closes the device.

Temperature effects are caused by the elevated temperature of the fire/smoke. For an unsprinklered fire, buoyancy of hot fire gases can be a significant contributor to smoke movement through a building. Smoke will form a layer in the upper part of the fire compartment and adjacent spaces, and spread vertically via shaft openings and other openings to floors above. For a sprinklered fire, the contribution of these buoyant forces to overall smoke movement in the building is minimized. Sprinkler water spray tends to cool the hot gases, reducing buoyancy, and stirs the smoke layer, resulting in a more uniform smoke concentration within a compartment.

5.1.2 History of Smoke Management

The following provides a history of smoke management. More details and a detailed review of the evolution of smoke control system requirements in the model building codes are presented in NIST NCSTAR 1-4D.

The origin of smoke management in buildings can be traced to an article that appeared in the National Fire Protection Association (NFPA) Quarterly in 1939, titled *Smoke Hazards of Air-Conditioning Systems* (NBFU 1939). In short, the article states that in the event of fire occurring in an air-conditioned building, it is necessary to shut down the “blowers” so that the movement of air will not augment the fire, and to interrupt the continuity of the duct system using dampers so that smoke, flame, and heat may not travel from their source to the places where damage may be caused. The current air-conditioning standard published by the NFPA, NFPA 90A, contains requirements that are consistent with the findings of the National Board of Fire Underwriters (NBFU) study on which the article is based (Klote 1994). Of note is the idea that the NBFU study examined the use of automatic smoke-tight dampers activated by photoelectric smoke detectors and that such a requirement would not make its way into the building codes until a much later time. The article also states that “with some changes in design, an air-conditioning system could be arranged so as to reverse its flow at time of fire and eject smoke and products of combustion from the building.”

The issue of smoke management in buildings did not gain further momentum until the late 1960s/early 1970s, right about the time that the WTC complex was being designed and built. The first edition of UL 555–*Standard for Fire Dampers* was published in 1968, and over the next few years several symposia and an international conference were held to address fire hazards in buildings and air-handling systems (Klote 1994). Throughout the 1970s, test programs examined the effectiveness of smoke management systems (Klote 1995), including full-scale tests to evaluate the effectiveness of stairway pressurization. In each of these test programs, pressurization smoke management systems were shown to be effective in managing the spread of smoke created by full-scale unsprinklered test fires. The American Society of Heating, Refrigeration and Air-conditioning Engineers (ASHRAE) introduced a handbook chapter titled *Fire and Smoke Control*, providing general information about fire protection, smoke production, smoke

movement, and smoke control (Klote 1994). In subsequent years ASHRAE sponsored a series of seminars to educate design professionals on smoke management system design.

In 1983, ASHRAE published the first version of a document that outlined the engineering principles pertaining to smoke management system design (Klote and Fothergill 1983; Klote and Milke 1995, 2002) and, Underwriters Laboratories published the first edition of UL 555S—*Leakage Rated Dampers for use in Smoke Control Systems*. The 1985 edition of NFPA 90A—*Installation of Air Conditioning and Ventilation Systems* required that smoke dampers be installed in ducts which penetrate smoke barriers, and that the smoke dampers satisfy the provisions of UL 555S. In 1985, the NFPA formed its Technical Committee on Smoke Management Systems. This committee authored the first edition of NFPA 92A—*Recommended Practice for Smoke-Control Systems*, published in 1988. NFPA 92A was intended to be used for systems designed based on the pressurization method of smoke control and brought together many of the previous developments in smoke management system design, referencing UL 555 for fire dampers, UL 555S for smoke dampers, and NFPA 90A for HVAC system design, as well as the ASHRAE text *Design of Smoke Control Systems in Buildings* (Klote and Fothergill 1983) for further guidance on detailed design information. The committee went on to author the first edition of NFPA 92B—*Guide for Smoke Management Systems in Malls, Atria, and Large Areas*, published in 1991.

In 1989, NIST conducted a series of tests of zoned smoke control systems at the Plaza Hotel in Washington, D.C. (Klote 1990). Fans were used to pressurize the stairway, exhaust the fire floor, and pressurize the floors above and below the fire floor. The experiments demonstrated that the smoke control system worked as intended (Klote 1995). The approach used in these tests would later become what is commonly referred to as “sandwich pressurization.”

5.1.3 Applicable Codes and Standards

Construction drawings for WTC 1, 2, and 7 were required by The Port Authority of New York and New Jersey (PANYNJ or Port Authority) to conform to the requirements of the BCNYC. WTC 1 and WTC 2 were constructed under the 1968 edition of the Building Code of the City of New York (BCNYC). WTC 7 was constructed under the 1968 BCNYC, including amendments to January 1, 1985, incorporated in the following local laws enacted after 1968:

- Local Law No. 5, Fire Safety Requirements and Controls, January 18, 1973
- Local Law No. 16, Local Laws of the City of New York for the Year 1984, March 27, 1984
- Local Law No. 33, Local Laws of the City of New York for the Year 1978, October 6, 1978
- Local Law No. 54, Local Laws of the City of New York for the Year 1970, November 17, 1970
- Local Law No. 55, Local Laws of the City of New York for the Year 1976, November 1, 1976
- Local Law No. 84, Fire Safety Pressurization Requirements in Certain Office Buildings, December 13, 1979
- Local Law No. 86, Dates for Compliance with the Local Laws Enacted for Fire Safety Requirements and Controls in Certain Buildings, December 13, 1979

The BCNYC differs from other model building codes in that changes to a building code generally affect only new buildings and are applied to an existing building only when a major renovation or change in occupancy occurs within the building. Many provisions contained within the local laws amending the BCNYC are applied retroactively; thus, these provisions are required to be implemented in existing buildings.

To be consistent with the BCNYC requirements, WTC 1, 2, and 7 were required to be equipped with fire dampers at all duct openings into vertical shaft enclosures and at penetrations of fire resistance rated floors or ceilings. Smoke dampers were required in the main supply duct and main return duct for HVAC systems having a capacity of over 15,000 ft³/min and were arranged to close automatically by the operation of duct smoke detectors. Smoke detectors were required at the return shaft inlet on each floor. Activation of a detector was required to stop air supply to and return from the affected floor. In addition, WTC 7 was required to have either a combined fire/smoke damper or independent fire and smoke dampers at any penetration of construction required to have a fire resistance rating, under the provisions of Local Law #16 pertaining to smoke control.

Local Law #5 required that unsprinklered high-rise buildings be subdivided by fire separations into fire compartments on each floor of the building. WTC 1 and WTC 2 were originally subdivided into quadrants to meet this requirement, but were later provided with full automatic sprinkler protection, negating this requirement. WTC 7 was not required to provide compartmentation, as the building was fully sprinklered at the time of its construction.

Local Law #5 required existing office buildings to be provided with one or more smoke shafts by means of which smoke and heat could be mechanically vented to the outdoors. In lieu of providing smoke shafts, all enclosed exit stairs could be provided with stair pressurization. This requirement applied retroactively to WTC 1 and WTC 2.

Local Law #16 added the requirements for smoke control that included the provision of smoke dampers in HVAC ductwork and separation of ventilation systems serving specified areas of buildings. In addition, a mechanical means to exhaust six air changes per hour, or 1 cfm/ft² (whichever is greater) from the largest floor of a building, operated manually to exhaust one floor at a time, was required. These provisions of Local Law #16 applied to WTC 7.

Local Law #16 required that an emergency power system be provided having the capacity to operate life safety related equipment in high-rise buildings, including ventilation systems for smoke venting or control and stair pressurization. This provision applied to WTC 7 but did not apply retroactively to WTC 1 and WTC 2.

5.2 BUILDING DESCRIPTIONS

Building construction details and building systems in WTC 1, 2, and 7 were evaluated to develop an understanding of building features that may have impacted smoke movement within the buildings or the design/function of smoke management systems. Building HVAC systems are described in somewhat greater detail in order to understand the capabilities of the HVAC systems to perform smoke management functions.

5.2.1 WTC 1 and WTC 2

WTC 1 and WTC 2 were comprised of 110 stories above grade and seven levels below grade and had an approximate footprint area of 42,900 ft². WTC 1 and WTC 2 were similar architecturally, with differences in layout as shown in Figs. 5–2 and 5–3. The interior of each floor differed due to the particular tenant build-out on that floor. In addition, the service core for the north tower (WTC 1) was oriented east/west while the service core for the south tower (WTC 2) was oriented north/south. The service cores contained the elevators, exit stairs, bathrooms, and miscellaneous equipment rooms. The service core gradually decreased in size on the upper floors of the building as the numbers of elevators contained on the floors decreased.

The core spaces were separated from the perimeter spaces in the building by a 2 h fire resistance rated barrier extending slab-to-slab (i.e., between the floor and ceiling slabs). The perimeter office spaces were generally open-plan office spaces containing office cubicles. Individual office spaces on the perimeter were generally separated by non-fire resistance rated partitions extending only to the drop ceiling (i.e., not all the way up to the ceiling slab). The ventilation air plenum above the drop ceiling was open around the perimeter of the floor.

Each tower was provided with three emergency exit stairways, enclosed in 2 h fire resistance rated gypsum wallboard construction. The plan location of the stairways shifted at some levels in order to reduce the occurrence of continuous vertical shafts that extended the entire height of the building. Ninety-nine elevator shafts were located in each building. A system of express and local elevators was installed in the buildings. High-speed express elevators shuttled people from the lobby to sky lobbies on the 44th floor and 78th floor of the building. Escalators connected the sky lobbies to the floors immediately above and below. Local elevators provided access from the sky lobby floors to the upper floors of the building. Freight elevators 49 and 50 extended to different heights in the building, with only freight elevator 50 extending the full height of the building.

Building ventilation (heating and cooling) was provided in WTC 1 and WTC 2 by HVAC systems located in four mechanical equipment rooms (MERs) located on the 7th, 41st, 75th, and 108th floors of each building. Each MER was approximately two stories tall and had an upper and lower level. With the exception of the 108th floor MER, which was located at the top of the building, above the floors that it served, the MERs served the floors immediately above and below the floors on which they were located. The aircraft impact into WTC 1 occurred in the uppermost portion of the building (92nd–98th floors), served from above by the 108th floor MER. The aircraft impact into WTC 2 occurred slightly lower in the building (77th–84th floors), served from below by the 75th floor MER. Figure 5–4 shows the locations of the MERs in elevation view and the location of the aircraft impacts relative to the MERs.

HVAC supply fans were located on the lower level of each MER. Supply air was provided to the building via core, interior, and peripheral HVAC units. There were two core supply ventilation zones (north/south in WTC 2, east/west in WTC 1, due to the orientation of the core), four interior space HVAC zones (corresponding to the four quadrants of the building), and four perimeter zones (north/south/east/west). Each supply fan delivered air to a supply duct network serving the respective HVAC zone associated with the supply fan.



Figure 5–2. Floor layout, 95th floor, WTC 1, North Tower.

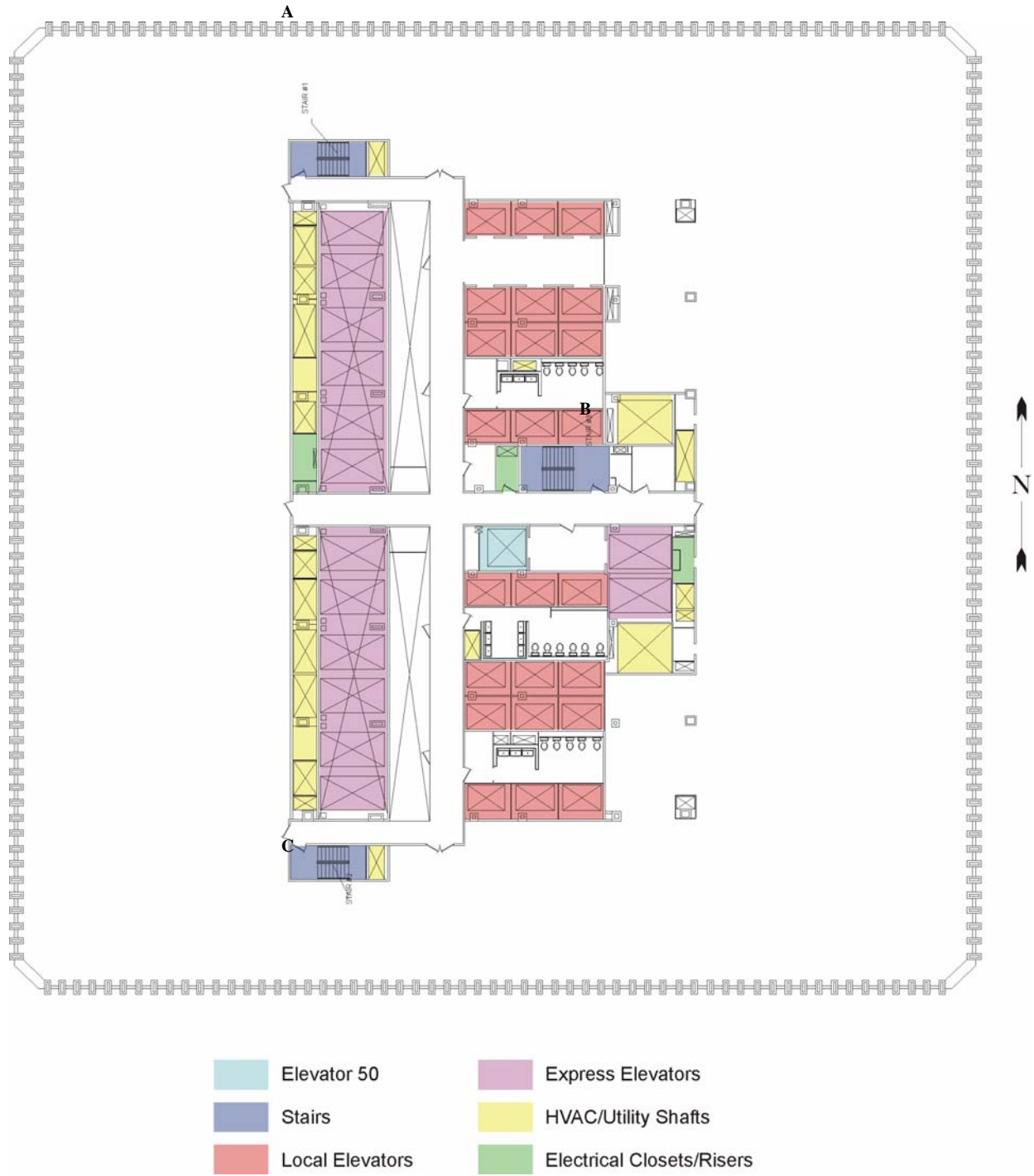

Figure 5-3. Floor layout, 80th Floor, WTC 2, South Tower.

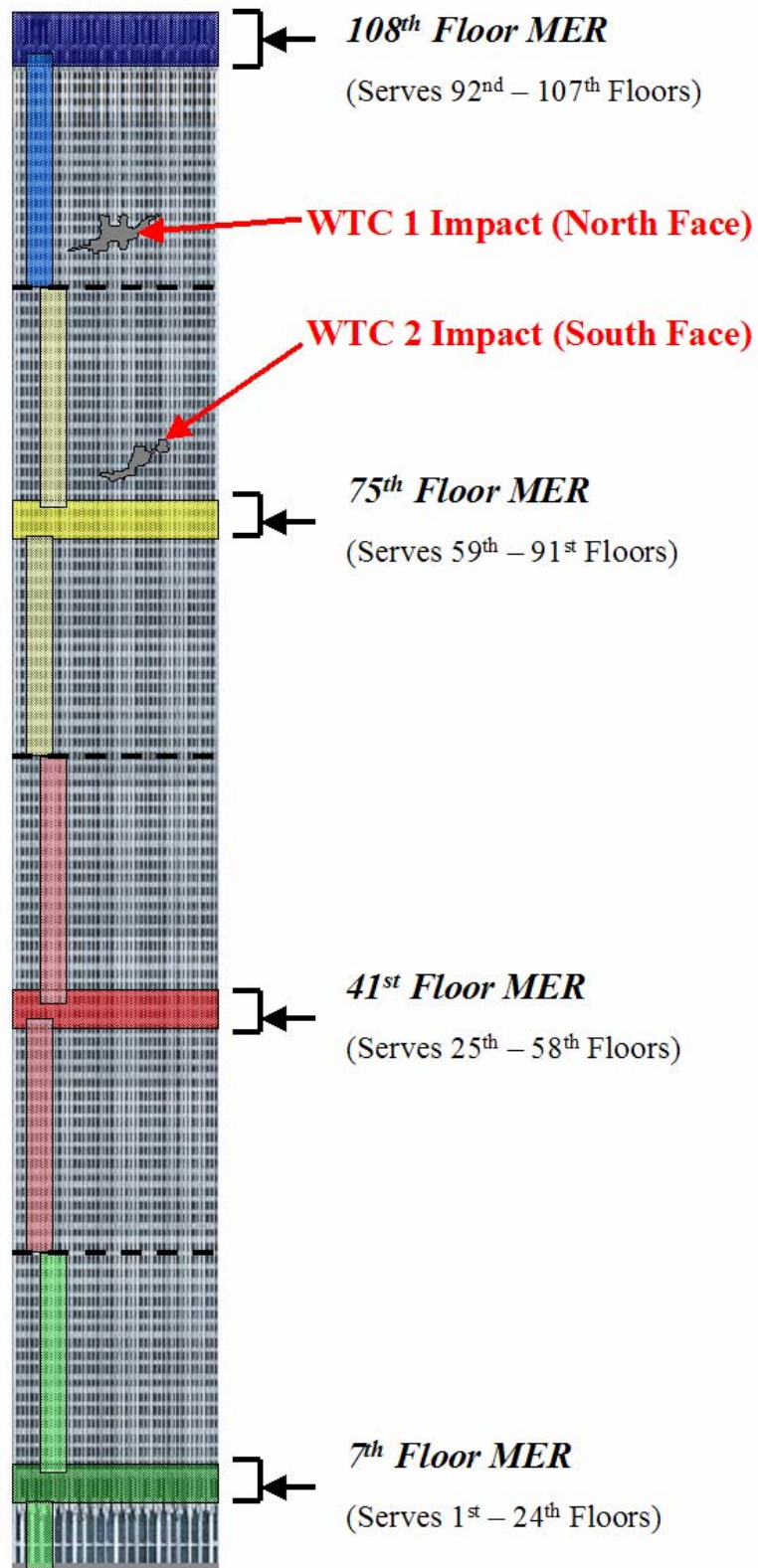

Figure 5-4. Location of MERs, WTC 1 and WTC 2.

Exhaust fans were located on the upper level of each MER. These fans drew air from four sets of vertical return air shafts located along the east and west sides of the core. The gypsum wallboard shafts were connected to return air plenums located above the drop ceiling in the four interior quadrants of each floor via openings between the shaft and plenum. Air was drawn up from the occupied space, through return grilles located in the ceiling tiles and into the ceiling plenum. Return air was then drawn vertically to the MER exhaust fans via the gypsum wallboard shafts. In this manner, the exhaust fan acted to “return” air from the occupied space back to the MER where it could be recirculated back to the supply fans or exhausted out of the building depending on positioning of the main supply, return, and exhaust air dampers. Details of the interaction between the supply and exhaust systems are provided in NIST NCSTAR 1-4D.

The smoke management system (smoke purge) for WTC 1 and WTC 2 utilized only the interior air systems and core systems, which were not modified substantially as a result of tenant retrofits. Perimeter air was not used for smoke management. Further, the return air plenum arrangement and total air quantities remained unchanged, despite individual tenant retrofit configurations. While smoke movement may have been impacted on a given floor due to changes to the ventilation system on individual floors, overall pressure differentials were expected to remain the same.

5.2.2 WTC 7

WTC 7 consisted of 47 stories above-grade and had a footprint area of approximately 48,000 ft². As shown in Fig. 5-5, the service core for the building was located in the east-west direction and contained the elevators, exit stairs, bathrooms, and mechanical/electrical equipment rooms. The perimeter spaces were generally either open-plan office spaces, containing cubicles, or hard-walled individual office spaces. Individual office spaces were generally separated by non-fire resistance rated partitions extending only to the drop ceiling. The ventilation plenum above the drop ceiling was open around the perimeter of the floor. The building was protected throughout by automatic sprinklers with the exception of certain electrical equipment spaces, generator rooms, and bathrooms throughout the building.

The building was served by low-rise (floors 7–20), mid-rise (floors 21–37), and high-rise (floors 38–45) elevators, as well as service and freight elevators that ran the entire height of the building. There were 31 total elevators serving the building. Two exit stairs served the building, and were referred to as Stair 1 (or Stair A) and Stair 2 (or Stair B). The position of Stair 1 remained constant on each floor of the building. The position of Stair 2 shifted at the 23rd floor, due to the location of the low-rise elevators serving the lower floors.

The original building layout consisted of a mechanical equipment room located on each floor. Building ventilation was provided on the tenant floors (floors 7 through 47) for the base building configuration in WTC 7 by supply air fans located on each floor. As shown in Fig. 5-6, conditioned air was distributed to the floor in two zones, corresponding to the north/east, and south/west portions of the building. The fan room served as a return plenum. Return air was drawn into the fan room via ducts that connected the fan room to the return air plenums above the occupied space of each floor. Make-up (outdoor) air was drawn into the fan room via make-up air shafts that connected to the exterior of the building either at the roof or at the 6th floor via louvers through the side of the building.

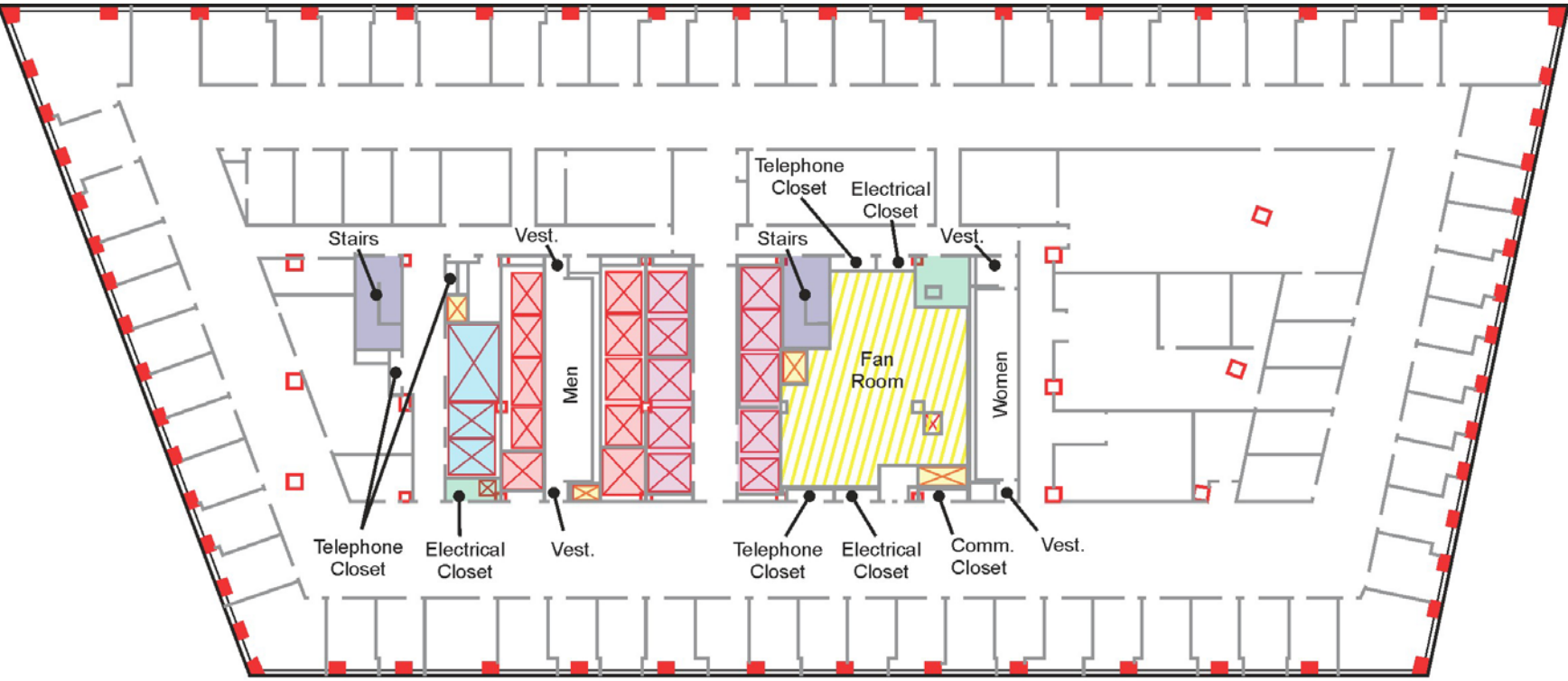



- | | |
|---|---|
|  Stairs |  HVAC/Utility Shafts |
|  Service/Freight Elevators |  Electrical Closets/Risers |
|  Mid-Rise Elevators |  Fan Room |
|  High-Rise Elevators | |

Figure 5-5. Floor layout, 24th floor, WTC 7.



- Supply Fans/Ductwork
- Return Ductwork
- Return Dampers
- Smoke Exhaust/Purge Ductwork
- Smoke Exhaust/Purge Shaft
- Make-up Air Shaft
- Perimeter Hot Water Radiant Heater

Figure 5-6. Air distribution system, 24th floor, WTC 7.

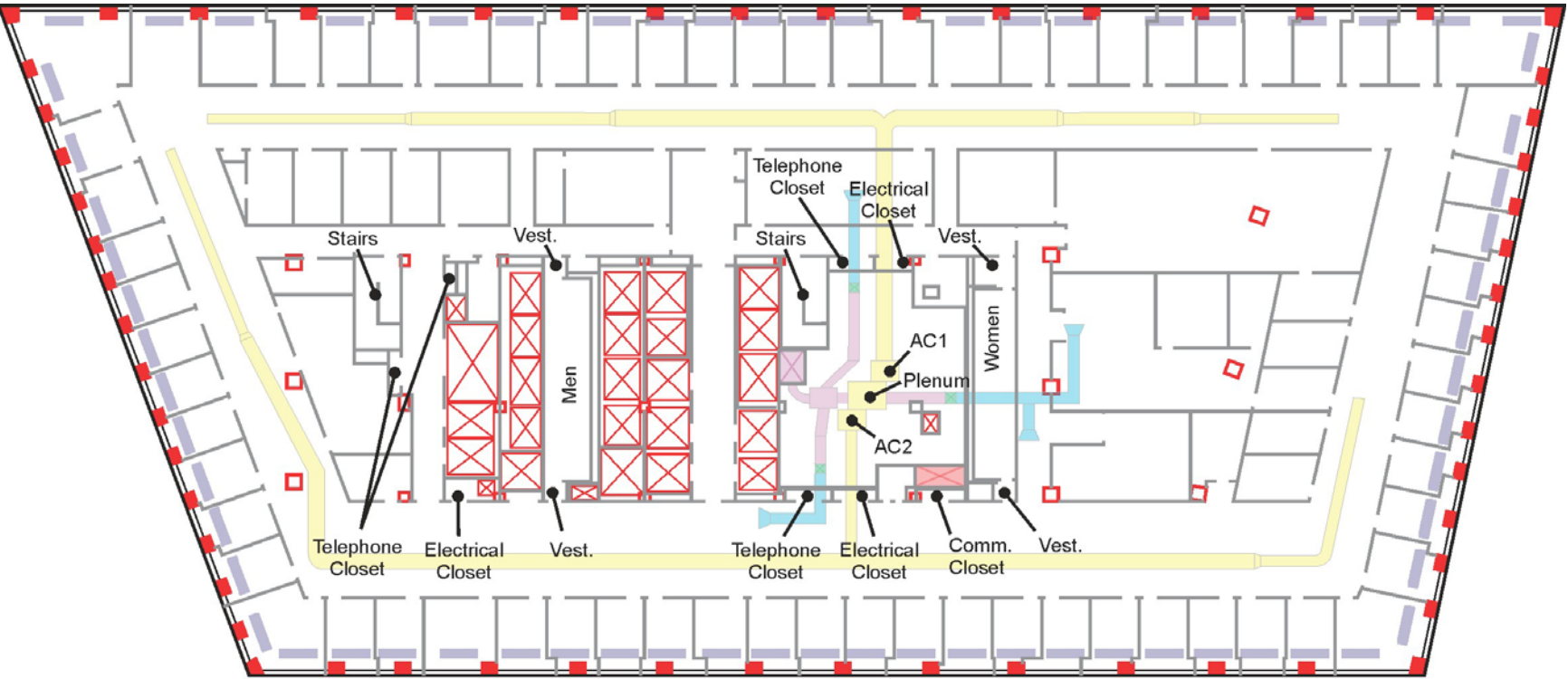
Consistent with the BCNYC, the WTC 7 HVAC systems were designed to incorporate a smoke purge mode, by which each floor of the building could be exhausted/purged of smoke manually on a floor-by-floor basis from the fire command center, which was located on the 3rd floor of the building at the main lobby security desk. Two smoke exhaust fans were originally located within the building on the 6th floor and 47th floor. The return air ductwork was connected to the exhaust duct. Return air either dumped into the fan room via the return dampers in each branch duct or was exhausted via the smoke exhaust riser. A smoke exhaust damper would open at the shaft within each mechanical room, and the return dampers closed to exhaust smoke in the smoke purge mode. Curtain fire dampers were located throughout the building where ductwork crossed fire rated shaft walls, consistent with the BCNYC. Separate pneumatic smoke dampers were used in the fan room to direct airflow within HVAC ductwork.

During the early 1990s, Salomon Smith Barney (SSB) performed a major tenant retrofit to floors 28 through 45. The retrofit included the combining of adjacent floors into single floors, the relocation of HVAC shafts, and the provision of new HVAC equipment to supplement base building equipment. This renovation included changes to the smoke management system, detailed in NIST NCSTAR 1-4D.

5.3 SMOKE MANAGEMENT SYSTEM DESIGN AND INSTALLATION

This section documents the design and installation of the smoke management systems in the towers (WTC 1 and WTC 2) and WTC 7 on September 11, 2001, and compares the system designs to applicable code requirements. The designs were compared to the prevailing requirements of the BCNYC at the time of the event.

In order to document the smoke management systems, multiple sources were reviewed in order to determine how the systems were designed and operated. In the case of WTC 1 and WTC 2, information obtained on the operation of smoke management systems presented conflicting versions of how the systems operated. In the case of WTC 7, the base building systems installed when the building was constructed was modified/supplemented to add smoke management system capabilities during tenant retrofits. Instances where conflicting or incomplete information was provided are fully documented in the full report, NIST NCSTAR 1-4D.

5.3.1 WTC 1 and WTC 2

The tower buildings (WTC 1 and WTC 2) were equipped with a non-dedicated smoke management system (a smoke purge system) that utilized the base building HVAC systems that provided normal ventilation to the buildings. No dedicated smoke management systems were installed in the buildings.

The normal base building HVAC systems could be manually aligned in a smoke purge mode that allowed smoke to be removed from the building. Smoke purge could only be accomplished for an entire ventilation zone served by a particular MER; thus, in the smoke purge mode the entire ventilation zone represented a single smoke zone. Because no operable fire/smoke dampers were present within the ventilation ductwork, it was not possible to provide the smoke purge, or any other smoke management sequence, on a floor-by-floor basis.

Smoke detectors were located at the exhaust duct inlets on each floor and within the HVAC system ductwork in the MER to provide automatic shutdown of individual fans in the presence of smoke. Automatic shutdown of the ventilation systems could be overridden in the smoke purge mode.

The fire safety plan for WTC 1 and WTC 2, revised in January of 1999, defines *smoke purge* as the removal of smoke and other gaseous combustion products from the (fire) area “after a fire has been extinguished.” As documented in the fire safety plan, mechanical systems could be manually adjusted to perform the smoke purge function by the Port Authority mechanical section staff when requested by the chief officer of the responding Fire Department of the City of New York (FDNY) units. The FDNY would ask the WTC fire safety director to provide a smoke purge for a given zone. The WTC fire safety director would then instruct the mechanical section staff to perform the requested action.

The smoke purge sequence is documented in WTC Instruction Manual No. 23, *Operation and Maintenance of Fire Protection System*, dated February 1986. The documented sequence involves using the interior exhaust fans to exhaust an entire multi-floor ventilation zone. Based on the information contained in the fire safety plan for WTC 1 and WTC 2 and WTC Instruction Manual No. 23, it could be concluded that the buildings were equipped with a manual purge system that utilized the interior zone exhaust fans serving the four quadrants of the building to remove smoke after a fire was extinguished. Core supply/exhaust fans and peripheral supply fans would be shut down. Smoke purge could be accomplished within each HVAC zone, the largest of which consisted of 32 floors.

During the course of this investigation, a number of sources were found containing conflicting information regarding how the smoke purge system functioned and how it was intended to be used. Accounts of the 1975 fire, discussed in Chapter 2 (Powers 1975; Lathrop 1975), state that the smoke purge sequence pressurized the core with 100 percent outside air and exhausted 100 percent from the office spaces. These accounts also state that during the 1975 fire, the smoke purge sequence for the fire floor and adjacent floors was initiated from the appropriate MER shortly after discovery of the fire, once police had examined the fire floor and identified the presence of a significant fire. This documented sequence of events is important, as it signifies that the system was used at that time as an active fire protection system, to control smoke during the fire event and that the mode of operation differed from the that contained in the 1986 Instruction Manual No. 23.

As part of this investigation, the Port Authority was asked to clarify the operation of the smoke purge sequence, since the available information regarding its intended operation provided conflicting accounts of smoke purge operation. According to the Port Authority, smoke purge would occur by starting the supply and exhaust fans serving one of the four interior quadrants within a ventilation zone. Core supply/exhaust fans and peripheral supply fans would be shut down. HVAC systems serving the other ventilation zones in the building would be left operating unless they were shut down at the direction of FDNY. The Port Authority further recognized that WTC Instruction Manual No. 23 had not been updated since the base building fire alarm system was upgraded after the 1993 bombing. Therefore, this manual did not always reflect the most current fire protection system configuration.¹

Operation of the smoke management system for WTC 1 and WTC 2 could be achieved by controlling the equipment within the individual MERs or at a central control panel located in the Operations Control

¹ E-mail communication from the PANYNJ, dated February 18, 2004, responding to questions posed by NIST.

Center (OCC) located on the B1 level of WTC 2. At either location, building personnel had to perform two distinct operations:

- Configuring the HVAC systems in smoke purge mode
- Starting the appropriate HVAC fans

Operation of the purge switch aligned all dampers that served as part of that quadrant's HVAC systems in a 100 percent outside air configuration. This would mean that supply and spill dampers would be fully open and that recirculation dampers would be closed.

To achieve the smoke purge, it was up to the operator of the systems to turn on those fans necessary to achieve system operation. It would have been equally possible to initiate an exhaust only type sequence as outlined in the fire safety plan, the core pressurization sequence (supply and exhaust operating) reportedly initiated during the 1975 fire, or the sequence stated by the Port Authority as the smoke purge sequence in effect on September 11, 2001. Alignment of the system would be up to the understanding of the operator as to the proper function of the smoke purge sequence, when called upon to initiate this sequence.

With regard to the use of the smoke purge function to aid in active smoke management system during a fire event versus during post-fire cleanup operations, it would be up to the responding fire department personnel to initiate system operation. Depending on the type of fire event, it was possible that the system could have been used either during the fire or after it was extinguished.

At the time the buildings were constructed, the ability to provide a smoke purge from each HVAC zone was the only smoke management system provided in the buildings. Local Law # 5 retroactively imposed the requirements for smoke shafts for existing high-rise buildings, when it was enacted in 1973. In lieu of such smoke shaft(s), stair pressurization systems could be provided.

In order to respond to the requirements of Local Law #5, the Port Authority initiated a pilot study into the requirements for pressurizing the exit stairs in WTC 1 and WTC 2. Stair pressurization was examined as a means of meeting the requirements of Local Law #5 since the smoke shaft requirements would have been prohibitive for a building the size of WTC 1 and WTC 2. Existing buildings that were sprinklered throughout were exempt from the smoke shaft and optional stair pressurization requirement by the requirements of Local Law #86 (enacted in 1979). A decision was made at some subsequent time to fully sprinkler the WTC buildings. Therefore, the Port Authority did not move forward with the stair pressurization option. Because WTC 1 and WTC 2 were fully retrofitted with automatic sprinklers, smoke and heat venting and/or stair pressurization was not required in WTC 1 and WTC 2 on September 11, 2001.

As shown in Fig. 5–7, WTC 1 and WTC 2 were equipped throughout with fire dampers at duct penetrations into vertical shafts, consistent with the BCNYC. Combination fire/smoke dampers were not required by the code to be provided in existing buildings. Since tenant retrofit projects generally connected to the existing base building systems, fire/smoke dampers at HVAC shafts were not generally provided during tenant retrofits.

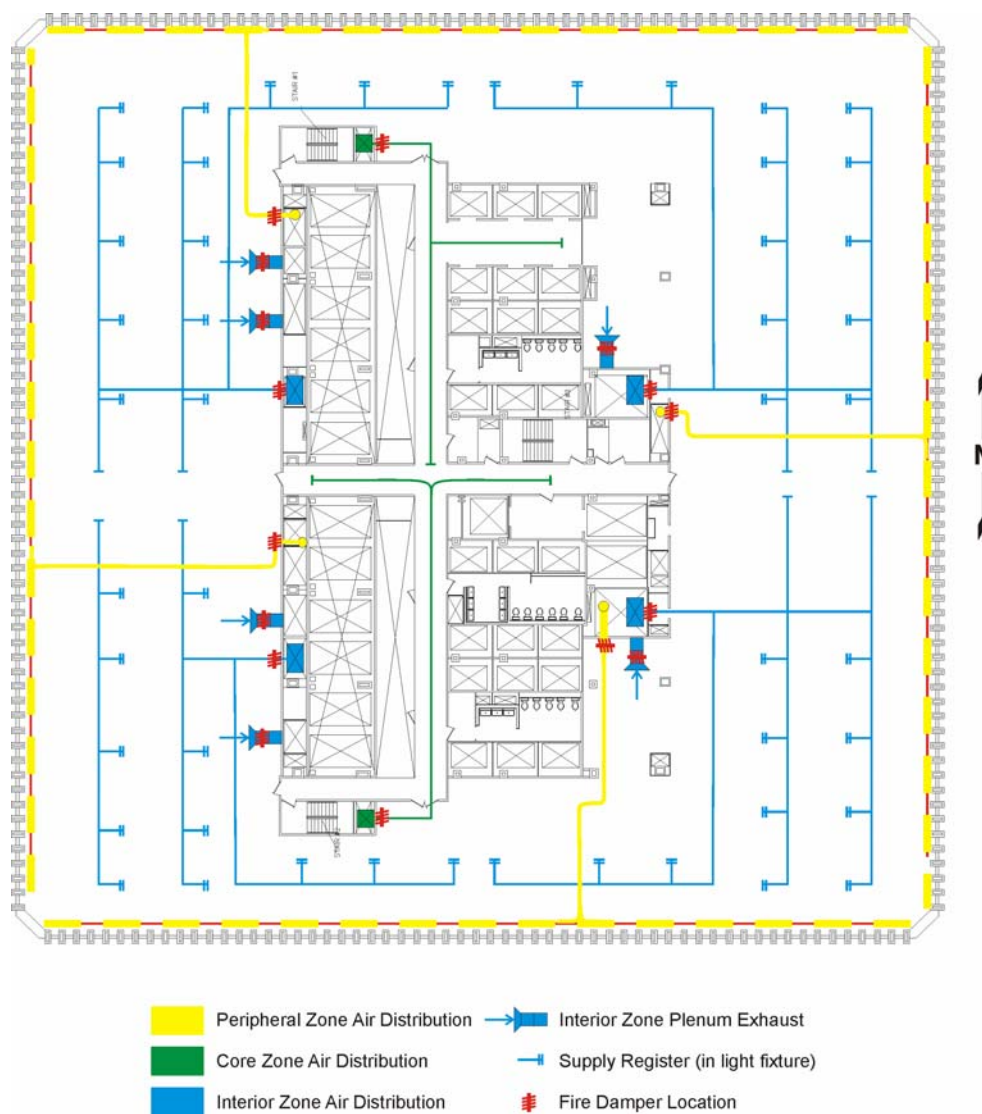

Figure 5-7. Air distribution system, 80th floor, WTC 2.

Emergency power was not retroactively required by the BCNYC, but was provided subsequent to the 1993 bombing for WTC 1 and WTC 2, serving all emergency systems (lighting, fire alarm system, etc.) and the building elevators. While one account summarizing the building restoration activities following the 1993 bombing suggested that emergency power was provided for smoke purge fans, the Port Authority stated that emergency power was not provided to WTC 1 and WTC 2 base building smoke purge fans.² However, the MERs were equipped with redundant power sources from different substations.

No other redundant features were identified with respect to the HVAC systems used to accomplish the smoke purge functions. No backup system or emergency power was provided.

² E-mail communication from the PANYNJ, dated February 18, 2004, responding to questions posed by NIST.

5.3.2 WTC 7

WTC 7 was equipped with a dedicated smoke management system (a smoke purge system) that utilized dedicated HVAC equipment that served only a smoke management function. This type of system differed from that used in WTC 1 and WTC 2, which utilized the HVAC systems that provided normal ventilation to the buildings to perform the smoke purge function. In WTC 7, dedicated smoke exhaust fans/dampers could be manually aligned at the fire command center to provide smoke purge from a specified floor within the building. Since the smoke purge function could be provided on a floor-by-floor basis, each floor of the building constituted an individual smoke control zone.

The building operations manual for WTC 7 specified three alarm modes pertaining to operation of the building HVAC systems. ALARM-1 initiated shutdown of HVAC equipment based on duct smoke detection. ALARM-2 initiated smoke purge on the affected floor. ALARM-3 specified the smoke purge sequence for non-affected floors. The smoke management sequence pertaining to the smoke purge function involved exhausting the fire floor and pressurizing the remaining floors with supply air.

Local Law #16 required that all buildings in occupancy group E (business) be provided a manual override capability to be capable of exhausting one floor at a time at a rate of six air changes per hour, or 1 cfm/ft², whichever is greater. For WTC 7, with a footprint area of approximately 48,000 ft², this would require an exhaust capacity of at least 48,000 ft³/min (81,552 m³/h). The base building system serving the lower floors of the building provided a smoke exhaust capacity of 36,000 ft³/min (61,164 m³/h), which was not consistent with the minimum value specified by code. An 84,000 ft³/min (142,716 m³/h) exhaust fan was provided for the SSB floors during the tenant retrofit, which exceeded the capacity required by code.

WTC 7 was sprinklered throughout and was, therefore, exempted from the requirement for stair pressurization systems. The building was provided with a Class E fire alarm system consistent with the code, was provided with emergency power serving all emergency systems, and was equipped throughout with fire dampers at duct penetrations into vertical shafts, consistent with the BCNYC.

5.4 EVALUATION OF SYSTEM PERFORMANCE ON SEPTEMBER 11, 2001

This section documents the normal operation of the fully functional smoke management systems on smoke conditions in WTC 1 and WTC 2 on September 11, 2001. Elements of this task involved the evaluation of expected system performance for postulated design fires in business occupancies, as well as documentation of the expected performance of fully functional smoke management systems in the towers.

The smoke management systems in WTC 1 and WTC 2 were designed to provide a manually-initiated smoke purge function. Given the design and intended operation of the smoke management systems, two key questions were sought to be answered to ascertain the performance of the system on September 11, 2001:

- Was the smoke purge system in either WTC 1 or WTC 2 manually initiated by emergency response personnel?
- Were the systems capable of operating given the damage caused by the aircraft impacts on each building?

In order to answer the second question, damage to both the building electrical and mechanical systems needed to be evaluated. It was first necessary to determine whether electrical power was available to the building mechanical systems subsequent to impact so that they were capable of operating. Then, potential damage to HVAC system components was evaluated to determine if the systems were capable of performing as designed.

5.4.1 Actions of Emergency Response Personnel

The events of September 11, 2001, clearly represented an extreme challenge, both to emergency response personnel and to the installed building systems. The damage caused by an aircraft impact into a building is outside the range of typical design considerations for the design of most building systems, including fire protection systems.

The WTC fire safety director on duty stated that no recommendation was given on his part to initiate a smoke purge sequence, nor was smoke purge performed on September 11, 2001, to his knowledge.³ NIST found no record of FDNY personnel having initiated a smoke purge sequence in WTC 1 or WTC 2.

5.4.2 Damage to System Components

The exact extent of damage within individual floors of WTC 1 and WTC 2 may never be known, since the collapse of the buildings prohibited a detailed inspection of the impact area. However, the potential extent of damage was estimated based on the results of engineering analysis and based on observations recorded by people located within WTC 1 and WTC 2 at the time of the events.

Potential damage estimates were overlaid onto representative floor plans for the impact areas in WTC 1 and WTC 2 in order to determine the potential damage to key electrical/mechanical system components located in the core spaces. The damage estimates were corroborated to a certain extent using observations made by people located in various locations in the buildings after aircraft impact. The observations primarily have to do with stair shaft damage, damage to freight elevator 50, and in some cases elevator shafts. HVAC shaft data could be corroborated using visual evidence of smoke spread seen from the exterior of the building. An attempt was also made to corroborate the extent of core damage using observations as to the presence of power in the building.

5.4.3 Summary of System Performance on September 11, 2001

Examination of the available evidence provided strong indications that the smoke management systems in WTC 1 and WTC 2 played no role in the events that occurred on September 11, 2001. There was no evidence to support the fact that an attempt was made to activate the smoke purge sequence.

If a decision had been made to attempt to align the building ventilation systems into the smoke purge mode, it is unclear that this would have had any impact on overall smoke conditions within the building. Since the WTC 1 impact occurred near the boundary between ventilation zones at the 91st/92nd floors, smoke purge may have been inadvertently initiated for the 59th–91st floor HVAC zone in WTC 1, rather than the HVAC zone for the upper floors.

³ PANYNJ Interview 3, fall 2003.

The aircraft impacts caused significant damage to the core spaces in both WTC 1 and WTC 2, making it unlikely that the smoke purge could have been accomplished in either building. In WTC 1, it is likely that the impact eliminated or significantly impaired electrical power on floors above the impact zone. Therefore, because power would not have been available at the 108th floor MER (which served the zone of impact) HVAC systems likely would not have been operational. In addition, the ventilation shafts for at least the north half of the building were likely damaged, thus reducing the possibility for the smoke purge to function properly even if the HVAC systems had been operable.

In WTC 2, it is possible that electrical power may have been available to the fans located in the 75th floor MER, which was located below the impact zone in this building. Survivor accounts indicate that power may have been available up to the 75th floor and visual evidence suggests power was available even above the floors of impact (Beyler 2002). Initially, all fans would have shut down due to detection of substantial quantities of smoke by the duct smoke detectors. The HVAC shafts utilized to accomplish smoke purging would likely have been damaged on the east side of the building, eliminating half of the smoke venting capacity for the floor. Even if the ventilation shafts on the west side of the building remained intact, the performance of the smoke venting system would have been reduced. This would have had a particularly detrimental impact on WTC 1, where smoke conditions deteriorated in the uppermost portions of the building at a much faster rate than WTC 2.

5.5 EVALUATION OF POTENTIAL SMOKE MANAGEMENT SYSTEM EFFECTIVENESS

In order to fully understand the potential impact of smoke management systems for events like those occurring on September 11, 2001, it is important to analyze how various smoke management system configurations might have performed in WTC 1 and WTC 2 had they been available on September 11, 2001. To develop an understanding of the capabilities of the various smoke management system configurations that were evaluated, it is also important to analyze their performance for other hypothetical fire scenarios in high-rise buildings, both typical/expected design scenarios and worst case scenarios. All of the smoke management approaches analyzed utilized some variation of the pressurization method of smoke management.

The performance of each of the smoke management approaches, given the postulated design fire scenarios, was evaluated using the CONTAM building airflow and contaminant dispersal model (Dols and Walton 2002). CONTAM is a recognized tool for the evaluation of smoke management systems that are based on the pressurization method of smoke management.

The various codes and standards that reference the use of pressurization smoke control require the provision of 0.05 in. H₂O (12.5 Pa) pressure differentials in sprinklered buildings and 0.1 in. H₂O (25 Pa) in non-sprinklered buildings to contain smoke. It is important to note, however, that these pressures are measured with a building's HVAC systems placed in smoke management mode, without the presence of a fire. The required pressure differentials are high enough to contain heated smoke were a fire to be present in sprinklered and non-sprinklered occupancies, and are used for design purposes.

5.5.1 Smoke Management System Approaches

Five distinct smoke management approaches were examined for the WTC towers. These approaches are as follows:

- Smoke Purge
- Core Pressurization
- Building Pressurization
- Sandwich Pressurization
- Zoned Smoke Control with Stair Pressurization

The smoke purge approach is based on the documented smoke purge sequence for WTC 1 and WTC 2 as it appears in WTC Instruction Manual No. 23, *Operation and Maintenance of Fire Protection System*, dated February 1986. The sequence involved placing the interior HVAC zone exhaust fans and core exhaust fans (toilet exhausts, elevator machine room (EMR) exhausts) in the multi-floor ventilation zone containing the fire in 100 percent exhaust mode. HVAC systems in all other ventilation zones in the buildings were aligned in a summer normal mode. Peripheral supply fans were shut down.

The core pressurization approach is a slight variation of the documented smoke purge sequence for WTC 1 and WTC 2, in that the supply fans, rather than the exhaust fans, in the core were activated to pressurize the core, in an effort to prohibit smoke spread into the core from the surrounding office spaces. Accounts of the 1975 fire and other sources cite this variation as being the “smoke purge” sequence provided for the building.

The building pressurization approach was recommended to be used in the event of a severe fire involving a substantial portion of one floor of the building, where windows were observed to be broken out (HAI/DCE 1996). The approach involves turning on the supply fans in the entire building and turning on the exhaust fans only in the ventilation zone of fire origin. The intent of this approach was to exhaust smoke, where possible, from the floor containing the fire and to induce a substantial airflow toward the floor of fire origin to force smoke out of the broken windows.

The sandwich pressurization approach typically involves exhausting the floor of fire origin and pressurizing the floors above and below. The HVAC systems in WTC 1 and WTC 2 were not equipped with operable fire/smoke dampers; thus, it was not possible to configure the system to exhaust and supply to only single floors within a ventilation zone. Instead, an approach was examined where the sandwich was achieved by ventilation zones. In the event of a fire, the ventilation zone of origin would have all of its exhaust fans turned on, and supply fans turned off. The ventilation zones above and below would have all supply fans activated and exhaust fans turned off. These actions would create a multi-floor sandwich effect in the building, with the net effect being the creation of a pressure differential between the core and perimeter spaces within the HVAC zone of fire origin.

The final approach, zoned smoke control with stair pressurization, was a hypothetical approach based on best practices in smoke management system design enforced in many jurisdictions in the United States as

of September 11, 2001. It was assumed that the building was retrofitted with stair pressurization systems, as required for all new high-rise construction by the model building codes in the United States, and was capable of exhausting on a floor by floor basis within the ventilation zone containing the fire to create the desired pressure differential with respect to the floors above and below. Other ventilation zones were assumed to operate in the summer normal mode. It was assumed that operable fire/smoke dampers were also installed in all supply/exhaust ducts at the appropriate shaft connections and that these dampers were closed within the zone of fire origin.

5.5.2 Design Fire Scenarios

Several different design fire scenarios were evaluated for WTC 1 and WTC 2, encompassing the range of expected fires that could be envisioned within the office spaces of the building. The fire scenarios were limited to those that could occur on the above-grade office floors of the building. Other fire scenarios are possible that could result in smoke migration through the towers due to a fire in the sub-grade areas or adjacent spaces within the WTC complex (i.e., truck dock fire, car fire in the garage, fire in the concourse). Because the focus of this report is on examining the fires that occurred on September 11, 2001, (which occurred on the uppermost floors of the building) and bounding these events with other comparable fires, it was desirable to examine only those fire scenarios on the office floors of the building. The design fire scenarios that were evaluated are as follows:

- Sprinklered Fire
- Full-Floor Burnout
- Two-Floor Fire
- WTC 1 and WTC 2, September 11, 2001 Fire Scenarios (No Shaft Damage)
- WTC 1 and WTC 2, September 11, 2001 Fire Scenarios (Shaft Damage Assumed)

The first fire scenario assumes that a typical fire in a sprinklered building would either be controlled or extinguished by the automatic sprinkler system. It was assumed that the temperature in the zone of origin never exceeded the operation temperature of the sprinklers, which were assumed to have an activation temperature of 165 °F (74 °C). Given the large size of the majority of the office spaces in the towers, some of which encompassed an entire floor, the average temperature throughout the floor would be expected to be less than the assumed 165 °F.

The second fire scenario, the full-floor burnout scenario, is considered a worst-case design scenario for a fire involving the contents of a typical office building. In a fully-sprinklered building, a full-floor burnout would only be possible given some sort of catastrophic failure of the sprinkler system or given a fuel load that exceeded the capacity of the sprinkler system. The full floor burnout fire scenario evaluated in this report assumed a temperature on the floor of fire origin of 1,800 °F (1,000 °C). It was further assumed that 58 windows on each face were broken out.

The third fire scenario, the two-floor fire scenario, corresponds to a multi-floor event. The purpose of this fire scenario was to examine smoke management system performance for a multi-floor fire scenario of far less severity than the aircraft impact scenario that occurred on September 11, 2001. It was assumed that

an explosion had opened up a 100 ft² (9.3 m²) hole in the floor slab at the midpoint along one of the faces of the building. The average temperature on the two floors was assumed to be identical to that of the sprinklered fire scenario, 165 °F (74 °C).

The fourth fire scenario was a hypothetical fire scenario in which the majority of the structural damage occurring on September 11, 2001, was modeled, but with no shaft damage occurring in the building's core. This scenario, although unlikely, was modeled to estimate the performance of the candidate smoke management system approaches for a scenario involving a multi-floor fire event with high temperatures throughout the fire compartment and large openings in the exterior of the building.

The fifth fire scenario was an attempt to model smoke management system performance given conditions close to what actually may have existed in WTC 1 and WTC 2 on September 11, 2001. Estimates made as to the size of the exterior openings after aircraft impact, including impact damage and window breakage, were used along with the preliminary damage estimates to model the damage to shafts within the core of each building. Where the extent of damage was unknown, estimates had to be made with regard to the extent of damage. Temperatures of 750 °F (400 °C) and 1,800 °F (1,000 °C) were used to model the temperature throughout the impact zone. For all cases, the outside air temperature was modeled as 70 °F (21 °C) with the wind out of the north at 11.2 mi/h (5 m/s).

5.5.3 Results of the Analysis

Five candidate smoke management system approaches were evaluated to determine whether each of these approaches could provide adequate pressurization to contain smoke to the zone of fire origin for five postulated fire scenarios.

The *smoke purge* approach and the *core pressurization* approach were shown to create adequate pressure differentials for only the sprinklered fire scenario. Substantial negative pressure differentials, indicating flow of smoke from the zone of fire origin into the core, occurred for each of the other fire scenarios.

The *building pressurization* approach created high pressure differentials from the core to the perimeter office spaces for all fire scenarios except the multi-floor September 11 aircraft impact scenarios. Positive pressures were demonstrated for both the undamaged core and shaft damage September 11 scenarios in WTC 1, but sufficient airflow velocity was not created to prohibit smoke spread via large openings in ventilation shafts and in the core/office space boundaries resulting from aircraft impact damage. Use of the building pressurization method could potentially create excessive door opening forces that could hinder or prohibit the egress of building occupants. The magnitude of the door opening forces is a function of the fire scenario, size of interior and exterior openings, and location of the floor(s) of fire origin relative to the location of the MER.

The *zoned smoke control with stair pressurization* approach was shown to be effective for the sprinklered fire scenario, the full-floor burnout, and the two-floor fire. For each of these fire scenarios, however, stack effect was shown to have a substantial impact on the performance of the system, in some cases causing airflow from the floor of fire origin into the core. Therefore, this approach might not be effective using a single speed fan, or set airflow quantity. It is likely that fan speed would have to be adjusted based on differential pressure readings to ensure the success of a smoke management system using this approach. Because the zoned smoke control method involves exhausting from a single floor of the

building, it was not effective for the multi-floor aircraft impact scenarios. In addition, stair pressurization did not prohibit smoke spread into the stairs when large openings in the stairway walls were present due to aircraft impact damage.

The *sandwich pressurization* approach was determined to be effective for the sprinklered fire, full-floor burnout, and two-floor fire scenarios, even in the presence of stack effect. Positive pressures were demonstrated in the model scenarios for both the undamaged core and shaft damage September 11 scenarios in WTC 1, but sufficient airflow velocity was not created to prohibit smoke spread via large openings into ventilation shafts or the core resulting from aircraft impact damage.

5.6 SUMMARY OF RESULTS

The following is a summary of findings based upon the review of the building designs and analysis of various smoke management systems as documented in the full report (NIST NCSTAR 1-4D):

- The smoke management systems in WTC 1 and WTC 2, which provided the capability for a manual smoke purge within an individual HVAC zone on a quadrant-by-quadrant basis, were not initiated on September 11, 2001.
- Had the smoke purge sequence been initiated in WTC 1 or WTC 2, it is unlikely the system would have functioned as designed, due to loss of electrical power and/or damage to the HVAC shafts and other structural elements in the impact zone that were an integral part of the smoke purge system.
- WTC 1 and WTC 2 were not required by the 1968 BCNYC, as amended by Local Law 5 and Local Law 86, to have active smoke and heat venting and/or stair pressurization because they contained automatic sprinklers throughout.
- None of the potential smoke management system configurations evaluated in this report would have provided sufficient pressure differentials to contain smoke for the postulated aircraft impact damage scenarios, even if these systems were capable of operation after the building sustained damage from the aircraft impact.
- During the events occurring on September 11, 2001, stair pressurization would have been ineffective in improving conditions for occupants trying to exit the building.
- Installation of combination fire/smoke dampers in HVAC ductwork, which was not required in WTC 1 or WTC 2, may have acted to slow the development of hazardous conditions on the uppermost floors of the building, but would likely not have had a significant effect on the ability of occupants to egress the building due to the impassibility of the exit stairways.

This page left intentionally blank.

Chapter 6

ACTIVE FIRE PROTECTION SYSTEMS: SUMMARY OF INVESTIGATION FINDINGS

The active fire protection systems installed in World Trade Center (WTC) 1, 2, and 7 were designed to alert building occupants to the smoke and heat produced early in a fire, to activate sprinklers in the fire zone when a threshold temperature was reached, and to manage the smoke in a way that aided evacuation and fire fighting operations. The successful operation of these systems depended upon the fire threat being consistent with what had been anticipated based upon previous experience and best engineering practices of the day.

The history of fires in WTC 1 and WTC 2 includes fire events in spaces with and without sprinklers. Except for the fires of September 11, 2001, all of the fires that occurred in sprinklered spaces were controlled with three or fewer sprinklers, in some cases supplemented by manual fire fighting. Prior to the installation of sprinklers, a major office fire occurred in 1975, involving approximately one quarter of one floor, and which spread through openings in the floor slabs to several other floors. The 1975 fire caused buckling of some components of the composite trussed floor system on the fire floors. Only three documented fires occurred in WTC 7 prior to 2001, and none did significant damage.

The fire history and examination of documents indicated that the active fire protection systems in WTC 1, 2, and 7 were well designed; however, the systems played virtually no part in the course of events on September 1, 2001. The impact of the aircraft superceded the need for a standard alarm system to alert occupants to the unfolding danger in the buildings, even to those not in WTC 1 when the first airplane hit (although an awareness of the exact nature, location and severity of the situation remained a significant issue throughout the incident). The sprinkler systems were damaged, overtaxed by the size of the fires, and deprived of essential power or water supplies. The smoke management systems, if they had been activated, would have been ineffective due to the amount of smoke produced in the fires and the loss of integrity in separating walls and shafts.

While the active fire protection systems used in WTC 1, 2, and 7 were unable to perform as designed on September 1, 2001, due to the severity of the damage and size of the fires, this investigation uncovered a number of significant findings related to the strengths and vulnerabilities of these systems. The key findings that were developed in the previous chapters are summarized below, organized to emphasize two general themes with implications relative to fire and building codes, standards, and practices:

- the minimum level of performance for active fire protection systems hardware
- the quantity and reliability of information available and provided to first responders and occupants for management of emergency response and evacuation, and for investigation purposes.

6.1 MINIMUM LEVEL OF PERFORMANCE FOR ACTIVE FIRE PROTECTION SYSTEMS HARDWARE

6.1.1 Fire Suppression Systems and Water Supply

- In general, the water supplies, automatic sprinklers and standpipe/pre-connected hose systems in WTC 1, 2, and 7 were determined to be robust, and exceeded the minimum applicable code requirements, as well as associated engineering best practices.
- Except for specific areas that were exempted from required sprinkler coverage, sprinkler systems for fire control were installed throughout WTC 1, 2, and 7. Such systems are expected to “control” fires until the fire department can initiate suppression operations and extinguish the fire.
- The water supplies for WTC 1 and WTC 2 and floors 21 through 47 of WTC 7 included large capacity storage tanks and direct connections to the New York City (NYC) water distribution system. These supplies provided redundant sources of water for the standpipe and sprinkler system infrastructures. The storage tanks provided adequate duration of supply for normally expected fire exposures to allow the fire department to respond and supplement the demand.
- The lower floors (1 through 20) in WTC 7 were supplied directly from the NYC water distribution system through two service lines from the street main on Washington Street. An automatic fire pump was used to supply the water to the combined sprinkler and standpipe risers. The water supply tanks located in the upper part of the building did not service the lower floors. A manual fire pump and secondary connection to the NYC water system were provided for the lower floors rather than using water supply tanks. Therefore, there would not have been a secondary source of water in the event the NYC system became inoperable.
- The installation of the supply piping from the storage tanks on the 110th floor in WTC 1 and WTC 2 resulted in restricted flow capacity to several floors in the mid-level water supply zones in both buildings. While the flow capacity was sufficient to supply the sprinkler and standpipe systems, the installation was not consistent with engineering best practices.
- The suppression systems in WTC 1, 2, and 7 required manual operation of fire pumps in order to provide secondary water. Whether or not the building maintenance engineering staff performed this task on September 11, 2001, could not be confirmed.
- The supply risers and related infrastructure for the automatic sprinkler systems in WTC 1, 2, and 7 were configured to provide redundant capabilities. However, the typical floor level sprinkler system was installed with one connection to the infrastructure riser, providing a single point of failure of the water supply to the floor level sprinklers.
- According to available documentation, the sprinkler system met or exceeded the applicable installation requirements in the Building Code of the City of New York (BCNYC) and National Fire Protection Association (NFPA) 13, with most spaces being classified as Light Hazard occupancy. There were several design features that were considered inconsistent with

engineering best practices, but no evidence was found to indicate that these features affected the events that occurred on September 11, 2001.

- Based on hydraulic analyses, it was estimated that the sprinkler systems could have provided fire control at coverage areas up to two or three times the specified design area of 1,500 ft². However, 4,500 ft² constituted less than 15 percent of the area of a single floor in these buildings, and estimates of the extent of the initial fires in WTC 1 and WTC 2 in 2001 were considerably greater than three times the specified design areas. Additionally, the aircraft impact damaged the sprinkler system infrastructure, reducing effectiveness. Once the number of open sprinklers or the extent of system damage area exceeded an area equivalent to two or three times the design areas, the system's ability to control the fire would have been reduced and the duration of the primary water supply would have rapidly degraded. Even if the systems had been designed to protect much higher hazard levels (i.e., Ordinary Group II or Extra Hazard), the magnitude of these fires would have resulted in the fires not being controlled.
- Documentation indicated that the standpipe pre-connected hose system installations were consistent with the applicable requirements in the BCNYC. They were not consistent with the flow rates and durations required in NFPA 14.
- Sprinklers were not installed in the fifth floor generator room in WTC 7, nor was information found to indicate that the generator/fuel day-tank enclosures elsewhere in WTC 7 were protected by automatic sprinklers or other special hazards protection.
- Primary and backup power was provided in all three buildings, but the absence of remote redundancy of the power transmission lines to emergency fire pumps could have affected the operability of the sprinkler and standpipe systems once power was lost.
- The roles of the special fire suppression systems that were installed in WTC 1, 2, and 7 on September 11, 2001, could not be determined due to the absence of any information regarding their performance.

6.1.2 Building Fire Alarm and Communications Systems

- The WTC 1 and WTC 2 fire alarm systems required manual activation of the alarm signal to notify building occupants. This signal was delayed by 12 min after the impact in WTC 1.
- A disparity in performance requirements was found for the different type of circuits common to the fire alarm systems installed in the WTC. As an example, if an event were to cause a short on both circuits, then the Signaling Line Circuit would be able to turn on Notification Appliance Circuits serving the loudspeakers, but the Notification Appliance Circuits providing the voice message or alarm tone to the speakers would not perform.
- Telephone circuits were not required to meet specific performance standards. Although manufacturers commonly provide some survivability characteristics, there is not a standard requiring minimum circuit performance. As with the Notification Appliance Circuits, a

Signaling Line Circuit with robust survivability performance may be controlling the operation of a telephone circuit, that has minimal survivability performance.

- Although the fire alarm systems in WTC 1 and WTC 2 used multiple communication path risers, the systems experienced performance degradation on September 11, 2001, especially in WTC 1 where all fire alarm notification and communication functions appear to have been lost above the floors of impact.

6.1.3 Smoke Management Systems

- The smoke management systems in WTC 1 and WTC 2, which provided the capability for a manual smoke purge within an individual heating, ventilation and air-conditioning (HVAC) zone on a quadrant-by-quadrant basis, were not initiated on September 11, 2001.
- Had the smoke purge sequence been initiated in WTC 1 or WTC 2, it is unlikely that the system would have functioned as designed, due to loss of electrical power and/or damage to the HVAC shafts and other structural elements in the impact zone that were an integral part of the smoke purge system.
- WTC 1 and WTC 2 were not required by the 1968 BCNYC, as amended by Local Law 5 and Local Law 86, to have active smoke and heat venting and/or stair pressurization because they contained automatic sprinklers throughout.
- None of the potential smoke management system configurations evaluated in this report would have provided sufficient pressure differentials to contain smoke for the postulated aircraft impact damage scenarios, even if these systems were capable of operation after the building sustained damage from the aircraft impact.
- Modeling results showed that in WTC 1 and WTC 2 stair pressurization systems would have provided minimal resistance to the passage of smoke had they been installed on September 11, 2001. Multiple stair doors being open for substantial periods of time due to occupant egress and stairway walls damaged by aircraft impact would result in an inability to prevent smoke from entering stairwells.
- Installation of combination fire/smoke dampers in HVAC ductwork, which was not required in WTC 1 or WTC 2, may have acted to slow the development of hazardous conditions on the uppermost floors of the building, but would likely not have had a significant effect on the ability of occupants to egress the building due to the impassibility of the exit stairways.

6.2 QUANTITY AND RELIABILITY OF INFORMATION AVAILABLE

6.2.1 For Fire Status Monitoring and Fire Fighting Activities

- Alarm systems in WTC 1, 2, and 7 were only capable of determining and displaying (a) areas that had at some time reached alarm point conditions and (b) areas that had not.

- The alarm systems in WTC 1 and WTC 2 were monitored by The Port Authority of New York and New Jersey; however,
- No information was available outside of the systems.
- WTC 1 had an overwhelming number of alarms registered and displayed (scrolling) at the fire command station (FCS); however, no information was available at the FCS about the water supply in areas that were burning.
- The WTC 7 alarm system recorded information at one location in the building: the FCS in the 3rd floor lobby.
- The fire alarm system installed in WTC 7 sent to the monitoring company only one signal indicating the time and date of a fire condition in the building on September 11, 2001. This signal did not contain any specific information about the location of the fire within the building. From the alarm system monitor service view, the building had only one zone, "AREA 1."
- Although there is evidence that the floor warden telephones were distributed, the interviews of the firefighters conducted by National Institute of Standards and Technology did not confirm that there were any attempts to use the firefighter telephone system. This is not uncommon since the firefighters are trained to use their radios as the preferred means of communication. The firefighter standpipe telephone systems may have been used if active fire fighting operations had been established.

6.2.2 For Assisting Evacuation

- There was no means at the FCS to determine whether or not announcements made in WTC 1 and WTC 2 reached and could be heard on intended floors.
- Alarm systems collect information that is valuable for understanding the fire and smoke development in a building.
- In WTC 1, fire and other automatic alarm information at the FCS was not used to manage evacuation.

6.2.3 For Investigative Purposes

- The extensive backup command capabilities and hardware installed in WTC 1 and WTC 2 provided multiple places in the building where some alarm history data were stored. Up to 13 locations have been identified.
- No information from the fire alarm systems was located, and there was no indication that anyone looked for it during the clean-up of the WTC site.

- Transmission of critical data outside the building to a monitoring station would provide one means to preserve event data. Although modern systems are capable of this communication, it is not done in practice.
- Survivability of alarm systems data on computer hard drives, memory modules, or printouts in building fires and collapse environments is not addressed in present installation standards.

Chapter 7

REFERENCES

- Beyler, C. L. 2002. Analysis of the Fire Aspects of the World Trade Center Terrorist Attacks: 11 September 2001. Hughes Associates Inc. Baltimore, MD, July 31.
- Bryan, J. L. 1990. *Automatic Sprinkler and Standpipe Systems*. National Fire Protection Association, Quincy, MA, August.
- Cote, A. 2003. *Fire Protection Handbook*, 19th ed., National Fire Protection Association, Quincy, MA.
- Dols, W. S., and G. N. Walton. 2002. CONTAM 2.0 User Manual: Multizone airflow and containment transport analysis software. NISTIR 6921, National Institute of Standards and Technology, U.S. Department of Commerce, Washington, DC.
- Drucker, J. 2001a. Presentation on the World Trade Center Fire Alarm System. Siemens Building Technologies.
- Drucker, J. 2001b. Remembering the World Trade Center. October.
- Drucker, J. 2004. Personal Communications.
- HAI (Hughes Associates, Inc.) and DCE (Dillon Consulting Engineers). 1996. *Smoke Management Evaluation Study of The World Trade Center Complex Excluding the Concourse and Plaza*. Prepared for the PANYNJ (Port Authority of New York and New Jersey). New York, NY.
- HRS Systems, Inc. 2004. Hass (Hydraulic Analyzer of Sprinkler Systems) Version 7.5. Software. 2004.
- Gensler and Associates. 1995. American Express Bank: Sprinkler Plan, New York, NY, January.
- Isner, M. S. and T. J. Klem. 1993a. Explosion and Fire Disrupt World Trade Center. *NFPA Journal*: 91-104.
- Isner, M. S. and T. J. Klem. 1993b. World Trade Center Explosion and Fire, New York, New York, February 26, 1993. Fire Investigation Report, National Fire Protection Association, Quincy, MA.
- Klote, J. H. 1990. *Fire Experiments of Zoned Smoke Control at the Plaza Hotel in Washington, DC*. NISTIR 90-4253. National Institute of Standards and Technology. Gaithersburg, MD.
- Klote, J. H. 1994. Fire and smoke control: an historical perspective. *ASHRAE Journal*, July.
- Klote, J. H. 1995. An overview of smoke control research. *ASHRAE Transactions: Symposia*. Vol. 101, No. 1.

- Klote, J. H., and J. W. Fothergill. 1983. *Design of Smoke Control Systems for Buildings*. U.S. Department of Commerce, National Bureau of Standards. Washington, DC.
- Klote, J. H., and J. A. Milke. 1995. *Design of Smoke Management Systems*. American Society of Heating, Refrigerating and Air-Conditioning Engineers (ASHRAE). Atlanta, GA.
- Klote, J. H., and J. A. Milke. 2002. *Principles of Smoke Management*. American Society of Heating, Refrigerating and Air-Conditioning Engineers (ASHRAE). Atlanta, GA.
- Lathrop, J. K. 1975. "World Trade Center Fire, New York, New York." *Fire Journal*. July.
- LZA Technology. 2002. *Damage/Debris Assessment Report*. New York, NY, August.
- Merritt & Harris Inc. 2000. Color Photographs from Report 20-251E, *Property Condition Assessment of World Trade Center Portfolio*, of the exterior and interior of WTC 1 and WTC 2, Retail Mall and Plaza, Central Plant, and Sub-grade. Photograph. 2000.
- NBFU (National Board of Fire Underwriters). 1939. *Smoke Hazards of Air-Conditioning Systems*.
- NFPA 13. Standard for the Installation of Sprinkler Systems, National Fire Protection Association, Quincy, MA (2002 ed.).
- NFPA 14. Standard for the Installation of Standpipe and Hose Systems, National Fire Protection Association, Quincy, MA (2000 ed.).
- NFPA 14. Standard for the Installation of Standpipe and Hose Systems, National Fire Protection Association, Quincy, MA (2003 ed.).
- PACO Group, Inc. and Flack & Kurtz, Inc. 2002. Final Preliminary Report – General Description of All Building Systems and the Capital Program, January 14.
- PANYNJ (Port Authority of New York and New Jersey). 1972. World Trade Center: PONYA Office Space - Tower A - Fire Protection Drawings. New York, NY, April.
- PANYNJ (Port Authority of New York and New Jersey). 1987. *World Trade Center Instruction Manual No. 18: Operation and Maintenance of Sprinkler Systems*. New York, NY, April.
- PANYNJ (Port Authority of New York and New Jersey) document, 1993. The Port Authority of New York and New Jersey (non-public document), *Authority to Purchase, Order number 50329 to Bob Salamone*, March 17, 1993.
- PANYNJ (Port Authority of New York and New Jersey). 2000. Design Guidelines, Guide Specifications, and Standard Details: HVAC, Plumbing, and Fire Protection. New York, NY September.
- Powers, W. R. 1975. One World Trade Center Fire, New York, N.Y., February 13, 1975. National Fire Protection Association, Boston, MA, 1-15.

Syska & Hennessy Group Inc. 1984. 7 World Trade Center: Summary of Mechanical and Electrical Systems. New York, NY, May.

This page left intentionally blank.