

NATIONAL AERONAUTICS AND SPACE ADMINISTRATION

SPACE SHUTTLE MISSION STS-56

PRESS KIT
APRIL 1993



ATLAS 2 MISSION
Atmospheric Laboratory For Science And Applications

STS-56 INSIGNIA

STS056-S-001 – The STS-56 Discovery, Orbiter Vehicle (OV) 103, mission insignia is a pictorial representation of the STS-56 Atmospheric Laboratory for Applications and Science 2 (ATLAS-2) mission as seen from the crew's viewpoint. The payload bay (PLB) is depicted with the ATLAS-2 pallet, Shuttle Solar Backscatter Ultraviolet (SSBUV) experiment, and Spartan -- the two primary scientific payloads on the flight. With ATLAS-2 serving as part of the "Mission to Planet Earth" project, the crew has depicted the planet prominently in the artwork. Two primary areas of study are the atmosphere and the sun. To highlight this, Earth's atmosphere is depicted as a stylized visible spectrum and the sunrise is represented with an enlarged two-colored corona. Surnames of the mission commander and pilot are inscribed in the Earth field, with the surnames of the mission specialists appearing in the space background. They are mission commander Kenneth Cameron, pilot Stephen S. Oswald, and mission specialists Michael Foale, Kenneth D. Cockrell, and Ellen Ochoa. Each crewmember contributed to the design of the insignia.

The NASA insignia design for space shuttle flights is reserved for use by the astronauts and for other official use as the NASA Administrator may authorize. Public availability has been approved only in the form of illustrations by the various news media. When and if there is any change in this policy, which we do not anticipate, it will be publicly announced.

PHOTO CREDIT: NASA or National Aeronautics and Space Administration.

PUBLIC AFFAIRS CONTACTS

NASA Headquarters

Office of Space Flight/Office of Space Systems Development
Mark Hess/Jim Cast/Ed Campion
(Phone: 202/358-1778)

Office of Space Science and Applications
Paula Cleggett-Haleim/Mike Braukus/Brian Dunbar
(Phone: 202/358-1547)

Office of Space Communications/Office of Safety & Mission Quality
Dwayne Brown
(Phone: 202/358-0547)

Office of Advanced Concepts and Technology
Charles Redmond
(Phone: 703/358-1757)

Office of Aeronautics
Drucella Andersen/Les Dorr
(Phone: 202/453-2754)

Ames Research Center, Moffett Field, CA
Jane Hutchison
(Phone: 415/604-4968)

Langley Research Center
Catharine Schauer
(Phone: 804/864-6122)

Ames-Dryden Flight Research Facility, Edwards, CA
Nancy Lovato
(Phone: 805/258-3448)

Lewis Research Center
Mary Ann Peto
(Phone: 216/433-2899)

Goddard Space Flight Center, Greenbelt, MD
Ranee Exler
(Phone: 301/286-7277)

Marshall Space Flight Center
June Malone
(Phone: 205/544-0034)

Jet Propulsion Laboratory
James Wilson
(Phone: 818/354-5011)

Stennis Space Center
Myron Webb
(Phone: 601/688-3341)

Johnson Space Center, Houston, TX
James Hartsfield
(Phone: 713/483-5111)

Wallops Flight Center
Keith Koehler
(Phone: 804/824-1579)

Kennedy Space Center, FL
George Diller
(Phone: 407/867-2468)

Department of Defense

Secretary of the Air Force Public Affairs
Maj. Dave Thurston
(Phone: 703/695-5766)

USAF Space and Missile Systems Center Public Affairs
Betty Ciotti
(Phone: 310/363-6836)

Dave Hess
(Phone: 713/483-3498)

CONTENTS

GENERAL BACKGROUND	
General Release	5
Media Services Information	7
Quick-Look-Facts	8
Space Shuttle Abort Modes	9
Summary of Major Activities	10
Payload and Vehicle Weights	11
CARGO BAY PAYLOADS & ACTIVITIES	
Atmospheric Laboratory for Applications & Science 2	12
Shuttle Pointed Autonomous Research Tool for Astronomy-201	25
Solar Ultraviolet Experiment (SUVE)	26
MIDDECK PAYLOADS	
STS-56 Education Activities	28
Hand-held, Earth-oriented, Real-time, Cooperative, User-friendly, Location-targeting and Environmental System (HERCULES)	29
Radiation Monitoring Experiment-III (RME-III)	31
Cosmic Radiation Effects and Activation Monitor (CREAM)	31
Air Force Maui Optical Station (AMOS)	31
Shuttle Amateur Radio Experiment (SAREX)	33
Commercial Materials Dispersion Apparatus ITA Experiment	34
Space Tissue Loss (STL)	43
Physiological & Anatomical Rodent Experiment (PARE.03)	45
CREW BIOGRAPHIES & MISSION MANAGEMENT	
STS-56 Crew Biographies	49
Mission Management for STS-56	52

STS-56 MISSION CONTINUES NASA'S MISSION TO PLANET EARTH

A variety of scientific questions will be addressed when NASA conducts Shuttle mission STS-56 in late March 1993. The crew on Space Shuttle Discovery will gather data on the relationship between sun's energy output and Earth's middle-atmosphere chemical make-up and how these factors affect the Earth's ozone level.

The crew will use the Atmospheric Laboratory for Science and Applications (ATLAS 2) and Shuttle Backscatter Ultraviolet (SSBUV) payloads aboard Discovery to gather this information.

The source of solar wind and the possible applications a microgravity environment can provide for research in drug development and the changes which occur in muscles and bones in a weightless condition are some of the other areas to be investigated during the STS-56 mission.

The STS-56 crew will be commanded by Kenneth D. Cameron who will be making his second Shuttle flight. Stephen S. Oswald will serve as Pilot and will be making his second flight. Rounding out the ATLAS 2 crew will be three mission specialists - Michael Foale, making his second space flight and Kenneth D. Cockrell and Ellen Ochoa who will be making their first flight.

Launch of Discovery is currently targeted for late March from Kennedy Space Center's (KSC) Launch Complex 39-B. After launch, the STS- 56 crew will work in two teams, each on 12 hour shifts, making observations and collecting data with the experiments and instruments being carried on the mission. The mission is scheduled to last 8 days and conclude with a landing at KSC's Shuttle Landing Facility.

ATLAS 2 is the primary payload for the STS-56 mission, the second in a series of missions which will track subtle, year-to-year variations in solar activity and in atmospheric composition. The ATLAS series is a vital part of NASA's "Mission to Planet Earth," a long-term effort to study the Earth as a global environmental system. The SSBUV experiment which is co-manifested with ATLAS 2, provides calibrated ozone data contributing to the Mission to Planet Earth data set.

The Space Shuttle is the ideal platform for NASA's remote- sensing atmospheric laboratory. The flight crew can maneuver the orbiter so the instruments in the bay point precisely toward the atmosphere, the sun or the Earth's surface as necessary for scheduled observations.

The Shuttle's generous payload capacity and power supply allow a diverse assembly of large instruments to make simultaneous remote observations. The Shuttle-borne ATLAS 2/SSBUV instruments make more detailed measurements than similar instruments now flying aboard satellites. France, Belgium and Germany are providing three of the ATLAS 2 instruments.

Also flying in Discovery's payload bay will be the Spartan-201, a free- flying payload to study the velocity and acceleration of the solar wind and to observe aspects of the sun's corona. Results should help scientists understand the physics of the sun's corona and the solar wind. When the Shuttle's payload bay doors are open, a crew member will use the Remote Manipulator System (RMS) to lift the Spartan from its rack and release it over the side of the Shuttle.

Spartan is deployed from the Shuttle so that Spartan can operate independently, turning and pointing at the sun, while leaving the orbiter free for other activities. After completing its observations, Spartan- 201 will be retrieved using the RMS and will be stowed back in the cargo bay to be returned to Earth.

NASA's long standing educational outreach efforts will be highlighted in two STS-56 experiments - the Solar Ultraviolet Experiment (SUVE) and the Shuttle Amateur Radio Experiment (SAREX).

SUVE will be carried in a Get-Away-Special (GAS) canister in Discovery's cargo bay. The SUVE experiment will study the extreme ultraviolet solar radiation as it affects the Earth's ionosphere. SUVE was developed by students at the Colorado Space Grant Consortium, a group of 14 colleges and universities with funding from NASA. NASA's GAS program provides low-cost access to space for high school and college students as well as other small research groups.

The Shuttle Amateur Radio Experiment-II (SAREX-II) provides public participation in the space program, supports educational initiatives and demonstrates the effectiveness of making contact between the Space Shuttle and low-cost amateur "ham" radio stations on the ground. On STS-56, crew members Ken Cameron, Ken Cockrell, Mike Foale and Ellen Ochoa will use SAREX-II as a secondary payload. Operating times for school contacts are planned into the crew's activities. The school contacts generate interest in science as students talk directly with the astronauts.

Several experiments, previously flown on Shuttle missions, are aboard Discovery on the STS-56 mission.

The Hand-held, Earth-oriented, Real-time, Cooperative, User-friendly, Location-targeting and Environmental System (HERCULES) experiment, which flew on STS-53 in December 1992, again will test a system developed to allow a Shuttle astronaut in space to point a camera at an interesting feature on Earth, record the image and determine the latitude and longitude of the feature.

The Air Force Maui Optical Station (AMOS) experiment, which has been a part of numerous Shuttle missions, will fly on the STS-56 mission. The AMOS is an electro-optical facility located on the Hawaiian island of Maui. The facility tracks the orbiter as it flies over the area and records signatures from thruster firings, water dumps or the phenomenon of "shuttle glow."

Two other experiments which have flown before, Space Tissue Loss-3 and Physiological and Anatomical Rodent Experiment (PARE.03) will use different methods to address the issue -- why bones and muscles change when they experience a weightless condition.

The Radiation Monitoring Equipment-III (RME-III), flown on several missions, and the Cosmic Radiation Effects and Activation Monitor (CREAM), which last flew on STS-44 in November 1991, will be a part of the STS-56 mission. RME-III is an instrument which measures the exposure to ionizing radiation on the Space Shuttle. It displays the dose rate and total accumulated radiation dose to the astronaut operator. The CREAM experiment is designed to collect data on cosmic ray energy loss spectra, neutron fluxes and induced radioactivity. The data will be collected by active and passive monitors placed at specific locations throughout the orbiter's cabin.

The STS-56 mission will be the 16th flight of Space Shuttle Discovery and the 55th flight of the Space Shuttle.

(END OF GENERAL RELEASE; BACKGROUND INFORMATION FOLLOWS.)

MEDIA SERVICES

NASA Select Television Transmission

NASA Select television is available on Satcom F-2R, Transponder 13, located at 72 degrees west longitude; frequency 3960.0 MHz, audio 6.8 MHz.

The schedule for television transmissions from the orbiter and for the mission briefings will be available during the mission at Kennedy Space Center, FL; Marshall Space Flight Center, Huntsville, Ala.; Ames-Dryden Flight Research Facility, Edwards, Calif.; Johnson Space Center, Houston and NASA Headquarters, Washington, DC. The television schedule will be updated to reflect changes dictated by mission operations.

Television schedules also may be obtained by calling COMSTOR 713/483-5817. COMSTOR is a computer data base service requiring the use of a telephone modem. A voice update of the television schedule is updated daily at noon EST.

Status Reports

Status reports on countdown and launch, on-orbit activities and landing operations will be produced by the appropriate NASA newscenter.

Briefings

A mission press briefing schedule will be issued prior to launch. During the mission, mission status briefings by a flight director or mission operations representative and representatives from the science team will occur at least once per day. The updated NASA Select television schedule will indicate when mission briefings are planned.

STS-56 QUICK LOOK

Launch Date/Site: Late March, 1993/Kennedy Space Center - Pad 39B
Launch Time: 12:50 a.m. EST
Orbiter: Discovery (OV-103) - 16th Flight
Orbit/Inclination: 160 nautical miles/57 degrees
Mission Duration: 8 days, 6 hours, 6 minutes
Landing Time/Date: TBD
Primary Landing Site: Kennedy Space Center, Fla.
Abort Landing Sites: Return to Launch Site - KSC, FL
Trans-Atlantic Abort landing - Zaragoza, Spain; Ben Guerir, Morocco;
Moron, Spain
Abort Once Around - White Sands, N.M.

Crew: Kenneth D. Cameron, Commander (CDR)
Stephen S. Oswald, Pilot (PLT)
Michael C. Foale, Mission Specialist 1 (MS1)
Kenneth D. Cockrell, Mission Specialist 2 (MS2)
Ellen Ochoa., Mission Specialist 3 (MS3)

Blue Team: Cameron, Oswald, Ochoa
Red Team: Cockrell, Foale

Cargo Bay Payloads: ATLAS 2 (Atmospheric Lab for Applications and Science-2)
SSBUV-A (Shuttle Solar Backscatter Ultraviolet-A)
SPARTAN-201 (Solar Wind Generation Experiment)
SUVE (Solar Ultraviolet Experiment)

In-cabin Payloads: CMIX (Commercial Materials Dispersion Apparatus)
PARE (Physiological and Anatomical Rodent Experiment)
HERCULES (Hand-held, Earth-oriented, Real-time, Cooperative,
User-friendly, Location-targeting and Environmental System)
SAREX-II (Shuttle Amateur Radio Experiment-II)
STL (Space Tissue Loss)
AMOS (Air Force Maui Optical System)
CREAM (Cosmic Ray Effects and Activation Monitor)
RME-III (Radiation Monitoring Equipment-III)

SPACE SHUTTLE ABORT MODES

Space Shuttle launch abort philosophy aims toward safe and intact recovery of the flight crew, orbiter and its payload. Abort modes include:

- Abort-To-Orbit (ATO) -- Partial loss of main engine thrust late enough to permit reaching a minimal 105-nautical mile orbit with orbital maneuvering system engines.
- Abort-Once-Around (AOA) -- Earlier main engine shutdown with the capability to allow one orbit around before landing at White Sands Space Harbor.
- Trans-Atlantic Abort Landing (TAL) -- Loss of one or more main engines midway through powered flight would force a landing at either Zaragoza, Spain; Ben Guerir, Morocco; or Moron, Spain.
- Return-To-Launch-Site (RTL) -- Early shutdown of one or more engines, without enough energy to reach Zaragoza, would result in a Shuttle pitch around and thrust back toward KSC until within gliding distance of the Shuttle Landing Facility.

STS-56 contingency landing sites are the Kennedy Space Center, White Sands Space Harbor, Zaragoza, Ben Guerir and Moron.

STS-56 SUMMARY TIMELINE

Blue/Red - Flight Day 1

Ascent
OMS-2
Remote Manipulator System checkout
Remote Manipulator System payload bay survey
Shuttle Amateur Radio Experiment set-up
HERCULES set-up
RME activation
Shuttle Solar Backscatter Ultraviolet activation

Red - Flight Day 2

Atmospheric Laboratory for Applications and Science activation
Commercial Materials Dispersion activation
Solar Ultraviolet Experiment activation

Blue - Flight Day 2

ATLAS 2 operations
SUVE operations

Red - Flight Day 3

ATLAS 2 operations
SUVE operations
Laser range finder checkout
HERCULES operations

Blue - Flight Day 3

ATLAS 2 operations
SUVE operations

Red - Flight Day 4

ATLAS 2 operations
SUVE operations
SPARTAN-201 checkout

Blue - Flight Day 4

SPARTAN-201 deploy
Separation burns
ATLAS 2 operations

Red Flight Day 5

ATLAS 2 operations
SUVE operations

Blue Flight Day 5

SPARTAN-201 stationkeeping
ATLAS 2 operations
SUVE operations

Red - Flight Day 6

ATLAS 2 operations
SUVE operations

Blue - Flight Day 6

SPARTAN-201 rendezvous
SPARTAN-201 grapple
SPARTAN-201 berth

Red - Flight Day 7

ATLAS 2 operations
SUVE operations

Blue - Flight Day 7

Flight Control Systems checkout
ATLAS 2 operations
SUVE operations

Red - Flight Day 8

Orbital Debris Radar Calibration System deploy
ATLAS 2 operations
HERCULES operations

Blue - Flight Day 8

ATLAS 2 operations
SUVE operations
RMS power down and berth
RME deactivation
SAREX deactivation

Red/Blue - Flight Day 9

ATLAS 2 deactivation
SSBUV deactivation
SUVE deactivation
Cabin stow
De-orbit preparations
De-orbit burn
Landing

STS-56 VEHICLE AND PAYLOAD WEIGHTS

	<u>Pounds</u>
Orbiter Landing Weight	206,532
Orbiter (Discovery) empty and 3 SSMEs	173,227
ATLAS 2	8,360
SPARTAN-201 (deployable)	2,842
SPARTAN-201 (support equipment)	2,425
SSBUV	733
SUVE	593
PARE	170
HERCULES	126
CMIX	71
SAREX-II	67
STL	58
CREAM	37
RME-III	7
Total Vehicle at SRB Ignition	4,500,837

ATLAS 2

ATLAS 2, the second in NASA's series of Atmospheric Laboratory for Applications and Science Spacelab missions, is the primary payload for the STS-56 flight. The Space Shuttle-borne remote sensing laboratory studies the sun's energy output and Earth's middle-atmosphere chemical makeup, and how these factors affect levels of ozone, which prevents much of the sun's harmful ultraviolet radiation from reaching the Earth's surface.

Ozone depletion has been a serious environmental concern since the 1970s. In the mid-1980s, British scientists observed significant ozone depletion of the Antarctic. Visual images of the concentrated, well-defined areas of depletion gave rise to the term "ozone hole," which has appeared over the Antarctic since at least 1979. Satellite observations since then have shown long-term ozone depletion occurring in the Southern and Northern Hemispheres.

Concerns over the possible effects of ozone depletion, increases in cataracts and skin cancer and possible damage to food crops, led to an international treaty to phase out the use of ozone-depleting chemicals. However, many questions about the exact mechanisms of ozone depletion remain unanswered. To help answer those questions, the ATLAS missions will gather data on atmospheric chemistry and on the sun's energy - key ingredients in the ozone cycle.

Ozone is created and destroyed by complex reactions involving ultraviolet radiation from the sun and gases in the middle atmosphere, between 10 and 50 miles (15 and 80 kilometers) above the Earth's surface. ATLAS 1, which flew in March 1992, established a voluminous baseline of atmospheric and solar data against which to measure future global change.

ATLAS 2 and subsequent missions will track subtle, year-to-year variations in solar activity and in atmospheric composition. ATLAS instruments are precisely calibrated before and after flight, so they also provide a valuable cross-check for data being gathered on a continuous basis by similar instruments aboard free-flying satellites.

The ATLAS series is a vital part of NASA's "Mission to Planet Earth," a long-term effort to study the Earth as a global environmental system. Mission to Planet Earth will observe and monitor the interaction of large environmental components (land, oceans/water/ice, atmosphere and the biosphere). Data gathered will be distributed to global change researchers worldwide, allowing them to better understand natural changes in the Earth and to differentiate natural change from human-induced change. Mission to Planet Earth research will help humans make informed decisions about protecting their environment.

Scientists from six nations are participating directly in the ATLAS 2 mission, underscoring the worldwide importance of atmospheric and solar research. In addition to the United States, investigators represent Belgium, Germany, France, The Netherlands and Switzerland.

ATLAS 2 Instruments

The Space Shuttle Discovery will carry the ATLAS 2 Spacelab into orbit for 8 days of remote sensing experiments. Six instruments are mounted in the orbiter's payload bay on a Spacelab pallet. The seventh is mounted in two canisters on the walls of the payload bay.

The open, U-shaped pallet is reusable Spacelab equipment provided by the European Space Agency in 1981 as its contribution to the Space Shuttle program. The instruments' power supply, command and data-handling system and temperature control system are housed in a pressurized container called an igloo (also standard Spacelab equipment) located in front of the pallet. These seven instruments form the core ATLAS payload which will fly aboard ATLAS 2 as well as ATLAS 3 scheduled for late 1994.

Atmospheric Science

- The Atmospheric Trace Molecule Spectroscopy (ATMOS) experiment identifies the distribution, by altitude, of 30 to 40 different gases between 6 and 85 miles (10 and 140 kilometers) above the Earth's surface.
- The Millimeter Wave Atmospheric Sounder (MAS) measures water vapor, ozone and chlorine monoxide (a key compound that contributes to ozone loss), as well as temperature and pressure in the middle atmosphere.
- The Shuttle Solar Backscatter Ultraviolet (SSBUV) spectrometer, mounted on the walls of the payload bay, measures ozone concentrations by comparing solar ultraviolet radiation with that scattered back from the Earth's atmosphere.

Solar Science

- The Solar Spectrum Measurement (SOLSPEC) instrument studies the distribution of solar energy by wavelength, from infrared through ultraviolet.
- The Solar Ultraviolet Irradiance Monitor (SUSIM) concentrates on the sun's ultraviolet radiation, which undergoes wider variations than other wavelengths.
- The Active Cavity Radiometer (ACR) and the Solar Constant (SOLCON) experiments each make extremely precise, independent measurements of the total energy Earth receives from the sun.

The steep, 57-degree Shuttle's orbit inclination will take it over points as far north as Juneau, Alaska, and as far south as Tierra del Fuego, Argentina -- allowing readings to be made over virtually the entire globe.

On ATLAS 2, the Atmospheric Trace Molecule Spectroscopy experiment, which made most of its measurements in the Southern Hemisphere during ATLAS 1, will focus on the Northern Hemisphere. To view orbital "sunrises" at high latitudes, a night launch is required.

ATLAS 2 Investigations

Investigation	Spectral Range	Selected Objectives	Principal Investigator
Atmospheric Science:			
ATMOS	Infrared	Water vapor, ozone, methane, chlorine and nitrogen compounds, chlorofluorocarbons, others	M. Gunson, NASA Jet Propulsion Laboratory, United States
MAS	Microwave	Temperature, pressure, ozone, chlorine monoxide, water vapor	G. Hartmann, Max Planck Institute for Aeronomy, Germany
SSBUV	Near Ultraviolet	Ozone	Se. Hilsenrath, NASA Goddard Space Flight Center, United States
Solar Science:			
ACRIM	Total Energy	Solar constant	R. Willson, NASA Jet Propulsion Laboratory, United States
SOLCON	Total Energy	Solar constant	D. Crommelynck, Belgian Royal Institute for Meteorology, Belgium
SOLSPEC	Infrared to Ultraviolet	Solar spectrum	G. Thuillier, Aeronomy Service for the National Center for Scientific Research, France
SUSIM	Ultraviolet	Solar spectrum	G. Brueckner, Naval Research Laboratory, United States

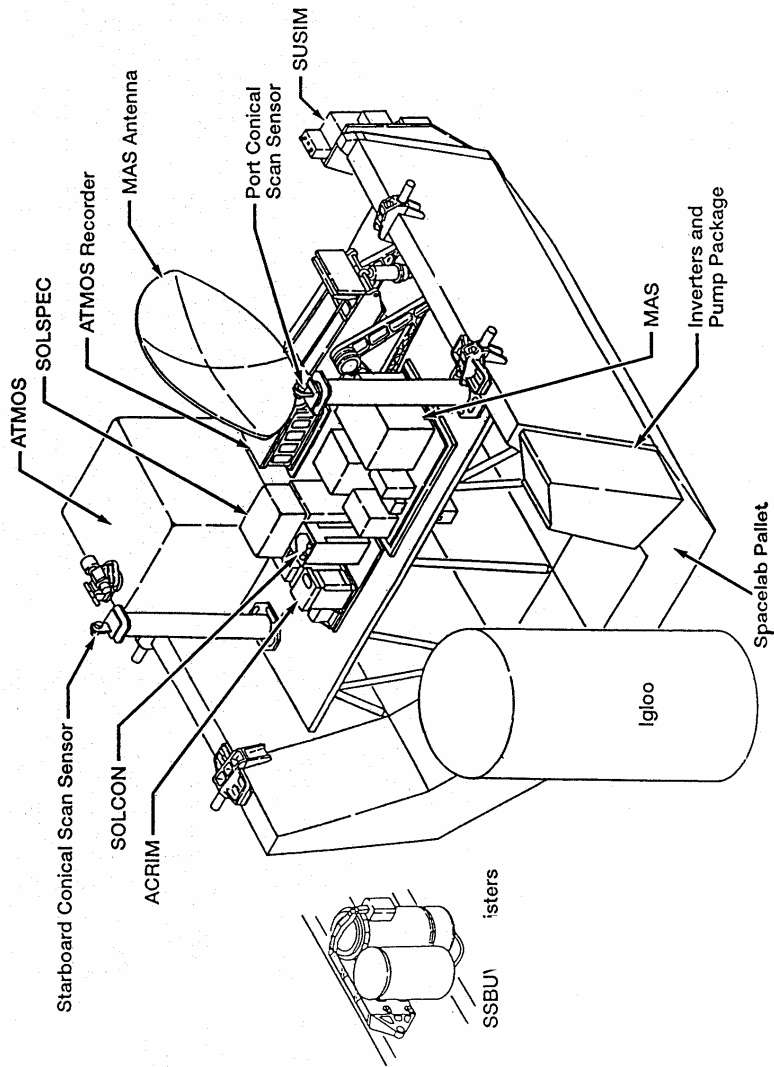

ATLAS 2 in Cargo Bay

Space Remote Sounding Techniques

Nadir Sounding (SSBUV)

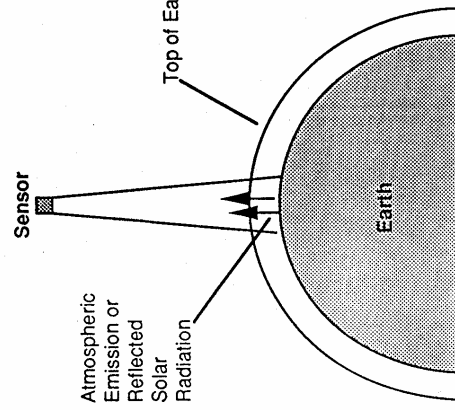

Atmospheric Limb Sounding (MAS)

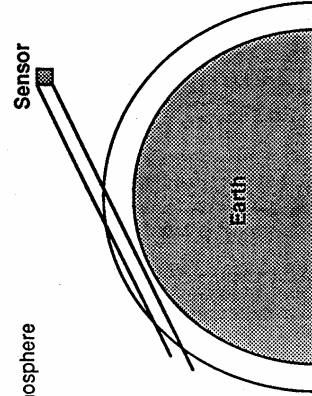

Solar Occultation (ATMOS)

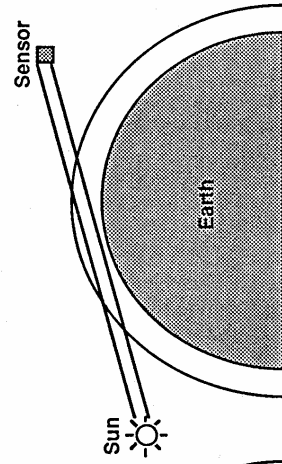

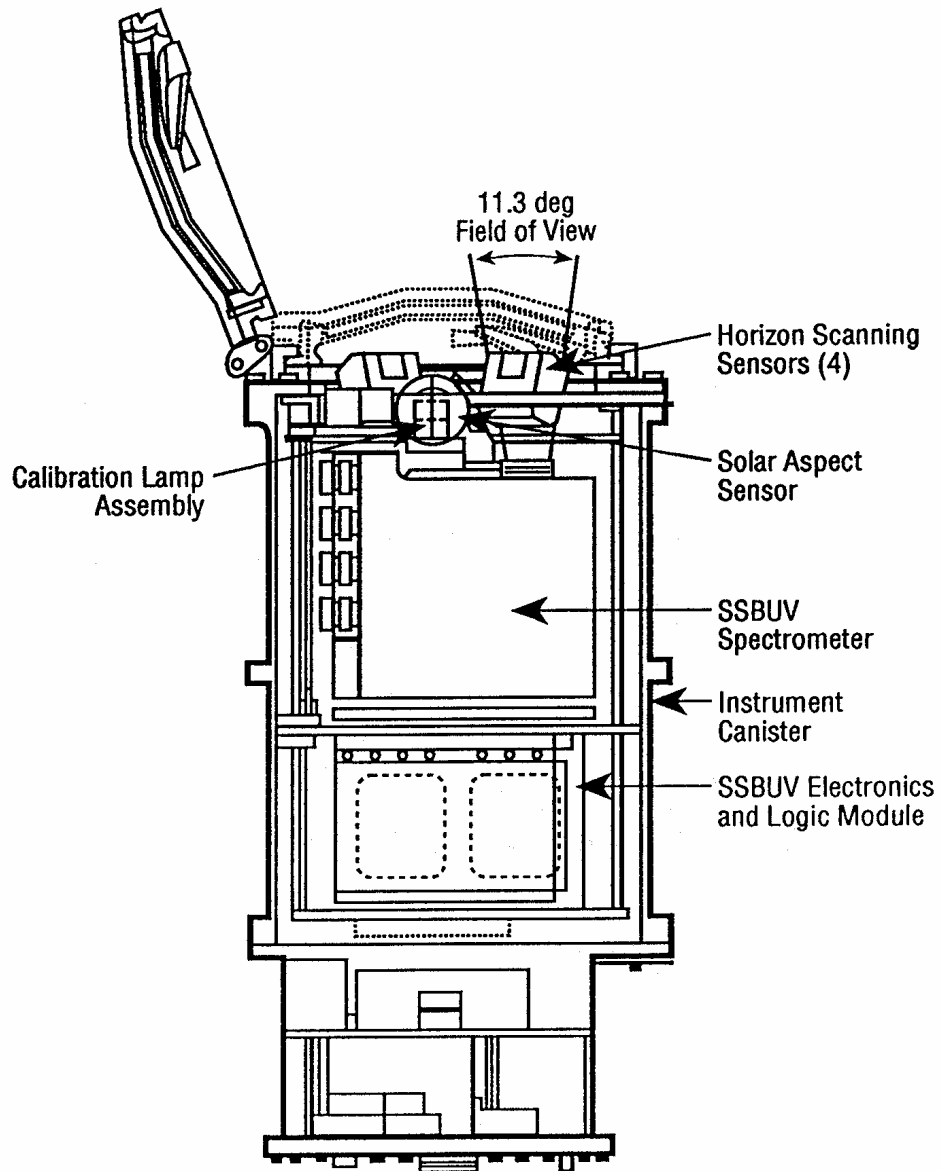

SSBUV

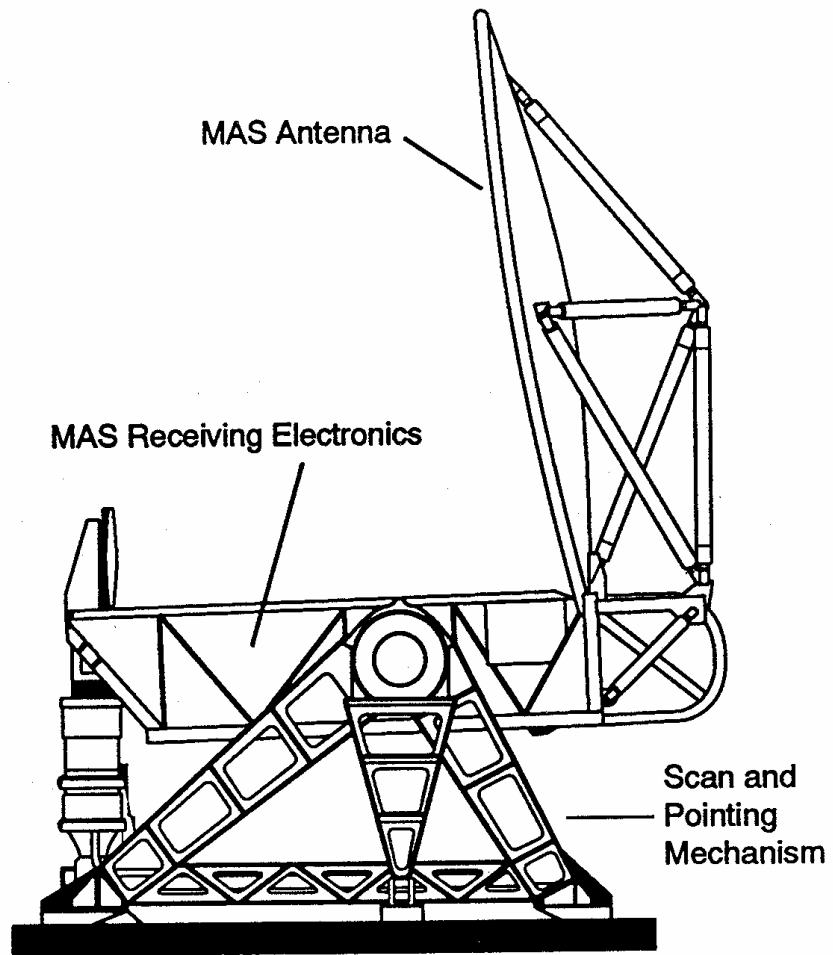

Millimeter-Wave Atmospheric Sounder (MAS)

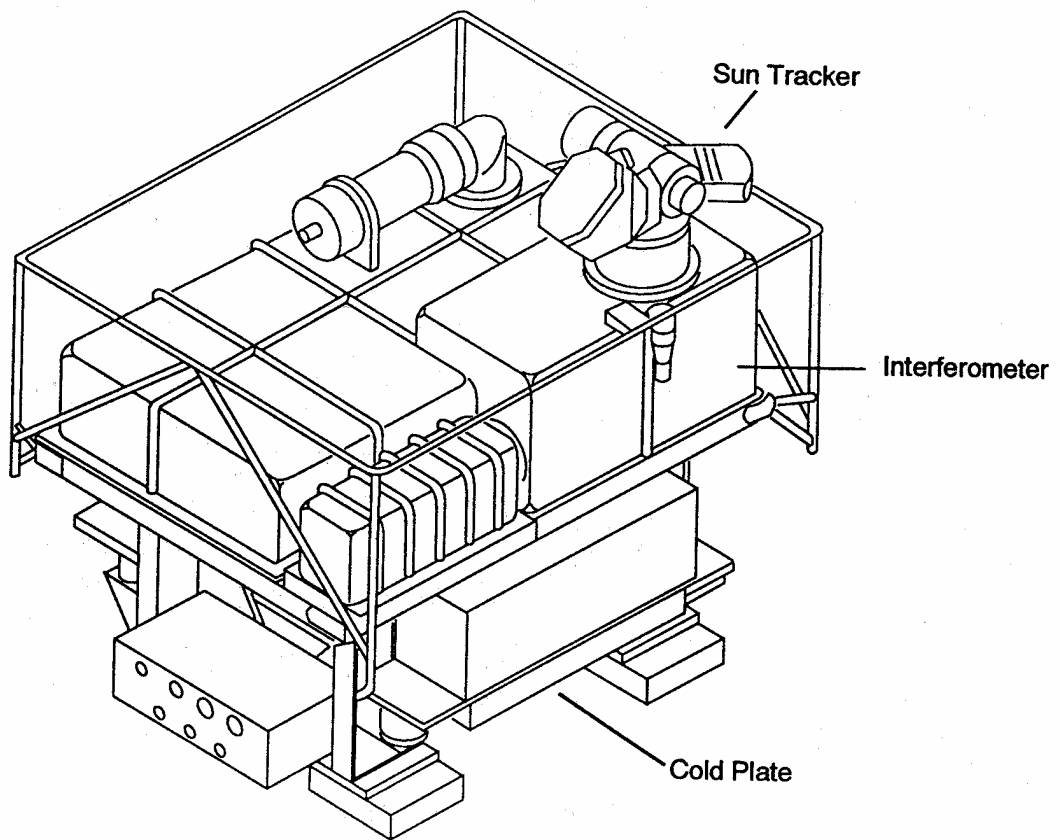

Atmospheric Trace Molecule Spectroscopy (ATMOS)

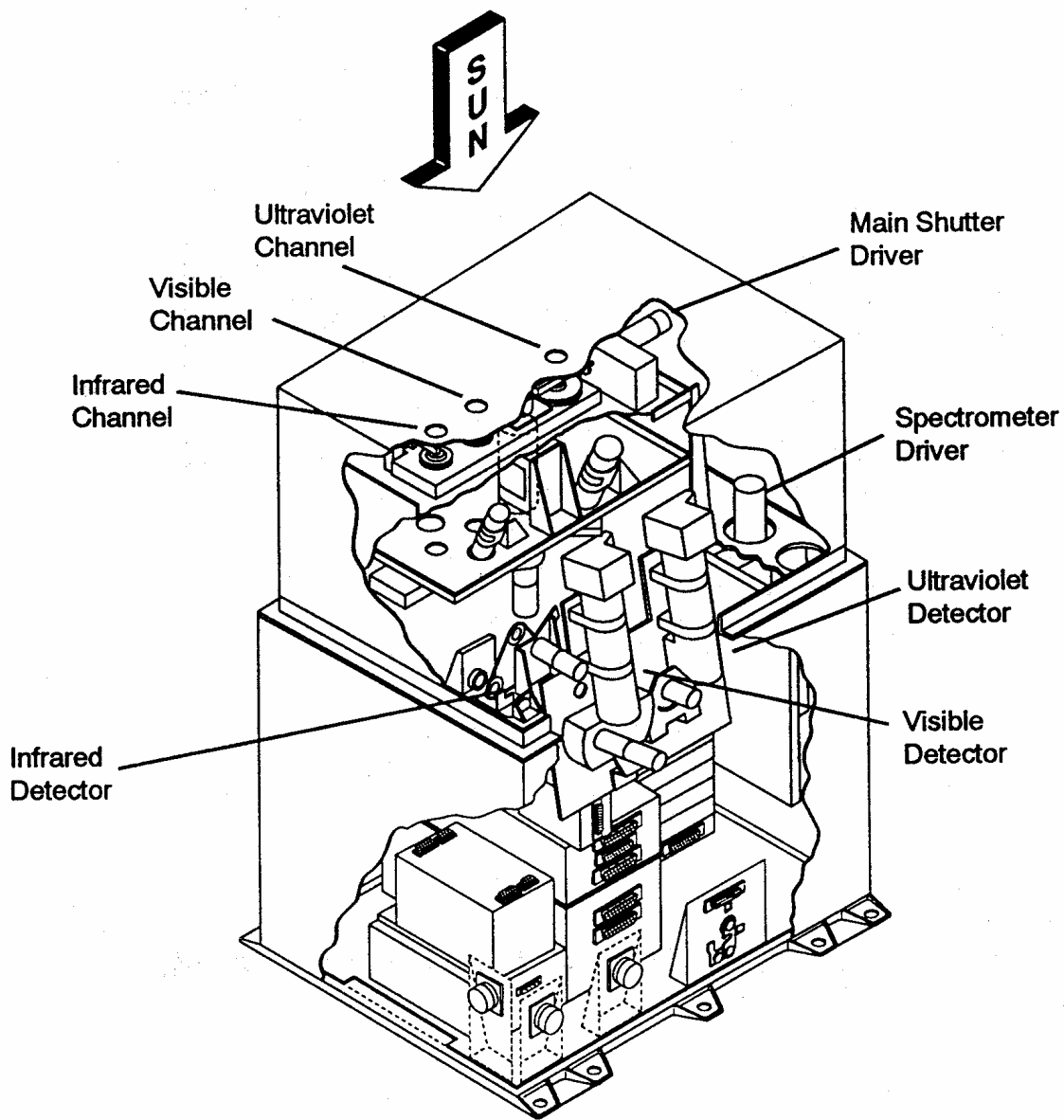

Solar Spectrum Measurement (SOLSPEC)

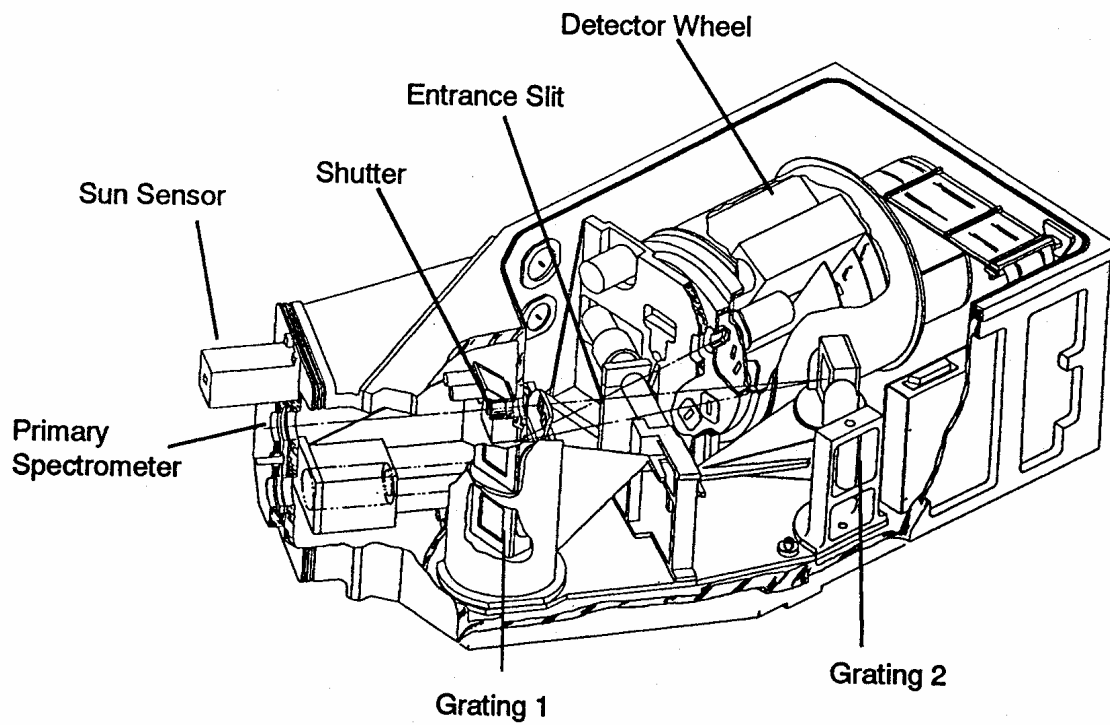

Solar Ultraviolet Irradiance Monitor (SUSIM)

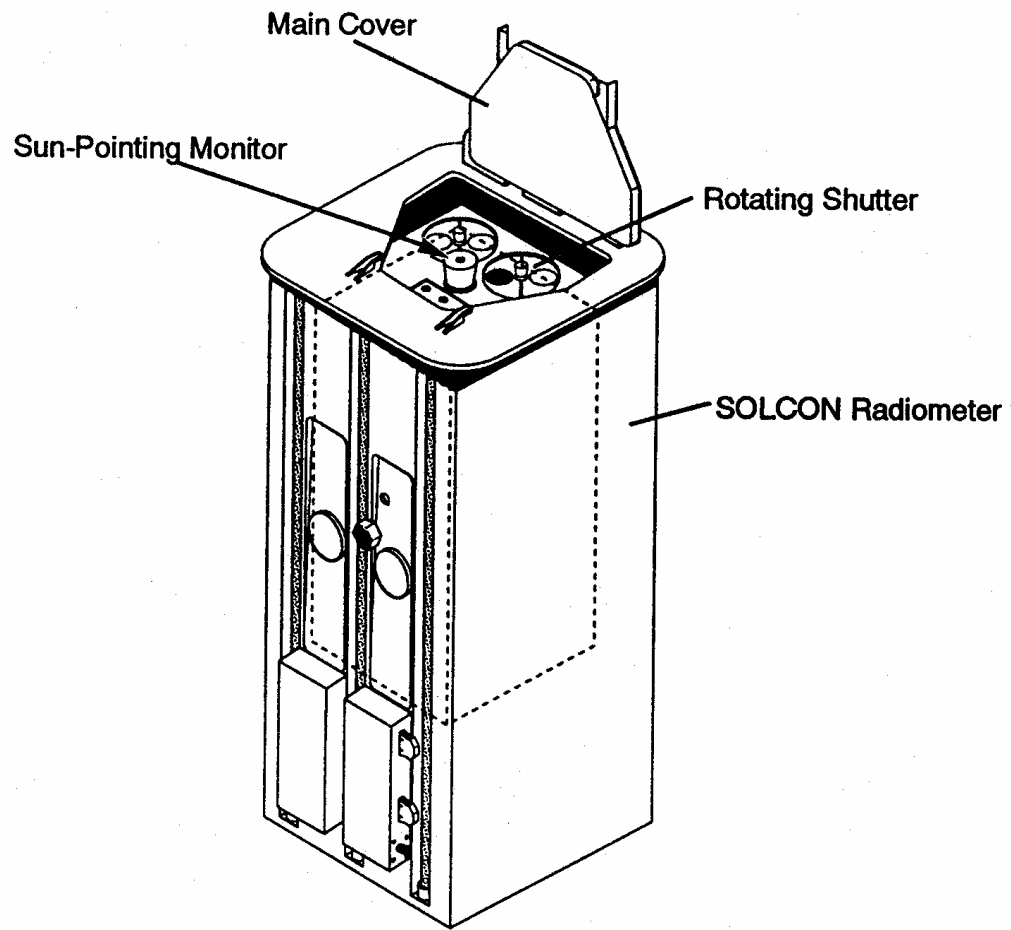

Measurement of the Solar Constant (SOLCON)

ATLAS Missions and the Shuttle

The Space Shuttle is the ideal platform for NASA's remote-sensing atmospheric laboratory. The flight crew can maneuver the orbiter so the instruments in the bay point precisely toward the atmosphere, the sun or the Earth's surface as necessary for scheduled observations. The Shuttle's generous payload capacity and power supply allow a diverse assembly of large instruments to make simultaneous remote observations. The Shuttle-borne ATLAS instruments make more detailed measurements than similar instruments now flying aboard satellites.

Because the Shuttle returns the laboratory to Earth after each flight, it also has the advantage of assured calibration. ATLAS instruments are calibrated to a high level of accuracy prior to launch and shortly after the Shuttle lands, they are recalibrated to ensure their sensitive measurements remain accurate.

ATLAS missions take a "snapshot" of the atmosphere for about a week at a time. However, atmospheric and solar measurements are being made continuously by instruments aboard free-flying satellites, such as the Upper Atmosphere Research Satellite launched in September 1991 and various National Oceanic and Atmospheric Administration (NOAA) satellites.

Extended exposure to the harsh environment of space, especially to ultraviolet radiation, can degrade the accuracy of those instruments. By comparing data from the ATLAS instruments to their sister experiments aboard the free-flyers, scientists can correct for drift in the satellite instruments and have a high level of confidence in the accuracy of their measurements.

Science Operations Plan

The ATLAS 2 science operations plan calls for periods of atmospheric data gathering interspersed with orbits dedicated to solar observations.

During their designated orbits, the instruments investigating middle atmospheric phenomena will operate almost continuously. ATMOS will take solar radiation absorption readings during each orbital sunrise and sunset. (An orbital "day," with a sunrise and sunset, occurs approximately every 90 minutes during flight.)

MAS will measure microwave emissions from Earth's limb throughout each orbit, and SSBUV will make its measurements of backscattered ultraviolet radiation in the daylight portion of these orbits. The ATMOS and MAS instruments will be inactive during solar observation periods.

Solar observations are scheduled early in the flight, on two occasions in the middle of the mission and during the last full day of science operations. At these times, ACRIM and SOLCON will measure total solar irradiance. SUSIM and SOLSPEC will make solar spectral measurements, and SSBUV will gather its data on solar ultraviolet radiation. The Shuttle orbit allows numerous correlative measurements with UARS and the NOAA satellites. Similar instruments aboard these spacecraft will make independent measurements of the same regions of the atmosphere at about the same time. Data gathered during these opportunities will be compared to check the accuracy of readings by the satellite instruments.

The ATLAS experiments will gather data from about 4 hours after launch until approximately 12 hours before landing. ATLAS operations will be suspended temporarily during deployment and retrieval of the Shuttle Pointed Autonomous Research Tool for Astronomy (SPARTAN) free flyer, since Shuttle maneuvers required for those activities will prevent proper pointing of the ATLAS instruments.

The ATLAS 2 Team

The ATLAS program is sponsored by NASA's Office of Space Science and Applications and is directed by the Earth Science and Applications Division and the Flight Systems Division, located in Washington, DC.

The mission management and control of each ATLAS flight is the responsibility of NASA's Marshall Space Flight Center, Huntsville, Ala. The mission manager directs a civil service and contractor team effort to match science objectives with Shuttle-Spacelab resources so each flight is fine-tuned to gather the maximum amount of science information. This effort includes preparing a minute-by-minute schedule, called a timeline, that combines crew activities, experiment requirements, Spacelab resources and Shuttle maneuvers into an efficient operating plan.

Principal investigators of the individual experiments form an Investigator Working Group that meets regularly before the mission to advise the mission manager's team on science-related issues and payload operations. The working group is chaired by the mission scientist, a member of the mission manager's team.

During the mission, the management and science teams control the ATLAS instruments around the clock from NASA's Spacelab Mission Operations Control facility at the Marshall center. The facility contains banks of computers, monitors and communication consoles which enable the ground team to monitor the payload, collect data, send direct commands to the experiments and communicate with the Shuttle crew. During the mission the science teams meet twice daily as a Science Operations Planning Group to evaluate science activities, solve problems and recommend ways to take full advantage of any unplanned opportunities.

The two European solar experiments, SOLCON and SOLSPEC, will be jointly operated from the NASA control center in Huntsville and from a control center at the Institut Royal Meteorologique de Belgique, Brussels, Belgium, during portions of the ATLAS 2 mission.

Most of the ATLAS instruments operate automatically, commanded by the Spacelab computers or by the science teams in Huntsville. However, crew members can use keyboards to enter observation sequences or commands if necessary. Another crew member on each team is part of the orbiter crew and is responsible for maneuvering the Shuttle when an instrument requires precise pointing or must be operated in a specific attitude.

SHUTTLE POINT AUTONOMOUS RESEARCH TOOL FOR ASTRONOMY-201 (SPARTAN-201)

Spartan-201 is a free-flying payload that will study the velocity and acceleration of the solar wind and observe aspects of the sun's corona. Results will help scientists understand the physics of the sun's corona and the solar wind.

Spartan is deployed by the Shuttle and retrieved on the same mission. While overboard it is completely autonomous, providing its own battery power, pointing system and data recorder as it executes a pre-programmed science mission. The Spartan carrier can support a variety of scientific studies and serve as a test bed for technology development.

The Space Shuttle offers easy access to a variety of systems that can conduct scientific investigations from above the Earth's atmosphere. Spartan is one of those systems, providing a capability between small attached payloads and the large, long duration, free-flying satellites.

Spartan has evolved using sounding rocket class instruments to perform the scientific studies. This system provides a significant increase in observing time compared to sounding rockets. The simple and efficient Spartan carriers are reusable and can accommodate a variety of scientific instruments for a relatively low cost-per-flight.

Spartan-201 Science

Spartan-201 will look for evidence to explain how the solar wind is generated by the sun. Electrons, heavy protons and heavy ions are constantly ejected from the outer layers of the solar atmosphere. The Earth encounters this material continually as it orbits the sun. The solar wind fills interplanetary space and sweeps by the Earth at almost 1 million miles per hour (400 km/sec). It often blows in gusts and frequently disrupts navigation, communications and electric power distribution systems on Earth.

The solar wind originates in the corona, the outermost atmosphere of the sun. Two telescopes for studying the corona comprise the science payload of Spartan 201. One telescope, the White Light Coronagraph (WLC), will measure the density distribution of electrons making up the corona. The other telescope, the Ultraviolet Coronal Spectrometer (UVCS), will investigate the temperatures and distributions of protons and hydrogen atoms through the same layers of the corona. Ultraviolet radiation, which is absorbed by the Earth's atmosphere, cannot be observed from the ground.

A comparison of the white light and ultraviolet data sets will, for the first time, allow scientists to measure the electron and proton temperatures and densities in the solar corona. This also will yield new evidence on large flows of material in the corona and allow scientists to test specific theories on how the corona is heated to its million-degree temperature.

The UVCS was built by scientists from the Smithsonian Astrophysical Observatory, Harvard University, Cambridge, Mass. The WLC was developed by the High Altitude Observatory of the National Center for Atmospheric Research in Boulder, Colo., and has been transferred to NASA's Goddard Space Flight Center (GSFC), Greenbelt, Md.

Deployment

The dual-telescope payload is mounted on the Spartan carrier. On orbit, a crew member will use the Remote Manipulator System to lift the Spartan from its rack and release it over the side of the Shuttle. Spartan will operate independently, turning and pointing at the sun, leaving the orbiter free for other activities.

Additionally, by maintaining its distance from the Shuttle, the Spartan is able to stay clear of any contamination which might be generated by Shuttle thruster firings.

Spartan-201 will be deployed on the third day of STS-56. Discovery will perform a series of engine firings that will put Discovery at a point about 20 nautical miles (37 km) behind the satellite.

For between 6 and 40 hours, Spartan-201's instruments will observe the sun. At about 4 hours prior to the scheduled retrieval time, Discovery will close on Spartan-201, eventually passing directly below it before Commander Steve Oswald manually flies Discovery the final few hundred feet to allow the satellite to be grasped by the robot arm. Once caught by the arm, Spartan-201 will be stowed back in the cargo bay to be returned to Earth.

Spartan is designed to be self-operating as much as possible, and the crew will have no interaction with the satellite other than releasing it and recapturing it.

History

The Spartan Program was conceived in the mid-1970s and developed by GSFC and the U.S. Naval Research Laboratory to extend the capabilities of sounding rocket class science experiments by making use of the Space Shuttle.

The telescopes on Spartan-201 have flown previously on sounding rockets. In June 1985, a Spartan mission carried an X-Ray telescope. Another mission, Spartan Halley, was on board STS-51L and was destroyed in the Challenger accident.

The Spartan program is managed by GSFC for the Office of Space Science and Applications, Washington, DC. The Spartan Project Manager is Frank Collins and the Mission Manager is Jack Pownell, both of Goddard's Special Payloads Division. The Principal Investigator is Dick Fisher, also of GSFC.

SOLAR ULTRAVIOLET EXPERIMENT (SUVE)

SUVE is a Colorado Space Grant Consortium project that will study the extreme ultraviolet solar radiation as it affects the Earth's ionosphere. The payload is housed in a single Get-Away Special (GAS) canister, developed by NASA's Goddard Space Flight Center to provide low-cost access to space for high school and college students as well as other small research groups.

The SUVE payload is designed, managed and built entirely by students at the University of Colorado. Graduate and undergraduate students from aerospace, mechanical and electrical engineering as well as physics and other scientific disciplines have been involved since the project's inception. From project management to detailed performance analyses, the SUVE project is entirely student run.

The Colorado Space Grant Consortium is a group of 14 Colorado colleges and universities funded by NASA for the express purpose of educating students in the science and engineering aspects of exploring and working in outer space. The programs range from introductory education for K-12 students, to design and development of actual space projects for undergraduate and graduate students.

STS-56 EDUCATION ACTIVITIES

Atmospheric Detectives, ATLAS 2 Teacher's Guide

A teacher's guide entitled, Atmospheric Detectives, has been developed for use with middle school students to complement and teach the science objectives of the ATLAS 2 mission.

Atmospheric Detectives blends lessons in mathematics, chemistry, physics and Earth sciences with problem solving exercises in an attempt to nurture students' natural curiosity and excitement about science and technology. The ATLAS 2 teacher's guide probes the connection between the activities of scientists and researchers and the observable world of weather and climate.

Students briefly will examine the findings of the ATLAS-1 flight linking that mission with the science goals of ATLAS 2 and future flights. As scientists, students will explore how solar and atmospheric changes might affect climate, specifically looking at solar output, wind patterns and water vapor.

Students will explore how ATLAS 2 investigators measure the effects on climate using remote-sensing techniques of spectrometry and limb sounding as well as ground truth studies and exercises emphasizing the importance of mathematics and precise measurement.

HAND-HELD, EARTH-ORIENTED, REAL-TIME, COOPERATIVE, USER- FRIENDLY, LOCATION-TARGETING AND ENVIRONMENTAL SYSTEM (HERCULES)

Naval Research Laboratory (NRL) scientists will again test a system developed to allow a Shuttle astronaut in space to point a camera at an interesting feature on Earth, record the image and determine the latitude and longitude of the feature.

Called HERCULES, the system includes a modified Nikon camera and a geolocation device which determines in real-time the latitude and longitude of Earth images.

HERCULES will provide a valuable Earth observation system for military, environmental, oceanographic and meteorological applications. HERCULES, flown once before in December 1992 on Space Shuttle flight STS-53, is being integrated and flown on the Space Shuttle under the direction of the Department of Defense's Space Test Program.

Images and geolocation data taken during the STS-53 mission still are being analyzed, but geolocation accuracies are about 3 nautical miles. An additional system feature that will be used during STS-56 is the ability to transmit images and geolocation data to the Mission Control Center for analysis while the mission is in progress.

The project is a joint Navy, Army, NASA effort. Scientists at NRL's Naval Center for Space Technology developed the HERCULES Attitude Processor (HAP) and the alignment, geolocation and human interface software to perform the geolocation. The other components in the system are a NASA- built Electronic Still Camera (ESC) that stores images in a digital form and a modified Nikon F-4 and Honeywell ring-laser gyro.

On board the Shuttle, the astronaut will start up the system by pointing the camera, with the attached gyro, at two known stars to obtain a bearing. The astronaut then "shoots" images by pointing the camera at the Earth and snapping the shutter.

The camera communicates with HAP, which processes the data from the gyro and determines its absolute orientation in space. Then, the HAP passes this pointing information to the NRL software running on a NASA-modified GRID portable computer. The computer then determines the longitude and latitude of the image.

The geolocation information is sent back to the camera by the HAP, where it is appended to the image data. The astronaut can view the image on the Shuttle and downlink it to Earth. The image and geolocation data are also stored in the ESC system for post-mission analysis."

The system is a significant improvement over its predecessor called L- cubed. Under the L-cubed system, the astronauts had to take multiple images of the same target while simultaneously keeping the edge of the Earth in view, which limited image magnification.

With HERCULES, the astronaut only needs to look at the point of interest, allowing the use of many different camera lenses. In the daytime, the system uses any Nikon-compatible lens. At night, it operates with an image intensifier developed by the Army's Night Vision Laboratory. At any magnification, images with no distinguishing demographic features can be captured and geolocated. HERCULES captures images digitally, which allows computer analysis and data dissemination, an improvement over the film-based L-cubed system.

NRL scientists already are exploring enhancements to HERCULES. Incorporating Global Positioning System (GPS) hardware into HERCULES would provide a geolocation accuracy better than 1 nautical mile, and adding a gimbal system would allow the system to automatically track points on Earth. One modification to HERCULES being considered is providing orbiter power to the ESC components rather than using the battery packs utilized on STS-53. By not having to replace the battery packs, the astronaut will have more opportunities to test the system.

HERCULES

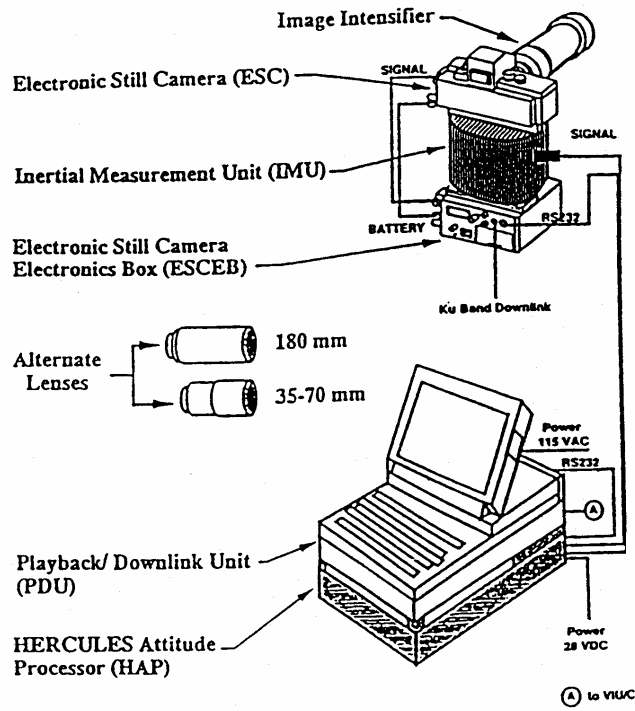

HERCULES Configuration B

RADIATION MONITORING EQUIPMENT-III (RME-III)

The RME-III instrument measures the exposure of ionizing radiation on the Space Shuttle. RME-III displays the dose rate and total accumulated radiation dose to the astronaut operator. Simultaneously RME-III registers the number of radiation interactions and dose accumulated at 10 second intervals and stores the data in an internal memory for follow-up analysis upon return to Earth.

The radiation detector used in RME-III is a spatial ionization chamber called a tissue equivalent proportional counter (TEPC). It effectively simulates a target size of a few microns of tissue, the dimensions of a typical human cell. For this reason, TEPC-based instruments such as the RME-III are called micro-dosimeter instruments.

RME stands for Radiation Monitoring Equipment, the name given to prototype dosimeter instruments flown on the Space Shuttle prior to 1986. The RME-III has successfully flown on 13 Space Shuttle missions since STS- 26.

RME is being integrated and flown on this mission under the direction of the Defense Department's Space Test Program. It has been flown in conjunction with other radiation experiments, such as the Cosmic Radiation Effects and Activation Monitor and Shuttle Activation Monitor. It is anticipated that RME will be flown on several future Space Shuttle missions.

The data obtained from RME-III is archived and is being used to update and refine models of the space radiation environment in low Earth orbit. This will assist space mission planners to more accurately assess risk and safety factors in future long-term space missions, such as Space Station Freedom.

Next generation instruments similar to the RME-III will be flown on Space Station Freedom and on future manned and unmanned missions to the Moon, Mars and beyond. RME-III also is being used to measure radiation exposure in high altitude aircraft, such as the Concorde.

COSMIC RADIATION EFFECTS AND ACTIVATION MONITOR (CREAM)

The Cosmic Radiation Effects and Activation Monitor (CREAM) experiment on STS-56 is designed to collect data on cosmic ray energy loss spectra, neutron fluxes and induced radioactivity. The data will be collected by active and passive monitors placed at specific locations throughout the orbiter's cabin.

The active monitor will obtain real-time spectral data while the passive monitors will obtain data during the entire mission to be analyzed after the flight. The flight hardware contains the active cosmic ray monitor, a passive sodium iodide detector and up to five passive detector packages. All hardware fits in one locker on Discovery's middeck.

Once in orbit, a crew member will be available at regular intervals to monitor the payload/experiment. CREAM is a Department of Defense experiment and is flown under the direction of DOD's Space Test Program.

AIR FORCE MAUI OPTICAL SITE (AMOS)

The AMOS is an electro-optical facility located on the Hawaiian island of Maui. The facility tracks the orbiter as it flies over the area and records signatures from thruster firings, water dumps or the phenomenon of "shuttle glow."

The Shuttle glow phenomenon around the orbiter is a well- documented glowing effect caused by the interaction of atomic oxygen with the spacecraft. The information obtained is used to calibrate the infrared and optical sensors at the facility. No hardware onboard the Shuttle is needed for this experiment.

CREAM CONFIGURATION

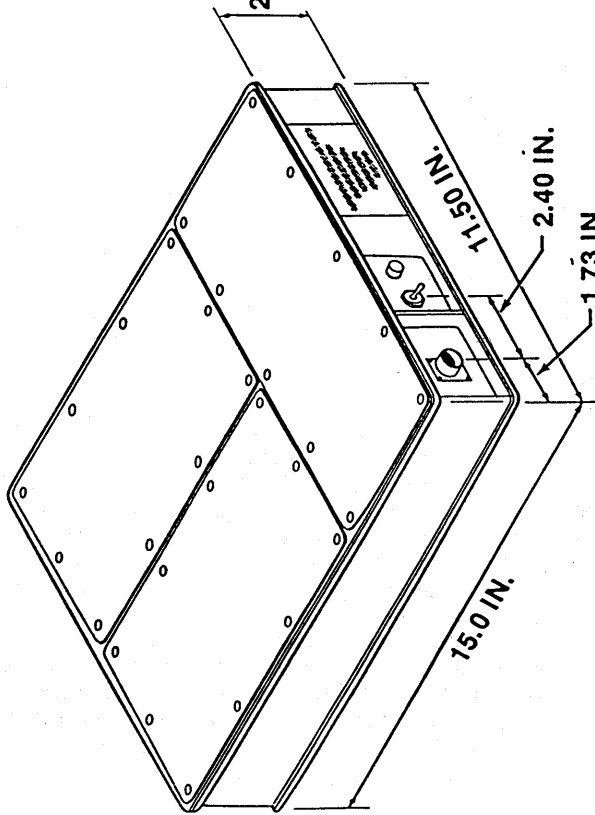

ACTIVE MONITOR

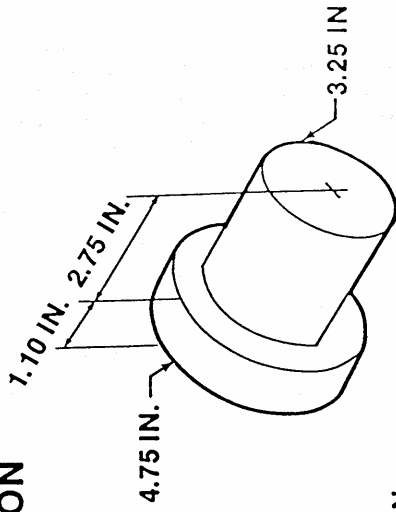

**SODIUM IODIDE CRYSTAL
PASSIVE DETECTOR**

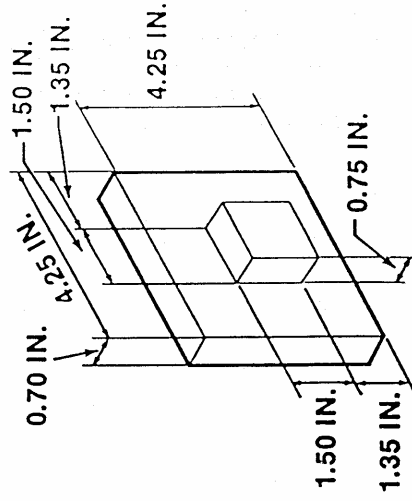

PASSIVE DOSIMETRY PACKAGE

SHUTTLE AMATEUR RADIO EXPERIMENT-II

The Shuttle Amateur Radio Experiment-II (SAREX-II) provides public participation in the space program, supports educational initiatives and demonstrates the effectiveness of making contact between the Space Shuttle and amateur "ham" radio stations on the ground.

SAREX-II was last flown aboard STS-55 and during that flight, there were dozens of voice contacts with ham stations at schools around the world and hundreds of contacts with individual ham operators. On STS-56, crew members Ken Cameron, call sign N5AWP, Ken Cockrell, call sign KB5UAH, Mike Foale, call sign KB5UAC, and Ellen Ochoa, call sign KB5TZZ, will use SAREX-II as a secondary payload.

Operating times for school contacts are planned into the crew's activities. The school contacts generate interest in science as students talk directly with the astronauts. There will be voice contacts with the general ham community as time permits. Short-wave listeners worldwide also may listen in. When the crew is not available, SAREX-II will be in an automated digital response mode.

SAREX-II will include VHF FM voice, VHF packet, VHF slow scan television and UHF fast scan television. The Space Shuttle has the built-in ability to downlink television on any mission, but only SAREX-II has the ability to uplink television to the crew. During STS-50, fast scan television uplink was used to send home videos of the crew members' families to the spacecraft, a specially recorded message from Jay Leno and a specially recorded Houston television sportscast.

The primary voice and packet frequencies that SAREX-II uses are 145.55 MHz downlink and 144.95 MHz uplink. The 600 kHz spacing in the transmit and receive frequency pair is compatible with amateur VHF equipment. Since STS-56 is a high inclination flight, SAREX-II may be heard from northern Canada to southern Australia and all points in between when the Shuttle is crossing overhead.

SAREX has previously flown on STS-9, STS-51F, STS-35, STS-37, STS- 45, STS-50, STS-47 and STS-55. SAREX is a joint effort of NASA, the American Radio Relay League (ARRL), the Amateur Radio Satellite Corp. (AMSAT), and the Johnson Space Center's Amateur Radio Club. Information about orbital elements, contact times, frequencies and crew operating schedules will be made available during the mission by these agencies and by amateur radio clubs at some other NASA centers.

Hams from the Johnson Space Center club, W5RRR, will be operating on amateur short-wave frequencies, and the ARRL station, W1AW, will include SAREX information in its regular voice and teletype bulletins. The amateur radio station at the Goddard Space Flight Center, WA3NAN, in Greenbelt, Md., will operate around the clock during the mission, providing information and re-transmitting live Shuttle air-to-ground audio.

The Johnson Space Center Public Affairs Office man a SAREX information desk during the mission, and mission information also will be available on the dial-up computer bulletin board (BBS) at JSC.

SAREX Frequencies	Shuttle Transmitting Frequency	Shuttle Receiving Frequency
U.S., Africa, South America, and Asia	145.55 MHz	144.95 MHz
	145.55	144.97
	145.55	144.91
Europe	145.55	144.95
	145.55	144.75
	145.55	144.70

GSFC Amateur Radio Club
(WA3NAN) planned HF operating frequencies

3.860 MHz	7.185 MHz
14.295 MHz	21.395 MHz
28.395 MHz	

To connect to the JSC Computer Bulletin Board, BBS, (8 N 1 1200 baud): dial 713/483-2500 then type 62511.

COMMERCIAL MDA ITA EXPERIMENTS

More than 30 investigations will be conducted aboard Space Shuttle Discovery to obtain information on how microgravity can aid research in drug development and delivery, biotechnology, basic cell biology, protein and inorganic crystal growth, bone and invertebrate development, immune deficiencies, manufacturing processes and fluid sciences.

The experiments represent the second flight of the Commercial MDA ITA Experiments (CMIX-2) payload and should provide scientists and engineers with some 400 data points from which they can focus and expand their research in microgravity.

NASA's Office of Advanced Concepts and Technology is sponsoring CMIX- 2, with program management provided by the Consortium for Materials Development in Space (CMDS), a NASA Center for the Commercial Development of Space (CCDS), based at the University of Alabama in Huntsville (UAH).

CMIX-2 is part of an innovative program between the UAH CMDS and ITA, Inc., Exton, Penn., to provide the CCDS community with increased access to space. The program will use ITA-developed hardware on a total of five Shuttle missions. In exchange for the flight opportunities, ITA is providing 50 percent of its hardware capacity to the UAH CMDS.

The CMIX-2 hardware consists of four Materials Dispersion Apparatus (MDA) Minilabs, two of which will contain experiments developed by the UAH CMDS and its industry affiliates. The other two, commercially marketed by ITA, will contain experiments developed by ITA's customers, which include U.S. biomedical technology and biomaterials companies, international users and university research institutions.

A percentage of ITA's MDA capacity will include high school student experiments as part of the company's Student Space Education Program to increase awareness and interest in science and space technology.

The MDA Minilab is a brick-sized, automated device capable of bringing into contact and mixing up to 100 separate samples of multiple fluids and/or solids at precisely timed intervals. The MDA, which is housed in a Commercial Refrigerator/Incubator Module (CRIM), uses four techniques for sample contact/mixing, including liquid-to-liquid diffusion, vapor diffusion, magnetic mixing and reverse gradient diffusion.

In addition, live cell investigations will be conducted in ten Bioprocessing Modules (BPM), which contain 60 to 100 times more fluid volume than the MDAs. The BPMs will be flown "piggy back" using available space in the CRIM, between the MDAs.

The MDAs and BPMs each have a specific advantage to the research being conducted on this flight. The MDAs can process a number of experiments using small volumes (0.2-0.5 milliliters) of sample materials. On the other hand each BPM can process only one or two experiments using a large volume (4-6 milliliters) of sample materials.

Experiment Descriptions

Experiments developed by the UAH CMDS and its affiliates include:

- **Bone Cell Differentiation (MDA):** Mouse bone cells will be evaluated on how well they grow and produce collagen in microgravity. Information from this experiment will contribute to a database on potential areas for drug treatment of osteoporosis. Potential commercial applications (3-10 years) include developing ways to enhance bone cell growth and prevent bone deterioration in astronauts and the elderly.

- Immune Cell Response (MDA): This experiment will obtain information on why some cells are more sensitive to microgravity than others. Once this is understood, techniques may be developed to stimulate immune system cells for use in treating immune suppressed patients and in developing and testing drugs to reduce some of the undesirable effects of microgravity.
- Diatoms (MDA): Minute plant cells (diatoms) encased in a silicone coating can be used to generate oxygen. This experiment will collect information on how microgravity affects these one-celled plants to determine if they can be used commercially to regenerate oxygen.
- Mouse Bone Marrow Cells (MDA): This experiment will obtain information on whether microgravity can enhance expansion of desirable cells by manipulating them with growth factors. Potential applications include bone marrow transplants and reconstituting the immune system after radiation therapy and chemotherapy treatments for leukemia, lymphoma and breast cancers.
- Nerve/Muscle Cell Interactions: Using frog cells, this experiment will study how microgravity affects the development of nerve cell communication which is essential for brain function. Results from this experiment may be relevant to the ability of higher organisms to undergo normal brain development in space. Information from this experiment will increase a database on nerve cell development in space, which will help to identify future potential commercial applications.
- Phagocytosis (MDA): To fight infection, one of the body's defenses is to rid itself of invading organisms, such as bacteria, by the process of phagocytosis (a means by which certain cells engulf and destroy foreign materials). This experiment will evaluate the phagocytic function of certain cells in microgravity. The expected long-range benefit is a better understanding of the behavior of these disease-fighting cells.
- Other experiments conducted in the MDA will evaluate fluids mixing, invertebrate and bone development, virus sub-unit assembly and collagen self-assembly, and formation of drug encapsulated liposomes. Commercial applications of these experiments include developing a database for potential commercial processes and services, which use individual cells to determine the effects of microgravity and to develop and test drugs in space. As the database on cell response and control is enlarged, growth of commercial applications can be expected.
- Live Cell Investigations (BPMs): Experiments conducted in the BPMs are designed to gain information on how cells of the human immune system may be induced to grow when exposed to certain compounds. Once scientists discover how cells respond to these compounds in microgravity, techniques may be developed to select for certain desirable cell types. These cells types produce factors (e.g., interferons) that stimulate other cells to grow and are used to treat certain types of cancer.

ITA's Materials Dispersion Apparatus (MDA) Minilab

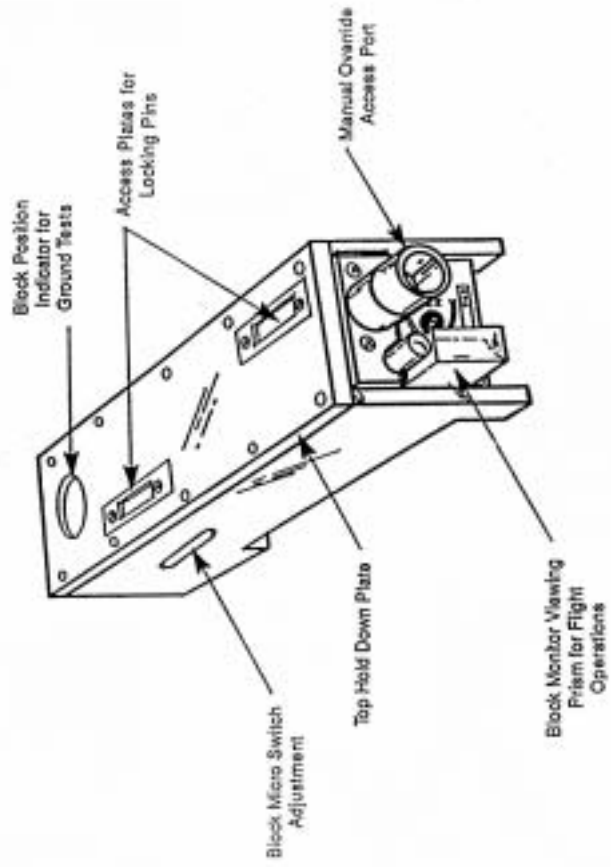

MDA Minilab Hardware Configuration for the CMIX-2 Mission on STS-56

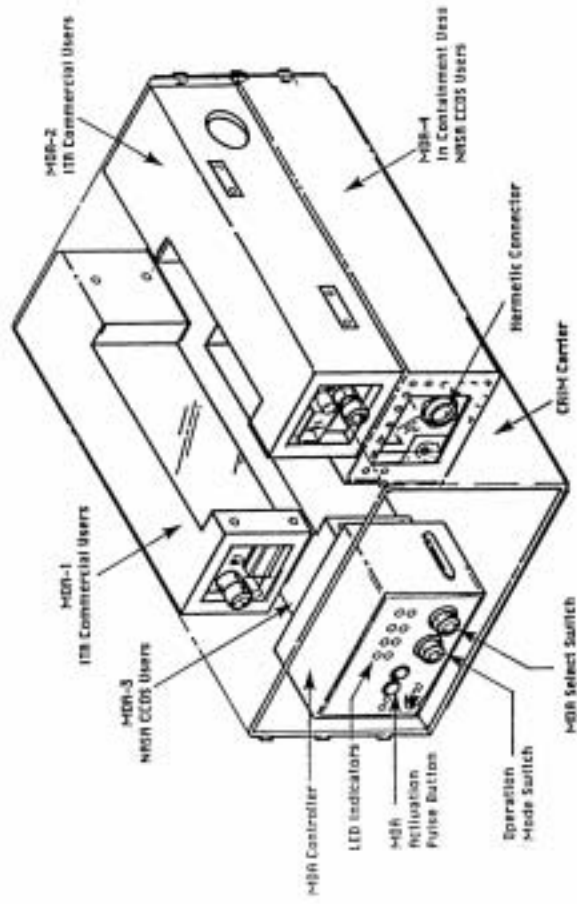

Bioprocessing Module Containment Levels

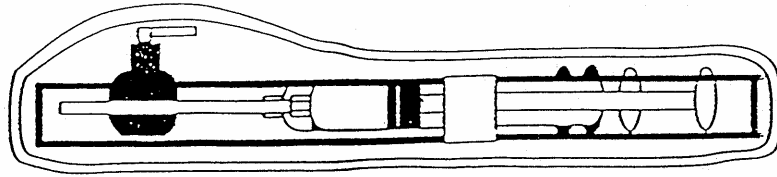

TWO HEAT-SEALED FEP TEFLON BAGS

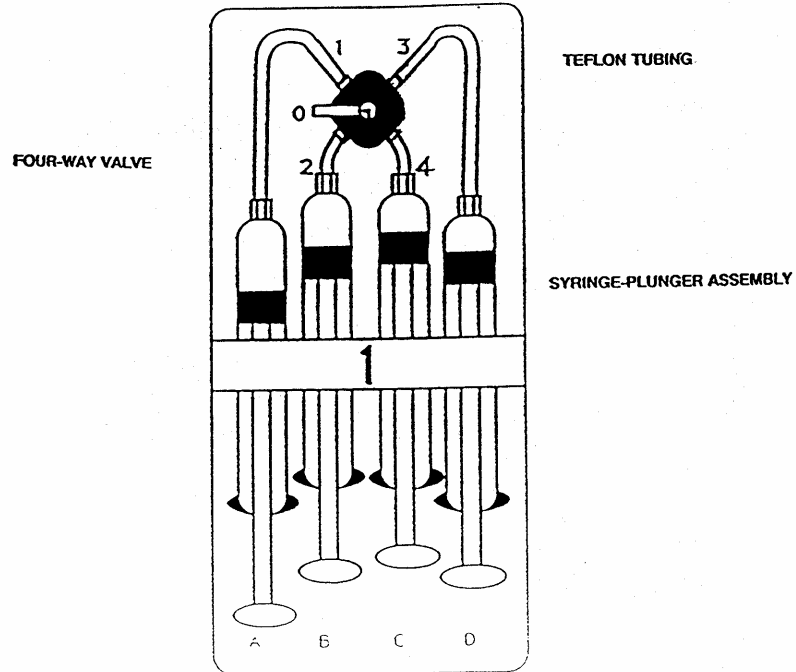

Bioprocessing Module Stowage Pouch (Open)

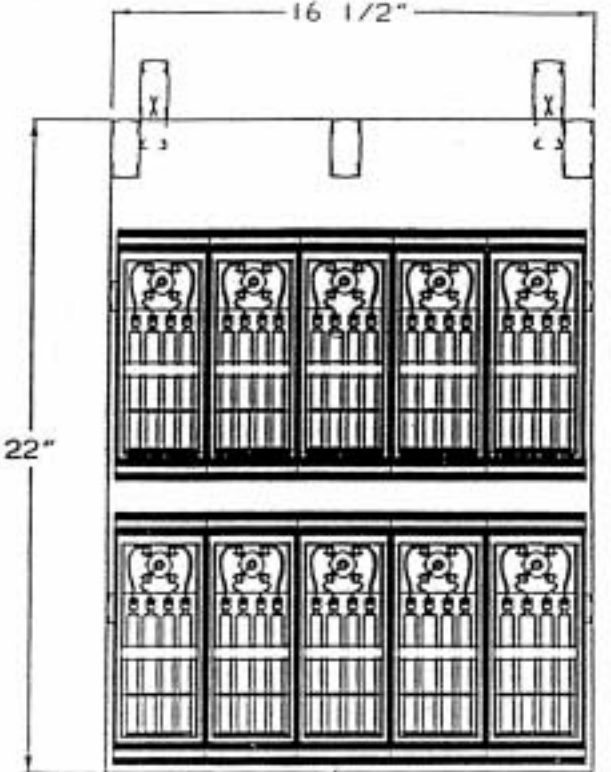

Bioprocessing Module Stowage Pouch (Open)

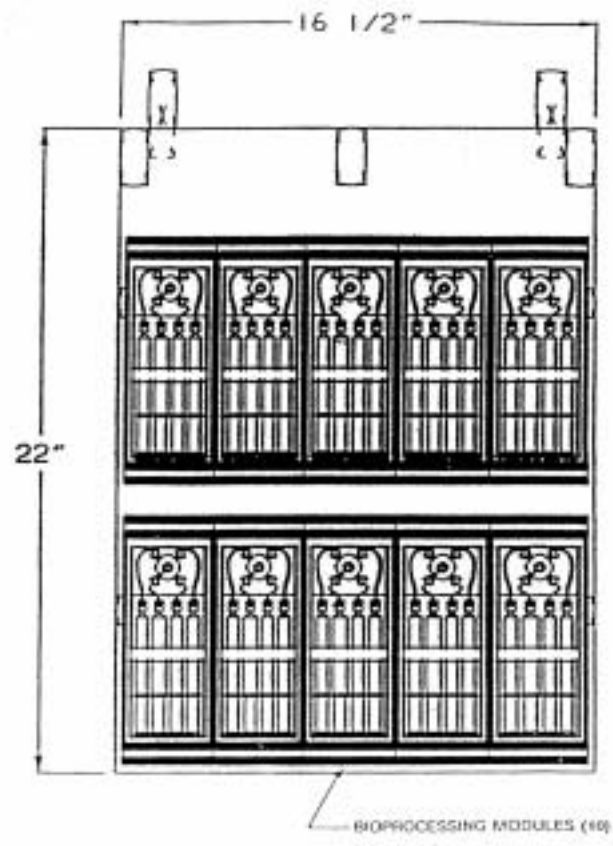

Experiments developed by ITA and its affiliates include:

- Collagen Reconstitution (MDA): This experiment will study collagen fibril growth in microgravity to develop unique and complex products that mimic natural tissue structures. Potential applications include corneal and intraocular implants, bone repair materials and tendon/ligament grafts.
- Microencapsulation (MDA): Drug microencapsulation techniques will be studied to improve chemotherapy drug delivery, to encapsulate inhalant medications and to enhance radiographic (X-Ray) procedures.
- Urokinase Protein Crystal Growth (MDA): Urokinase will be used to grow crystals to help determine the enzyme's three-dimensional (3-D) structure for use in developing a blocking or therapeutic drug that prevents the spread of breast cancer.
- Bacterial Aldolase and Rabbit Muscle Aldolase Protein Crystal Growth (MDA): Two types of aldolase will be used to grow crystals to determine the enzymes' 3-D structures for use in research on genetic illnesses.
- HIV Reverse Transcriptase (MDA): Reverse Transcriptase will be used to grow crystals to determine the enzyme's 3-D structure for use in AIDS research.
- RNA Protein Crystal Growth (MDA): Ribonucleic acid (RNA) will be used to grow crystals to determine the enzyme's 3-D structure for use in cell pharmacology and in designing continuous catalytic reactors.
- Methylase Protein Crystal Growth (MDA): This experiment will grow crystals to study the interaction between methylase and deoxyribonucleic acid (DNA) for use in identifying potential biomedical/biotechnology applications.
- Lysozyme Protein Crystal Growth (MDA): Lysozyme will be used to grow crystals to confirm the quality of flight conditions and to extend on-going studies of lysozyme crystallization for biomedical applications.
- DNA-Heme Protein Crystal Growth (MDA): This experiment will grow crystals to study their 3-D structure for use in identifying potential biomedical/biotechnology applications.
- Brine Shrimp Development (MDA): Brine shrimp development will involve hatching tiny Artemia Salina shrimp eggs in space to determine how microgravity affects early development. The shrimp are being studied as a potential space food source.
- Cell Research (MDA): This experiment will explore fluids and cell mixing for cell culturing on Space Station Freedom.

Other commercial MDA experiments include inorganic assembly (proprietary), myoglobin protein crystal growth, dye and yeast cell diffusion, and engineering tests. Potential commercial applications are expected in areas such as environmental sciences, drug research and development and cell pharmacology. Engineering tests will be performed to obtain data on liquid-to-liquid diffusion and magnetic mixing rates to verify normal MDA operations and provide "baseline" diffusion data.

- Mustard Seed Germination (MDA-student): Seeds and newly developing reproductive tissue of Brassica Rapa will be flown. The seeds will be dry and the tissue will be immersed in an inert culture medium. The materials returned will be used to propagate successive generations of the plant to assess any long-term effects on heredity patterns. This is a follow-on to an STS-52 experiment.

- Fish Egg Hatching (MDA-student): Using fish eggs, this experiment will study how microgravity affects the hatching process of the annual killifish of Zanzibar, Africa.
- Heart Cells In Culture (MDA-student): Using heart cells, this experiment will attempt to determine the effect(s) of microgravity upon the morphology and rate of heart "beats" of heart muscle cells.
- Mushroom Spore Generation (MDA-student): Using a selected strain of *Agaricus bisporus* (the cultivated mushroom), this experiment will attempt to determine the effect(s) of microgravity on the development of mushroom spores. The spores then will be used as a comparison and later, lead to the eventual growth of new and improved mushrooms.
- Mustard-Spinach Seed Germination (MDA-student): This experiment will attempt to determine the effects of microgravity on the mustard- spinach seed germination process. The germinated seeds will be compared with Earth-grown sprouts.

On-orbit Operations

The MDA minilabs each consist of an upper and lower block that contain a matching number of "wells" (holes) filled with different substances. The blocks are aligned at launch so that the holes do not "line up" and the materials in the wells do not touch each other. When the proper microgravity level is reached, the upper blocks will be moved in relation to the lower blocks so the materials in matching wells come into contact to allow dispersion (or mixing) of the different substance.

To complete microgravity operations, the blocks again will be moved to bring a third set of reservoirs to mix additional fluids or to fix the process for selected reservoirs. A prism window in each MDA allows the crew member to determine the alignment of the blocks.

To activate the MDAs, the crew will open the CRIM door to access the MDAs and the MDA Controller and Power Supply. Activation will occur simultaneously and is required as early as possible in the mission, followed by minimum microgravity disturbances for a period of at least 8 hours. The crew will operate switches to activate each MDA, and once all the MDAs are activated, the CRIM door will be closed.

Deactivation of each MDA will occur automatically at different intervals. For example, one MDA will automatically deactivate within minutes of being activated, whereas one will not deactivate at all. Deactivation of the other two MDAs will occur later in the mission. Once the Shuttle lands, the MDA minilabs will be deintegrated and the samples will be returned to the researchers for post-flight analyses.

The crew also will activate the BPMs, which consist of four plastic syringes. The syringes are interconnected by tubing to a four-way valve attached to an aluminum tray. The first syringe of each BPM will contain live cells. The second syringe will contain a mediator of cell growth or function (e.g., an activator), and the remaining two syringes will contain a chemical fixative.

To activate the BPMs, the crew will open the BPM valve to mix the cells with growth mediator. After specified times, the crew will terminate each BPM test by turning the valve to mix cells with fixative to preserve cellular structures in space before returning to Earth. Post-flight analyses will evaluate cell growth and production of materials, including interferons.

Principal Investigator for the CMIX-2 payload is Dr. Marian Lewis of the UAH CMDS. John Cassanto, President, ITA, is Program Manager for the commercial MDAs.

SPACE TISSUE LOSS-3 (STL-3)

Bone and Muscle Cell Culture Experiments

NASA Principal Investigator:
Emily R. Morey-Holton, Ph.D.
Ames Research Center, Mountain View, Calif.

U. S. Army Principal Investigator:
George Kearney, Ph.D.
Walter Reed Army Institute of Research, Washington, DC

The musculoskeletal system is subjected to constant load by the gravitational acceleration of the Earth. The structure and function of bone and muscle tissue has been shaped throughout evolution by this constant stress. The impact of diminution of this acceleration is not understood but may have profound influence on the function of these gravity- related systems.

Muscle tissue in space-flown animals and humans has been shown to respond to exposure to the orbital environment by loss of contractile protein, alteration in the energy provision mechanisms within the cells and changes in the structure of nerve/muscle interfaces. When growing bones are unloaded in space, bone growth is slowed; bones show delayed maturation which translates to an increase in mass and mineral content without the anticipated increase in bone strength.

The changes in the musculoskeletal system are most pronounced in, but not limited to the weight-bearing limbs. These changes hinder one's capability to function when returning to Earth. The bone changes coupled with the decrease in the mass of the gravity-dependent muscles make movement difficult, and the individual may be prone to accidents because of this instability.

The working hypothesis of the STL project is that the influence of gravity is active at the level of individual cells and that totally defined cellular models of the changes noted in whole animal preparations can be developed to study the process at the molecular level. The ultimate aim of the project is to delineate the biochemical pathways and mechanisms responsible for the noted changes and test the feasibility of pharmaceutical intervention to slow, arrest or reverse the progress of the tissue loss.

The current mission will be used to reproduce and verify the changes in cell function observed in the two previous deployments on the Shuttle. Changes in protein levels, enzyme activities and gene functions will be monitored. Alteration in the morphology and nature maturation of the cells will be determined upon return and followed for an extended period of recovery. These results will be compared to changes noted in space- flown whole animal function to establish the validity and applicability of the cellular model.

The significance of the current muscle cell experiments is threefold. First, previous results have indicated that the process of development and differentiation in cultured muscle satellite cells is impaired by an apparent disruption of the ability of the precursor cells to fuse to form muscle fibers. These cells function in the normal repair process for muscle so impact on the ability of the cells to fuse is considered clinically significant. Recovery of muscle mass and strength following spaceflight might be hastened if these cells are fully functional during the repair process in the muscle following return to normal gravity.

The second area of significance is the apparent stability of the changes noted. Space flown cells were unable to fuse for some 40 cell cycles following return (35 days). Ground control cells were 100 percent fused within 12 days. Most reported alterations in cell function only have been shown to persist for hours to days following return to normal gravity conditions. Changes in the function of the muscle cells are the most stable reported thus far. If initial observations are verified in the current experiment, these cells would allow extensive ground-based study of the affects of space flight without the need for constantly replenished supplies of experimental material that are changing while the experiments are in process.

A third area for potential application of data from this project is satellite cell therapy. Disorders impacting muscle tissues such as the muscular dystrophies are logical targets for gene replacement therapy. The gene involved in Duchenne muscular dystrophy is the largest known and delivery with viral carriers is probably not feasible. Genetically altered satellite cells currently are being studied for use as carriers for replacement genes. This uses the natural reparative system of the muscle to effect restoration of function. The impairment of natural fusion potentially allows production of therapeutically significant numbers of satellite cells from clones known to express the desired genetic properties but without foreign surface antigens which would necessitate immunosuppression of the transplant recipients.

The significance of the bone cells experiment also is threefold. Previous results from STL have indicated that the metabolism of bone forming cells may change during space flight and that mineralization of the bone fibers (matrix) may be impaired. Such changes at the whole bone level would cause decreased bone strength. The results will be repeated and expanded. For example, the type and amount of bone-specific products that the cells contain at the end of this 8-day flight will be studied. In addition, cells will be cultured upon return to Earth to determine if the spaceflight induced changes can be reversed after return to Earth.

Finally, the amount and type of product found in the cell culture will be compared to similar data being obtained in the whole rat (experiment PARE.03 below) to determine if spaceflight changes in bone cell cultures are similar to those found in the animal. Decrease in the activity of the bone forming cells can alter the amount and type of bone formed and contribute to the changes in bone strength. Focusing on the initial event in the bone adaptation process by analyzing cell changes during flight will help us determine if the changes at the cellular level trigger the changes in bone strength. Understanding what gives bone its strength would be of great value in treating individuals at risk for bone fracture or for better understanding why some people have weak bones.

PHYSIOLOGICAL AND ANATOMICAL RODENT EXPERIMENT.03

The third Physiological and Anatomical Rodent Experiment (PARE.03) on STS-56 is a secondary payload that will fly in a locker in the Space Shuttle's mid-deck.

PARE.03 consists of two experiments (PARE.03A and PARE.03B) with different goals and different principal investigators. Both will share the same group of rats. The goals of each experiment are fully compatible with the procedures and goals of the other. Both experiments endeavor to get new data that will provide a cohesive view of bone biology during and following spaceflight.

Acute Adaptation of Bone to Spaceflight (PARE.03A)

Principal Investigator:

Emily R. Morey-Holton, Ph.D.

Life Science Division

NASA-Ames Research Center

Mountain View, Calif.

Co-Investigator: Russell T. Turner, Ph.D.

Department of Orthopaedics

Mayo Clinic

Rochester, Minn.

The load imposed by Earth's environment throughout evolution has determined the size, shape and strength of the skeletal system. When growing bones are unloaded on Earth or in space, bone growth is slowed. (In unloading, the rat is placed in tail traction so its hind legs no longer bear weight. The rat can move freely using its front paws. This technique simulates many, but not all, of the effects of microgravity on rat bones.) Bones show delayed maturation, which translates to an increase in mass and mineral content without the expected increase in bone strength.

The major hypothesis of this project is that gravity is necessary for normal development of bone structure. Another part of the hypothesis is that decreased gravity or skeletal unloading causes defective skeletal growth. This defective growth is characterized by delayed maturation and increased bone mass without increased bone strength.

The proposed flight experiment is designed to confirm the bone defects measured in past flight experiments. These measurements include bone mass, mineralization rates and strength at multiple sampling sites. The experiment also will focus on sites and molecular mechanisms of the growth defect. In addition, scientists will observe recovery from spaceflight to determine if the defects are corrected by return to Earth after either 36 or 72 hours. During the Space Shuttle mission, scientists on the ground will perform the same experiment, using a ground-based rat model that simulates certain aspects of spaceflight. This will help determine the validity of this system for predicting spaceflight responses in bone.

PARE.03A is important for two reasons. When individuals are exposed to the microgravity of space or unloading on Earth, there appears to be a change in bone structure. In unloading, the rat is placed in tail traction so its hind legs no longer bear weight, but the rat can move freely using its front paws. This technique simulates many of the effects of microgravity on rat bones.

Perhaps muscle no longer exerts enough force or bone, by itself, is not stimulated to combine bone cell activity, cell products and mineral into a bone structure that is as strong as a bone produced on Earth.

Regardless of the cause, the changes in bone structure hinder one's capability to function when returning to Earth. Movement patterns are difficult, and the individual may be prone to bone fractures because of this instability. We need to find out what parts of the bone structure are changed. We also need to determine the

extent to which they change, the impact of the changes on bone strength and how to prevent the changes from occurring.

Second, unloading of the bones on Earth causes changes in the production of various bone cell products. Suggestions of similar changes have been reported in rapidly growing rats during short-duration spaceflights. The altered products cause an imbalance of the normal ordered array of bone structure, resulting in a weaker bone. However, the imbalance may be different during spaceflight than during unloading on Earth. If the imbalance is different, then the mechanisms responsible for the weaker bone may be different in space than on Earth. This would require different treatments to prevent the changes. Thus, one part of this flight experiment is an Earth-based experiment on rats of the same age unloaded on Earth.

The PARE.03A project will examine the extent to which the bone-forming cells change their activity after exposure to microgravity for 8 days. It also will investigate whether these changes are reversed within 3 days of return to Earth.

Cell Kinetic and Histomorphometric Analysis of Microgravitational Osteopenia (PARE.03B)

Principal Investigator:

W. Eugene Roberts, D. D. S., Ph.D.

Co-Investigator:

Lawrence Garetto, Ph.D.

Departments of Orthodontics and Physiology/Biophysics

Indiana University Schools of Dentistry and Medicine, Indianapolis, Ind.

The influence of gravity on the development and function of bone-forming cells (osteoblasts) is a basic biological question that may be common to many gravity-sensing organisms. Because the production of bone-forming cells is mechanically sensitive, the force exerted by gravity is an important experimental variable for understanding mechanisms underlying osteoblast production.

Gravity is a ubiquitous force that is inescapable on Earth. As such, all Earth-bound organisms have evolved under the presence of this force. Data from both human and animal experiments suggest that exposure to the microgravity environment of space may alter the normal "turnover" or renewal processes of the skeletal bones. Under normal conditions in Earth's gravity field, the turnover process is the result of a balance between bone removal and bone formation. However, during spaceflight, bone formation is inhibited. As a result, the turnover of bone is unbalanced, resulting in a net loss.

Previous experiments on both American and Russian missions have shown that a lack of gravity appears to interfere with production of osteoblasts in animals subjected to spaceflight. This, in turn, ultimately may result in reduced or altered capability to form bone mass in these animals. Mechanical force is known to influence the formation of preosteoblast cells. The main hypothesis of this experiment is that osteoblast production is blocked during spaceflight but rapidly recovers within hours to days after return to Earth's 1-g environment.

As mentioned previously, the process of normal osteoblast production may have evolved with gravity as an essential co-factor. This important question is most effectively addressed by studying the effects of the removal of gravity on different types of bone tissue.

The PARE.03B experiment will examine how the lack of gravity encountered during spaceflight affects the production of osteoblasts. One goal is to use a specific marker for DNA synthesis to examine preosteoblast cell proliferation. This has not been done previously following spaceflight and will provide new and unique data on the mechanism of osteoblast production.

A second goal is to confirm previous data suggesting that preosteoblast production is inhibited immediately following spaceflight. The third goal of this study is to determine if the block in osteoblast formation

occurs throughout the skeleton or if it is localized in specific types of bones. This will be measured by examining the process in different bones. These include the bones of the upper and lower jaw, which are non-weight-bearing but mechanically loaded in function; the shin bone (tibia), which is weight-bearing and the bones of the lower back.

These vertebral bones differ from other bones in the rat in that they are continuously undergoing a balanced turnover or renewal process. In other words, they undergo both removal by osteoclasts and new bone formation at other sites by osteoblasts.

Finally, a fourth goal is to determine how soon osteoblast production recovers after return to Earth. Measurements made immediately following return to Earth will be compared in animals allowed to recover for 36 and 72 hours.

The PARE.03B experiment will provide basic insights into the cellular mechanisms of the mechanical control of osteoblast production and function in bone. This kind of detailed knowledge at the cellular level may provide biological insights into mechanisms underlying bone diseases in humans on Earth. Bone diseases such as osteoporosis affect a large segment of society. They result in billions of dollars in yearly health care and related costs due to lost productivity. Successful treatment of diseases such as these requires a sufficient understanding of the basic biology of osteoblast production to adequately and accurately develop treatment regimens.

PARE.03B will provide additional short-term flight data to that already collected on previous missions. It will provide new information on preosteoblast cell proliferation following spaceflight. In addition, it will extend our understanding of the recovery process of osteoblast production following return to a 1g environment. These experiments will yield answers to basic biological questions about the ability of Earth-evolved animals to adapt outside of their original evolutionary environment. This will better enable us to understand the role that mechanical force plays on Earth in maintaining our skeleton.

During spaceflight, changes have been noted in both the forelimbs and hindlimbs of growing male rats. Studies on the humerus and tibia have shown a decrease in the amount of bone formed during flight. In the cross sectional area of bone depicted under "Bone Structure", a bone marker was given to the animals prior to flight. The marker forms the line inside the bone section. The amount of bone formed during flight is the area between the marker and the outer bone surface.

During the same period of time, the ground animals form about 45 percent more bone at the surface of the bone shaft. If a similar area from each section (boxes) is enlarged, further differences between the flight and ground control rats can be seen.

In the flight bone, surface blood vessels appear to be blocked with debris and lipid deposits, the mineral may aggregate in smaller crystals and the collagen may be somewhat disorganized in a convoluted pattern. These changes may be responsible for the changes in bone strength. Data from the humerus, femur and tibia suggest that the flight bone is about the same size as the ground control bone, yet the amount of force required to break the bone is significantly less in the flight animals (see "Bone Strength"). In fact, the strength of the bone does not appear to increase as the bone increases in size, suggesting that bone deposited during flight does not contribute to bone strength.

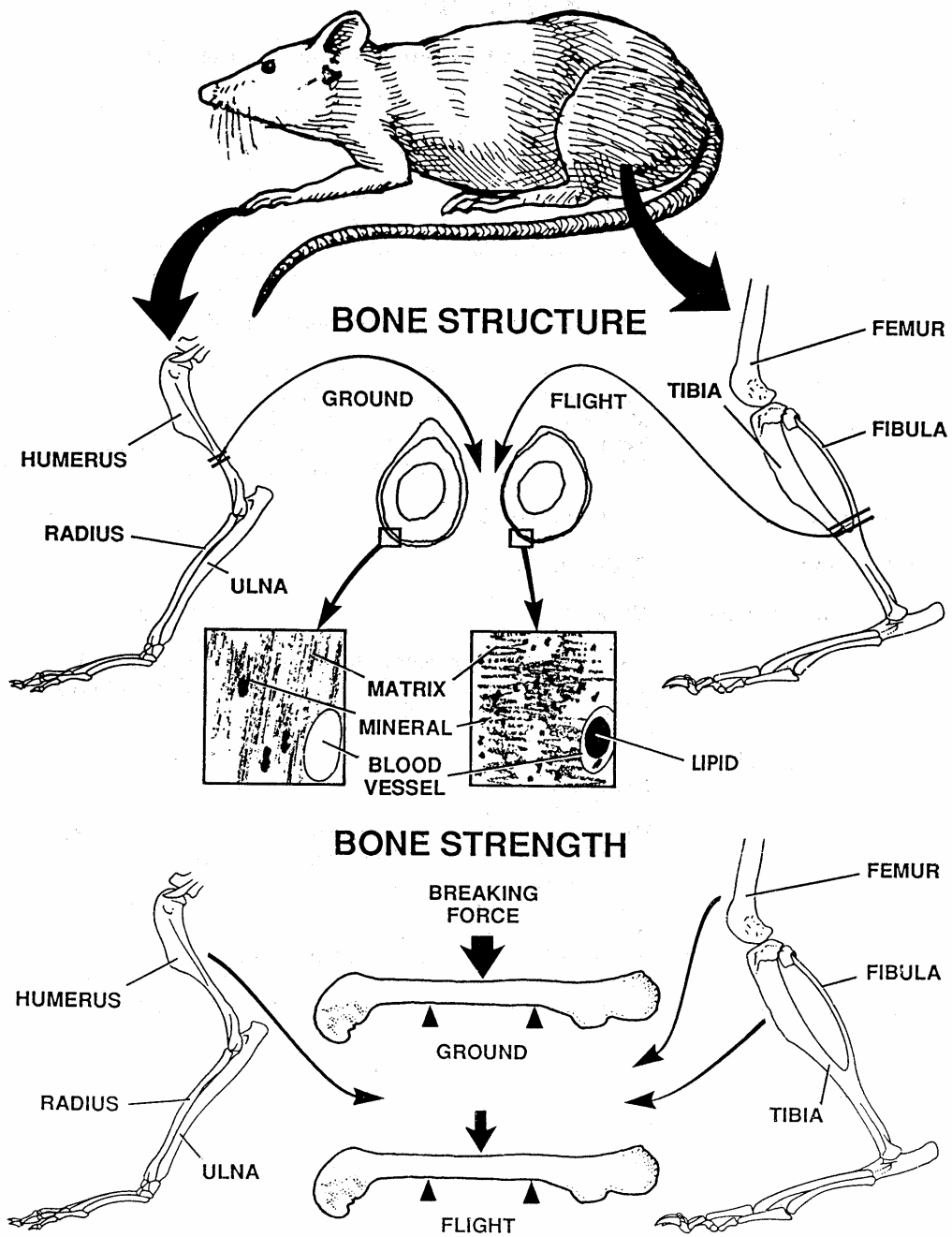

STS-56 CREWMEMBERS



STS056-S-002 -- STS-56 Discovery, Orbiter Vehicle (OV) 103, crewmembers, wearing launch and entry suits (LESs), pose for their official portrait. These five astronauts are assigned to the STS-56 Atmospheric Laboratory for Applications and Science 2 (ATLAS-2) mission. Left to right are mission specialist Kenneth D. Cockrell, plot Stephen S. Oswald, mission specialist Michael Foale, mission commander Kenneth Cameron, and mission specialist Ellen Ochoa.

No copyright is asserted for this photograph. If a recognizable person appears in the photo, use for commercial purposes may infringe a right of privacy or publicity. It may not be used to state or imply the endorsement by NASA or by any NASA employee of a commercial product, process or service, or used in any other manner that might mislead. Accordingly, it is requested that if this photograph is used in advertising and other commercial promotion, layout and copy be submitted to NASA prior to release.

PHOTO CREDIT: NASA or National Aeronautics and Space Administration.

BIOGRAPHICAL DATA

KENNETH D. CAMERON, 43, Col., USMC, is Commander of the second Atmospheric Laboratory for Applications and Science (ATLAS) mission. Selected to be an astronaut in 1984, Cameron, from Cleveland, Ohio, is making his second Shuttle flight.

Cameron served as Pilot on Atlantis' STS-37 mission in April 1991 which featured the deployment of the Gamma Ray Observatory.

A graduate of Rocky River High School in Rocky River, Ohio, in 1967, Cameron received bachelor and master of science degrees in aeronautics and astronautics from the Massachusetts Institute of Technology in 1978 and 1979, respectively.

Cameron enlisted in the Marine Corps in 1969 and earned a commission in 1970 at Officer's Candidate School in Quantico, Va. He received his naval aviator wings in 1973 and has logged over 3,400 hours flying time in 46 different types of aircraft.

STEPHEN S. OSWALD, 41, is the Pilot of STS-56. Selected as an astronaut in 1985, he was born in Seattle, Wash., but considers Bellingham, Wash., his hometown. He made his first flight as the Pilot aboard Discovery on STS-42 in January 1992, an international microgravity laboratory mission.

Oswald graduated from Bellingham High School, Bellingham, Wash., in 1969 and received a bachelor's degree in aerospace engineering from the Naval Academy in 1973. He was designated a naval aviator in September 1974 and flew the Corsair II aboard the USS Midway in the Western Pacific and Indian Oceans from 1975 through 1977. In 1978, Oswald attended the Naval Test Pilot School.

After leaving the Navy, he joined Westinghouse Electric Corp. as a test pilot in developmental flight testing of various airborne weapons systems, including the F-16C and B-1B radars. Oswald remains active in the U.S. Naval Reserve, currently assigned as Commanding Officer of the Naval Space Command Reserve Unit, Dahlgren, Va. Oswald has logged more than 5,400 hours in 40 different aircraft and has logged over 193 hours in space.

MICHAEL FOALE, Ph.D., 36, will serve as Mission Specialist 1 (MS1), making his second space flight. Selected as an astronaut in 1987, Foale considers Cambridge, England, his hometown.

Foale graduated from Kings School, Canterbury, England, in 1975. He attended the University of Cambridge, Queens' College, receiving a bachelor of arts degree in physics in 1978. He completed a doctorate in laboratory astrophysics at Cambridge University in 1982.

Prior to his selection as an astronaut in 1987, Foale worked for NASA as a payloads officer in Mission Control at the Johnson Space Center, Houston. He made his first space flight on STS-45, the first Atmospheric Laboratory for Applications and Science flight.

BIOGRAPHICAL DATA

KENNETH D. COCKRELL, 42, will serve as Mission Specialist 2 (MS2) and will be making his first space flight. Selected as an astronaut in 1990, Cockrell considers Austin, Texas, his hometown.

Cockrell graduated from Rockdale High School, Rockdale, Texas, in 1968, received a bachelor of science degree in mechanical engineering from the University of Texas in 1972 and a master of science degree in aeronautical systems from the University of West Florida in 1974.

Cockrell received a commission through the Naval Aviation Reserve Officer Candidate program at the Naval Air Station in Pensacola, Fla., in 1972 and was designated a naval aviator in 1974. He has flown various types of aircraft and has logged over 4,900 flying hours, including 650 aircraft carrier landings.

ELLEN OCHOA, Ph.D., 34, will serve as Mission Specialist 3 (MS3) on STS- 56. She was born in Los Angeles, Calif., but considers La Mesa, Calif., her hometown. Selected as an astronaut in 1990, Ochoa will be making her first space flight.

Ochoa graduated from Grossmont High School in La Mesa in 1975. She received a bachelor of science degree in physics from San Diego State University in 1980 and received a master of science degree and a doctorate in electrical engineering from Stanford University in 1981 and 1985, respectively.

Upon graduation from Stanford, Ochoa served on a research staff position at Sandia National Laboratories, Livermore, Calif., specializing in work with optical processing. In 1988, she joined NASA's Ames Research Center, Moffett Field, Calif., to work with optical recognition systems for space automation. At the time of her selection as an astronaut, Ochoa was serving as Chief of the Intelligent Systems Technology Branch at Ames.

MISSION MANAGEMENT FOR STS-56

NATIONAL AERONAUTICS & SPACE ADMINISTRATION

NASA Headquarters, Washington, DC

Office of Space Flight

Jeremiah W. Pearson III	Associate Administrator
Bryan O'Connor	Deputy Associate Administrator
Tom Utsman	Space Shuttle Program Director
Leonard Nicholson	Space Shuttle Program Manager (JSC)
Col. Brewster Shaw	Deputy Space Shuttle Program Manager (KSC)

Office of Space Science and Applications

Dr. Lennard A. Fisk	Associate Administrator
Mr. Alphonso V. Diaz	Deputy Associate Administrator
Mr. Robert Benson	Director, Flight Systems Division
Dr. Shelby G. Tilford	Director, Earth Science and Applications Division
Dr. George Withbroe	Director, Space Physics Division
Mr. Paul DeMinco	Spartan-201 Program Manager
Mr. George Esenwein	ATLAS 2 Payload Manager
Dr. Jack Kaye	ATLAS 2 Program Scientist
Mr. Earl Montoya	ATLAS 2 Program Manager
Dr. William Wagner	Spartan-201 Program Scientist

Office of Safety and Mission Quality

Col. Frederick Gregory	Associate Administrator
Charles Mertz	(Acting) Deputy Associate Administrator
Richard Perry	Director, Programs Assurance

Kennedy Space Center, FL

Robert L. Crippen	Director
James A. "Gene" Thomas	Deputy Director
Jay F. Honeycutt	Director, Shuttle Management and Operations
Robert B. Sieck	Launch Director
Dave King	Discovery Flow Director
J. Robert Lang	Director, Vehicle Engineering
Al J. Parrish	Director of Safety Reliability and Quality Assurance
John T. Conway	Director, Payload Management and Operations
P. Thomas Breakfield	Director, Shuttle Payload Operations

Marshall Space Flight Center, Huntsville, AL

Thomas J. Lee	Director
Dr. J. Wayne Littles	Deputy Director
Harry G. Craft Jr.	Manager, Payload Projects Office
Teresa Vanhooser	Mission Manager, Atmospheric Laboratory for Applications and Science 2
Dr. Timothy Miller	Mission Scientist, Atmospheric Laboratory for Applications and Science 2
Alexander A. McCool	Manager, Shuttle Projects Office
Dr. George McDonough	Director, Science and Engineering
James H. Ehl	Director, Safety and Mission Assurance
Otto Goetz	Manager, Space Shuttle Main Engine Project
Victor Keith Henson	Manager, Redesigned Solid Rocket Motor Project
Cary H. Rutland	Manager, Solid Rocket Booster Project
Parker Counts	Manager, External Tank Project

Johnson Space Center, Houston, TX

Aaron Cohen	Director
Paul J. Weitz	Deputy Director
Daniel Germany	Manager, Orbiter and GFE Projects
David Leestma	Director, Flight Crew Operations
Eugene F. Kranz	Director, Mission Operations
Henry O. Pohl	Director, Engineering
Charles S. Harlan	Director, Safety, Reliability and Quality Assurance

Stennis Space Center, Bay St. Louis, MS

Roy S. Estess	Director
Gerald Smith	Deputy Director
J. Harry Guin	Director, Propulsion Test Operations

Ames-Dryden Flight Research Facility, Edwards, CA

Kenneth J. Szalai	Director
Robert R. Meyers Jr.	Assistant Director
James R. Phelps	Chief, Shuttle Support Office.

Goddard Space Flight Center, Greenbelt, MD

Dr. John Klineberg	Center Director
Thomas E. Huber	Director, Engineering Directorate
Robert Weaver	Chief, Special Payloads Division
David Shrewsbury	Associate Chief, Special Payloads Division
Jack Pownell	Spartan Mission Manager
Frank Collins	Spartan Project Manager
Richard Fisher	Spartan Principal Investigator

DEPARTMENT OF DEFENSE SECONDARY PAYLOAD MANAGEMENT

Key Management Participants

Mission Director: Lieutenant General Edward P. Barry Jr., USAF,
Commander, HQ Space and Missile Systems Center, Los Angeles AFB

Deputy Mission Director: Colonel Robert H. Ballard, Program Manager, Space Test and Small Launch
Vehicles Program, Hq, Space and Missile Systems Center, Los Angeles AFB





Assistant Deputy Mission Director: Lt. Colonel James McLeroy, Executive Director, Operating Location
AW (HQ Space and Missile Systems Center), at Johnson Space Center, Houston

USAF Secondary Payload Managers (JSC/OL-AW):

Capt. David Goldstein
Capt. Richard Martinez
Capt. Reid Maier
Capt. John Hennessey

SHUTTLE FLIGHTS AS OF APRIL 1993

53 TOTAL FLIGHTS OF THE SHUTTLE SYSTEM -- 28 SINCE RETURN TO FLIGHT

					
STS-52 10/22/92 - 11/01/92			STS-53 12/02/92 - 12/09/92		
STS-50 06/25/92 - 07/09/92			STS-42 01/22/92 - 01/30/92		
STS-40 06/05/91 - 06/14/91			STS-48 09/12/91 - 09/18/91		
STS-35 12/02/90 - 12/10/90	STS-51L 01/28/86		STS-39 04/28/91 - 05/06/91	STS-46 07/31/92 - 08/08/92	
STS-32 01/09/90 - 01/20/90	STS-61A 10/30/85 - 11/06/85		STS-41 10/06/90 - 10/10/90	STS-45 03/24/92 - 04/02/92	
STS-28 08/08/89 - 08/13/89	STS-51F 07/29/85 - 08/06/85		STS-31 04/24/90 - 04/29/90	STS-44 11/24/91 - 12/01/91	
STS-61C 01/12/86 - 01/18/86	STS-51B 04/29/85 - 05/06/85		STS-33 11/22/89 - 11/27/89	STS-43 08/02/91 - 08/11/91	
STS-9 11/28/83 - 12/08/83	STS-41G 10/05/84 - 10/13/84		STS-29 03/13/89 - 03/18/89	STS-37 04/05/91 - 04/11/91	
STS-5 11/11/82 - 11/16/82	STS-41C 04/06/84 - 04/13/84		STS-26 09/29/88 - 10/03/88	STS-38 11/15/90 - 11/20/90	
STS-4 06/27/82 - 07/04/82	STS-41B 02/03/84 - 02/11/84		STS-51-I 08/27/85 - 09/03/85	STS-36 02/28/90 - 03/04/90	
STS-3 03/22/82 - 03/30/82	STS-8 08/30/83 - 09/05/83		STS-51G 06/17/85 - 06/24/85	STS-34 10/18/89 - 10/23/89	
STS-2 11/12/81 - 11/14/81	STS-7 06/18/83 - 06/24/83		STS-51D 04/12/85 - 04/19/85	STS-30 05/04/89 - 05/08/89	
STS-1 04/12/81 - 04/14/81	STS-6 04/04/83 - 04/09/83		STS-51C 01/24/85 - 01/27/85	STS-27 12/02/88 - 12/06/88	STS-54 01/13/93 - 01/19/93
			STS-51A 11/08/84 - 11/16/84	STS-61B 11/26/85 - 12/03/85	STS-47 09/12/92 - 09/20/92
			STS-41D 08/30/84 - 09/05/84	STS-51J 10/03/85 - 10/07/85	STS-49 05/07/92 - 05/16/92
OV-102 Columbia (13 flights)	OV-099 Challenger (10 flights)	OV-103 Discovery (15 flights)	OV-104 Atlantis (12 flights)	OV-105 Endeavour (3 flights)	