

FAST User's Guide

Updated August 2005

J.M. Jonkman
M.L. Buhl Jr.

Technical Report
NREL/TP-500-38230
October 2005

This guide is frequently updated and revised.
For the latest online version see
<http://wind.nrel.gov/designcodes/simulators/fast/FAST.pdf>

NREL is operated by Midwest Research Institute • Battelle Contract No. DE-AC36-99-GO10337



FAST User's Guide

Updated August 2005

J.M. Jonkman
M.L. Buhl Jr.

Prepared under Task Nos. WER1.1220, WER2.1220, WER3.1910,
WER4.3102, and WER5.3115

Technical Report
NREL/TP-500-38230
October 2005

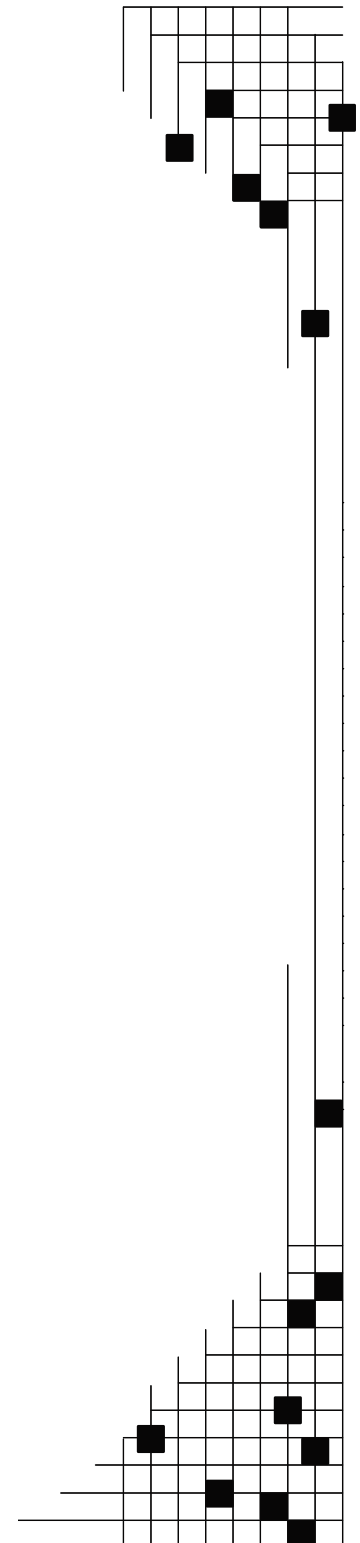

National Renewable Energy Laboratory
1617 Cole Boulevard, Golden, Colorado 80401-3393
303-275-3000 • www.nrel.gov

Operated for the U.S. Department of Energy
Office of Energy Efficiency and Renewable Energy
by Midwest Research Institute • Battelle

Contract No. DE-AC36-99-GO10337

NOTICE

This report was prepared as an account of work sponsored by an agency of the United States government. Neither the United States government nor any agency thereof, nor any of their employees, makes any warranty, express or implied, or assumes any legal liability or responsibility for the accuracy, completeness, or usefulness of any information, apparatus, product, or process disclosed, or represents that its use would not infringe privately owned rights. Reference herein to any specific commercial product, process, or service by trade name, trademark, manufacturer, or otherwise does not necessarily constitute or imply its endorsement, recommendation, or favoring by the United States government or any agency thereof. The views and opinions of authors expressed herein do not necessarily state or reflect those of the United States government or any agency thereof.

Available electronically at <http://www.osti.gov/bridge>

Available for a processing fee to U.S. Department of Energy and its contractors, in paper, from:

U.S. Department of Energy
Office of Scientific and Technical Information
P.O. Box 62
Oak Ridge, TN 37831-0062
phone: 865.576.8401
fax: 865.576.5728
email: <mailto:reports@adonis.osti.gov>

Available for sale to the public, in paper, from:

U.S. Department of Commerce
National Technical Information Service
5285 Port Royal Road
Springfield, VA 22161
phone: 800.553.6847
fax: 703.605.6900
email: orders@ntis.fedworld.gov
online ordering: <http://www.ntis.gov/ordering.htm>



DOCUMENT REVISION RECORD

Revision	Date	Description
1.00	09-Jul-2002	First publication. Supports FAST v4.0.
1.10	04-Sep-2002	Inserted an additional output channel (TipSpdRat or TSR) and additional prefixes (“-”, “_”, “m”, or “M”) for reversing the sign of the selected output channels. Still supports FAST v4.0.
1.20	28-Feb-2003	Clarified the descriptions of several input variables.
1.21	31-Mar-2003	Replaced drivetrain references from “rotational” to “torsional.”
1.22	03-Apr-2003	Fixed the labels on the drawings of the coordinate systems.
1.30	08-Sep-2003	Added description of the FAST-to-ADAMS preprocessor and associated inputs. Added placeholders for the inputs of the currently undocumented FAST linearization and noise prediction routines. Clarified the descriptions of several input variables. Renamed input switch TeetDMod to TeetMod and altered its functionality so that routine UserTeet() can implement user-defined teeter spring and damper models. Added supplementary output names for the blade root in-plane, out-of-plane, flap, and edge bending moments.
1.31	03-Oct-2003	Added description of the FAST linearization analysis capability. Clarified the descriptions of several input variables.
1.32	07-Oct-2003	Updated the example summary, AeroDyn, and linearization output files. Had the Linearization chapter type edited by NREL communications.
1.40	28-Oct-2003	Changed the extension of the input file names from .fad or .inp to “.fst” Added Alpha, PrecrvRef, and PreswpRef to the FAST-to-ADAMS preprocessor. Supports FAST v4.4.
1.41	07-Nov-2003	Inserted additional output channels for the blade and tower torsional deflections. Moved the origin of the nacelle/yaw coordinate system to the tower-top.
1.42	11-Dec-2003	Documented that the dummy supplied UserGen() routine now calls the sample UserVSCont() routine.
2.00	05-Mar-2004	Added description of new FAST furling capability and associated I/O. Added additional output channels for blade tip-to-tower clearances. Clarified the descriptions of several input variables. Supports FAST v5.0.
2.10	01-Oct-2004	Added a chapter on how to compile FAST. Documented upgrades relating to turbine control, including yaw and high-speed shaft brake control. Added a description on the interface between FAST and Simulink and on the interface between FAST and Bladed-style DLL master controllers. Clarified the descriptions of several input variables. Added supplementary output names for the angular speed and acceleration of the high-speed shaft and generator. Supports FAST v5.1.
3.00	09-Jun-2005	Added description of new platform motion and loading functionality. Documented upgrades relating to turbine control and output capabilities. Added additional output channels and names for the angular (rotational) deflections of the tower-top and blade tips. Clarified the descriptions of several input and output parameters. Supports FAST v6.0.
3.01	12-Aug-2005	Incorporated editorial changes from NREL communications. Added reference to the certification report from Germanischer Lloyd WindEnergie. Added a Sample Input Files section in the Input Files chapter. Added flowcharts for explaining how the program uses the blade pitch, nacelle yaw, variable-speed, generator, and HSS brake control input parameters during runtime. Modified the description of how Bladed-style DLL controllers are interfaced. Added supplementary output names for blade pitch angles and nacelle yaw motions and moment and modified the description of output CThrstRad. Still supports FAST v6.0.

TABLE OF CONTENTS

Document Revision Record	i
Table of Contents	iii
Figures	v
Tables	v
Foreword	vii
Acknowledgements	viii
Upgrading to FAST v6.0 from v5.1	ix
Upgrading to FAST v5.1 from v5.0	x
Upgrading to FAST v5.0 from v4.4	xii
Using This Manual	xiv
Modes of Operation	1
Running FAST	3
Compiling FAST	5
Model Description	7
General Description	7
Coordinate Systems.....	7
Inertial Frame Coordinate System	8
Tower-Base Coordinate System	8
Tower-Top/Base-Plate Coordinate System.....	8
Nacelle/Yaw Coordinate System.....	8
Shaft Coordinate System	9
Azimuth Coordinate System.....	9
Hub Coordinate System	9
Coned Coordinate Systems	9
Blade Coordinate Systems.....	9
Turbine Layout	10
Flexible Tower and Blades.....	10
Drivetrain.....	11
Generator	11
Nacelle Yaw	12
Rotor-Furl	12
Tail-Furl.....	13
Rotor-Teeter.....	14
Support Platform	15
Rotor Aerodynamics.....	16
Tail Fin Aerodynamics.....	16
Controls	25
General Description	25
Blade Pitch Control	25
Variable-Speed Torque Control	26

HSS Brake Control.....	27
Nacelle Yaw Control.....	28
Master Controllers and the Bladed-Style DLL Interface.....	30
Tip Brakes.....	32
Simulating Special Events.....	33
Turbine Startup	33
Normal Pitch-to-Feather Shutdown.....	33
Shutdown Where One Blade Fails to Feather.....	33
One Blade Feathers Accidentally.....	33
HSS Brake Shutdown after Loss of Grid.....	33
HSS Brake Shutdown with Generator Brake	33
Normal Tip Brake Shutdown	33
Tip Brake Shutdown after Loss of Grid	33
Accidental Deployment of a Tip Brake	33
Idling Turbine	33
Parked Turbine.....	34
Simulink Interface	35
General Description	35
Getting Started.....	35
Specific Input File Options for the FAST S-Function.....	36
Customizing the Simulink Model.....	37
Linearization	39
General Description	39
Periodic Steady State Solution.....	39
Model Linearization.....	41
Post Processing	43
ADAMS Preprocessor.....	45
General Description	45
Compiling and Linking ADAMS	45
Guidelines for Creating ADAMS Datasets	46
Running ADAMS.....	48
Description of the Extracted ADAMS Datasets	49
Input Files	53
Sample Input Files	53
Primary Input File.....	53
Tower Input File	54
Blade Input Files	54
AeroDyn Input Files.....	55
Platform Input File.....	55
Furling Input File	55
ADAMS-Specific Input File.....	55
Linearization Control-Input File	55
Output Files	93
References.....	125

FIGURES

Figure 1. Modes of Operation.	1
Figure 2. Example display output.	3
Figure 3. Tower-base coordinate system.	8
Figure 4. Tower-top/base-plate coordinate system.	8
Figure 5. Nacelle/yaw coordinate system.	8
Figure 6. Shaft coordinate system.	9
Figure 7. Hub coordinate system.	9
Figure 8. Coned coordinate system.	9
Figure 9. Blade coordinate system.	10
Figure 10. Tower mode shapes.	10
Figure 11. Blade layout.	11
Figure 12. Simple-induction-generator torque/speed curve.	11
Figure 13. Thevenin-equivalent-induction-generator torque/speed curve.	12
Figure 14. Layout of a downwind, two-bladed turbine (a) and a close-up of its hub (b).	17
Figure 15. Layout of a two-bladed rotor illustrating δ_3	18
Figure 16. Layout of a conventional, upwind, three-bladed turbine.	19
Figure 17. Layout of a three-bladed, upwind, furling turbine: furl axes.	20
Figure 18. Layout of a three-bladed, upwind, furling turbine: rotor-furl structure.	21
Figure 19. Layout of a three-bladed, upwind, furling turbine: tail-furl structure.	22
Figure 20. Support platform / foundation layout.	23
Figure 21. Flowchart of Blade Pitch Control Runtime Options.	26
Figure 22. Torque/speed curve for simple variable-speed control.	26
Figure 23. Flowchart of Variable-Speed, Generator, & HSS Brake Control Runtime Options.	28
Figure 24. Flowchart of Nacelle Yaw Control Runtime Options.	30
Figure 25. Interface to a Bladed-Style Master Controller DLL.	31
Figure 26. FAST Wind Turbine Block.	35
Figure 27. Simulink Model <i>OpenLoop.mdl</i>	36
Figure 28. Periodic Steady State Computation.	41
Figure 29. Input and Output Files.	54
Figure 30. Sample output file.	120
Figure 31. Sample linearization model file.	121
Figure 32. Sample summary file.	122
Figure 33. Sample AeroDyn options file.	124

TABLES

Table 1. FAST Source Files.	5
Table 2. User-Specified Routines.	6
Table 3. Parameter Settings to be Used With Bladed-Style Master Controller DLLs.	31
Table 4. Differences Between FAST's and Bladed's Interface to Master Controller DLLs.	32
Table 5. Control Input Settings.	43
Table 6. Wind Input Disturbance Settings.	43
Table 7. Sample Models Provided with the FAST Archive.	53

Table 8. Primary-Input-File Parameters.....	56
Table 9. Tower-Input-File Parameters.	70
Table 10. Blade-Input-File Parameters.	73
Table 11. AeroDyn-Input-File Parameters.	77
Table 12. Platform-Input-File Parameters.....	80
Table 13. Furling-Input-File Parameters.	82
Table 14. ADAMS-Specific-Input-File Parameters.....	88
Table 15. Linearization Control-Input-File Parameters.	90
Table 16. Output Parameters for Wind Motions.....	94
Table 17. Output Parameters for Blade 1 Tip Motions.....	95
Table 18. Output Parameters for Blade 2 Tip Motions.....	96
Table 19. Output Parameters for Blade 3 Tip Motions.....	98
Table 20. Output Parameters for Blade 1 Local Span Motions.....	100
Table 21. Output Parameters for Blade Pitch Motions.....	101
Table 22. Output Parameters for Teeter Motions.	101
Table 23. Output Parameters for Shaft Motions.	102
Table 24. Output Parameters for Nacelle Inertial Measurement Unit Motions.....	103
Table 25. Output Parameters for Rotor-Furl Motions.....	104
Table 26. Output Parameters for Tail-Furl Motions.....	104
Table 27. Output Parameters for Nacelle Yaw Motions.....	104
Table 28. Output Parameters for Tower-Top, Yaw-Bearing Motions.....	105
Table 29. Output Parameters for Local Tower Motions.	107
Table 30. Output Parameters for Platform Motions.	108
Table 31. Output Parameters for Blade 1 Root Loads.....	110
Table 32. Output Parameters for Blade 2 Root Loads.....	111
Table 33. Output Parameters for Blade 3 Root Loads.....	112
Table 34. Output Parameters for Blade 1 Local Span Loads.	113
Table 35. Output Parameters for Hub and Rotor Loads.	114
Table 36. Output Parameters for Shaft Strain-Gage Loads.....	115
Table 37. Output Parameters for Generator and HSS Loads.....	115
Table 38. Output Parameters for Rotor-Furl Bearing Loads.....	116
Table 39. Output Parameters for Tail-Furl Bearing Loads.....	116
Table 40. Output Parameters for Tail Fin Aerodynamic Loads.....	116
Table 41. Output Parameters for Tower-Top, Yaw-Bearing Loads.....	117
Table 42. Output Parameters for Tower Base Loads.	117
Table 43. Output Parameters for Local Tower Loads.....	118
Table 44. Output Parameters for Platform Loads.	119

FOREWORD

The FAST (Fatigue, Aerodynamics, Structures, and Turbulence) Code is a comprehensive aeroelastic simulator capable of predicting both the extreme and fatigue loads of two- and three-bladed horizontal-axis wind turbines (HAWTs). This document covers the features of FAST and outlines its operating procedures.

The FAST Code is the result of the marriage of three distinct codes; the FAST2 Code for two-bladed HAWTs; the FAST3 Code for three-bladed HAWTs; and the AeroDyn (1) aerodynamics subroutines for HAWTs. While combining these three codes, changes were made in the computational loops and in the kinematic calculations of the FAST codes. An intermediate version of FAST, called FAST_AD, used different executable files for two- and three-bladed turbines. The version of FAST documented in this report, which was developed in 2002, uses a single executable for both types of turbines. These changes resulted in a code that runs very quickly, so the code is indeed, **fast**.

In 2003, additional features were added to the FAST Code, including the ability to develop periodic linearized state matrices for controls design and the ability to use FAST as a preprocessor for generating ADAMS[®] datasets of wind turbine models ("ADAMS" is used to imply "ADAMS[®]" throughout this document). Aeroacoustic noise prediction algorithms have also been introduced.

Additional features were added to the FAST Code again in 2004. New model features added include a lateral offset and skew angle of the rotor shaft, rotor-furling, tail-furling, tail inertia and aerodynamics, yaw control, and high-speed shaft (HSS) brake control. An interface has been developed between FAST and a master controller implemented as a dynamic-link-library (DLL) in the style of Garrad Hassan's Bladed wind turbine software package (2). An interface has also been developed between FAST and Simulink[®] with MATLAB[®] ("Simulink" and "MATLAB" are used to imply "Simulink[®]" and "MATLAB[®]" throughout this document), enabling users to implement advanced turbine controls in Simulink's convenient block diagram form.

In 2005, FAST and ADAMS with AeroDyn were evaluated by Germanischer Lloyd WindEnergie and found suitable for "the calculation of onshore wind

turbine loads for design and certification" (3). Additional features were also added to the Codes. These include new nacelle inertial measurement unit and tower strain gage outputs, upgrades to the simple variable-speed control model, and new support platform motion and loading functionality. Despite the addition of six new platform motion degrees of freedom, the Code was also better-optimized so that it runs 15% faster than previous versions (or faster, depending on the options being modeled).

This manual is an updated subset of one originally written at Oregon State University (OSU) (4). The original manual included a detailed discussion of the theory behind FAST_AD (an earlier incarnation of FAST) and a validation of the code. For these two topics, please refer to the original. Also available is Buhl and others (5), which is a structural verification of FAST_AD against ADAMS. Both FAST and ADAMS use the AeroDyn subroutine set, so the structural-verification study did not provide any verification of the aerodynamics of FAST_AD. A more recent verification of FAST against ADAMS is provided in Jonkman and Buhl (6).

The Modes of Operation chapter describes the different types of analysis available in FAST and a brief description on how to run the code is provided in the Running FAST chapter. If you want to recompile FAST, you can find the information you'll need in the Compiling FAST chapter. The Model Description chapter discusses the degrees of freedom for both two- and three-bladed HAWTs. The Controls chapter documents methods for actively controlling many aspects of the turbine operation during simulation. Active controls can also be implemented in Simulink as described in the Simulink Interface chapter. The Linearization chapter documents how to extract linearized wind turbine models out of FAST. The functionality of using FAST as a preprocessor for creating ADAMS datasets is documented in the ADAMS Preprocessor chapter. The Input Files chapter describes the various program input files. Finally, the Output Files chapter lists the possible output parameters. It also describes the optional summary and element output files.

ACKNOWLEDGEMENTS

Funding for FAST development came from the U.S. Department of Energy under contract No. DE-AC36-83CH10093 to the National Renewable Energy Laboratory (NREL). Later improvements were funded by the U.S. Department of Energy under contract No. DE-AC36-98-GO10337 to NREL.

The authors would like to thank Tim Weber, Lisa Freeman, and Ross Harman of OSU; Norm Weaver of InterWeaver Consulting; and Kirk Pierce, formerly of NREL, for their past developments of FAST and FAST_AD. We would also like to thank the folks at Woodward Engineering for developing and interfacing

the AeroDyn routines that we link with the FAST structural-dynamics routines and for writing an example pitch-control routine. Tim McCoy of Global Energy Concepts and Craig Hansen of Woodward Engineering took time from their busy schedules to review drafts of this manual. Our editors, Kathy O'Dell, Ruth Baranowski, and Janie Homan, helped a lot by converting our twisted prose into readable English. Another tip of the hat goes to the many folks in the wind-energy industry who tested FAST and provided us with their valuable feedback.

UPGRADING TO FAST V6.0 FROM V5.1

This section describes how to update input files created previously for FAST v5.1 so that they are compatible with FAST v6.0. New users can skip to the section entitled Using This Manual.

FAST v6.0 contains an improvement to the simple variable-speed control model, a few upgrades and modifications to the output capabilities, and new support platform motion and loading functionality.

The simple variable-speed control model has been upgraded to include a linear transition Region 2½, in addition to the previously-available Regions 2 and 3. See the updated Variable-Speed Torque Control section of the Controls chapter and the Turbine Control section of Table 8 for more information.

You can now specify up to 5 strain gage locations along the tower for examining local tower motions and loads output, similar to what is available for blade 1. You can also specify the location in the nacelle of an inertial measurement unit (IMU)—this location is used for new nacelle motion outputs. See the Output section of Table 8 and the Output Files chapter for more information.

The new support platform motion and loading functionality represents a major expansion in the number of degrees of freedom and loading options available in FAST. Detailed information on these new features and associated inputs are presented throughout this manual where appropriate. In particular, see the Support Platform section and Figure 20 of the Model Description chapter, the Platform Input File section of the Input Files chapter, the Platform Model section of Table 8, and Table 12.

Despite the addition of six new platform motion DOFs (translational surge, sway, and heave and rotational roll, pitch and yaw), the Code was also better-optimized so that it runs 15% faster than previous versions (or faster, depending on the options being modeled).

With the addition of support platform motion functionality, it made sense to add more information to the FAST summary (*.fsm*) file. See the Output Files chapter, especially Figure 32, for more information

It also made sense to rename some of the output parameters. The output channels WindVxt, WindVyt, and WindVzt in FAST v5.1 were renamed to WindVxi, WindVyi, and WindVzi in v6.0, respectively, since the wind speeds relative to the inertia frame (i) are now more important than the wind speeds relative to the tower-base frame (t), which can now move relative to the inertia frame. WindVxi, WindVyi, and WindVzi in FAST v6.0 will give the same results as WindVxt, WindVyt, and WindVzt gave in v5.1, since

the tower-base was stationary in v5.1. See Table 16 of the Output Files chapter for more information.

The names of the output channels pertaining to the blade tip accelerations were also changed since they are now output in the local blade coordinate system instead of the undeflected coordinate system—see Table 17, Table 18, and Table 19 of the Output Files chapter for more information. The names of the output channels pertaining to the tower-top / yaw bearing angular (rotational) velocities and accelerations were also changed since they are now output in the tower-top / base-plate coordinate system instead of the tower base coordinate system—see Table 28 of the Output Files chapter for more information. These changes were made so that the associated outputs are in coordinate systems that are easier to measure in the “real world”.

Updating to FAST v6.0 from v5.1 requires a few modifications to FAST’s primary input file, even if you want to keep your turbine model configuration unchanged. Additionally, to take advantage of FAST’s new support platform motion functionality, a new file of inputs must be assembled. In addition to the changes listed below, please be aware that all of the inputs that had a lower limit restriction of –180 degrees in v5.1 were changed to **greater than** –180 degrees in FAST v6.0. This change was made since the –180 degrees (inclusive) restriction caused problems in ADAMS where the ATAN2() FUNCTION is used to initialize variables.

The changes to the primary input file are as follows (in the order they appear in the file):

- Replace inputs RatGenSp and Reg2TCon with inputs VS_RtGnSp, VS_RtTq, VS_Rgn2K, and VS_SIPc in the turbine control section. Inputs VS_RtGnSp and VS_Rgn2K are simply renamed versions of inputs RatGenSp and Reg2TCon. VS_RtTq and VS_SIPc are new inputs used to specify the rated generator torque in Region 3 and the rated generator slip percentage in Region 2½, respectively. These new inputs are needed to specify the characteristics of the improved simple variable-speed generator controller, which now includes Region 2½ in addition to Regions 2 and 3.
- Add a new platform model section including a header plus inputs PtfmModel and PtfmFile between the Thevenin-equivalent induction generator and tower sections. PtfmModel is a switch used to indicate the type of support platform as follows: {0: none, 1: onshore, 2:

fixed bottom offshore, 3: floating offshore}. If `PtfmModel` is not 0, FAST will read in an additional file of inputs for defining the model properties of the support platform. `PtfmFile` is the name of this file. In FAST v6.0, all nonzero `PtfmModel` options will work the same way by reading in `PtfmFile`. In future versions, the format of `PtfmFile` will depend on which `PtfmModel` option is selected.

- Add inputs `NclMUxn`, `NclMUyn`, and `NclMUzn` between inputs `SttsTime` and `ShftGagL` in the output section. These three new inputs define the distance from the tower-top to the nacelle inertial measurement unit in the downwind, lateral, and vertical directions, respectively.
- Add inputs `NTwGages` and `TwrGagNd` between inputs `ShftGagL` and `NBIGages` in the output section. Inputs `NTwGages` and `TwrGagNd` define the tower strain gage locations like inputs `NBIGages` and `BldGagNd` do for blade 1.

If you want to leave your model unchanged when converting to FAST v6.0, use the following equivalency relationships when defining the new inputs from the old, now obsolete, inputs:

$$VS_RtGnSp = RatGenSp$$

$$VS_RtTq = Reg2Tcon \cdot (RatGenSp^2)$$

$$VS_Rgn2K = Reg2Tcon$$

$$VS_SIPc = 9999.9E-9$$

(a very small don't care > 0.0)

$$PtfmModel = 0$$

$$PtfmFile = <may\ be\ left\ blank>$$

$$NclMUxn = 0.0 \text{ (a don't care)}$$

$$NclMUyn = 0.0 \text{ (a don't care)}$$

$$NclMUzn = 0.0 \text{ (a don't care)}$$

$$NTwGages = 0$$

$$TwrGagNd = <may\ be\ left\ blank>$$

Finally, if you use the FAST-to-ADAMS preprocessor to create ADAMS wind turbine datasets, upgrading from FAST v5.1 to v6.0 also requires you to upgrade from v12.17 to v12.18 of the ADAMS to AeroDyn (A2AD) source files and to recompile the ADAMS user-created dynamic-link-library (DLL). This is because ADAMS datasets generated using FAST v6.0 must be simulated with an ADAMS user-created DLL compiled using the source files from A2AD v12.18. All of the new features for FAST v6.0 listed above are also available in the FAST-to-ADAMS preprocessor.

UPGRADING TO FAST v5.1 FROM v5.0

This section describes how to update input files created previously for FAST v5.0 so that they are compatible with FAST v5.1. New users can skip to the section entitled Using This Manual.

FAST v5.1 contains many upgrades relating to turbine control. Yaw control features have been added to the simulation and linearization analysis modes and the ADAMS preprocessor. "Hooks" for user-defined high-speed shaft brake models have also been added to FAST and the FAST-generated ADAMS datasets. Within user-defined routines, you now have the option of switching DOFs on-or-off at runtime and you now have the ability of accessing the current value of **any** available output parameter without changing the number of arguments passed to the routines. The user-defined pitch control routine written by Craig Hansen, which is linked with the executable version of FAST, has also been upgraded. An interface has been developed between FAST and Simulink, so that you can implement advanced turbine controls in Simulink's

convenient block diagram form. An interface has also been developed between FAST and a master controller dynamic-link-library (DLL) implemented in the style of Garrad Hassan's Bladed wind turbine software package (this interface is not linked with the distributed executable, but is available as a source file containing a set of subroutines, which can be compiled with FAST in place of the built-in example control routines; the same set of routines can be used to interface FAST-generated ADAMS datasets with Bladed DLL controllers). Finally, the ramp-up of aerodynamic loads, which occurred over the first two seconds of simulation in previous versions, has been eliminated; thus, trim solutions and/or start-up transients may be different than in previous versions.

Detailed information on these new features and their associated input parameters are presented throughout this manual where appropriate. In particular, a description of yaw control is provided in the new Nacelle Yaw Control section of the Controls

chapter, user-defined high-speed shaft brake control is described in the HSS Brake Control section of the Controls chapter, master controller DLLs are described in the Master Controllers and the Bladed-Style DLL Interface section of the Controls chapter, upgrades to Craig's pitch controller should be apparent by examining the example *Pitch.ipt* input file located in FAST's *CertTest* folder, and a description of FAST's new interface to Simulink is given in the new Simulink Interface chapter.

Updating to FAST v5.1 from v5.0 requires a few modifications to FAST's primary and linearization control-input files, even if you want to keep your turbine model configuration unchanged. The changes to the primary input file are as follows (in the order they appear in the file):

- Add inputs YCMode and TYCON before PCMode. Inputs YCMode and TYCON define yaw control options like inputs PCMode and TPCOn do for pitch control.
- Change pitch control mode input PCMode so that 0 means none, 1 means user-defined from routine PitchCntrl(), and 2 means user-defined from Simulink.
- Change variable speed control mode input VSContrl so that 0 means none, 1 means simple variable speed control model, 2 means user-defined from routine UserVSCont(), and 3 means user-defined from Simulink.
- Add input HSSBrMode between TimGenOf and THSSBrDp. Input HSSBrMode provides a switch between the simple and user-defined from routine UserHSSBr() high-speed shaft brake models.
- Add inputs TYawManS, TYawManE, and NacYawF between TBDepISp(3) and TPitManS(1). Inputs TYawManS, TYawManE, and NacYawF define override yaw control options like inputs TPitManS, TPitManE, and BIPitchF do for pitch control.

The changes to the linearization control-input file are as follows (in the order they appear in the file):

- Change trim case input TrimCase so that 1 means find nacelle yaw, 2 means find generator torque (region 2 linearization), and 3 means find collective blade pitch (region 3 linearization).
- Add input NInputs before CntrlInpt. NInputs defines the number of control inputs in the output linearized state matrices.
- Change input CntrlInpt so that it is a list of control inputs from 1 to NInputs where 1 is nacelle yaw angle, 2 is nacelle yaw rate, 3 is generator torque, 4 is collective blade pitch, 5 is individual pitch of blade 1, 6 is individual pitch of blade 2, and 7 is individual pitch of blade 3.

If you want to leave your turbine model configuration unchanged when converting to FAST v5.1, use the following equivalency relationships when defining the new inputs from the old, now obsolete, inputs:

YCMode = 0

TYCon = 9999.9 (*a don't care*)

PCMode = 0 if PCMode was 0 in v5.0
= 1 if PCMode was 1 or 2 in v5.0

VSContrl = *same value as VSContrl in v5.0*

HSSBrMode = 1

TYawManS = 9999.9 (*a don't care > TMax*)

TYawManE = 9999.9 (*a don't care ≥ TYawManS*)

NacYawF = 0.0 (*a don't care*)

TrimCase = 2 if TrimCase was 1 in v5.0
= 3 if TrimCase was 2 in v5.0

NInputs = 0 if CntrlInpt was 0 in v5.0
= 1 if CntrlInpt was 1 or 2 in v5.0
= NumBl if CntrlInpt was 3 in v5.0
= 2 if CntrlInpt was 4 in v5.0
= 1 + NumBl if CntrlInpt was 5 in v5.0

CntrlInpt = *<may be left blank> if CntrlInpt was 0 in v5.0*
= 3 if CntrlInpt was 1 in v5.0
= 4 if CntrlInpt was 2 in v5.0
= 5,6 if CntrlInpt was 3 and NumBl = 2 in v5.0
= 5,6,7 if CntrlInpt was 3 and NumBl = 3 in v5.0
= 3,4 if CntrlInpt was 4 in v5.0
= 3,5,6 if CntrlInpt was 5 and NumBl = 2 in v5.0
= 3,5,6,7 if CntrlInpt was 5 and NumBl = 3 in v5.0

If you compile FAST yourself, please note that new source files *FAST_Prog.f90*, *UserVSCont_KP.f90*, and *BladedDLLInterface.f90* have been added to, and source file *PitchCntrl.f90* has been removed from, the *Source* folder in the FAST archive. Please see the new Compiling FAST chapter for more information.

Finally, if you use the FAST-to-ADAMS preprocessor to create ADAMS wind turbine datasets, upgrading from FAST v5.0 to v5.1 also requires you to upgrade from v12.16 to v12.17 of the ADAMS to AeroDyn (A2AD) source files and to recompile the

ADAMS user-created dynamic-link-library (DLL). This is because ADAMS datasets generated using FAST v5.1 must be simulated with an ADAMS user-created DLL compiled using the source files from

A2AD v12.17. All of the new features for FAST v5.1 listed above are also available in the FAST-to-ADAMS preprocessor.

UPGRADING TO FAST V5.0 FROM V4.4

FAST v5.0 contains a major expansion in the range of turbine configurations available relative to those available in FAST v4.4. This section describes how to update input files created previously for FAST v4.4 so that they are compatible with FAST v5.0. New users can skip to the section entitled Using This Manual.

New to FAST v5.0 is the availability of a lateral offset and skew angle of the rotor shaft, rotor-furling, tail-furling, and tail inertia and aerodynamics. These new features support the analysis of most small wind turbine configurations. A few new mass and inertia terms are also available for conventional turbine configurations including a yaw bearing point mass, a lateral offset for the nacelle mass, and a hub inertia for 3-bladed rotors (the hub inertia was previously available only for 2-bladed rotor configurations).

While upgrading FAST, we tried to minimize the number of changes to the input files as a courtesy to our users; nevertheless, some changes were unavoidable. Updating to FAST v5.0 from v4.4 requires a few modifications to FAST's primary and ADAMS-specific input files, even if you want to keep your turbine model configuration unchanged. Additionally, to take advantage of FAST's new model configuration properties for small wind turbines, a new file of inputs must be assembled. Detailed information on the new features and associated inputs are presented throughout this manual where appropriate. In particular, a description of the input file for specifying additional model properties for a furling turbine is provided in Table 13.

The changes to the primary input file are as follows (in the order they appear in the file):

- Remove input `TiltDOF`.
- Remove input `NacTilt`.
- Replace inputs `ParaDnm` and `PerpDnm` with inputs `NacCMxn`, `NacCMyn`, and `NacCMzn`. These three new inputs define the distance from the tower-top to the nacelle mass center in the downwind, lateral, and vertical directions, respectively. This is in contrast to how `ParaDnm` and `PerpDnm` previously located the nacelle mass center relative to the rotor shaft.
- Add input `ShftTilt` between inputs `TwrRBHt` and `Delta3`. `ShftTilt` defines the rotor shaft

tilt angle, replacing what used to be input `NacTilt`.

- Add input `YawBrMass` before `NacMass`. `YawBrMass` defines the point mass of the yaw bearing.
- Remove input `NacTIner`.
- Replace the entire nacelle-tilt section, which includes the header plus inputs `TiltSpr`, `TiltDamp`, `TiltSstP`, `TiltHstP`, `TiltSSSp`, and `TiltHSSp`, with a furling section, which includes a header plus inputs `Furling` and `FurlFile`. `Furling` is a flag used to tell FAST whether or not to read in an additional file of inputs for defining the model configuration of a furling turbine. `FurlFile` is the name of this file.

The changes to the ADAMS-specific input file are as follows (in the order they appear in the file):

- Add input `LSSLength` between inputs `HSSLength` and `GenRad`. `LSSLength` defines the length of the low-speed shaft cylinder used for LSS graphical output in ADAMS. This is in contrast to how the LSS previously extended from the hub to the yaw axis.
- Remove inputs `TetPnLngh` and `TeetPinRad`. These inputs were deemed unnecessary graphical output in ADAMS.
- Add input `BoomRad` after input `ThkOvrChrd` at the end of the file. `BoomRad` defines the radius of the tail boom cylinder used for tail boom graphical output in ADAMS.

If you want to leave your turbine model configuration unchanged when converting to FAST v5.0, use the following equivalency relationships when defining the new inputs from the old, now obsolete, inputs:

$$\text{NacCMxn} = \text{ParaDnm} \cdot \cos(\text{NacTilt}) - \text{PerpDnm} \cdot \sin(\text{NacTilt})$$

$$\text{NacCMyn} = 0.0$$

$$\text{NacCMzn} = \text{ParaDnm} \cdot \sin(\text{NacTilt}) + \text{PerpDnm} \cdot \cos(\text{NacTilt}) + \text{Twr2Shft}$$

$$\text{ShftTilt} = \text{NacTilt}$$

YawBrMass = 0.0

Furling = False

FurlFile = *<may be left blank>*

LSSLength = ABS(OverHang)

BoomRad = 0.0

Note that the above equations are only applicable if your existing FAST v4.4 model had the nacelle-tilt degree of freedom disabled (TiltDOF = False). If your existing FAST v4.4 model had the nacelle-tilt degree of freedom enabled (TiltDOF = True)*, you will now need to assemble the FurlFile in order to define the model properties of your tilting turbine. This is because the nacelle-tilt degree of freedom has been replaced with the more general rotor-furl degree of freedom.

Finally, if you use the FAST-to-ADAMS preprocessor to create ADAMS wind turbine datasets, upgrading from FAST v4.4 to v5.0 also requires you to upgrade from v12.15 to v12.16 of the ADAMS to AeroDyn (A2AD) source files and to recompile the ADAMS user-created dynamic-link-library (DLL). This is because ADAMS datasets generated using FAST v5.0 must be simulated with an ADAMS user-created DLL compiled using the source files from A2AD v12.16. All of the new features for FAST v5.0 listed above are also available in the FAST-to-ADAMS preprocessor.

* The only example, known by the authors, of a wind turbine with a tilting-nacelle degree of freedom is the Wind Eagle 300 turbine from Cannon Wind Eagle Corporation.

USING THIS MANUAL

We use several typographic conventions in this manual to make it easy to distinguish various entities. Most titles and headings are formatted with the **Arial bold** typeface. This manual uses the Times New Roman typeface for body text. To make it easy to spot **Variable Names** within the body text, we formatted them with the **Arial** typeface. We did the same for routine names but appended a pair of parentheses to the end of the name (for example, **Routine()**). We formatted file names with *Times New Italic* so that we wouldn't have to deal with the awkward situation of having to include punctuation within the quote marks, which might cause confusion. Examples are formatted with the **Letter Gothic** typeface.

MODES OF OPERATION

FAST has two different forms of operation or analysis modes (see Figure 1). Switch `AnalMode` in the primary input file is used to control this mode.

The first analysis mode is time-marching of the nonlinear equations of motion—that is, **simulation**. During simulation, wind turbine aerodynamic and structural response to wind-inflow conditions is determined in time. Active controls for determining many aspects of the turbine operation may be implemented during simulation analyses as described in the Controls chapter. Outputs of simulations include time-series data on the aerodynamic loads as well as loads and deflections of the structural members of the wind turbine as described in the Output Files chapter. These outputs can be used, for example, to predict both the extreme and fatigue loads of HAWTs. The aerocoustic signature of an operating turbine is another output that can be obtained from simulation.

Simulation analyses can be run using the distributed Windows executable program file or as a dynamic-link-library (DLL) interfaced with Simulink. When running the executable version of FAST, active controls must be implemented through user-defined routines that have been linked with FAST during creation of the executable or as a master controller implemented as a DLL in the style of Garrad Hassan's Bladed wind turbine software package. When running FAST as a DLL interfaced with Simulink, active controls can be implemented in the Simulink environment in addition to the implementations available with the FAST executable. Most of the contents of this manual relate to simulation using the FAST executable; there is no chapter in this manual devoted specifically to this mode of operation. The Simulink Interface chapter documents how to run

simulations using FAST as a DLL interfaced with Simulink.

The second form of analysis provided in FAST is **linearization**. FAST has the capability of extracting linearized representations of the complete nonlinear aeroelastic wind turbine modeled in FAST. This analysis capability is useful for developing state matrices of a wind turbine “plant” to aid in controls design and analysis. It is also useful for determining the full system modes of an operating or stationary HAWT through the use of a simple eigenanalysis. The Linearization chapter documents how to extract linearized wind turbine models out of FAST. The linearization capability is only available in the Windows executable version (not the DLL interface with Simulink).

Another feature available in FAST is the ADAMS preprocessor. The ADAMS preprocessor feature is separate from the two analysis modes available in FAST. It is not considered an analysis mode of FAST, because it does not make use of the aeroelastic wind turbine model available in FAST. Instead, the ADAMS preprocessor uses the input parameters available in the FAST input files to construct an ADAMS dataset of a complete aeroelastic wind turbine. ADAMS then becomes the code in which different wind turbine analyses (simulation or linearization) are performed. The ADAMS preprocessor feature of FAST is documented, not surprisingly, in the ADAMS Preprocessor chapter of this manual and is controlled by switch `ADAMSPrep` in FAST’s primary input file. The ADAMS preprocessor capability is only available in the Windows executable version (not the DLL interface with Simulink).

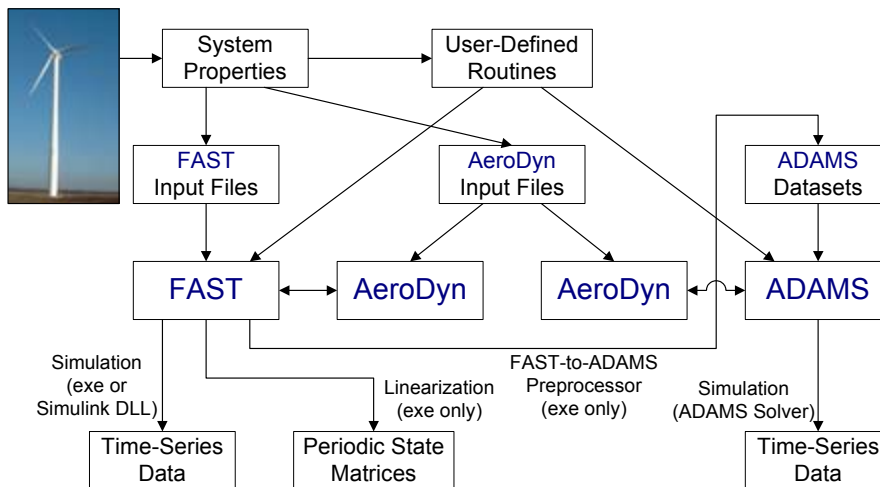

Figure 1. Modes of Operation.

RUNNING FAST

This section documents how to run the FAST Windows executable program file that we distribute in the FAST archive available at our Web page <http://wind.nrel.gov/designcodes/simulators/fast/>. For a description on how to run FAST with Simulink, see the Simulink Interface chapter.

Before you run FAST, you will want to install it in such a way that you can run it from any folder. For instructions on installing codes such as FAST, please read Buhl (7).

To run the executable, open a command prompt window in the directory in which you want to work. The command-line syntax is:

```
fast [/h] [<input file>]
```

where:

`/h` prints a help message.
`<input file>` is the name of the primary input file. The default name is *primary.fst*).

When FAST runs, it first prints out a line informing you of the version and compile date of the code. If it cannot find the input file, it aborts with an error message. If it finds a valid input file, FAST

echoes the title line from the input file. If aerodynamic calculations are requested in your input file, the AeroDyn routines then print out some startup messages. If running a time-marching analysis, next, you will see one line that is repeatedly overwritten telling you what the status of the simulation is. It will update this line periodically.

At the end of the simulation, FAST prints out some run-time statistics as seen in Figure 2. The *Total Real Time* is the amount of time passed from the time you started the program to the time it completes. The *Total CPU Time* is a measure of the computer time used for the entire FAST run, which includes the time it takes to read in the input files and set up the model. The difference between these two times is the amount of time your computer was busy with other things while running FAST. The *Simulation Time* is the amount of time simulated. The *Simulation CPU Time* is the amount of computer time use during that time-marching part of the simulation. The *Simulation Time Ratio* is the ratio of the amount of time simulated to the simulation CPU time. The bigger this number is, the faster your computer is. If the value is greater than 1, then FAST can simulate an event in less time than it would take in real life. If the value is less than 1, then it might be time to upgrade your computer ☺.

```
Running FAST (v4.00, 09-Jul-2002).

FAST certification test #1 for AWT-27CR2 with many
DOFs.

Heading of the aerodyn.ipt file :
AWT-27CR aerodynamic parameters for FAST certification
test #01.

Detected hub-height wind file:
"Wind/Shr12_30.wnd"

Aerodynamics loads calculated using AeroDyn(12.46, 23-
May-2002)

Total Real Time:          7.141 seconds
Total CPU Time:           7.1406 seconds
Simulation Time:          20 seconds
Simulation CPU Time:      7.1094 seconds
Simulation Time Ratio:    2.8132

FAST completed normally.
```

Figure 2. Example display output.

COMPILING FAST

You should not need to compile FAST unless you want to create and link a user-defined routine, make changes to the source code, or port FAST to an operating system other than Microsoft Windows. The FAST Windows executable program file that we distribute in the archive can be used for all other purposes.

You must include both FAST's and AeroDyn's source files in a workspace in order to compile FAST. AeroDyn's source code, which is available in the AeroDyn archive, is available for download from our Web page <http://wind.nrel.gov/designcodes/simulators/aerodyn/>. All of the FAST source code resides in the *Source* folder of the FAST archive. The FAST Windows executable program file that we distribute in the FAST archive is compiled using the Compaq Visual Fortran (CVF) Standard Edition compiler version 6.6.B. Table 1 lists the FAST source files used to compile this program file.

When compiling using CVF, we have the Debugging Level set to "Minimal", the Warning Level set to "Normal Warnings", and the Optimization Level set to "Full Optimizations". We also use Project Options `/assume:byterecl`, `/compile_only`, `/nologo`, `/stand`, `/traceback`, and `/warn:nofileopt`. We recommend that you use the same compiler and project options when compiling FAST using the CVF compiler.

All of the CVF compiler-dependent code in FAST resides in the files called *SysCVF.f90* and *ModCVF.f90*. (AeroDyn also contains some CVF compiler-dependent code) If you want to port FAST to another platform or compiler, you should have to change only these two files. Also included in the *Source* folder are files *SysLL.f90*, *ModLL.f90*, *SysLU.f90*, and *ModLU.f90*. Files *SysLL.f90* and *ModLL.f90* should be used when compiling FAST in Lahey Linux (LL). Files *SysLU.f90* and *ModLU.f90* should be used when compiling FAST in Lahey Unix (LU). In the FAST archive, we also distribute a file named *make_LL*. This is a makefile that was developed by Hugh Currin who used it to compile an older version of FAST (v4.03) in LL. Please be aware that the NWTC does not have an LL or LU compiler, and as such, we have not been able to update the LL and LU source files and LL makefile to accommodate upgrades to the program. Nevertheless, these sample files should be a useful starting point if you need to port FAST to another operating system.

Table 1. FAST Source Files.

Source File	Description
<i>FAST_Prog.f90</i>	Contains PROGRAM FAST(), which guides the program's execution
<i>FAST_Mods.f90</i>	Contains MODULEs that store variables used by FAST's routines
<i>FAST_IO.f90</i>	Contains routines related to program input and output
<i>FAST.f90</i>	Contains routines that make-up the "guts" of FAST, including the equations of motion and their solution
<i>AeroCalc.f90</i>	Contains the interface routines between FAST and AeroDyn
<i>FAST2ADAMS.f90</i>	Contains routines that make up the FAST-to-ADAMS preprocessor
<i>FAST_Lin.f90</i>	Contains routines used during a linearization analysis
<i>SetVersion.f90</i>	Contains a routine that sets the program version number
<i>GenUse.f90</i>	Contains general-purpose routines
<i>NoiseMods.f90</i>	Contains a MODULE that stores variables used by the aeroacoustic routines
<i>NoiseSubs.f90</i>	Contains routines related to aeroacoustics
<i>ModCVF.f90</i>	Contains a MODULE that stores compiler-dependent variables
<i>SysCVF.f90</i>	Contains compiler-dependent routines
<i>UserSubs.f90</i>	Contains dummy placeholders of all available user-specified routines
<i>PitchCntrl_ACH.f90</i>	Contains an example pitch control routine written by A. Craig Hansen
<i>UserVSCont_KP.f90</i>	Contains an example variable-speed torque control routine written by Kirk Pierce

FAST includes "hooks" for ten user-specified routines as summarized in Table 2. Dummy placeholder versions of these routines are all contained within source file *UserSubs.f90*.

Table 2. User-Specified Routines.

Routine	Description
PitchCntrl()	User-specified blade pitch control (either independent or rotor-collective) model
UserGen()	User-specified generator torque and power model
UserHSSBr()	User-specified high-speed shaft brake model
UserPtfmLd()	User-specified platform loading model
UserRFrl()	User-specified rotor-furl spring / damper model
UserTeet()	User-specified rotor-teeter spring / damper model
UserTFin()	User-specified tail fin aerodynamics model
UserTFrl()	User-specified tail-furl spring / damper model
UserVSCont()	User-specified variable-speed torque and power control model
UserYawCont()	User-specified nacelle-yaw control model

In order to interface FAST with your own user-specified routines, you can develop your own logic within these dummy placeholders and recompile FAST, **or** comment out the appropriate dummy placeholders, create your own routines in their own source files, and recompile FAST while linking in these additional source files. For example, as implied

in Table 1, the executable version of FAST that is distributed with the archive is linked with the example `PitchCntrl()` routine contained in source file `PitchCntrl_ACH.f90` and the example `UserGen()` and `UserVSCont()` routines contained in source file `UserVSCont_KP.f90`. Thus, the dummy placeholders for routines `PitchCntrl()`, `UserGen()`, and `UserVSCont()` are commented out within source file `UserSubs.f90`. The example pitch controller was written by A. Craig Hansen (ACH) and the example generator and variable speed controllers were written by Kirk Pierce (KP). Please see the aforementioned source files for additional information on these example user-specified routines.

Also contained in the *Source* folder is a file named `BladedDLLInterface.f90`. This source file contains example `PitchCntrl()`, `UserHSSBr()`, `UserVSCont()`, and `UserYawCont()` routines that may be used to interface FAST with a master controller implemented as a dynamic-link-library (DLL) in the style of Garrad Hassan's Bladed wind turbine software package (2). In order to compile FAST with these routines, you must comment-out the dummy placeholder versions of routines `PitchCntrl()`, `UserHSSBr()`, `UserVSCont()`, and `UserYawCont()` contained in source file `UserSubs.f90` and recompile FAST with the addition of source file `BladedDLLInterface.f90`. The executable version of FAST that is distributed with the FAST archive is **not** linked with the routines contained within source file `BladedDLLInterface.f90`. Please see the Master Controllers and the Bladed-Style DLL Interface section of the Controls chapter for more information.

MODEL DESCRIPTION

General Description

The FAST code can model the dynamic response of both two- and three-bladed, conventional, horizontal-axis wind turbines. The wind turbine configuration may optionally include rotor-furling, tail-furling, and tail aerodynamics—features useful in the analysis of most small wind turbines. The code was evaluated by Germanischer Lloyd WindEnergie and found suitable for "the calculation of onshore wind turbine loads for design and certification" (3).

The FAST model employs a combined modal and multibody dynamics formulation. The model for two-bladed turbines relates nine rigid bodies (earth, support platform, base plate, nacelle, armature, gears, hub, tail, and structure furling with the rotor) and four flexible bodies (tower, two blades, and drive shaft) through 22 degrees of freedom (DOFs). Accounted for in the degrees of freedom are platform translation and rotation (6 DOF), tower flexibility (4 DOF), nacelle yaw (1 DOF), variable generator and rotor speeds (2 DOF), blade teetering (1 DOF), blade flexibility (6 DOF), rotor-furl (1 DOF), and tail-furl (1 DOF). Flexibility in the blades and tower are characterized using a linear modal representation that assumes small deflections. The three rotational DOFs of the support platform (roll, pitch, and yaw) also employ a small angle approximation. The remaining DOFs may exhibit large displacements without loss of accuracy. The DOFs are further described below.

The first six DOFs (the most recent additions) originate from the translational (surge, sway, and heave) and rotational (roll, pitch, and yaw) motions of the support platform relative to the inertia frame.

Two DOFs originate from the first bending mode of the tower in the longitudinal and transverse directions. Two more DOFs model the second bending mode in the same directions. The tower is rigidly attached to the support platform through a cantilever connection.

Another DOF accounts for the nacelle yaw motion, which can be free or fixed with a torsional yaw spring. The rotor can be either upwind or downwind with the rotor providing yaw loads.

The next DOF accounts for variations in generator speed. Another DOF accounts for drivetrain flexibility associated with torsional motion between the generator and the hub/rotor.

Another DOF accounts for teeter motion of the blades about a pin located on the hub. Dampers, springs, or a combination of both can restrict teeter motion.

The next two DOFs arise from the first flapwise bending mode of each blade. Two more DOFs originate from the second flapwise bending modes. Blade edgewise motion accounts for the next two DOFs. The blades are rigidly attached to the hub through a cantilever connection. Motion of the blades is along the local principal axes. See the discussion of blade mode shapes in the Flexible Tower and Blades section on page 10 for details.

The last two DOFs are associated with furling of the rotor and tail about the yawing-portion of the structure atop the tower. The rotor-furl DOF can also be used to model torsional flexibility in the gearbox mounting if you align the rotor-furl axis with the rotor shaft axis. The amount of furling motion can be restricted with springs, dampers, or a combination of both.

The FAST code can also model a three-bladed HAWT with 24 DOFs. The first six DOFs originate from the translational (surge, sway, and heave) and rotational (roll, pitch, and yaw) motions of the support platform relative to the inertia frame. The next four DOFs account for tower motion; two are longitudinal modes, and two are lateral modes. Yawing motion of the nacelle provides another DOF. The next DOF is for the generator azimuth angle, and another DOF is for the compliance in the drivetrain between the generator and hub/rotor. These DOFs account for variable rotor speed and drive-shaft flexibility. The next three DOFs are the blade flapwise tip motion for the first mode. Three more DOFs give the tip displacement for each blade for the second flapwise mode. The next three DOFs are for the blade edgewise tip displacement for the first edgewise mode. The last two DOFs are for rotor- and tail-furl.

For both the two- and three-bladed wind turbine configurations, you can enable any combination of the available DOFs and features during your analysis. The DOFs and features most applicable to you are dictated by the configuration of the wind turbine you are analyzing.

Coordinate Systems

Figure 3 through Figure 9 show the coordinate systems used for input and output parameters. Coordinate systems t , n , h , and b conform to the International Electrotechnical Commission (IEC) standard for wind turbines (8). Additional coordinate systems i , p , a , s , and c are necessary for interpreting some of the output parameters. Some of the coordinate systems used internally by FAST differ from these. FAST takes care of these conversions for you.

Inertial Frame Coordinate System

- Origin** The point about which the translational motions of the support platform (surge, sway, and heave) are defined.
- x_i axis** Pointing in the nominal (0°) downwind direction.
- y_i axis** Pointing to the left when looking in the nominal downwind direction.
- z_i axis** Pointing vertically upward opposite to gravity.

Tower-Base Coordinate System

This coordinate system is fixed in the support platform so that it translates and rotates with the platform.

- Origin** Intersection of the center of the tower and the tower base connection to the support platform.
- x_t axis** When the support platform has no pitch or yaw displacement, it is aligned with the x_i axis (pointing horizontally in the nominal downwind direction).
- y_t axis** When the support platform has no roll or yaw displacement, it is aligned with the y_i axis (pointing to the left when looking in the nominal downwind direction).
- z_t axis** Pointing up from the center of the tower.

When you request output of motions or loads for various locations along the tower with the TwrGagNd array, a local coordinate system similar to the standard tower system is used, but the local coordinate systems orient themselves with the deflected tower.



Figure 3. Tower-base coordinate system.

Tower-Top/Base-Plate Coordinate System

This coordinate system is fixed to the top of the tower. It translates and rotates as the platform moves

and the tower bends, but it does not yaw with the nacelle.

- Origin** A point on the yaw axis at a height of TowerHt above ground level [onshore or mean sea level [offshore] (see Figure 14(a), Figure 16, or Figure 20).
- x_p axis** When the tower is not deflected, it is aligned with the x_i axis.
- y_p axis** When the tower is not deflected, it is aligned with the y_i axis.
- z_p axis** When the tower is not deflected, it is aligned with the z_i axis. It is also the yaw axis.

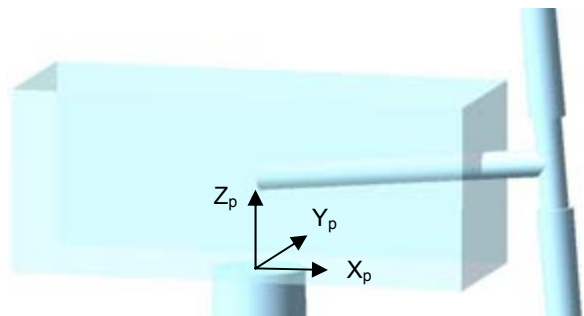

Figure 4. Tower-top/base-plate coordinate system.

Nacelle/Yaw Coordinate System

This coordinate system translates and rotates with the top of the tower, plus it yaws with the nacelle.

- Origin** The origin is the same as that for the tower-top/base-plate coordinate system.
- x_n axis** Pointing horizontally toward the nominally downwind end of the nacelle.
- y_n axis** Pointing to the left when looking toward the nominally downwind end of the nacelle.
- z_n axis** Coaxial with the tower/yaw axis and pointing up.

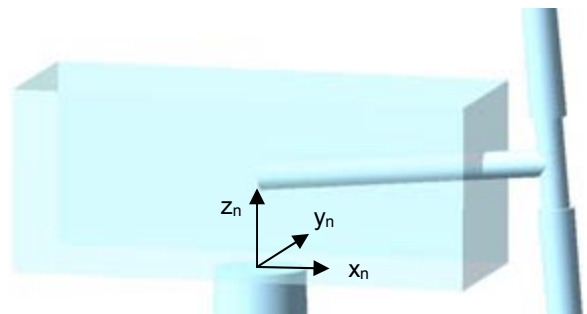

Figure 5. Nacelle/yaw coordinate system.

Shaft Coordinate System

The shaft coordinate system does not rotate with the rotor, but it does translate and rotate with the tower and it yaws with the nacelle and furls with the rotor. The nacelle inertial measurement unit uses this coordinate system for all of its motion outputs. Shaft bending moments at the hub and at the position denoted by `ShftGagL` use this coordinate system or the rotating hub coordinate system shown below.

- Origin** Intersection of the y_n - z_n -plane and the rotor axis.
- x_s axis** Pointing along the (possibly tilted) shaft in the nominally downwind direction.
- y_s axis** Pointing to the left when looking from the tower toward the nominally downwind end of the nacelle.
- z_s axis** Orthogonal with the x_s and y_s axes such that they form a right-handed coordinate system.

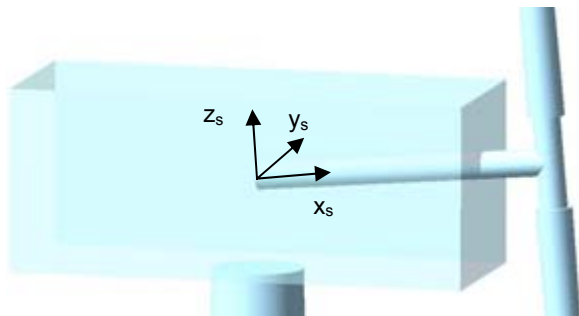

Figure 6. Shaft coordinate system.

Azimuth Coordinate System

The azimuth, or a , coordinate system is located at the origin of the shaft coordinate system, but it rotates with the rotor. When Blade 1 points up, the azimuth and shaft coordinate systems are parallel. For three-bladed rotors, blade 3 is ahead of blade 2, which is ahead of blade 1, so that the order of blades passing through a given azimuth is 3-2-1-repeat.

Hub Coordinate System

The hub coordinate system rotates with the rotor. It also teeters in two-bladed models.

- Origin** Intersection of the rotor axis and the plane of rotation (non-coned rotors) or the apex of the cone of rotation (coned rotors).
- x_h axis** Pointing along the hub centerline in the nominal downwind direction.
- y_h axis** Orthogonal with the x_h and z_h axes such that they form a right-handed coordinate system.
- z_h axis** Perpendicular to the hub centerline with the same azimuth as Blade 1.

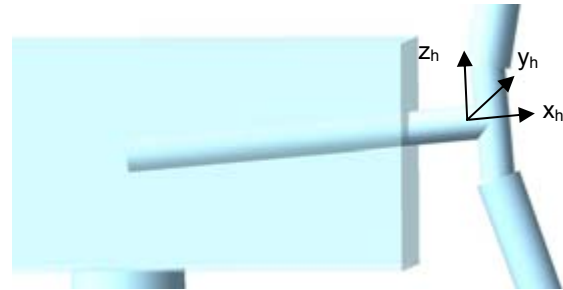

Figure 7. Hub coordinate system.

Coned Coordinate Systems

There is a coned coordinate system for each blade that rotates with the rotor. The coordinate system does not pitch with the blades and it also teeters in two-bladed models. For three-bladed rotors, blade 3 is ahead of blade 2, which is ahead of blade 1, so that the order of blades passing through a given azimuth is 3-2-1-repeat.

- Origin** The origin is the same as that for the hub coordinate system.
- $x_{c,i}$ axis** Orthogonal with the $y_{c,i}$ and $z_{c,i}$ axes such that they form a right-handed coordinate system. ($i = 1, 2, \text{ or } 3$ for blades 1, 2, or 3, respectively)
- $y_{c,i}$ axis** Pointing towards the trailing edge of blade i if the pitch and twist were zero and parallel with the chord line. ($i = 1, 2, \text{ or } 3$ for blades 1, 2, or 3, respectively)
- $z_{c,i}$ axis** Pointing along the pitch axis towards the tip of blade i . ($i = 1, 2, \text{ or } 3$ for blades 1, 2, or 3, respectively)



Figure 8. Coned coordinate system.

Blade Coordinate Systems

These coordinate systems are the same as the coned coordinate systems, except that they pitch with the blades and their origins are at the blade root. For three-bladed rotors, blade 3 is ahead of blade 2, which is ahead of blade 1, so that the order of blades passing through a given azimuth is 3-2-1-repeat.

- Origin Intersection of the blade's pitch axis and the blade root.
- $x_{b,i}$ axis Orthogonal with the y_b and z_b axes such that they form a right-handed coordinate system. ($i = 1, 2, \text{ or } 3$ for blades 1, 2, or 3, respectively)
- $y_{b,i}$ axis Pointing towards the trailing edge of blade i and parallel with the chord line at the zero-twist blade station. ($i = 1, 2, \text{ or } 3$ for blades 1, 2, or 3, respectively)
- $z_{b,i}$ axis Pointing along the pitch axis towards the tip of blade i . ($i = 1, 2, \text{ or } 3$ for blades 1, 2, or 3, respectively)

When you request output of motions or loads for various span locations along the blade with the `BldGagNd` array, a local coordinate system similar to the standard blade system, but the x-axis and y-axis are aligned with the local principal axes and the local coordinate systems orient themselves with the deflected blade.

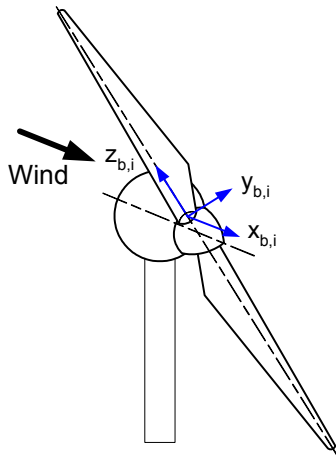

Figure 9. Blade coordinate system.

Turbine Layout

Figure 14 and Figure 15 show the layout of a conventional, downwind, two-bladed turbine and Figure 16 shows the layout of a conventional, upwind, three-bladed turbine. Figure 17 through Figure 19 show the layout of an upwind turbine with both rotor- and tail-furling. Figure 20 shows the layout of the support platform regardless of the above ground [onshore] or above water [offshore] configuration. These figures also include some of the important input dimensions. For definitions of these parameters, please see the Turbine Configuration section of Table 8 on page 61 for nonfurling turbines, the same section of Table 13 on page 82 for furling turbines, and the same section of Table 12 on page 81 for the support platform.

Flexible Tower and Blades

FAST models flexible elements, such as the tower and blades, using a linear modal representation. The reliability of this representation depends on the generation of accurate mode shapes, which are input into FAST. You can use a program called Modes (9) to generate these shapes and copy its output to your FAST input file. Modes uses essentially the same structural data as FAST. Although the tower and blade input files include flags to calculate the mode shapes internally, we have not implemented this feature in the code.

For the tower, you will need to know the tower-top mass to run Modes. If you do not know the tower-top mass, you can obtain it by first running FAST with a rigid tower and with dummy mode shapes, and then reading the summary output file, which includes the tower-top mass (see Figure 32 on page 122). FAST allows you to specify four different mode shapes for the tower. The two fore-aft modes are defined separately from the two side-to-side modes. The mode shapes take the form of a sixth-order polynomial with the zeroth and first terms always being zero. This is because the mode shapes are cantilevered at the base so they must have zero deflection and slope there. At the top of the tower, where the normalized height is 1, the deflection must have a normalized value of 1. This means the sum of the polynomial coefficients must add to 1. See Figure 10 for a graphic example of tower mode shapes.

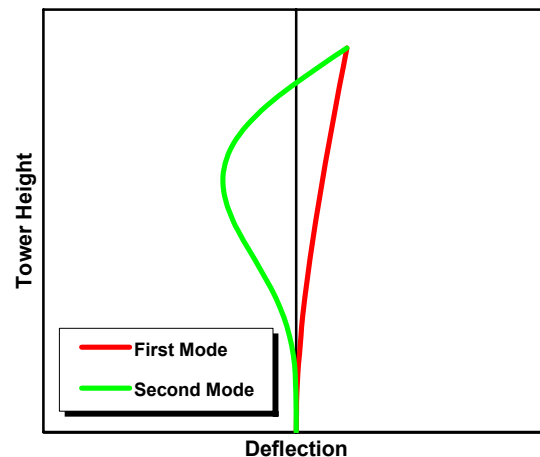

Figure 10. Tower mode shapes.

The blade mode shapes are defined in a way similar to that of the tower. For the blades, FAST can use two flapwise modes and one edgewise mode. The modes are defined with respect to the local structural twist, that is, the shapes twist with the blade, are three-dimensional, and do not lie within a single plane. In the case of a twisted blade, the tip will deflect in both the in-plane and out-of-plane directions due to a pure

flapwise deflection. The edgewise mode works in a similar fashion. When generating blade modes for a variable-speed turbine, you should choose a typical rotor speed for the cases you will simulate when generating the mode shapes. Usually, the rotor speed has little effect on the mode shapes, but it will have a significant effect on the frequency of vibration. Still, you may want to generate multiple mode shapes for different rotor speeds to see whether there is a significant impact on the results.

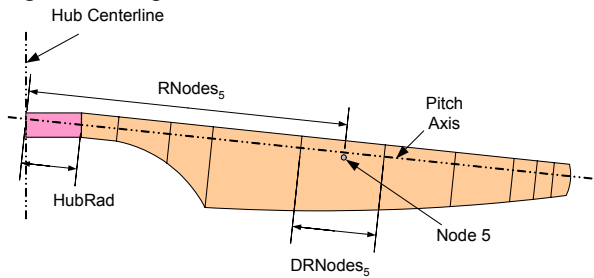

Figure 11. Blade layout.

Drivetrain

The drivetrain is modeled as an equivalent shaft separating the generator from the hub. The shaft can have a linear torsional spring and a linear torsional damper. Use the drivetrain DOF flag, `DrTrDOF`, to enable this feature. The equation governing the restoring torque of the spring/damper is:

$$T_{res} = DTTorSpr \cdot (RotorPos - GboxPos) + DTTorDmp \cdot (RotorSpeed - GboxSpeed)$$

The constants `DTTorSpr` and `DTTorDmp` are the equivalent torsional stiffness and damping constants for the combined low-speed shaft (LSS), gearbox, and high-speed shaft (HSS). All values used in this equation are cast on the LSS side of the gearbox.

You can simulate losses of the torque being transmitted through the gearbox by setting the gearbox efficiency, `GBoxEff`, to some value less than 100%. When generating power, FAST will multiply the LSS torque by the efficiency and divide by the gearbox ratio to determine HSS torque. When motoring, FAST will multiply the HSS torque by the efficiency and gearbox ratio to compute the torque on the LSS.

Generator

The generator flag, `GenDOF`, also governs the behavior of the drivetrain, with several options available. Disabling it will force the generator side of the shaft to turn at a constant speed.

You can control when to start the generator with the `GenTiStr` flag in conjunction with either `SpdGenOn` or `TimGenOn`. If `GenTiStr` is True, the generator torque will be zero until `TimGenOn`.

Otherwise, the generator torque will be zero until the generator speed reaches `SpdGenOn`.

You can control when to stop the generator with the `GenTiStp` flag in conjunction with `TimGenOf`. If `GenTiStp` is True, the generator torque will be set to zero after `TimGenOf`. Otherwise, the generator will stay on until its power reaches zero. Once the generator is turned off by either method, it will stay off until the end of the simulation. If you are not going to simulate a shutdown or a loss of grid, set `GenTiStp` to True and `TimGenOf` to a value greater than `TMax`. Please see the Simulation Special Events section in the Controls chapter for more information about this subject.

Enabling `GenDOF` will also invoke one of several generator models. The choice of the model is determined by the setting of the `GenModel` switch or the `VSContrl` switch. Unless the `VSContrl` switch is 0, `GenModel` will be ignored. Please see the Variable-Speed Torque Control section in the Controls chapter for more information on the variable-speed control options.

If you set `VSContrl` to 0 and `GenModel` to 1, FAST will use the simple induction generator model. This model uses just four parameters: rated generator slip percentage (`SIG_SIPc`), the synchronous (zero-torque) generator speed (`SIG_SySp`), the rated torque (`SIG_RtTq`), and the pullout ratio (`SIG_PORT`). This results in the torque/speed curve seen in Figure 12. In the chart, the rated rotor speed, Ω_R , is derived from the synchronous speed and the slip percent:

$$\Omega_R = SIG_SySp \cdot (1 + 0.01 \cdot SIG_SIPc)$$

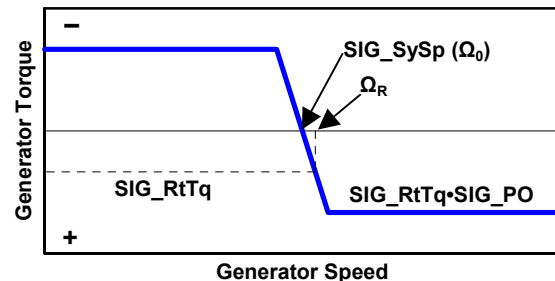

Figure 12. Simple-induction-generator torque/speed curve.

The simple model is really too simple to use for a turbine startup. Instead, set `VSContrl` to 0 and `GenModel` to 2 to invoke the more-accurate generator model that uses the Thevenin Equivalent Circuit equations for a three-phase induction generator. This model uses eight input parameters. These values are input in engineering units instead of using the per-unit values (normalized by base values) often found in

generator specification sheets. FAST's Thevenin-equivalent equations assume a Y-connected, three-phase-generator configuration. If you have a delta-connected configuration, you must divide your impedances by three and your voltage by $\sqrt{3}$ to convert the values to a Y-connected configuration. Table 8 includes a detailed description of the input parameters and an example torque/speed curve can be seen in Figure 13.

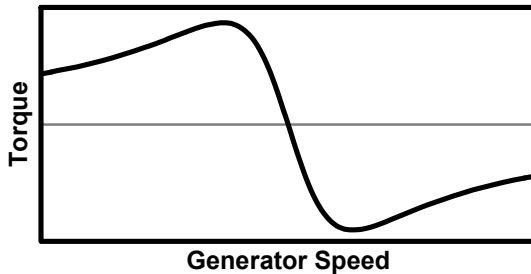

Figure 13. Thevenin-equivalent-induction-generator torque/speed curve.

Users can create their own generator model by modifying the supplied dummy subroutine `UserGen()` available (but commented out) in the `UserSubs.f90` source file. To use your own generator model, it will be necessary to compile the modified file and link it with the rest of the code. FAST will call `UserGen()` if you set `VSCntrl` to 0 and `GenModel` to 3. The `UserGen()` routine linked with the distributed executable version of FAST, which is supplied in source file `UserVSCntrl_KP.f90`, currently calls subroutine `UserVSCntrl()`, so that setting `GenModel` to 3 causes FAST to behave as if `VSCntrl` is set to 2. The routine that calls `UserGen()` passes the HSS speed and expects the electrical generator torque and electrical power to be returned. But within routine `UserGen()`, you have the ability to access the current value of **any** output parameter available from FAST without changing the number of arguments passed to the routine. Also, you have the option of switching the generator DOF on-or-off at runtime within `UserGen()` by overriding input `GenDOF`. Please see the supplied dummy routines in `UserSubs.f90` and the Controls chapter for further details.

You can simulate generator losses by setting the generator efficiency, `GenEff`, to some value less than 100%. When generating power, FAST will multiply the mechanical generator power by the efficiency to determine electrical generator power. When motoring, FAST will multiply the electrical generator power by the efficiency to compute the mechanical generator power. FAST does not use the generator efficiency for the Thevenin model since the Thevenin model incorporates a more complex expression for the electrical power based on the input circuit resistances.

The flowchart provided in Figure 23 of the Controls chapter explains how the program uses the generator model input parameters during runtime, as described above. In this flowchart, `GenTq` is the instantaneous electrical generator torque, `GenPwr` is the instantaneous electrical generator power, and `GenSpeed` is the instantaneous HSS (generator) speed. The additional logic presented in the flowchart explains how the program uses the variable-speed torque and HSS brake control input parameters during runtime.

Nacelle Yaw

FAST can model nacelle yaw as a perfect hinge with no resistance forces by setting `YawDOF` to True and the yaw spring constant, `YawSpr`, and the yaw damping constant, `YawDamp`, to zero. You can also model a free-yaw machine with yaw damping by setting `YawDamp` to a nonzero value.

You can model the flexibility and damping in the yaw drive of a yaw-driven turbine whose commanded yaw position is held **constant**, by setting `YawDOF` to True, `YCMODE` to 0, and `YawSpr` and `YawDamp` to a nonzero value. FAST will use input parameter `YawNeut` as the neutral yaw position (i.e., constant yaw command) and `NacYaw` as the initial yaw angle. In this case, the torque transmitted through the yaw bearing, `YawMom`, is:

$$\text{YawMom} = \text{YawSpr} \cdot (\text{YawPos} - \text{YawNeut}) + \text{YawDamp} \cdot \text{YawRate}$$

where `YawPos` is the instantaneous yaw position.

For a fixed-yaw simulation, set `YawDOF` to False, `YCMODE` to 0, `TYawManS` greater than `TMax`, and `NacYaw` to the fixed nacelle yaw angle.

You can also actively control the nacelle-yaw motion during a simulation. Please see the Nacelle Yaw Control section in the Controls chapter for information on active yaw control options.

Rotor-Furl

The rotor-furl DOF allows you to model the unusual configuration of a bearing that permits the rotor and drivetrain to rotate about the yawing-portion of the structure atop the tower. The rotor-furl DOF can alternatively be used to model torsional flexibility in the gearbox mounting if you align the rotor-furl axis with the rotor shaft axis. In order to include rotor-furling in your model, you must designate the turbine as a furling machine by setting input `Furling` from the primary input file to True. Then you must assemble the furling input file, `FurlFile`, and use the rotor-furl flag, `RFrIDOF`, to enable this feature.

The angular rotor-furl motion takes place about the rotor-furl axis defined by inputs `RFrIPntxn`, `RFrIPntyln`, `RFrIPntzn`, `RFrISkew`, and `RFrITilt`

available in `FurlFile`. Inputs `RFrlPntxn`, `RFrlPntyn`, and `RFrlPntzn` locate an arbitrary point on the rotor-furl axis relative to the tower-top. Inputs `RFrlSkew` and `RFrlTilt` then define the angular orientation of the rotor-furl axis passing through this point. See Figure 17 for a schematic.

The rotor-furl bearing can be an ideal bearing with no friction by setting `RFrlMod` to 0; by setting `RFrlMod` to 1, it also has a standard model that includes a linear spring, linear damper and Coulomb damper, as well as up- and down-stop springs, and up- and down-stop dampers. FAST models the stop springs with a linear function of rotor-furl deflection. The rotor-furl stops start at a specified angle and work as a linear spring based on the deflection past the stop angles. The rotor-furl dampers are linear functions of the furl rate and start at the specified up-stop and down-stop angles. These dampers are bidirectional, resisting motion equally in both directions once past the stop angle.

A user-defined rotor-furl spring and damper model is also available. To use it, set `RFrlMod` to 2 and create a subroutine entitled `UserRFrl()` with the parameters `RFrlDef`, `RFrlRate`, `DirRoot`, `ZTime`, and `RFrlMom`:

<code>RFrlDef</code> :	Current rotor-furl angular deflection in radians (input)
<code>RFrlRate</code> :	Current rotor-furl angular rate in rad/sec (input)
<code>ZTime</code> :	Current simulation time in sec (input)
<code>DirRoot</code> :	Simulation root name including the full path to the current working director (input)
<code>RFrlMom</code> :	Rotor-furl moment in N·m (output)

The source file `UserSubs.f90` contains a dummy `UserRFrl()` routine; replace it with your own and rebuild FAST. Within routine `UserRFrl()` you have the option of switching the rotor-furl DOF on-or-off at runtime by overriding input `RFrlDOF`. You can also access the current value of **any** output parameter available from FAST without changing the number of arguments passed to the routine. Please see the dummy `UserRFrl()` routine for a description of how to take advantage of these incredibly flexible features. Parameter `DirRoot` may be used to write a record of what is done in `UserRFrl()` to be stored with the simulation results.

The geometries of the hub and rotor-furl structure mass center, which are both components of the furling-rotor assembly, are defined relative to the tower-top as shown in Figure 18. This definition was chosen in order to avoid having to define a coordinate system in the furling-rotor assembly since such a coordinate system would most likely have an obscure orientation, making it difficult for users to input configuration information relative to it. This definition also avoids

the complications involved in having to define geometries differently, depending on whether or not a rotor-furl assembly exists separately from the nacelle, which depends on whether rotor-furl is present or absent in the turbine. The developers of FAST also believe that defining geometry relative to the tower-top is the most standard convention. For instance, analysts usually think of the rotor shaft offset as the lateral distance between the rotor shaft axis and the yaw axis (input `Yaw2Shft` in FAST), not as a distance relative to some coordinate system in the structure furling with the rotor.

Since the component geometry of the furling-rotor assembly is defined relative to the tower-top, this geometry naturally changes with the rotor-furl angle. In order to avoid having to define different geometries for different rotor-furl positions (for example, variations in the initial rotor-furl angle), FAST expects the component geometry of the furling-rotor assembly to be defined/input at a rotor-furl angle of zero. As such, the initial rotor-furl angle does not affect the specification of any other rotor-furl geometry. Stated another way, the input geometries for the rotor-furl assembly components define the rotor configuration when the rotor-furl angle is zero regardless of initial rotor-furl position. Users should be clear of this convention when assembling their furling input file.

Defining the geometry of the rotor-furl structure relative to the tower-top instead of in some coordinate system inherent in the furling-rotor assembly also has some undesirable consequences. The following example will highlight a drawback to the input convention used in FAST and, at the same time, illustrate how the convention works. Consider the case of a small wind turbine company who has settled on the rotor-furl assembly configuration, including the location of the rotor-furl bearing attachment point on this assembly, but has yet to determine the best location of the rotor-furl axis with respect to the yawing portion of the structure atop the tower. If the design analyst wants to test the rotor-furl response at several different rotor-furl axis locations, this will require him/her to alter not just one input parameter (i.e., the rotor furl axis point) but several input parameters collectively. For instance, if he/she wants to alter the lateral (y_n) location of the rotor-furl axis, this will require him/her to shift inputs `RFrlPntyn`, `RfrlCMyN`, and `Yaw2Shft` by the same amount since shifting the rotor-furl axis relative to the tower-top also shifts the rotor-furl assembly.

Tail-Furl

The tail-furl DOF allows you to model the unusual configuration of a bearing that permits the tail to rotate about the yawing-portion of the structure atop the tower. In order to include tail-furling in your model, you must designate the turbine as a furling machine by

setting input `Furling` from the primary input file to `True`. Then you must assemble the furling input file, `FurlFile`, and use the tail-furl flag, `TFrIDOF`, to enable this feature.

The angular tail-furl motion takes place about the tail-furl axis defined by inputs `TFrIPntxn`, `TFrIPntyn`, `TFrIPntzn`, `TFrISkew`, and `TFrITilt` available in `FurlFile`. Inputs `TFrIPntxn`, `TFrIPntyn`, and `TFrIPntzn` locate an arbitrary point on the tail-furl axis relative to the tower-top. Inputs `TFrISkew` and `TFrITilt` then define the angular orientation of the tail-furl axis passing through this point. See Figure 17 for a schematic.

The tail-furl bearing can be an ideal bearing with no friction by setting `TFrIMod` to 0; by setting `TFrIMod` to 1, it also has a standard model that includes a linear spring, linear damper and Coulomb damper, as well as up- and down-stop springs, and up- and down-stop dampers. FAST models the stop springs with a linear function of tail-furl deflection. The tail-furl stops start at a specified angle and work as a linear spring based on the deflection past the stop angles. The tail-furl dampers are linear functions of the furl rate and start at the specified up-stop and down-stop angles. These dampers are bidirectional, resisting motion equally in both directions once past the stop angle.

A user-defined tail-furl spring and damper model is also available. To use it, set `TFrIMod` to 2 and create a subroutine entitled `UserTFrI()` with the parameters `TFrIDef`, `TFrIRate`, `ZTime`, `DirRoot`, and `TFrIMom`:

<code>TFrIDef:</code>	Current tail-furl angular deflection in radians (input)
<code>TFrIRate:</code>	Current tail-furl angular rate in rad/sec (input)
<code>ZTime:</code>	Current simulation time in sec (input)
<code>DirRoot:</code>	Simulation root name including the full path to the current working director (input)
<code>TFrIMom:</code>	Tail-furl moment in N·m (output)

The source file `UserSubs.f90` contains a dummy `UserTFrI()` routine; replace it with your own and rebuild FAST. Within routine `UserTFrI()` you have the option of switching the tail-furl DOF on-or-off at runtime by overriding input `TFrIDOF`. You can also access the current value of **any** output parameter available from FAST without changing the number of arguments passed to the routine. Please see the dummy `UserTFrI()` routine for a description of how to take advantage of these incredibly flexible features. Parameter `DirRoot` may be used to write a record of what is done in `UserTFrI()` to be stored with the simulation results.

The geometries of the tail boom mass center, tail fin mass center, and tail fin aerodynamic surface,

which are all components of the furling-tail assembly, are defined relative to the tower-top as shown in Figure 19. This definition was chosen in order to avoid having to define a coordinate system in the furling-tail assembly since such a coordinate system would most likely have an obscure orientation, making it difficult for users to input configuration information relative to it. This definition also avoids the complications involved in having to define geometries differently, depending on whether or not a tail-furl assembly exists separately from the nacelle, which depends on whether tail-furl is present or absent in the turbine.

Since the component geometry of the furling-tail assembly is defined relative to the tower-top, this geometry naturally changes with the tail-furl angle. In order to avoid having to define different geometries for different tail-furl positions (for example, variations in the initial tail-furl angle), FAST expects the component geometry of the furling-tail assembly to be defined/input at a tail-furl angle of zero. As such, the initial tail-furl angle does not affect the specification of any other tail-furl geometry. Stated another way, the input geometries for the tail-furl assembly components define the tail configuration when the tail-furl angle is zero regardless of initial tail-furl position. Users should be clear of this convention when assembling their furling input file. Further clarification on this furling geometry convention is provided in the Rotor-Furl section above.

Rotor-Teeter

For two-bladed turbines, FAST can model a teetering rotor. To enable the teeter DOF, set `TeetDOF` to `True`.

The teeter bearing can be an ideal bearing with no friction by setting `TeetMod` to 0; by setting `TeetMod` to 1, it also has a standard model that includes a spring, stop, and damper. FAST models the spring with a linear function of teeter deflection. The teeter stop starts at a specified angle and works as a linear spring based on the deflection past the stop angle. The teeter damper is a linear function of teeter rate that starts at a specified angle.

A user-defined teeter-spring and damper model is also available. To use it, set `TeetMod` to 2 and create a subroutine entitled `UserTeetI()` with the parameters `TeetDef`, `TeetRate`, `ZTime`, `DirRoot`, and `TeetMom`:

<code>TeetDef:</code>	Current teeter deflection in radians (input)
<code>TeetRate:</code>	Current teeter rate in rad/sec (input)
<code>ZTime:</code>	Current simulation time in sec (input)
<code>DirRoot:</code>	Simulation root name including the full path to the current working director (input)
<code>TeetMom:</code>	Teeter moment in N·m (output)

The source file *UserSubs.f90* contains a dummy `UserTeet()` routine; replace it with your own and rebuild FAST. Within routine `UserTeet()` you have the option of switching the rotor-teeter DOF on-or-off at runtime by overriding input `TeetDOF`. You can also access the current value of **any** output parameter available from FAST without changing the number of arguments passed to the routine. Please see the dummy `UserTeet()` routine for a description of how to take advantage of these incredibly flexible features. Parameter `DirRoot` may be used to write a record of what is done in `UserTeet()` to be stored with the simulation results.

FAST also allows you to specify a δ_3 angle for the teeter hinge. By teetering about an angle that is not perpendicular to the blades, you can introduce flap/pitch coupling to your rotor. This is thought to add aerodynamic restoring forces to the blade. Positive δ_3 will cause the leading edge of the downwind-most blade to feather into the wind. This is illustrated in Figure 15. See Malcolm's paper (10) for an analysis of δ_3 .

Support Platform

You can model the support platform in an onshore foundation, fixed bottom offshore foundation, or floating offshore configuration by setting the value of input switch `PtfmModel` from the primary input file to 1, 2, or 3, respectively. Setting `PtfmModel` to 0 disables the platform models—in this case, FAST will rigidly attach the tower to the inertia frame (ground) through a cantilever connection.

The support platform model properties are designated using the input parameters available in the platform input file, `PtfmFile`. In FAST v6.0, all nonzero `PtfmModel` options work the same way by reading in `PtfmFile`. In future versions, the format of this file will depend on which `PtfmModel` option is selected.

A layout of the configuration properties available for the support platform is given in Figure 20. The platform reference point, located by input parameter `PtfmRef`, is the origin in the platform about which the translational (surge, sway, and heave) and rotational (roll, pitch, and yaw) motions of the support platform are defined. It is also the point at which external loading is applied to the platform.

In FAST v6.0, only user-defined platform loading is available. For a value of 0 for `PtfmLdMod` (available in `PtfmFile`), there will be no platform loading and the support reactions normally produced will be set to zero (causing the wind turbine to fall due to gravity if `PtfmHvDOF` is True).

If you set `PtfmLdMod` to 1, FAST will call a user defined routine named `UserPtfmLd()` to compute the platform loading. The platform loads returned by `UserPtfmLd()` should contain contributions from any

external load acting on the platform other than loads transmitted from the wind turbine. For example, these loads should contain contributions from foundation stiffness and damping [not floating] or mooring line restoring and damping [floating], as well as hydrostatic and hydrodynamic contributions [offshore]. The platform loads will be applied on the platform at the instantaneous platform reference position (located by input `PtfmRef`).

To use this feature, set `PtfmLdMod` to 1 and create a subroutine entitled `UserPtfmLd()` with the parameters `X(6)`, `XD(6)`, `ZTime`, `DirRoot`, `PtfmAM(6,6)`, and `PtfmFt(6)`:

- `X(6)`: A vector of size 6 containing the 3 components of the current platform translational displacement in meters and the 3 components of the current platform rotational displacement in radians (input)
- `XD(6)`: A vector of size 6 containing the 3 components of the current platform translational velocity in m/sec and the 3 components of the current platform rotational (angular) velocity in rad/sec (input)
- `ZTime`: Current simulation time in sec (input)
- `DirRoot`: Simulation root name including the full path to the current working director (input)
- `PtfmAM(6,6)`: A **symmetric** matrix of size 6 X 6 containing the current added mass matrix of the platform with units of kg, kg·m and kg·m² (output)
- `PtfmFt(6)`: A vector of size 6 containing 3 translational and 3 rotational components of the current portion of the platform load, with units of N and N·m, associated with everything but the added mass effects (output)

As implied by the outputs above, the routine assumes that the platform loads are transmitted through a medium like soil [foundation] and/or water [offshore], so that added mass effects are important. Consequently, the routine assumes that the total platform load can be written as:

$$\text{PtfmF}(i) = \text{SUM}(-\text{PtfmAM}(i,j) \cdot \text{XDD}(j), j = 1, 2, \dots, 6) + \text{PtfmFt}(i) \quad (\text{for } i = 1, 2, \dots, 6)$$

where,

- `PtfmF(i)`: The i^{th} component of the total load applied on the platform; positive in the direction of positive motion of the i^{th} DOF of the platform
- `PtfmAM(i,j)`: The (i,j) component of the platform added mass matrix

- XDD(j): The j^{th} component of the platform acceleration vector
- PtfmFt(i): The i^{th} component of the portion of the platform load associated with everything but the added mass effects; positive in the direction of positive motion of the i^{th} DOF of the platform

The order of indices in all arrays passed to and from routine `UserPtfmLd()` is as follows:

- 1 = Platform surge / x_1 -component of platform translation
- 2 = Platform sway / y_1 -component of platform translation
- 3 = Platform heave / z_1 -component of platform translation
- 4 = Platform roll / x_2 -component of platform rotation
- 5 = Platform pitch / y_2 -component of platform rotation
- 6 = Platform yaw / z_2 -component of platform rotation

The source file `UserSubs.f90` contains a dummy `UserPtfmLd()` routine; replace it with your own and rebuild FAST. Within routine `UserPtfmLd()` you have the option of switching the platform DOFs on-or-off at runtime by overriding inputs `PtfmSgDOF`, `PtfmSwDOF`, `PtfmHvDOF`, `PtfmRDOF`, `PtfmPDOF`, and `PtfmYDOF`. You can also access the current value of **any** output parameter available from FAST without changing the number of arguments passed to the routine. Please see the dummy `UserPtfmLd()` routine for a description of how to take advantage of these incredibly flexible features. Parameter `DirRoot` may be used to write a record of what is done in `UserPtfmLd()` to be stored with the simulation results.

When using `UserPtfmLd()`, please note that the hydrostatic restoring contribution to the hydrodynamic force returned by the routine should **not** contain the effects of body weight, as is often done in classical marine hydrodynamics. The effects of body weight are included within FAST and ADAMS.

Rotor Aerodynamics

The `AeroDyn` aerodynamic subroutine library supplies the aerodynamics algorithms for the rotor. Although we include descriptions of the parameters in the `AeroDyn` input file in Table 11, please refer to the `AeroDyn User's Guide (1)` for most of the details on this package. Input flag `CompAero` can be used to disable aerodynamics calculations while debugging a model.

Tail Fin Aerodynamics

Your model can optionally include tail fin aerodynamic loads. In order to include them, you must designate the turbine as a furling machine by setting input `Furling` from the primary input file to `True` and then assemble the furling input file, `FurlFile`. A furling model may also exclude tail fin aerodynamic loads by setting `TFinMod` in `FurlFile` to 0.

You can choose to invoke a simple tail fin aerodynamics model built into FAST by setting `TFinMod` to 1. By accessing information from `AeroDyn`, this model computes the relative velocity of the wind-inflow and its angle of attack relative to the tail fin chordline and uses an `AeroDyn` airfoil table chosen by the user (`TFinNFoil`) to determine the lift and drag forces acting at the tail fin center-of-pressure. Set `SubAxInD` to `False` if you want the wind velocity at the tail fin to be unobstructed by the rotor wake. Set `SubAxInD` to `True` if you want FAST to decrease (i.e., subtract) the wind velocity at the tail fin center-of-pressure by the average rotor induced velocity in the rotor shaft direction.

You also have the option of implementing far more sophisticated tail fin aerodynamics models by supplying your own routines that can easily be linked with the rest of FAST. To do this, set `TFinMod` to 2 and create a subroutine entitled `UserTFin()`. The source file `UserSubs.f90` contains a dummy `UserTFin()` routine; replace it with your own and rebuild FAST. The routine that calls `UserTFin()` passes the tail-furl angle and rate and tail-fin center-of-pressure location and velocity and expects the angle of attack, lift and drag coefficients, local dynamic pressure, as well as the normal and tangential forces to be returned. But within routine `UserTFin()`, you have the ability to access the current value of **any** output parameter available from FAST without changing the number of arguments passed to the routine. Please see the supplied dummy routine in `UserSubs.f90` for further details.

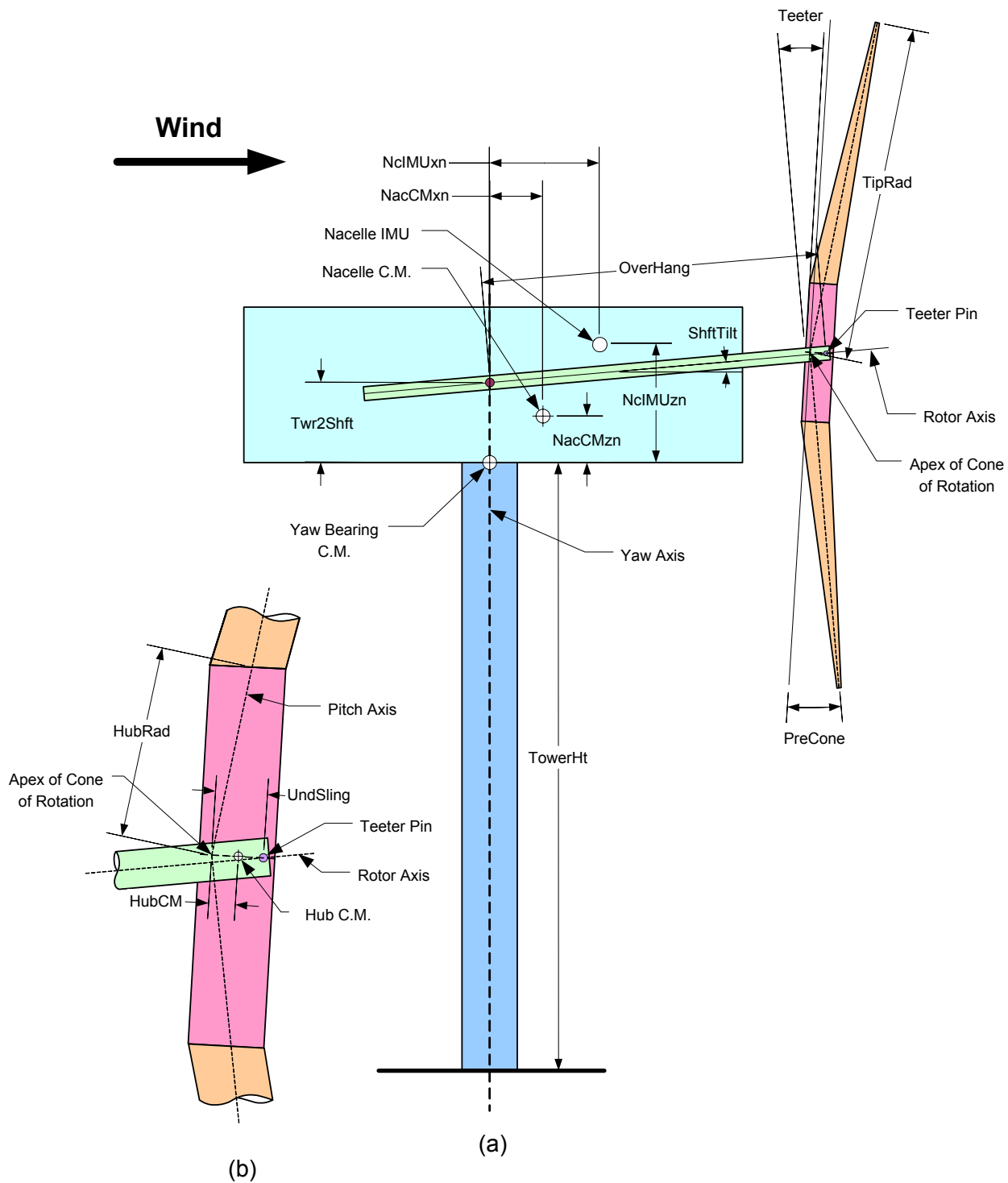

Figure 14. Layout of a downwind, two-bladed turbine (a) and a close-up of its hub (b).

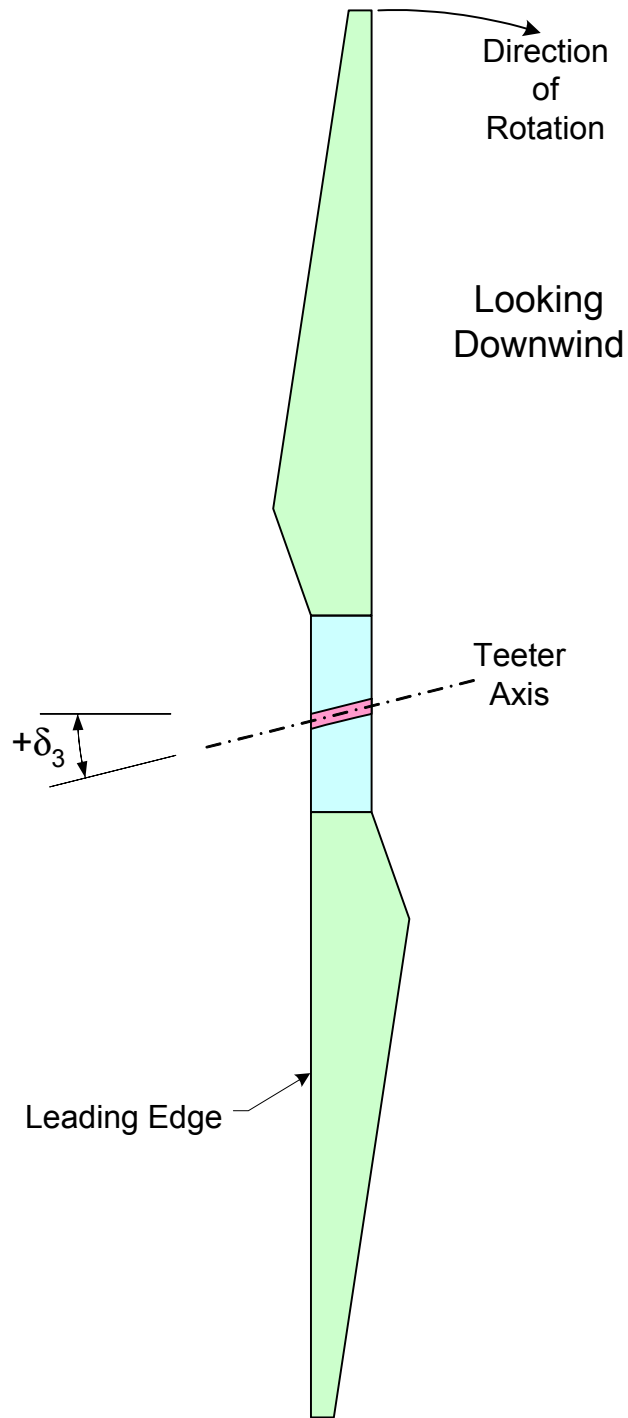

Figure 15. Layout of a two-bladed rotor illustrating δ_3 .

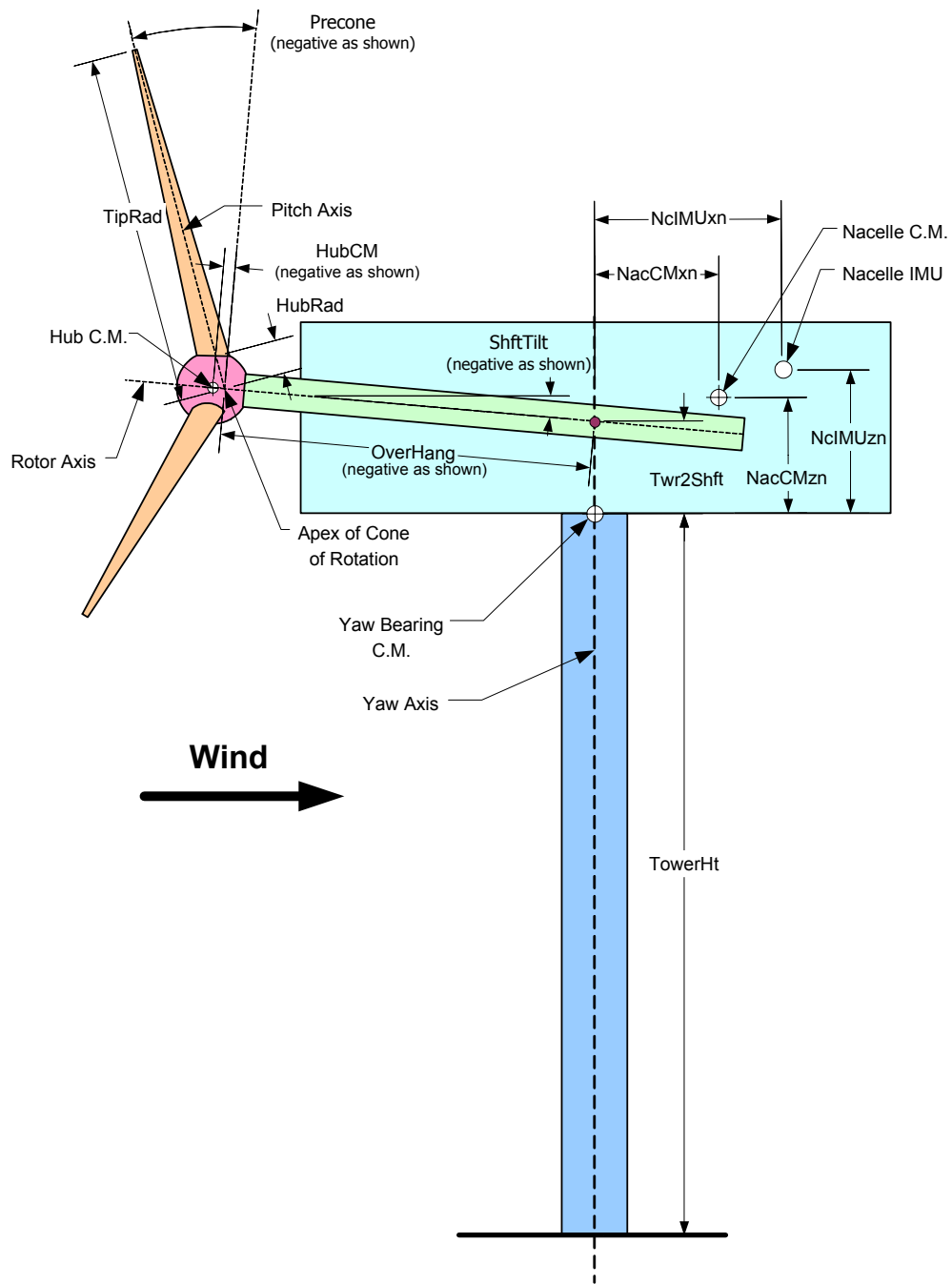

Figure 16. Layout of a conventional, upwind, three-bladed turbine.

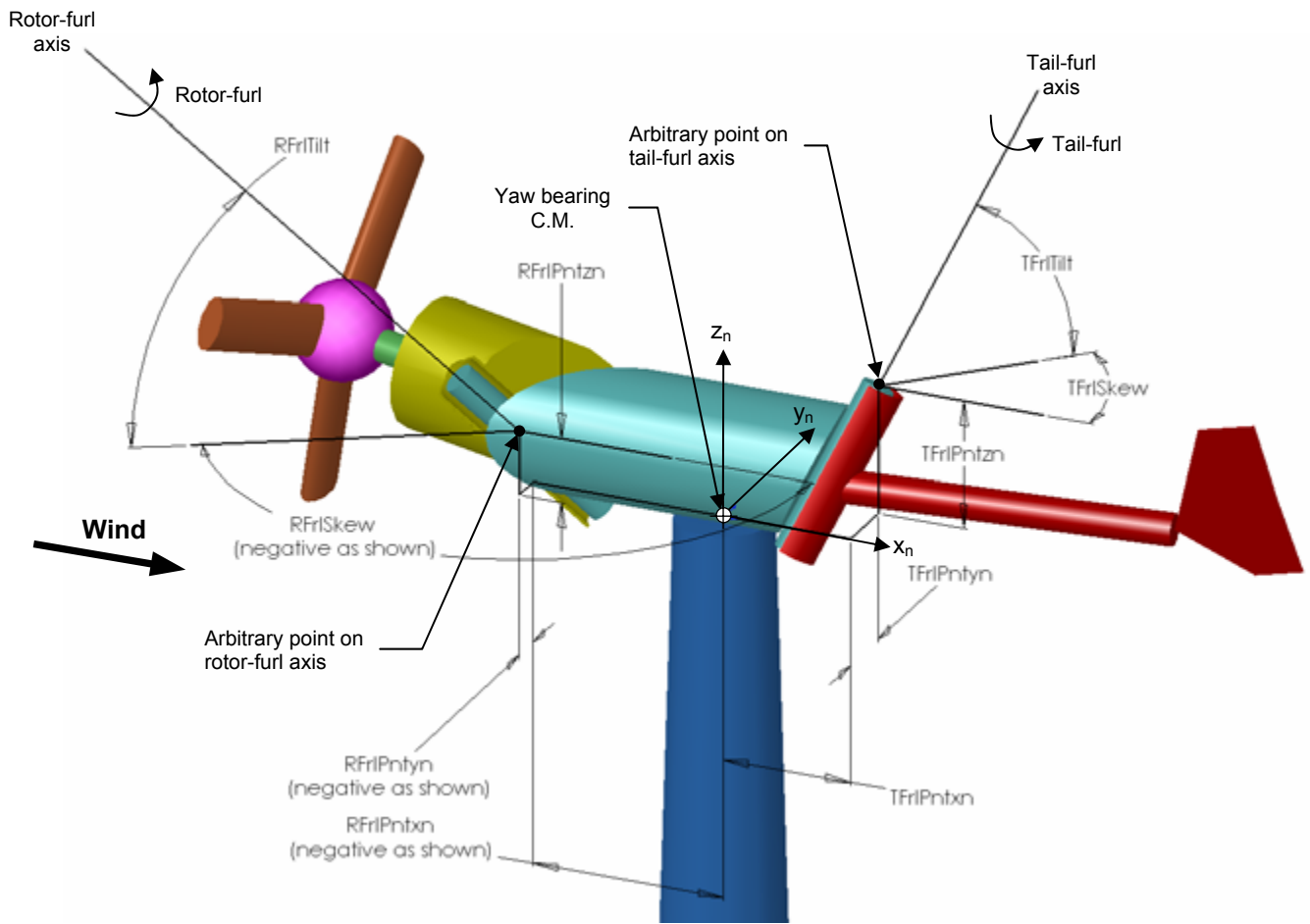

Figure 17. Layout of a three-bladed, upwind, furling turbine: furl axes.

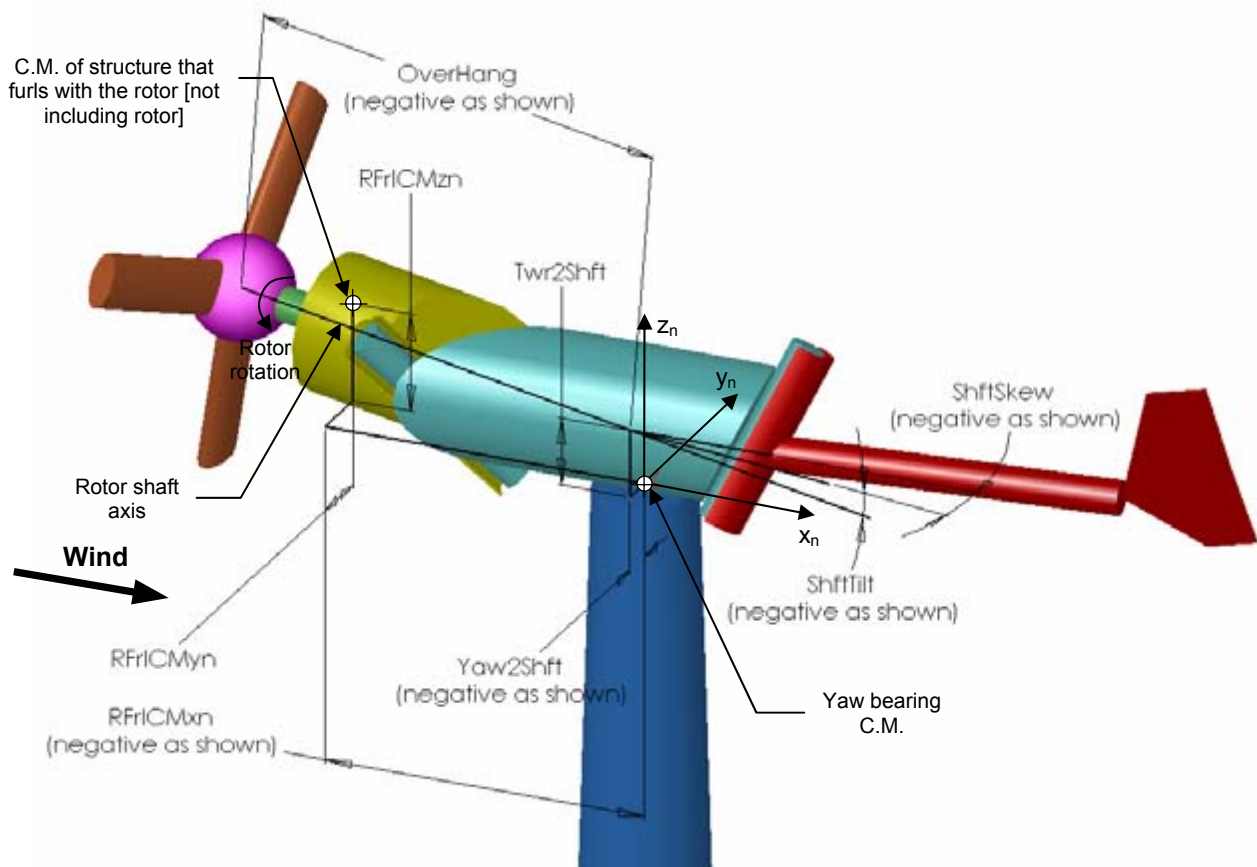

Figure 18. Layout of a three-bladed, upwind, furling turbine: rotor-furl structure

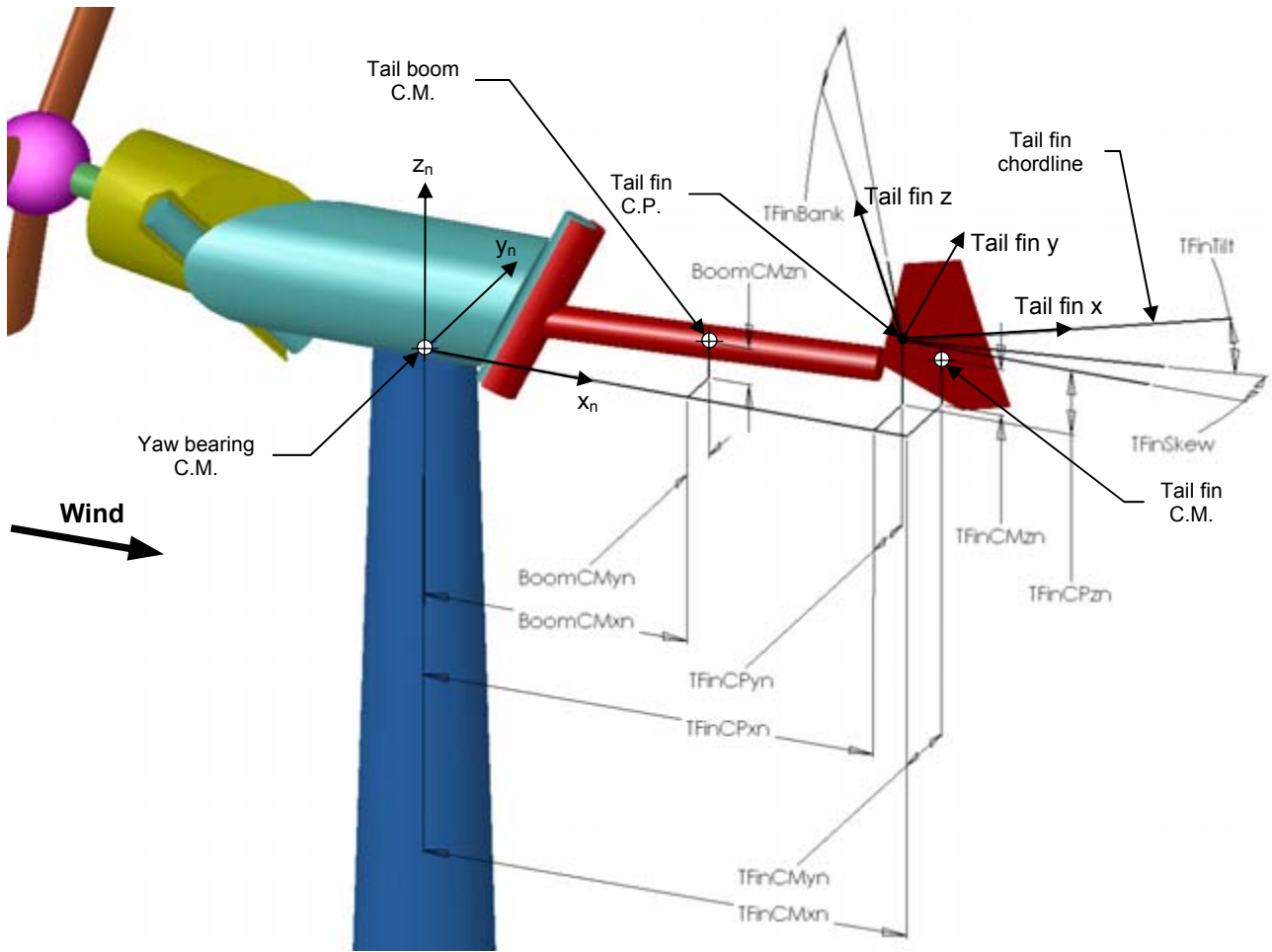

Figure 19. Layout of a three-bladed, upwind, furling turbine: tail-furl structure.

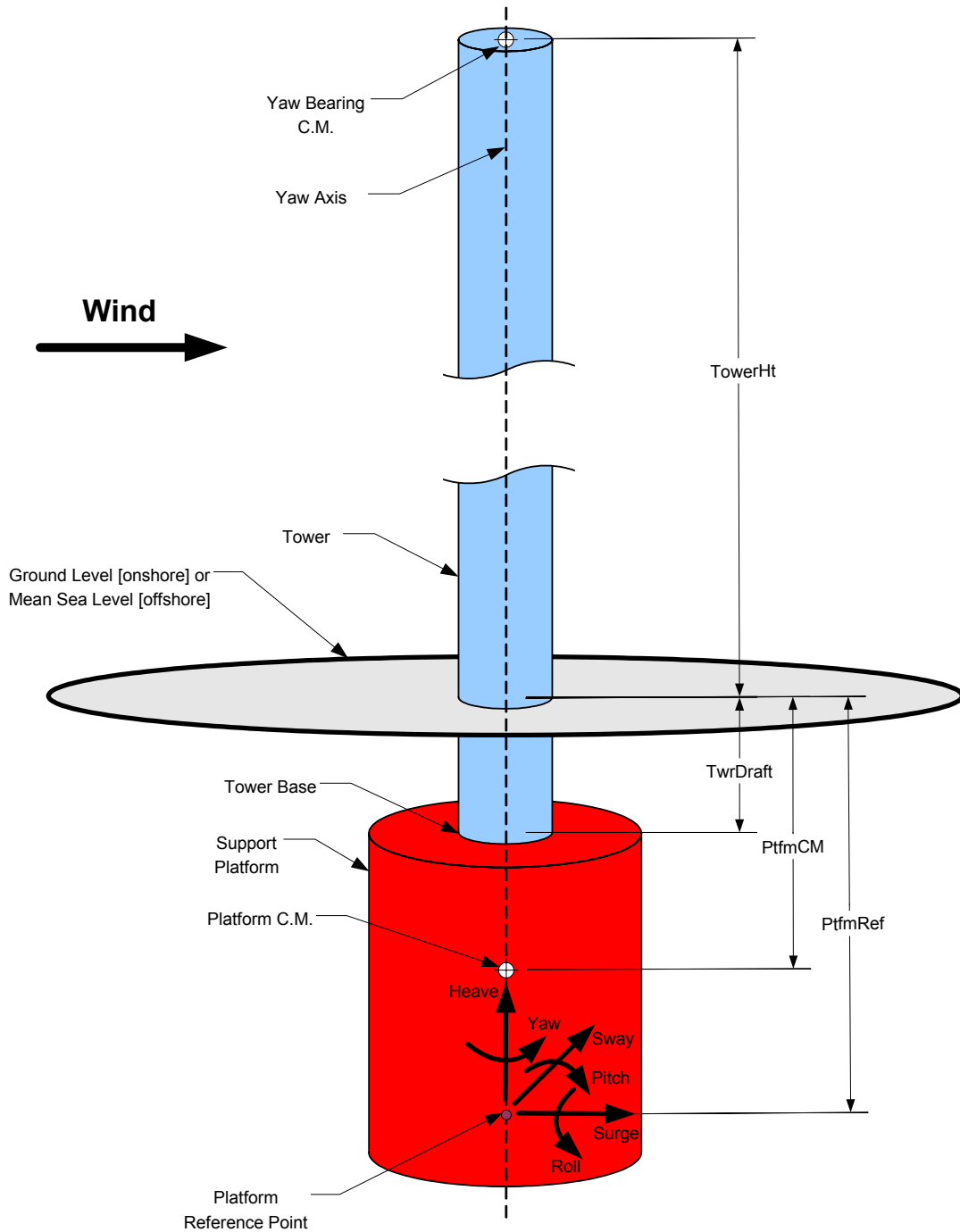

Figure 20. Support platform / foundation layout.

CONTROLS

General Description

During time-marching analyses, FAST makes it possible to control your turbine and model specific conditions in many ways. Five basic methods of control are available: pitching the blades, controlling the generator torque, applying the HSS brake, deploying the tip brakes, and yawing the nacelle. The simpler methods of controlling the turbine require nothing more than setting some of the appropriate input parameters in the Turbine Control section of the primary input file. Methods of control that are more complicated require you to either write your own routines, compile them, and link them with the rest of the program or implement your own routines in a Simulink model with which FAST can be interfaced to. For information on linking FAST with your own user-defined controllers, please see the Compiling FAST chapter. For information on interfacing FAST with Simulink, please see the Simulink Interface chapter.

To aid in wind turbine controls design and analysis, linearization routines are also included in FAST. Please reference the Linearization chapter for documentation on linearization functionality.

Blade Pitch Control

One of the most common forms of turbine control is full-span blade pitch control. To disable active pitch control, set the **PCMode** switch to 0.

Setting **PCMode** to 1 will cause FAST to call a user-written routine called `PitchCntrl()` at every time step.

A. Craig Hansen wrote a real pitch-control routine, and we supply that in the file `PitchCntrl_ACH.f90`. This routine is linked with the executable version of FAST distributed in the archive. Craig's routine controls either power (Region 2) or rotor speed (Region 3) with collective pitch control. The value of **CntrlRgn**, a parameter specified in an input file named `Pitch.ipt`, which Craig's routine calls, determines the type of control used. An example `Pitch.ipt` file is located in FAST's `CertTest` folder. The data in this file are for the WindPACT 15A1001 model. Unless you are modeling that turbine, you will need to replace his `Pitch.ipt` file with your own. Please contact Craig Hansen for additional information on this pitch controller.

Additionally, A dummy version of routine `PitchCntrl()` is available (but commented out) in source file `UserSubs.f90`. You can write your own routine here and link it with FAST, though this option requires the use of a compiler. This user-defined pitch control routine can act independently for each blade or be

rotor-collective. Within routine `PitchCntrl()` you have the ability to access the current value of **any** output parameter available from FAST without changing the number of arguments passed to the routine. Please see the dummy `PitchCntrl()` routine for a description of how to take advantage of this incredibly flexible feature.

There is no pitch actuator model built into FAST (though there is in ADAMS datasets generated by FAST); thus, you must implement your own actuator model into routine `PitchCntrl()` if you want to include actuator dynamics effects.

When using the `PitchCntrl()` routine, you can delay the time it becomes effective by setting the **TPCon** parameter to a value greater than zero and **BIPitch_i** to the initial blade pitch angles. In this case, routine `PitchCntrl()` will not be called until time **TPCon** is reached.

Setting **PCMode** to 2 causes FAST to accept pitch demands externally from Simulink. In this case, **TPCon** must be set to zero since the authority to start and stop the controller is reserved for the Simulink model. You must be using FAST as a DLL interfaced with Simulink in order to use this feature. Please see the Simulink Interface chapter for further details.

Although the input file includes a parameter for partial-span pitch (**PSPnEIN**), we have not yet implemented this feature in the code.

With or without pitch control enabled, after time **TPitManS_i**, the *i*th blade will pitch to **BIPitchF_i** using a linear ramp from its current value at **TPitManS_i** until **TPitManE_i**. If pitch control is enabled when **PCMode** is not 0, the pitch commands determined from inputs **TPitManS_i**, **TPitManE_i**, and **BIPitchF_i** override whatever commands come from the pitch controller. You can use **TPitManS_i** and **TPitManE_i** to simulate a pitch for startup, shutdown, or runaway fault pitch event. By setting one blade different from the other(s), you can simulate a fault condition in which one blade unexpectedly pitches or fails to pitch.

For a constant-pitch simulation, set **PCMode** to 0, **TPitManS_i** greater than **TMax**, and **BIPitch_i** to the fixed blade pitch angles.

The flowchart provided in Figure 21 explains how the program uses the blade pitch control input parameters during runtime, as described above. In this flowchart, **BIPitch_i** is the instantaneous blade pitch angle and **BIPitchCom_i** is the instantaneous blade pitch angle command of blade *i* (*i* = 1, 2, or 3 for blades 1, 2, or 3, respectively is implied).

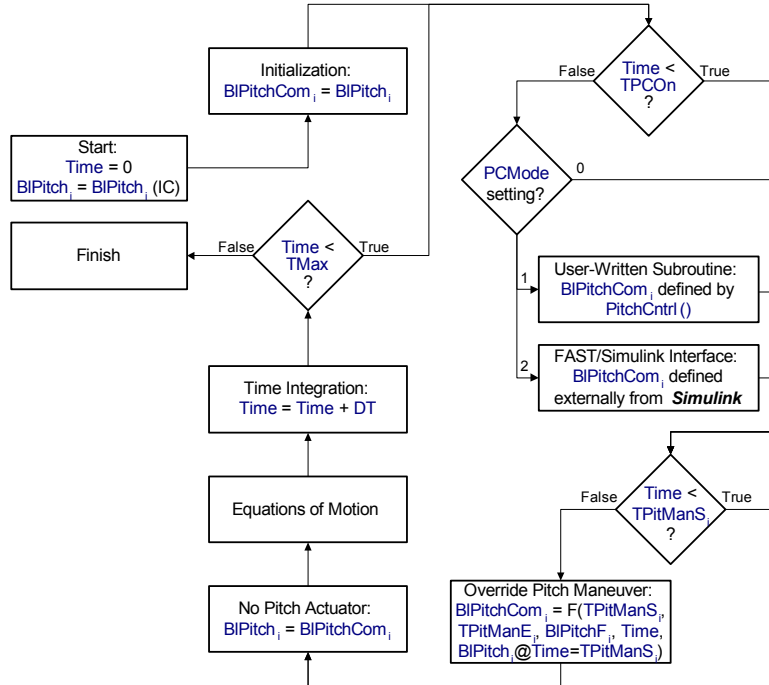

Figure 21. Flowchart of Blade Pitch Control Runtime Options.

Variable-Speed Torque Control

Variable-speed generator torque control is another common form of turbine control. To disable active torque control, set the VS_Contrl switch to 0—in this case, FAST will use one of the generator models as described in the Generator section of the Model Description chapter.

We supply a simple variable-speed control system that uses input parameters VS_RtGnSp, VS_RtTq, VS_Rgn2K, and VS_SIPc and results in the torque/speed curve seen in Figure 22. You can enable this control system by setting VSContrl to 1.

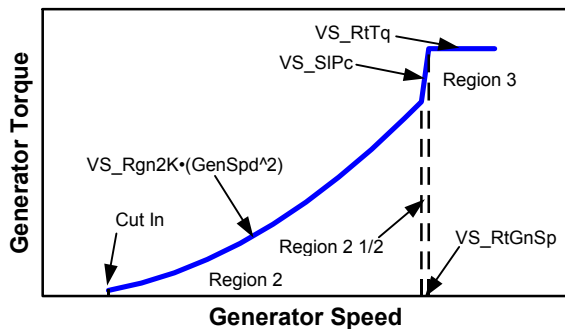

Figure 22. Torque/speed curve for simple variable-speed control.

As shown, this simple variable-speed control model distinguishes between Region 2 (maximum-power control), Region 3 (constant-torque control), and Region 2½ (linear transition). Region 2½ is a linear transition between Regions 2 and 3, with a torque slope corresponding to the slope of an equivalent induction machine. Region 2½ is commonly needed since a wind turbine does not typically reach rated torque at its rated speed using Region 2’s control law [i.e., the optimal gain VS_Rgn2K is typically lower than that which would make $VS_RtTq = VS_Rgn2K \cdot (VS_RtGnSp^2)$, since the rated speed, VS_RtGnSp, is generally limited from optimal in order to limit tip speed for noise reasons]. If you want to effectively eliminate Region 2½ from this model, set VS_RtTq = VS_Rgn2K • (VS_RtGnSp^2) and VS_SIPc = 9999.9E-9 (a very small don’t care > 0.0).

A setting of 2 for VSContrl will tell FAST to call a user-written routine named UserVSCont() at every time step after the generator is turned on. Kirk Pierce wrote an example routine when he worked at NREL and this routine, which is contained in source file *UserVSCont_KP.f90*, is linked with the executable version of FAST that is distributed in the archive. His routine uses a table lookup scheme with a built-in time delay, which reads data from a file named *Spd_Trq.dat*, an example of which is located in FAST’s *CertTest* folder. The data in this file are for the Small Wind Research Turbine (SWRT). Unless you are modeling that turbine, you will need to replace his *Spd_Trq.dat*

file with your own. Please note that Kirk Pierce's routine only works when **GBRatio** is set to 1.0.

Additionally, A dummy version of routine **UserVSCont()** is available (but commented out) in source file *UserSubs.f90*. You can write your own routine here and link it with FAST, though this option requires the use of a compiler. The routine that calls **UserVSCont()** passes the HSS speed and expects the electrical generator torque and electrical power to be returned. But within routine **UserVSCont()**, you have the ability to access the current value of **any** output parameter available from FAST without changing the number of arguments passed to the routine. Also, you have the option of switching the generator DOF on-or-off at runtime within **UserVSCont()** by overriding input **GenDOF**. Please see the supplied dummy routine in *UserSubs.f90* for further details.

Setting **VSContrl** to 3 causes FAST to accept electrical generator torque and electrical power demands externally from Simulink. In this case, the authority to start and stop the generator is reserved for the Simulink model. Thus, **GenTiStr** and **GenTiStp** must be set to True, **TimGenOn** must be set to zero, and **TimGenOf** must be set greater than **TMax**. You must be using FAST as a DLL interfaced with Simulink in order to use this feature. Please see the Simulink Interface chapter for further details.

The flowchart provided in Figure 23 explains how the program uses the variable-speed torque control input parameters during runtime, as described above. In this flowchart, **GenTq** is the instantaneous electrical generator torque, **GenPwr** is the instantaneous electrical generator power, and **GenSpeed** is the instantaneous HSS (generator) speed. The additional logic presented in the flowchart explains how the program uses the generator model and HSS brake control input parameters during runtime.

HSS Brake Control

By default, the HSS brake is disabled at the beginning of a run. At time **THSSBrDp**, the brake will start to deploy. If you do not want the brake to deploy during a given run, set **THSSBrDp** to a value greater than **TMax**.

If you set **HSSBrMode** to 1, FAST will use a simple HSS brake model in which the brake torque will ramp linearly from zero at time **THSSBrDp** to full brake torque of **HSSBrTqF** over **HSSBrDT** seconds. The HSS brake is based on the Coulomb model of

sliding friction. Once full brake torque is reached, the magnitude of the torque is constant as long as the shaft speed is nonzero. When the speed is zero, the torque takes on any value to prevent motion of the shaft (the HSS can only move again if the external torque exceeds the full braking torque).

A user-defined HSS brake model is also available. Set **HSSBrMode** to 2 to tell FAST to call the user-written routine named **UserHSSBr()** at every time step after time **THSSBrDp**. A dummy version of routine **UserHSSBr()** is available in source file *UserSubs.f90*. You can write your own routine here and link it with FAST, though this option requires the use of a compiler. The routine that calls **UserHSSBr()** passes the HSS speed and time and expects the **fraction** of full braking torque to be returned (0.0 = off – no brake torque, 1.0 = full brake torque). As in the simple HSS brake model, the magnitude of the full braking torque is specified in input **HSSBrTqF**. The fraction of full braking torque may continually vary, permitting you to continually switch the HSS brake on and off during the simulation. Input **HSSBrDT** is ignored when **HSSBrMode** is set to 2.

Within routine **UserHSSBr()**, you have the ability to access the current value of **any** output parameter available from FAST without changing the number of arguments passed to the routine. Also, you have the option of switching the generator DOF on-or-off at runtime within **UserHSSBr()** by overriding input **GenDOF**. Please see the supplied dummy routine in *UserSubs.f90* for further details.

The flowchart provided in Figure 23 explains how the program uses the HSS brake control input parameters during runtime, as described above. In this flowchart, **HSSBrFrac** is the instantaneous fraction of full braking torque [limited to values between 0.0 and 1.0 (inclusive)] and **GenSpeed** is the instantaneous HSS (generator) speed. The additional logic presented in the flowchart explains how the program uses the variable-speed and generator model control input parameters during runtime.

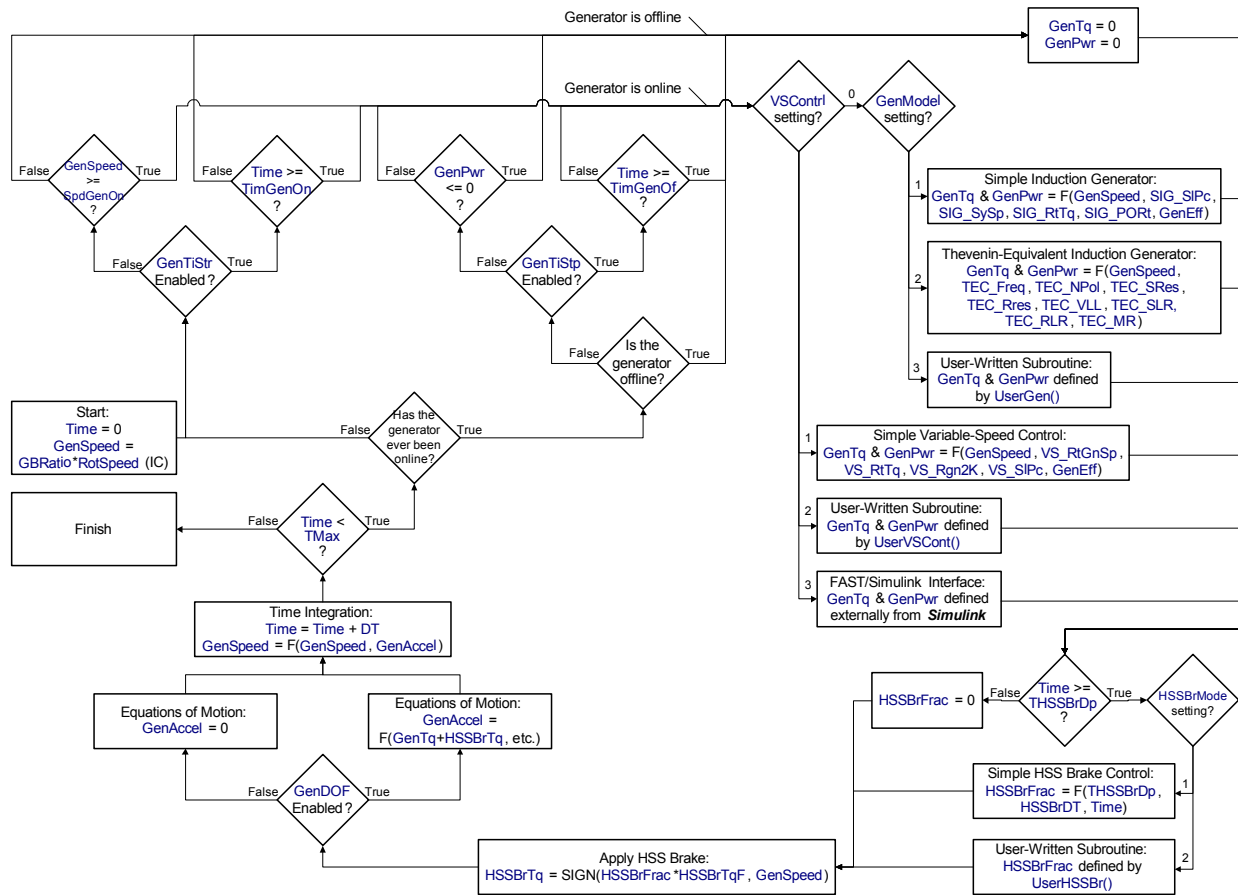

Figure 23. Flowchart of Variable-Speed, Generator, & HSS Brake Control Runtime Options.

Nacelle Yaw Control

You can actively control the nacelle-yaw motion during a simulation. To disable active yaw control, set `YCMODE` to 0.

Setting `YCMODE` to 1 will cause FAST to call a user-written routine called `UserYawCont()` at every time step. A dummy version of routine `UserYawCont()` is available in source file `UserSubs.f90`. You can write your own routine here and link it with FAST, though this option requires the use of a compiler. Though there are a few others, the most important arguments of routine `UserYawCont()` are as follows:

- `YawPos`: Current nacelle-yaw angular position in radians (input)
- `YawRate`: Current nacelle-yaw angular rate in rad/sec (input)
- `WindDir`: Current horizontal hub-height wind direction (positive about the zt-axis) in radians (input)

- `YawError`: Current nacelle-yaw error estimate (positive about the zt-axis) in radians (input)
- `ZTime`: Current simulation time in sec (input)
- `YawPosCom`: Commanded nacelle-yaw angular position (demand yaw angle) in radians (output)
- `YawRateCom`: Commanded nacelle-yaw angular rate (demand yaw rate) in rad/sec (output)

As indicated, the yaw controller must always specify a command (demand) yaw angle, `YawPosCom`, and command (demand) yaw rate, `YawRateCom`. Normally, you should correlate these commands so that the commanded yaw angle is the integral of the commanded yaw rate, or likewise, the commanded yaw rate is the derivative of the commanded yaw angle. FAST **will not** compute these correlations for you and **does not** check to ensure that they are correlated. In some situations, it is desirable to set one of the commands (either yaw angle or yaw rate) to **zero** depending on the desired transfer function of FAST's built-in actuator model (see below for a

discussion of FAST's built-in actuator model). In general, the commanded yaw angle and rate **should never** be defined independent of each other with **both** commands **nonzero**.

Setting `YCMODE` to 2 causes FAST to accept demand yaw angles and rates externally from Simulink. You must be using FAST as a DLL interfaced with Simulink in order to use this feature. Please see the Simulink Interface chapter for further details.

The yaw controller's effect on the FAST model depends on whether or not the yaw DOF is enabled. If the yaw DOF is disabled (`YawDOF = False`), then the commanded yaw angle and rate from routine `UserYawCont()` or Simulink will be the **actual** yaw angle and yaw rate used internally by FAST (in general, you should ensure these are correlated). In this case, any desired actuator effects should be built within the yaw control routine. Also in this case, FAST **will not** compute the correlated yaw acceleration, but assume that it is **zero**. If the commanded yaw rate is zero while the commanded yaw angle is changing in time, then the yaw controller's effect on yaw angle is the identical to routine `PitchCntrl()`'s effect on pitch angle (i.e., routine `PitchCntrl()` commands changes in pitch angle with no associated changes in pitch rate or pitch acceleration). For yaw control, this situation should be avoided however, since yaw-induced gyroscopic pitching loads on the turbine brought about by the yaw rate may be significant.

If the nacelle yaw DOF is enabled (`YawDOF = True`), then the commanded yaw angle and rate from routine `UserYawCont()` or Simulink become the neutral yaw angle, `YawNeut`, and neutral yaw rate, `YawRateNeut`, in FAST's built-in second-order actuator model defined by inputs `YawSpr` and `YawDamp`. In the time domain, the equation for the yaw DOF is then:

$$\begin{aligned} & \text{YawIner} \cdot \text{YawAccel} + \text{YawDamp} \cdot \text{YawRate} + \\ & \text{YawSpr} \cdot \text{YawPos} = \\ & \text{YawDamp} \cdot \text{YawRateNeut} + \\ & \text{YawSpr} \cdot \text{YawNeut} + \text{YawTq} \end{aligned}$$

where `YawIner` is the instantaneous inertia of the nacelle, rotor, and tail about the yaw axis and `YawTq` is the torque about the yaw axis applied by external forces above the yaw bearing, such as wind loading. Thus, the torque transmitted through the yaw bearing, `YawMom`, is:

$$\begin{aligned} \text{YawMom} = & \text{YawSpr} \cdot (\text{YawPos} - \text{YawNeut}) + \\ & \text{YawDamp} \cdot (\text{YawRate} - \text{YawRateNeut}) \end{aligned}$$

If the commanded yaw angle and rate are correlated (so that the commanded yaw angle is the integral of the commanded yaw rate, or likewise, the commanded yaw rate is the derivative of the

commanded yaw angle), then FAST's built-in second-order actuator model will have the following characteristic transfer function, $T(s)$:

$$\begin{aligned} T(s) &= \frac{\text{YawDamp} \cdot s + \text{YawSpr}}{\text{YawIner} \cdot s^2 + \text{YawDamp} \cdot s + \text{YawSpr}} \\ &= \frac{2 \cdot \zeta \cdot \omega_n \cdot s + \omega_n^2}{s^2 + 2 \cdot \zeta \cdot \omega_n \cdot s + \omega_n^2} \end{aligned}$$

where $\omega_n = \text{SQRT}(\text{YawSpr}/\text{YawIner})$ is the yaw actuator natural frequency in rad/sec and $\zeta = \text{YawDamp} / (2 \cdot \text{SQRT}(\text{YawSpr} \cdot \text{YawIner}))$ is the yaw actuator damping ratio in fraction of critical.

If only the yaw angle is commanded, and `YawRateCom` is zeroed, then the characteristic transfer function of FAST's built-in second-order actuator model simplifies to:

$$\begin{aligned} T(s) &= \frac{\text{YawSpr}}{\text{YawIner} \cdot s^2 + \text{YawDamp} \cdot s + \text{YawSpr}} \\ &= \frac{\omega_n^2}{s^2 + 2 \cdot \zeta \cdot \omega_n \cdot s + \omega_n^2} \end{aligned}$$

If only the yaw rate is commanded, and `YawPosCom` is zeroed, then the characteristic transfer function of FAST's built-in second-order actuator model simplifies to:

$$\begin{aligned} T(s) &= \frac{\text{YawDamp}}{\text{YawIner} \cdot s^2 + \text{YawDamp} \cdot s + \text{YawSpr}} \\ &= \frac{2 \cdot \zeta \cdot \omega_n}{s^2 + 2 \cdot \zeta \cdot \omega_n \cdot s + \omega_n^2} \end{aligned}$$

Within routine `UserYawCont()` you have the option of switching the nacelle-yaw DOF on-or-off at runtime by overriding input `YawDOF`. You can also access the current value of **any** output parameter available from FAST without changing the number of arguments passed to the routine. Please see the dummy `UserYawCont()` routine for a description of how to take advantage of these incredibly flexible features.

When using the `UserYawCont()` routine, you can delay the time it becomes effective by setting the `TYCON` parameter to a value greater than zero and `NacYaw` and `YawNeut` to the initial nacelle yaw angle and neutral yaw position, respectively (the neutral yaw rate, `YawRateNeut`, is always assumed zero until active yaw control is enabled). In this case, routine `UserYawCont()` will not be called until time `TYCON` is reached. `TYCON` must be set to zero when controlling yaw from Simulink, when `YCMODE` is set to 2, since the authority to start and stop the yaw controller is reserved for Simulink.

With or without yaw control or the yaw DOF enabled, after time `TYawManS`, the nacelle will yaw to `NacYawF` using a linear ramp from its current value at `TYawManS` until `TYawManE`. If yaw control is enabled when `YCMODE` is not 0, the yaw commands determined from inputs `TYawManS`, `TYawManE`, and `NacYawF` override whatever commands come

from the yaw controller. Also, the yaw commands determined from inputs `TYawManS`, `TYawManE`, and `NacYawF` pass through FAST's built-in second-order actuator model if the yaw DOF is enabled when `YawDOF` is set to `True`. You can use `TYawManS` and `TYawManE` to simulate a yaw for startup, shutdown, or runaway yaw event.

For a fixed-yaw simulation, set `YawDOF` to `False`, `YCMODE` to 0, `TYawManS` greater than `TMax`, and `NacYaw` to the fixed nacelle yaw angle.

You can also enable passive nacelle-yaw control during a simulation. Please see the Nacelle Yaw section in the Model Description chapter for information on passive yaw control options.

The flowchart provided in Figure 24 explains how the program uses the nacelle yaw control input parameters during runtime, as described above.

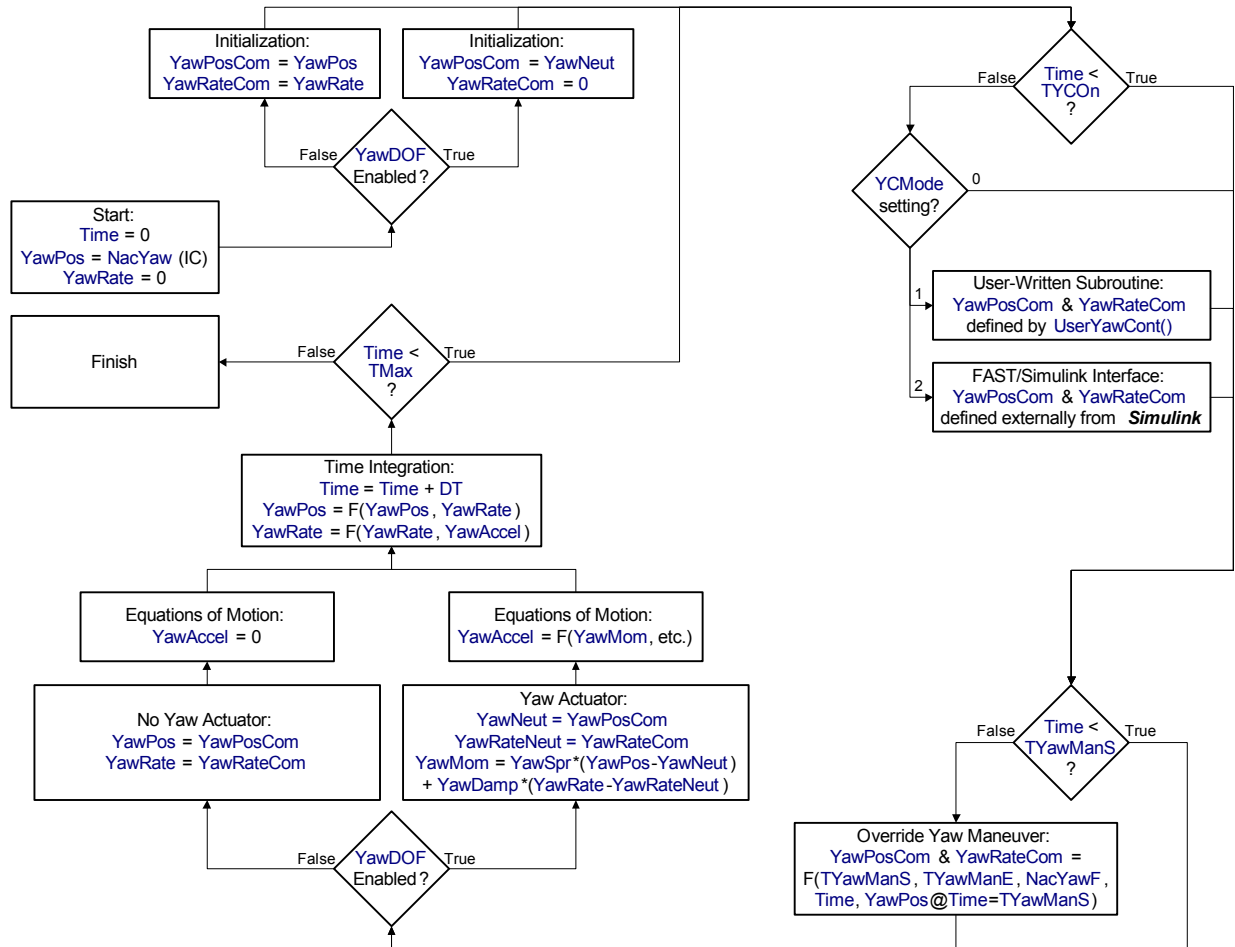

Figure 24. Flowchart of Nacelle Yaw Control Runtime Options.

Master Controllers and the Bladed-Style DLL Interface

In the *Source* folder of the FAST archive, we distribute a source file named *BladedDLLInterface.f90*. This source file contains example `PitchCntrl()`, `UserHSSBr()`, `UserVSCont()`, and `UserYawCont()` routines that may be used to interface FAST with a master controller implemented as a dynamic-link-library (DLL) in the style of Garrad Hassan's Bladed

wind turbine software package. All four routines call routine `BladedDLLInterface()`, which contains a call to the Bladed-style DLL that evaluates as `DISCON()`. See Figure 25 for a schematic. Routine `BladedDLLInterface()` uses a `MODULE` named `BladedDLLParameters()`, which stores values of `PARAMETER` constants used in the interface. Routines `BladedDLLInterface()` and `BladedDLLParameters()` are also contained in source file *BladedDLLInterface.f90*.

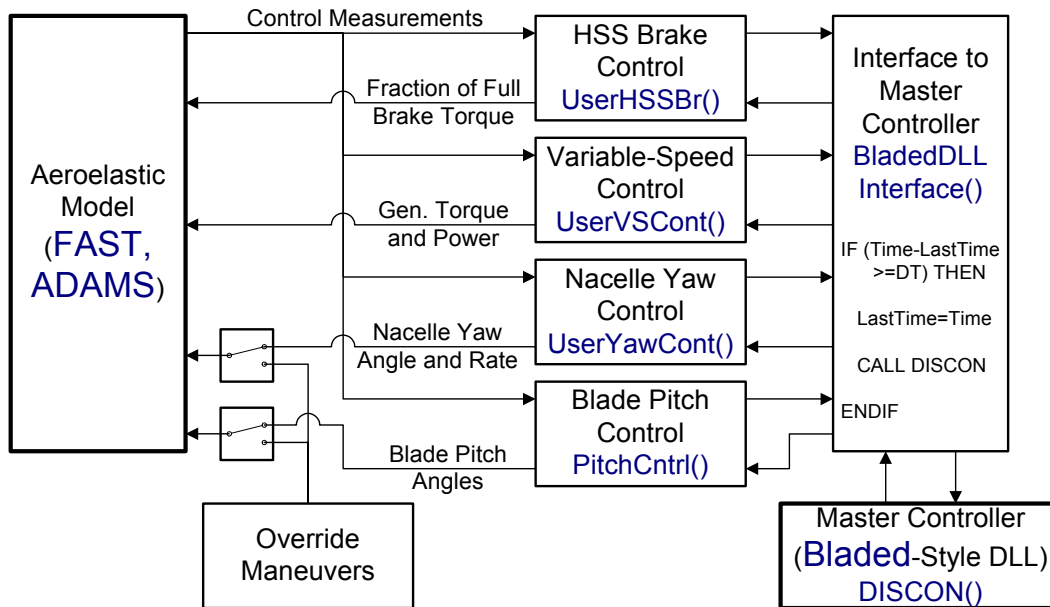

Figure 25. Interface to a Bladed-Style Master Controller DLL.

Source file *BladedDLLInterface.f90* is useful if you have a DLL controller created for a Bladed model and you want to use the same controller for your FAST model. This source file is also a useful template if you prefer to control pitch, HSS brake torque, electrical generator torque, and/or nacelle yaw with a single master controller, regardless of whether or not you use the Bladed code and regardless of whether or not you want to work with DLLs. As it is developed, the same source file can be used to interface both FAST and ADAMS to Bladed-style master controller DLLs.

In order to use these routines, you must first set the values of the PARAMETERS contained in MODULE *BladedDLLParameters()* as required by your model. These PARAMETERS are model-specific inputs available in the Bladed code, which are not available inputs in FAST, and are passed to the Bladed DLL in this interface. You must then comment-out the dummy placeholder versions of routines *PitchCntrl()*, *UserHSSBr()*, *UserVSCont()*, and *UserYawCont()* contained in source file *UserSubs.f90* and recompile FAST with the addition of source file *BladedDLLInterface.f90*—see the Compiling FAST chapter for more information. The executable version of FAST that is distributed with the archive is **not** linked with the routines contained within source file *BladedDLLInterface.f90*. After you have compiled FAST with the routines in *BladedDLLInterface.f90*, you must modify several input parameters from the primary input file in order to use the Bladed-style controller. These parameters and the necessary settings are listed in Table 3 (these conditions are **not** tested by these example routines).

This interface is valid for DLLs of the style specified in Appendices A and B of the Bladed User Manual of Bladed version 3.6 (2). The documentation provided there is not repeated here. If you are running FAST using a master controller DLL developed in Bladed, please be aware of the differences indicated in Table 4 between this interface and Bladed's interface.

Table 3. Parameter Settings to be Used With Bladed-Style Master Controller DLLs.

Parameter	Setting	Reason
YCMODE	1	Tells FAST to use routine <i>UserYawCont()</i> for active yaw control
TYCON	0.0	Tells FAST to start active yaw control at the beginning of the simulation
PCMODE	1	Tells FAST to use routine <i>PitchCntrl()</i> for active pitch control
TPCON	0.0	Tells FAST to start active pitch control at the beginning of the simulation
VSCONTR	2	Tells FAST to use routine <i>UserVSCont()</i> for active variable-speed torque control
GenTiStr	True	Tells FAST to start torque control based on time <i>TimGenOn</i>
GenTiStp	True	Tells FAST to stop torque control based on time <i>TimGenOf</i>

TimGenOn	0.0	Tells FAST to start torque control at the beginning of the simulation
TimGenOf	>TMax	Tells FAST not to stop controlling torque throughout the simulation
HSSBrMode	2	Tells FAST to use routine UserHSSBr() for control of the HSS brake
THSSBrDp	0.0	Tells FAST to start HSS brake torque control at the beginning of the simulation

Table 4. Differences Between FAST's and Bladed's Interface to Master Controller DLLs.

Record	Difference
1	The status flag is not set to -1 for the final call at the end of the simulation
10	The pitch actuator type is always set to 0 by FAST, indicating pitch position actuator; as such, the returned value of Record 46, demanded pitch rate (Collective pitch), is always ignored
29	The yaw control type is always set to 0 by FAST indicating yaw rate control; as such, the returned value of Record 41, demanded yaw actuator torque, is always ignored
35	The generator contactor status, is initialized to 1 by FAST indicating main (high speed) or variable speed generator; the generator can be turned off in the DLL by setting Record 35 to 0 or by setting Record 47 to 0.0; if the DLL redefines Record 35 to something other than 0 or 1 (such as 2 = low speed generator), the program will abort
41	The demanded yaw actuator torque is always ignored in accordance with the specification of Record 29
46	The demanded pitch rate (Collective pitch) is always ignored in accordance with the specification of Record 10
55	The pitch override returned by the DLL must be set to 0 indicating no override (i.e., pitch demands come for the DLL); the program will abort otherwise
56	The torque override returned by the DLL must be set to indicating no override (i.e., torque demands come for the DLL); the program will abort otherwise
62	The maximum number of values which can be returned for logging is always set to 0 by FAST indicating none
63	The record number for start of logging output is always set to 0 (a don't care) by FAST in accordance with the specification

	of Record 62
64	The maximum number of characters which can be returned in "OUTNAME" is always set to 0 in accordance with the specification of Record 62
65	The number of variables returned for logging returned by the DLL must be set to 0 by the DLL indicating none in accordance with the specification of Record 62; the program will abort otherwise
72	The generator start-up resistance is always ignored
79	The request for loads is ignored; instead, the blade, hub, and yaw bearing loads are always passed to the DLL as if Record 79 was set to 4
80	The variable-slip current demand toggle switch is always ignored; instead, the generator torque demand from Record 47 is always used
81	The variable-slip current demand is always ignored in accordance with the handling of Record 80

We distribute a dummy placeholder version of the source file *DISCON.f90* in the FAST archive. You may use *DISCON.f90* as a template for creating your own master controller DLL if you do not already have one created. Please refer to appendices A and B of the Bladed User Manual for further information.

Tip Brakes

The tip brakes can be controlled in two ways. You can set a time at which each brake is deployed (TTpBrDp_i), or you can set a rotor speed at which each brake is deployed (TBDeplSp_i). The tip brakes for different blades are controlled separately. If your turbine does not have tip brakes, set the tip-brake drag terms, TBDrConN and TBDrConD, to zero. You should also set the deployment times and speeds to values greater than those that are likely to occur during the run so that FAST won't waste time on unused calculations.

If you do use tip brakes, you will need to provide realistic values for the drag terms and the amount of time it takes to deploy them once they've started to deploy (TpBrDT). The brakes take this long to deploy for time- and speed-initiated deployments. Once the brakes deploy, they remain so until the end of the run. The interpolated drag term during the deployment follows an "S" curve from TBDrConN to TBDrConD.

FAST does not orient the tip-brake forces with blade pitch. The tangential velocity of the blade tip, not taking into account wind motion, is used to calculate the dynamic pressure. Because of these

approximations, you should adjust `TBDrConD` so that the rotor decelerates as expected.

Simulating Special Events

There are many special events that can be modeled with FAST. Although we will illustrate many of them in this section, we cannot document all of them. We hope that these examples will be sufficient so that you can figure out how to model other cases.

Turbine Startup

There are several ways to start a turbine. One common way is to pitch the blades from feather to the run position and let the wind accelerate the rotor until a certain speed is reached. To model this case, set `PCMode` to 0, `GenTiStr` to False, and `SpdGenOn` to an appropriate value. For each blade, set `TPitManS` to the time you want to start the maneuver, `TPitManE` to the end time for the maneuver, `BIPitch` to the feather position, and `BIPitchF` to the run position.

You can also start a stall-regulated turbine by motoring. To perform a motor start, set `PCMode` to 0, `GenTiStr` to True, and `TimGenOn` to an appropriate value. You should also use either variable-speed control or the Thevenin-equivalent-induction-generator model. Do not use the simple-induction-generator model, because it does not have a realistic startup torque.

Normal Pitch-to-Feather Shutdown

To simulate this case, you'll need to set the pitch maneuver start and stop times (`TPitManS` and `TPitManE`) and the initial and final pitch settings (`BIPitch` and `BIPitchF`). Set `TiGenOn` to zero and, if you want to use the generator as a brake, set `GenTiStp` to False. This will disengage the generator when the turbine slows enough to drop the power to zero.

Shutdown Where One Blade Fails to Feather

This case is the same as the previous example, but either set the times (`TPitManS` and `TPitManE`) for one blade to values greater than `TMax` or set the final pitch value, `BIPitchF`, to the initial pitch value (`BIPitch`) or some other value that is different from the other blade(s).

One Blade Feathers Accidentally

This case is the same as the previous example, but either set the times (`TPitManS` and `TPitManE`) for the non-feathering blade(s) to values greater than `TMax`, or set the final pitch value(s), `BIPitchF`, to the initial pitch value(s) (`BIPitch`).

HSS Brake Shutdown after Loss of Grid

To model an emergency shutdown where the HSS brake stops the rotor, set `GenTiStp` to True and `TimGenOf` to the time you want the grid to fail. When using the simple built-in HSS brake model

(`HSSBrMode` = 1), set `THSSBrDp` to a short time after `TimGenOf` and `HSSBrDt` to the amount of time it takes to fully apply the brake (the brake torque will ramp from zero to full in a linear fashion). When using a user-defined HSS brake model (`HSSBrMode` = 2), you may specify a nonlinear ramp. Input `HSSBrTqF` specifies the maximum full brake torque in both cases.

HSS Brake Shutdown with Generator Brake

FAST can model a shutdown in which the generator acts as a dynamic brake until the rotor slows enough that the HSS brake can stop the rotor, but for now you must write the logic yourself by supplying a `UserGen()` routine and linking it with the rest of the code. We hope to find an easier way by adding a few input parameters.

Normal Tip Brake Shutdown

To model a normal shutdown, in which the tip brakes decelerate the rotor, set `TTpBrDp` to appropriate values for each blade. As with the pitch-to-feather shutdown, set `GenTiStp` to False so that the generator will disengage when power drops to zero.

Tip Brake Shutdown after Loss of Grid

This case is similar to the previous case, but you'll use the `TBDepISp` array to make FAST use rotor speed to deploy the tip brakes. You can also model the special case in which one brake deploys at a higher speed than the other(s) or not at all by setting its deployment initiation speed to a higher speed.

Accidental Deployment of a Tip Brake

You can easily model the accidental deployment of a tip brake. For one blade, set `TTpBrDp` to a value less than `TMax`. For the other blade(s), set `TTpBrDp` to value(s) greater than `TMax`. For all blades, set `TBDepISp` to large numbers so that the brakes will never deploy because of rotor speed. You will also need to set `TBDrConN`, `TBDrConD`, and `TpBrDT` to appropriate values.

Idling Turbine

You can simulate an idling turbine by enabling the generator DOF (`GenDOF`) and setting `GenTiStr` to True and `TimGenOn` to a value greater than `TMax` to ensure that the generator never goes online. You will also want to initialize the rotor speed (`RotSpeed`) to a small or zero value, set the generator inertia (`GenIner`) to a non-zero value, and set the gearbox efficiency (`GboxEff`) to a value less than 100%. The torque passing through the non-perfect gearbox to the generator-rotor inertia will tend to resist acceleration of the turbine rotor. You can also add some speed-independent drag to the drivetrain by applying a light brake load. To do so, tell the brake to always be on by setting `THSSBrDp` and `HSSBrDt` to 0, and then set the brake torque (`HSSBrTqF`) to a small value.

Parked Turbine

One of the standard IEC test cases is to model the turbine in high winds when the turbine is parked. If your turbine uses full-span pitch, set the values of `BIPitch` and `BIPitchF` to the feathered setting. Also set `TpitManS` and `TpitManE` to 0 so the blades are feathered during the entire simulation.

If you park your turbine by applying a HSS brake, you can model this condition by disabling the generator DOF (`GenDOF`) with `RotSpeed` set to zero and enabling the drivetrain DOF (`DrTrDOF`) to allow the

drivetrain to ring. Another possibility is to enable `GenDOF`, but set `GenTiStr` and `TimGenOn` so the generator never starts. Set `THSSBrDp` and `HSSBrDT` to zero so the HSS brake is always on. You will need to set the `HSSBrTqF` to a realistic value.

For potential failure modes, you can model the case in which the brake torque is insufficient to hold the turbine. The generator DOF must be enabled for this case. You can examine another potential failure by setting one of the blades so that it pitches to a non-feathered value at some time during the run.

SIMULINK INTERFACE

General Description

Simulink is a popular simulation tool for controls design that is distributed by The Mathworks, Inc. in conjunction with MATLAB. Simulink has the ability to incorporate custom Fortran routines in a **block** called an **S-Function**. The FAST subroutines have been linked with a MATLAB standard gateway subroutine in order to use the FAST equations of motion in an S-Function that can be incorporated in a Simulink model. This introduces tremendous flexibility in wind turbine controls implementation during simulation. Generator torque control, nacelle yaw control, and pitch control modules can be designed in the Simulink environment and simulated while making use of the complete nonlinear aeroelastic wind turbine equations of motion available in FAST.

The wind turbine block, as shown in Figure 26, contains the S-Function block with the FAST equations of motion. It also contains blocks that integrate the DOF accelerations to get velocities and displacements. Thus the equations of motion are formulated in the FAST S-function but solved using one of the Simulink solvers.

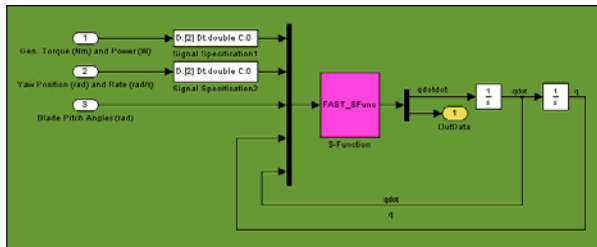

Figure 26. FAST Wind Turbine Block.

The interface between FAST and Simulink is very similar to the interface developed for the Symbolic Dynamics (SymDyn) code, which is a controls-oriented HAWT analysis tool developed by researchers at NREL (11). The structural model of FAST, however, is of higher fidelity than that of SymDyn.

Getting Started

In order to build a Simulink model that uses the FAST wind turbine dynamics in an S-Function, you must purchase the commercial MATLAB software with the additional Simulink package. MATLAB is available from The Mathworks, Inc.

(<http://www.mathworks.com/>). A working knowledge of Simulink model development is also essential.

The FAST archive contains several files that are pertinent to FAST's interface with Simulink as described below:

FAST_SFunc.dll The FAST S-Function compiled as a dynamic-link-library (DLL). This DLL contains the structural dynamic routines from FAST, the aerodynamic routines from AeroDyn, and interfaces to Simulink.

Simsetup.m This MATLAB script file prompts the user for the FAST primary input file name and calls *Read_FAST_Input.m*, which initializes model variables. It must be called from the MATLAB workspace before you run a Simulink model with the FAST S-Function.

Read_FAST_Input.m This MATLAB script file is called by *Simsetup.m* and reads the FAST input files to initialize parameters in a Simulink model. Users should **not** change this file.

OpenLoop.mdl An example Simulink model containing the FAST S-Function block, blocks that integrate the DOFs, and **constant** open loop control input blocks.

Test01_SIG.mdl An example Simulink model containing the FAST S-Function block, blocks that integrate the DOFs, and the simple induction generator model for FAST certification test #01 implemented within Simulink.

To run a FAST model in Simulink, first transfer files *Simsetup.m* and *OpenLoop.mdl* from the *SimulinkSamples* folder to the directory containing the primary input file of a FAST model that you want to use. If you want to use one of the certification test files from the *CertTest* folder, you may have to make a few minor changes to some of the input parameters in order to use the FAST S-Function in Simulink (refer to the next section for the reason).

Now open a MATLAB command window. In MATLAB, add the folder where files *FAST_SFunc.dll* and *Read_FAST_Input.m* are stored to the MATLAB path by choosing “Set Path...” from the File menu, clicking “Add Folder...”, selecting the folder, and pressing Save and Close. Next, change the current working directory in MATLAB to the directory in which the FAST model files (including files *Simsetup.m* and *OpenLoop.mdl*) are stored. Type “Simsetup” into the MATLAB command prompt. The script file will prompt you for the name of the primary input file of FAST; type in the root name with extension. Next, open the example Simulink model, *OpenLoop.mdl*, by choosing Open... from the File menu. The Simulink model should appear as in Figure 27 below (the green block in Figure 27 contains the FAST wind turbine block shown in Figure 26). Finally, click on the Play (▶) button in the Simulink window to run the simulation.

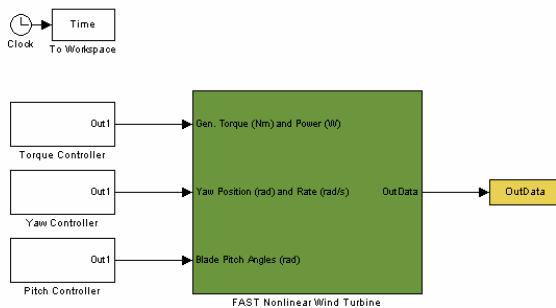

Figure 27. Simulink Model *OpenLoop.mdl*.

The FAST S-Function will generate the same ASCII output files as would be generated during a normal FAST simulation. These output files use the root name of the primary input file and append *_SFunc* to the name. For example, if the primary input file were named *fast.fst*, the main output file from the FAST S-Function will be named *fast_SFunc.out* whereas the the FAST executable would generate *fast.out*. The output for the certification test files should agree quite well with the corresponding output from FAST. There will be slight differences due to the different solvers and precisions employed by each program.

If for any reason an error occurs during a simulation, the FAST S-Function will display the error message in a Simulation Diagnostics pop-up box and abort. Warning messages routinely written to the command-line window by the FAST executable are not echoed to a pop-up box nor are they echoed to the MATLAB workspace by the FAST S-Function. We hope to add this capability in the future.

Specific Input File Options for the FAST S-Function

As implied above, FAST input files must be created in order to use the FAST S-Function. Some input parameters directly control the execution of the Simulink model; others cause the FAST S-Function to abort; most behave exactly as they do in the executable version of FAST.

FAST input variables *TMax* and *DT* may be used to control the Simulink simulation by entering them in the Stop time and Fixed step size boxes, which are contained in the “Simulation parameters...” window available from the Simulation menu of the Simulink model. These are only available if a fixed step solver is selected. The fixed step solver, *ode4*, most closely emulates the solver used by FAST. These settings have already been specified in *OpenLoop.mdl* but may be changed by you depending on your preference.

Under the Turbine Control section of FAST’s primary input file, you have the option of determining whether blade pitch, nacelle yaw, and/or variable-speed torque is controlled by the Simulink model or by using one of FAST’s intrinsic controllers. To control blade pitch commands from Simulink, set *PCMode* to 2. In this case, *TPCon* must be set to zero since the authority to start and stop the controller is reserved for the Simulink model. If *PCMode* is either 0 or 1, the model will behave exactly as a standalone FAST model and the pitch commands from Simulink will be ignored. Similarly, to control nacelle yaw angle and rate commands from Simulink, set *YCMODE* to 2. In this case, *TYCON* must be set to zero since the authority to start and stop the controller is reserved for the Simulink model. To model a variable-speed torque controller in Simulink, *VSContrl* must be set to 3. In this case, the authority to start and stop the generator is reserved for the Simulink model. Thus, *GenTiStr* and *GenTiStp* must be set to True, *TimGenOn* must be set to zero, and *TimGenOf* must be set greater than *TMax*.

The override pitch and yaw maneuvers specified in FAST’s primary input file will supercede any pitch and yaw commands that originate in Simulink regardless of the setting of *PCMode* and *YCMODE*. You may use these to force faults in you pitch and yaw controllers.

Some features of FAST are not available within Simulink. Thus, when running FAST within Simulink, the FAST S-Function will abort if any of these features are selected. The ADAMS preprocessor and the linearization capability are not available in the FAST S-Function; thus, *ADAMSPrep* and *AnalMode* must be set to 1. The high-speed shaft brake option is not available in the FAST S-Function so *THSSBrDp* must be set greater than *TMax*. Finally, Simulink can only use the initial conditions for revolute DOFs, including *Azimuth*, *RotSpeed*, *TeetDefl*, *NacYaw*, *RotFurl*, and *TailFurl*. Specifying nonzero values for *IPDefl*,

Customizing the Simulink Model

This section provides a few more details on the FAST interface to Simulink. This should provide you with enough guidance so that you can modify the example Simulink models to include your own torque, yaw, and/or pitch controllers.

The wind turbine block requires three inputs and has one output as shown in Figure 26 and Figure 27. Electrical generator torque and electric power demands must be supplied in the first input, nacelle yaw position and rate demands must be supplied in the second input, and blade pitch demand angles for all blades must be supplied in the third input. Data must be provided for **all** inputs in order for the Simulink model to run. For instance, if you want to use the FAST simple induction generator model (by setting `VSContrl` to 0 and `GenModel` to 1) rather than developing a torque controller in your Simulink model, you may use Constant blocks to supply **dummy** electrical generator torque and electrical power demands to the FAST wind turbine block—these will **not** be used by the wind turbine block, but they **must** be present. This is demonstrated in *OpenLoop.mdl*. Similarly, values must be supplied for the yaw position and rate, and the blade pitch angles. The blade pitch angles are stored in a vector sized according to the number of blades.

In addition to the data available in the primary output file generated by the S-Function, the wind turbine block will also output a variable array named `OutData` that contains the output data selected in the FAST input file through input `OutList`. `OutData` contains output data at **every** model time step (whereas the primary output file uses the value of `DecFact`) and is available in the Simulink environment at runtime for feeding back control measurements. Thus, the control measurement channels your Simulink controller needs must be specified in `OutList`. `OutData` will also be available in the MATLAB workspace for postprocessing.

The output data names listed in `OutList` are also available in MATLAB and Simulink workspaces in a variable cell array named, appropriately, `OutList`. This variable is created by the *Read_FAST_Input.m* script

file. You can access specific channels from the `OutData` array by using the `OutList` cell array. For example, to obtain the rotor speed (assuming rotor speed was specified in `OutList`) at the 3rd time step (3rd row) in the MATLAB workspace, type `“OutData(3,strcmp(‘RotSpeed’,OutList))”` in the MATLAB command prompt. Using this technique, you don’t need to remember the specific order you listed the output channel names in `OutList`.

You can modify the *Simsetup.m* script file to initialize variables for any additions you make to the Simulink model for torque, yaw, and pitch control. If you modify *Simsetup.m*, remember to use “clear all” or “clear functions” to clear the MATLAB memory before repeating a simulation. As provided, “clear all” is the first command in *Simsetup.m*. The character array named `input_fast`, which is defined in *Simsetup.m*, must contain the name of the primary input file. Also, the script that reads the FAST input file for model initialization, *Read_FAST_Input.m*, must be called before running a simulation and after `input_fast` has been defined. Other than these requirements, you are free to perform any controller design or initialization steps in *Simsetup.m* or your own script before performing a simulation in Simulink.

As an example of a Simulink model more advanced than *OpenLoop.mdl*, we distribute a Simulink model named *Test01_SIG.mdl* in the FAST archive. In this example, the simple induction generator (available when `VSContrl` is set to 0 and `GenModel` is set to 1) is implemented in Simulink rather than FAST for certification test #01 (by setting `VSContrl` to 2). To run this example, follow the directions in the comments at the end of *Simsetup.m*. The output should be **very** similar to that of certification test #01 run with the FAST executable. There will be slight differences due to the different solvers and precisions employed by each program.

LINEARIZATION

General Description

FAST has the capability of extracting linearized representations of the complete nonlinear aeroelastic wind turbine modeled in the code. This analysis capability is useful for developing state matrices of a wind turbine “plant” to aid in controls design and analysis. It is also useful for determining the full system modes of an operating or stationary HAWT through the use of a simple eigenanalysis. A FAST linearization analysis is invoked by setting input parameter `AnalMode` in the primary input file to 2.

The linearization routines follow a procedure similar to that used by the Symbolic Dynamics (SymDyn) code, which is a controls-oriented HAWT analysis tool developed by researchers at NREL (11). The structural model of FAST, however, is of higher fidelity than that of SymDyn.

The linearization process consists of two steps: (1) computing a periodic steady state operating point condition for the DOFs and (2) numerically linearizing the FAST model about this operating point to form periodic state matrices. The output state matrices can then be azimuth-averaged for nonperiodic, or time-invariant controls development.

Periodic Steady State Solution

The first step in the linearization process is determining an operating point to linearize the model about. An operating point is a set of values of the system DOF displacements, DOF velocities, DOF accelerations, control inputs, and wind inputs that characterize a steady condition of the wind turbine. For a wind turbine operating in steady winds, this operating point is periodic—that is, the operating point values depend on the rotor azimuth orientation. This periodicity is driven by aerodynamic loads, which depend on the rotor azimuth position in the presence of prescribed shaft tilt, wind shear, yaw error, or tower shadow. Gravitational loads also drive the periodic behavior when there is a prescribed shaft tilt or appreciable deflection of the tower due to thrust loading. It is important to determine an accurate operating point because the linearized model is only accurate for values of the DOFs and inputs that are close to the operating point values.

To compute a steady state solution, the program inputs must necessarily produce a time invariant model (other than azimuth dependence). To insure this time invariant condition, FAST performs a number of checks on some of the input parameters before running a linearization analysis. FAST will abort without computing the linearized state matrices if any of the

following conditions are not met. First, active yaw and pitch control must be disabled by setting `YCMode` and `PCMode` to 0. FAST can't be linearized during a startup or shutdown event, thus `GenTiStr` and `GenTiStp` must both be set True, `TimGenOn` must be set to 0.0, and `TimGenOf` must be set greater than `TMax` during a linearization analysis. Inputs `THSSBrDp`, `TiDynBrk`, `TTpBrDpi`, `TYawManS`, and `TPitManSi` must also be set greater than `TMax`, and `TBDepISpi` must be set much greater than `RotSpeed`. In AeroDyn, dynamic stall and dynamic inflow must be disabled if `CompAero` is True; thus `StallMod` should be set to “STEADY” and `InfModel` to “EQUIL”ibrium. Also, you must use a hub-height wind data file (input `WindFile`) that does not vary with time. At least one DOF must be enabled during a linearization analysis because it is useless to have a “plant” model with zero states. Finally, `CompNoise` must be disabled during a linearization analysis.

Inputs `CalcStdy`, `TrimCase`, `DispTol`, and `VelTol`, which are available in the linearization control-input-file of FAST (identified by parameter `LinFile` in FAST's primary input file), are the parameters used to manage the steady state solution computation in FAST.

Input parameter `CalcStdy` is a flag used to indicate whether a periodic steady state solution is computed before linearizing the model. To disable the steady state solution computation, set `CalcStdy` to False. In this case, the operating point is prescribed by the values of the initial conditions specified in FAST's primary input file. That is, when `CalcStdy` is False, the operating point is set to the condition in which all displacements, velocities, and accelerations are zero, except those specified with nonzero initial conditions (for instance, the azimuth DOF will increment at a constant rate if and when the rotor is spinning).

Setting `CalcStdy` to True causes FAST to compute a steady state solution before linearizing the model. During a steady state solution computation, FAST integrates the nonlinear equations of motion in time until the solution “converges”. “Convergence” is determined as follows. At each iteration, or one period of revolution of the rotor, a 2-norm of the differences between conditions at the beginning and end of the iteration is computed. A 2-norm is computed for both the angular displacement vector differences and angular velocity vector differences. Input parameters `DispTol` and `VelTol` are used as convergence tolerances for the displacement 2-norm and velocity 2-norm, respectively. The smaller the values of `DispTol` and `VelTol`, the tighter the tolerances. Once both of the computed 2-norms become smaller than or equal to the input convergence tolerances, the solution is considered to have “converged”. If the solution has not

converged by the time `TMax` is reached, the iteration stops and FAST aborts without computing the linearized state matrices. See Figure 28 for a schematic.

The calculation of an operating point depends on whether the rotor is spinning or stationary, whether the turbine is variable or constant speed, and whether the operating point is in Region 2 (below rated wind speed) or Region 3 (above rated wind speed). Again, see Figure 28 for a schematic.

To linearize a stationary HAWT, it is best to use the static equilibrium point as the steady state operating point. In this case, the steady state operating point is not periodic because the rotor is not spinning. To obtain the static equilibrium condition, set `CalcStdy` to True, `GenDOF` to False, and `RotSpeed` to zero. FAST will then integrate in time until the convergence tolerance conditions are met. This operation can be performed with or without aerodynamic thrust effects as indicated by input flag `CompAero`.

For variable speed wind turbines, one often wants to determine the periodic operating point in conjunction with a trim analysis. A trim analysis is the process of trimming a control input in order to reach a desired azimuth-averaged rotor speed while holding all other inputs constant. The FAST linearization functionality allows for three forms of trim as specified by input switch `TrimCase`. For all three cases, the desired azimuth-averaged rotor speed is prescribed by input parameter `RotSpeed` from the primary input file (which is also used as the initial rotor speed). Input parameter `TrimCase` is ignored when either `CalcStdy` or `GenDOF` is False.

For variable speed turbines in Region 2, set `CalcStdy` to True, `GenDOF` to True, `RotSpeed` to the desired azimuth-averaged rotor speed (nonzero), and `TrimCase` to 2. Setting `TrimCase` to 2 causes FAST to trim electrical generator torque, while maintaining constant rotor collective blade pitch (indicated by inputs `BIPitchi` from the primary input file), to reach the desired azimuth-averaged rotor speed condition.

For variable speed turbines in Region 3, set `CalcStdy` to True, `GenDOF` to True, `RotSpeed` to the desired azimuth-averaged rotor speed (nonzero), and `TrimCase` to 3. Setting `TrimCase` to 3 causes FAST to trim rotor collective blade pitch to reach the desired azimuth-averaged rotor speed condition. In this case, the initial “guess” blade pitch angles are given by `BIPitchi`, and the electrical generator torque is determined by the torque-speed relationship indicated by inputs `VSContrl` or `GenModel`. For typical Region 3 trim, collective pitch can be trimmed while maintaining a **constant** generator torque by setting `TrimCase` to 3, `VSContrl` to 1, `VS_RtTq` to the desired constant generator torque, and `VS_RtGnSp`,

`VS_Rgn2K`, and `VS_SIPc` to 9999.9E-9 (very small don't cares > 0.0).

The third trim option is for the nacelle yaw control input. To trim nacelle yaw, set `CalcStdy` to True, `GenDOF` to True, `RotSpeed` to the desired azimuth-averaged rotor speed (nonzero), and `TrimCase` to 1. Nacelle yaw can be trimmed with or without the yaw DOF enabled. With yaw DOF enabled (`YawDOF` = True), setting `TrimCase` to 1 causes FAST to trim the neutral yaw angle, `YawNeut`, which passes through FAST's built-in, second-order actuator model, while maintaining constant rotor collective blade pitch (indicated by inputs `BIPitchi` from the primary input file), to reach the desired azimuth-averaged rotor speed condition. In this case, the yaw actuator, which is described in the Nacelle Yaw Control section of the Controls chapter, will be inherent in the output linearized model. With yaw DOF disabled (`YawDOF` = False), setting `TrimCase` to 1 causes FAST to trim the **actual** nacelle yaw angle, while maintaining constant rotor collective blade pitch (indicated by inputs `BIPitchi` from the primary input file), to reach the desired azimuth-averaged rotor speed condition. In this case, the yaw actuator will be absent from the output linearized model.

For constant speed machines, set `GenDOF` to False. FAST will then ignore input `TrimCase`, and the trim analysis will be bypassed during the computation of the periodic steady state operating condition.

With or without trim, if a steady state solution has trouble converging, try increasing the simulation runtime, `TMax`; increasing system-damping values; or increasing the convergence tolerances, `DispTol` and `VelTol`. Some steady state solutions may take 300 seconds or more of simulation time to converge, depending on the nature of the wind turbine model, system-damping values, and convergence tolerances used. When trimming, also make sure that the condition you are trying to trim to is “reasonable”. For example, during Region 3 trim (`TrimCase` = 3), it may be impossible to find a rotor collective blade pitch angle at a given rotor speed and wind speed if the constant generator torque is too large. The steady state solution computation may become unstable if the initial guess of nacelle yaw is too large when trimming yaw (`TrimCase` = 1). During Region 2 trim (`TrimCase` = 2), the solution computation may also become unstable if your desired rotor speed is below the rotor speed that results in the maximum power coefficient at a given wind speed and rotor collective blade pitch angle. In this case, the only way to obtain a successful trim solution is to increase your desired rotor speed condition.

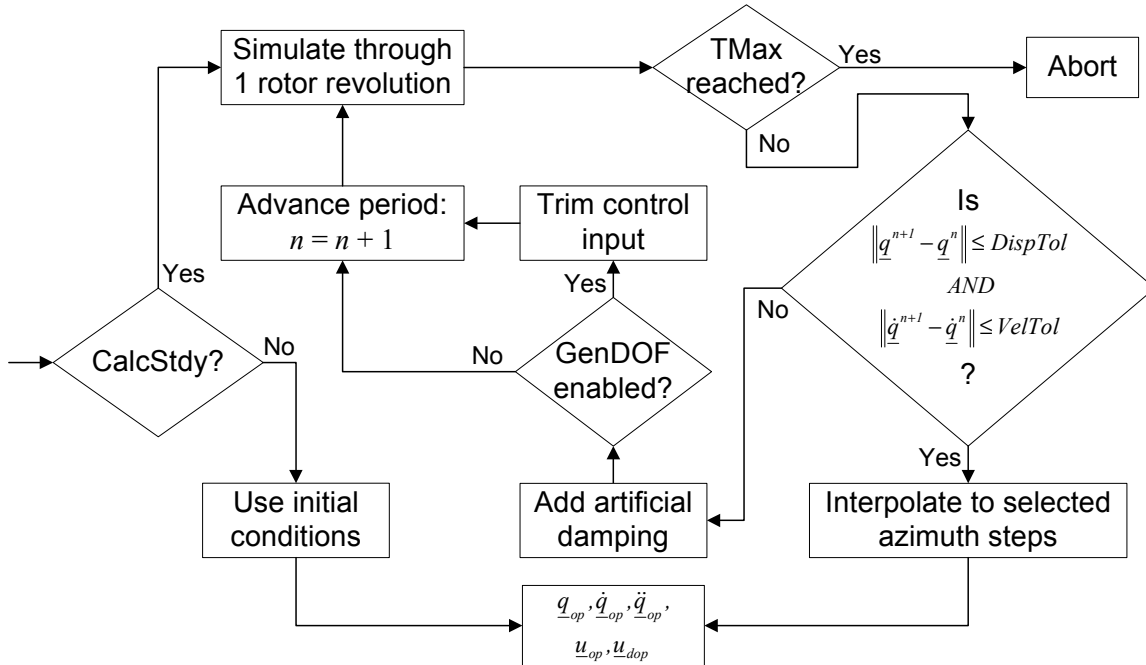

Figure 28. Periodic Steady State Computation.

Model Linearization

Once a periodic steady state solution has been found, FAST numerically linearizes the complete nonlinear aeroelastic model about the operating point. Since the operating point is periodic with the rotor azimuth position, the linearized representation of the model is also periodic. Inputs `NAzimStep`, `MdIOrder`, `NInputs`, `CntrlInpt`, `NDisturbs`, and `Disturbnc`, which are available in the linearization control-input-file of FAST (identified by parameter `LinFile` in FAST's primary input file), are the parameters used to manage the model linearization output.

FAST will output the periodic linearized model at a number of equally spaced rotor azimuth steps as indicated by input parameter `NAzimStep`. The first rotor azimuth location is always the initial azimuth position indicated by inputs `Azimuth` and `Azimb1Up`. The subsequent azimuth steps increment in the direction of rotation. Once a periodic steady state solution has been found, FAST interpolates the solution to these azimuth locations. If `RotSpeed` is zero, FAST will override `NAzimStep` and only linearize the model about the initial azimuth position (as if `NAzimStep` was set to 1). If you are interested in time-invariant control, you'll obtain a more accurate model if you output the linearized model at a number of different azimuth steps (by setting `NAzimStep` larger than 1) and then average the resulting matrices rather than using one azimuth location by setting `NAzimStep` equal to 1. A tool that will do this matrix

averaging for you is described in the Post Processing section below.

The FAST linearization routines can be used to develop both a first- and a second-order linearized representation of the nonlinear aeroelastic model. The order of the model is determined by input switch `MdIOrder`. To understand the difference between these representations, we must examine how the linearized state matrices relate to the nonlinear model.

The complete nonlinear aeroelastic equations of motion as modeled in FAST can be written as follows:

$$M(\underline{q}, \underline{u}, t) \ddot{\underline{q}} + \underline{f}(\underline{q}, \dot{\underline{q}}, \underline{u}, \underline{u}_d, t) = \underline{0}$$

where M is the mass matrix, \underline{f} is the nonlinear "forcing function" vector, \underline{q} is the vector of DOF displacements, (and $\dot{\underline{q}}$ and $\ddot{\underline{q}}$ are the DOF velocities and accelerations), \underline{u} is the vector of control inputs, \underline{u}_d is the vector of wind input "disturbances", and t is time. Note that in the steady state solution, only the DOF displacement, velocity, and acceleration vectors are periodic with the rotor azimuth position. The vector of control inputs and the vector of wind disturbances are not periodic. In the above notation, capital letters represent matrices and lower case underlined letters represent vectors.

FAST numerically linearizes the aeroelastic equations of motion by perturbing (represented by a Δ) each of the system variables about their respective operating point (op) values:

$$\underline{q} = \underline{q}_{op} + \underline{\Delta q}, \quad \underline{\dot{q}} = \underline{\dot{q}}_{op} + \underline{\Delta \dot{q}}, \quad \underline{\ddot{q}} = \underline{\ddot{q}}_{op} + \underline{\Delta \ddot{q}},$$

$$\underline{u} = \underline{u}_{op} + \underline{\Delta u}, \quad \text{and} \quad \underline{u}_d = \underline{u}_{dop} + \underline{\Delta u}_d.$$

Substituting these expressions into the equations of motion and expanding as a Taylor series approximation results in the second-order (MdlOrder equal 2) linearized representation of the equations:

$$M \underline{\Delta \ddot{q}} + C \underline{\Delta \dot{q}} + K \underline{\Delta q} = F \underline{\Delta u} + F_d \underline{\Delta u}_d,$$

where

$$M = M \Big|_{op}$$

is the mass matrix,

$$C = \frac{\partial f}{\partial \underline{\dot{q}}} \Big|_{op}$$

is the damping/gyroscopic matrix,

$$K = \left[\frac{\partial M}{\partial \underline{q}} \underline{\dot{q}} + \frac{\partial f}{\partial \underline{q}} \right] \Big|_{op}$$

is the stiffness matrix,

$$F = - \left[\frac{\partial M}{\partial \underline{u}} \underline{\dot{q}} + \frac{\partial f}{\partial \underline{u}} \right] \Big|_{op}$$

is the control input matrix, and

$$F_d = - \frac{\partial f}{\partial \underline{u}_d} \Big|_{op}$$

is the wind input disturbance matrix. The “ $\Big|_{op}$ ” notation is used to signify that the partial derivatives are computed at the operating point. Internally within FAST, these partial derivatives are computed using the central difference perturbation numerical technique.

Along with the linearized equations of motion, FAST also develops a linearized system associated with output measurements \underline{y} . The collection of output measurements is specified in list `OutList` at the end of the primary input file. The second-order linearized representation of the output system is as follows:

$$\underline{y} = VelC \underline{\Delta \dot{q}} + DspC \underline{\Delta q} + D \underline{\Delta u} + D_d \underline{\Delta u}_d$$

where *VelC* is the velocity output matrix, *DspC* is the displacement output matrix, *D* is the control input

transmission matrix, and *D_d* is the wind input disturbance transmission matrix.

The DOF displacement, velocity, and acceleration perturbation vectors ($\underline{\Delta q}$, $\underline{\Delta \dot{q}}$, and $\underline{\Delta \ddot{q}}$) are replaced with the first-order state vector \underline{x} and state derivative vector $\dot{\underline{x}}$:

$$\underline{x} = \begin{Bmatrix} \underline{\Delta q} \\ \underline{\Delta \dot{q}} \end{Bmatrix} \quad \text{and} \quad \dot{\underline{x}} = \begin{Bmatrix} \underline{\Delta \dot{q}} \\ \underline{\Delta \ddot{q}} \end{Bmatrix}$$

in order to determine the first-order (MdlOrder equal 1) representation of the system:

$$\dot{\underline{x}} = A \underline{x} + B \underline{\Delta u} + B_d \underline{\Delta u}_d$$

$$\underline{y} = C \underline{x} + D \underline{\Delta u} + D_d \underline{\Delta u}_d$$

In this form, the state matrix *A*, control input matrix *B*, wind input disturbance matrix *B_d*, and output state matrix *C* are related to their second-order counterparts as follows:

$$A = \begin{bmatrix} 0 & I \\ -M^{-1}K & -M^{-1}C \end{bmatrix}, \quad B = \begin{bmatrix} 0 \\ M^{-1}F \end{bmatrix},$$

$$B_d = \begin{bmatrix} 0 \\ M^{-1}F_d \end{bmatrix}, \quad \text{and} \quad C = [DspC \quad VelC]$$

where *I* is the identity matrix and *0* is a matrix of zeros. The control input transmission matrix *D* and wind input disturbance transmission matrix *D_d* are identical between the first- and second-order representations of the linearized system.

The sizes of the preceding matrices and vectors depend on the number of DOFs enabled and the number of control inputs and wind input disturbances selected. This is very convenient in controls-related work where it is useful to begin with a simple linearized “plant” model and then progressively add complexity in steps.

The number and type of DOFs incorporated in \underline{q} , $\underline{\dot{q}}$, and $\underline{\ddot{q}}$ are determined by the number of DOFs enabled. At least one DOF must be enabled during a linearization analysis because a “plant” model with zero states is useless.

The number and type of control inputs incorporated in \underline{u} are specified through input parameters `NInputs` and `CntrlInpt`. `NInputs` is the number of control inputs. Valid values are integers from 0 to 4 + `NumBl` (inclusive). `CntrlInpt` is a list of numbers corresponding to different types of control inputs. Possible values are 1 to 7 (inclusive) (7 is only available if `NumBl` = 3). The numbers correspond to

the seven control inputs described in Table 5. You must enter at least `NInputs` values in this list. You can separate the values with combinations of tabs, spaces, and commas, but you may use only one comma between numbers. If `NInputs` is 0, input parameter `CntrlInpt` will be skipped.

Table 5. Control Input Settings.

CntrlInpt Setting	Description
1	Nacelle yaw angle command
2	Nacelle yaw rate command
3	Electrical generator torque
4	Rotor collective blade pitch
5	Individual pitch of blade 1
6	Individual pitch of blade 2
7	Individual pitch of blade 3 (unavailable if <code>NumBl</code> = 2)

If the yaw DOF is enabled (`YawDOF = True`), then the commanded yaw angle and rate from `CntrlInpt` setting 1 and 2 are the neutral yaw angle, `YawNeut`, and neutral yaw rate, `YawRateNeut`, in FAST's built-in second-order actuator model. In this case, the yaw actuator, which is described in the Nacelle Yaw Control section of the Controls chapter, will be inherent in the output linearized model. If the yaw DOF is disabled (`YawDOF = False`), then the commanded yaw angle and rate from `CntrlInpt` setting 1 and 2 are the actual yaw angle and yaw rate. In this case, the yaw actuator will be absent from the output linearized model.

The number and type of wind input disturbances incorporated in \underline{u}_d are specified through input parameters `NDisturbs` and `Disturbnc`. `NDisturbs` is the number of wind input disturbances. Valid values are integers from 0 to 7 (inclusive). `Disturbnc` is a list of numbers corresponding to different types of wind input disturbances. Possible values are 1 to 7 (inclusive). The numbers correspond to the seven inputs available in the hub-height wind data files of AeroDyn as described in Table 6. You must enter at least `NDisturbs` values in this list. You can separate the values with combinations of tabs, spaces, and commas, but you may use only one comma between numbers. If `NDisturbs` is 0, input parameter `Disturbnc` will be skipped.

Table 6. Wind Input Disturbance Settings.

Disturbnc Setting	Description
1	Horizontal hub-height wind speed, <code>V</code>
2	Horizontal wind direction, <code>DELTA</code>
3	Vertical wind speed, <code>VZ</code>
4	Horizontal wind shear, <code>HSHR</code>
5	Vertical power law wind shear, <code>VSHR</code>
6	Linear vertical wind shear, <code>VLinSHR</code>
7	Horizontal hub-height wind gust, <code>VG</code>

As an example of the size of the output linearized state matrices, consider a three-bladed turbine (`NumBl` equal 3) modeled with only the `FlpDOF1` and `GenDOF` DOFs set to True (enabled). Assume also that `NInputs` is set to 2 with `CntrlInpt` set to 3,4 and `NDisturbs` is set to 1 with `Disturbnc` set to 1. This model has 4 DOFs (variable speed generator and one flap mode for each of the three blades), 2 control inputs (electrical generator torque and rotor collective blade pitch), and 1 wind input disturbance (horizontal hub-height wind speed). Thus, \underline{q} has size 4x1, \underline{x} has size 8x1, \underline{M} has size 4x4, \underline{A} has size 8x8, \underline{B} has size 8x2, \underline{B}_d has size 8x1, etc. If 12 parameters were listed in `OutList` in this example, then \underline{C} would have size 12x8, \underline{D} would have size 12x2, etc. Each of these matrices would be output at each of the `NAzimStep` number of equally spaced azimuth steps. Note also that if `NInputs` were set to 0 instead of 2 in this example, then the \underline{B} and \underline{D} matrices would be absent from the linearized system.

The name of the primary output file during a linearization analysis uses the path and root name of the primary input file and appends `.lin` for an extension. For example, if the input file were named `fast.fst`, the main output file will be named `fast.lin`. This output file contains the periodic state matrices of the linearized system, the periodic operating point states and state derivatives, the periodic operating point output measurements, the constant operating point values of the control inputs and wind inputs, and other information that is useful for post processing and for making use of the linearized model. An example linearized model file is shown in Figure 31.

Post Processing

The numerous output vectors and matrices may be overwhelming, and one may wonder how to analyze and make use of them. To aid in this effort, we have developed a post processing script file in MATLAB entitled `Eigenanalysis.m`. This script file is included in the FAST archive in the `CertTest` folder. This script file can be used as a basis for more advanced utilization of the FAST linearization output. It is

written in MATLAB because MATLAB is the tool most commonly used in controls-related design work.

To run the *Eigenanalysis.m* script file, open a MATLAB command window, change the current working directory to the directory in which the script file is stored, and type “Eigenanalysis” into the MATLAB command prompt. The script file will prompt you for the name of the FAST linearization output file to process. Type only the root name of this file—omit the *.lin* extension. The name may optionally include an absolute or relative path if *Eigenanalysis.m* is not stored in the same directory as the FAST linearization output file. Naturally, a FAST linearization analysis must be run before the *Eigenanalysis.m* script file is run, and a linearization output file must be available for processing.

Running *Eigenanalysis.m* will cause MATLAB to read in the periodic state matrices from the FAST linearization output file. If the linearized model is second-order, the script will then compute the first-order state matrices from the second-order matrices using the equations documented above. If the linearized model is first-order, the script will **not** compute the second-order matrices from the first-order state matrices because the process cannot be reversed (there is no unique solution available without

knowledge of the mass matrix). The form of the state matrix A without damping (as if C were zero) is computed next. Azimuth-averaged matrices are then computed for all available periodic matrices. Finally, the script will perform an eigenanalysis on the periodic and azimuth-averaged state matrix A , with and without damping. The resulting eigenvalues and eigenvectors are the full system natural frequencies and mode shapes. The natural frequencies are available in both rad/sec and Hz.

After the script file has completed execution, type “who” into the MATLAB command prompt. This will cause MATLAB to list the available variables. The variable names are descriptive enough that they can be discerned without further documentation. For example, the azimuth-averaged full system natural frequencies of the nondamped system, in Hz, are available in variable `FrequenciesAvgHzNoDamp`. Their associated mode shapes are available in variable `ModeShapesAvgNoDamp`.

Please refer to MATLAB documentation for additional help on running MATLAB and learning commands that are useful for controls-related design work, which make use of linearized models output from FAST.

ADAMS PREPROCESSOR

General Description

FAST has the capability of extracting “equivalent” ADAMS (Automatic Dynamic Analysis of Mechanical Systems) wind turbine datasets from the turbine properties specified in the FAST input file(s). That is, FAST has the functionality of acting like an ADAMS preprocessor capable of creating ADAMS datasets of wind turbine models through FAST’s simple property-input-style interface. Thus, FAST can be used as an alternative to the ADAMS/WT toolkit (12) or other preprocessors used to create ADAMS datasets of wind turbine models. The FAST to ADAMS preprocessor feature is enabled through the switch `ADAMSPrep` in the primary input file. This chapter, which describes the FAST to ADAMS preprocessor, assumes the reader is familiar with the basics of ADAMS.

The main advantages for using FAST to create ADAMS datasets are to ensure consistency between FAST and ADAMS models and to facilitate quick and easy creation of ADAMS datasets. The FAST-to-ADAMS preprocessor supports the mentality that all pertinent configuration information be stored in a single location (i.e., the FAST input files). The FAST to ADAMS preprocessor provides a natural progression from the medium-complexity FAST wind turbine models to the highly complex models possible using ADAMS. Once a working FAST model has been developed, little additional effort is required to create the more advanced ADAMS model. This is a useful way to impress your boss—you can accomplish a lot of work with very little effort. ☺

The ADAMS datasets extracted from FAST contain all the functionality and usability associated with the FAST model, while bypassing some of FAST’s limitations. All the turbine control paradigms available in FAST, as discussed in the Controls chapter, are incorporated into the ADAMS model. These include the functionality of yawing the nacelle, pitching the blades, controlling the generator and HSS brake torque, and deploying the tip brakes. The ADAMS datasets incorporate the same generator, drivetrain compliance, nacelle yaw, rotor-furl, tail-furl, rotor teeter, and support platform models and DOFs used by FAST. Also, all of the output parameters specified at the end of FAST’s primary input file are passed into the ADAMS datasets. This eliminates the need to develop a `REQSUB()` user-written subroutine for request output every time an ADAMS dataset is generated. Once an ADAMS analysis is run, the format of the ADAMS output file containing time-series data is identical to that of the FAST format so

that post-processing techniques are compatible for the codes.

Additionally, the ADAMS interface is developed in such a way that all user-defined routines developed for FAST, including `UserGen()`, `UserVSCont()`, `UserHSSBr()`, `UserPtfmLd()`, `UserTeet()`, `UserRFrl()`, `UserTFrl()`, `UserTFin()`, `UserYawCont()`, and `PitchCntrl()`, can be linked with ADAMS just as easily as they can be with FAST. The routines do not need to be modified in any way for compatibility with ADAMS. The AeroDyn input files are also fully compatible between the FAST models and the associated, extracted ADAMS datasets.

One of FAST’s limitations that is bypassed by ADAMS is the assumed-mode approximation of the blades and tower. The blades and tower of the extracted ADAMS model are developed from FAST’s distributed mass and stiffness inputs using ADAMS’ conventional approach of modeling flexible members through a series of lumped masses connected by stiffness and damping `FIELDS`. Nevertheless, FAST’s valuable DOF-switching functionality is still available in the ADAMS model, so these flexibilities can be eliminated through a simple flag, just as they can be in FAST (in ADAMS the flexibilities are eliminated collectively, not one mode at a time).

Moreover, several characteristics not implemented in the FAST model are incorporated into the extracted ADAMS model. These include torsional and extensional DOFs for the blades and tower, flap/twist coupling in the blades, precurved and preswept blades, mass and elastic offsets for the blades, mass offsets for the tower, actuator dynamics for the blade pitch controls, graphical output capabilities, and others documented below.

Compiling and Linking ADAMS

Using the extracted ADAMS datasets requires the purchase and installation of the commercial ADAMS multibody-dynamics and analysis package. ADAMS is available from MSC.Software Corporation of Santa Ana, California. You will also need a compiler. For the PC, you should use the Compaq Visual Fortran compiler, but its predecessor, Digital Fortran, will also work.

Additionally, one must download the ADAMS to AeroDyn (A2AD) source files (13) and compile and link the ADAMS user-created dynamic-link-library (DLL). This is where the compiler is required.

The A2AD archive is available for download from our [Web page](http://wind.nrel.gov/designcodes/simulators/adams2ad/) <http://wind.nrel.gov/designcodes/simulators/adams2ad/>. The source files included in the archive, which are

pertinent to creating the DLL needed to run the ADAMS datasets extracted from FAST, are as follows:

<i>GFOSUB.f90</i>	Contains an interface for the user-defined support platform loading model and routines that interface ADAMS to AeroDyn so that AeroDyn can provide ADAMS with aerodynamic forces on each blade element.
<i>SENSUB.f90</i>	Contains a routine to detect the occurrence of a successful forward time step. This is needed for the AeroDyn interface.
<i>REQSUB_FAST.f90</i>	Contains routines for calculating the desired ADAMS output as specified in FAST's primary input file.
<i>SFOSUB_FAST.f90</i>	Contains a routine for implementing the generator and variable-speed control models and an interface for the user-defined rotor teeter, rotor-furl, and tail-furl spring and damper models.
<i>VARSUB_FAST.f90</i>	Contains a routine for computing the demand blade pitch angles and demand nacelle yaw angle and rate.
<i>VFOSUB_FAST.f90</i>	Contains routines for computing the tip-brake drag and tail fin aerodynamic forces.

Source files *GFOSUB.f90* and *SENSUB.f90* are the generic routines provided in the A2AD archive for interfacing any ADAMS model to AeroDyn. A good description of these files is provided in (13). *GFOSUB.f90* had to be modified slightly in order to incorporate an interface to the user-defined support platform loading model contained in routine *UserPtfmLd()*. Source files *REQSUB_FAST.f90*, *SFOSUB_FAST.f90*, *VARSUB_FAST.f90*, and *VFOSUB_FAST.f90* were written explicitly for running ADAMS datasets extracted from FAST.

Also included in the A2AD archive is a file named *CompileLinkA2AD.bat*. This is a DOS command script useful for compiling and linking the ADAMS DLL, named appropriately, *ADAMS.dll*. You will need to modify this script before you can run it on your PC. Open the script with your favorite editor. You will need to change the variables *DF_LOC*, *A2AD_LOC*, *AD_LOC*, and *FAST_LOC*. Set them so they point to the locations of Digital Fortran and the A2AD, AeroDyn, and FAST source files respectively. The location of the FAST source files is needed so that the

same user-defined routines developed for FAST, including *UserGen()*, *UserVSCont()*, *UserHSSBr()*, *UserPtfmLd()*, *UserTeet()*, *UserRFrl()*, *UserTFrl()*, *UserTFin()*, *UserYawCont()*, and *PitchCntrl()*, can be used with the ADAMS model as well.

Once these path variables are set, save the updated script and run it from a command prompt by simply typing its name. You can also run the script by double-clicking on it from Windows Explorer. Note that a file named *newline.txt*, which is also contained in the A2AD archive, must be located in the same directory as the *CompileLinkA2AD.bat* script in order for the script to work. The script will create *ADAMS.dll*. This one DLL can be used to run **any** ADAMS datasets extracted from FAST. In other words, you will only need to create *ADAMS.dll* **once** (unless you change any of the user-defined routines or source files).

Guidelines for Creating ADAMS Datasets

Here is the recommended procedure for creating ADAMS datasets using the FAST to ADAMS preprocessor:

Step 1. Create a working FAST model. Do this by specifying the desired settings in the FAST input files, running a simulation, and then verifying that the response predictions are reasonable.

One drawback to creating both FAST and ADAMS models from the same input file(s) is that if an error is made when inputting properties for a FAST model, the extracted ADAMS model will contain the same error. All redundancy checks available when FAST and ADAMS models are created independently are eliminated. To minimize resulting repercussions, make sure that the FAST model is in working order and is outputting reasonable response predictions before creating the ADAMS datasets.

Step 2. Update the FAST input files to include the additional input specifications required for creating ADAMS datasets.

The creation of ADAMS datasets using the FAST to ADAMS preprocessor requires the specification of additional parameters in the input file *ADAMSFile*. This file contains ADAMS-specific inputs related to the blade pitch actuators, graphical output capabilities, and other ADAMS-specific functionalities.

Furthermore, additional distributed blade and tower stiffness and inertial properties must be specified in the blade and tower input files. These are input by including additional columns of distributed data. For the blades, the additional columns are for distributed torsional and extensional stiffnesses, the distributed flap/twist coupling coefficient, distributed inertias, distributed offsets for identifying the reference axis for precurved and preswept blades, and distributed mass and elastic offsets. For the tower, the additional columns are for distributed torsional and extensional

stiffnesses, distributed inertias, and distributed mass offsets. See the sample input files and the Input Files chapter for more details on these additional inputs.

Several input parameters are handled differently between FAST and the ADAMS preprocessor. Users of the FAST to ADAMS preprocessor should be aware of these differences.

The time step size input parameter, *DT*, is used by the ADAMS preprocessor to specify the maximum step size the integrator is allowed to take in the variable-step-size numerical-integration scheme that is used by ADAMS. Users of the ADAMS preprocessor should be aware that this is in slight contradiction to how *DT* is used to specify the constant time step size for the numerical integration scheme that is used by FAST.

Since the blade and tower models incorporated into the ADAMS datasets do not operate on the modal principle, input parameters associated with modal properties are naturally handled differently in the ADAMS preprocessor.

Blade flap and edge damping ratios incorporated in ADAMS FIELD statements are set equal to the same ratios used for the **first** flap and edge modes in FAST. These ratios are determined by inputs *BldFIDmp(1)* and *BldEdDmp(1)* in the blade input file(s). The value of input *BldFIDmp(2)* does not affect the creation of ADAMS datasets.

Likewise, tower fore-aft and side-to-side damping ratios incorporated in ADAMS FIELD statements are set equal to the same ratios used for the **first** fore-aft and side-to-side modes in FAST. These ratios are determined by inputs *TwrFADmp(1)* and *TwrSSDmp(1)* in the tower input files. The values of inputs *TwrFADmp(2)* and *TwrSSDmp(2)* do not affect the creation of ADAMS datasets.

Moreover, the modal stiffness tuner input parameters contained in the blade and tower data files are completely ignored by the ADAMS preprocessor.

Blade flexibility is controlled by enabling the first blade modes through input flags *FlapDOF1* and *EdgeDOF*. Enabling blade flexibility enables all blade flap, edge, torsional, and extensional DOFs; conversely, disabling the flexibility removes all of these DOFs. When using the ADAMS extractor, the setting of *FlapDOF1* must be identical to that of *EdgeDOF* to emphasize that the flap DOFs can't be enabled without also enabling edge DOFs or vice-versa. The setting of input flag *FlapDOF2* does not affect the creation of the ADAMS datasets.

Tower flexibility is controlled by enabling the first tower modes through input flags *TwFADOF1* and *TwSSDOF1*. Enabling tower flexibility enables all tower fore-aft, side-to-side, torsional, and extensional DOFs, and conversely, disabling the flexibility removes all of these DOFs. When using the ADAMS extractor, the setting of *TwFADOF1* must be identical to that of *TwSSDOF1* to emphasize that the fore-aft

DOFs can't be enabled without also enabling side-to-side DOFs or vice-versa. The setting of input flags *TwFADOF2* and *TwSSDOF2* do not effect the creation of the ADAMS datasets.

Support platform rotational DOFs are controlled by enabling input flags *PtfmRDOF*, *PtfmPDOF*, and *PtfmYDOF*. Due to the method ADAMS uses to implement the rotational DOFs, FAST cannot build an ADAMS dataset if one of the platform rotational DOFs is set differently than the other two. Thus, you must set *PtfmRDOF*, *PtfmPDOF*, and *PtfmYDOF* to the same value (i.e., **all** *.True* or **all** *False*). There is **no** restriction on which combination of support platform translational DOFs are enabled.

Additionally, some features available in FAST can't be modeled in ADAMS. Thus, when creating ADAMS datasets using the FAST to ADAMS preprocessor, FAST will abort and not create the ADAMS dataset if any of these features are selected.

Mechanical gearbox efficiency losses are very difficult to model in ADAMS. Thus, *GboxEff* must be set to 100% when creating ADAMS datasets. Similarly, the physics of a gearbox whose LSS and HSS rotate in opposite directions are difficult to model in ADAMS. Thus, *GBRevers* must be set to *False* when creating ADAMS datasets.

The initial displacements of the blades and tower, specified using inputs *OopDefl*, *IPDefl*, *TTDspFA*, and *TTDspSS*, must all be zero when creating ADAMS datasets. This is due to the difficulty involved in assembling an ADAMS dataset that contains deflected flexible members at the model definition phase. The initial teeter angle, *TeetDefl*, must also be set to zero when creating ADAMS datasets. This restriction exists since the generic *GFOSUB.f90* routines provided in the A2AD archive will not read initial blade element data properly if *TeetDefl* is nonzero. All of the other initial conditions specified in FAST's primary input file, including the initial rotor speed (*RotSpeed*), are incorporated in the ADAMS datasets.

Due to a restriction in ADAMS, the title line of FAST's primary input file, the third line in the file, must not contain any of the characters *“,”*, *“;”*, *“&”*, or *“!”* when creating ADAMS datasets. This is because the title is stored as a STRING statement in the ADAMS datasets (used for providing header information in the primary output file) and because ADAMS STRING statements prohibit the use of these characters.

Sensible limits are placed on the number of blade and tower elements so that a reasonable numbering scheme could be implemented for ADAMS blade and tower PART, MARKER, and FIELD statements. This restriction is that neither *TwrNodes* nor *BldNodes* can be greater than 99.

Finally, users of the FAST-to-ADAMS preprocessor should also be aware that the linearization control features and Simulink interface available in FAST are not available in the extracted ADAMS models.

Step 3. Run FAST with ADAMSPrep set at 2 or 3. When ADAMSPrep is set to 2, FAST creates the ADAMS datasets and stops. When ADAMSPrep is set to 3, FAST creates the ADAMS datasets and then proceeds to run the FAST simulation as well.

When running, FAST generates two ADAMS files as follows:

`<RootName>_ADAMS.adm`

The ADAMS dataset containing statements that characterize the model configuration, analysis settings, and output.

`<RootName>_ADAMS.acf`

The ADAMS command file containing statements that enable DOFs and drive the time-marching simulation.

where *RootName* is the name of the primary input file. For example, if the input file were named *fast.fst*, the extracted ADAMS files will be named *fast_ADAMS.adm* and *fast_ADAMS.acf*.

An additional file named `<RootName>_ADAMS_LIN.acf` is generated when flag `MakeLINacf` is enabled in the `ADAMSFile`. This third file contains statements that drive an ADAMS/LINEAR eigenanalysis of the model. The eigenanalysis is performed with no gravity, rotor speed, damping, or aerodynamics, no matter how the associated inputs are otherwise specified in FAST's input files.

If you want to change the ADAMS model properties or analysis settings, simply change the desired input properties in the FAST input file(s) and run FAST again to create the updated ADAMS datasets. This causes FAST to overwrite your old datasets if they are located in the same directory in which FAST is called. You never need to manually change the ADAMS datasets unless you want to change the ADAMS model to include features not supported by the FAST-to-ADAMS preprocessor.

Before running the ADAMS simulation, it may be beneficial to examine the model in ADAMS View to make sure the configuration is as expected. To do this, open ADAMS View, choose Import... from the File menu, and then browse and select the ADAMS dataset (*.adm*) of interest.

Running ADAMS

Before running ADAMS, it is imperative that you first understand FAST. This is because the extracted ADAMS datasets are considerably more complex than

their associated FAST models. Please refer to Step 1 of the previous section for additional information regarding this issue.

Using *ADAMS.dll*, an extracted ADAMS dataset, and an extracted ADAMS control/command file, you can run the ADAMS simulation using the Run Custom Solver prompts available in ADAMS Solver. Experienced users of ADAMS can also develop script files so that *ADAMS.dll* can be run from any directory without manually going through the ADAMS Solver prompts.

In order to get the ADAMS simulation to run smoothly and converge accurately, you will most likely need to play around with the time step size and integrator error. The FAST-to-ADAMS preprocessor automatically enters a default integrator error of 0.001 for all of the ADAMS INTEGRATOR/GSTIFF statements. This should be suitable for most simulations, but may require adjustment for some.

Please refer to (13) for additional hints on running ADAMS simulations.

ADAMS generates several output files. The primary output file of interest has a *.plt* (for plot) extension. This file contains the columns of time-series data with one column for each parameter that is requested in the primary input file. The format of this output file is identical to that of FAST's *.out* file so that post-processing techniques are compatible for the codes. The other files created are generic ADAMS output files generated by ADAMS Solver. It may or may not be useful to review these.

When examining time-series data output from ADAMS, please be aware of the following limitations. If the tower is rigid, the tower base loads will all be output with zeros—unfortunately, we haven't found a reason or workaround for this anomaly. Also, when outputting local span blade loads, be aware that the loads at the outboard strain gages will be under-predicted by ADAMS. This is because ADAMS lumps all of its mass at the center of each segment (rigid body inertia effects are also included), and thus, the mass of the segment in which the local span loads are output does not contribute to the local load. This difference shows most in the outboard part of the blade and becomes insignificant toward the root. Finally, be aware that the gyroscopic pitching moments induced when the nacelle yaws while the drivetrain is spinning will be over-predicted by ADAMS. This results from the fact that the HSS is lumped to the LSS in the ADAMS model. A detailed explanation of why this lumping affects the gyroscopic pitch moments is provided in (6).

If `SaveGrphcs` is enabled in `ADAMSFile`, ADAMS will also generate a graphics output file with a *.gra* extension. The graphics output file may be used to view an animation of the ADAMS simulation. To view the simulation, open ADAMS View, choose

Import... from the File menu, and then browse and select the ADAMS graphics file of interest. Once loaded, the animation can be played by choosing Animation Controls... from the Review menu. When running **many** ADAMS simulations, it is beneficial to disable **SaveGrphcs**—ADAMS will not then generate the graphics output file and will run faster as a result.

When ADAMS is run using the control/command file for the ADAMS/LINEAR analysis, a results output file with a *.res* extension is generated. To animate the system mode shapes, open ADAMS View, choose Import... from the File menu, and then browse and select the ADAMS results file of interest. Once loaded, the system modes can be animated by choosing Linear Modes Controls... from the Review menu. If you only require a listing of the system natural frequencies, these results are written and can be retrieved from either the *.out* (output) or *.msg* (message) files automatically generated by ADAMS Solver.

Description of the Extracted ADAMS Datasets

This section documents qualitatively how the extracted ADAMS datasets are organized and how the various components of the wind turbine model are implemented in ADAMS. If you are interested in manually modifying the ADAMS datasets in order to incorporate features not available by the FAST-to-ADAMS preprocessor, it is important to review this section first. If you have no interest in learning how the various components of the wind turbine model are implemented in ADAMS, you may skip this section entirely.

To learn the exact details on how the ADAMS datasets are generated, see the file *FAST2ADAMS.f90* in the FAST source code. This Fortran file contains three subroutines, one for generating each of the ADAMS files output by FAST.

In general, the ADAMS datasets generated by FAST employ the same PART and MARKER numbering conventions as recommended in (13). For reference, a complete listing of all of the ADAMS statements (PARTs, MARKERs, FIELDs, JOINTs, etc.) contained in the extracted ADAMS datasets is provided on our Web page <http://wind.nrel.gov/designcodes/simulators/adams2ad/FAST2ADAMSStatements.xls>. However, not all extracted ADAMS datasets contain every statement documented in this spreadsheet—only statements that are needed are included. For example, if the generator speed is held fixed by disabling the generator DOF, then the SFORCE statement used to model an unneeded generator torque will not be included in the ADAMS dataset.

When examining the ADAMS datasets, it is important to note that the system units for all

statements in the ADAMS datasets are in kilonewtons, kilograms, meters, and seconds for the force, mass, length, and time units respectively. These are specified through the use of a UNITS statement. The acceleration of gravity, specified using an ACCGRAV statement, acts in the negative z-direction of the GROUND reference frame and MARKER.

The ADAMS dataset containing statements that characterize the model configuration, analysis settings, and output (the *.adm* file) is organized into five main sections. The first is a header section containing comments that identify the model name and describe how and when the dataset was created. The second section contains definitions of all model PART, MARKER, and GRAPHICS statements. The third section contains the constraint JOINT and MOTION statements, and the fourth section contains force definitions, including FIELD, FRICTION, SFORCE, VFORCE, GFORCE, and SPRINGDAMPER statements. The last section contains definitions of analysis settings and output.

In each section that contains model definition statements, the model is assembled from the ground up, from the support platform through the blade tip. So, for example, if you want to examine the tower FIELD statements, look at the statements near the beginning of the force definition section.

The ADAMS command (*.acf*) files contain commands used to drive the simulation. These include an INTEGRATOR statement and either SIMULATE/DYNAMICS or LINEAR/EIGENSOL commands, depending on the type of analysis performed. The *.acf* files also contain DEACTIVATE commands used to remove superfluous constraints and enable DOFs based on the specifications in the feature flags section of FAST's primary input file. Additional details on this last point are provided at the end of this section.

Each tower and blade element is characterized by its own PART statement. The center of mass MARKERs of these PARTs are located at the same vertical (for tower) and radial (for blade) locations as the analysis nodes used in FAST. For blades, the transverse locations of the center of mass MARKERs are positioned with the reference axis and center-of-gravity offsets specified in the blade input file. For towers, the transverse locations of the center of mass MARKERs are identified using the distributed center-of-gravity offsets specified in the tower input file. Interconnecting each PART is a stiffness and damping FIELD statement. The FIELDs attach to the PARTs at elastic axis MARKERs, which are located in the same transverse planes as the center of mass MARKERs of each PART. For the blades, the transverse locations of the elastic axis MARKERs are identified using the distributed reference axis and elastic-axis offsets

specified in the blade file, and for the tower, are assumed coincident with the tower axis.

Users should note that a flexible member (a blade or tower) with “N” analysis nodes, will be assembled using “N+1” FIELD statements. “N-1” of the FIELD statements are used to interconnect the “N” analysis nodes to each another. The “Nth” FIELD statement is used to cantilever node 1 to the flexible member’s rigid base. The “(N+1)th” FIELD statement is used to connect node “N” to the tip of the flexible member, which for the tower is the tower-top and for a blade is the tip brake. For blades with no tip brakes (indicated by setting the associated `TipMass` to zero), the DOFs associated with the outermost FIELD statement are never enabled.

The support platform, tower top, bed plate, nacelle, generator, HSS, LSS, teeter pin, hub, pitch plates, tip brakes, tail, and structure furling with the rotor are all modeled using rigid PART statements. Each of these PARTs contains several MARKERS for identifying various locations and directions.

In the graphics output, each tower and blade element is identified with its own unique GRAPHICS statement. Additional GRAPHICS statements are used to illustrate the rigid tower base, nacelle, gearbox, HSS, LSS, generator, hub, tail boom, and tail fin.

The yaw bearing is modeled with a revolute JOINT. Nacelle yaw demand angles and rates, arising from both advanced yaw control algorithms and override yaw maneuver specifications, are computed in `VARSUB()` and stored in VARIABLE statements. If necessary, based on settings in FAST’s primary input file, routine `VARSUB()` calls FAST’s user-defined yaw control routine, `UserYawCont()`. The difference between the yaw demand angle and actual yaw angle (yaw error) and the yaw demand rate and actual yaw rate (yaw rate error) is passed through a yaw actuator model that is implemented with an explicit function-based SFORCE statement. This is the same yaw actuator inherent in equivalent FAST models. If the yaw DOF is disabled, the yaw JOINT is “locked” using a steady MOTION statement, but the yaw DOF cannot be disabled if yaw control is enabled (the ADAMS preprocessor will abort if you try).

The rotor-furl bearing is modeled with a revolute JOINT. When `RFrlMod` is set to 1, the standard, linear compliance is modeled with a rotational SPRINGDAMPER statement and the nonlinear up- and down- spring and damper stops are modeled with explicit function-based SFORCE statements. When `RFrlMod` is set to 2, the user-defined rotor-furl spring and damper model provided in routine `UserRFrl()` is interfaced to ADAMS from routine `SFOSUB()`, which in turn, is called from an SFORCE statement. If the rotor-furl DOF is disabled, the rotor-furl JOINT is “locked” using a steady MOTION statement.

Likewise, the tail-furl bearing is modeled with a revolute JOINT. When `TFrlMod` is set to 1, the standard, linear compliance is modeled with a rotational SPRINGDAMPER statement and the nonlinear up- and down- spring and damper stops are modeled with explicit function-based SFORCE statements. When `TFrlMod` is set to 2, the user-defined tail-furl spring and damper model provided in routine `UserTFrl()` is interfaced to ADAMS from routine `SFOSUB()`, which in turn, is called from an SFORCE statement. If the tail-furl DOF is disabled, the tail-furl JOINT is “locked” using a steady MOTION statement.

Low-speed shaft compliance is modeled with a revolute JOINT and a rotational SPRINGDAMPER statement. When drivetrain rotational flexibility is disabled, the JOINT is “locked” with a zero-valued MOTION statement.

Drivetrain torque models, including both the generator models and variable-speed control models, are implemented with an SFORCE (1-component scalar force) statement that calls routine `SFOSUB()`. This routine implements each type of drivetrain torque model available in FAST. The parameters passed to `SFOSUB()` depend on the type of drivetrain torque model selected in FAST’s primary input file. If necessary, `SFOSUB()` will call the user-defined `UserGen()` or `UserVSCont()` routines.

The high-speed shaft brake is implemented with a preload-only FRICTION statement. Since the magnitude of the preload torque cannot be time-varying, the full friction torque is applied throughout the entire simulation. To negate the unwanted resistance before `THSSBrDp`, an SFORCE statement that calls `SFOSUB()` is used to apply a cancellation torque between the shaft and the nacelle. The `SFOSUB()` also applies the linear ramping component of the braking torque (over time increment `HSSBrDT`) when `HSSBrMode` is set to 1. Alternatively, `SFOSUB()` calls FAST’s user-defined HSS brake routine `UserHSSBr()` to determine the fraction of torque to cancel out when `HSSBrMode` is set to 2.

The teeter bearing is modeled with a revolute JOINT. When `TeetMod` is set to 1, the standard, nonlinear teeter spring and damper models are implemented with explicit function-based SFORCE statements. When `TeetMod` is set to 2, the user-defined teeter spring and damper model provided in routine `UserTeet()` is interfaced to ADAMS from routine `SFOSUB()`, which in turn, is called from an SFORCE statement. If the teeter DOF is disabled, the teeter JOINT is “locked” using a steady MOTION statement.

The blade pitch bearing is modeled with a revolute JOINT. Blade pitch demand angles, arising from both advanced pitch control algorithms and override pitch maneuver specifications, are computed in `VARSUB()`

and stored in VARIABLE statements. If necessary, based on settings in FAST's primary input file, routine VARSUB() calls FAST's user-defined pitch control routine, PitchCntrl(). The difference between the pitch demand angle and actual pitch angle (pitch error) is passed through a pitch actuator model that is implemented with an explicit function-based SFORCE statement. If pitch is not actively controlled during the simulation, the pitch JOINT is "locked" using a steady MOTION statement.

As described in the A2AD User's Guide (13), ADAMS is interfaced to AeroDyn through routines provided in the A2AD source file *GFOSUB.f90*. Routine GFOSUB(), which is contained in *GFOSUB.f90*, is called from GFORCE (6-component general force) statements placed in the ADAMS dataset. There is one GFORCE statement for each blade analysis node (or element) in every blade.

A GFORCE statement, together with the GFOSUB(), is also used to interface ADAMS with the user-defined support platform loading model, routine UserPtfmLd().

Tip-brake drag forces are modeled using VFORCE (3-component vector force) statements that call routine VFOSUB(). The VFOSUB() routine employs the same simple logic FAST uses for computing tip brake drag forces.

Tail fin aerodynamic loads are also modeled using a VFORCE (3-component vector force) statement that calls routine VFOSUB(). When TFinMod is set to 1, the VFOSUB() routine employs the same simple logic FAST uses for computing the tail fin aerodynamic loads. When TFinMod is set to 2, the user-defined tail fin aerodynamic model provided in routine UserTFin() is interfaced to ADAMS from routine VFOSUB().

All output parameter names, units, and identifiers are stored in the ADAMS dataset using ARRAY and STRING statements. These are read in by routines in

the A2AD source file *REQSUB_FAST.f90* to determine which channels to output. Additional parameters needed for computing output data are passed to REQSUB(), a routine contained in file *REQSUB_FAST.f90*. Routine REQSUB() is, in turn, called using a REQUEST statement in the ADAMS dataset.

No matter which DOFs are enabled when generating the ADAMS datasets with the FAST-to-ADAMS preprocessor, the ADAMS dataset is always assembled so that it possesses no DOFs upon initiation. That is, all DOFs are essentially "locked" during the model-loading phase. This is achieved by placing fixed JOINTs between each PART of the flexible blades and tower, placing an ORIENTATION JOINT between the GROUND and support platform PART, and by specifying steady MOTION statements at all revolute JOINTs for the yaw, rotor-furl, tail-furl, teeter, shaft, and blade pitch bearings.

Once the simulation begins using the ADAMS command (.acf) file, the first time step is processed with all the DOFs "locked". After the first time step, the selected DOFs are enabled by removing the superfluous MOTION, JPRIM, and fixed JOINT statements through the use of DEACTIVATE commands. Processing the first time step with zero DOFs ensures that the initial condition solution, which always precedes the first SIMULATE/DYNAMICS event, does not "kick" the system when the rotor is initially spinning at some nonzero-valued rate. Instead, the simulation always begins with no initial deflections. This technique essentially bypasses the startup problems pertaining to most ADAMS datasets as discussed in (13). The transient behavior associated with the startup of an ADAMS analysis, should be nearly identical to that associated with the startup of a corresponding FAST analysis.

INPUT FILES

Sample Input Files

The sections that follow describe the format of the various program input files. In the FAST archive, we provide a sample set of 17 models, including all

pertinent input files. Table 7 provides a general description of these sample models. The sample input files associated with these models are available in the *CertTest* folder and should be used as templates for creating your own models.

Table 7. Sample Models Provided with the FAST Archive.

Test Name	Turbine Name	No. Blades (-)	Rotor Diameter (m)	Rated Power (kW)	Test Description
Test01	AWT-27CR2	2	27	175	Flexible, fixed yaw error, steady wind
Test02	AWT-27CR2	2	27	175	Flexible, start-up, HSS brake shut-down, steady wind
Test03	AWT-27CR2	2	27	175	Flexible, free yaw, steady wind
Test04	AWT-27CR2	2	27	175	Flexible, free yaw, turbulence
Test05	AWT-27CR2	2	27	175	Flexible, generator start-up, tip-brake shutdown, steady wind
Test06	AOC-15/50	3	15	50	Flexible, generator start-up, tip-brake shutdown, steady wind
Test07	AOC-15/50	3	15	50	Flexible, free yaw, turbulence
Test08	AOC-15/50	3	15	50	Flexible, fixed yaw error, steady wind
Test09	UAE VI downwind	2	10	20	Flexible, yaw ramp, steady wind
Test10	UAE VI upwind	2	10	20	Rigid, power curve, ramp wind
Test11	WP 1.5 MW	3	70	1500	Flexible, variable speed & pitch control, pitch failure, turbulence
Test12	WP 1.5 MW	3	70	1500	Flexible, variable speed & pitch control, ECD event
Test13	WP 1.5 MW	3	70	1500	Flexible, variable speed & pitch control, turbulence
Test14	WP 1.5 MW	3	70	1500	Flexible, stationary linearization, vacuum
Test15	SWRT	3	5.8	10	Flexible, variable speed control, free yaw, tail-furl, EOG01 event
Test16	SWRT	3	5.8	10	Flexible, variable speed control, free yaw, tail-furl, EDC01 event
Test17	SWRT	3	5.8	10	Flexible, variable speed control, free yaw, tail-furl, turbulence

Primary Input File

FAST uses a primary input file to describe the wind turbine operating parameters and basic geometry. However, the blade, tower, furling, and aerodynamic parameters and wind-time histories are read from separate files. Additionally, input parameters related to FAST linearization and parameters only necessary for creation of ADAMS datasets are read in from separate files (see Figure 29). Descriptions of the individual inputs in the various files are provided below. Output files are discussed in the Output Files chapter.

The primary input file has a default name of *primary.fst*, which FAST will try to open if you do not specify a file name on the command line. If you want to use different names for different cases, you can specify a file with a different name on the command line. Files with spaces in their paths or names must be delimited by quotes. File names are limited to 99 characters and may include absolute or relative paths.

The parameter input files have a simple text format that can be read and modified by any text editor. Most lines in the input file are divided into three sections: value(s), variable name(s), and description. For lines that require more than one value, separate them with spaces, tabs, or commas. Anything past the last value

on the line is treated as a comment. Values for string variables must be delimited with a pair of apostrophes or double quotes. Logical flags must be unquoted strings that start with *t* or *T* for True and *f* or *F* for False. The Variable-Name section contains the variable name used internally by the program and in references for other parameters. The Description section of the line contains a brief description of the parameter as a reminder to the user of its purpose. This section also contains the physical units of the numerical value, where appropriate. A sample line from the input file for input parameter TMax, divided into its sections is shown below:

```
20.0 TMax - Total run time (s)
```

Note that there are no blank lines in the input files. The program reads each line in sequential order. You should never add or delete any lines except in the various sections that allow it. The tower, blade and AeroDyn input files have sections where you enter one line per input station analysis node. The primary FAST input file has a list of output parameters at the end of the file that can be as long as you like.

Note also that lines containing section or file titles may be altered to suit the user. FAST ignores these lines when it reads the input, but these lines should not

be deleted for the same reasons mentioned in the previous paragraph.

Some parameters do not apply to two-bladed turbines, and others do not apply to three-bladed turbines. FAST treats these as comments. Any text may be used on the unused lines, or they may even be blank, but they must exist. The sample input files identify such parameters.

Several other files are read for additional parameters. One of the parameters in the primary file is the name of the tower file (TwrFile). There are three other parameters designating the names of the three blade input files (BlfFile_i). If you want to use identical properties for all blades, you may specify the same

name three times. One more parameter in the primary input file identifies the name of the file containing additional model properties for a furling turbine (FurlFile), another specifies the aerodynamic noise input file (NoiseFile), and another identifies the name of the AeroDyn input file (ADFile). Additionally, the name of the input file relating to a FAST linearization analysis (LinFile) and the name of the file containing ADAMS-specific data input (ADAMSFile) are further parameters in the primary input file.

Table 8 lists the input parameters for the primary input file.

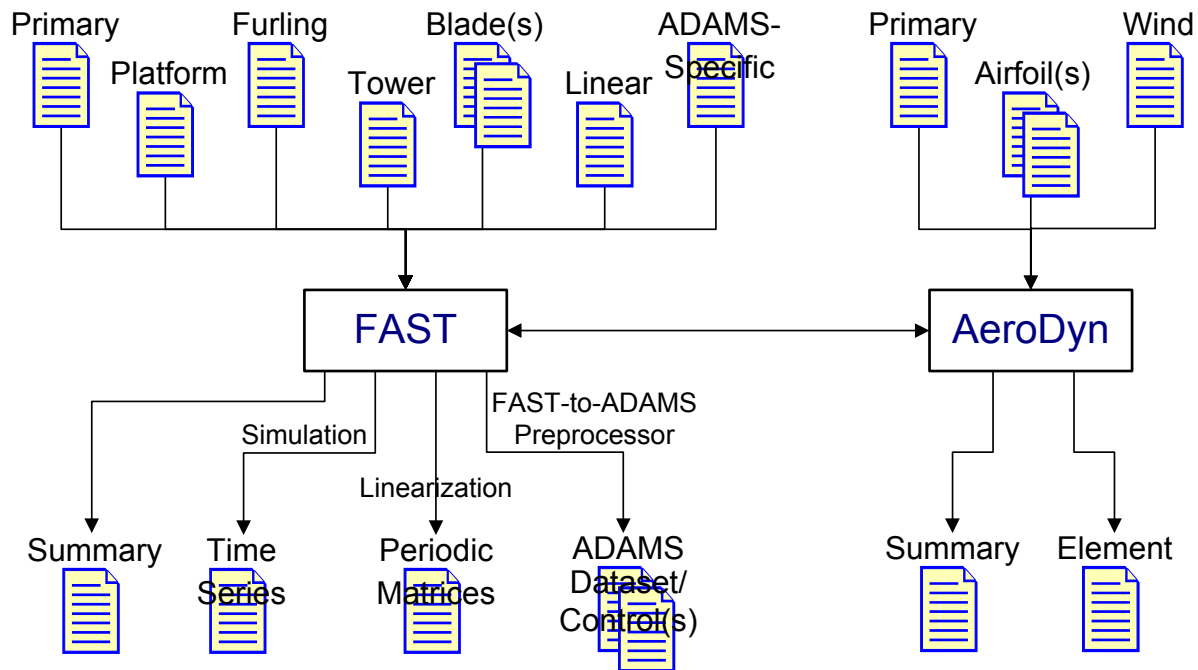

Figure 29. Input and Output Files.

Tower Input File

In the tower file, there is a table for the tower characteristics, which requires several columns of data in the Distributed Tower Properties section of the input file. Only the first four columns are used to characterize the FAST model. The last six columns are used only for creating ADAMS datasets using the FAST-to-ADAMS preprocessor feature of FAST. You need to enter only one line if the tower is uniform. You must specify a zero for the location of this single station. If you model a non-uniform tower, you must specify at least two stations; the first must be at the 0 location and the last must have a location of 1 (for 100% of the flexible height of the tower). FAST will

linearly interpolate these data to the centers of the equally spaced segments, which are the analysis nodes. There are TwrNodes segments or analysis nodes. To get the most accurate results from these properties, include data points for the analysis nodes in the input table.

Table 9 lists the input parameters for the tower input file. FAST reads this file even if you requested no tower DOFs.

Blade Input Files

In the blade input files, there are tables of blade characteristics. There are several columns of data in the Distributed Blade Properties section, each of which must be separated from the other by a space, tab, or

comma. Only the first six columns are used to characterize the FAST model. The last 11 columns are used only for creating ADAMS datasets using the FAST-to-ADAMS preprocessor feature of FAST. You need to enter only one line if the blade is uniform. You must specify a zero for the location of this single station. If you model non-uniform blades, you must specify at least two stations; the first must be at the zero location and the last must have a location of 1 (for 100% span). FAST will linearly interpolate these data to the analysis nodes specified in the AeroDyn input file. There are **BldNodes** segments or analysis nodes. To get the most accurate results from these properties, include data points for the analysis nodes in the input table.

Table 10 lists the input parameters for the blade input files. FAST reads this file even if you requested no blade DOFs.

AeroDyn Input Files

Table 11 lists the input parameters for the primary AeroDyn input file. AeroDyn also uses other input files. The current version of AeroDyn accommodates two types of wind files. One type specifies hub-height wind data that also includes wind shears and gusts. You can use IECWind (14) or WindMaker (15) to generate these files for standard IEC wind conditions. You can also fabricate these simple text files from scratch or even use field-test data. The other type of wind file contains full-field wind data in a binary form. TurbSim (16), SNwind (17), or SNLWIND-3D (18) can generate these files. They contain two-dimensional grids of three-component winds that march past the turbine at a mean wind speed. AeroDyn also reads one or more files containing airfoil data.

Please see the AeroDyn user's guide (1) for additional details on these files. FAST reads these files even if you disabled aerodynamic calculations.

Platform Input File

Table 12 lists the input parameters for the platform input data file. This file contains inputs related to the support platform configuration, motions, and loading.

FAST only reads the platform input file if **PtfmModel** from the primary input file is nonzero. In FAST v6.0, all nonzero **PtfmModel** options will work the same way by reading in the **PtfmFile** described in Table 12. In future versions, the format of this file will depend on which **PtfmModel** option is selected.

Furling Input File

Table 13 lists the input parameters for the furling input file. The inputs pertain to the lateral offset and skew angle of the rotor shaft, rotor-furling, tail-furling, and tail inertia and aerodynamics. If the turbine you want to model contains any of these characteristics, you must assemble the furling input file even if your turbine does not “furl” in the common sense of the word. For example, if the turbine you want to model contains a tail, you must assemble the furling input file regardless of whether or not your tail, or rotor, actively furls about the yawing-portion of the structure atop the tower.

It is clear that the inputs available in the furling input file define the core configuration of the turbine, just like those available in the primary input file. The reason we separated the parameters between the two input files is that the parameters available in the furling input are unique to small wind turbines. The challenge in defining the unique configurations of small wind turbines relative to the configurations of conventional machines is clearly demonstrated by the contents of the furling input file. Who said small wind turbines are easier to design than large wind turbines?

The furling input file is organized into sections similar to those available in the primary input file. This supports the notion that the furling file is simply a continuation and expansion of the core configuration-definition designations available in the primary file.

FAST only reads the furling input file if the model is designated as a furling machine (when **Furling** is set to True).

ADAMS-Specific Input File

Table 14 lists the input parameters for the ADAMS-specific-input data file. This file contains inputs related to the blade pitch actuators, graphical output capabilities, and other ADAMS-specific functionalities.

FAST does not read this file if ADAMS datasets are not generated (when **ADAMSPrep** is set to 1).

Linearization Control-Input File

Table 15 lists the input parameters relating to a FAST linearization analysis. FAST only reads in this file when performing a linearization analysis (when **AnalMode** is set to 2).

Table 8. Primary-Input-File Parameters.

Simulation Control

Echo	Setting this flag to True will cause FAST to echo input values as it reads them. It writes the data to the file <i>echo.out</i> . This is a useful tool to debug problems with your input files. For normal operation, set this parameter to False. (flag)
ADAMSPrep	This switch determines whether or not the ADAMS preprocessor is enabled. Setting ADAMSPrep to 1 disables the ADAMS preprocessor and causes FAST to run its simulation as normal. A setting of 2 turns on the ADAMS preprocessor and turns off FAST; when FAST is run, the ADAMS datasets are created and FAST stops without performing a simulation. A setting of 3 enables both FAST and the ADAMS preprocessor; when FAST is run, the ADAMS datasets are created and FAST proceeds to run its simulation. Using values other than 1, 2, or 3 will cause FAST to abort. ADAMSPrep must be 1 when FAST is interfaced with Simulink. (switch)
AnalMode	This switch determines whether to perform a time-marching analysis (simulation) or a linearization analysis (i.e., AnalMode stands for the analysis mode). A setting of 1 indicates a time-marching analysis. To perform a linearization analysis, set AnalMode to 2. Using values other than 1 or 2 will cause FAST to abort. AnalMode must be 1 when FAST is interfaced with Simulink. This input is not used in the FAST-to-ADAMS preprocessor. (switch)
NumBl	This is the number of blades on the rotor. Valid values are 2 and 3. (-)
TMax	The overall simulation runtime. For time-marching simulations, the simulation stops when TMax is reached. When computing a steady state solution during a linearization analysis, the iteration stops and FAST aborts if the solution has not converged by the time TMax is reached. (sec)
DT	This is the time step for the constant-step-size numerical-integration scheme that is used by FAST. For ADAMS datasets extracted from FAST, DT is used to specify the maximum step size the integrator is allowed to take in the variable-step-size numerical-integration scheme that is used by ADAMS. You should be careful to choose an appropriate value for DT because if DT is too small or too large, the numerical solution will become unstable. Whenever you make changes to the configuration of your model, you should experiment with different values for DT and choose the largest value that does not affect your results. (sec)

Turbine Control

YCMODE	This is the yaw-control-mode switch for user-defined nacelle yaw control. Setting it to 0 disables user-defined yaw control. Setting it to 1 causes FAST to call a user-written routine called UserYawCont() at every time step past TYCON. We supply a dummy routine in the software folder to help you write your own. Setting YCMODE to 2 causes FAST to accept yaw position and rate demands externally from Simulink. The simple yaw maneuvers described below override the control setting determined by the user-supplied yaw controllers. Please see the Controls chapter for further details. YCMODE must be 0 during a linearization analysis and must not be 2 unless FAST is interfaced with Simulink. Using values other than 0, 1, or 2 will cause FAST to abort. (switch)
TYCON	The time to enable active nacelle yaw control. This parameter is used only if YCMODE is set to a non-zero value. TYCON must not be negative and must equal zero when YCMODE is 2. Please see the Controls chapter for further details. (sec)
PCMODE	This is the pitch-control-mode switch for user-defined pitch control. Setting it to 0 disables user-defined pitch control. Setting it to 1 causes FAST to call a user-written routine called PitchCntrl() at every time step past TPCON. A real pitch-control routine created by Craig Hansen is linked with FAST, but we supply a dummy routine in the software folder to help you write your own. Setting PCMODE to 2 causes FAST to accept pitch demands externally from Simulink. The simple pitch maneuvers described below override the control setting determined by the user-supplied pitch controllers. Please see the Controls chapter for further details. PCMODE must be 0 during a linearization analysis and must not be 2 unless FAST is interfaced with Simulink. Using values other than 0, 1, or 2 will cause FAST to abort. (switch)

Table 8. Primary-Input-File Parameters (continued).

Turbine Control (continued)

TPCOn	The time to enable active pitch control. This parameter is used only if PCMode is set to a non-zero value. TPCOn must not be negative and must equal zero when PCMode is 2. Please see the Controls chapter for further details. (sec)
VSContrl	This switch determines whether the generator torque is actively controlled for variable speed machines. The generator DOF flag, GenDOF, must be enabled to use this feature. Setting VSContrl to 0 will cause FAST to use one of the generator models defined by GenModel below to determine the generator torque. A setting of 1 for VSContrl will invoke a simple variable-speed model that uses the next four input parameters to determine the generator torque. Setting VSContrl to 2 will enable a user-written routine, UserVSCont(), to determine the generator torque. A sample routine is included in the file <i>UserVSCont_KP.f90</i> and a dummy placeholder is available (and commented out) in <i>UserSubs.f90</i> . Setting VSContrl to 3 causes FAST to accept generator torque and electrical power demands externally from Simulink. VSContrl must not be 3 unless FAST is interfaced with Simulink. Using values other than 0, 1, 2, or 3 will cause FAST to abort. Please see the Controls chapter for further details. (switch)
VS_RtGnSp	The simple variable-speed control changes from the Region 2½ (linear torque versus speed transition) to Region 3 (constant-torque control) at this generator speed (HSS speed). See Figure 22 for details. This value must not be less than zero, but it is ignored if VSContrl is not equal to 1. (rpm)
VS_RtTq	This is the constant (or rated) torque applied to the HSS by the generator in Region 3 for the simple variable-speed controller. See Figure 22 for details. This value must not be less than zero, but it is ignored if VSContrl is not equal to 1. (N·m)
VS_Rgn2K	When in Region 2 for the simple variable-speed controller, the generator speed is squared and multiplied by VS_Rgn2K to compute the generator torque to apply to the HSS. See Figure 22 for details. This value must not be less than zero, but it is ignored if VSContrl is not equal to 1. (N·m/rpm ²)
VS_SIPc	This is the rated generator slip percentage in the linear torque versus speed transition Region 2½ for the simple variable-speed controller. Similar to the simple induction generator input parameter SIG_SIPc, input VS_SIPc should be computed as the difference between the rated and the equivalent synchronous generator speed, divided by the equivalent synchronous speed, and then converted to percent. See Figure 22 for details. This value must be greater than zero, but it is ignored if VSContrl is not equal to 1. (%)
GenModel	This switch determines which generator model is used when GenDOF is enabled and VSContrl is set to 0. Setting it to 1 enables the simple-induction-generator model, whose parameters are defined in the Simple-Induction-Generator section below. Setting it to 2 enables the Thevenin-equivalent induction-generator model, whose parameters are defined in the Thevenin-Equivalent-Induction-Generator section below. Setting it to 3 will cause FAST to call the user-written subroutine, UserGen(). A UserGen() routine (found in <i>UserVSCont_KP.f90</i>), which calls routine UserVSCont() as if VSContrl was set to 2, is normally linked with the program and a dummy placeholder of UserGen() is also available (and commented out) in source file <i>UserSubs.f90</i> . In order to define your own generator model, you will need to write your own routine to replace it to use this option. Using values other than 1, 2, or 3 will cause FAST to abort. (switch)
GenTiStr	This flag determines whether the generator is brought online at a specific time (TimGenOn) or a specific generator speed (SpGenOn). To use this feature, you must enable the generator DOF (GenDOF). GenTiStr must be True and TimGenOn must be 0.0 during a linearization analysis (AnalMod = 2) or when VSContrl is set to 3. (flag)
GenTiStp	This flag determines whether the generator is taken offline at a specific time (TimGenOf) or when power falls to zero. To use this feature, you must enable the generator DOF (GenDOF). GenTiStp must be True and TimGenOf must be greater than TMax during a linearization analysis (AnalMod = 2) or when VSContrl is set to 3. (flag)
SpGenOn	If GenTiStr is False, the generator will switch on and stay on once the HSS speed reaches SpGenOn. This is used to do a speed startup of the generator. It applies to all generator models, including user-defined and variable-speed control. (rpm)

Table 8. Primary-Input-File Parameters (continued).

Turbine Control (continued)

TimGenOn	If GenTiStr is True, the generator will switch on at time TimGenOn. This is used to do a timed startup of the generator. It applies to all generator models, including user-defined and variable-speed control. GenTiStr must be True and TimGenOn must be 0.0 during a linearization analysis (AnalMod = 2) or when VSContrl is set to 3. (sec)
TimGenOf	This parameter determines the time to turn off the generator when GenTiStp is True. This can be used for a shutdown maneuver or to simulate a loss of grid. This value is used whether you do a timed or speed-based startup. Normally, you won't simulate a startup and a loss of grid (or shutdown) in the same run. In those cases, you will probably want to set this value to be greater than TMax. When you do want to use TimGenOf, you will probably want to enable GenTiStr and set TimGenOn to 0. TimGenOf must be greater than or equal to TimGenOn if GenTiStr is enabled. This parameter is not used if GenTiStp is False. In that case, the generator is taken offline when the power drops to zero. GenTiStp must be True and TimGenOf must be greater than TMax during a linearization analysis (AnalMod = 2) or when VSContrl is set to 3. (sec)
HSSBrMode	This switch determines which HSS brake model is used when GenDOF is enabled. Setting it to 1 enables the simple built-in HSS brake torque with a linear ramp-up from zero to HSSBrTqF over time HSSBrDT. Setting it to 2 causes FAST to call a user-written routine called UserHSSBr() at every time step past THSSBrDp. We supply a dummy routine in the software folder to help you write your own. Please see the Controls chapter for further details. Using values other than 1 or 2 will cause FAST to abort. (switch)
THSSBrDp	At this time, the HSS brake will be deployed. In the simple model (HSSBrMode = 1), the braking torque will start its linear ramp to full torque, which happens after HSSBrDT seconds. In the user-defined model (HSSBrMode = 2), routine UserHSSBr() determines the fraction of full braking torque after deployment. You will probably want to turn the generator off a short time before this with TimGenOf before starting the HSS brake maneuver. THSSBrDp must be greater than TMax during a linearization analysis (AnalMod = 2) or when FAST is interfaced with Simulink. (sec)
TiDynBrk	The dynamic generator brake engages at this time. This input is CURRENTLY IGNORED since logic for the dynamic generator brake is not currently coded in FAST. TiDynBrk must be greater than TMax during a linearization analysis. (sec)
TTpBrDp _i	The ⁱ th tip brake will start to deploy at this time. The drag constant for this brake will start to ramp up from TDrConN to TDrConD. You can specify different times for different brakes to simulate such conditions as one brake accidentally deploying or a situation in which one brake fails to deploy when commanded to do so. TTpBrDp _i must be greater than TMax during a linearization analysis. Only the first two values are used for two-bladed turbines. (sec)
TBDepISp _i	The ⁱ th tip brake will start to deploy when the rotor speed reaches TBDepISp _i . Up to this point, the drag constant for the tip brake is TDrConN. Once the tip brake starts to deploy, it will take TpBrDT seconds to reach full deployment, where it will remain deployed and using TDrConD for the drag constant. During the TpBrDT second deployment, the drag constant for the tip brake will have an s-shaped ramp from TDrConN to TDrConD. TBDepISp _i must be much greater than RotSpeed during a linearization analysis. Only the first two values are used for two-bladed turbines. (rpm)
TYawManS	With or without yaw control or the yaw DOF enabled, after time TYawManS, the nacelle will yaw to NacYawF using a linear ramp from its current value at TYawManS until TYawManE. If yaw control is enabled when YCMode is not 0, the yaw commands determined from inputs TYawManS, TYawManE, and NacYawF override whatever commands come from the yaw controller. Also, the yaw commands determined from inputs TYawManS, TYawManE, and NacYawF pass through FAST's built-in second-order actuator model if the yaw DOF is enabled when YawDOF is set to True. You can use TYawManS and TYawManE to simulate a yaw for startup, shutdown, or runaway yaw event. For a fixed-yaw simulation, set YawDOF to False, YCMode to 0, TYawManS greater than TMax, and NacYaw to the fixed nacelle yaw angle. TYawManS must be greater than TMax during a linearization analysis. (sec)
TYawManE	The nacelle yaw command will hold at a constant setting of NacYawF from this time until the end of the run. TYawManE must be set larger or equal to TYawManS. (sec)

Table 8. Primary-Input-File Parameters (continued).

Turbine Control (concluded)

NacYawF	The nacelle yaw command will hold at a constant setting of NacYawF from TYawManE until the end of the run. (degrees)
TPitManS _i	With or without pitch control enabled, after time TPitManS _i , the i th blade will pitch to BIPitchF _i using a linear ramp from its current value at TPitManS _i until TPitManE _i . If pitch control is enabled when PCMode is not 0, the pitch commands determined from inputs TPitManS _i , TPitManE _i , and BIPitchF _i override whatever commands come from the pitch controller. You can use TPitManS _i and TPitManE _i to simulate a pitch for startup, shutdown, or runaway pitch event. By setting one blade different from the other(s), you can simulate a fault condition in which one blade unexpectedly pitches or fails to pitch. For a constant-pitch simulation, set PCMode to 0, TPitManS _i greater than TMax, and BIPitch _i to the fixed blade pitch angles. TPitManS _i must be greater than TMax during a linearization analysis. Only the first two values are used for two-bladed turbines. (sec)
TPitManE _i	The i th blade will hold at a constant a setting of BIPitchF _i from this time until the end of the run. TPitManE _i must be set larger or equal to TPitManS _i . Only the first two values are used for two-bladed turbines. (sec)
BIPitch _i	When PCMode is 0 during a time-marching analysis or if TrimCase is 1 or 2 while computing a steady state solution during a linearization analysis, the i th blade will hold at a constant setting of BIPitch _i until TPitManS _i . If PCMode is not 0 or if TrimCase is 3 while computing a steady state solution during a linearization analysis, BIPitch _i is the initial pitch. The pitch angle is relative to the chord line at the point of zero aerodynamic twist and is positive towards feather (leading edge upwind). These values must be greater than -180 and less than or equal to 180 degrees. Only the first two values are used for two-bladed turbines. (deg)
BIPitchF _i	The i th blade will hold at a constant setting of BIPitchF _i from TPitManE _i until the end of the run. This is relative to the chord line at the point of zero aerodynamic twist and is positive towards feather (leading edge upwind). Only the first two values are used for two-bladed turbines. (deg)

Environmental Conditions

Gravity The gravitational acceleration constant. (m/sec²)

Feature Flags*

FlapDOF1	The first flapwise blade-bending mode will be enabled when this flag is True. When enabled, you should ensure that the corresponding mode shape specified in the blade input files is accurate. For ADAMS datasets extracted from FAST, this flag is used to enable or disable blade flexibility and its value must be identical to that of EdgeDOF. (flag)
FlapDOF2	The second flapwise blade-bending mode will be enabled when this flag is True. It is possible to enable the second mode without enabling the first mode, but it should be done only for research purposes. When enabled, you should ensure that the corresponding mode shape specified in the blade input files is accurate. The value of this input does not effect the creation of ADAMS datasets. (flag)
EdgeDOF	The first edgewise blade-bending mode will be enabled when this flag is True. When enabled, you should ensure that the corresponding mode shape specified in the blade input files is accurate. For ADAMS datasets extracted from FAST, this flag is used to enable or disable blade flexibility and its value must be identical to that of FlapDOF1. (flag)
TeetDOF	This flag enables rotor teetering when set to True. If this option is disabled, teeter can be set to any fixed angle. This flag is ignored for three-bladed turbines. (flag)

* You must enable at least one DOF during a linearization analysis (AnalMode set to 2). During a time-marching analysis (AnalMode set to 1), there is no restriction.

Table 8. Primary-Input-File Parameters (continued).

Feature Flags (concluded)

DrTrDOF	If set to True, this flag will enable torsional flexibility of the drivetrain. This models the drivetrain between the generator and rotor as a lumped torsion spring and damper. (flag)
GenDOF	The generator DOF will be enabled when this flag is True. This allows use of the various variable-speed control schemes and generator models during a time-marching analysis or a trim solution during a linearization analysis. If False, the HSS will rotate at a fixed rate ($\text{RotSpeed} \cdot \text{GBRatio}$). (flag)
YawDOF	When set to True, this flag enables the nacelle yaw DOF. The initial nacelle yaw angle is specified with <code>NacYaw</code> . If YawDOF is disabled, the yaw angle will be fixed at <code>NacYaw</code> . (flag)
TwFADOF1	The first tower fore-aft bending mode will be enabled when this variable is set to True. When enabled, you should ensure that the corresponding mode shape specified in the tower input file is accurate. For ADAMS datasets extracted from FAST, this flag is used to enable or disable tower flexibility and its value must be identical to that of <code>TwSSDOF1</code> . (flag)
TwFADOF2	The second tower fore-aft bending mode will be enabled when this variable is set to True. Except for research purposes, this flag should be set to True only if <code>TwFADOF1</code> is True. When enabled, you should ensure that the corresponding mode shape specified in the tower input file is accurate. The value of this input does not effect the creation of ADAMS datasets. (flag)
TwSSDOF1	The first tower side-to-side bending mode will be enabled when this variable is set to True. When enabled, you should ensure that the corresponding mode shape specified in the tower input file is accurate. For ADAMS datasets extracted from FAST, this flag is used to enable or disable tower flexibility and its value must be identical to that of <code>TwFADOF1</code> . (flag)
TwSSDOF2	The second tower side-to-side bending mode will be enabled when this variable is set to True. Except for research purposes, this flag should be set to True only if <code>TwSSDOF1</code> is True. When enabled, you should ensure that the corresponding mode shape specified in the tower input file is accurate. The value of this input does not effect the creation of ADAMS datasets. (flag)
CompAero	This flag determines whether aerodynamic loads will be computed using the AeroDyn aerodynamic modules. If False, the simulation will occur in a vacuum (no airloads). AeroDyn input properties are specified in the <code>ADFile</code> (see input below). The <code>ADFile</code> must exist even if <code>CompAero</code> is False, since <code>RNodes</code> determines the location of the structural analysis points. (flag)
CompNoise	A series of semi-empirical aeroacoustic noise prediction algorithms has been incorporated into FAST by Pat Moriarty of NREL/NWTC. The algorithms predict six different forms of aerodynamically produced noise including turbulent inflow, turbulent boundary layer trailing edge, separating flow, laminar boundary layer vortex shedding, trailing edge bluntness vortex shedding, and tip vortex formation. These noise sources are then superimposed to calculate and output the total aerocoustic signature of an operating wind turbine. CURRENTLY, THE NOISE PREDICTION INTERFACE IS NOT DOCUMENTED IN THIS GUIDE (except as it effects the primary-input-file). Details on the contents and validation of the aeroacoustic noise prediction models are provided in [19]. Questions related to the noise prediction models and interface should be directed to Pat Moriarty, preferably at night or on weekends ☺. The <code>CompNoise</code> flag determines whether aerodynamic noise will be computed. Aerodynamic noise input properties are specified in the <code>NoiseFile</code> (see input below). <code>CompAero</code> must be enabled if <code>CompNoise</code> is enabled. <code>CompNoise</code> must be False during a linearization analysis. The value of this input does not effect the creation of ADAMS datasets since the aeroacoustic algorithms are not linked to ADAMS. (flag)

Table 8. Primary-Input-File Parameters (continued).

Initial Conditions

OoPDefl	This is the initial, out-of-plane, blade-tip displacement. The same value is used for all blades. Note that by specifying values for initial conditions close to the steady-state conditions, the numerical solution technique will reach trimmed conditions faster. It is positive downwind. It is possible to specify combinations of tip displacements that are not meaningful for the blade structural pretwist distribution and the DOFs that are enabled. If so, FAST will issue a warning message and choose meaningful values for you. The value of OoPDefl must be zero (no initial deflection) when creating ADAMS datasets or when FAST is interfaced with Simulink. (m)
IPDefl	This is the initial, in-plane, blade-tip displacement. The same value is used for all blades. Note that by specifying values for initial conditions close to the steady-state conditions, the numerical solution technique will reach “trimmed conditions” faster. It is positive clockwise when looking upwind. It is possible to specify combinations of tip displacements that are not meaningful for the blade structural pretwist distribution and the DOFs that are enabled. If so, FAST will issue a warning message and choose meaningful values for you. The value of IPDefl must be zero (no initial deflection) when creating ADAMS datasets or when FAST is interfaced with Simulink. (m)
TeetDefl	This is the initial or fixed teeter angle. It is positive when Blade 1 is deflected downwind of the rotor. This value must be greater than -180 and less than or equal to 180 degrees and must be zero when creating ADAMS datasets. This parameter is ignored for three-bladed turbines. (deg)
Azimuth	This is the initial azimuth angle for Blade 1. Please note that for three-bladed rotors, blade 3 is ahead of blade 2, which is ahead of blade 1, so that the order of blades passing through a given azimuth is 3-2-1-repeat. Azimuth works in conjunction with AzimB1Up, which is input in the Turbine Configuration section that follows. This value must be greater or equal to 0 and less than 360 degrees. (deg)
RotSpeed	This is the initial angular speed of the rotor. During a linearization analysis, this is also the desired azimuth-average rotor speed for a trim solution. This value must not be negative. The turbine rotates clockwise when looking downwind. (rpm)
NacYaw	This is the initial or fixed nacelle yaw angle. It is positive counterclockwise when looking down on the turbine. This value must be greater than -180 and less than or equal to 180 degrees. (deg)
TTDspFA	This is the initial fore-aft tower-top displacement. It is positive downwind. The value of TTDspFA must be zero (no initial deflection) when creating ADAMS datasets or when FAST is interfaced with Simulink. (m)
TTDspSS	This is the initial side-to-side tower-top displacement. It is positive to the right when looking upwind. The value of TTDspSS must be zero (no initial deflection) when creating ADAMS datasets or when FAST is interfaced with Simulink. (m)

Turbine Configuration

TipRad	The blade-tip radius is the distance from the apex of the cone of rotation to the blade tip along the pitch axis instead of the perpendicular distance from the axis of rotation. See Figure 14(a) and Figure 16. This value must be greater than zero. (m)
HubRad	The hub radius is the distance from the apex of the cone of rotation to the blade root along the pitch axis instead of the perpendicular distance from the axis of rotation. The blade root loads are defined at this radial span location. See Figure 14(b) and Figure 16. This value must be greater than or equal to zero and less than TipRad. (m)
PSPnEIN	This is the blade element number corresponding to the innermost blade element that is part of the pitchable portion of the blade for partial-span pitch control. The pitch of all the blade elements from PSPnEIN to BidNodes are controlled by the BIPitch(:) array, whereas all the blade elements from 1 to (PSPnEIN - 1) are not pitchable. Note that PSPnEIN is CURRENTLY IGNORED by FAST; that is, the logic for partial-span pitch control has not yet been codified in FAST. This value must be an integer between 1 and BidNodes (inclusive). (-)
UndSling	The undersling is the distance from the teeter pin to the apex of the cone of rotation. It is positive upwind. This parameter is ignored for three-bladed turbines. See Figure 14(b). (m)
HubCM	This is the distance from the rotor apex to the hub mass center. It is positive downwind. See Figure 14(b) and Figure 16. (m)

Table 8. Primary-Input-File Parameters (continued).

Turbine Configuration (concluded)

OverHang	This is the distance along the rotor shaft from the y_n/z_n -plane to the teeter pin for two-bladed turbines or from the y_n/z_n -plane to the rotor apex for three-bladed turbines. It is positive downwind, so use a negative number for upwind turbines. For turbines with rotor-furl, this distance defines the configuration at a furl angle of zero. See Figure 14(a), Figure 16, and Figure 18. (m)
NacCMxn	This is the downwind distance to the nacelle mass center (reference input NacMass) from the top of the tower, measured parallel to the x_n -axis. It is positive downwind. See Figure 14(a) and Figure 16. (m)
NacCMyn	This is the lateral distance to the nacelle mass center (reference input NacMass) from the top of the tower, measured parallel to the y_n -axis. It is positive to the left when looking downwind or positive into the page of Figure 14(a) and Figure 16. (m)
NacCMzn	This is the vertical distance to the nacelle mass center (reference input NacMass) from the top of the tower, measured parallel to the z_n -axis. It is positive upward when looking downwind. See Figure 14(a) and Figure 16. (m)
TowerHt	The tower height is the distance from ground level [onshore] or mean sea level [offshore] to the top of the tower and yaw bearing. This value must be greater than zero. See Figure 14(a), Figure 16, and Figure 20. (m)
Twr2Shft	This is the vertical distance from the top of the tower and yaw bearing to the intersection of the rotor shaft axis and the y_n/z_n -plane. The distance is measured parallel to the z_n -axis. See Figure 14(a), Figure 16, and Figure 18. The combination of TipRad, TowerHt, Twr2Shft, OverHang, and ShftTilt must ensure that the blade tip does not hit the ground. This value also cannot be negative. For turbines with rotor-furl, this distance defines the configuration at a furl angle of zero. (m)
TwrRBHt	The tower rigid base height is the distance from tower base to the beginning of the flexible portion of the tower. The tower base loads are defined at this elevation. This value must be greater or equal to zero and less than TowerHt + TwrDraft. (m)
ShftTilt	This is the tilt angle of the rotor shaft from the nominally horizontal plane. Positive tilt means that the downwind end of the shaft is the highest. This value must be between -90 and 90 degrees. Upwind turbines have negative tilt for improved tower clearance. For turbines with rotor-furl, this angle defines the configuration at a furl angle of zero. See Figure 14(a), Figure 16, and Figure 18. (deg)
Delta3	This teeter pin orientation angle allows coupling between the flapping due to teeter and blade pitch. A positive value means that the blade that teeters downwind has a positive change in pitch (leading edge upwind). See Figure 15 and the discussion on page 13 for details. This value must be between -90 and 90 degrees (exclusive) and is ignored for three-bladed turbines. (deg)
PreCone _i	The coning angle for the i^{th} blade is positive downwind for upwind and downwind rotors. See Figure 14(a) and Figure 16. These values must be greater than -180 and less than or equal to 180 degrees. Only the first two values are used for two-bladed turbines. (deg)
AzimB1Up	All input and output azimuth values are measured with respect to this number. If this value is 0 and the rotor azimuth is 180 degrees, then Blade 1 is pointing down. Please keep in mind that the rotor rotates clockwise when looking downwind, so an azimuth value of 90 degrees means Blade 1 is pointing to the right (looking downwind) when AzimB1Up is 0. If AzimB1Up is 270 degrees and Azimuth is 0 degrees, then Blade 1 is to the right when looking downwind. Also note that for three-bladed rotors, blade 3 is ahead of blade 2, which is ahead of blade 1, so that the order of blades passing through a given azimuth is 3-2-1-repeat. (deg)

Table 8. Primary-Input-File Parameters (continued).

Mass and Inertia

YawBrMass	This is the mass of the yaw bearing. Its center is located at the top of the tower, at the origin of the tower-top/base-plate and nacelle/yaw coordinate systems. This value must not be negative. (kg)
NacMass	This is the mass of the nacelle. The center of the nacelle mass is located at the point specified by inputs NacCMxn, NacCMyn, and NacCMzn relative to the tower-top. It includes everything atop the tower excluding the rotor (blades, hub, and tip brakes), yaw bearing, and systems that furl (tail boom, tail fin, and structure furling with the rotor). This value must not be negative. (kg)
HubMass	This is the mass of the hub. Its center is located a distance of HubCM from the rotor apex. This value must not be negative. (kg)
TipMass _i	This is the tip-brake mass for the i th blade. This value must not be negative. Only the first two values are used for two-bladed turbines. (kg)
NacYIner	This is the nacelle moment of inertia about the yaw axis. It includes all mass contained in NacMass. This value must be greater than NacMass*(NacCMxn ² + NacCMyn ²). (kg·m ²)
GenIner	This is the moment of inertia of the high-speed portion of the drivetrain including the gearbox, HSS, and generator. If torsional flexibility of the drivetrain is enabled, the compliance is between the inertia of the rotor and this inertia. This value will be multiplied by the square of the gear ratio to map it to the low-speed reference frame. This value must not be negative. (kg·m ²)
HubIner	The hub moment of inertia is measured about the teeter axis for two-bladed turbines or about the rotor shaft axis for three-bladed turbines. For two-bladed turbines, it includes those parts that teeter, except for the blades and tip brakes, and must be greater than HubMass*(UndSling – HubCM) ² . For three-bladed turbines, it excludes the blades and tip brakes and must not be negative. (kg·m ²)

Drivetrain

GBoxEff	The gearbox efficiency is the ratio of the output shaft power to the input shaft power. Enter it as a percentage from 0 to 100. The value of GboxEff must be 100 (no mechanical losses) when creating ADAMS datasets. (%)
GenEff	The generator efficiency is the ratio of its output power to its input power. It is used by the simple-induction-generator model (GenModel = 1) to obtain the electrical power from the mechanical power, which is a product of the generator torque and HSS speed. It is also used by the simple variable-speed, generator torque controller (VSContrl = 1) in the same manor. Enter it as a percentage from 0 to 100. GenEff is ignored by the Thevenin-equivalent induction-generator model (GenModel = 2), which incorporates a more complex expression for the electrical power based on the input circuit resistances. The value of GenEff is passed to UserGen() and UserVSCont() for the user-defined generator model (GenModel = 3) and user-defined variable-speed, generator torque controller (VSContrl = 2) respectively, but the user-defined models allow for the flexibility of implementing any relationship between input and output power. (%)
GBRatio	This is the ratio of the HSS speed to the LSS speed. This value must be greater than zero and should be 1.0 for a direct-drive turbine. (-)
GBRevers	Set this value to True if the direction of rotation of the LSS is opposite that of the HSS. GBRevers must be set to False when creating ADAMS datasets. (flag)
HSSBrTqF	This maximum mechanical brake torque value is applied to the HSS end of the drivetrain compliance. This value must not be negative. It is used by both the simple (HSSBrMode = 1) and user-defined (HSSBrMode = 2) HSS brake models. (N·m)
HSSBrDT	For the simple HSS brake model (HSSBrMode = 1), this is the amount of time it takes the HSS brake to reach full torque once it is applied. The ramp from off to full torque is linear. This value must not be negative and is unused when HSSBrMode is set to 2. (sec)
DynBrkFi	This is name of a file containing a curve of mechanical generator torques versus HSS speeds defining the dynamic generator brake characteristics. The name may optionally include an absolute or relative path. This file name must contain fewer than 100 characters and must be enclosed in apostrophes or double quotes. This input is CURRENTLY IGNORED since logic for the dynamic generator brake is not currently coded in FAST. (-)

Table 8. Primary-Input-File Parameters (continued).

Drivetrain (concluded)

DTTorSpr	The equivalent drive-train torsional spring constant includes compliance in the LSS, the gearbox, and the HSS. This value must not be negative. (N·m/rad)
DTTorDmp	The equivalent drive-train torsional damping constant includes compliance in the LSS, the gearbox, and the HSS. This value must not be negative. (N·m/sec)

Simple Induction Generator

SIG_SIPc	The rated generator slip percentage is the difference between the rated and the synchronous generator speed divided by the synchronous generator speed, and then converted to percent. See Figure 12 for details. This value must be greater than zero, but it is ignored if GenModel is not equal to 1 or VSContrl is not equal to 0. (%)
SIG_SySp	This is the synchronous or zero-torque generator speed. See Figure 12 for details. This value must be greater than zero, but it is ignored if GenModel is not equal to 1 or VSContrl is not equal to 0. (rpm)
SIG_RtTq	This is the torque supplied by the generator when running at rated speed. See Figure 12 for details. This value must be greater than zero, but it is ignored if GenModel is not equal to 1 or VSContrl is not equal to 0. (N·m)
SIG_PORT	The pullout ratio is the ratio of the pullout torque and the rated torque. The negative of this value is also used for the startup torque. See Figure 12 for details. This value must be greater than or equal to one, but it is ignored if GenModel is not equal to 1 or VSContrl is not equal to 0. (-)

Thevenin-Equivalent, 3-Phase, Induction Generator

TEC_Freq	This is the line frequency of the electrical grid. This value must be greater than zero and should be 50 (Europe) or 60 (U.S.), but it is ignored if GenModel is not equal to 2 or VSContrl is not equal to 0. (Hz)
TEC_NPol	This is the number of poles in the generator. This value must be an even integer greater than zero, but it is ignored if GenModel is not equal to 2 or VSContrl is not equal to 0. (-)
TEC_SRes	This is the resistance of the generator stator in the complete circuit. This value must be greater than zero, but it is ignored if GenModel is not equal to 2 or VSContrl is not equal to 0. (ohms)
TEC_RRes	This is the resistance of the generator rotor in the complete circuit. This value must be greater than zero, but it is ignored if GenModel is not equal to 2 or VSContrl is not equal to 0. (ohms)
TEC_VLL	This is the line-to-line voltage of the generator. This value must be greater than zero and is often 690 in Europe or 480 or 575 in the U.S., but it is ignored if GenModel is not equal to 2 or VSContrl is not equal to 0. (volts)
TEC_SLR	This is the leakage reactance of the generator stator in the complete circuit. This value must be greater than zero, but it is ignored if GenModel is not equal to 2 or VSContrl is not equal to 0. It is usually a small number and is close in value to the stator resistance. (ohms)
TEC_RLR	This is the leakage reactance of the generator rotor in the complete circuit. This value must be greater than zero, but it is ignored if GenModel is not equal to 2 or VSContrl is not equal to 0. It is usually a small number and is close in value to the rotor resistance. (ohms)
TEC_MR	This is the magnetizing reactance of the complete generator circuit. This value must be greater than zero, but it is ignored if GenModel is not equal to 2 or VSContrl is not equal to 0. It is usually about 10-50 times greater than the leakage reactances. (ohms)

Table 8. Primary-Input-File Parameters (continued).

Platform Model

PtfmModel	This is a switch used to indicate the type of support platform and to tell FAST whether or not to read in an additional file of inputs for defining the model properties of the support platform (see next input PtfmFile). The additional inputs in PtfmFile pertain to the to the support platform configuration, motions, and loading. Setting PtfmModel to 1 specifies an onshore foundation. Setting it to 2 specifies a fixed bottom offshore foundation. Setting it to 3 specifies a floating offshore configuration. Setting PtfmModel to 0 disables the platform models—in this case, FAST will rigidly attach the tower to the inertia frame (ground) through a cantilever connection. Using values other than 0, 1, 2, or 3 will cause FAST to abort.
PtfmFile	This is the name of the file that contains additional model properties for the support platform. The name may optionally include an absolute or relative path. This file name must contain fewer than 100 characters and must be enclosed in apostrophes or double quotes. FAST will only read this file if PtfmModel is nonzero. See Table 12 for a listing of input parameters contained in this file. In FAST v6.0, all nonzero PtfmModel options will work the same way by reading in PtfmFile. In future versions, the format of this file will depend on which PtfmModel option is selected. (quoted string)

Tower

TwrNodes	The tower is divided into TwrNodes equal-length segments. The nodes at the centers of these segments are used for the integration of elastic forces. The more segments you use, the more accurate the integral will be, but the greater the computational time will be. A good compromise for this parameter is 20. This value must be an integer greater than 0. When creating ADAMS datasets, this value must be no more than 99. (-)
TwrFile	This is the name of the file that contains the tower properties. The name may optionally include an absolute or relative path. This file name must contain fewer than 100 characters and must be enclosed in apostrophes or double quotes. FAST will read this file even when there are no tower DOFs. See Table 9 for a listing of input parameters contained in this file. (quoted string)

Nacelle Yaw

YawSpr	This is the torsional spring stiffness in FAST’s built-in, second-order, nacelle yaw actuator model. The linear nacelle-yaw spring moment is proportional to the nacelle-yaw error through this constant. If a yaw actuator natural frequency is known in place of an actuator spring stiffness, compute the spring stiffness as follows: $YawSpr = YawIner \cdot \omega_n^2$, where ω_n is the natural frequency in rad/sec and YawIner is the nominal inertia of the nacelle, rotor, and tail about the yaw axis in $kg \cdot m^2$. This value must not be negative. (N·m/rad)
YawDamp	This is the torsional damping constant in FAST’s built-in, second-order, nacelle yaw actuator model. The linear nacelle-yaw damping moment is proportional to the nacelle-yaw rate error through this constant. If a yaw actuator natural frequency and damping ratio are known in place of an actuator damping constant, compute the damping constant as follows: $YawDamp = 2 \cdot \zeta \cdot YawIner \cdot \omega_n$, where ω_n is the natural frequency in rad/sec, ζ is the damping ratio in fraction of critical, and YawIner is the nominal inertia of the nacelle, rotor, and tail about the yaw axis in $kg \cdot m^2$. This value must not be negative. (N·m/(rad/sec))
YawNeut	When YCMode is 0, this is the neutral nacelle yaw position (constant yaw command) as described on page 12. When YCMode is not zero, this is the initial, constant yaw command before active yaw control is enabled at time TYCON. This value must be greater than -180 and less than or equal to 180 degrees. (deg)

Table 8. Primary-Input-File Parameters (continued).

Furling

Furling	This flag is used to tell FAST whether or not to read in an additional file of inputs for defining the model configuration of a furling turbine (see next input <code>FurlFile</code>). The additional inputs in <code>FurlFile</code> pertain to the lateral offset and skew angle of the rotor shaft, rotor-furling, tail-furling, and tail inertia and aerodynamics. If the turbine you want to model contains any of these characteristics, you must assemble the furling input file even if your turbine does not “furl” in the common sense of the word. For example, if the turbine you want to model contains a tail, you must assemble the furling input file regardless of whether or not your tail, or rotor, actively furls about the yawing-portion of the structure atop the tower. (flag)
FurlFile	This is the name of the file that contains additional model properties for a furling turbine. The name may optionally include an absolute or relative path. This file name must contain fewer than 100 characters and must be enclosed in apostrophes or double quotes. FAST will only read this file if the model is designated as a furling machine (when <code>Furling</code> is set to True). See Table 13 for a listing of input parameters contained in this file. (quoted string)

Rotor Teeter

TeetMod	The teeter springs and dampers can be modeled three ways. For a value of 0 for <code>TeetMod</code> , there will be no teeter spring nor damper and the moment normally produced will be set to zero. A <code>TeetMod</code> of 1 will invoke simple spring and damper models using the inputs provided below as appropriate coefficients. If you set <code>TeetMod</code> to 2, FAST will call the routine <code>UserTeet()</code> to compute the teeter spring and damper moments. You should replace the dummy routine supplied with the code with your own, which will need to be linked with the rest of FAST. Using values other than 0, 1, or 2 will cause FAST to abort. This parameter is ignored for three-bladed turbines. (switch)
TeetDmpP	The teeter damper is effective when the teeter deflection exceeds this value. This value must be between 0 and 180 degrees (inclusive). This parameter is ignored for three-bladed turbines and when <code>TeetMod</code> is not set to 1. (deg)
TeetDmp	The linear teeter damping moment is proportional to the teeter rate through this constant and is effective when the teeter deflection exceeds <code>TeetDmpP</code> . This value must not be negative. This parameter is ignored for three-bladed turbines and when <code>TeetMod</code> is not set to 1. (N·m/(rad/sec))
TeetCDmp	The Coulomb-friction damping moment resists teeter motion, but it is a constant that is not proportional to the teeter rate. However, if the teeter rate is zero, the damping is zero. This value must not be negative. This parameter is ignored for three-bladed turbines and when <code>TeetMod</code> is not set to 1. (N·m)
TeetSSStP	The teeter soft-stop spring is effective when the teeter deflection exceeds this value. This value must be between 0 and 180 degrees (inclusive). This parameter is ignored for three-bladed turbines and when <code>TeetMod</code> is not set to 1. (deg)
TeetHStP	The teeter hard-stop spring is effective when the teeter deflection exceeds this value. This value must be between <code>TeetSSStP</code> and 180 degrees (inclusive). This parameter is ignored for three-bladed turbines and when <code>TeetMod</code> is not set to 1. (deg)
TeetSSSp	The linear teeter soft-stop spring restoring moment is proportional to the teeter soft-stop deflection by this constant and is effective when the teeter deflection exceeds <code>TeetSSStP</code> . This value must not be negative. This parameter is ignored for three-bladed turbines and when <code>TeetMod</code> is not set to 1. (N·m/rad)
TeetHSSp	The linear teeter hard-stop spring restoring moment is proportional to the teeter hard-stop deflection by this constant and is effective when the teeter deflection exceeds <code>TeetHStP</code> . This value must not be negative. This parameter is ignored for three-bladed turbines and when <code>TeetMod</code> is not set to 1. (N·m/rad)

Table 8. Primary-Input-File Parameters (continued).

Tip Brakes

TBDrConN	When tip brakes are not deployed (normal operation), this value is multiplied by the dynamic pressure to produce the drag of the brakes at the tip of every blade. This value is C_d times the flat plate drag area. This value must not be negative. (m^2)
TBDrConD	When tip brakes are deployed (braking operation), the tip drag follows an S curve from TBDrConN to this fully deployed value. The resulting value is multiplied by the dynamic pressure to produce the drag of the brakes at the tip of every blade. This value is C_d times the flat plate drag area. This value must not be negative. (m^2)
TpBrDT	When tip brakes are deployed it takes TpBrDT seconds to fully deploy them. This value must not be negative. (m^2)

Blades

BldFile _i	This is the name of the file that contains the properties for the i^{th} blade. The names may optionally include an absolute or relative path. These file names must contain fewer than 100 characters and must be enclosed in apostrophes or double quotes. Only the first two names are used for two-bladed turbines. FAST will read this file even when there are no blade DOFs. See Table 10 for a listing of input parameters contained in this file. Please note that for three-bladed rotors, blade 3 is ahead of blade 2, which is ahead of blade 1, so that the order of blades passing through a given azimuth is 3-2-1-repeat. (quoted string)
----------------------	--

AeroDyn

ADFile	This is the name of the file that contains the AeroDyn aerodynamics parameters. The name may optionally include an absolute or relative path. This file name must contain fewer than 100 characters and must be enclosed in apostrophes or double quotes. FAST will read this file even when aerodynamic calculations are disabled. See Table 11 for a listing of input parameters contained in this file. (quoted string)
--------	--

Noise

NoiseFile	This is the name of the file that contains input parameters needed for aeroacoustic noise predictions. The name may optionally include an absolute or relative path. This file name must contain fewer than 100 characters and must be enclosed in apostrophes or double quotes. FAST will not read in this file if aerodynamic noise is not computed (when CompNoise is False) and during linearization analyses (when AnalMode is set to 2). Also, the inputs in this file do not effect the creation of ADAMS datasets. (quoted string)
-----------	--

ADAMS

ADAMSFile	This is the name of the file that contains input parameters needed only for creation of ADAMS datasets. The name may optionally include an absolute or relative path. This file name must contain fewer than 100 characters and must be enclosed in apostrophes or double quotes. FAST will not read in this file if ADAMS datasets are not generated (when ADAMSPrep is set to 1). See Table 14 for a listing of input parameters contained in this file. (quoted string)
-----------	---

Table 8. Primary-Input-File Parameters (continued).

Linearization Control

LinFile This is the name of the file that contains FAST linearization input parameters. The name may optionally include an absolute or relative path. This file name must contain fewer than 100 characters and must be enclosed in apostrophes or double quotes. FAST will not read in this file for time-marching analyses, when a linearization analysis is not performed (when **AnalMode** is set to 1) and the inputs in this file do not effect the creation of ADAMS datasets. See Table 15 for a listing of input parameters contained in this file. (quoted string)

Output

SumPrint Set this value to True if you want FAST to generate the summary file (see Figure 32). (flag)

TabDelim Set this value to True if you want FAST to delimit the tabular output data with tabs instead of using fixed-width columns. Tab-delimited files are easier to import into spreadsheets, and fixed-column files are better for viewing with a text editor or for printing. (flag)

OutFmt FAST will use this string as the numerical format specifier for output of floating-point values. The length of this string must not exceed 20 characters and must be enclosed in apostrophes or double quotes. You may not specify an empty string. To ensure that fixed-width column data align properly with the column titles, you should ensure that the width of the field is 10 characters. Using an E, EN, or ES specifier will guarantee that you will never overflow the field because the number is too big, but such numbers are harder to read. Using an F specifier will give you numbers that are easier to read, but you may overflow the field. Please refer to any Fortran manual for details for format specifiers. (quoted string)

TStart This tells the program how much simulation time should pass before outputting data to the tabular output file. A delay of at least five seconds is advised to allow the transient effects associated with starting from rest to damp out. This value must not be negative or greater than **TMax**. This parameter is ignored during a linearization analysis. (sec)

DecFact This parameter sets the decimation factor for output. FAST will output data only once each **DecFact** integration time steps. For instance, a value of 5 will cause FAST to generate output only every fifth time step. This value must be an integer greater than zero. (-)

SttsTime This parameter represents the amount of simulation time between the status messages that are displayed to the screen during the simulation. The messages show how much simulation time has elapsed and estimate when the job will complete. This value must be greater than zero. The value of this input does not effect the creation of ADAMS datasets. (sec)

NcIMUxn This is the downwind distance to the virtual nacelle inertial measurement unit (IMU) from the top of the tower, measured parallel to the x_n -axis. It is positive downwind. See Figure 14(a) and Figure 16. (m)

NcIMUyn This is the lateral distance to the virtual nacelle inertial measurement unit (IMU) from the top of the tower, measured parallel to the y_n -axis. It is positive to the left when looking downwind or positive into the page of Figure 14(a) and Figure 16. (m)

NcIMUzn This is the vertical distance to the virtual nacelle inertial measurement unit (IMU) from the top of the tower, measured parallel to the z_n -axis. It is positive upward when looking downwind. See Figure 14(a) and Figure 16. (m)

ShftGagL The distance from the teeter pin (two blades) or rotor apex (three blades) to the shaft-moment output station along the positive x_s axis allows you to put a virtual strain gage anywhere you like along the shaft. It is positive for upwind rotors. (m)

Table 8. Primary-Input-File Parameters (concluded).

Output (concluded)

NTwGages	The number of strain-gage locations along the tower indicates the number of input values on the next line. Valid values are integers from 0 to 5 (inclusive). (-)
TwrGagNd	<p>The virtual strain-gage locations along the tower are assigned to the tower analysis nodes specified on this line. Possible values are 1 to TwrNodes (inclusive), where 1 corresponds to the node closest to the tower base (but not at the base) and a value of TwrNodes corresponds to the node closest to the tower top. The exact elevations of each analysis node in the undeflected tower, relative to the base of the tower, are determined as follows:</p> $\text{Elev. of node } J = \text{TwrRBHt} + (J - \frac{1}{2}) \cdot [(\text{TowerHt} + \text{TwrDraft} - \text{TwrRBHt}) / \text{TwrNodes}]$ <p style="text-align: right;">(for $J = 1, 2, \dots, \text{TwrNodes}$)</p> <p>You must enter at least NTwGages values on this line. If NTwGages is 0, this line will be skipped, but you must have a line taking up space in the input file. You can separate the values with combinations of tabs, spaces, and commas, but you may use only one comma between numbers. (-)</p>
NBIGages	The number of strain-gage locations along the blade indicates the number of input values on the next line. Valid values are integers from 0 to 5 (inclusive). (-)
BldGagNd	<p>The virtual strain-gage locations along the blade are assigned to the blade analysis nodes specified on this line. Possible values are 1 to BldNodes (inclusive), where 1 corresponds to the node closest to the blade root (but not at the root) and a value of BldNodes corresponds to the node closest to the blade tip. The radial span locations of the analysis nodes are determined by AeroDyn input RNodes. You must enter at least NBIGages values on this line. If NBIGages is 0, this line will be skipped, but you must have a line taking up space in the input file. You can separate the values with combinations of tabs, spaces, and commas, but you may use only one comma between numbers. (-)</p>
OutList	<p>For a time-marching analysis, this list of parameters determines what you want printed in the output file. For a linearization analysis, this provides the list of output measurements. The line containing the array name OutList is a comment line, which must then be followed by one or more lines containing quoted strings that in turn contain one or more parameter names. Separate the parameter names by any combination of commas, semicolons, spaces, and/or tabs. If you prefix a parameter name with a minus sign, "-", underscore, "_", or the characters "m" or "M", FAST will multiply the value for that channel by -1 before writing the data. The parameters are written in the order they are listed in the input file. You may include any parameter as many times as you like. FAST allows you to use multiple lines so that you can break your list into meaningful groups and so the lines can be shorter. However, you cannot have the strings within the quotes longer than 1000 characters, so you are effectively limited to 100 channels per line in the input file. The limit on the total number of output channels in all lines is 200. During time-marching analyses, the simulation time will always be the first column in the output file and is not explicitly entered in this list. You may enter comments after the closing quote on any of the lines. For instance, you may want to group all of your blade loads together on one line and then comment the line to document the fact that they are blade loads. Entering a line with the string "END" at the beginning of the line or at the beginning of a quoted string found at the beginning of the line will cause FAST to quit scanning for more lines of channel names. See Table 16 through Table 44 for the list of possible parameters. (-)</p>

Table 9. Tower-Input-File Parameters.

The following input parameters are contained in the file indicated by input `TwrFile` from the primary input file. FAST will read this file even when there are no tower DOFs.

Tower

<code>NTwInpSt</code>	The table of tower sectional data that follows below has <code>NTwInpSt</code> rows of data. The values in this table will be interpolated to the <code>TwrNodes</code> analysis nodes. For uniform towers, you may set this value to 1 and include just one row in the table with the fractional height set to 0. This value must be an integer greater than 0. There is no upper limit on the number of input stations. (-)
<code>CalcTMode</code>	When set to True, this flag tells FAST to calculate the tower mode shapes internally instead of using the input mode shapes. This feature is NOT CURRENTLY ENABLED, so set the value to False. (flag)
<code>TwrFADmp_i</code>	This is the tower's fore-aft structural damping in percent of critical for the i^{th} bending mode. Typical values are 0.5%–1.5% and must be between 0 and 100 (inclusive). The damping ratio for the second mode should usually be greater than the damping ratio for the first mode. The value for the first mode is used to determine the tower fore-aft damping ratio for the FIELD statements of extracted ADAMS datasets. The value for the second mode does not effect the creation of ADAMS datasets. (%)
<code>TwrSSDmp_i</code>	This is the tower's side-to-side structural damping in percent of critical for the i^{th} bending mode. Typical values are 0.5%–1.5% and must be between 0 and 100 (inclusive). The damping ratio for the second mode should usually be greater than the damping ratio for the first mode. The value for the first mode is used to determine the tower side-to-side damping ratio for the FIELD statements of extracted ADAMS datasets. The value for the second mode does not effect the creation of ADAMS datasets. (%)

Tower Adjustment Factors

<code>FASTunr_i</code>	These tower stiffness tuners allow you to adjust the stiffness only during the calculation of the i^{th} tower fore-aft bending mode. Set them to 1.0 to leave the stiffness unchanged. The values of these inputs do not effect the creation of ADAMS datasets. (-)
<code>SSStunr_i</code>	These tower stiffness tuners allow you to adjust the stiffness only during the calculation of the i^{th} tower side-to-side bending mode. Set them to 1.0 to leave the stiffness unchanged. The values of these inputs do not effect the creation of ADAMS datasets. (-)
<code>AdjTwMa</code>	This factor adjusts the tower mass as it is input. This effects all calculations using the tower mass. Set it to 1.0 to leave the mass unchanged. (-)
<code>AdjFAST</code>	This factor adjusts the tower fore-aft stiffness as it is input. This effects all calculations using the tower fore-aft stiffness. Set it to 1.0 to leave the fore-aft stiffness unchanged. (-)
<code>AdjSSSt</code>	This factor adjusts the tower side-to-side stiffness, as it is input. This effects all calculations using the tower side-to-side stiffness. Set it to 1.0 to leave the side-to-side stiffness unchanged. (-)

Distributed Tower Properties

<code>HtFract</code>	This is the fractional height along tower for the other parameters in this table. Values must vary from 0 to 1. If you are modeling a uniform tower, set <code>NTwInpSt</code> to 1 and set <code>HtFract</code> to 0 for the single row of distributed tower properties. (-)
<code>TMassDen</code>	This is the tower section mass per unit length. It should be computed as the integral of the mass density over the cross-sectional area of the section. That is, $TMassDen = \iint \rho(x, y) dx dy$, where $\rho(x, y)$ is the mass density in kg/m^3 and x and y are the fore-aft and side-to-side distances in meters from the tower section mass center to the differential area element, respectively. These values must be greater than zero. (kg/m)

Table 9. Tower-Input-File Parameters (continued).

Distributed Tower Properties (continued)

TwFASTif	<p>This is the tower section fore-aft stiffness. It should be computed as the integral of the modulus of elasticity times the square of the fore-aft distance from the tower centerline to the differential area element over the cross-sectional area of the section. That is, $TwFASTif = \iint E(x, y) x^2 dx dy$, where $E(x, y)$ is the modulus of elasticity in N/m^2 and x and y are the fore-aft and side-to-side distances in meters from the tower centerline to the differential area element, respectively. These values must be greater than zero. ($N \cdot m^2$)</p>
TwSSStif	<p>This is the tower section side-to-side stiffness. It should be computed as the integral of the modulus of elasticity times the square of the side-to-side distance from the tower centerline to the differential area element over the cross-sectional area of the section. That is, $TwSSStif = \iint E(x, y) y^2 dx dy$, where $E(x, y)$ is the modulus of elasticity in N/m^2 and x and y are the fore-aft and side-to-side distances in meters from the tower centerline to the differential area element, respectively. These values must be greater than zero. ($N \cdot m^2$)</p>
TwGJStif	<p>This is the tower section torsion stiffness used for creation of ADAMS datasets. The FAST model does not use it. It should be computed as the integral of the modulus of rigidity times the square of the radial distance from the tower centerline to the differential area element over the cross-sectional area of the section. That is, $TwGJStif = \iint G(x, y) (x^2 + y^2) dx dy$, where $G(x, y)$ is the modulus of rigidity in N/m^2 and x and y are the fore-aft and side-to-side distances in meters from the tower centerline to the differential area element, respectively. When creating ADAMS datasets, these values must be greater than zero. If the ADAMS preprocessor is disabled, this input can be left blank. ($N \cdot m^2$)</p>
TwEASStif	<p>This is the tower section extensional stiffness used for creation of ADAMS datasets. The FAST model does not use it. It should be computed as the integral of the modulus of elasticity over the cross-sectional area of the section. That is, $TwEASStif = \iint E(x, y) dx dy$, where $E(x, y)$ is the modulus of elasticity in N/m^2 and x and y are the fore-aft and side-to-side distances in meters from the tower centerline to the differential area element, respectively. When creating ADAMS datasets, these values must be greater than zero. If the ADAMS preprocessor is disabled, this input can be left blank. (N)</p>
TwFAlner	<p>This is the tower section fore-aft mass inertia per unit length used for creation of ADAMS datasets. The FAST model does not use it. It should be computed as the integral of the mass density times the square of the fore-aft distance from the tower section mass center to the differential area element over the cross-sectional area of the section. That is, $TwFAlner = \iint \rho(x, y) x^2 dx dy$, where $\rho(x, y)$ is the mass density in kg/m^3 and x and y are the fore-aft and side-to-side distances in meters from the tower section mass center to the differential area element, respectively. When creating ADAMS datasets, these values must not be less than zero. If the ADAMS preprocessor is disabled, this input can be left blank. ($kg \cdot m$)</p>
TwSSIner	<p>This is the tower section side-to-side mass inertia per unit length used for creation of the ADAMS dataset. The FAST model does not use it. It should be computed as the integral of the mass density times the square of the side-to-side distance from the tower section mass center to the differential area element over the cross-sectional area of the section. That is, $TwSSIner = \iint \rho(x, y) y^2 dx dy$, where $\rho(x, y)$ is the mass density in kg/m^3 and x and y are the fore-aft and side-to-side distances in meters from the tower section mass center to the differential area element, respectively. When creating ADAMS datasets, these values must not be less than zero. If the ADAMS preprocessor is disabled, this input can be left blank. ($kg \cdot m$)</p>

Table 9. Tower-Input-File Parameters (concluded).

Distributed Tower Properties (concluded)

- TwFACgOf This is the tower section mass offset measured from the tower centerline in the fore-aft direction, positive downwind. It is used for creation of the ADAMS dataset. The FAST model does not use it. If the ADAMS preprocessor is disabled, this input can be left blank. (m)
- TwSScGOf This is the tower section mass offset measured from the tower centerline in the side-to-side direction, positive toward the left when looking downwind. It is used for creation of the ADAMS dataset. The FAST model does not use it. If the ADAMS preprocessor is disabled, this input can be left blank. (m)

Tower Fore-Aft Mode Shapes

- TwFAM1Sh_i These are the coefficients of the polynomial equation used to model the first fore-aft mode shape of the tower. The five coefficients (second through sixth) of the polynomial equation define the mode shape, where the variable in the polynomial varies from 0 to 1. The zeroth and first terms are not included in the list because they must always be 0 for cantilevered beams. The polynomial should describe a curve that has a value of 1 at the free end. That is, the five numbers must add up to 1. (-)
- TwFAM2Sh_i These are the coefficients of the polynomial equation used to model the second fore-aft mode shape of the tower. The five coefficients (second through sixth) of the polynomial equation define the mode shape, where the variable in the polynomial varies from 0 to 1. The zeroth and first terms are not included in the list because they must always be 0 for cantilevered beams. The polynomial should describe a curve that has a value of 1 at the free end. That is, the five numbers must add up to 1. (-)

Tower Side-to-Side Mode Shapes

- TwSSM1Sh_i These are the coefficients of the polynomial equation used to model the first side-to-side mode shape of the tower. The five coefficients (second through sixth) of the polynomial equation define the mode shape, where the variable in the polynomial varies from 0 to 1. The zeroth and first terms are not included in the list because they must always be 0 for cantilevered beams. The polynomial should describe a curve that has a value of 1 at the free end. That is, the five numbers must add up to 1. (-)
- TwSSM2Sh_i These are the coefficients of the polynomial equation used to model the second side-to-side mode shape of the tower. The five coefficients (second through sixth) of the polynomial equation define the mode shape, where the variable in the polynomial varies from 0 to 1. The zeroth and first terms are not included in the list because they must always be 0 for cantilevered beams. The polynomial should describe a curve that has a value of 1 at the free end. That is, the five numbers must add up to 1. (-)

Table 10. Blade-Input-File Parameters.

The following input parameters are contained in the file indicated by input `BldFile` from the primary input file. FAST will read this file even when there are no blade DOFs.

Blade Parameters

<code>NBlInpSt</code>	The table of blade sectional data that follows below has <code>NBlInpSt</code> rows of data for each blade. The values in this table will be interpolated to the <code>BldNodes</code> analysis nodes. For uniform (untwisted and untapered) blades, set this value to 1 and enter only one row in the distributed-properties table. For that row, set <code>BIFract</code> equal to zero. This value must be an integer greater than zero. There is no upper limit on the number of input stations. (-)
<code>CalcBMode</code>	When set to True, this flag tells FAST to calculate the blade mode shapes internally instead of using the input mode shapes. This feature is NOT CURRENTLY ENABLED, so set the value to False. (flag)
<code>BldFIDmp_i</code>	The structural damping for the i^{th} flapwise blade-bending mode is entered in percent of critical damping. Typical values are 0.5%–1.5% and must be between 0 and 100 (inclusive). The second mode should usually have a higher damping ratio than the first. The value for the first mode is used to determine the blade-flap damping ratio for the FIELD statements of extracted ADAMS datasets. The value for the second mode does not effect the creation of ADAMS datasets. (%)
<code>BldEdDmp</code>	The structural damping for the edgewise blade bending mode is entered in percent of critical damping. Typical values are 0.5%–1.5% and must be between 0 and 100 (inclusive). The value is used to determine the blade-edge damping ratio for the FIELD statements of extracted ADAMS datasets. (%)

Blade Adjustment Factors

<code>FIS_tTunr_i</code>	These flapwise stiffness tuners allow you to adjust the flapwise stiffness only during the calculation of the i^{th} flap-bending mode. Set them to 1 to leave the stiffnesses unchanged. The values of these inputs do not effect the creation of ADAMS datasets. (-)
<code>AdjBIMs</code>	This factor allows you to adjust equally all the blade mass densities in the Distributed Blade Properties section. The adjustment is made as the data are read in, so this adjustment will affect all calculations that depend on the blade mass properties. This value must be greater than 0. (-)
<code>AdjFIS_t</code>	This factor allows you to adjust equally all the flap stiffnesses in the Distributed Blade Properties section. The adjustment is made as the data are read in, so this adjustment will affect all calculations that depend on the blade stiffness. This value must be greater than 0. (-)
<code>AdjEdSt</code>	This factor allows you to adjust equally all the edge stiffnesses in the Distributed Blade Properties section. The adjustment is made as the data are read in, so this adjustment will affect all calculations that depend on the blade stiffness. This value must be greater than 0. (-)

Distributed Blade Properties

<code>BIFract</code>	This is the fractional distance of the blade along the blade pitch axis. Values must vary from 0 to 1. The first row, which corresponds to the root of the blade, must have a value of 0. The last row, which corresponds to the tip of the blade, must have a value of 1. FAST will interpolate this data table to produce values at the locations specified in the AeroDyn input file. If you don't want FAST to use linear interpolation for this, you should specify data at the same analysis nodes specified in the AeroDyn input file in addition to the root and tip points. (-)
----------------------	--

Table 10. Blade-Input-File Parameters (continued).

Distributed Blade Properties (continued)

AeroCent	<p>This input is used to locate the aerodynamic center of the corresponding airfoil section. AeroCent represents the fractional distance along the chordline from the leading to the trailing edge, where it is assumed that pitch axis passes through the airfoil section at 25% chord so that the leading edge is 25% ahead of the pitch axis along the chordline and the trailing edge is 75% aft of the pitch axis along the chordline. AeroCent is limited to values between 0.0 and 1.0; a value of 0.0 corresponds to the leading edge, a value of 0.25 corresponds to the blade pitch axis, and a value of 1.0 corresponds to the trailing edge in FAST models. If the pitch axis in the turbine blade you are trying to model does not actually pass through the airfoil section at 25% chord (at a cylindrical root, for example, where it passes at 50% chord), then the AeroCent input may cause confusion and may not correspond to notation you are used to. The following equation will convert from your notation to FAST's notation:</p> $\text{AeroCent} = 0.25 - [\text{(fraction of chord from leading edge to actual pitch axis)} - \text{(fraction of chord from leading edge to actual aerodynamic center)}]$ <p>For example, in a cylindrical root, where both the actual pitch axis and aerodynamic center lie at 50% chord, you must set AeroCent as follows:</p> $\text{AeroCent} = 0.25 - [(0.5) - (0.5)] = 0.25 \text{ (corresponding to the fact that the aerodynamic center lies on the pitch axis)}$ <p>Also as an example, if your pitch axis lies at 30% chord and the aerodynamic center lies at 25% chord, you must set AeroCent as follows:</p> $\text{AeroCent} = 0.25 - [(0.3) - (0.25)] = 0.20 \text{ (corresponding to the fact that the aerodynamic center lies 5\% ahead of the pitch axis)}$ <p>ADAMS models generated using the FAST-to-ADAMS preprocessor assume that the reference axis, indicated by inputs PrcrvRef and PreswpRef, passes through each airfoil section at 25% chord; thus, a value of 0.25 for AeroCent corresponds to the blade reference axis in ADAMS models. In this case, the equation above can be adopted if the reference axis in the turbine blade you are trying to model does not pass through 25% chord by substituting "pitch" with "reference". (-)</p>
StrcTwst	<p>This is the structural twist angle. It indicates the orientation of the principal axis. A positive structural twist is one that points the leading edge more upwind. These values must be greater than -180 and less than or equal to 180 degrees. (deg)</p>
BMassDen	<p>This is the blade section mass per unit length. It should be computed as the integral of the mass density over the cross-sectional area of the section. That is, $\text{BMassDen} = \iint \rho(x, y) dx dy$, where $\rho(x, y)$ is the mass density in kg/m^3 and x and y are the flapwise and edgewise distances in meters from the blade section mass center to the differential area element, respectively. These values must be greater than zero. (kg/m)</p>
FlpStff	<p>This is the blade section flapwise stiffness, not the out-of-plane stiffness. It should be computed as the integral of the modulus of elasticity times the square of the flapwise distance from the blade section elastic center to the differential area element over the cross-sectional area of the section. That is, $\text{FlpStff} = \iint E(x, y) x^2 dx dy$, where $E(x, y)$ is the modulus of elasticity in N/m^2 and x and y are the flapwise and edgewise distances in meters from the blade section elastic center to the differential area element, respectively. These values must be greater than zero. ($\text{N}\cdot\text{m}^2$)</p>

Table 10. Blade-Input-File Parameters (continued).

Distributed Blade Properties (continued)

EdgStff	This is the blade section edgewise stiffness, not the in-plane stiffness. It should be computed as the integral of the modulus of elasticity times the square of the edgewise distance from the blade section elastic center to the differential area element over the cross-sectional area of the section. That is, $\text{EdgStff} = \iint E(x, y)x^2 dx dy$, where $E(x, y)$ is the modulus of elasticity in N/m^2 and x and y are the flapwise and edgewise distances in meters from the blade section elastic center to the differential area element, respectively. These values must be greater than zero. ($\text{N}\cdot\text{m}^2$)
GJStff	This is the blade section torsion stiffness used for creation of the ADAMS dataset. The FAST model does not use it. It should be computed as the integral of the modulus of rigidity times the square of the radial distance from the blade section elastic center to the differential area element over the cross-sectional area of the section. That is, $\text{GJStff} = \iint G(x, y)(x^2 + y^2) dx dy$, where $G(x, y)$ is the modulus of rigidity in N/m^2 and x and y are the flapwise and edgewise distances in meters from the blade section elastic center to the differential area element, respectively. When creating ADAMS datasets, these values must be greater than zero. If the ADAMS preprocessor is disabled, this input can be left blank. (N m^2)
EASStff	This is the blade section extensional stiffness used for creation of the ADAMS dataset. The FAST model does not use it. It should be computed as the integral of the modulus of elasticity over the cross-sectional area of the section. That is, $\text{EASStff} = \iint E(x, y) dx dy$, where $E(x, y)$ is the modulus of elasticity in N/m^2 and x and y are the flapwise and edgewise distances in meters from the blade section elastic center to the differential area element, respectively. When creating ADAMS datasets, these values must be greater than zero. If the ADAMS preprocessor is disabled, this input can be left blank. (N)
Alpha	This is the blade section flap/twist coupling coefficient. Valued values are between -1 and 1 (exclusive). Positive values correspond to the blade twisting towards feather as the blade bends downwind due to thrust loading. Likewise, the blade will twist toward stall as it flaps downwind due to thrust loading if Alpha is negative. Set Alpha to zero to eliminate the coupling between flap bending and torsion. The FAST model does not use it. If the ADAMS preprocessor is disabled, this input can be left blank. (-)
Flplner	This is the blade section flapwise mass inertia per unit length used for creation of the ADAMS dataset. The FAST model does not use it. It should be computed as the integral of the mass density times the square of the flapwise distance from the blade section mass center to the differential area element over the cross-sectional area of the section. That is, $\text{Flplner} = \iint \rho(x, y)x^2 dx dy$, where $\rho(x, y)$ is the mass density in kg/m^3 and x and y are the flapwise and edgewise distances in meters from the blade section mass center to the differential area element, respectively. When creating ADAMS datasets, these values must not be less than zero. If the ADAMS preprocessor is disabled, this input can be left blank. (kg m)
Edglner	This is the blade section edgewise mass inertia per unit length used for creation of the ADAMS dataset. The FAST model does not use it. It should be computed as the integral of the mass density times the square of the edgewise distance from the blade section mass center to the differential area element over the cross-sectional area of the section. That is, $\text{Edglner} = \iint \rho(x, y)y^2 dx dy$, where $\rho(x, y)$ is the mass density in kg/m^3 and x and y are the flapwise and edgewise distances in meters from the blade section mass center to the differential area element, respectively. When creating ADAMS datasets, these values must not be less than zero. If the ADAMS preprocessor is disabled, this input can be left blank. (kg m)

Table 10. Blade-Input-File Parameters (concluded).

Distributed Blade Properties (concluded)

PrecrvRef	This is the sectional offset that defines the reference axis for precurved blades. This value is directed from the blade pitch axis along the $x_{b,i}$ -axis, positive nominally downwind. For upwind turbines, this value should be negative in order to increase tower clearance. PrecrvRef must be set to zero for blades without precurve. If PrecrvRef and PreswpRef (next input) are both zero, the reference axis and pitch axis are coincident. The FAST model does not use it. If the ADAMS preprocessor is disabled, this input can be left blank. (m)
PreswpRef	This is the sectional offset that defines the reference axis for preswept blades. This value is directed from the blade pitch axis along the $y_{b,i}$ -axis, negative in the direction of rotation. PreswpRef must be set to zero for blades without presweep. If PrecrvRef (previous input) and PreswpRef are both zero, the reference axis and pitch axis are coincident. The FAST model does not use it. If the ADAMS preprocessor is disabled, this input can be left blank. (m)
FlpcgOf	This is the blade section mass offset measured from the reference axis in the flapwise direction, positive toward the suction surface. It is used for creation of the ADAMS dataset. The FAST model does not use it. If the ADAMS preprocessor is disabled, this input can be left blank. (m)
EdgcgOf	This is the blade section mass offset measured from the reference axis in the edgewise direction, positive toward the trailing edge. It is used for creation of the ADAMS dataset. The FAST model does not use it. If the ADAMS preprocessor is disabled, this input can be left blank. (m)
FlpEAOOf	This is the blade section elastic offset measured from the reference axis in the flapwise direction, positive toward the suction surface. It is used for creation of the ADAMS dataset. The FAST model does not use it. If the ADAMS preprocessor is disabled, this input can be left blank. (m)
EdgEAOOf	This is the blade section elastic offset measured from the reference axis in the edgewise direction, positive toward the trailing edge. It is used for creation of the ADAMS dataset. The FAST model does not use it. If the ADAMS preprocessor is disabled, this input can be left blank. (m)

Blade Mode Shapes

BldFI1Sh _i	These are the coefficients of the polynomial equation used to model the first flapwise mode shape of the blade. The five coefficients (second through sixth) of the polynomial equation define the mode shape, where the variable in the polynomial varies from 0 to 1. The zeroth and first terms are not included in the list because they must always be 0 for cantilevered beams. The polynomial should describe a curve that has a value of 1 at the free end. That is, the five numbers must add up to 1. (-)
BldFI2Sh _i	These are the coefficients of the polynomial equation used to model the second flapwise mode shape of the blade. The five coefficients (second through sixth) of the polynomial equation define the mode shape, where the variable in the polynomial varies from 0 to 1. The zeroth and first terms are not included in the list because they must always be 0 for cantilevered beams. The polynomial should describe a curve that has a value of 1 at the free end. That is, the five numbers must add up to 1. (-)
BldEdgSh _i	These are the coefficients of the polynomial equation used to model the edgewise mode shape of the blade. The five coefficients (second through sixth) of the polynomial equation define the mode shape, where the variable in the polynomial varies from 0 to 1. The zeroth and first terms are not included in the list because they must always be 0 for cantilevered beams. The polynomial should describe a curve that has a value of 1 at the free end. That is, the five numbers must add up to 1. (-)

Table 11. AeroDyn-Input-File Parameters.

The following input parameters are contained in the file indicated by input **ADFile** from the primary input file. AeroDyn will read this file even when **CompAero** from the primary input file is disabled. For more details about the parameters documented here, please see the latest AeroDyn User's Guide [1].

Aerodynamics

ADTitle	This is an input-file descriptor that is displayed on the screen during execution. AeroDyn will read the first 96 characters of the text. There is no need to put it in quotes. You may enter anything you like—even an empty string, but you must consume exactly one line in the input file. (nonquoted string)
SysUnits	This string controls the setting of the SIUnits flag, which tells AeroDyn whether to assume input and output parameters are given in metric or English units. This string must be "SI" for FAST. Some other codes that use AeroDyn allow input and output parameters in English units, but FAST does not. (nonquoted string)
StallMod	This string controls the setting of the DynStall flag, which tells AeroDyn whether or not to use the Leishman-Beddoes dynamic stall in AeroDyn. The only permissible values are "BEDDOES" and "STEADY". This string is normally set to "BEDDOES" to use dynamic stall for production simulations. During a linearization analysis, dynamic stall must be disabled by specifying StallMod to "STEADY". (nonquoted string)
UseCm	This string controls the setting of the PitchMom flag, which tells AeroDyn whether to compute pitching moments in AeroDyn. The only permissible values are "USE_CM" and "NO_CM". Although pitching moments will have an effect on the loads and motion of the turbine in FAST, there is no twist degree of freedom. (nonquoted string)
InfModel	This string controls the setting of the DynInfl flag, which tells AeroDyn whether to use the generalized-dynamic-wake model or the equilibrium-inflow model. The two possible string values are "DYNIN" and "EQUIL". For production runs, this string should be set to "DYNIN". During a linearization analysis, the "EQUIL" equilibrium-inflow model must be engaged. (nonquoted string)
IndModel	When using the equilibrium-inflow model, this quoted string controls the setting of the AxialInd and TangInd flags. The three possible values are "NONE", "WAKE", and "SWIRL". A setting of "NONE" disables both flags, a setting of "WAKE" enables just the AxialInd flag, and a setting of "SWIRL" enables both flags. If you are doing production runs using equilibrium inflow, you should set this value to "SWIRL". (nonquoted string)
AToler	When using the equilibrium inflow model, an iterative solution is used to calculate the induction factors. AeroDyn uses the value of AToler as the convergence criterion. A good default value to use is 0.005. This value may be reduced to increase accuracy or increased to speed the calculations. This value must be greater than zero. (-)
TLModel	When using the equilibrium inflow model, you can select from two tip-loss models or disable tip-loss calculations. {"NONE": no tip-loss calculations, "PRAND": standard Prandtl tip-loss model, "GTECH": Georgia Tech's modified Prandtl model} (nonquoted string)
HLMModel	When using the equilibrium inflow model, you can include or disable hub-loss calculations. {"NONE": no hub-loss calculations, "PRAND": standard Prandtl hub-loss model} (nonquoted string)
WindFile	This quoted string holds the name or root name of the wind input file. AeroDyn will check the file system to determine whether the file contains hub-height wind data or full-field (FF) wind data. For FF winds, omit the file extension. The file name may optionally include an absolute or relative path. This file name must contain fewer than 100 characters and must be enclosed in apostrophes or double quotes. During a linearization analysis, you must use a hub-height wind data file that does not vary with time. (quoted string)
HH	This is the height above the ground [onshore] or height above the mean sea level [offshore] that AeroDyn will use as a hub height for the winds. You should set this to $\text{TowerHt} + \text{Twr2Shft} + \text{OverHang} \cdot \text{SIN}(\text{ShftTilt})$. This value must not be negative. (m)

Table 11. AeroDyn-Input-File Parameters (continued).

Aerodynamics (concluded)

TwrShad	The tower-shadow maximum velocity deficit is the fractional amount the horizontal wind speed is reduced at the middle of the shadow a distance T_Shad_RefPt downstream from the center of the tower. This varies from 0 to 1. A value of 0 means there is no shadow. A value of 1 means the wind is completely stopped. A typical number might be something like 0.3. This value must not be negative. (-)
ShadHWid	The tower-shadow half-width tells AeroDyn how wide the tower shadow is at a distance T_Shad_RefPt downstream from the center of the tower. This number should normally be slightly larger than the half-width of the tower, as the tower shadow usually widens as it goes downstream. This value must not be negative. (m)
T_Shad_RefPt	This distance downstream of the tower specifies the point where the input values of the velocity deficit and shadow width are defined. An appropriate value would be the horizontal distance from the tower centerline to the hub, which would be $OverHang \cdot \cos(ShftTilt)$. This value must not be negative. (m)
Rho	This is the ambient air density at the altitude of the hub. The standard density at sea level is 1.225. By setting this value to 0 you will effectively eliminate all aerodynamic forces on the turbine, but you will save a lot of calculations by instead disabling the CompAero flag. This value must not be negative. (kg/m ³)
KinVisc	This is the ambient relative viscosity at the altitude of the hub. This value is not currently used in AeroDyn or FAST, but it will eventually be used to compute the Reynolds number. The standard relative viscosity at sea level is 1.46e-5. This value must not be negative. (kg/m·sec)
DTAero	This is the time step size that tells AeroDyn how often to compute aerodynamic forces. This value must be greater than zero. It does not need to be specified as an integral multiplier of FAST's time step, DT , but if it is not, FAST will still only call AeroDyn at the least greatest integer multiple of DT that is larger or equal to DTAero . (sec)
NumFoil	This parameter determines how many airfoil tables will be available for assignment to the various blade stations and tail fin airfoil. Any non-zero number of airfoil files can be specified. Any or all of them may be used by more than one blade station or never used at all. (-)
FoilNm _i	The next NumFoil lines are a list of airfoil-table file names entered in quoted strings. The file names are limited to 80 characters and may contain absolute or relative paths. Leading and trailing spaces are trimmed, but imbedded spaces are kept. Leading spaces count against the 80-character limit. Only one filename is entered on each line. (quoted strings)
BldNodes	The blades will have BldNodes analysis nodes in FAST, which are used for the integration of aerodynamic and elastic forces. The more segments you use, the more accurate the integral will be, but the greater the computational time will be. A good compromise for this parameter is 20. This integer number must be greater than 1. When creating ADAMS datasets, this value must be no more than 99. (-)

Table 11. AeroDyn-Input-File Parameters (concluded).

Distributed Blade Information

RNodes	These values are the distances of the analysis nodes from the rotor apex along the pitch axis, which is not consistent with the YawDyn convention for 3-bladed turbines (but is consistent for 2-bladed turbines). The analysis nodes are located at the centers of the blade segments. You do not have complete freedom to put the RNodes anywhere you like. For instance, they cannot be at the blade root or tip. It is also not always possible to alternate between nodes that are close together and far apart. An easy way to ensure consistency is to divide the blade segments and then compute the centers of the segments to use for the RNodes. The nodes do not need to be equally spaced. These values must fall between the HubRad and TipRad (exclusive). (m)
AeroTwst	This is the aerodynamic twist angle. It indicates the orientation of the chord of the local airfoil. A positive aerodynamic twist is one that points the leading edge more upwind. These values must be greater than -180 and less than or equal to 180 degrees. (deg)
DRNodes	These values represent the portion of the blade span that is assigned to an analysis node. This length times the local chord defines the area used in the aerodynamics calculations. The sum of all the DRNodes should add up to the blade length. FAST checks the values of the RNodes and DRNodes to make sure they are consistent and meaningful. These values must be greater than zero. (m)
Chord	These values are the local chords of the analysis nodes. This local chord times DRNodes defines the area used in the aerodynamics calculations. These values must be greater than zero. (m)
NFoil	These integers tell AeroDyn which of the input airfoil files (FoilNm) are assigned to the various analysis nodes. For instance, a value of 2 means that node 2 will use FoilNm ₂ for the local airfoil. Airfoils may be assigned to more than one blade station. These values must be between 1 and NumFoil. (-)
PrnElm	If the whole word "PRINT" is found anywhere on a line, the element data for that element will be printed to the element output file (<i>element.plt</i>). You can also enter the nonquoted string "NOPRINT", or leave this field blank to skip printing element data for this element. (nonquoted, case-insensitive string)

Table 12. Platform-Input-File Parameters.

The following input parameters are contained in the file indicated by input **PtfmFile** from the primary input file. FAST will only read this file if **PtfmModel** from the primary input file is nonzero. In FAST v6.0, all nonzero **PtfmModel** options will work the same way by reading in the **PtfmFile** described here. In future versions, the format of this file will depend on which **PtfmModel** option is selected.

Feature Flags

PtfmSgDOF	The support platform surge DOF will be enabled when this is True. The surge DOF allows the platform to translate horizontally relative to the inertia frame as shown in Figure 20. The platform reference point (located by input PtfmRef) translates with the platform during this motion. The initial surge displacement is specified with PtfmSurge . If PtfmSgDOF is disabled, the surge displacement will be fixed at PtfmSurge . (flag)
PtfmSwDOF	The support platform sway DOF will be enabled when this is True. The sway DOF allows the platform to translate horizontally relative to the inertia frame as shown in Figure 20. The platform reference point (located by input PtfmRef) translates with the platform during this motion. The initial sway displacement is specified with PtfmSway . If PtfmSwDOF is disabled, the sway displacement will be fixed at PtfmSway . (flag)
PtfmHvDOF	The support platform heave DOF will be enabled when this is True. The heave DOF allows the platform to translate vertically relative to the inertia frame as shown in Figure 20. The platform reference point (located by input PtfmRef) translates with the platform during this motion. The initial heave displacement is specified with PtfmHeave . If PtfmHvDOF is disabled, the heave displacement will be fixed at PtfmHeave . (flag)
PtfmRDOF	The support platform roll DOF will be enabled when this is True. The roll DOF allows the platform to tilt (rotate) about its reference point (located by input PtfmRef) relative to the inertia frame as shown in Figure 20. The initial roll displacement is specified with PtfmRoll . If PtfmRDOF is disabled, the roll displacement will be fixed at PtfmRoll . (flag)
PtfmPDOF	The support platform pitch DOF will be enabled when this is True. The pitch DOF allows the platform to tilt (rotate) about its reference point (located by input PtfmRef) relative to the inertia frame as shown in Figure 20. The initial pitch displacement is specified with PtfmPitch . If PtfmPDOF is disabled, the pitch displacement will be fixed at PtfmPitch . (flag)
PtfmYDOF	The support platform yaw DOF will be enabled when this is True. The yaw DOF allows the platform to yaw (rotate) about its reference point (located by input PtfmRef) relative to the inertia frame as shown in Figure 20. The initial yaw displacement is specified with PtfmYaw . If PtfmYDOF is disabled, the yaw displacement will be fixed at PtfmYaw . (flag)

Initial Conditions

PtfmSurge	This is the fixed or initial support platform surge displacement. The surge displacement indicates a horizontal translation of the platform relative to the inertia frame as shown in Figure 20. (m)
PtfmSway	This is the fixed or initial support platform sway displacement. The sway displacement indicates a horizontal translation of the platform relative to the inertia frame as shown in Figure 20. (m)
PtfmHeave	This is the fixed or initial support platform heave displacement. The heave displacement indicates a vertical translation of the platform relative to the inertia frame as shown in Figure 20. (m)
PtfmRoll	This is the fixed or initial support platform roll displacement. The roll displacement indicates a tilt rotation of the platform about its reference point (located by input PtfmRef) relative to the inertia frame as shown in Figure 20. This value must be between -15 and 15 degrees (inclusive). (deg)
PtfmPitch	This is the fixed or initial support platform pitch displacement. The pitch displacement indicates a tilt rotation of the platform about its reference point (located by input PtfmRef) relative to the inertia frame as shown in Figure 20. This value must be between -15 and 15 degrees (inclusive). (deg)
PtfmYaw	This is the fixed or initial support platform yaw displacement. The yaw displacement indicates a yaw rotation of the platform about its reference point (located by input PtfmRef) relative to the inertia frame as shown in Figure 20. This value must be between -15 and 15 degrees (inclusive). (deg)

Table 12. Platform-Input-File Parameters (concluded).

Turbine Configuration

TwrDraft	The tower draft is the downward distance from ground level [onshore] or mean sea level [offshore] to the tower base platform connection. This value must be greater than $-TowerHt$. See Figure 20. (m)
PtfmCM	This is the downward distance from ground level [onshore] or mean sea level [offshore] to the support platform mass center. This value must not be less than TwrDraft . See Figure 20. (m)
PtfmRef	This is the downward distance from ground level [onshore] or mean sea level [offshore] to the support platform reference point. The platform reference point is the origin in the platform about which the translational (surge, sway, and heave) and rotational (roll, pitch, and yaw) motions of the support platform are defined. It is also the point at which external loading is applied to the platform—see input parameter PtfmLdMod . This value must not be less than TwrDraft . See Figure 20. (m)

Mass and Inertia

PtfmMass	This is the mass of the support platform. Its center is located a downward distance of PtfmCM from ground level [onshore] or mean sea level [offshore]. If TwrRBHt is nonzero, the mass of the rigid portion of the tower should be included with the support platform mass in PtfmMass . This value must not be negative. (kg)
PtfmRIner	This is the support platform moment of inertia in roll about the platform mass center. It includes all mass contained in PtfmMass . This value must not be negative. ($kg \cdot m^2$)
PtfmPIner	This is the support platform moment of inertia in pitch about the platform mass center. It includes all mass contained in PtfmMass . This value must not be negative. ($kg \cdot m^2$)
PtfmYIner	This is the support platform moment of inertia in yaw about the platform mass center. It includes all mass contained in PtfmMass . This value must not be negative. ($kg \cdot m^2$)

Platform Loading

PtfmLdMod	In FAST v6.0, only user-defined platform loading is available. For a value of 0 for PtfmLdMod , there will be no platform loading and the support reactions normally produced will be set to zero (causing the wind turbine to fall due to gravity if PtfmHvDOF is True). If you set PtfmLdMod to 1, FAST will call the routine UserPtfmLd() to compute the platform loading. You should replace the dummy routine supplied with the code with your own, which will need to be linked with the rest of FAST. The platform loads returned by UserPtfmLd() should contain contributions from any external load acting on the platform other than loads transmitted from the wind turbine. For example, these loads should contain contributions from foundation stiffness and damping [not floating] or mooring line restoring and damping [floating], as well as hydrostatic and hydrodynamic contributions [offshore]. The platform loads will be applied on the platform at the instantaneous platform reference position (located by input PtfmRef). The routine assumes that the platform loads are transmitted through a medium like soil [foundation] and/or water [offshore], so that added mass effects are important. See the dummy UserPtfmLd() routine for more information. Using values other than 0 or 1 for PtfmLdMod will cause FAST to abort. (switch)
------------------	---

Table 13. Furling-Input-File Parameters.

The following input parameters are contained in the file indicated by input `FurlFile` from the primary input file. FAST will only read this file if the model is designated as a furling machine (when `Furling` from the primary input file is set to `True`).

Feature Flags

- RFrIDOF** The rotor-furl DOF will be enabled when this is `True`. The initial rotor-furl angle is specified with `RotFurl`. If `RFrIDOF` is disabled, the rotor-furl angle will be fixed at `RotFurl`. (flag)
- TFrIDOF** The tail-furl DOF will be enabled when this is `True`. The initial tail-furl angle is specified with `TailFurl`. If `TFrIDOF` is disabled, the tail-furl angle will be fixed at `TailFurl`. (flag)

Initial Conditions

- RotFurl** This is the fixed or initial rotor-furl angle. It is positive about the rotor-furl axis as shown in Figure 17. The rotor-furl axis is defined through inputs `RFrIPntxn`, `RFrIPntyn`, `RFrIPntzn`, `RFrISkew`, and `RFrITilt` below. This value must be greater than -180 and less than or equal to 180 degrees. (deg)
- TailFurl** This is the fixed or initial tail-furl angle. It is positive about the tail-furl axis as shown in Figure 17. The tail-furl axis is defined through inputs `TFrIPntxn`, `TFrIPntyn`, `TFrIPntzn`, `TFrISkew`, and `TFrITilt` below. This value must be greater than -180 and less than or equal to 180 degrees. (deg)

Turbine Configuration

- Yaw2Shft** This is the lateral offset distance from the yaw axis to the intersection of the rotor shaft axis with the y_n/z_n -plane. The distance is measured parallel to the y_n -axis. It is positive to the left when looking downwind as shown in Figure 18. For turbines with rotor-furl, this distance defines the configuration at a furl angle of zero. (m)
- ShftSkew** This is the skew angle of the rotor shaft in the nominally horizontal plane. Positive skew acts like positive nacelle yaw as shown in Figure 18; however, `ShftSkew` should only be used to skew the shaft a few degrees away from the zero-yaw position and must not be used as a replacement for the yaw angle. This value must be between -15 and 15 degrees (inclusive). For turbines with rotor-furl, this angle defines the configuration at a furl angle of zero. (deg)
- RFrICMxn** This is the downwind distance to the center of mass of the structure that furls with the rotor (not including the rotor—reference input `RFrIMass`) from the top of the tower, measured parallel to the x_n -axis. It is positive downwind. See Figure 18. For turbines with rotor-furl, this distance defines the configuration at a furl angle of zero. (m)
- RFrICMyn** This is the lateral distance to the center of mass of the structure that furls with the rotor (not including the rotor—reference input `RFrIMass`) from the top of the tower, measured parallel to the y_n -axis. It is positive to the left when looking downwind. See Figure 18. For turbines with rotor-furl, this distance defines the configuration at a furl angle of zero. (m)
- RFrICMzn** This is the vertical distance to the center of mass of the structure that furls with the rotor (not including the rotor—reference input `RFrIMass`) from the top of the tower, measured parallel to the z_n -axis. It is positive upward when looking downwind. See Figure 18. For turbines with rotor-furl, this distance defines the configuration at a furl angle of zero. (m)
- BoomCMxn** This is the downwind distance to the tail boom mass center (reference input `BoomMass`) from the top of the tower, measured parallel to the x_n -axis. It is positive downwind. See Figure 19. For turbines with tail-furl, this distance defines the configuration at a furl angle of zero. (m)
- BoomCMyn** This is the lateral distance to the tail boom mass center (reference input `BoomMass`) from the top of the tower, measured parallel to the y_n -axis. It is positive to the left when looking downwind. See Figure 19. For turbines with tail-furl, this distance defines the configuration at a furl angle of zero. (m)
- BoomCMzn** This is the vertical distance to the tail boom mass center (reference input `BoomMass`) from the top of the tower, measured parallel to the z_n -axis. It is positive upward when looking downwind. See Figure 19. For turbines with tail-furl, this distance defines the configuration at a furl angle of zero. (m)

Table 13. Furling-Input-File Parameters (continued).

Turbine Configuration (continued)

TFinCMxn	This is the downwind distance to the tail fin mass center (reference input TFinMass) from the top of the tower, measured parallel to the x_n -axis. It is positive downwind. See Figure 19. For turbines with tail-furl, this distance defines the configuration at a furl angle of zero. (m)
TFinCMyn	This is the lateral distance to the tail fin mass center (reference input TFinMass) from the top of the tower, measured parallel to the y_n -axis. It is positive to the left when looking downwind. See Figure 19. For turbines with tail-furl, this distance defines the configuration at a furl angle of zero. (m)
TFinCMzn	This is the vertical distance to the tail fin mass center (reference input TFinMass) from the top of the tower, measured parallel to the z_n -axis. It is positive upward when looking downwind. See Figure 19. For turbines with tail-furl, this distance defines the configuration at a furl angle of zero. (m)
TFinCPxn	This is the downwind distance to the tail fin center-of-pressure from the top of the tower, measured parallel to the x_n -axis. It is positive downwind. See Figure 19. For turbines with tail-furl, this distance defines the configuration at a furl angle of zero. (m)
TFinCPyn	This is the lateral distance to the tail fin center-of-pressure from the top of the tower, measured parallel to the y_n -axis. It is positive to the left when looking downwind. See Figure 19. For turbines with tail-furl, this distance defines the configuration at a furl angle of zero. (m)
TFinCPzn	This is the vertical distance to the tail fin center-of-pressure from the top of the tower, measured parallel to the z_n -axis. It is positive upward when looking downwind. See Figure 19. For turbines with tail-furl, this distance defines the configuration at a furl angle of zero. (m)
TFinSkew	This is the skew angle of the tail fin chordline in the nominally horizontal plane. Positive skew orients the nominal horizontal projection of the tail fin chordline about the z_n -axis. The aforementioned chordline is the chordline passing through the tail fin center-of-pressure. See Figure 19. This value must be greater than -180 and less than or equal to 180 degrees. For turbines with tail-furl, this angle defines the configuration at a furl angle of zero. (deg)
TFinTilt	This is the tilt angle of the tail fin chordline from the nominally horizontal plane. The aforementioned chordline is the chordline passing through the tail fin center-of-pressure. This value must be between -90 and 90 degrees (inclusive). Positive tilt means that the trailing edge of the tail fin is higher than the leading edge. See Figure 19. For turbines with tail-furl, this angle defines the configuration at a furl angle of zero. (deg)
TFinBank	This is the bank angle of the tail fin plane about the tail fin chordline. The aforementioned chordline is the chordline passing through the tail fin center-of-pressure. This value must be greater than -180 and less than or equal to 180 degrees. See Figure 19. For turbines with tail-furl, this angle defines the configuration at a furl angle of zero. (deg)
RFrlPntxn	This is the downwind distance to an arbitrary point on the rotor-furl axis from the top of the tower, measured parallel to the x_n -axis. It is positive downwind. The arbitrary point referred to in this input must be the same point identified by inputs RFrlPntyn and RFrlPntzn. Inputs RFrlPntxn, RFrlPntyn, RFrlPntzn, RFrlSkew, and RFrlTilt define the orientation of the rotor-furl axis and associated DOF, RFrlDOF. See Figure 17. (m)
RFrlPntyn	This is the lateral distance to an arbitrary point on the rotor-furl axis from the top of the tower, measured parallel to the y_n -axis. It is positive to the left when looking downwind. The arbitrary point referred to in this input must be the same point identified by inputs RFrlPntxn and RFrlPntzn. Inputs RFrlPntxn, RFrlPntyn, RFrlPntzn, RFrlSkew, and RFrlTilt define the orientation of the rotor-furl axis and associated DOF, RFrlDOF. See Figure 17. (m)
RFrlPntzn	This is the vertical distance to an arbitrary point on the rotor-furl axis from the top of the tower, measured parallel to the z_n -axis. It is positive upward when looking downwind. The arbitrary point referred to in this input must be the same point identified by inputs RFrlPntxn and RFrlPntyn. Inputs RFrlPntxn, RFrlPntyn, RFrlPntzn, RFrlSkew, and RFrlTilt define the orientation of the rotor-furl axis and associated DOF, RFrlDOF. See Figure 17. (m)

Table 13. Furling-Input-File Parameters (continued).

Turbine Configuration (concluded)

RFrlSkew	This is the skew angle of the rotor-furl axis in the nominally horizontal plane. Positive skew orients the nominal horizontal projection of the rotor-furl axis about the Z_n -axis. Inputs RFrlPntxn, RFrlPntyn, RFrlPntzn, RFrlSkew, and RFrlTilt define the orientation of the rotor-furl axis and associated DOF, RFrlDOF. See Figure 17. This value must be greater than -180 and less than or equal to 180 degrees. (deg)
RFrlTilt	This is the tilt angle of the rotor-furl axis from the nominally horizontal plane. This value must be between -90 and 90 degrees (inclusive). Inputs RFrlPntxn, RFrlPntyn, RFrlPntzn, RFrlSkew, and RFrlTilt define the orientation of the rotor-furl axis and associated DOF, RFrlDOF. See Figure 17. (deg)
TFrlPntxn	This is the downwind distance to an arbitrary point on the tail-furl axis from the top of the tower, measured parallel to the x_n -axis. It is positive downwind. The arbitrary point referred to in this input must be the same point identified by inputs TFrlPntyn and TFrlPntzn. Inputs TFrlPntxn, TFrlPntyn, TFrlPntzn, TFrlSkew, and TFrlTilt define the orientation of the tail-furl axis and associated DOF, TFrlDOF. See Figure 17. (m)
TFrlPntyn	This is the lateral distance to an arbitrary point on the tail-furl axis from the top of the tower, measured parallel to the y_n -axis. It is positive to the left when looking downwind. The arbitrary point referred to in this input must be the same point identified by inputs TFrlPntxn and TFrlPntzn. Inputs TFrlPntxn, TFrlPntyn, TFrlPntzn, TFrlSkew, and TFrlTilt define the orientation of the tail-furl axis and associated DOF, TFrlDOF. See Figure 17. (m)
TFrlPntzn	This is the vertical distance to an arbitrary point on the tail-furl axis from the top of the tower, measured parallel to the Z_n -axis. It is positive upward when looking downwind. The arbitrary point referred to in this input must be the same point identified by inputs TFrlPntxn and TFrlPntyn. Inputs TFrlPntxn, TFrlPntyn, TFrlPntzn, TFrlSkew, and TFrlTilt define the orientation of the tail-furl axis and associated DOF, RFrlDOF. See Figure 17. (m)
TFrlSkew	This is the skew angle of the tail-furl axis in the nominally horizontal plane. Positive skew orients the nominal horizontal projection of the tail-furl axis about the Z_n -axis. Inputs TFrlPntxn, TFrlPntyn, TFrlPntzn, TFrlSkew, and TFrlTilt define the orientation of the tail-furl axis and associated DOF, TFrlDOF. See Figure 17. This value must be greater than -180 and less than or equal to 180 degrees. (deg)
TFrlTilt	This is the tilt angle of the tail-furl axis from the nominally horizontal plane. This value must be between -90 and 90 degrees (inclusive). Inputs TFrlPntxn, TFrlPntyn, TFrlPntzn, TFrlSkew, and TFrlTilt define the orientation of the tail-furl axis and associated DOF, TFrlDOF. See Figure 17. (deg)

Mass and Inertia

RFrlMass	This is the mass of the structure that furls with the rotor (not including the rotor). The center of this mass is located at the point specified by inputs RFrlCMxn, RFrlCMyn, and RFrlCMzn relative to the tower-top at a rotor-furl angle of zero. It includes everything that furls with the rotor excluding the rotor (blades, hub, and tip brakes). This value must not be negative. (kg)
BoomMass	This is the mass of the tail boom. The center of the tail boom mass is located at the point specified by inputs BoomCMxn, BoomCMyn, and BoomCMzn relative to the tower-top at a tail-furl angle of zero. It includes everything that furls with the tail except the tail fin (see next input). This value must not be negative. (kg)
TFinMass	This is the mass of the tail fin. The center of the tail fin mass is located at the point specified by inputs TFinCMxn, TFinCMyn, and TFinCMzn relative to the tower-top at a tail-furl angle of zero. TFinMass and BoomMass combined should include everything that furls with the tail. This value must not be negative. (kg)
RFrlIner	This is the moment of inertia of the structure that furls with the rotor (not including the rotor) about the rotor-furl axis. It includes all mass contained in RFrlMass. This value must be greater than $RFrlMass \cdot (\textit{perpendicular distance between rotor-furl axis and C.M. of the structure that furls with the rotor [not including the rotor]})^2$. (kg·m ²)

Table 13. Furling-Input-File Parameters (continued).

Mass and Inertia (concluded)

TFrIner This is the tail boom moment of inertia about the tail-furl axis. It includes all mass contained in BoomMass. This value must be greater than $\text{BoomMass} \cdot (\text{perpendicular distance between tail-furl axis and tail boom C.M.})^2$. (kg·m²)

Rotor-Furl

RFrIMod The rotor-furl springs and dampers can be modeled three ways. For a value of 0 for RFrIMod, there will be no rotor-furl spring nor damper and the moment normally produced will be set to zero. A RFrIMod of 1 will invoke simple spring and damper models using the inputs provided below as appropriate coefficients. If you set RFrIMod to 2, FAST will call the routine UserRFrI() to compute the rotor-furl spring and damper moments. You should replace the dummy routine supplied with the code with your own, which will need to be linked with the rest of FAST. Using values other than 0, 1, or 2 will cause FAST to abort. (switch)

RFrISpr The linear rotor-furl spring restoring moment is proportional to the rotor-furl deflection through this constant. This value must not be negative and is only used when RFrIMod is set to 1. (N·m/rad)

RFrIDmp The linear rotor-furl damping moment is proportional to the rotor-furl rate through this constant. This value must not be negative and is only used when RFrIMod is set to 1. (N·m/(rad/sec))

RFrICDmp This Coulomb-friction damping moment resists rotor-furl motion, but it is a constant that is not proportional to the rotor-furl rate. However, if the rotor-furl rate is zero, the damping is zero. This value must not be negative and is only used when RFrIMod is set to 1. (N·m)

RFrIUSSP The rotor-furl up-stop spring is effective when the rotor-furl deflection exceeds this value. This value must be greater than -180 and less than or equal to 180 degrees and is only used when RFrIMod is set to 1. (deg)

RFrIDSSP The rotor-furl down-stop spring is effective when the rotor-furl deflection exceeds this value. This value must be greater than -180 and less than or equal to RFrIUSSP degrees and is only used when RFrIMod is set to 1. (deg)

RFrIUSSpr The linear rotor-furl up-stop spring restoring moment is proportional to the rotor-furl up-stop deflection by this constant and is effective when the rotor-furl deflection exceeds RFrIUSSP. This value must not be negative and is only used when RFrIMod is set to 1. (N·m/rad)

RFrIDSSpr The linear rotor-furl down-stop spring restoring moment is proportional to the rotor-furl down-stop deflection by this constant and is effective when the rotor-furl deflection exceeds RFrIDSSP. This value must not be negative and is only used when RFrIMod is set to 1. (N·m/rad)

RFrIUSDP The rotor-furl up-stop damper is effective when the rotor-furl deflection exceeds this value. This value must be greater than -180 and less than or equal to 180 degrees and is only used when RFrIMod is set to 1. (deg)

RFrIDSDP The rotor-furl down-stop damper is effective when the rotor-furl deflection exceeds this value. This value must be greater than -180 and less than or equal to RFrIUSDP degrees and is only used when RFrIMod is set to 1. (deg)

RFrIUSDmp The linear rotor-furl up-stop damping moment is proportional to the rotor-furl rate by this constant and is effective when the rotor-furl deflection exceeds RFrIUSDP. This value must not be negative and is only used when RFrIMod is set to 1. (N·m/(rad/sec))

RFrIDSDmp The linear rotor-furl down-stop damping restoring moment is proportional to the rotor-furl rate by this constant and is effective when the rotor-furl deflection exceeds RFrIDSDP. This value must not be negative and is only used when RFrIMod is set to 1. (N·m/(rad/sec))

Table 13. Furling-Input-File Parameters (continued).

Tail-Furl

TFrIMod	The tail-furl springs and dampers can be modeled three ways. For a value of 0 for TFrIMod, there will be no tail-furl spring nor damper and the moment normally produced will be set to zero. A TFrIMod of 1 will invoke simple spring and damper models using the inputs provided below as appropriate coefficients. If you set TFrIMod to 2, FAST will call the routine UserTFrI() to compute the tail-furl spring and damper moments. You should replace the dummy routine supplied with the code with your own, which will need to be linked with the rest of FAST. Using values other than 0, 1, or 2 will cause FAST to abort. (switch)
TFrISpr	The linear tail-furl spring restoring moment is proportional to the tail-furl deflection through this constant. This value must not be negative and is only used when TFrIMod is set to 1. (N·m/rad)
TFrIDmp	The linear tail-furl damping moment is proportional to the tail-furl rate through this constant. This value must not be negative and is only used when TFrIMod is set to 1. (N·m/(rad/sec))
TFrICDmp	This Coulomb-friction damping moment resists tail-furl motion, but it is a constant that is not proportional to the tail-furl rate. However, if the tail-furl rate is zero, the damping is zero. This value must not be negative and is only used when TFrIMod is set to 1. (N·m)
TFrIUSSP	The tail-furl up-stop spring is effective when the tail-furl deflection exceeds this value. This value must be greater than -180 and less than or equal to 180 degrees and is only used when TFrIMod is set to 1. (deg)
TFrIDSSP	The tail-furl down-stop spring is effective when the tail-furl deflection exceeds this value. This value must be greater than -180 and less than or equal to TFrIUSSP degrees and is only used when TFrIMod is set to 1. (deg)
TFrIUSSpr	The linear tail-furl up-stop spring restoring moment is proportional to the tail-furl up-stop deflection by this constant and is effective when the tail-furl deflection exceeds TFrIUSSP. This value must not be negative and is only used when TFrIMod is set to 1. (N·m/rad)
TFrIDSSpr	The linear tail-furl down-stop spring restoring moment is proportional to the tail-furl down-stop deflection by this constant and is effective when the tail-furl deflection exceeds TFrIDSSP. This value must not be negative and is only used when TFrIMod is set to 1. (N·m/rad)
TFrIUSDP	The tail-furl up-stop damper is effective when the tail-furl deflection exceeds this value. This value must be greater than -180 and less than or equal to 180 degrees and is only used when TFrIMod is set to 1. (deg)
TFrIDSDP	The tail-furl down-stop damper is effective when the tail-furl deflection exceeds this value. This value must be greater than -180 and less than or equal to TFrIUSDP degrees and is only used when TFrIMod is set to 1. (deg)
TFrIUSDmp	The linear tail-furl up-stop damping moment is proportional to the tail-furl rate by this constant and is effective when the tail-furl deflection exceeds TFrIUSDP. This value must not be negative and is only used when TFrIMod is set to 1. (N·m/(rad/sec))
TFrIDSDmp	The linear tail-furl down-stop damping restoring moment is proportional to the tail-furl rate by this constant and is effective when the tail-furl deflection exceeds TFrIDSDP. This value must not be negative and is only used when TFrIMod is set to 1. (N·m/(rad/sec))

Table 13. Furling-Input-File Parameters (concluded).

Tail Fin Aerodynamics

TFinMod	The tail fin aerodynamics can be modeled three ways. For a value of 0 for TFinMod, there will be no tail fin aerodynamics and the aerodynamic loads normally produced will be set to zero. A TFinMod of 1 will invoke a simplified tail fin aerodynamics model using the inputs provided below as appropriate parameters. If you set TFinMod to 2, FAST will call the routine UserTFin() to compute the tail fin aerodynamic loads. You should replace the dummy routine supplied with the code with your own, which will need to be linked with the rest of FAST. Using values other than 0, 1, or 2 will cause FAST to abort. (switch)
TFinNFoil	This integer tells AeroDyn which of the input airfoil files (FoilNm) is assigned to the tail fin. For instance, a value of 2 means that the tail fin will use FoilNm ₂ for the local tail fin airfoil. The tail fin airfoil may be assigned to the same airfoil as one or more blade stations. This value must be between 1 and NumFoil and is only used when TFinMod is set to 1. (-)
TFinArea	This is the plan form area of the tail fin plate used to relate the local dynamic pressure and airfoil coefficients to aerodynamic loads. This value must not be negative and is only used when TFinMod is set to 1. (m ²)
SubAxInd	Set this value to False if you want the wind velocity at the tail fin to be unobstructed by the rotor wake. Set this value to True if you want FAST to decrease (i.e., subtract) the wind velocity at the tail fin center-of-pressure in the rotor shaft direction by the average rotor axial induction. This input is only used when TFinMod is set to 1. (flag)

Table 14. ADAMS-Specific-Input-File Parameters.

The following input parameters are contained in the file indicated by input `ADAMSFile` from the primary input file. FAST will only read this file if the FAST-to-ADAMS preprocessor is enabled (when `ADAMSPrep` from the primary input file is set to 2 or 3).

Feature Flags

- SaveGrphcs** If set to True, this flag tells ADAMS to generate a graphics output file for viewing an animation of the ADAMS simulation. Set this to False if you don't want graphics output generated; this saves a lot of hard disk space if the simulation is long. (flag)
- MakeLINacf** If set to True, this flag tells FAST to generate an ADAMS control/command file used to drive an ADAMS/LINEAR eigenanalysis of the model. The eigenanalysis is performed with no gravity, rotor speed, damping, or aerodynamics, no matter how the associated inputs are otherwise specified in FAST's other input file(s). Set to False if you don't want this additional control/command file generated. **SaveGrphcs** must be True if this input is True. (flag)

Damping Parameters

- CRatioTGJ** This is the ratio of the tower's torsional damping to stiffness in ADAMS. A typical value is 0.01 and it must not be negative. (-)
- CRatioTEA** This is the ratio of the tower's extensional damping to stiffness in ADAMS. A typical value is 0.01 and it must not be negative. (-)
- CRatioBGJ** This is the ratio of a blade's torsional damping to stiffness in ADAMS. A typical value is 0.01 and it must not be negative. The same ratio is used for all blades. (-)
- CRatioBEA** This is the ratio of a blade's extensional damping to stiffness in ADAMS. A typical value is 0.01 and it must not be negative. The same ratio is used for all blades. (-)

Blade Pitch Actuator Parameters

- BPActrSpr** This is the torsional spring stiffness of the blade pitch actuators in ADAMS. The linear blade pitch spring moment is proportional to the pitch error through this constant. If a pitch actuator natural frequency is known in place of an actuator spring stiffness, compute the spring stiffness as follows: $BPActrSpr = PitchIner \cdot \omega_n^2$, where ω_n is the natural frequency in rad/sec and $PitchIner$ is the nominal inertia of the blade about the pitch axis in $kg \cdot m^2$. The same stiffness is used for all blade pitch actuators and it must not be negative. (N·m/rad)
- BPActrDmp** This is the torsional damping constant of the blade pitch actuators in ADAMS. The linear blade pitch damping moment is proportional to the blade pitch rate through this constant. If a pitch actuator natural frequency and damping ratio are known in place of an actuator damping constant, compute the damping constant as follows: $BPActrDmp = 2 \cdot \zeta \cdot PitchIner \cdot \omega_n$, where ω_n is the natural frequency in rad/sec, ζ is the damping ratio in fraction of critical, and $PitchIner$ is the nominal inertia of the blade about the pitch axis in $kg \cdot m^2$. The same damping is used for all blade pitch actuators and it must not be negative. (N·m/(rad/sec))

GRAPHICS Parameters

- NSides** This is the number of line segments ADAMS includes when drawing GRAPHICS cylinder and frustum statements in graphical output. This value must not be negative. (-)
- TwrBaseRad** This is the radius of the tower base (at elevation `TwrRBHt` above base of the tower). It is used to define GRAPHICS cylinders for depicting the linearly tapered tower in ADAMS' graphical output. This value must not be negative. (m)
- TwrTopRad** This is the radius of the tower-top (at elevation `TowerHt`). It is used to define GRAPHICS cylinders for depicting the linearly tapered tower in ADAMS' graphical output. This value must not be negative. (m)

Table 14. ADAMS-Specific-Input-File Parameters (concluded).

GRAPHICS Parameters (concluded)

NacLength	This is the length of the nacelle. It is used to define the nacelle GRAPHICS frustum statement for ADAMS' graphical output. The nacelle GRAPHICS is centered about the point of intersection between the rotor shaft axis and the y_n - Z_n -plane. This value must not be negative or larger than twice the magnitude of OverHang. (m)
NacRadBot	This is the radius of the bottom of the nacelle (opposite side of rotor). It is used to define the nacelle GRAPHICS frustum statement for ADAMS' graphical output. This value must not be negative. (m)
NacRadTop	This is the radius of the top of the nacelle (same side as rotor). It is used to define the nacelle GRAPHICS frustum statement for ADAMS' graphical output. This value must not be negative. (m)
GBoxLength	This is the length, width, and height of a cube depicting the gearbox in ADAMS' graphical output. It is used to define the gearbox GRAPHICS box statement. The gearbox GRAPHICS is centered about the point of intersection between the low- and high-speed shafts. This value must not be negative. (m)
GenLength	This is the length of the generator. It is used to define the length of a GRAPHICS cylinder depicting the generator. The generator GRAPHICS extends from the end of the HSS. This value must not be negative. (m)
HSSLength	This is the length of the HSS. It is used to define the length of a GRAPHICS cylinder depicting the HSS. The HSS GRAPHICS extends from the end of the LSS. The generator GRAPHICS originates at the end of the HSS opposite the rotor. This value must not be negative. (m)
LSSLength	This is the length of the LSS. It is used to define the length of a GRAPHICS cylinder depicting the LSS. The LSS GRAPHICS extends toward the tower from the teeter pin for two-bladed turbines or from the rotor apex for three-bladed turbines. The HSS GRAPHICS originates at the end of the LSS opposite the rotor. This value must not be negative. (m)
GenRad	This is the radius of the generator. It is used to define the radius of a GRAPHICS cylinder depicting the generator for ADAMS' graphical output. This value must not be negative. (m)
HSSRad	This is the radius of the HSS. It is used to define the radius of a GRAPHICS cylinder depicting the HSS for ADAMS' graphical output. This value must not be negative. (m)
LSSRad	This is the radius of the LSS. It is used to define the radius of a GRAPHICS cylinder depicting the LSS for ADAMS' graphical output. This value must not be negative. (m)
HubCylRad	This is the radius of the cylinder depicting the hub in ADAMS' graphical output. It is used in the hub GRAPHICS cylinder statements, which extend from the apex of the cone of rotation to the blade roots along the pitch axes. This value must not be negative. (m)
ThkOvrChrd	This is the ratio of blade thickness to blade chord for depicting the blade elements in ADAMS' graphical output. It is used in the blade element GRAPHICS box statements. The same value is used for each blade element of each blade and must not be negative. (m)
BoomRad	This is the radius of the tail boom. It is used to define the radius of a GRAPHICS cylinder depicting the tail boom for ADAMS' graphical output. The tail boom GRAPHICS extends from the specified point on the tail-furl axis (characterized by inputs TFrlPntxn, TFrlPnty, and TFrlPntzn) to a point just below the tail fin center-of-pressure. This value must not be negative. (m)

Table 15. Linearization Control-Input-File Parameters.

The following input parameters are contained in the file indicated by input `LinFile` from the primary input file. FAST will only read this file when a linearization is performed (when `AnalMode` from the primary input file is set to 2).

Periodic Steady State Solution

<code>CalcStdy</code>	This flag determines whether a periodic steady state solution is computed before linearizing the model. If <code>False</code> , the next three inputs are ignored and the linearization occurs about the initial conditions specified in FAST's primary input file. That is, when <code>CalcStdy</code> is <code>False</code> , the operating point is set to the condition in which all displacements, velocities, and accelerations are zero, except those specified with nonzero initial conditions (for instance, the azimuth DOF will increment at a constant rate if and when the rotor is spinning). If <code>CalcStdy</code> is <code>True</code> and <code>RotSpeed</code> is nonzero, FAST integrates in time until a periodic steady state solution is reached. The method of solution is determined by the next input, <code>TrimCase</code> . FAST is then linearized about this periodic operating point. If <code>CalcStdy</code> is <code>True</code> and <code>RotSpeed</code> is zero, FAST will disable <code>GenDOF</code> (if previously enabled) and integrate in time until a static equilibrium position is found. FAST is then linearized about this position. The accuracy of the steady state solution is determined through input convergence tolerances <code>DispTol</code> and <code>VelTol</code> (see below). This input is not used in the FAST-to-ADAMS preprocessor. (flag)
<code>TrimCase</code>	This switch determines, for a variable speed machine, which control input to trim in order to reach the desired azimuth-averaged rotor speed indicated through input <code>RotSpeed</code> (which is also the initial rotor speed). Setting it to 1 causes FAST to trim nacelle yaw command (demand) angle, while maintaining constant rotor collective blade pitch (indicated by inputs <code>BIPitch_i</code>), to reach the desired azimuth-averaged rotor speed. With yaw DOF enabled (<code>YawDOF = True</code>), the nacelle yaw command is the neutral yaw angle, <code>YawNeut</code> , which is passed through FAST's built-in, second-order actuator model. With yaw DOF disabled (<code>YawDOF = False</code>), the nacelle yaw command is the actual nacelle yaw angle. Setting <code>TrimCase</code> to 2 causes FAST to trim electrical generator torque, while maintaining constant rotor collective blade pitch (indicated by inputs <code>BIPitch_i</code>), to reach the desired azimuth-averaged rotor speed (i.e., Region 2 trim). Setting <code>TrimCase</code> to 3 causes FAST to trim rotor collective blade pitch to reach the desired azimuth-averaged rotor speed (i.e., Region 3 trim). In this case, the initial "guess" blade pitch angles are given by <code>BIPitch_i</code> and the electrical generator torque is determined by the torque-speed relationship indicated by inputs <code>VSContrl</code> or <code>GenModel</code> . For typical Region 3 trim, collective pitch can be trimmed while maintaining a constant generator torque by setting <code>TrimCase</code> to 3, <code>VSContrl</code> to 1, <code>VS_RtTq</code> to the desired constant generator torque, and <code>VS_RtGnSp</code> , <code>VS_Rgn2K</code> , and <code>VS_SIPc</code> to 9999.9E-9 (very small don't cares > 0.0). Input parameter <code>TrimCase</code> is ignored when either <code>CalcStdy</code> or <code>GenDOF</code> is <code>False</code> . For a constant speed machine, <code>GenDOF</code> should be set to <code>False</code> when linearizing FAST, in which case, input <code>TrimCase</code> is ignored. Using values other than 1, 2, or 3 will cause FAST to abort. This input is not used in the FAST-to-ADAMS preprocessor. (switch)
<code>DispTol</code>	This is the convergence tolerance for the 2-norm of angular displacements in the calculation of periodic steady state solution. The steady state solution is found when this tolerance and <code>VelTol</code> are both met. The smaller the number, the tighter the tolerance is. This input is ignored if <code>CalcStdy</code> is <code>False</code> . This input is not used in the FAST-to-ADAMS preprocessor. (rad)
<code>VelTol</code>	This is the convergence tolerance for the 2-norm of angular velocities in the calculation of the periodic steady state solution. The steady state solution is found when this tolerance and <code>DispTol</code> are both met. The smaller the number, the tighter the tolerance is. This input is ignored if <code>CalcStdy</code> is <code>False</code> . This input is not used in the FAST-to-ADAMS preprocessor. (rad/s)

Table 15. Linearization Control-Input-File Parameters (concluded).

Model Linearization

NAzimStep	This is the number of equally spaced rotor azimuth steps in the output periodic linearized model. The first rotor azimuth location is always the initial azimuth position indicated by inputs Azimuth and AzimB1Up . The subsequent azimuth steps increment in the direction of rotation. If RotSpeed is zero, FAST will override NAzimStep and only linearize the model about the initial azimuth position (as if NAzimStep was set to 1). This input is not used in the FAST-to-ADAMS preprocessor. (-)
MdlOrder	This is the order of the output linearized model. A setting of 1 causes FAST to output the first-order representation of the linearized model. A setting of 2 causes FAST to output the second-order representation of the linearized model. Using values other than 1 or 2 will cause FAST to abort. This input is not used in the FAST-to-ADAMS preprocessor. (-)

Inputs and Disturbances

NInputs	The number of control inputs indicates the number of input values on the next line. Valid values are integers from 0 to 4 + NumBl (inclusive). This input is not used in the FAST-to-ADAMS preprocessor. (-)
CntrlInpt	This is a list of numbers corresponding to different types of control inputs. Possible values are 1 to 7 (inclusive) (7 is only available if NumBl = 3). The numbers correspond to seven control inputs as follows: (1) nacelle yaw angle command, (2) nacelle yaw rate command, (3) electrical generator torque, (4) rotor collective blade pitch, (5) individual pitch of blade 1, (6) individual pitch of blade 2, and (7) individual pitch of blade 3 (unavailable if NumBl = 2). If the yaw DOF is enabled (YawDOF = True), then the commanded yaw angle and rate from CntrlInpt setting 1 and 2 are the neutral yaw angle, YawNeut , and neutral yaw rate, YawRateNeut , in FAST's built-in second-order actuator model. In this case, the yaw actuator, which is described in the Nacelle Yaw Control section of the Controls chapter, will be inherent in the output linearized model. If the yaw DOF is disabled (YawDOF = False), then the commanded yaw angle and rate from CntrlInpt setting 1 and 2 are the actual yaw angle and yaw rate. In this case, the yaw actuator will be absent from the output linearized model. You must enter at least Ninputs values on the line of input CntrlInpt . If Ninputs is 0, this line will be skipped, but you must have a line taking up space in the input file. You can separate the values with combinations of tabs, spaces, and commas, but you may use only one comma between numbers. This input is not used in the FAST-to-ADAMS preprocessor. (-)
NDisturbs	The number of wind input disturbances indicates the number of input values on the next line. Valid values are integers from 0 to 7 (inclusive). This input is not used in the FAST-to-ADAMS preprocessor. (-)
Disturbnc	This is a list of numbers corresponding to different types of wind input disturbances. Possible values are 1 to 7 (inclusive). The numbers correspond to the seven inputs available in the hub-height wind data files of AeroDyn as follows: (1) horizontal hub-height wind speed, V , (2) horizontal wind direction, DELTA , (3) vertical wind speed, VZ , (4) horizontal wind shear, HSHR , (5) vertical power law wind shear, VSHR , (6) linear vertical wind shear, VLinSHR , and (7) horizontal hub-height wind gust, VG . You must enter at least NDisturbs values on this line. If NDisturbs is 0, this line will be skipped, but you must have a line taking up space in the input file. You can separate the values with combinations of tabs, spaces, and commas, but you may use only one comma between numbers. This input is not used in the FAST-to-ADAMS preprocessor. (-)

OUTPUT FILES

The program generates one or more output files based on settings in the input file.

For time-marching analyses, the primary output file contains columns of time-series data with one column for each parameter that is requested in the primary input file. The name of this file uses the path and root name of the primary input file and appends *.out* for an extension. For example, if the input file were named *fast.fst*, the main output file will be named *fast.out*. The available output parameters are shown in Table 16 through Table 44 and are also documented in the *OutList.txt* file of the FAST archive. An example output file is shown in Figure 30.

In some situations, some output channels are meaningless. For instance, if aerodynamic calculations are disabled, parameters such as the wind speed are invalid. You can still leave those parameters in your output list, but the data generated will be all zeros. The name and units for the channel will also be replaced with “INVALID” and “CHANNEL” respectively. Output loads and motions follow the IEC system. Please refer to Figure 3 through Figure 9 to get a sense for which directions are positive.

For linearization analyses, the primary output file provides the periodic state matrices of the linearized model. The name of this file uses the path and root name of the primary input file and appends *.lin* for an extension. For example, if the input file were named *fast.fst*, the main output file will be named *fast.lin*. An example linearized model file is shown in Figure 31.

If the **SumPrint** flag is set to True, FAST generates a second output file, with a *.fsm* for an extension. In the above example, this file will be

named *fast.fsm*. This file contains some of the basic input file parameters and computed inertia properties of the blades and tower. An example summary file is shown in Figure 32.

If the **SumPrint** flag is set to True, AeroDyn also generates a summary file that contains blade-element geometry data, airfoil data files at the corresponding blade element, and the summary of combined FAST/AeroDyn input parameters. In the above example, this file will be named *fast.opt*. An example of this AeroDyn output can be found in Figure 33.

If **ADAMSPrep** is set to 2 or 3, FAST generates ADAMS dataset files corresponding to the model configuration and analysis settings specified in the FAST input file(s). See the ADAMS Preprocessor chapter for a description of these output files.

A final file is generated only when the word “PRINT” is found on one or more of the lines defining the blade elements in the AeroDyn input file. This file contains a time series of aerodynamic data and has a *.elm* extension, as in, *fast.elm*. Please see the AeroDyn User’s Guide [1] for details on this file.

When running FAST within Simulink, the output file names use the root name of the primary input file and append *_SFunc* to the name. For example, if the primary input file were named *fast.fst*, the main output file from the FAST S-Function will be named *fast_SFunc.out* whereas the the FAST executable would generate *fast.out*. Please see the Simulink Interface chapter for further details.

Table 16. Output Parameters for Wind Motions.

Name	Other Name(s)	Description	Convention	Units
WindVxi	uWind	Nominally downwind component of the hub-height wind velocity (unavailable if CompAero is False)	Directed along the x_i -axis	(m/sec)
WindVyi	vWind	Cross-wind component of the hub-height wind velocity (unavailable if CompAero is False)	Directed along the y_i -axis	(m/sec)
WindVzi	wWind	Vertical component of the hub-height wind velocity (unavailable if CompAero is False)	Directed along the z_i -axis	(m/sec)
TotWindV		Total hub-height wind speed magnitude (unavailable if CompAero is False)	N/A	(m/sec)
HorWindV		Horizontal hub-height wind speed magnitude (unavailable if CompAero is False)	In the x_i - and y_i -plane	(m/sec)
HorWndDir		Horizontal hub-height wind direction. Please note that FAST uses the opposite of the sign convention that AeroDyn uses. Put a “-”, “_”, “m”, or “M” character in front of this variable name in the input file to change its sign if you want to use the AeroDyn convention. (unavailable if CompAero is False)	About the z_i -axis	(deg)
VerWndDir		Vertical hub-height wind direction (unavailable if CompAero is False)	About an axis orthogonal to the z_i -axis and the HorWindV -vector	(deg)

Table 17. Output Parameters for Blade 1 Tip Motions.

Name	Other Name(s)	Description	Convention	Units
TipDxc1	OoPDefl1	Blade 1 out-of-plane tip deflection (relative to the pitch axis)	Directed along the $x_{c,1}$ -axis	(m)
TipDyc1	IPDefl1	Blade 1 in-plane tip deflection (relative to the pitch axis)	Directed along the $y_{c,1}$ -axis	(m)
TipDzc1	TipDzb1	Blade 1 axial tip deflection (relative to the pitch axis)	Directed along the $z_{c,1}$ - and $z_{b,1}$ -axes	(m)
TipDxb1		Blade 1 flapwise tip deflection (relative to the pitch axis)	Directed along the $x_{b,1}$ -axis	(m)
TipDyb1		Blade 1 edgewise tip deflection (relative to the pitch axis)	Directed along the $y_{b,1}$ -axis	(m)
TipALxb1		Blade 1 <i>local</i> flapwise tip acceleration (absolute)	Directed along the <i>local</i> $x_{b,1}$ -axis	(m/sec ²)
TipALyb1		Blade 1 <i>local</i> edgewise tip acceleration (absolute)	Directed along the <i>local</i> $y_{b,1}$ -axis	(m/sec ²)
TipALzb1		Blade 1 <i>local</i> axial tip acceleration (absolute)	Directed along the <i>local</i> $z_{b,1}$ -axis	(m/sec ²)
TipRDxb1	RollDefl1	Blade 1 roll (angular/rotational) tip deflection (relative to the undeflected position). In ADAMS, it is output as an Euler angle computed as the 3 rd rotation in the yaw-pitch-roll rotation sequence. It is not output as an Euler angle in FAST, which assumes small blade deflections, so that the rotation sequence does not matter.	About the $x_{b,1}$ -axis	(deg)
TipRDyb1	PtchDefl1	Blade 1 pitch (angular/rotational) tip deflection (relative to the undeflected position). In ADAMS, it is output as an Euler angle computed as the 2 nd rotation in the yaw-pitch-roll rotation sequence. It is not output as an Euler angle in FAST, which assumes small blade deflections, so that the rotation sequence does not matter.	About the $y_{b,1}$ -axis	(deg)
TipRDzc1	TipRDzb1 TwstDefl1	Blade 1 torsional tip deflection (relative to the undeflected position). This output will always be zero for FAST simulation results. Use it for examining blade torsional deflections of ADAMS simulations run using ADAMS datasets created using the FAST-to-ADAMS preprocessor. In ADAMS, it is output as an Euler angle computed as the 1 st rotation in the yaw-pitch-roll rotation sequence. Please note that this output uses the opposite of the sign convention used for blade pitch angles.	About the $z_{c,1}$ - and $z_{b,1}$ -axes	(deg)
TipClrnc1	TwrClrnc1 Tip2Twr1	Blade 1 tip-to-tower clearance estimate. This is computed as the perpendicular distance from the yaw axis to the tip of blade 1 when the blade tip is below the yaw bearing. When the tip of blade 1 is above the yaw bearing, it is computed as the absolute distance from the yaw bearing to the blade tip. Please note that you should reduce this value by the tower radius to obtain the actual tower clearance.	N/A	(m)

Table 18. Output Parameters for Blade 2* Tip Motions.

Name	Other Name(s)	Description	Convention	Units
TipDxc2	OoPDefl2	Blade 2 out-of-plane tip deflection (relative to the pitch axis)	Directed along the $x_{c,2}$ -axis	(m)
TipDyc2	IPDefl2	Blade 2 in-plane tip deflection (relative to the pitch axis)	Directed along the $y_{c,2}$ -axis	(m)
TipDzc2	TipDzb2	Blade 2 axial tip deflection (relative to the pitch axis)	Directed along the $z_{c,2}$ - and $z_{b,2}$ -axes	(m)
TipDxb2		Blade 2 flapwise tip deflection (relative to the pitch axis)	Directed along the $x_{b,2}$ -axis	(m)
TipDyb2		Blade 2 edgewise tip deflection (relative to the pitch axis)	Directed along the $y_{b,2}$ -axis	(m)
TipALxb2		Blade 2 <i>local</i> flapwise tip acceleration (absolute)	Directed along the <i>local</i> $x_{b,2}$ -axis	(m/sec ²)
TipALyb2		Blade 2 <i>local</i> edgewise tip acceleration (absolute)	Directed along the <i>local</i> $y_{b,2}$ -axis	(m/sec ²)
TipALzb2		Blade 2 <i>local</i> axial tip acceleration (absolute)	Directed along the <i>local</i> $z_{b,2}$ -axis	(m/sec ²)
TipRDxb2	RollDefl2	Blade 2 roll (angular/rotational) tip deflection (relative to the undeflected position). In ADAMS, it is output as an Euler angle computed as the 3 rd rotation in the yaw-pitch-roll rotation sequence. It is not output as an Euler angle in FAST, which assumes small blade deflections, so that the rotation sequence does not matter.	About the $x_{b,2}$ -axis	(deg)
TipRDyb2	PtchDefl2	Blade 2 pitch (angular/rotational) tip deflection (relative to the undeflected position). In ADAMS, it is output as an Euler angle computed as the 2 nd rotation in the yaw-pitch-roll rotation sequence. It is not output as an Euler angle in FAST, which assumes small blade deflections, so that the rotation sequence does not matter.	About the $y_{b,2}$ -axis	(deg)
TipRDzc2	TipRDzb2 TwstDefl2	Blade 2 torsional tip deflection (relative to the undeflected position). This output will always be zero for FAST simulation results. Use it for examining blade torsional deflections of ADAMS simulations run using ADAMS datasets created using the FAST-to-ADAMS preprocessor. In ADAMS, it is output as an Euler angle computed as the 1 st rotation in the yaw-pitch-roll rotation sequence. Please note that this output uses the opposite of the sign convention used for blade pitch angles.	About the $z_{c,2}$ - and $z_{b,2}$ -axes	(deg)
TipClrnc2	TwrClrnc2 Tip2Twr2	Blade 2 tip-to-tower clearance estimate. This is computed as the perpendicular distance from the yaw axis to the tip of blade 2 when the blade tip is below the yaw bearing. When the tip of blade 2 is above the yaw bearing, it is computed as the absolute distance from the yaw bearing to the blade	N/A	(m)

* For three-bladed rotors, blade 3 is ahead of blade 2, which is ahead of blade 1, so that the order of blades passing through a given azimuth is 3-2-1-repeat.

Name	Other Name(s)	Description	Convention	Units
		tip. Please note that you should reduce this value by the tower radius to obtain the actual tower clearance.		

Table 19. Output Parameters for Blade 3* Tip Motions.

Name	Other Name(s)	Description	Convention	Units
TipDxc3	OoPDefl3	Blade 3 out-of-plane tip deflection (relative to the pitch axis) (unavailable for two-bladed turbines)	Directed along the $x_{c,3}$ -axis	(m)
TipDyc3	IPDefl3	Blade 3 in-plane tip deflection (relative to the pitch axis) (unavailable for two-bladed turbines)	Directed along the $y_{c,3}$ -axis	(m)
TipDzc3	TipDzb3	Blade 3 axial tip deflection (relative to the pitch axis) (unavailable for two-bladed turbines)	Directed along the $z_{c,3}$ - and $z_{b,3}$ -axes	(m)
TipDxb3		Blade 3 flapwise tip deflection (relative to the pitch axis) (unavailable for two-bladed turbines)	Directed along the $x_{b,3}$ -axis	(m)
TipDyb3		Blade 3 edgewise tip deflection (relative to the pitch axis) (unavailable for two-bladed turbines)	Directed along the $y_{b,3}$ -axis	(m)
TipALxb3		Blade 3 <i>local</i> flapwise tip acceleration (absolute) (unavailable for two-bladed turbines)	Directed along the <i>local</i> $x_{b,3}$ -axis	(m/sec ²)
TipALyb3		Blade 3 <i>local</i> edgewise tip acceleration (absolute) (unavailable for two-bladed turbines)	Directed along the <i>local</i> $y_{b,3}$ -axis	(m/sec ²)
TipALzb3		Blade 3 <i>local</i> axial tip acceleration (absolute) (unavailable for two-bladed turbines)	Directed along the <i>local</i> $z_{b,3}$ -axis	(m/sec ²)
TipRDxb3	RollDefl3	Blade 3 roll (angular/rotational) tip deflection (relative to the undeflected position). In ADAMS, it is output as an Euler angle computed as the 3 rd rotation in the yaw-pitch-roll rotation sequence. It is not output as an Euler angle in FAST, which assumes small blade deflections, so that the rotation sequence does not matter. (unavailable for two-bladed turbines)	About the $x_{b,3}$ -axis	(deg)
TipRDyb3	PtchDefl3	Blade 3 pitch (angular/rotational) tip deflection (relative to the undeflected position). In ADAMS, it is output as an Euler angle computed as the 2 nd rotation in the yaw-pitch-roll rotation sequence. It is not output as an Euler angle in FAST, which assumes small blade deflections, so that the rotation sequence does not matter. (unavailable for two-bladed turbines)	About the $y_{b,3}$ -axis	(deg)
TipRDzc3	TipRDzb3 TwstDefl3	Blade 3 torsional tip deflection (relative to the undeflected position). This output will always be zero for FAST simulation results. Use it for examining blade torsional deflections of ADAMS simulations run using ADAMS datasets created using the FAST-to-ADAMS preprocessor. In ADAMS, it is output as an Euler angle computed as the 1 st rotation in the yaw-pitch-roll rotation sequence. Please note that this output uses the opposite of the sign convention used for blade pitch angles. (unavailable for two-bladed turbines)	About the $z_{c,3}$ - and $z_{b,3}$ -axes	(deg)
TipClrnc3	TwrClrnc3 Tip2Twr3	Blade 3 tip-to-tower clearance estimate. This is computed as the perpendicular distance from the yaw axis to the tip of blade 3 when the blade tip is	N/A	(m)

* For three-bladed rotors, blade 3 is ahead of blade 2, which is ahead of blade 1, so that the order of blades passing through a given azimuth is 3-2-1-repeat.

Name	Other Name(s)	Description	Convention	Units
		below the yaw bearing. When the tip of blade 3 is above the yaw bearing, it is computed as the absolute distance from the yaw bearing to the blade tip. Please note that you should reduce this value by the tower radius to obtain the actual tower clearance. (unavailable for two-bladed turbines)		

Table 20. Output Parameters for Blade 1 Local Span Motions*

Name	Other Name(s)	Description	Convention	Units
Spn1ALxb1		Blade 1 <i>local</i> flapwise acceleration (absolute) of span station 1 (unavailable if NBIGages = 0)	Directed along the <i>local</i> $x_{b,1}$ -axis	(m/sec ²)
Spn1ALyb1		Blade 1 <i>local</i> edgewise acceleration (absolute) of span station 1 (unavailable if NBIGages = 0)	Directed along the <i>local</i> $y_{b,1}$ -axis	(m/sec ²)
Spn1ALzb1		Blade 1 <i>local</i> axial acceleration (absolute) of span station 1 (unavailable if NBIGages = 0)	Directed along the <i>local</i> $z_{b,1}$ -axis	(m/sec ²)
Spn2ALxb1		Blade 1 <i>local</i> flapwise acceleration (absolute) of span station 2 (unavailable if NBIGages < 2)	Directed along the <i>local</i> $x_{b,1}$ -axis	(m/sec ²)
Spn2ALyb1		Blade 1 <i>local</i> edgewise acceleration (absolute) of span station 2 (unavailable if NBIGages < 2)	Directed along the <i>local</i> $y_{b,1}$ -axis	(m/sec ²)
Spn2ALzb1		Blade 1 <i>local</i> axial acceleration (absolute) of span station 2 (unavailable if NBIGages < 2)	Directed along the <i>local</i> $z_{b,1}$ -axis	(m/sec ²)
Spn3ALxb1		Blade 1 <i>local</i> flapwise acceleration (absolute) of span station 3 (unavailable if NBIGages < 3)	Directed along the <i>local</i> $x_{b,1}$ -axis	(m/sec ²)
Spn3ALyb1		Blade 1 <i>local</i> edgewise acceleration (absolute) of span station 3 (unavailable if NBIGages < 3)	Directed along the <i>local</i> $y_{b,1}$ -axis	(m/sec ²)
Spn3ALzb1		Blade 1 <i>local</i> axial acceleration (absolute) of span station 3 (unavailable if NBIGages < 3)	Directed along the <i>local</i> $z_{b,1}$ -axis	(m/sec ²)
Spn4ALxb1		Blade 1 <i>local</i> flapwise acceleration (absolute) of span station 4 (unavailable if NBIGages < 4)	Directed along the <i>local</i> $x_{b,1}$ -axis	(m/sec ²)
Spn4ALyb1		Blade 1 <i>local</i> edgewise acceleration (absolute) of span station 4 (unavailable if NBIGages < 4)	Directed along the <i>local</i> $y_{b,1}$ -axis	(m/sec ²)
Spn4ALzb1		Blade 1 <i>local</i> axial acceleration (absolute) of span station 4 (unavailable if NBIGages < 4)	Directed along the <i>local</i> $z_{b,1}$ -axis	(m/sec ²)
Spn5ALxb1		Blade 1 <i>local</i> flapwise acceleration (absolute) of span station 5 (unavailable if NBIGages < 5)	Directed along the <i>local</i> $x_{b,1}$ -axis	(m/sec ²)
Spn5ALyb1		Blade 1 <i>local</i> edgewise acceleration (absolute) of span station 5 (unavailable if NBIGages < 5)	Directed along the <i>local</i> $y_{b,1}$ -axis	(m/sec ²)
Spn5ALzb1		Blade 1 <i>local</i> axial acceleration (absolute) of span station 5 (unavailable if NBIGages < 5)	Directed along the <i>local</i> $z_{b,1}$ -axis	(m/sec ²)

* These motions are for the nodes you specify with the BldGagNd input array.

Table 21. Output Parameters for Blade Pitch Motions.

Name	Other Name(s)	Description	Convention	Units
PtchPMzc1	PtchPMzb1 BldPitch1 BIPitch1	Blade 1 pitch angle (position)	Positive towards feather about the <i>minus</i> $Z_{c,1}$ - and <i>minus</i> $Z_{b,1}$ -axes	(deg)
PtchPMzc2	PtchPMzb2 BldPitch2 BIPitch2	Blade 2 pitch angle (position)	Positive towards feather about the <i>minus</i> $Z_{c,2}$ - and <i>minus</i> $Z_{b,2}$ -axes	(deg)
PtchPMzc3	PtchPMzb3 BldPitch3 BIPitch3	Blade 3 pitch angle (position) (unavailable for two-bladed turbines)	Positive towards feather about the <i>minus</i> $Z_{c,3}$ - and <i>minus</i> $Z_{b,3}$ -axes	(deg)

Table 22. Output Parameters for Teeter Motions.

Name	Other Name(s)	Description	Convention	Units
TeetPya	RotTeetP TeetDefl	Rotor teeter angle (position) (unavailable for three-bladed turbines)	About the y_a -axis	(deg)
TeetVya	RotTeetV	Rotor teeter angular velocity (unavailable for three-bladed turbines)	About the y_a -axis	(deg/sec)
TeetAya	RotTeetA	Rotor teeter angular acceleration (unavailable for three-bladed turbines)	About the y_a -axis	(deg/sec ²)

* For three-bladed rotors, blade 3 is ahead of blade 2, which is ahead of blade 1, so that the order of blades passing through a given azimuth is 3-2-1-repeat.

Table 23. Output Parameters for Shaft Motions.

Name	Other Name(s)	Description	Convention	Units
LSSTipPxa	LSSTipPxs LSSTipP Azimuth	Rotor azimuth angle (position)	About the x_a - and x_s -axes	(deg)
LSSTipVxa	LSSTipVxs LSSTipV RotSpeed	Rotor azimuth angular speed	About the x_a - and x_s -axes	(rpm)
LSSTipAxa	LSSTipAxs LSSTipA RotAccel	Rotor azimuth angular acceleration	About the x_a - and x_s -axes	(deg/sec ²)
LSSGagPxa	LSSGagPxs LSSGagP	LSS strain-gage azimuth angle (position) (on the gearbox side of the LSS)	About the x_a - and x_s -axes	(deg)
LSSGagVxa	LSSGagVxs LSSGagV	LSS strain-gage angular speed (on the gearbox side of the LSS)	About the x_a - and x_s -axes	(rpm)
LSSGagAxa	LSSGagAxs LSSGagA	LSS strain-gage angular acceleration (on the gearbox side of the LSS)	About the x_a - and x_s -axes	(deg/sec ²)
HSShftV	GenSpeed	Angular speed of the HSS and generator	Same sign as LSSGagVxa / LSSGagVxs / LSSGagV	(rpm)
HSShftA	GenAccel	Angular acceleration of the HSS and generator	Same sign as LSSGagAxa / LSSGagAxs / LSSGagA	(deg/sec ²)
TipSpdRat	TSR	Rotor blade tip speed ratio (unavailable if CompAero is False)	N/A	(-)

Table 24. Output Parameters for Nacelle Inertial Measurement Unit Motions*

Name	Other Name(s)	Description	Convention	Units
NcIMUTVxs		Nacelle inertial measurement unit translational velocity (absolute)	Directed along the x_s -axis	(m/sec)
NcIMUTVys		Nacelle inertial measurement unit translational velocity (absolute)	Directed along the y_s -axis	(m/sec)
NcIMUTVzs		Nacelle inertial measurement unit translational velocity (absolute)	Directed along the z_s -axis	(m/sec)
NcIMUTAxS		Nacelle inertial measurement unit translational acceleration (absolute)	Directed along the x_s -axis	(m/sec ²)
NcIMUTAyS		Nacelle inertial measurement unit translational acceleration (absolute)	Directed along the y_s -axis	(m/sec ²)
NcIMUTAzS		Nacelle inertial measurement unit translational acceleration (absolute)	Directed along the z_s -axis	(m/sec ²)
NcIMURVxs		Nacelle inertial measurement unit angular (rotational) velocity (absolute)	About the x_s -axis	(deg/sec)
NcIMURVys		Nacelle inertial measurement unit angular (rotational) velocity (absolute)	About the y_s -axis	(deg/sec)
NcIMURVzs		Nacelle inertial measurement unit angular (rotational) velocity (absolute)	About the z_s -axis	(deg/sec)
NcIMURAxS		Nacelle inertial measurement unit angular (rotational) acceleration (absolute)	About the x_s -axis	(deg/sec ²)
NcIMURAyS		Nacelle inertial measurement unit angular (rotational) acceleration (absolute)	About the y_s -axis	(deg/sec ²)
NcIMURAzS		Nacelle inertial measurement unit angular (rotational) acceleration (absolute)	About the z_s -axis	(deg/sec ²)

* The location of the nacelle inertial measurement unit is determined by inputs NcIMUxn, NcIMUyn, and NcIMUzn.

Table 25. Output Parameters for Rotor-Furl Motions.

Name	Other Name(s)	Description	Convention	Units
RotFurlP	RotFurl	Rotor-furl angle (position)	About the rotor-furl axis (see Figure 17)	(deg)
RotFurlV		Rotor-furl angular velocity	About the rotor-furl axis (see Figure 17)	(deg/sec)
RotFurlA		Rotor-furl angular acceleration	About the rotor-furl axis (see Figure 17)	(deg/sec ²)

Table 26. Output Parameters for Tail-Furl Motions.

Name	Other Name(s)	Description	Convention	Units
TailFurlP	TailFurl	Tail-furl angle (position)	About the tail-furl axis (see Figure 17)	(deg)
TailFurlV		Tail -furl angular velocity	About the tail-furl axis (see Figure 17)	(deg/sec)
TailFurlA		Tail -furl angular acceleration	About the tail-furl axis (see Figure 17)	(deg/sec ²)

Table 27. Output Parameters for Nacelle Yaw Motions.

Name	Other Name(s)	Description	Convention	Units
YawPzn	YawPzp NacYawP NacYaw YawPos	Nacelle yaw angle (position)	About the Z_n - and Z_p -axes	(deg)
YawVzn	YawVzp NacYawV YawRate	Nacelle yaw angular velocity	About the Z_n - and Z_p -axes	(deg/sec)
YawAzn	YawAzp NacYawA YawAccel	Nacelle yaw angular acceleration	About the Z_n - and Z_p -axes	(deg/sec ²)
NacYawErr		Nacelle yaw error <i>estimate</i> . This is computed as follows: $NacYawErr = HorWndDir - YawPzn - YawBrRDzt - PtfmRDzi$. This estimate is not accurate instantaneously in the presence of significant tower deflection or platform angular (rotational) displacement since the angles used in the computation are not all defined about the same axis of rotation. However, the estimate should be useful in a yaw controller if averaged over a time scale long enough to diminish the effects of tower and platform motions (i.e., much longer than the period of oscillation). (unavailable if <code>CompAero = False</code>)	About the Z_i -axis	(deg)

Table 28. Output Parameters for Tower-Top, Yaw-Bearing Motions.

Name	Other Name(s)	Description	Convention	Units
YawBrTDxp		Tower-top / yaw bearing fore-aft (translational) deflection (relative to the undeflected position)	Directed along the x_p -axis	(m)
YawBrTDyp		Tower-top / yaw bearing side-to-side (translational) deflection (relative to the undeflected position)	Directed along the y_p -axis	(m)
YawBrTDzp		Tower-top / yaw bearing axial (translational) deflection (relative to the undeflected position)	Directed along the z_p -axis	(m)
YawBrTDxt	TTDspFA	Tower-top / yaw bearing fore-aft (translational) deflection (relative to the undeflected position)	Directed along the x_t -axis	(m)
YawBrTDyt	TTDspSS	Tower-top / yaw bearing side-to-side (translational) deflection (relative to the undeflected position)	Directed along the y_t -axis	(m)
YawBrTDzt	TTDspAx	Tower-top / yaw bearing axial (translational) deflection (relative to the undeflected position)	Directed along the z_t -axis	(m)
YawBrTAXp		Tower-top / yaw bearing fore-aft (translational) acceleration (absolute)	Directed along the x_p -axis	(m/sec ²)
YawBrTAYp		Tower-top / yaw bearing side-to-side (translational) acceleration (absolute)	Directed along the y_p -axis	(m/sec ²)
YawBrTAzp		Tower-top / yaw bearing axial (translational) acceleration (absolute)	Directed along the z_p -axis	(m/sec ²)
YawBrRDxt	TTDspRoll	Tower-top / yaw bearing angular (rotational) roll deflection (relative to the undeflected position). In ADAMS, it is output as an Euler angle computed as the 3 rd rotation in the yaw-pitch-roll rotation sequence. It is not output as an Euler angle in FAST, which assumes small tower deflections, so that the rotation sequence does not matter.	About the x_t -axis	(deg)
YawBrRDyt	TTDspPtch	Tower-top / yaw bearing angular (rotational) pitch deflection (relative to the undeflected position). In ADAMS, it is output as an Euler angle computed as the 2 nd rotation in the yaw-pitch-roll rotation sequence. It is not output as an Euler angle in FAST, which assumes small tower deflections, so that the rotation sequence does not matter.	About the y_t -axis	(deg)
YawBrRDzt	TTDspTwst	Tower-top / yaw bearing torsional deflection (relative to the undeflected position). This output will always be zero for FAST simulation results. Use it for examining tower torsional deflections of ADAMS simulations run using ADAMS datasets created using the FAST-to-ADAMS preprocessor. In ADAMS, it is output as an Euler angle computed as the 1 st rotation in the yaw-pitch-roll rotation sequence.	About the z_t -axis	(deg)
YawBrRVxp		Tower-top / yaw bearing angular (rotational) roll velocity (absolute)	About the x_p -axis	(deg/sec)
YawBrRVyp		Tower-top / yaw bearing angular (rotational) pitch velocity (absolute)	About the y_p -axis	(deg/sec)

Name	Other Name(s)	Description	Convention	Units
YawBrRVzp		Tower-top / yaw bearing angular (rotational) torsion velocity. This output will always be very close to zero for FAST simulation results. Use it for examining tower torsional deflections of ADAMS simulations run using ADAMS datasets created using the FAST-to-ADAMS preprocessor. (absolute)	About the z_p -axis	(deg/sec)
YawBrRAxp		Tower-top / yaw bearing angular (rotational) roll acceleration (absolute)	About the x_p -axis	(deg/sec ²)
YawBrRAYp		Tower-top / yaw bearing angular (rotational) pitch acceleration (absolute)	About the y_p -axis	(deg/sec ²)
YawBrRAzp		Tower-top / yaw bearing angular (rotational) torsion acceleration. This output will always be very close to zero for FAST simulation results. Use it for examining tower torsional deflections of ADAMS simulations run using ADAMS datasets created using the FAST-to-ADAMS preprocessor. (absolute)	About the z_p -axis	(deg/sec ²)

Table 29. Output Parameters for Local Tower Motions*.

Name	Other Name(s)	Description	Convention	Units
TwHt1ALxt		Local tower fore-aft (translational) acceleration (absolute) of tower gage 1 (unavailable if NTwGages = 0)	Directed along the local x_t -axis	(m/sec ²)
TwHt1ALyt		Local tower side-to-side (translational) acceleration (absolute) of tower gage 1 (unavailable if NTwGages = 0)	Directed along the local y_t -axis	(m/sec ²)
TwHt1ALzt		Local tower axial (translational) acceleration (absolute) of tower gage 1 (unavailable if NTwGages = 0)	Directed along the local z_t -axis	(m/sec ²)
TwHt2ALxt		Local tower fore-aft (translational) acceleration (absolute) of tower gage 2 (unavailable if NTwGages < 2)	Directed along the local x_t -axis	(m/sec ²)
TwHt2ALyt		Local tower side-to-side (translational) acceleration (absolute) of tower gage 2 (unavailable if NTwGages < 2)	Directed along the local y_t -axis	(m/sec ²)
TwHt2ALzt		Local tower axial (translational) acceleration (absolute) of tower gage 2 (unavailable if NTwGages < 2)	Directed along the local z_t -axis	(m/sec ²)
TwHt3ALxt		Local tower fore-aft (translational) acceleration (absolute) of tower gage 3 (unavailable if NTwGages < 3)	Directed along the local x_t -axis	(m/sec ²)
TwHt3ALyt		Local tower side-to-side (translational) acceleration (absolute) of tower gage 3 (unavailable if NTwGages < 3)	Directed along the local y_t -axis	(m/sec ²)
TwHt3ALzt		Local tower axial (translational) acceleration (absolute) of tower gage 3 (unavailable if NTwGages < 3)	Directed along the local z_t -axis	(m/sec ²)
TwHt4ALxt		Local tower fore-aft (translational) acceleration (absolute) of tower gage 4 (unavailable if NTwGages < 4)	Directed along the local x_t -axis	(m/sec ²)
TwHt4ALyt		Local tower side-to-side (translational) acceleration (absolute) of tower gage 4 (unavailable if NTwGages < 4)	Directed along the local y_t -axis	(m/sec ²)
TwHt4ALzt		Local tower axial (translational) acceleration (absolute) of tower gage 4 (unavailable if NTwGages < 4)	Directed along the local z_t -axis	(m/sec ²)
TwHt5ALxt		Local tower fore-aft (translational) acceleration (absolute) of tower gage 5 (unavailable if NTwGages < 5)	Directed along the local x_t -axis	(m/sec ²)
TwHt5ALyt		Local tower side-to-side (translational) acceleration (absolute) of tower gage 5 (unavailable if NTwGages < 5)	Directed along the local y_t -axis	(m/sec ²)
TwHt5ALzt		Local tower axial (translational) acceleration (absolute) of tower gage 5 (unavailable if NTwGages < 5)	Directed along the local z_t -axis	(m/sec ²)

* These motions are for the nodes you specify with the TwrGagNd input array.

Table 30. Output Parameters for Platform Motions.

Name	Other Name(s)	Description	Convention	Units
PtfmTDxt		Platform horizontal surge (translational) displacement	Directed along the x_t -axis	(m)
PtfmTDyt		Platform horizontal sway (translational) displacement	Directed along the y_t -axis	(m)
PtfmTDzt		Platform vertical heave (translational) displacement	Directed along the z_t -axis	(m)
PtfmTDxi	PtfmSurge	Platform horizontal surge (translational) displacement	Directed along the x_i -axis	(m)
PtfmTDyi	PtfmSway	Platform horizontal sway (translational) displacement	Directed along the y_i -axis	(m)
PtfmTDzi	PtfmHeave	Platform vertical heave (translational) displacement	Directed along the z_i -axis	(m)
PtfmTVxt		Platform horizontal surge (translational) velocity	Directed along the x_t -axis	(m/sec)
PtfmTVyt		Platform horizontal sway (translational) velocity	Directed along the y_t -axis	(m/sec)
PtfmTVzt		Platform vertical heave (translational) velocity	Directed along the z_t -axis	(m/sec)
PtfmTVxi		Platform horizontal surge (translational) velocity	Directed along the x_i -axis	(m/sec)
PtfmTVyi		Platform horizontal sway (translational) velocity	Directed along the y_i -axis	(m/sec)
PtfmTVzi		Platform vertical heave (translational) velocity	Directed along the z_i -axis	(m/sec)
PtfmTAXt		Platform horizontal surge (translational) acceleration	Directed along the x_t -axis	(m/sec ²)
PtfmTAYt		Platform horizontal sway (translational) acceleration	Directed along the y_t -axis	(m/sec ²)
PtfmTAzt		Platform vertical heave (translational) acceleration	Directed along the z_t -axis	(m/sec ²)
PtfmTAXi		Platform horizontal surge (translational) acceleration	Directed along the x_i -axis	(m/sec ²)
PtfmTAYi		Platform horizontal sway (translational) acceleration	Directed along the y_i -axis	(m/sec ²)
PtfmTAzi		Platform vertical heave (translational) acceleration	Directed along the z_i -axis	(m/sec ²)
PtfmRDxi	PtfmRoll	Platform roll tilt angular (rotational) displacement. In ADAMS, it is output as an Euler angle computed as the 3 rd rotation in the yaw-pitch-roll rotation sequence. It is not output as an Euler angle in FAST, which assumes small rotational platform displacements, so that the rotation sequence does not matter.	About the x_i -axis	(deg)
PtfmRDyi	PtfmPitch	Platform pitch tilt angular (rotational) displacement. In ADAMS, it is output as an Euler angle computed as the 2 nd rotation in the yaw-pitch-roll rotation sequence. It is not output as an Euler angle in FAST, which assumes small rotational platform displacements, so that the rotation sequence does not matter.	About the y_i -axis	(deg)

Name	Other Name(s)	Description	Convention	Units
PtfmRDzi	PtfmYaw	Platform yaw angular (rotational) displacement. In ADAMS, it is output as an Euler angle computed as the 1 st rotation in the yaw-pitch-roll rotation sequence. It is not output as an Euler angle in FAST, which assumes small rotational platform displacements, so that the rotation sequence does not matter.	About the z _t -axis	(deg)
PtfmRVxt		Platform roll tilt angular (rotational) velocity	About the x _t -axis	(deg/sec)
PtfmRVyt		Platform pitch tilt angular (rotational) velocity	About the y _t -axis	(deg/sec)
PtfmRVzt		Platform yaw angular (rotational) velocity	About the z _t -axis	(deg/sec)
PtfmRVxi		Platform roll tilt angular (rotational) velocity	About the x _t -axis	(deg/sec)
PtfmRVyi		Platform pitch tilt angular (rotational) velocity	About the y _t -axis	(deg/sec)
PtfmRVzi		Platform yaw angular (rotational) velocity	About the z _t -axis	(deg/sec)
PtfmRAxt		Platform roll tilt angular (rotational) acceleration	About the x _t -axis	(deg/sec ²)
PtfmRAyt		Platform pitch tilt angular (rotational) acceleration	About the y _t -axis	(deg/sec ²)
PtfmRAzt		Platform yaw angular (rotational) acceleration	About the z _t -axis	(deg/sec ²)
PtfmRAxi		Platform roll tilt angular (rotational) acceleration	About the x _t -axis	(deg/sec ²)
PtfmRAyi		Platform pitch tilt angular (rotational) acceleration	About the y _t -axis	(deg/sec ²)
PtfmRAzi		Platform yaw angular (rotational) acceleration	About the z _t -axis	(deg/sec ²)

Table 31. Output Parameters for Blade 1 Root Loads.

Name	Other Name(s)	Description	Convention	Units
RootFxc1		Blade 1 out-of-plane shear force at the blade root	Directed along the $x_{c,1}$ -axis	(kN)
RootFyc1		Blade 1 in-plane shear force at the blade root	Directed along the $y_{c,1}$ -axis	(kN)
RootFzc1	RootFzb1	Blade 1 axial force at the blade root	Directed along the $z_{c,1}$ - and $z_{b,1}$ -axes	(kN)
RootFxb1		Blade 1 flapwise shear force at the blade root	Directed along the $x_{b,1}$ -axis	(kN)
RootFyb1		Blade 1 edgewise shear force at the blade root	Directed along the $y_{b,1}$ -axis	(kN)
RootMxc1	RootMIP1	Blade 1 in-plane moment (i.e., the moment caused by in-plane forces) at the blade root	About the $x_{c,1}$ -axis	(kN·m)
RootMyc1	RootMOoP1	Blade 1 out-of-plane moment (i.e., the moment caused by out-of-plane forces) at the blade root	About the $y_{c,1}$ -axis	(kN·m)
RootMzc1	RootMzb1	Blade 1 pitching moment at the blade root	About the $z_{c,1}$ - and $z_{b,1}$ -axes	(kN·m)
RootMxb1	RootMEdg1	Blade 1 edgewise moment (i.e., the moment caused by edgewise forces) at the blade root	About the $x_{b,1}$ -axis	(kN·m)
RootMyb1	RootMFlp1	Blade 1 flapwise moment (i.e., the moment caused by flapwise forces) at the blade root	About the $y_{b,1}$ -axis	(kN·m)

Table 32. Output Parameters for Blade 2* Root Loads.

Name	Other Name(s)	Description	Convention	Units
RootFxc2		Blade 2 out-of-plane shear force at the blade root	Directed along the $x_{c,2}$ -axis	(kN)
RootFyc2		Blade 2 in-plane shear force at the blade root	Directed along the $y_{c,2}$ -axis	(kN)
RootFzc2	RootFzb2	Blade 2 axial force at the blade root	Directed along the $z_{c,2}$ - and $z_{b,2}$ -axes	(kN)
RootFxb2		Blade 2 flapwise shear force at the blade root	Directed along the $x_{b,2}$ -axis	(kN)
RootFyb2		Blade 2 edgewise shear force at the blade root	Directed along the $y_{b,2}$ -axis	(kN)
RootMxc2	RootMIP2	Blade 2 in-plane moment (i.e., the moment caused by in-plane forces) at the blade root	About the $x_{c,2}$ -axis	(kN·m)
RootMyc2	RootMOoP2	Blade 2 out-of-plane moment (i.e., the moment caused by out-of-plane forces) at the blade root	About the $y_{c,2}$ -axis	(kN·m)
RootMzc2	RootMzb2	Blade 2 pitching moment at the blade root	About the $z_{c,2}$ - and $z_{b,2}$ -axes	(kN·m)
RootMxb2	RootMEdg2	Blade 2 edgewise moment (i.e., the moment caused by edgewise forces) at the blade root	About the $x_{b,2}$ -axis	(kN·m)
RootMyb2	RootMFlp2	Blade 2 flapwise moment (i.e., the moment caused by flapwise forces) at the blade root	About the $y_{b,2}$ -axis	(kN·m)

* For three-bladed rotors, blade 3 is ahead of blade 2, which is ahead of blade 1, so that the order of blades passing through a given azimuth is 3-2-1-repeat.

Table 33. Output Parameters for Blade 3* Root Loads.

Name	Other Name(s)	Description	Convention	Units
RootFxc3		Blade 3 out-of-plane shear force at the blade root (unavailable for two-bladed turbines)	Directed along the $x_{c,3}$ -axis	(kN)
RootFyc3		Blade 3 in-plane shear force at the blade root (unavailable for two-bladed turbines)	Directed along the $y_{c,3}$ -axis	(kN)
RootFzc3	RootFzb3	Blade 3 axial force at the blade root (unavailable for two-bladed turbines)	Directed along the $z_{c,3}$ - and $z_{b,3}$ -axes	(kN)
RootFxb3		Blade 3 flapwise shear force at the blade root (unavailable for two-bladed turbines)	Directed along the $x_{b,3}$ -axis	(kN)
RootFyb3		Blade 3 edgewise shear force at the blade root (unavailable for two-bladed turbines)	Directed along the $y_{b,3}$ -axis	(kN)
RootMxc3	RootMIP3	Blade 3 in-plane moment (i.e., the moment caused by in-plane forces) at the blade root (unavailable for two-bladed turbines)	About the $x_{c,3}$ -axis	(kN·m)
RootMyc3	RootMOoP3	Blade 3 out-of-plane moment (i.e., the moment caused by out-of-plane forces) at the blade root (unavailable for two-bladed turbines)	About the $y_{c,3}$ -axis	(kN·m)
RootMzc3	RootMzb3	Blade 3 pitching moment at the blade root (unavailable for two-bladed turbines)	About the $z_{c,3}$ - and $z_{b,3}$ -axes	(kN·m)
RootMxb3	RootMEdg3	Blade 3 edgewise moment (i.e., the moment caused by edgewise forces) at the blade root (unavailable for two-bladed turbines)	About the $x_{b,3}$ -axis	(kN·m)
RootMyb3	RootMFlp3	Blade 3 flapwise moment (i.e., the moment caused by flapwise forces) at the blade root (unavailable for two-bladed turbines)	About the $y_{b,3}$ -axis	(kN·m)

* For three-bladed rotors, blade 3 is ahead of blade 2, which is ahead of blade 1, so that the order of blades passing through a given azimuth is 3-2-1-repeat.

Table 34. Output Parameters for Blade 1 Local Span Loads*.

Name	Other Name(s)	Description	Convention	Units
Spn1MLxb1		Blade 1 <i>local</i> edgewise moment at span station 1 (unavailable if NBIGages = 0)	About the <i>local</i> $x_{b,1}$ -axis	(kN·m)
Spn1MLyb1		Blade 1 <i>local</i> flapwise moment at span station 1 (unavailable if NBIGages = 0)	About the <i>local</i> $y_{b,1}$ -axis	(kN·m)
Spn1MLzb1		Blade 1 <i>local</i> pitching moment at span station 1 (unavailable if NBIGages = 0)	About the <i>local</i> $z_{b,1}$ -axis	(kN·m)
Spn2MLxb1		Blade 1 <i>local</i> edgewise moment at span station 2 (unavailable if NBIGages < 2)	About the <i>local</i> $x_{b,1}$ -axis	(kN·m)
Spn2MLyb1		Blade 1 <i>local</i> flapwise moment at span station 2 (unavailable if NBIGages < 2)	About the <i>local</i> $y_{b,1}$ -axis	(kN·m)
Spn2MLzb1		Blade 1 <i>local</i> pitching moment at span station 2 (unavailable if NBIGages < 2)	About the <i>local</i> $z_{b,1}$ -axis	(kN·m)
Spn3MLxb1		Blade 1 <i>local</i> edgewise moment at span station 3 (unavailable if NBIGages < 3)	About the <i>local</i> $x_{b,1}$ -axis	(kN·m)
Spn3MLyb1		Blade 1 <i>local</i> flapwise moment at span station 3 (unavailable if NBIGages < 3)	About the <i>local</i> $y_{b,1}$ -axis	(kN·m)
Spn3MLzb1		Blade 1 <i>local</i> pitching moment at span station 3 (unavailable if NBIGages < 3)	About the <i>local</i> $z_{b,1}$ -axis	(kN·m)
Spn4MLxb1		Blade 1 <i>local</i> edgewise moment at span station 4 (unavailable if NBIGages < 4)	About the <i>local</i> $x_{b,1}$ -axis	(kN·m)
Spn4MLyb1		Blade 1 <i>local</i> flapwise moment at span station 4 (unavailable if NBIGages < 4)	About the <i>local</i> $y_{b,1}$ -axis	(kN·m)
Spn4MLzb1		Blade 1 <i>local</i> pitching moment at span station 4 (unavailable if NBIGages < 4)	About the <i>local</i> $z_{b,1}$ -axis	(kN·m)
Spn5MLxb1		Blade 1 <i>local</i> edgewise moment at span station 5 (unavailable if NBIGages < 5)	About the <i>local</i> $x_{b,1}$ -axis	(kN·m)
Spn5MLyb1		Blade 1 <i>local</i> flapwise moment at span station 5 (unavailable if NBIGages < 5)	About the <i>local</i> $y_{b,1}$ -axis	(kN·m)
Spn5MLzb1		Blade 1 <i>local</i> pitching moment at span station 5 (unavailable if NBIGages < 5)	About the <i>local</i> $z_{b,1}$ -axis	(kN·m)

* These loads are for the nodes you specify with the BldGagNd input array.

Table 35. Output Parameters for Hub and Rotor Loads.

Name	Other Name(s)	Description	Convention	Units
LSShftFxa	LSShftFxs LSSGagFxa LSSGagFxs RotThrust	LSS thrust force (this is constant along the shaft and is equivalent to the rotor thrust force)	Directed along the x_a - and x_s -axes	(kN)
LSShftFya	LSSGagFya	Rotating LSS shear force (this is constant along the shaft)	Directed along the y_a -axis	(kN)
LSShftFza	LSSGagFza	Rotating LSS shear force (this is constant along the shaft)	Directed along the z_a -axis	(kN)
LSShftFys	LSSGagFys	Nonrotating LSS shear force (this is constant along the shaft)	Directed along the y_s -axis	(kN)
LSShftFzs	LSSGagFzs	Nonrotating LSS shear force (this is constant along the shaft)	Directed along the z_s -axis	(kN)
LSShftMxa	LSShftMxs LSSGagMxa LSSGagMxs RotTorq LSShftTq	LSS torque (this is constant along the shaft and is equivalent to the rotor torque)	About the x_a - and x_s -axes	(kN·m)
LSSTipMya		Rotating LSS bending moment at the shaft tip (teeter pin for two-bladed turbines, apex of rotation for three-bladed turbines)	About the y_a -axis	(kN·m)
LSSTipMza		Rotating LSS bending moment at the shaft tip (teeter pin for two-bladed turbines, apex of rotation for three-bladed turbines)	About the z_a -axis	(kN·m)
LSSTipMys		Nonrotating LSS bending moment at the shaft tip (teeter pin for two-bladed turbines, apex of rotation for three-bladed turbines)	About the y_s -axis	(kN·m)
LSSTipMzs		Nonrotating LSS bending moment at the shaft tip (teeter pin for two-bladed turbines, apex of rotation for three-bladed turbines)	About the z_s -axis	(kN·m)
CThrstAzm		Azimuth location of the center of thrust. This is estimated using values of LSSTipMys, LSSTipMzs, and RotThrust.	About the x_a - and x_s -axes	(deg)
CThrstRad	CThrstArm	Dimensionless radial (arm) location of the center of thrust. This is estimated using values of LSSTipMys, LSSTipMzs, and RotThrust. (nondimensionalized using the undeflected tip radius normal to the shaft and limited to values between 0 and 1 (inclusive))	Always positive (directed radially outboard at azimuth angle CThrstAzm)	(-)
RotPwr	LSShftPwr	Rotor power (this is equivalent to the LSS power)	N/A	(kW)
RotCq	LSShftCq	Rotor torque coefficient (this is equivalent to the LSS torque coefficient) (unavailable if CompAero is False)	N/A	(-)
RotCp	LSShftCp	Rotor power coefficient (this is equivalent to the LSS power coefficient) (unavailable if CompAero is False)	N/A	(-)
RotCt	LSShftCt	Rotor thrust coefficient (this is equivalent to the LSS thrust coefficient) (unavailable if CompAero is False)	N/A	(-)

Table 36. Output Parameters for Shaft Strain-Gage Loads.

Name	Other Name(s)	Description	Convention	Units
LSSGagMya		Rotating LSS bending moment at the shaft's strain gage (shaft strain gage located by input ShftGagL)	About the y_a -axis	(kN·m)
LSSGagMza		Rotating LSS bending moment at the shaft's strain gage (shaft strain gage located by input ShftGagL)	About the z_a -axis	(kN·m)
LSSGagMys		Nonrotating LSS bending moment at the shaft's strain gage (shaft strain gage located by input ShftGagL)	About the y_s -axis	(kN·m)
LSSGagMzs		Nonrotating LSS bending moment at the shaft's strain gage (shaft strain gage located by input ShftGagL)	About the z_s -axis	(kN·m)

Table 37. Output Parameters for Generator and HSS Loads.

Name	Other Name(s)	Description	Convention	Units
HSShftTq		HSS torque (this is constant along the shaft)	Same sign as LSShftTq / RotTorq / LSShftMxa / LSShftMxs / LSSGagMxa / LSSGagMxs	(kN·m)
HSShftPwr		HSS power	Same sign as HSShftTq	(kW)
HSShftCq		HSS torque coefficient (unavailable if CompAero is False)	N/A	(-)
HSShftCp		HSS power coefficient (unavailable if CompAero is False)	N/A	(-)
GenTq		Electrical generator torque	Positive reflects power extracted and negative represents a motoring-up situation or power input	(kN·m)
GenPwr		Electrical generator power	Same sign as GenTq	(kW)
GenCq		Electrical generator torque coefficient (unavailable if CompAero is False)	N/A	(-)
GenCp		Electrical generator power coefficient (unavailable if CompAero is False)	N/A	(-)
HSSBrTq		HSS brake torque (i.e., the moment applied to the HSS by the brake)	Always positive (indicating dissipation of power)	(kN·m)

Table 38. Output Parameters for Rotor-Furl Bearing Loads.

Name	Other Name(s)	Description	Convention	Units
RFrIBrM		Rotor-furl bearing moment	About the rotor-furl axis (see Figure 17)	(kN·m)

Table 39. Output Parameters for Tail-Furl Bearing Loads.

Name	Other Name(s)	Description	Convention	Units
TFrIBrM		Tail-furl bearing moment	About the tail-furl axis (see Figure 17)	(kN·m)

Table 40. Output Parameters for Tail Fin Aerodynamic Loads.

Name	Other Name(s)	Description	Convention	Units
TFinAlpha		Tail fin angle of attack. This is the angle between the relative velocity of the wind-inflow at the tail fin center-of-pressure and the tail fin chordline. (unavailable if CompAero is False)	About the tail fin z-axis, which is the axis in the tail fin plane normal to the chordline (see Figure 19)	(deg)
TFinCLift		Tail fin dimensionless lift coefficient (unavailable if CompAero is False)	N/A	(-)
TFinCDrag		Tail fin dimensionless drag coefficient (unavailable if CompAero is False)	N/A	(-)
TFinDnPrs		Tail fin dynamic pressure, equal to $\frac{1}{2} \cdot \rho \cdot V_{rel}^2$ where V_{rel} is the relative velocity of the wind-inflow at the tail fin center-of-pressure (unavailable if CompAero is False)	N/A	(Pa)
TFinCPFx		Tangential aerodynamic force at the tail fin center-of-pressure (unavailable if CompAero is False)	Directed along the tail fin x-axis, which is the axis along the chordline, positive towards the trailing edge (see Figure 19)	(kN)
TFinCPFy		Normal aerodynamic force at the tail fin center-of-pressure (unavailable if CompAero is False)	Directed along the tail fin y-axis, which is orthogonal to the tail fin plane (see Figure 19)	(kN)

Table 41. Output Parameters for Tower-Top, Yaw-Bearing Loads.

Name	Other Name(s)	Description	Convention	Units
YawBrFxn		Rotating (with nacelle) tower-top / yaw bearing shear force	Directed along the x_n -axis	(kN)
YawBrFyn		Rotating (with nacelle) tower-top / yaw bearing shear force	Directed along the y_n -axis	(kN)
YawBrFzn	YawBrFzp	Tower-top / yaw bearing axial force	Directed along the Z_n - and Z_p -axes	(kN)
YawBrFxp		Tower-top / yaw bearing fore-aft (nonrotating) shear force	Directed along the x_p -axis	(kN)
YawBrFyp		Tower-top / yaw bearing side-to-side (nonrotating) shear force	Directed along the y_p -axis	(kN)
YawBrMxn		Rotating (with nacelle) tower-top / yaw bearing roll moment	About the x_n -axis	(kN·m)
YawBrMyn		Rotating (with nacelle) tower-top / yaw bearing pitch moment	About the y_n -axis	(kN·m)
YawBrMzn	YawBrMzp YawMom	Tower-top / yaw bearing yaw moment	About the Z_n - and Z_p -axes	(kN·m)
YawBrMxp		Nonrotating tower-top / yaw bearing roll moment	About the x_p -axis	(kN·m)
YawBrMyp		Nonrotating tower-top / yaw bearing pitch moment	About the y_p -axis	(kN·m)

Table 42. Output Parameters for Tower Base Loads.

Name	Other Name(s)	Description	Convention	Units
TwrBsFxt		Tower base fore-aft shear force	Directed along the x_t -axis	(kN)
TwrBsFyt		Tower base side-to-side shear force	Directed along the y_t -axis	(kN)
TwrBsFzt		Tower base axial force	Directed along the Z_t -axis	(kN)
TwrBsMxt		Tower base roll (or side-to-side) moment (i.e., the moment caused by side-to-side forces)	About the x_t -axis	(kN·m)
TwrBsMyt		Tower base pitching (or fore-aft) moment (i.e., the moment caused by fore-aft forces)	About the y_t -axis	(kN·m)
TwrBsMzt		Tower base yaw (or torsional) moment	About the Z_t -axis	(kN·m)

Table 43. Output Parameters for Local Tower Loads*

Name	Other Name(s)	Description	Convention	Units
TwHt1MLxt		Local tower roll (or side-to-side) moment of tower gage 1 (unavailable if NTwGages = 0)	About the local x_t -axis	(kN·m)
TwHt1MLyt		Local tower pitching (or fore-aft) moment of tower gage 1 (unavailable if NTwGages = 0)	About the local y_t -axis	(kN·m)
TwHt1MLzt		Local tower yaw (or torsional) moment of tower gage 1 (unavailable if NTwGages = 0)	About the local z_t -axis	(kN·m)
TwHt2MLxt		Local tower roll (or side-to-side) moment of tower gage 2 (unavailable if NTwGages < 2)	About the local x_t -axis	(kN·m)
TwHt2MLyt		Local tower pitching (or fore-aft) moment of tower gage 2 (unavailable if NTwGages < 2)	About the local y_t -axis	(kN·m)
TwHt2MLzt		Local tower yaw (or torsional) moment of tower gage 2 (unavailable if NTwGages < 2)	About the local z_t -axis	(kN·m)
TwHt3MLxt		Local tower roll (or side-to-side) moment of tower gage 3 (unavailable if NTwGages < 3)	About the local x_t -axis	(kN·m)
TwHt3MLyt		Local tower pitching (or fore-aft) moment of tower gage 3 (unavailable if NTwGages < 3)	About the local y_t -axis	(kN·m)
TwHt3MLzt		Local tower yaw (or torsional) moment of tower gage 3 (unavailable if NTwGages < 3)	About the local z_t -axis	(kN·m)
TwHt4MLxt		Local tower roll (or side-to-side) moment of tower gage 4 (unavailable if NTwGages < 4)	About the local x_t -axis	(kN·m)
TwHt4MLyt		Local tower pitching (or fore-aft) moment of tower gage 4 (unavailable if NTwGages < 4)	About the local y_t -axis	(kN·m)
TwHt4MLzt		Local tower yaw (or torsional) moment of tower gage 4 (unavailable if NTwGages < 4)	About the local z_t -axis	(kN·m)
TwHt5MLxt		Local tower roll (or side-to-side) moment of tower gage 5 (unavailable if NTwGages < 5)	About the local x_t -axis	(kN·m)
TwHt5MLyt		Local tower pitching (or fore-aft) moment of tower gage 5 (unavailable if NTwGages < 5)	About the local y_t -axis	(kN·m)
TwHt5MLzt		Local tower yaw (or torsional) moment of tower gage 5 (unavailable if NTwGages < 5)	About the local z_t -axis	(kN·m)

* These loads are for the nodes you specify with the TwrGagNd input array.

Table 44. Output Parameters for Platform Loads.

Name	Other Name(s)	Description	Convention	Units
PtfmFxt		Platform horizontal surge shear force	Directed along the x_t -axis	(kN)
PtfmFyt		Platform horizontal sway shear force	Directed along the y_t -axis	(kN)
PtfmFzt		Platform vertical heave force	Directed along the z_t -axis	(kN)
PtfmFxi		Platform horizontal surge shear force	Directed along the x_i -axis	(kN)
PtfmFyi		Platform horizontal sway shear force	Directed along the y_i -axis	(kN)
PtfmFzi		Platform vertical heave force	Directed along the z_i -axis	(kN)
PtfmMxt		Platform roll tilt moment	About the x_t -axis	(kN·m)
PtfmMyt		Platform pitch tilt moment	About the y_t -axis	(kN·m)
PtfmMzt		Platform yaw moment	About the z_t -axis	(kN·m)
PtfmMxi		Platform roll tilt moment	About the x_i -axis	(kN·m)
PtfmMyi		Platform pitch tilt moment	About the y_i -axis	(kN·m)
PtfmMzi		Platform yaw moment	About the z_i -axis	(kN·m)

These predictions were generated by FAST (v4.00, 09-Jul-2002) on 09-Jul-2002 at 09:38:47.
 The aerodynamic calculations were made by AeroDyn (12.46, 23-May-2002).

FAST certification test #1 for AWT-27CR2 with many DOFs.

Time (sec)	uWind (m/sec)	Azimuth (deg)	TeetDefl (deg)	RootMycl (kN·m)	RootMxc1 (kN·m)	RotTorq (kN·m)	YawBrMzn (kN·m)	TTDspFA (m)
10.000	1.039E+01	1.180E+01	1.031E+00	3.533E+01	2.039E+01	3.613E+01	-2.280E+00	4.922E-02
10.020	1.039E+01	1.831E+01	9.697E-01	3.642E+01	2.085E+01	3.558E+01	-1.996E+00	4.920E-02
10.040	1.039E+01	2.482E+01	8.946E-01	3.632E+01	2.235E+01	3.525E+01	-2.426E+00	4.920E-02
10.060	1.039E+01	3.134E+01	8.081E-01	3.538E+01	2.447E+01	3.514E+01	-3.286E+00	4.920E-02
10.080	1.039E+01	3.785E+01	7.116E-01	3.473E+01	2.672E+01	3.517E+01	-4.282E+00	4.918E-02
10.100	1.039E+01	4.436E+01	6.067E-01	3.503E+01	2.868E+01	3.526E+01	-5.124E+00	4.913E-02
10.120	1.039E+01	5.088E+01	4.943E-01	3.604E+01	3.011E+01	3.541E+01	-5.681E+00	4.906E-02
10.140	1.039E+01	5.739E+01	3.751E-01	3.707E+01	3.110E+01	3.565E+01	-5.993E+00	4.900E-02
10.160	1.039E+01	6.391E+01	2.498E-01	3.759E+01	3.191E+01	3.600E+01	-6.148E+00	4.897E-02
10.180	1.039E+01	7.042E+01	1.198E-01	3.769E+01	3.271E+01	3.642E+01	-6.184E+00	4.896E-02
10.200	1.039E+01	7.694E+01	-1.301E-02	3.777E+01	3.353E+01	3.684E+01	-6.121E+00	4.896E-02
10.220	1.039E+01	8.345E+01	-1.463E-01	3.813E+01	3.424E+01	3.720E+01	-5.908E+00	4.895E-02
10.240	1.039E+01	8.997E+01	-2.775E-01	3.868E+01	3.465E+01	3.745E+01	-5.546E+00	4.893E-02
10.260	1.039E+01	9.649E+01	-4.041E-01	3.916E+01	3.468E+01	3.764E+01	-5.027E+00	4.892E-02
10.280	1.039E+01	1.030E+02	-5.241E-01	3.939E+01	3.431E+01	3.777E+01	-4.365E+00	4.892E-02
10.300	1.039E+01	1.095E+02	-6.357E-01	3.942E+01	3.365E+01	3.787E+01	-3.590E+00	4.895E-02
10.320	1.039E+01	1.160E+02	-7.378E-01	3.945E+01	3.276E+01	3.791E+01	-2.757E+00	4.899E-02
10.340	1.039E+01	1.226E+02	-8.296E-01	3.959E+01	3.170E+01	3.791E+01	-1.938E+00	4.902E-02
10.360	1.039E+01	1.291E+02	-9.103E-01	3.985E+01	3.045E+01	3.788E+01	-1.210E+00	4.905E-02
10.380	1.039E+01	1.356E+02	-9.793E-01	4.009E+01	2.902E+01	3.783E+01	-6.359E-01	4.907E-02
10.400	1.039E+01	1.421E+02	-1.036E+00	4.028E+01	2.743E+01	3.777E+01	-1.897E-01	4.909E-02
10.420	1.039E+01	1.486E+02	-1.079E+00	4.039E+01	2.570E+01	3.772E+01	1.200E-01	4.912E-02
10.440	1.039E+01	1.551E+02	-1.107E+00	4.055E+01	2.384E+01	3.768E+01	2.992E-01	4.914E-02
10.460	1.039E+01	1.617E+02	-1.121E+00	4.054E+01	2.179E+01	3.762E+01	2.539E-01	4.917E-02

Figure 30. Sample output file.

This linearized model file was generated by FAST (v6.00c-jmj, 15-Apr-2005) on 15-Apr-2005 at 11:24:16.
The aerodynamic calculations were made by AeroDyn (12.57, 29-Sept-2004).

FAST model of a 1.5 MW 3-bladed upwind baseline turbine.

Some Useful Information:

Type of steady state solution found	Trimmed collective blade pitch (TrimCase = 3)
Period of steady state solution (sec)	2.93212E+00
Iterations needed to find steady state solution	34
Displacement 2-norm of steady state solution (rad)	9.01316E-05
Velocity 2-norm of steady state solution (rad/s)	4.84390E-05
Number of equally-spaced azimuth steps, NAzimStep	4
Order of linearized model, MdlOrder	1
Number of active (enabled) DOFs	4 (8 states)
Number of control inputs, NInputs	2
Number of input wind disturbances, NDisturbs	1
Number of output measurements	5

Order of States in Linearized State Matrices:

Row/column 1 = Variable speed generator DOF (internal DOF index = DOF_GeAz)
Row/column 2 = 1st flapwise bending-mode DOF of blade 1 (internal DOF index = DOF_BF(1,1))
Row/column 3 = 1st flapwise bending-mode DOF of blade 2 (internal DOF index = DOF_BF(2,1))
Row/column 4 = 1st flapwise bending-mode DOF of blade 3 (internal DOF index = DOF_BF(3,1))
Row/column 5 to 8 = First derivatives of row/column 1 to 4.

Order of Control Inputs in Linearized State Matrices:

Column 1 = electrical generator torque (N·m) 7.95744E+03 op
Column 2 = rotor collective blade pitch (rad) 3.41938E-01 op

Order of Input Wind Disturbances in Linearized State Matrices:

Column 1 = horizontal hub-height wind speed (m/s) 1.80000E+01 op

Order of Output Measurements in Linearized State Matrices:

Row 1 = GenTq (kN·m)
Row 2 = GenPwr (kW)
Row 3 = BldPitch1 (deg)
Row 4 = OoPDefl1 (m)
Row 5 = IPDefl1 (m)

Linearized State Matrices:

```
----- Azimuth = 0.00 deg -----
op State | op | A - State | B - Input | Bd - Dstrb
Derivative | States | Matrix | Matrix | Matrix
2.143E+00 | 4.712E+00 | 0.000E+00 0.000E+00 0.000E+00 1.000E+00 0.000E+00 0.000E+00 0.000E+00 0.000E+00 | 0.000E+00 0.000E+00 | 0.000E+00
2.222E-01 | 4.928E-01 | 0.000E+00 0.000E+00 0.000E+00 0.000E+00 0.000E+00 1.000E+00 0.000E+00 0.000E+00 | 0.000E+00 0.000E+00 | 0.000E+00
-3.294E-02 | 6.283E-01 | 0.000E+00 0.000E+00 0.000E+00 0.000E+00 0.000E+00 1.000E+00 0.000E+00 0.000E+00 | 0.000E+00 0.000E+00 | 0.000E+00
-1.825E-01 | 4.442E-01 | 0.000E+00 0.000E+00 0.000E+00 0.000E+00 0.000E+00 1.000E+00 0.000E+00 0.000E+00 | 0.000E+00 0.000E+00 | 0.000E+00
8.973E-05 | 2.143E+00 | 3.515E-05 1.380E-01 1.373E-01 1.374E-01 1.087E-01 8.897E-03 9.439E-03 6.190E-03 | -3.027E-05 1.867E+00 | -7.305E-03
8.147E-03 | 2.222E-01 | 6.668E+00 -7.072E+01 -3.559E+00 -3.562E+00 -7.968E+01 -8.571E+00 -2.437E-01 -1.607E-01 | 7.851E-04 -8.277E+02 | 1.282E+01
-4.493E-01 | -3.294E-02 | -2.788E+00 -3.578E+00 -7.014E+01 -3.563E+00 -8.379E+01 -2.273E-01 -8.909E+00 -1.590E-01 | 7.847E-04 -8.522E+02 | 1.308E+01
3.781E-01 | -1.825E-01 | -4.118E+00 -3.579E+00 -3.560E+00 -7.020E+01 -6.411E+01 -2.279E-01 -2.445E-01 -6.834E+00 | 7.847E-04 -7.148E+02 | 1.124E+01
```

```
op Output | This column | C - Output | D - Trnsmt | Dd - DTsmt
Measurmnts | is blank | Matrix | Matrix | Matrix
7.957E+00 | | 0.000E+00 0.000E+00 0.000E+00 0.000E+00 0.000E+00 0.000E+00 0.000E+00 0.000E+00 | 1.000E-03 0.000E+00 | 0.000E+00
1.425E+03 | | 0.000E+00 0.000E+00 0.000E+00 0.000E+00 6.650E+02 0.000E+00 0.000E+00 0.000E+00 | 1.791E-01 0.000E+00 | 0.000E+00
1.959E+01 | | 0.000E+00 0.000E+00 0.000E+00 0.000E+00 0.000E+00 0.000E+00 0.000E+00 0.000E+00 | 0.000E+00 5.730E+01 | 0.000E+00
4.459E-01 | | -2.134E-06 9.048E-01 0.000E+00 0.000E+00 0.000E+00 0.000E+00 0.000E+00 0.000E+00 | 0.000E+00 -2.092E-01 | 0.000E+00
-2.091E-01 | | -4.269E-07 -4.243E-01 0.000E+00 0.000E+00 0.000E+00 0.000E+00 0.000E+00 0.000E+00 | 0.000E+00 -4.459E-01 | 0.000E+00
```

[lines deleted]

```
----- Azimuth = 270.00 deg -----
op State | op | A - State | B - Input | Bd - Dstrb
Derivatives | States | Matrix | Matrix | Matrix
2.143E+00 | 3.142E+00 | 0.000E+00 0.000E+00 0.000E+00 0.000E+00 1.000E+00 0.000E+00 0.000E+00 0.000E+00 | 0.000E+00 0.000E+00 | 0.000E+00
-6.944E-02 | 4.126E-01 | 0.000E+00 0.000E+00 0.000E+00 0.000E+00 0.000E+00 1.000E+00 0.000E+00 0.000E+00 | 0.000E+00 0.000E+00 | 0.000E+00
2.108E-01 | 5.462E-01 | 0.000E+00 0.000E+00 0.000E+00 0.000E+00 0.000E+00 1.000E+00 0.000E+00 0.000E+00 | 0.000E+00 0.000E+00 | 0.000E+00
-1.409E-01 | 6.073E-01 | 0.000E+00 0.000E+00 0.000E+00 0.000E+00 0.000E+00 1.000E+00 0.000E+00 0.000E+00 | 0.000E+00 0.000E+00 | 0.000E+00
2.973E-05 | 2.143E+00 | 8.486E-04 1.374E-01 1.379E-01 1.373E-01 1.021E-01 6.150E-03 9.160E-03 6.822E-03 | -3.027E-05 1.795E+00 | -4.572E-03
5.245E-01 | -6.944E-02 | -3.978E-01 -7.029E+01 -3.577E+00 -3.560E+00 -6.344E+01 -6.790E+00 -2.369E-01 -1.769E-01 | 7.851E-04 -7.094E+02 | 1.113E+01
-1.025E-01 | 2.108E-01 | 5.913E+00 -3.563E+00 -7.069E+01 -3.559E+00 -8.454E+01 -1.609E-01 -8.656E+00 -1.756E-01 | 7.852E-04 -8.561E+02 | 1.272E+01
-4.959E-01 | -1.409E-01 | -6.108E+00 -3.565E+00 -3.577E+00 -7.011E+01 -7.481E+01 -1.555E-01 -2.372E-01 -7.050E+00 | 7.845E-04 -7.755E+02 | 1.121E+01
```

```
op Output | This column | C - Output | D - Trnsmt | Dd - DTsmt
Measurmnts | is blank | Matrix | Matrix | Matrix
7.957E+00 | | 0.000E+00 0.000E+00 0.000E+00 0.000E+00 0.000E+00 0.000E+00 0.000E+00 0.000E+00 | 1.000E-03 0.000E+00 | 0.000E+00
1.425E+03 | | 0.000E+00 0.000E+00 0.000E+00 0.000E+00 6.650E+02 0.000E+00 0.000E+00 0.000E+00 | 1.791E-01 0.000E+00 | 0.000E+00
1.959E+01 | | 0.000E+00 0.000E+00 0.000E+00 0.000E+00 0.000E+00 0.000E+00 0.000E+00 0.000E+00 | 0.000E+00 5.730E+01 | 0.000E+00
3.734E-01 | | -4.269E-07 9.048E-01 0.000E+00 0.000E+00 0.000E+00 0.000E+00 0.000E+00 0.000E+00 | 0.000E+00 -1.751E-01 | 0.000E+00
-1.751E-01 | | 1.921E-06 -4.243E-01 0.000E+00 0.000E+00 0.000E+00 0.000E+00 0.000E+00 0.000E+00 | 0.000E+00 -3.734E-01 | 0.000E+00
```

Figure 31. Sample linearization model file.

This summary information was generated by FAST (v6.00c-jmj, 15-Apr-2005) on 15-Apr-2005 at 16:37:53.

FAST certification Test #01: AWT-27CR2 with many DOFs with fixed yaw error and steady wind.

Turbine features:

```

                Downwind, two-bladed rotor with teetering hub.
                Rigid foundation.
                The model has 13 of 22 DOFs active (enabled) at start-up.
Enabled      First flapwise blade mode DOF.
Enabled      Second flapwise blade mode DOF.
Enabled      Edgewise blade mode DOF.
Enabled      Rotor-teeter DOF.
Enabled      Drivetrain rotational-flexibility DOF.
Enabled      Generator DOF.
Disabled     Rotor-furl DOF.
Disabled     Tail-furl DOF.
Disabled     Yaw DOF.
Enabled      First tower fore-aft bending-mode DOF.
Enabled      Second tower fore-aft bending-mode DOF.
Enabled      First tower side-to-side bending-mode DOF.
Enabled      Second tower side-to-side bending-mode DOF.
Disabled     Platform horizontal surge translation DOF.
Disabled     Platform horizontal sway translation DOF.
Disabled     Platform vertical heave translation DOF.
Disabled     Platform roll tilt rotation DOF.
Disabled     Platform pitch tilt rotation DOF.
Disabled     Platform yaw rotation DOF.
Enabled      Computation of aerodynamic loads.
Disabled     Computation of aeroacoustics.

```

Time steps:

```

Structural      (s)      0.00400000
Aerodynamic     (s)      0.00400000

```

Some calculated parameters:

```

Hub-Height      (m)      42.672
Flexible Tower Length (m)  41.980
Flexible Blade Length (m)  12.573

```

Rotor mass properties:

```

Rotor Mass      (kg)      2200.608
Rotor Inertia   (kg-m^2)   41755.996
                Blade 1      Blade 2
                -----      -----
Mass            (kg)      435.304      435.304
Second Mass Moment (kg-m^2) 15434.709      15434.709
First Mass Moment (kg-m)   2120.280      2120.280
Center of Mass   (m)      4.871        4.871

```

Additional mass properties:

```

Tower-top Mass   (kg)      7216.038
Tower Mass       (kg)      36907.137
Turbine Mass     (kg)      44123.176
Mass Incl. Platform (kg)   44123.176

```

Figure 32. Sample summary file.

```

Interpolated tower properties:
Node TwFract  HNodes DHNodes TMassDen  FASTiff  SSStiff
(-)    (-)      (m)     (m)       (kg/m)   (Nm^2)   (Nm^2)
  1    0.024   1.000   1.999     879.160  1.564E+10 1.564E+10
  2    0.071   2.999   1.999     879.160  1.564E+10 1.564E+10
  3    0.119   4.998   1.999     879.160  1.564E+10 1.564E+10

[lines deleted]

 19    0.881   36.982  1.999     879.160  1.564E+10 1.564E+10
 20    0.929   38.981  1.999     879.160  1.564E+10 1.564E+10
 21    0.976   40.980  1.999     879.160  1.564E+10 1.564E+10

Interpolated blade 1 properties:
Node BlFract  RNodes DRNodes AeroCent  StrcTwst  BMassDen  FlpStff  EdgStff
(-)   (-)    (m)     (m)       (-)       (deg)     (kg/m)   (Nm^2)   (Nm^2)
  1    0.050   1.813   1.257     0.250    10.500    58.496   2.760E+07 8.618E+07
  2    0.150   3.070   1.257     0.250    10.404    49.105   1.582E+07 9.772E+07
  3    0.250   4.327   1.257     0.250     9.852    48.912   1.043E+07 1.065E+08
  4    0.350   5.585   1.257     0.250     9.096    42.735   6.827E+06 8.982E+07
  5    0.450   6.842   1.257     0.250     7.692    36.024   4.463E+06 6.640E+07
  6    0.550   8.099   1.257     0.250     5.613    30.272   2.821E+06 4.508E+07
  7    0.650   9.356   1.257     0.250     3.575    24.996   1.677E+06 2.751E+07
  8    0.750  10.614  1.257     0.250     1.990    20.925   8.835E+05 1.819E+07
  9    0.850  11.871  1.257     0.250     1.012    16.201   3.821E+05 9.658E+06
 10    0.950  13.128  1.257     0.250     0.395     9.536   1.030E+05 2.780E+06

Interpolated blade 2 properties:
Node BlFract  RNodes DRNodes AeroCent  StrcTwst  BMassDen  FlpStff  EdgStff
(-)   (-)    (m)     (m)       (-)       (deg)     (kg/m)   (Nm^2)   (Nm^2)
  1    0.050   1.813   1.257     0.250    10.500    58.496   2.760E+07 8.618E+07
  2    0.150   3.070   1.257     0.250    10.404    49.105   1.582E+07 9.772E+07
  3    0.250   4.327   1.257     0.250     9.852    48.912   1.043E+07 1.065E+08
  4    0.350   5.585   1.257     0.250     9.096    42.735   6.827E+06 8.982E+07
  5    0.450   6.842   1.257     0.250     7.692    36.024   4.463E+06 6.640E+07
  6    0.550   8.099   1.257     0.250     5.613    30.272   2.821E+06 4.508E+07
  7    0.650   9.356   1.257     0.250     3.575    24.996   1.677E+06 2.751E+07
  8    0.750  10.614  1.257     0.250     1.990    20.925   8.835E+05 1.819E+07
  9    0.850  11.871  1.257     0.250     1.012    16.201   3.821E+05 9.658E+06
 10    0.950  13.128  1.257     0.250     0.395     9.536   1.030E+05 2.780E+06

```

Figure 32. Sample summary file (concluded).

This file was generated by AeroDyn(12.56, 24-Sep-2003) in FAST (v4.31, 03-Oct-2003) on 03-Oct-2003 at 16:08:06.

Inputs read in from aerodyn.ipt:

```

AWT-27CR aerodynamic parameters for FAST certification test #1.
SI                Units for input and output
BEDDOES   Dynamic stall model                [Beddoes]
NO_CM       Aerodynamic pitching moment model [NO Pitching Moments calculated]
DYNIN       Inflow model                      [Dynamic Inflow]
SWIRL       Induction factor model            [Normal and Radial flow induction factors calculated]
0.005       Convergence tolerance for induction factor
[Not Used]  Tip-loss model
[Not Used]  Hub-loss model
"Wind/AWT27/Shr12_30.wnd" is the Hub-height wind file
42.672      Wind reference (hub) height, m
0.3         Tower shadow centerline velocity deficit
1           Tower shadow half width, m
2.432       Tower shadow reference point, m
1.225       Air density, kg/m^3
1.4639e-5   Kinematic air viscosity, m^2/'sec
0.004       Time interval for aerodynamic calculations, sec
10          Number of airfoil files used. Files listed below:
"AeroData/AWT27/AWT27_05.dat"
"AeroData/AWT27/AWT27_15.dat"
"AeroData/AWT27/AWT27_25.dat"
"AeroData/AWT27/AWT27_35.dat"
"AeroData/AWT27/AWT27_45.dat"
"AeroData/AWT27/AWT27_55.dat"
"AeroData/AWT27/AWT27_65.dat"
"AeroData/AWT27/AWT27_75.dat"
"AeroData/AWT27/AWT27_85.dat"
"AeroData/AWT27/AWT27_95.dat"
10          Number of blade elements per blade
RELM(m)     Twist (deg)   Number of DR(m)   Chord(m)   File ID   Elem Data RELM and Twist ignored by ADAMS (but placeholders must be present)
1.81265     5.8             1.2573            0.859      1
3.07        5.2             1.2573            1.045      2
4.32725     4.66            1.2573            1.145      3
5.58455     3.73            1.2573            1.124      4
6.84185     2.64            1.2573            1.054      5
8.1         1.59            1.2573            0.976      6
9.35645     0.73            1.2573            0.885      7
10.61375    0.23            1.2573            0.775      8
11.87105    0.08            1.2573            0.651      9
13.12835    0.03            1.2573            0.493      10

Hub-height wind file info:
Initial horizontal wind speed = 12 mps
Initial wind direction       = 30 deg
Initial vertical wind speed   = 0 mps
Initial horiz. wind shear coeff. = 0
Initial power law vert. wind shear coeff. = 0.2
Initial linear vert. wind shear coeff. = 0
Initial gust wind speed       = 0 mps

BEDDOES DYNAMIC STALL PARAMETERS:

CN SLOPE      6.0090    6.0190    6.0280    6.0340    6.1280    6.2040    6.2710    6.2580    6.1560    6.1180
STALL CN (UPPER) 1.8090    1.8130    1.8170    1.8200    1.7430    1.6770    1.6180    1.7910    1.7490    1.8400
STALL CN (LOWER) -1.0000   -1.0000   -1.0000   -1.0000   -1.0000   -1.0000   -1.0000   -1.0000   -1.0000   -1.0000
ZERO LIFT AOA  -4.2450   -4.2560   -4.2730   -4.2850   -3.2970   -2.4840   -1.7820   -1.4010   -1.2780   -1.2320
MIN DRAG AOA    0.0000    0.0000    0.0000    0.0000    0.0000    0.0000    0.0000    0.0000    0.0000    0.0000
MIN DRAG COEFF  0.0107    0.0101    0.0094    0.0090    0.0080    0.0071    0.0064    0.0062    0.0064    0.0065

VORTEX TRANSIT TIME FROM LE TO TE 11.00000
PRESSURE TIME CONSTANT 1.700000
VORTEX TIME CONSTANT 6.000000
F-PARAMETER TIME CONSTANT 3.000000

```

Figure 33. Sample AeroDyn options file.

REFERENCES

1. Laino, D.J.; Hansen, A.C. "User's Guide to the Wind Turbine Dynamics Computer Software AeroDyn." Salt Lake City, Utah: Windward Engineering, LC, August 2001.
2. Bossanyi, E.A. "GH Bladed Version 3.6 User Manual." Document 282/BR/010 Issue 12. Garrad Hassan and Partners Limited, 2003.
3. Manjock, A. "Evaluation Report: Design Codes FAST and ADAMS® for Load Calculations of Onshore Wind Turbines." Report No. 72042. Humburg Germany: Germanischer Lloyd WindEnergie GmbH, May 26, 2005.
4. Wilson, R.E.; Walker, S.N.; Heh, P. "Technical and User's Manual for the FAST_AD Advanced Dynamics Code." OSU/NREL Report 99-01. Corvallis, Oregon: Oregon State University, May 1999.
5. Buhl, Jr. M.L.; Wright, A.D.; Pierce, K.G. "FAST_AD Code Verification: A Comparison to ADAMS." *The 20th ASME Wind Energy Symposium, Reno, Nevada, January 8–11, 2001*. NREL/CP-500-28848. Golden, Colorado: National Renewable Energy Laboratory, 2001.
6. Jonkman, J.M.; Buhl, Jr. M.L. "New Development's for the NWTC's FAST Aeroelastic HAWT Simulator." *The 23rd ASME Wind Energy Symposium, Reno, Nevada, January 5–8, 2004*. NREL/CP-500-35077. Golden, Colorado: National Renewable Energy Laboratory, 2004.
7. Buhl, Jr. M.L. "Installing NWTC Design Codes on PCs Running Windows NT®." National Renewable Energy Laboratory, <http://wind.nrel.gov/designcodes/papers/setup.pdf>. Last modified Dec. 22, 2000; accessed April 5, 2002. NREL/EP-500-29384. Golden, Colorado.
8. IEC/TS 61400-13 ed. 1 "Wind Turbine Generator Systems – Part 13: Measurement of Mechanical Loads." International Electrotechnical Commission (IEC), 2001.
9. Buhl Jr., M.L. "A Simple Mode-Shape Generator for Both Towers and Rotating Blades." *NWTC Design Codes (Modes)*, <http://wind.nrel.gov/designcodes/preprocessors/modes/>. Last modified April 29, 2002; accessed July 9, 2002.
10. Malcolm, D.J. "How a Teetered Rotor with Delta-3 Really Works." *The 2000 ASME Wind Energy Symposium, January 10–13, 2000, Reno, Nevada*. New York, New York: American Institute of Aeronautics and Astronautics, 2000.
11. Stol, K.A.; Bir, G.S. "SymDyn User's Guide," NREL/EL-500-33845. Golden, Colorado: National Renewable Energy Laboratory, 2003.
12. Elliot, A.S.; Wright, A.D. "ADAMS/WT User's Guide," http://wind.nrel.gov/designcodes/simulators/adamswt/docs_v2.0/index.html. Last modified December, 1998; accessed June 13, 2003.
13. Laino, D.J.; Hansen, A.C. "User's Guide to the Computer Software Routines AeroDyn Interface for ADAMS®." Salt Lake City, Utah: Windward Engineering, LC, September 2001.
14. Laino, D., "IECWind: A Program to Create IEC Wind Data Files." *NWTC Design Codes (IECWind)*, <http://wind.nrel.gov/designcodes/preprocessors/iecwind/>. Last modified June 19, 2001; accessed July 9, 2002.
15. Laino, D., "WindMaker: A Program to Create IEC Wind Data Files." *NWTC Design Codes (WindMaker)*, <http://wind.nrel.gov/designcodes/preprocessors/windmaker/>. Last modified May 12, 2000; accessed July 9, 2002.
16. Jonkman, B.J.; Buhl Jr., M.L. "TurbSim User's Guide," <http://wind.nrel.gov/designcodes/preprocessors/turbsim/turbsim.pdf>. Last modified May 26, 2005; accessed August 11, 2005.
17. Buhl Jr., M.L. "SNwind User's Guide," <http://wind.nrel.gov/designcodes/preprocessors/snwind/snwind.pdf>. Last modified October 22, 2001; accessed July 9, 2002.
18. Kelley, N.D., "SNLWIND-3D: A Stochastic, Full-Field, Turbulent-Wind Simulator for Use with BLADED and the Aerodyn-Based Design Codes (YawDyn, FAST_AD, and ADAMS®)." *NWTC Design Codes (SNLWIND-3D)*, <http://wind.nrel.gov/designcodes/preprocessors/snlwind3d/>. Last modified July 20, 2000; accessed July 9, 2002.
19. Moriarty, P.J.; Migliore, P.G. "Semi-Emperical Aeroacoustic Noise Prediction Code for Wind Turbines", NREL/TP-500-34478. Golden, Colorado: National Renewable Energy Laboratory, 2003.

REPORT DOCUMENTATION PAGE

Form Approved
OMB No. 0704-0188

The public reporting burden for this collection of information is estimated to average 1 hour per response, including the time for reviewing instructions, searching existing data sources, gathering and maintaining the data needed, and completing and reviewing the collection of information. Send comments regarding this burden estimate or any other aspect of this collection of information, including suggestions for reducing the burden, to Department of Defense, Executive Services and Communications Directorate (0704-0188). Respondents should be aware that notwithstanding any other provision of law, no person shall be subject to any penalty for failing to comply with a collection of information if it does not display a currently valid OMB control number.

PLEASE DO NOT RETURN YOUR FORM TO THE ABOVE ORGANIZATION.

1. REPORT DATE (DD-MM-YYYY) October 2005		2. REPORT TYPE Technical Report		3. DATES COVERED (From - To)	
4. TITLE AND SUBTITLE FAST User's Guide—Updated August 2005			5a. CONTRACT NUMBER DE-AC36-99-GO10337		
			5b. GRANT NUMBER		
			5c. PROGRAM ELEMENT NUMBER		
6. AUTHOR(S) J.M. Jonkman and M.L. Buhl, Jr.			5d. PROJECT NUMBER NREL/TP-500-38230		
			5e. TASK NUMBER WER5.3115		
			5f. WORK UNIT NUMBER		
7. PERFORMING ORGANIZATION NAME(S) AND ADDRESS(ES) National Renewable Energy Laboratory 1617 Cole Blvd. Golden, CO 80401-3393				8. PERFORMING ORGANIZATION REPORT NUMBER NREL/TP-500-38230	
9. SPONSORING/MONITORING AGENCY NAME(S) AND ADDRESS(ES)				10. SPONSOR/MONITOR'S ACRONYM(S) NREL	
				11. SPONSORING/MONITORING AGENCY REPORT NUMBER	
12. DISTRIBUTION AVAILABILITY STATEMENT National Technical Information Service U.S. Department of Commerce 5285 Port Royal Road Springfield, VA 22161					
13. SUPPLEMENTARY NOTES					
14. ABSTRACT (Maximum 200 Words) The FAST (Fatigue, Aerodynamics, Structures, and Turbulence) Code is a comprehensive aeroelastic simulator capable of predicting both the extreme and fatigue loads of two- and three-bladed horizontal-axis wind turbines (HAWTs). This document covers the features of FAST and outlines its operating procedures.					
15. SUBJECT TERMS FAST; Fatigue, Aerodynamics, Structures, and Turbulence; aeroelastic simulator; horizontal-axis wind turbine					
16. SECURITY CLASSIFICATION OF:			17. LIMITATION OF ABSTRACT UL	18. NUMBER OF PAGES	19a. NAME OF RESPONSIBLE PERSON
a. REPORT Unclassified	b. ABSTRACT Unclassified	c. THIS PAGE Unclassified			19b. TELEPHONE NUMBER (Include area code)

Standard Form 298 (Rev. 8/98)
Prescribed by ANSI Std. Z39.18