

Coated Conductor Technology Development Roadmap

Priority Research & Development
Activities Leading to Economical
Commercial Manufacturing

August 2001

Sponsored by:
U.S. Department of Energy
Superconductivity for Electric Systems Program

Prepared by:
Energetics, Incorporated

About This Roadmap

The U.S. Department of Energy's Superconductivity for Electric Systems Programs sponsored a workshop that brought together a broad range of experts from industry, universities, and the national laboratories. This roadmap, which summarizes the insights of 90 workshop participants, sets forth the R&D agenda and specific near-term activities needed to advance techniques for continuous processing of high-quality, low-cost coated conductors that will lead to industrial-scale commercial manufacturing. Achievement of this agenda will enable the availability of the quality and quantity of high-temperature superconducting coated conductors that meet the application requirements of electric power systems

The workshop was organized by Energetics, Incorporated with the help of Oak Ridge National Laboratory, Los Alamos National Laboratory and Argonne National Laboratory. The workshop was facilitated by Howard Lowitt, Richard Scheer, Melissa Eichner, and Joseph Badin of Energetics, Incorporated. This roadmap was compiled and prepared by Joseph Badin. Recognition and appreciation is extended to the many participants and reviewers for committing their valuable expertise, time, and resources.

Disclaimer

The report was prepared as an account of work sponsored by an agency of the United States Government. Neither the United States Government, nor any agency thereof, nor any of their employees make any warranty, expressed or implied, or assume any legal liability or responsibility for the accuracy, completeness, or usefulness of any information, apparatus, product, or process disclosed, or represent that its use would not infringe privately owned rights. Reference herein to any specific commercial product, process, or service by trade name, trademark, manufacturer, or otherwise does not necessarily constitute or imply its endorsement, recommendation, or favoring by the United States Government or any agency thereof. The views and opinions of authors expressed herein do not necessarily state or reflect those of the United States Government or any agency thereof.

Coated Conductor Technology Development Roadmap

Priority Research & Development Activities Leading to Economic Commercial Manufacturing

Table of Contents

| | |
|--|-----------|
| Executive Summary | ii |
| 1.0 Introduction | 1 |
| 1.1 Vision | 4 |
| 1.2 Priority Production Scale-Up Issues | 5 |
| 1.2.1 Superconducting Film Thickness..... | 6 |
| 1.2.2 Film Deposition Rates..... | 7 |
| 2.0 Materials Issues | 9 |
| 2.1 Substrate Surfaces..... | 9 |
| 2.2 IBAD Template Film | 9 |
| 2.3 RABiTS Template Film..... | 10 |
| 2.4 ISD Template Film..... | 10 |
| 2.5 YBCO Deposition..... | 10 |
| 2.6 YBCO Structure – Property Relationships | 11 |
| 2.7 Grain Boundaries | 11 |
| 2.8 Precipitates..... | 11 |
| 3.0 Processing Options and Manufacturing Systems | 13 |
| 3.1 Options for Preparing Textured Substrates | 13 |
| 3.2 Options for Applying HTS Materials Onto Textured Substrates..... | 17 |
| 4.0 Process-Related Technical Issues | 26 |
| 5.0 Priority R&D Activities | 28 |
| • Fabrication Pathways | 31 |
| • Substrate Development and Characterization..... | 32 |
| • Simplified Buffer Layer Architecture | 33 |
| • Improved YBCO Quality..... | 34 |
| • Achieve Faster Deposition Rates | 35 |
| • Process Monitoring and Control Strategies/Methods | 36 |
| • Conductor Characterization | 37 |
| • Production Scale-Up (Industry-Led)..... | 38 |
| • End-User Applications (Industry-Led) | 39 |
| 6.0 The Road Ahead | 40 |
| 7.0 References | 41 |

Executive Summary

This *Roadmap* defines a near-term research and development agenda to evaluate, demonstrate, and accelerate processing, fabrication, and manufacturing of high-temperature superconducting (HTS) coated conductors that meet the needs of the U.S. electric power industry. Advanced power equipment containing HTS components has the potential to revolutionize the nation's electric power systems. Superconductivity will need to play a significant role if America is to continue to have affordable and reliable electricity.

Enormous strides have been made in conductor development for the application of superconductivity to electric power systems. Recent achievements of critical currents exceeding 1 MA/cm^2 at 77K in YBCO deposited over suitably textured substrates have stimulated interest in potential applications of coated conductors at high temperatures and high magnetic fields. This superior performance has been shown in small laboratory samples of coated high-temperature superconductors. Efforts are focused on scaling-up the processing on a continuous basis while minimizing any degradation of wire performance.

The major issues for economical manufacturing of long-length YBCO-coated conductors pertain to developing a capability for continuously and uniformly depositing buffer layer(s), conductor and barrier layer coatings with correct orientation at high rates over large area substrates. Of course such a capability for the conductor has to meet the very important YBCO requirements of proper stoichiometric composition and epitaxial growth with biaxial texture.

This *Roadmap* examines materials-related issues and processing and manufacturing issues. Continuous manufacturing of long wires or tapes will require reel-to-reel type of processing and will consist of at least the following operations:

- preparation of substrate material;
- preparation and application of the seed and buffer layer(s);
- preparation and application of the HTS material and required post-annealing, and;
- preparation and application of the passivation/stabilization/insulation layer.

Each of these operations presents its own set of target opportunities and priority R&D needs. The *Roadmap* presents the priority R&D needs in the following activity areas.

- Fabrication Pathways
- Substrate Development and Characterization
- Simplified Buffer Layer Architecture
- Improved YBCO Quality
- Faster Deposition Rates
- Process Monitoring and Control Strategies/Methods
- Production Scale-Up (Industry-Led)
- End-User Applications (Industry-Led)

Exhibit ES-1 shows a flow chart of the major operations aligned with the major categories of coated conductor R&D activities. For each of the areas listed above, the *Roadmap* links R&D needs and knowledge gaps to performance targets in 2005 and industry needs in 2010.

Exhibit ES-1 HTS Coated Conductor Development and Manufacture

General Continuous Manufacturing Operations

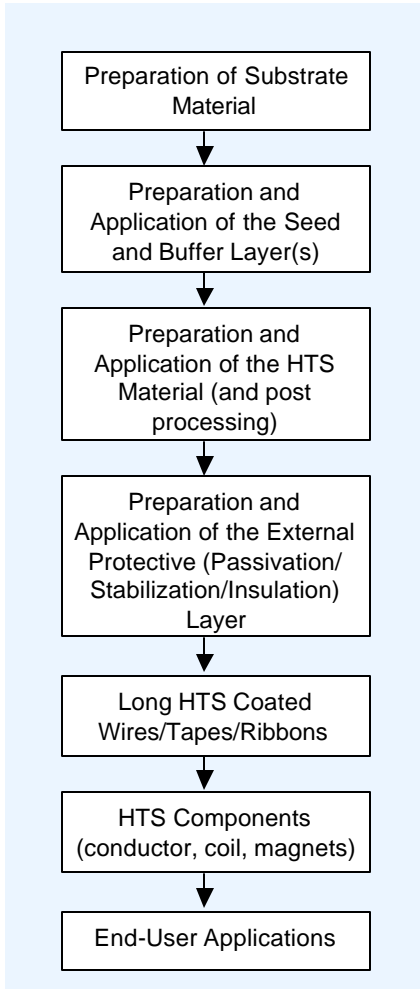

Coated Conductor Development Activities

Fabrication Pathways

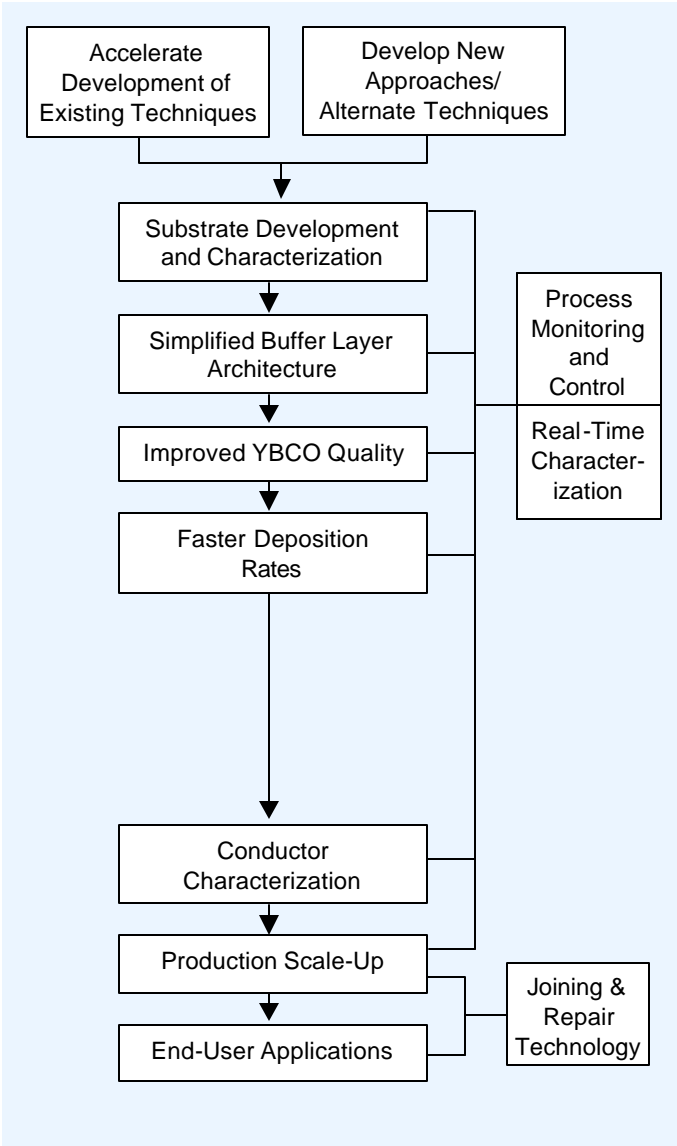

Numerous interrelationships exist among the issues discussed in the *Roadmap*. Partnerships between the superconducting wire manufacturers, equipment developers and manufacturers, and end-users, such as electric utilities and other electricity suppliers, will be critical to successfully meeting the challenges. Technology advancement plays an important role in lowering production costs and creating innovative new products. The successful achievement of this R&D agenda will require the combined talents of industry, academia, and government.

Continuous processing needs to be set up at the national laboratories so they can act as the advance team or “technology scouts” to reduce risks and costs to the private sector. Expertise and capabilities need to be transferred to private companies. The national laboratories develop the scientific and materials processing understanding underlying the technology. The laboratories strengthen and expand their capabilities by working with universities in research aimed at addressing fundamental technological issues. The laboratories also work closely with industry by providing access to facilities and equipment and by arranging technical personnel exchanges. Successful technology transfer requires a team effort from national laboratory facilities and industry. For example, both Oak Ridge National Laboratory and Los Alamos National Laboratory have set up separate high quality laboratory spaces for use by DOE laboratories and their industrial partners. The laboratories will develop new equipment needed for more rapid preparation and characterization of coated conductors. Industry will take the lead in any subsequent production scale-up activities as well as activities aimed at satisfying end-user application needs in the commercial marketplace.

The research priorities outlined in this *Roadmap* will be used as the basis for making new research investments by government and industry. However, the *Roadmap* is a dynamic document that will be reevaluated at regular intervals to incorporate new market and technical information and to ensure that the research priorities remain relevant to the needs of industry and the electric utilities.

1.0 Introduction

Enormous strides have been made in conductor development for the application of superconductivity to electric power systems. The recent demonstration of record superconducting performance in conductors prepared by coating thick films of $\text{YBa}_2\text{Cu}_3\text{O}_x$ (YBCO) onto flexible metallic substrates has stimulated intense worldwide activity and expectations for realizing the full potential for operating superconducting devices at liquid nitrogen temperatures with current densities in the MA/cm^2 range. The key ingredient in this new development has been the ability to deposit onto polycrystalline substrates YBCO films that are biaxially textured, thus reducing the number of weak, high angle grain boundaries that are known to limit current transport. This has been accomplished by developing two independent techniques for preparing a biaxially textured template, upon which the YBCO film is subsequently grown epitaxially. The two most advanced techniques are the ion beam-assisted deposition (IBAD) process, and the rolling-assisted biaxially textured substrate (RABiTS) process. In addition, another method referred to as inclined substrate deposition (ISD) has also emerged as a promising method for the fabrication of YBCO conductors. The processing methods are quite different in detail, but the overall final structures are rather similar.

The IBAD technique achieves biaxial texture by means of a secondary ion gun that orients an oxide film buffer layer while it is being deposited onto the polycrystalline metallic substrate. The RABiTS process achieves texture by mechanical rolling of a face-centered cubic metal and subsequent heat treatment. The ISD process achieves texture by inclining the substrate to the oxide plume. While all three processes have succeeded in achieving very high YBCO critical current densities on short samples, the development thus far has been largely empirical in nature and offers substantial opportunities for research and development activities that will establish better understanding of the many steps in the process in order to make further progress and allow commercial production on an industrial scale. Exhibits 1.1, 1.2, and 1.3 present the IBAD, RABiTS, and ISD processes, respectively.

One of the biggest hurdles to widespread application of YBCO coated conductor tape is developing a manufacturing process that will produce it in long lengths and at prices competitive to copper for applications such as motors, generators, transmission cables, and other power systems. In fact, most coated conductors have only been produced in a laboratory environment with a characteristic area of a few square centimeters. Thus, there presently is no infrastructure for making long length coated conductors, like there is to make long length powder-in-tube (PIT)-based high temperature superconductors. (PIT-based superconductors are primarily made by drawing operations, somewhat similar to the methods of producing conventional non-superconducting wire.) The coated conductors potentially have more superior performance than available first generation bismuth based HTS compounds (BSCCO), in that they can have a higher irreversibility field-temperature envelope and therefore can operate effectively at higher critical fields in the temperature range of 30-77 K. The increased performance is due to differences in materials rather than the processes, and the drawing operations cannot be used with materials employed in coated conductors. However, there are several alternative processes proposed for deposition of highly textured YBCO onto long metallic strips (i.e., coated conductors). The published literature on various schemes to form HTS films on metallic, semi-metallic, or ceramic substrates can be divided into physical methods and non-physical or

Exhibit 1.1 IBAD Substrate Preparation Method

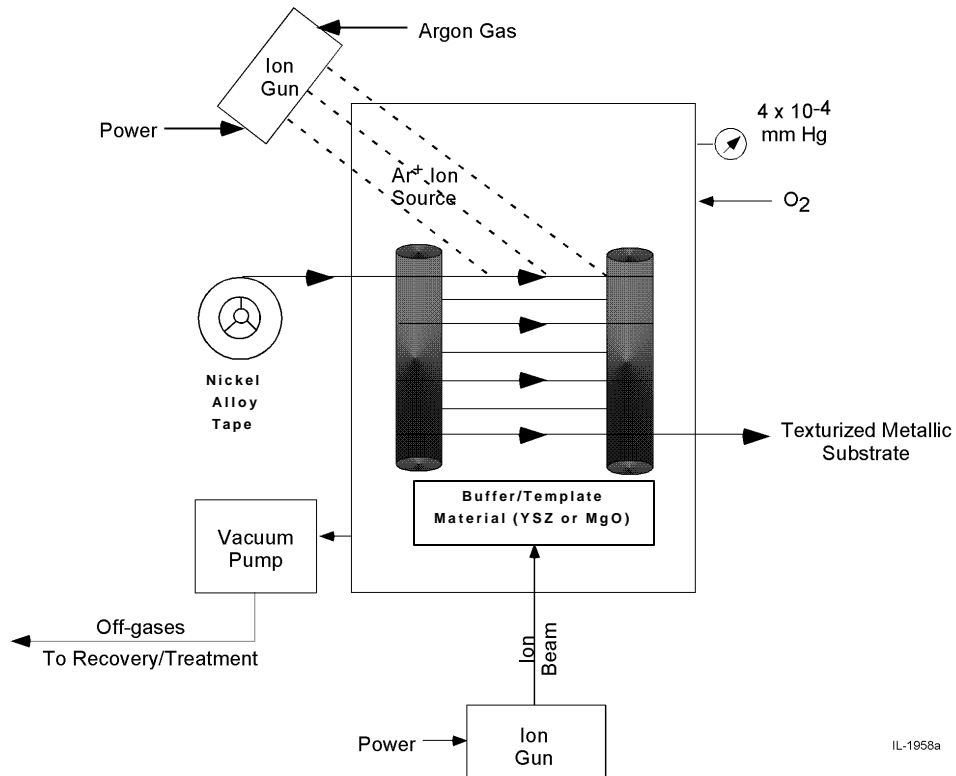

Exhibit 1.2 RABiTS Substrate Preparation Method and Pulsed Laser-Based Buffer Deposition

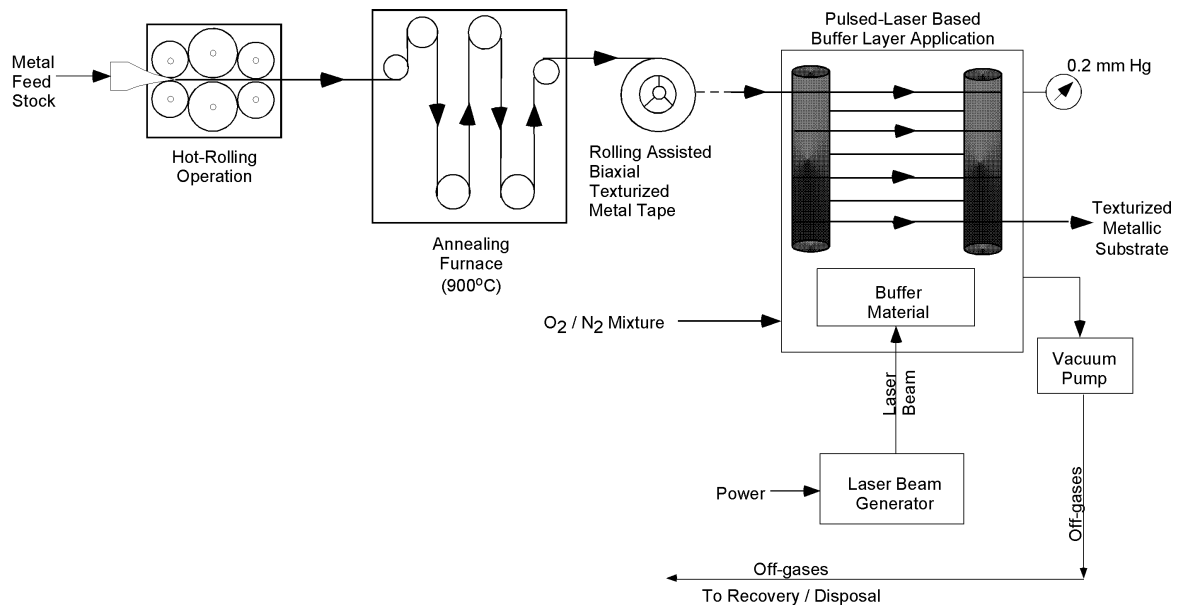
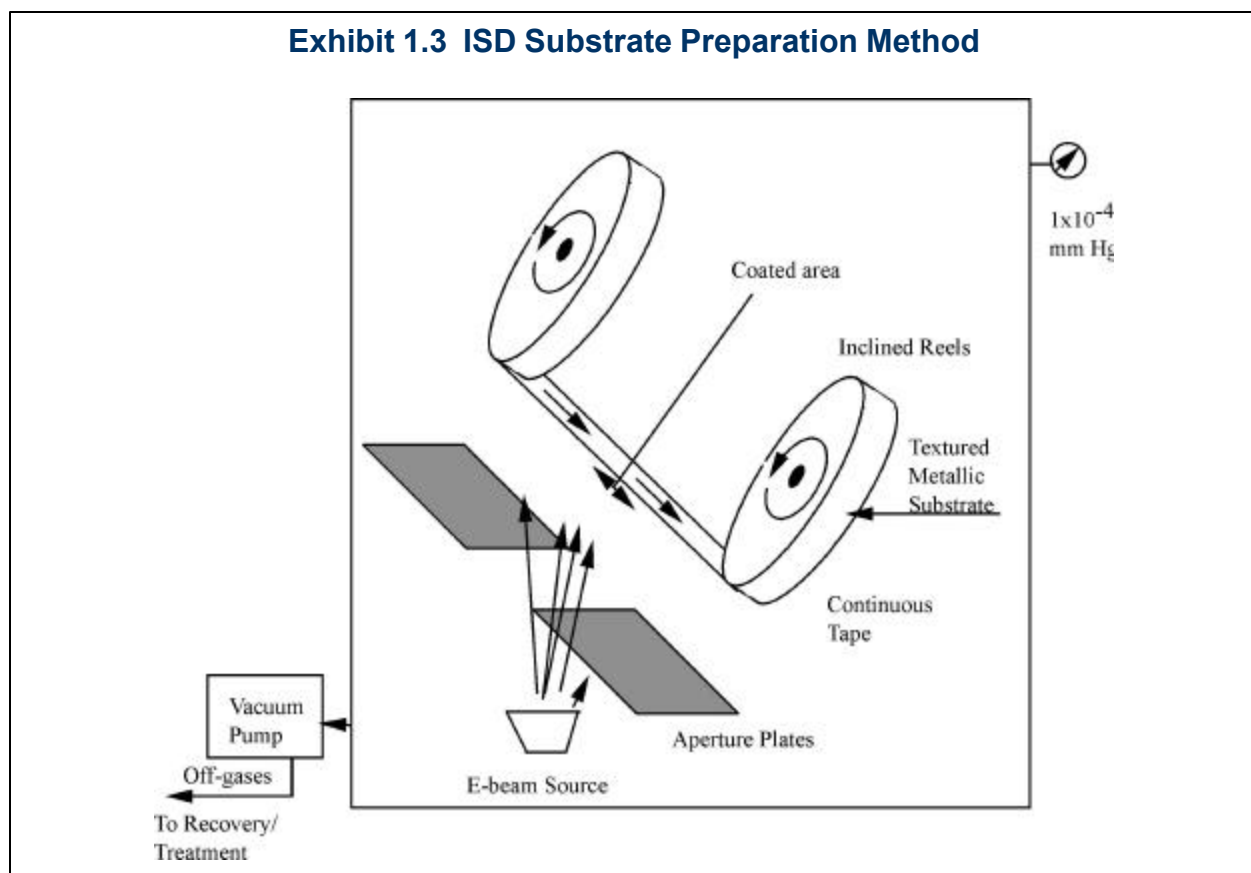

Exhibit 1.3 ISD Substrate Preparation Method



chemical methods as shown in the table below. Conceptual manufacturing schemes that include the following methods are discussed in Section 3.

Methods to Form HTS Films on Substrates

| Physical Methods | Chemical Methods |
|---|--|
| <ul style="list-style-type: none"> • Pulsed Laser Ablation/Deposition (PLA/PLD) • Electron Beam–Based Deposition • Electrophoresis • Magnetron Beam-Based Deposition • Thermal Evaporation • Sputtering | <ul style="list-style-type: none"> • Sol-Gel • Chemical Vapor Deposition (CVD) • Metal Organic Chemical Vapor Deposition (MOCVD) • Metal Organic Decomposition (MOD) • Electrodeposition • Aerosol/Spray Pyrolysis |

Except for the electrophoresis technique, none of the published work started with a metal substrate on one end and ended with the coated material at the other end. In order to develop appropriate conductor coating schemes for the continuous processing/manufacturing of long wires or tapes or ribbons, additional steps that are not part of the deposition scheme need to be included. In general, a spool-to-spool or reel-to-reel type of continuous manufacturing scheme developed for any of the above techniques, would also include at least the following operations:

- Preparation of substrate material;
- Preparation and application of the seed and buffer layer(s);
- Preparation and application of the HTS material and required post-annealing; and
- Preparation and application of the external protective layer.

These four major operations are necessary because of the complete match required between the four major components of the finished HTS wires/tapes. The four major components are thus, metal substrate, buffer, HTS, and outer passivation/insulation layer. From a literature search no information was found about any work that has taken the concept from the metal substrate at one end and produced a finished insulated wire product at the other end. Most of the work described is either working with single crystals of buffer material and/or small samples of metal substrate. In order to present options for continuous processing/manufacturing of long length of coated wires, it was therefore necessary to conceptually develop schemes that would incorporate the above operating steps and enable one to produce long lengths of wire in a reel-to-reel or spool-to-spool mode, as shown in Section 3.

Exhibit 1.4 shows a flow chart of the major operations aligned with the major categories of coated conductor R&D activities. Detailed technology development roadmaps are presented in Section 5 covering the spectrum of R&D activities. The activities specified in this roadmap are focused on achieving the following vision.

1.1 VISION

Low-cost, high-performance YBCO Coated Conductors will be available in 2005 in kilometer lengths. For applications in liquid nitrogen, the wire cost will be less than \$50/kA-m, while for applications requiring cooling to temperatures of 20-60 K the cost will be less than \$30/kA-m. By 2010 the cost-performance ratio will have improved by at least a factor of four.

HTS wires based upon coatings of YBCO on textured, buffered metallic substrates will offer unprecedented current carrying capacity at high temperatures and in the presence of strong magnetic fields. Coated conductors also will be fabricated using industrially scalable deposition technologies, many of which are presently in use in the semiconductor and photographic film industries, but which have not been adapted for use in continuous processing of the templates or superconductor layers.

The U.S. will maintain its leadership position in HTS coated conductor development. U.S. industry will apply HTS devices to address critical issues in the nation's long-term energy strategy.

In the case of production of a coated conductor in long lengths, the vision explicitly presents a figure of merit composed of two measures: current capacity and cost. Any conductor will have to meet some minimal value of engineering current density where the minimum value is application specific. That is to say, it will, in general, always be desirable to maximize the engineering current density, but the minimum acceptable values will be different in the cases of a motor field winding and an underground transmission cable.

1.2 PRIORITY PRODUCTION SCALE-UP ISSUES

The YBCO material has a characteristic critical current of the order of 4×10^6 amps/cm² in self-field at 77 K when observed on epitaxial single crystals. In a polycrystalline structure, the critical current density is drastically reduced by the presence of crystal boundaries which is

Exhibit 1.4 HTS Coated Conductor Development and Manufacture

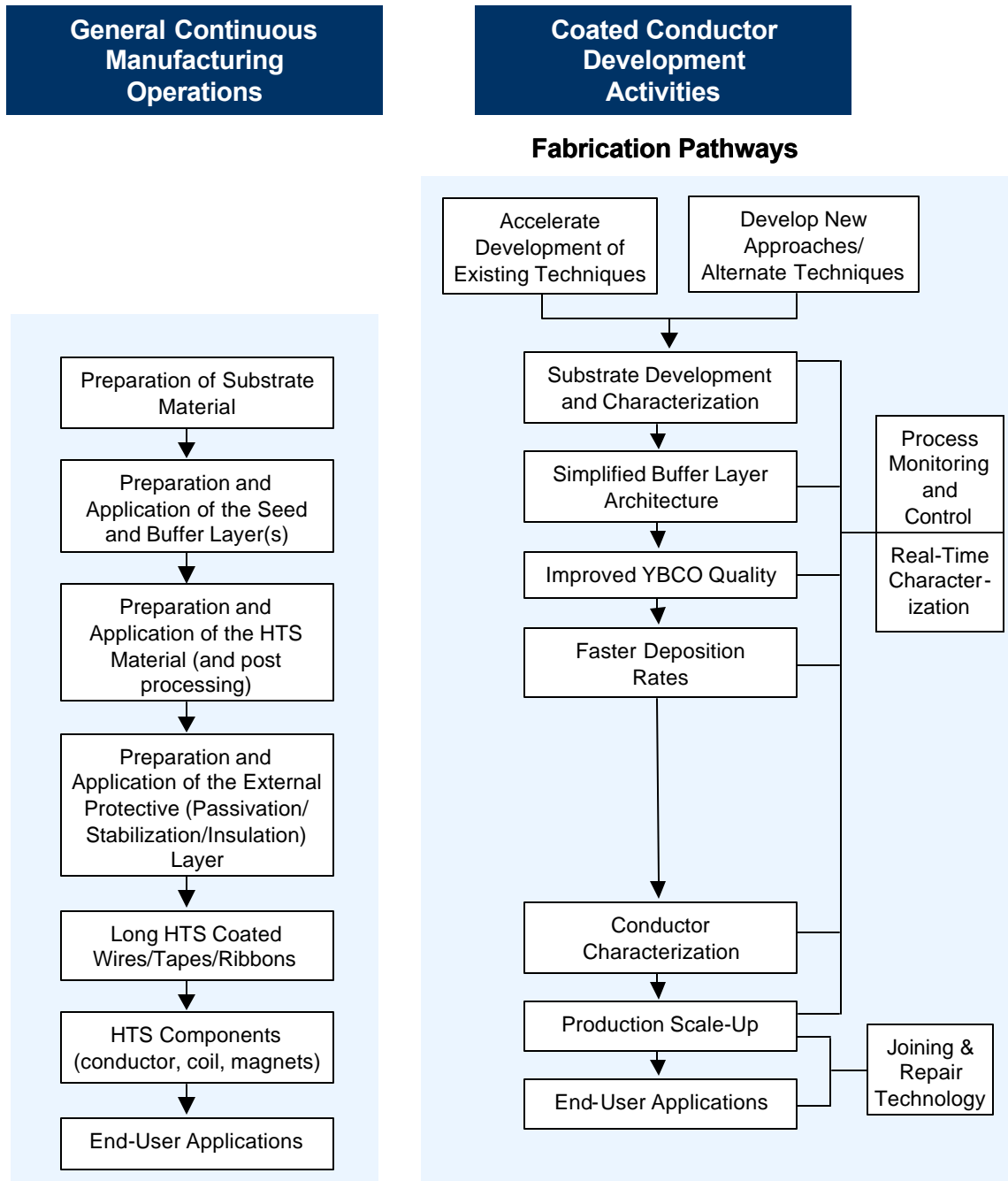

termed “weak link” behavior. In thin films, it is desired to grow the films maintaining a high texture in the film such that a highly aligned crystalline matrix having low angle grain boundaries results. When this is successfully accomplished, the film intergranular critical current density approaches the film intragranular current density. As will be more fully discussed later, the HTS films are thin, being only of the order of a few microns thick. Consequently, the films are deposited on a metallic strip for strength. It is believed that, while handling problems are obvious, the metal strip can be as thin as 1 mil (25 microns). YBCO may be subject to degradation by moisture so any thin film would require a hermetic seal as well as obvious electrical insulation. In addition, many alloy tapes will require electrical stabilization with a layer of silver or another metal overlayer. The engineering current density is the critical current divided by the total conductor (superconductor and substrates) cross sectional area. It is easy to see that when the cross sectional overhead due to the metallic substrate and environmental encapsulation is taken into account, the engineering current density is only a fraction of the superconducting material critical current density. From the outset it is therefore desirable to maximize both the critical current density of the superconducting film and the superconductor cross sectional area relative to the total conductor cross sectional area.

Two methods of maximizing the superconducting material’s cross sectional area are obvious: Increasing the film thickness and coating both sides of the metallic substrate. The latter is a complication of the manufacturing process and may require that the substrate be heated to insure proper film growth. Double-sided deposition with quartz lamp or resistive heating may be effective techniques. Increasing film thickness is not straight forward as there is evidence that the film critical current density maximizes for thicknesses of a few microns. For submicron thicknesses, or for the first fractional micron thicknesses of thick films, the critical current density is lowered due to misalignment of the crystalline ab-planes and for thick films the c-axis alignment normal to the substrate plane deteriorates. In all cases biaxial alignment, in the ab-plane and c-axis direction, is a prerequisite for high intergranular critical current density. LANL has developed a multilayer process that produces high quality thick films that are not limited to 2 microns.

The second element for assessing a candidate manufacturing process is cost. This element has many facets. Processes requiring high vacuum may be more costly than an atmospheric pressure process, and processes having many sequential operations correspondingly have increased materials costs, processing speeds, and environmental contaminants all combine to determine the final cost.

The two highest priority issues for successful production scale-up are:

- Increasing Superconducting Film Thickness while Maintaining High Current Density, and
- Increasing Film Deposition Rates or Mass Throughput While Maintaining Quality.

1.2.1 Superconducting Film Thickness

The manufacture of coated conductors requires that high quality films be deposited on substrates at high rates. The superconducting layer will be relatively “thick,” in the range of 1 to 10 micrometers, whereas buffer layers, diffusion barriers, passivation layers, etc. can be thinner. Since the thinnest commercial metal tape substrates (e.g., of oxidation-resistant nickel superalloys) are about 1 mil (25 micrometers) in thickness, it is important to have a thick

superconducting film, so that the high J_c (critical current density) translates to high J_e (engineering current density). The maximum useful thickness of the superconducting layer is not yet known. Thicker layers are more prone to fracture; they are also more prone to delamination due to differential thermal expansion during processing. However, it is clear from a number of studies that films several micrometers in thickness will be needed. A plausible cross section of a future coated conductor is a 20 micrometer metal tape, coated on both sides with seed and buffer layer(s), a 5 micrometer YBCO layer, and capped with a 0.5 micrometer passivation layer. In addition, however, alloy substrates may need a stabilization layer many tens of micrometers thick.

For YBCO of thickness higher than 5 micrometers, there are intrinsic obstacles since

- 1) a-axis grains start forming (grains with a-axis perpendicular to the substrate)
- 2) there is insufficient oxygenation as thickness increases (demonstrated in bulk samples)
- 3) defects accumulate and degrade J_c

Although the goal that a future conductor may have a 20-micrometer metal substrate with 5-micrometer YBCO films on both sides is aggressive, the desire for high technical and economic performance will eventually result in conductors with a high percentage of high- J_c superconductor in the cross section. Actual cross sections will need to be compatible with elementary stability requirements. It is known that YBCO can withstand up to 0.5% strain in tension (more in compression). Los Alamos National Laboratory has demonstrated that compressive strains of 1% and tensile strains of 0.4% are permissible. For a 30-micrometer structure, 0.5% strain corresponds to a bending radius of $(1/2)(0.03 \text{ mm})(1/0.005) = 3 \text{ mm}$, which is acceptable for most applications. Also, the LANL work, and earlier work in Japan as well show rather directly that the films on metal substrates can be bent. Future thinner metal substrates should result in increased flexibility.

1.2.2 Film Deposition Rates

Most YBCO films fabricated to date have been deposited over centimeter-sized substrates during a period of a few minutes to hours. In laboratory studies the primary concern is film quality, not deposition speed. Straightforward scale-up entails deposition on larger substrates, and increasing the power to the deposition apparatus to boost rates until film quality begins to degrade. Although it is thought that long lengths of high-performance conductor can be synthesized by these straightforward methods, a key unresolved question at the present time is whether these long lengths can be manufactured economically. If the value of a tape 1 cm wide is *roughly* \$1/meter, then a small manufacturing plant with a value of tens of millions of dollars, must produce several million meters of tape per year, to justify the investment. This areal rate of production translates to a minimum hourly rate of a few square meters per hour, in contrast with current laboratory rates of a few square centimeters per hour. Thus film deposition rates must increase by about 4 orders of magnitude. While the projected areal rate is high, the volume of superconductor to be deposited per hour will only be a few tens of cubic centimeters per hour. All requirements of deposition rate depend on the critical current density achieved.

Much of the needed gain in deposition speed can be obtained by scaling up the size of the deposition zone from a few square centimeters to a few square meters. Deposition on large areas can be followed by a slitting operation to size the tape to a final width. Alternatively, it may be advantageous to improve the specific film deposition rate (that is, the rate of film thickness

increases in dimensions of micrometers per minute), which would permit the use of a smaller deposition zone.

Small-scale laboratory deposition rates are typically only a few angstroms per second; the growth of a micrometer thick film then requires roughly an hour. Since one would like to deposit at least a few square meters per hour, the size of the deposition equipment would need to be rather large. An order of magnitude increase in deposition rate can permit the deposition chamber dimension to be reduced by a factor of 3, and the cost of the chamber correspondingly can probably fall by a factor of about 30. Thus, there is a significant incentive to increase deposition rates. For very thin buffer layers, the deposition rate may be less critical.

Each film deposition process will have some maximum rate, beyond which defects or other problems such as supplying source material or removing by-products may become limiting. For example, diffusion of the depositing atoms on the growing film surface requires time. If the deposition rate is too high, then some atoms will not have time to diffuse to their “proper” sites. Research is ongoing to determine what these maximum rates are for various processes.

A few specific examples from the published literature can indicate some of the increased rates achieved so far. For pulsed laser deposition, YBCO coatings have been formed at rates higher than 1 micrometer per minute. This is done by increasing the pulse rate of the laser. Unfortunately, the size of the laser plume is such that only a small number of square centimeters of substrate can be coated by a single laser, so that larger lasers and multiple lasers would appear to be required. LANL has already demonstrated depositing 1 micron thick films on 1 meter lengths in 4 minutes with PLD and achieving the same HTS properties. This rate correlates to 1500 square centimeters per hour. With photo-assisted MOCVD, rates on the order of 1 micrometer per minute of YBCO have also been achieved. In this case, the present high cost of the precursor metal organic compounds is an issue.

E-beam co-evaporation is believed to have considerable potential for large area deposition at high rates. This technique has coated substrates up to 9 inches in diameter with YBCO, at nominal rates of 24 nm/min. For co-evaporation, an important issue can be the accurate balance of evaporation rates from the separate Y, Ba, and Cu sources.

For relatively thick YBCO films, grown at high speed, it can be expected that oxygen annealing will require attention. In small scale growth, the films are generally cooled slowly from a high deposition temperature (above 700°C) in oxygen. During this cooling oxygen is absorbed by the films (at 400 to 500°C), and the non-superconducting tetragonal phase is converted to the superconducting orthorhombic phase. Since this oxygen diffusion can be a relatively slow process, particularly in the c-axis direction and the silver overcoat process may remove oxygen, it is anticipated that spools of YBCO tape may need to be batch annealed to ensure adequate oxygen uptake.

This roadmap identifies the priority R&D activities that address these major issues and therefore would significantly enhance progress in coated conductor development in large-scale superconducting electric power systems.

2.0 Materials Issues

The material in this section is reproduced and modified from portions of the following paper: D.K. Finnemore, et al., “Coated Conductor Development: An Assessment,” *Physica C* 320, 1999, 1-8.)

The following issues have been identified as being key to enhancing the performance and to reducing the cost of processing coated conductors to the levels that will help bring superconductivity into the marketplace.

2.1 SUBSTRATE SURFACES

The requirement of maintaining a high degree of intergrain alignment may place stringent requirements on the surface smoothness of the metallic substrate. As yet, there has been no systematic determination of the effect of surface roughness on the subsequent granular alignment of the deposited layers or of its effect on the superconducting properties of the YBCO films. This needs to be established, along with techniques for achieving the required surface smoothness over long lengths of metallic tape by economical means. Specific activities include:

- 1) Investigate the effects of controlled degrees of surface roughness on grain orientation of seed layer, buffer layers, on the YBCO layer, and on the critical current of the YBCO layer.
- 2) Develop methods for improving surface finish (planarization) with a goal of a surface roughness less than 10 nm. New methods might involve “ion beam cluster” and “sol-gel” techniques.
- 3) Determine the effects of specific surface features on metallic surfaces, on the buffer layer structure and on J_c of the deposited YBCO films.
- 4) Determine means to control the buffer layer morphology.

2.2 IBAD TEMPLATE FILM

The basic mechanism of the IBAD process is poorly understood. Deposited grains of the oxide compound that are nucleating and growing on the substrate are being bombarded by ions from the secondary gun at an angle that coincides with a special crystallographic orientation of selected grains that grow preferentially, resulting in the development of a biaxial texture. Optimum texture for the YSZ compound, when bombarded along a $\langle 111 \rangle$ axis, evolves gradually as the thickness increases, and requires film thickness near 1 μm . This is time consuming and costly. A recently discovered alternative to YSZ is MgO, which develops the same degree of texture at a thickness of only 10 nm. The process by which this texture develops has no fundamental basis of understanding. A research program would need to assess this problem. Research in this area is underway at Stanford University and at the University of Michigan.

2.3 RABITS TEMPLATE FILM

Primary issues in the future development and improvement of RABITS-based conductors include sharpness of the texture distribution along the metal or alloy strip, purity, uniformity of texture in the metal strip, epitaxy, crystallinity, adherence, and integrity of the buffer layers. Although the c-axis alignment of the superconducting layer is generally better than that of the underlying buffer layers and metal, grain boundary misorientation in the superconductor is generally determined by the misorientation distribution in the metal substrate. Strongly misaligned grains in the metal, as may result from twinning or the presence of a second texture component, lead to nonepitaxial randomly oriented (or even amorphous) regions in the buffer layers. Such regions result in high angle grain boundaries in the superconductor, and may also lead to reactions between the superconductor and the substrate.

The buffer layers have the dual functions of chemically isolating the superconductor from the metal, and transmitting the texture of the metal to the superconductor. The buffer layer structure must not chemically react to a significant degree with either the textured metal or the superconductor, and it must prevent diffusion of components of the metal to the superconductor. Both buffer layer microstructure and isolation properties are known to vary with the deposition process (sputtering or e-beam evaporation) and deposition conditions. Buffer layer architectures on which high J_c superconducting films presently have been obtained consist of two or three oxide layers. Development of an effective single layer buffer is highly desirable.

In a large portion of the work on RABITS, nickel has been used as the texture material. Highly textured metal strips are needed that are stronger than nickel both at the elevated temperatures required at some stages of conductor fabrication and at the operating temperatures of the superconducting devices. Textured metal substrates that are nonmagnetic or have substantially reduced magnetism at device operating temperatures are also desirable. Various approaches to fabrication of stronger substrates with reduced magnetism have been suggested, including composite structures and alloys.

2.4 ISD TEMPLATE FILM

ISD is a relatively new technique that holds promise as a viable technique for long-lengths because it: does not require expensive ion sources; is a room temperature process; is extremely fast, and; can be used on untextured metal substrates. Biaxial texturing of an oxide seed layer is obtained in ISD by inclining the untextured polycrystalline substrates at an angle with respect to the vapor source (e-beam, laser ablation, etc.). Unlike the IBAD process, in ISD there is no bombardment of an assisting ion gun to induce biaxial texture. It has been experimentally found that the inplane texture of the oxide seed layer deposited on hastelloy substrates by ISD is not dependent on deposition rates from 2.5 to 100 A/sec, making this technique amiable to cost-effective production scale-up. This has important implications on the manufacturing scale-up of coated conductors. More extensive film growth and microstructural studies need to be performed in order to gain a thorough understanding of the materials processing issues involved in the ISD process.

2.5 YBCO DEPOSITION

A variety of deposition techniques have been employed to deposit the 1-5 μm thick YBCO films. The properties of these films depend critically upon the microstructures that develop during the

nucleation and growth of the films. These microstructures depend on the substrate properties, the particular deposition technique, the processing conditions and the film thickness. There is yet little fundamental understanding of the nucleation and growth processes and how specific microstructures develop. Research requirements include the following.

- 1) Investigation of nucleation and growth mechanisms for all buffer layer and YBCO deposition processes. The growth conditions for desired microstructures should be determined for each deposition process and for desired layer thicknesses.
- 2) High quality films require precise control of film stoichiometry during deposition over long time intervals.
- 3) Synthesis of thin films using high fluxes of atomic oxygen. The flux of atomic oxygen can be used to grow YBCO at substantially higher rates. This is a possible route to a faster, more economical deposition process.
- 4) Alternative nonvacuum processes for fast, reliable and economic deposition of YBCO should be pursued. These include MOCVD, sol-gel and liquid phase epitaxy.

2.6 YBCO STRUCTURE – PROPERTY RELATIONSHIPS

The superconducting properties of YBCO films are determined by their microstructures. In particular, the dependence of the critical current density upon temperature, magnetic field and field orientation shows substantial variation with microstructure, which must be controlled to produce optimum values.

2.7 GRAIN BOUNDARIES

Grain boundaries in complex oxides pose particularly interesting and difficult problems whose solutions are vital to a number of practical and fundamental issues related to coated conductors specifically, and to high temperature superconductors in general. In many cases, these issues are generic to other complex electronic oxides as well, such as ferroelectrics and colossal magnetoresistive manganites as well as issues of grain boundaries in general.

Recently, coated conductors using YBCO deposited onto crystallographically oriented substrates have demonstrated remarkable successes and have emerged as its most promising method to develop practical high-current, high-field applications operating at 77K. There is a significant competition between the performance and economic cost, as related to the degree of grain orientation achieved. Coatings with large misorientations are more easily fabricated, but the resulting high-angle grain boundaries can severely limit the critical current density, J_c . Thus, a fundamental need is to evaluate and understand what controls the grain boundaries conductivity as a function of grain boundary angle. Such information can lead to possible methods to improve grain boundary performance and also suggests the degree of orientation to strive for. Both Oak Ridge National Laboratory and Los Alamos National Laboratory have defined this relationship.

2.8 PRECIPITATES

The development of low-cost processing methods that will produce a regular array of precipitates or second phase particles to act as pinning centers for the flux line lattice presents special

problems in these oxide conductors because there are so many different elements in the superconductor and because the bonding is often ionic and anisotropic. Research needs include processing research for the commercial scale production of nanoscale nonsuperconducting second phases in superconducting material grains and development of in-situ measurement techniques for on-line and real-time diagnostic studies such as environmental scanning electron microscopy, Raman and infrared spectroscopy, neutron and synchrotron-generated X-ray diffraction and scattering, and ultrasonic probes. The idea is to obtain real-time chemical and structural information about phase composition and phase transformation, oxidation states, grain and grain boundary growth processes, texture development and quality, defect formation, and impurity effects.

3.0 Processing Options and Manufacturing Systems

The material in this section is reproduced and modified from portions of the following report: “Evaluation of Methods for Application of Epitaxial Buffer and Superconductor Layers,” Topical Report, UTSI 97-02, DOE/PC/95231-11, March 1999.

In order to develop appropriate conductor coating schemes for the continuous processing/manufacturing of long wires, or tapes, or ribbons, additional steps, not previously investigated, need to be included in the different deposition processes. In general, reel-to-reel types of continuous manufacturing schemes developed out of any of the above techniques, would consist of at least the following operations

- Preparation of metal substrate material;
- Preparation and application of the seed and buffer layer(s);
- Preparation and application of the HTS material and required post-annealing, and;
- Preparation and application of the passivation/stabilization/insulation layer.

Exhibit 3.1 shows the materials and engineering related parameters to be considered for each of the four operations in continuous processing of coated conductors.

Conceptually, the manufacture of HTS thin film conductors or tapes will consist of a means of epitaxially growing the HTS on a suitable starting substrate. The substrate must provide a suitably textured surface to promote the required ordered growth of the HTS grains such that low angle grain boundaries result. This, in turn, implies that the surface lattice dimensions should approximate and be compatible with those of the HTS thin film. In addition, the substrate should possess the strength and flexibility required of a conductor and have a favorable match of its thermal expansion with that of the superconductor. The substrate material should also be thermally and chemically compatible with all of the intermediate deposition or growth processes involved in creating the superconducting film on its surface.

3.1 OPTIONS FOR PREPARING TEXTURED SUBSTRATES

Three processes for producing metallic substrates are currently being studied. In the first process, described as the Rolling Assisted Biaxially Textured Substrate (RABiTS) process, the starting metal strip is rolled and annealed to promote a textured surface as shown in Exhibit 3.2. Many metals are amenable to such mechanical texturing but the present metals of choice are high purity nickel or nickel alloys (Ni-Cr or Ni-W). A suitable buffer layer system is applied on the rolled and annealed metal strip. Although, in Exhibit 3.2 this buffer layer application is shown being carried out using pulsed laser deposition, it can equally be carried out using sputtering, electron beam evaporation, or a sol-gel process. In the literature, scientists have applied yttria stabilized zirconia (YSZ), cerium oxide (CeO_2), lanthanum aluminate (LaAlO_3), barium zirconate (BaZrO_3), and other ceramics in single constituent or multi-constituent layers to provide a buffered, textured substrate for the YBCO.

Exhibit 3.1 Important Parameters for Continuous Processing of Coated HTS Wires/Ribbons

| SUBSTRATE | | BUFFER | | SUPERCONDUCTOR | | PASSIVATION/STABILIZATION/ INSULATION COVERING | |
|--|---|--|--|--|---|--|---|
| Materials Related | Pretreatment Related | Materials Related | Application Process Related | Materials Related | Application Process Related | Materials Related | Application Process Related |
| CHEMISTRY & MATERIALS RELATED PARAMETERS | | | | | | | |
| Compatibility Mechanical Properties Availability Cost Thermal Expansion Magnetic Properties | Rolling Characteristics Texture/Orientation Annealing Surface Roughness Grain Boundary Characteristics | Compatibility Availability Thermal Expansion Chemical Stability Lattice Mismatch Need for Multi-Layers Need for More than One Buffer Cost Diffusion Barrier Oxidation Resistance | Smoothness Continuous/Semi-Continuous Biaxially Aligned Deposition Rate Coating Thickness Material Utilization | Compatibility Precursor Availability Chemical Stability Cost Thermal Expansion Lattice Mismatch Diffusion Barrier | Film Surface Quality Large-Area Coverage Deposition Rate Coating Thickness Continuous/Semi-Continuous Film Stoichiometry Texture/Orientation Achievable J_c , J_e Values Material Utilization | Compatibility Availability Mechanical Properties Cost Thermal Expansion Oxidation Resistance Electrical Properties | Smoothness Continuous/Semi-Continuous Coating Thickness Reduction in J_c |
| ENGINEERING & ENVIRONMENTAL BASED PROCESS PARAMETERS | | | | | | | |
| | Process Complexity Energy Needs Controllability Automation Reproducibility Cost Current Status/Development Needed Scale-up Potential | Process Complexity Energy Needs Controllability Automation Reproducibility Cost Environment Acceptability Safety Waste Management Toxicity & Health Hazards Corrosion Current Status/Development Needed Scale-up Potential | Process Complexity Energy Needs Controllability Automation Reproducibility Cost Environment Acceptability Safety Waste Management Toxicity & Health Hazards Corrosion Current Status/Development Needed Scale-up Potential | Process Complexity Energy Needs Controllability Automation Reproducibility Cost Environment Acceptability Safety Waste Management Toxicity & Health Hazards Corrosion Current Status/Development Needed Scale-up Potential | Process Complexity Energy Needs Controllability Automation Reproducibility Cost Environment Acceptability Safety Waste Management Current Status/Development Needed | | |

Exhibit 3.2 RABiTS Substrate Preparation Method and Pulsed Laser-Based Buffer Deposition

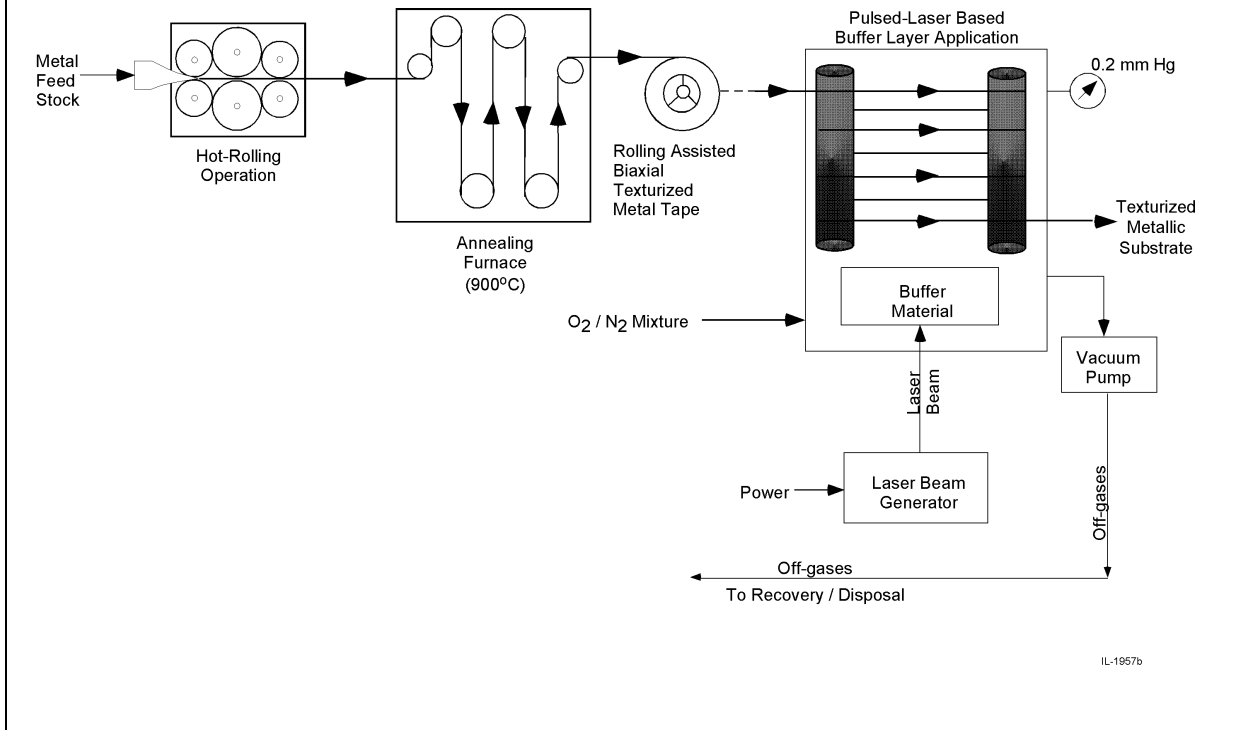
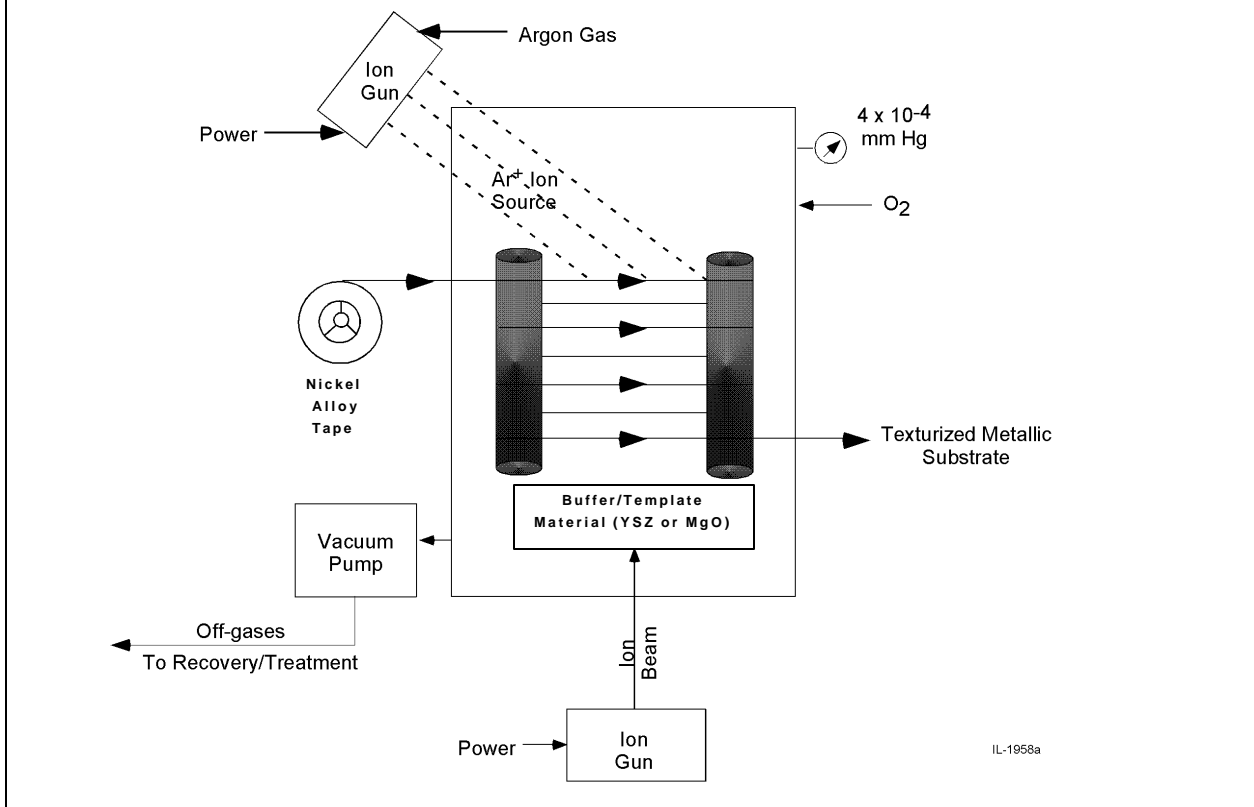
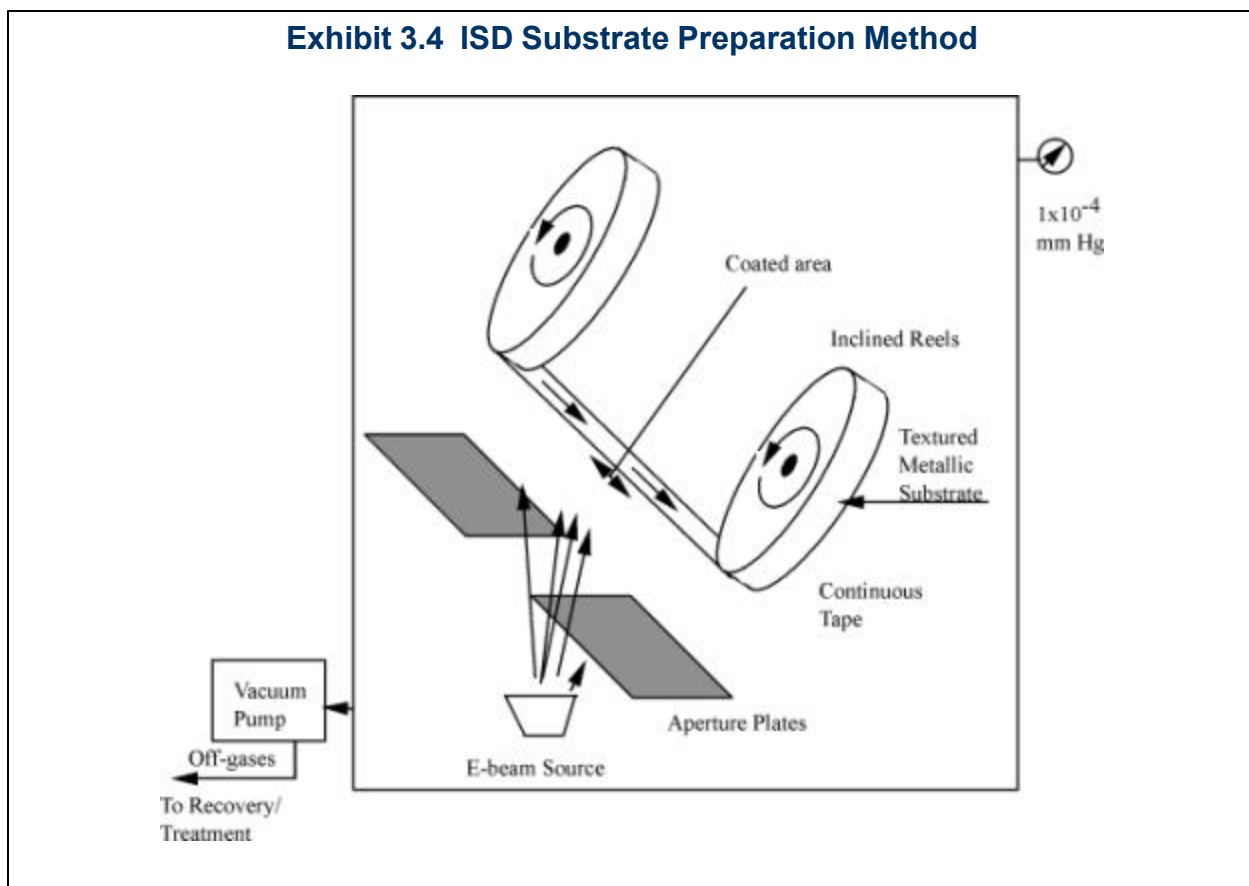

Exhibit 3.3 IBAF Substrate Preparation Method



The other option for producing textured metallic substrate is called the Ion Beam Assisted Deposition (IBAD) process and is shown in Exhibit 3.3. The IBAD process differs from the RABiTS process in that no texture is forced on the starting metal strip, but rather the first buffer layer laid on the metal strip is forced to have a preferred texture independent of the underlying metal strip. This is accomplished by using an ion beam impinging on the thin film buffer surface as it is being laid down by vapor phase deposition. Thus, in the IBAD process, the required surface texture results from the initial buffer layer deposition rather than using the metal surface as an initial growth template. Various metals could potentially be used as the substrate base metal, but a high nickel content super alloy, is the preferred choice because of its easy availability, high-temperature strength, and good thermal expansion match with the buffer and YBCO materials. The IBAD-YSZ process is a slow process and by its general nature is carried out only as a vapor phase deposition process. IBAD-MgO, in contrast is very fast due to the need for a thin IBAD layer followed by a homo-epitaxial MgO layer. Although in Exhibit 3.3, an ion beam is shown as the source for vaporizing the buffer material (YSZ), a laser powered or sputtering scheme could be considered as well. Like RABiTS, IBAD represents a family of possible options involving various buffer and base metal materials.

The third option for producing textured metallic substrates is called inclined substrate deposition (ISD) and is shown in Exhibit 3.4. Like the IBAD process, the ISD process differs from the RABiTS process in that no texture is forced on the starting metallic substrate, but rather the first buffer (seed) layer laid on the metal strip is forced to have preferred texture independent of the underlying metal substrate. This is accomplished by inclining the substrate at a prescribed angle to the plume. Various metals/alloys could potentially be used as the substrate material. The ISD process is very fast (≈ 100 A/sec). Although, in Exhibit 3.4, ISD buffer layer application is



shown being carried out using electron beam evaporator, a PLD or sputtering scheme could be considered as well.

As described above, RABiTS, IBAD and ISD all provide a textured substrate that consists of a starting metal strip with appropriate buffer material(s) laid down with a preferred orientation. This textured substrate then provides the foundation over which the HTS film is deposited using various physical and/or chemical methods.

3.2 OPTIONS FOR APPLYING HTS MATERIAL ONTO TEXTURED SUBSTRATES

The textured substrate obtained from the RABiTS, the IBAD or the ISD processes provides a starting material over which the epitaxial layer of YBCO (HTS) can be applied using various candidate options. The process schematics for such YBCO deposition options are shown in Exhibits 3.5-3.13, and brief descriptions for each of these flow sheets are as follows.

Pulsed Laser Deposition/Ablation (PLD/PLA). A process schematic incorporating pulsed laser-based YBCO deposition is shown in Exhibit 3.5. The primary characteristic of this process is that YBCO targets, which have been processed off-line by a variety of possible methods, are vaporized or ablated by a laser source. The vaporized YBCO is deposited as a film on the substrate at about 800°C in a low pressure atmosphere containing an O₂-N₂ mixture. PLD is effectively a transfer of YBCO from a target source to the substrate surface.

E-Beam Based Deposition. A process schematic for YBCO deposition by the E-beam technique is shown in Exhibit 3.6. The features of E-beam deposition of YBCO are that the E-beam vaporizes elemental Y, Ba (or BaF₂ for the ex-situ process) and Cu which are deposited in oxide form at very low pressures (~10⁻⁵ mm Hg), at 740°C under an atomic oxygen atmosphere. The E-beam technique synthesizes YBCO on the substrate from its constituent elements or in the case of the ex-situ approach, enables deposition of YBCO precursor. The ex-situ process is thought to be very slow (1A/sec conversion rate) but is done in a relatively inexpensive and non-vacuum furnace. The in-situ process is unproven for tapes although it has been used for wafers. This process does not require the costly and time consuming post water heat treatment to remove fluorine.

Metal Organic Chemical Vapor Deposition (MOCVD). In the MOCVD scheme depicted in Exhibit 3.7, the Y, Ba and Cu are introduced as vaporized forms of highly pure organic precursors. It is anticipated that a mixture of Y(TMHD)₃, Ba(TMHD)₂ and Cu(TMHD)₂ (where TMHD stands for 2,2,6,6-tetramethyl-3-5 heptanedionate) would be prepared in an organic solvent mix that consists of tetrahydrofuran (THF), isopropanol and tetraglyme. The product mix is believed to be very sensitive to trace levels of contaminants and is correspondingly costly for high purity. Application of the precursor is carried out in a MOCVD chamber maintained at about 600-850°C and at a pressure of 1-10 mm Hg. The required N₂O/O₂ plasma is introduced from a plasma generator tube and vaporized Y-, Ba-, and Cu- containing precursors are conveyed by flowing N₂ at about 230°C to the deposition chamber.

Sol-Gel. The sol-gel method is a solution growth technique and is devoid of energetic particles for transport or vaporization of precursor material but rather uses a conventional dip coating of a precursor bearing liquid which is subsequently dried and reacted. A process schematic for the

Exhibit 3.5 Pulsed Laser Deposition

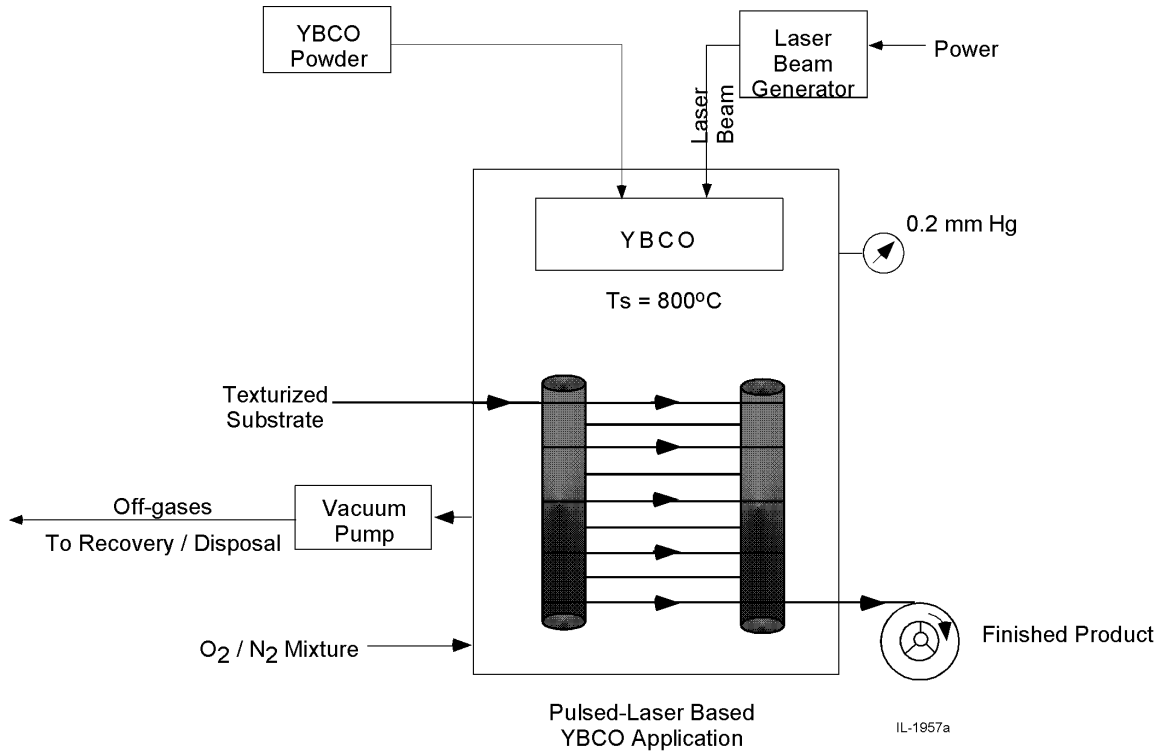

Exhibit 3.6 E-Beam Based Deposition

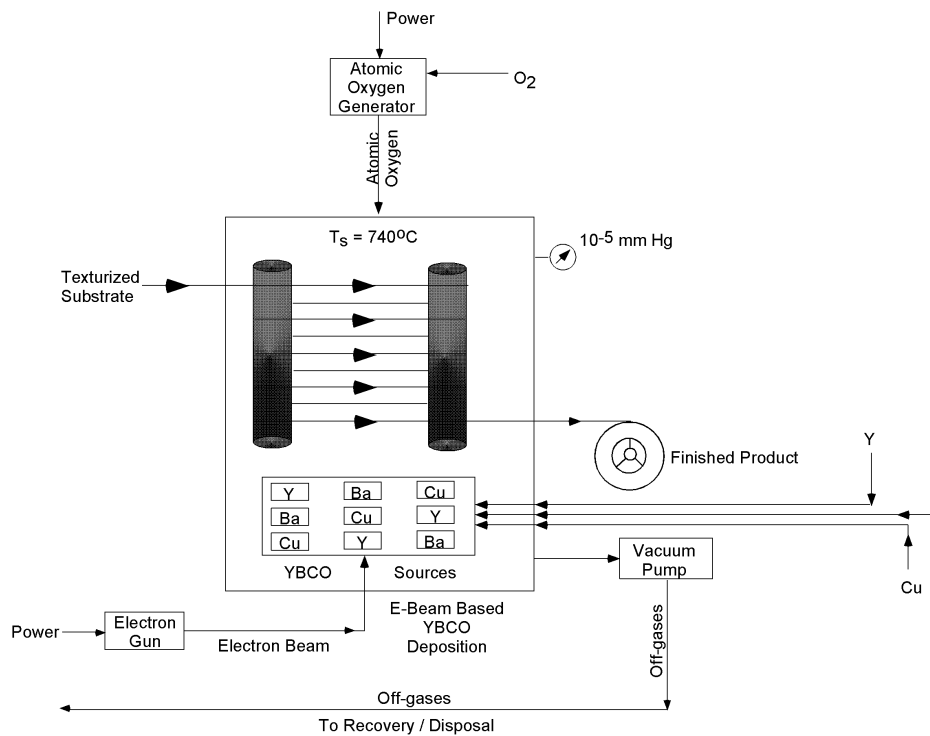

Exhibit 3.7 MOCVD Method

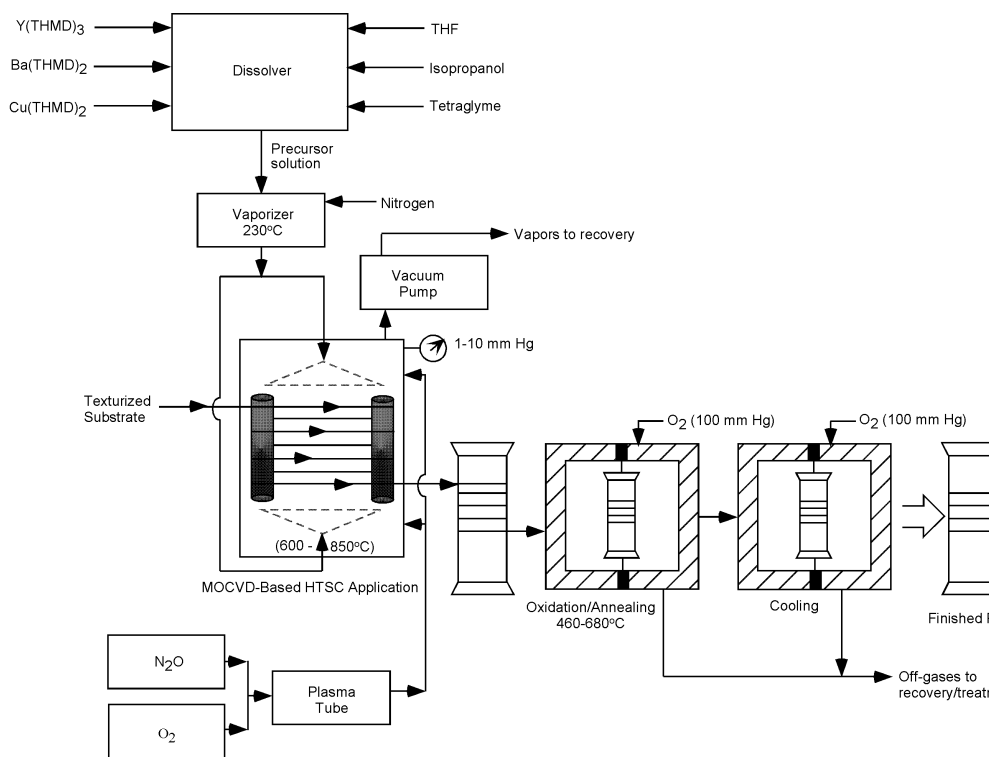
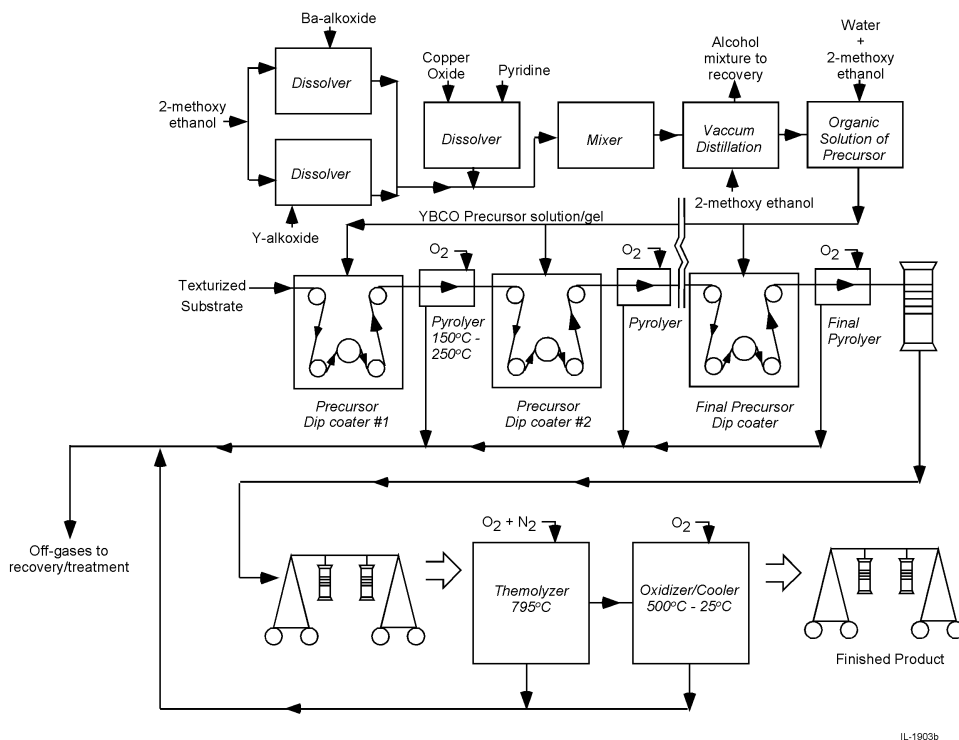

Exhibit 3.8 Sol-Gel Method



sol-gel technique is shown in Exhibit 3.8. A gel solution containing precursors is prepared by mixing organic solutions of Ba-alkoxide and Y-alkoxide in 2-methoxy ethanol, with a solution of copper oxide in pyridine. Vacuum distillation and partial hydrolysis are used to convert the organic solution to a gel solution of desired concentration and flow characteristics for dip coating. It is believed that repetitive dip coating processes with the gel will be required to produce film of uniform crystalline structure and desired overall thickness. Between successive coatings, the deposited gel containing the precursors is pyrolyzed in an oxygen atmosphere at 150-250°C to vaporize organic solvent and to oxidize the precursors.

Chemical Vapor Deposition (CVD). This particular chemical coating option uses commonly available halide salt precursors: Y (from YCl_3), Ba (from BaI_2), and Cu (from $CuCl$) and the process is depicted in Exhibit 3.9. The precursor salts are thermally vaporized and conveyed in stoichiometric proportions to a common mixing point by flowing N_2 . Coating of the textured substrate by the vapor mixture is carried out in a chamber maintained at 750-950°C, and 20 mm Hg pressure under a moist O_2 atmosphere.

Aerosol/Spray Pyrolysis. Another chemical coating technique that uses commercially available salt precursors is the aerosol/spray pyrolysis technique which is shown in Exhibit 3.10. Aqueous solutions of Y (NO_3)₃, Ba (NO_3)₂ and Cu (NO_3)₂ in stoichiometric amounts are prepared from high purity nitrates and water. The textured substrate is coated with the atomized precursor solution in a spray chamber where the substrate speed, chamber temperature and O_2 partial pressure are process variables of importance. Like the dip coating step in the sol-gel process described above, it may be necessary to use a multiplicity of spraying operations to acquire the desired YBCO film thickness and epitaxy.

Metal Organic Decomposition (MOD). The MOD process, depicted in Exhibit 3.11 is similar to the aerosol spray pyrolysis described above. In the MOD process, stoichiometric proportions of Ba, Y and Cu acetates are mixed in aqueous trifluoroacetic acid. The resulting mixture is dried and re-dissolved in methanol to form an organic solution of trifluoroacetates which is used to dip coat a textured substrate. The coated tape is oven heated at about 200-400°C under O_2 atmosphere to remove water of crystallization and excess organic solvent and to convert the trifluoroacetate film to oxyfluoride form. Repetition of the coating and baking operations may be required to achieve the desired film thickness.

Electrodeposition. This is an electrochemical method whereby dissolved material in an ionized form is uniformly deposited over the substrate maintained at the appropriate polarity. In the literature, no information was found related to suitable buffer coating over a metal substrate, however, it is assumed here that this technique would work on any suitably textured substrate. An electrodeposition process schematic is shown in Exhibit 3.12. The precursor solution is prepared by mixing stoichiometric quantities of $Ba(NO_3)_2$, $Cu(NO_3)_2 \cdot 2.5 H_2O$, and $Y(NO_3)_3 \cdot 6 H_2O$ in deionized water (acidified with dilute HNO_3 solution) and then by further diluting with isopropanol to provide the desired nitrate concentration. The textured substrate is coated with the precursor material in an electrolytic cell and subsequently dried at about 150°C to remove adsorbed water and convert some metal hydroxides to appropriate oxide form. They are then subjected to high-temperature treatment to complete the YBCO conversion

Exhibit 3.9 CVD Method

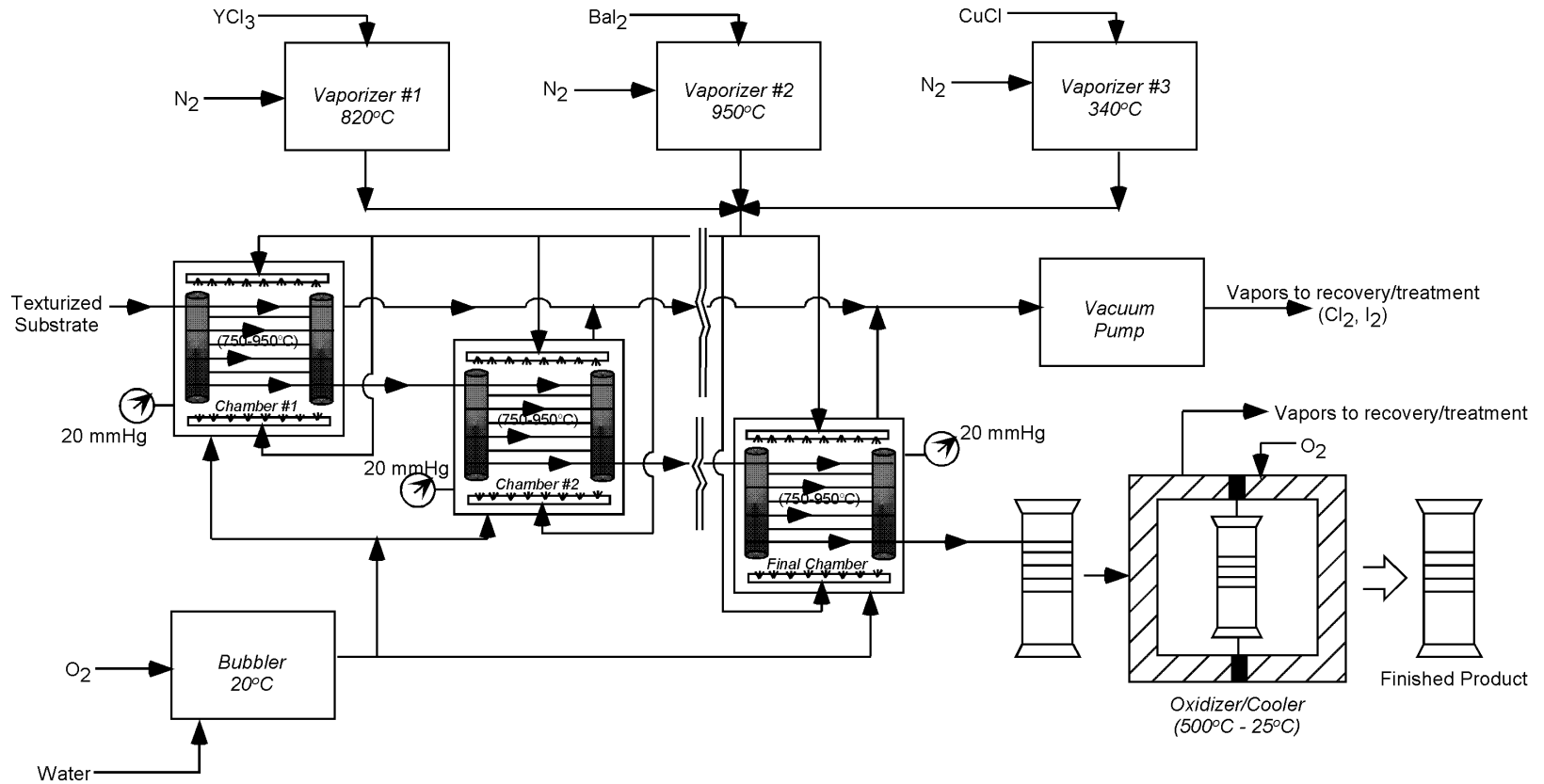

IL-1904s

Exhibit 3.10 Aerosol/Spray Pyrolysis Method

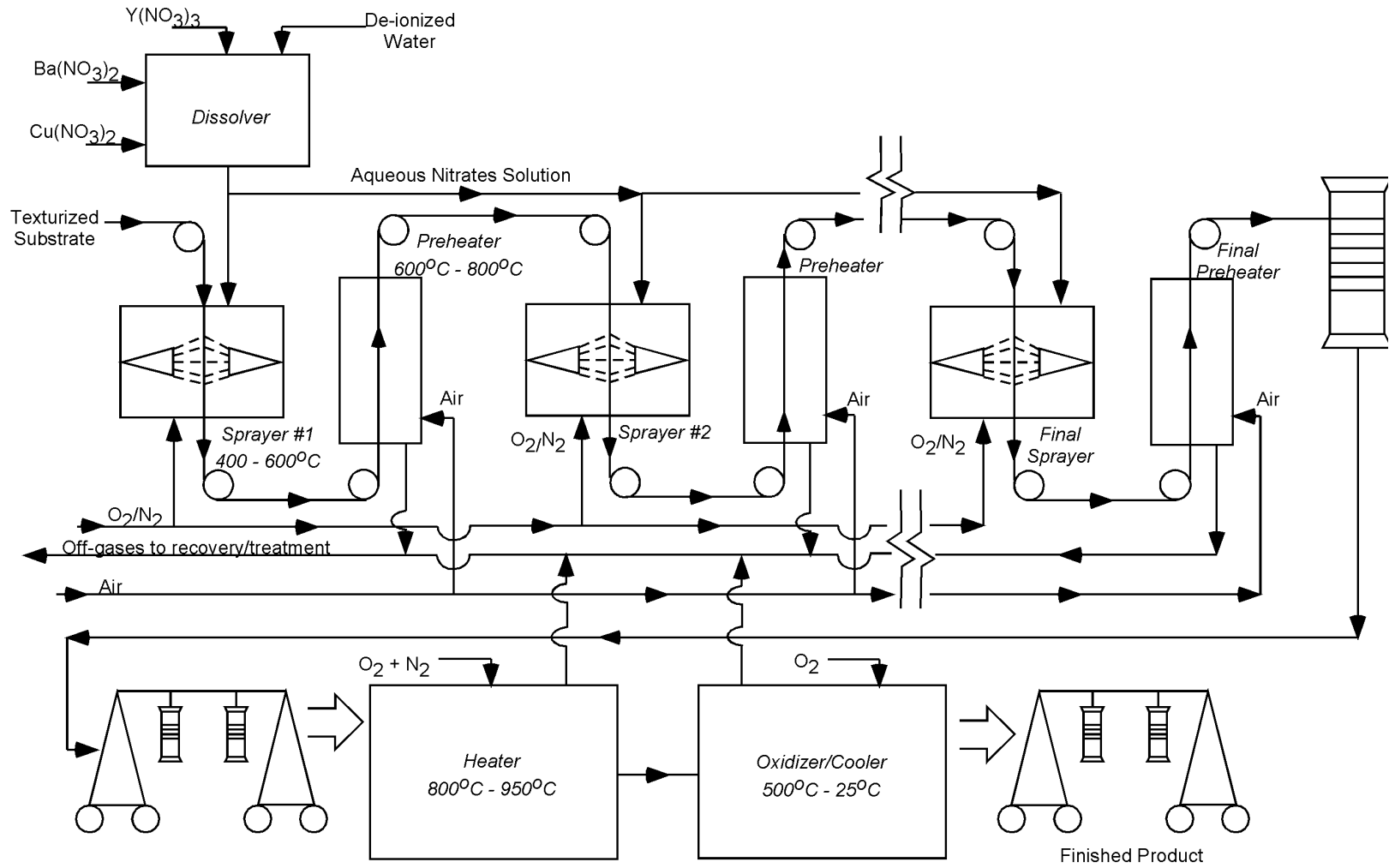

IL-1900s

Exhibit 3.11 MOD Method

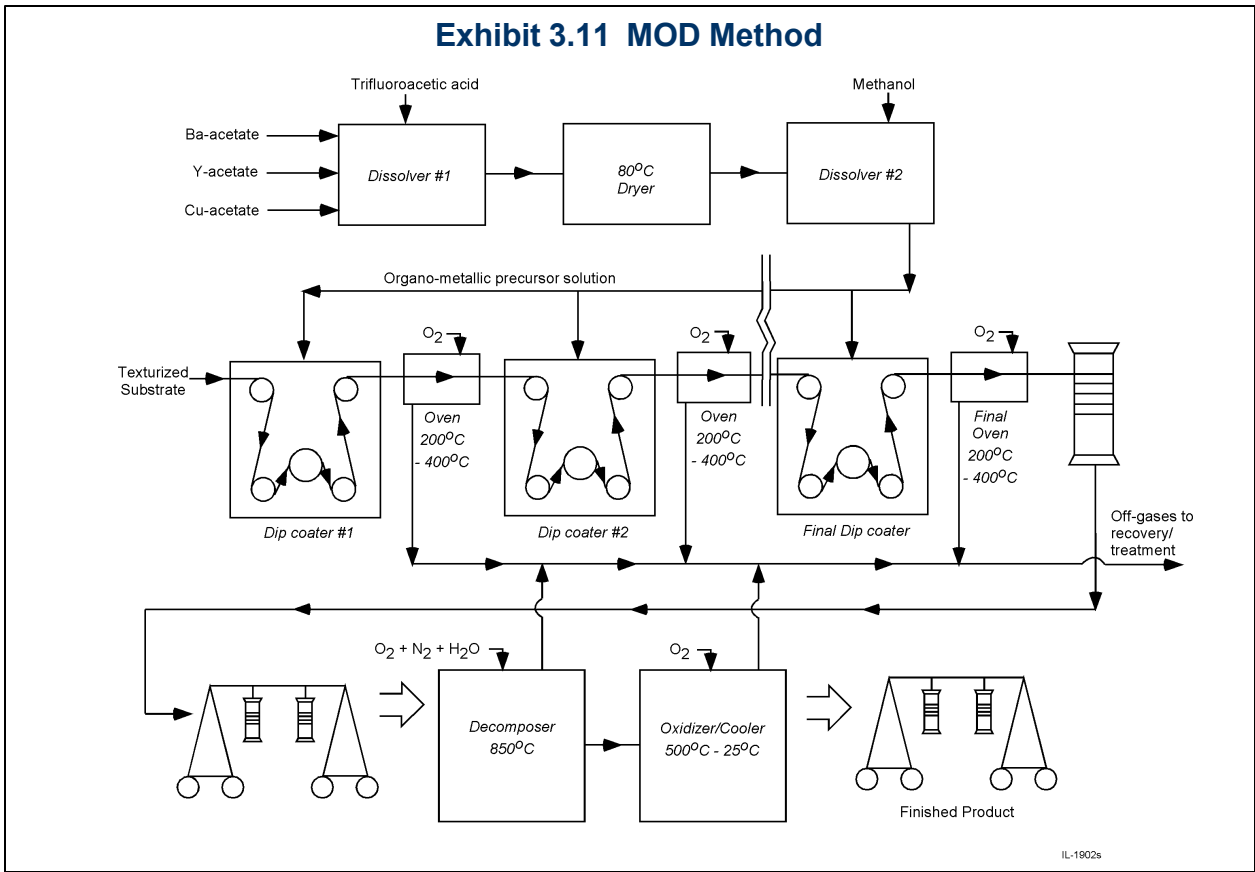
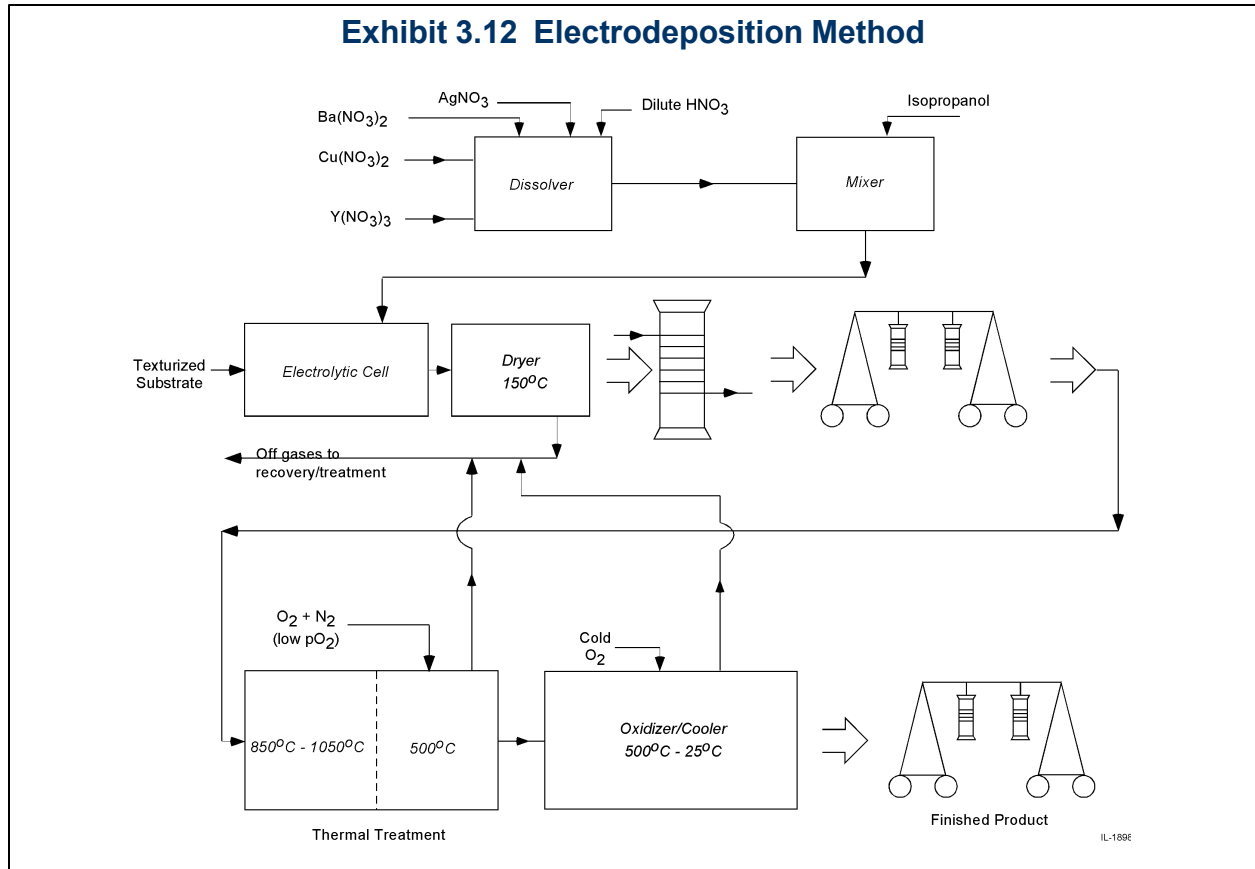

Exhibit 3.12 Electrodeposition Method



Electrophoresis. Electrophoresis is the only candidate coating option discussed herein that has been used to produce kilometer lengths of conductor at rates up to 1 m/min. This work was done on silver tapes and yielded low J_c YBCO. An improved version utilizing a textured substrate is proposed in the process schematic presented in Exhibit 3.13. The process uses finely ground YBCO in a non-aqueous liquid which is transferred to the substrate in an electrophoretic cell. The coated substrate is then sintered in a furnace maintained at 950-1030°C under O_2/N_2 (low pO_2 atmosphere) and with a residence time of about 1-30 min to ensure complete oxidation.

Of the nine processes described above, PLD/PLA, E-beam based deposition and electrophoresis are physical deposition processes and the others are chemical deposition methods. In addition, PLD/PLA and E-beam based depositions are the only processes that result in a thin film of YBCO in the substrate and require no additional post coating thermal treatment. The other processes, MOCVD, sol-gel, CVD, aerosol/spray pyrolysis, MOD, electrodeposition and electrophoresis all required post coating thermal treatment to complete the annealing and oxidation of the deposited film to the desired YBCO phase. At the various steps within each of the processes described waste streams of material are generated as results of decomposition of precursor materials and inefficiencies of the coating processes. In some cases, as in case of the halide salts used in chemical vapor deposition, the waste streams can be highly corrosive and environmentally unfriendly.

Finally, the end step in all nine processes would be a common final step comprised of a passivation/stabilization/insulation layer to provide the final finished conductor product in a usable form.

Exhibit 3.13 Electrophoresis Method

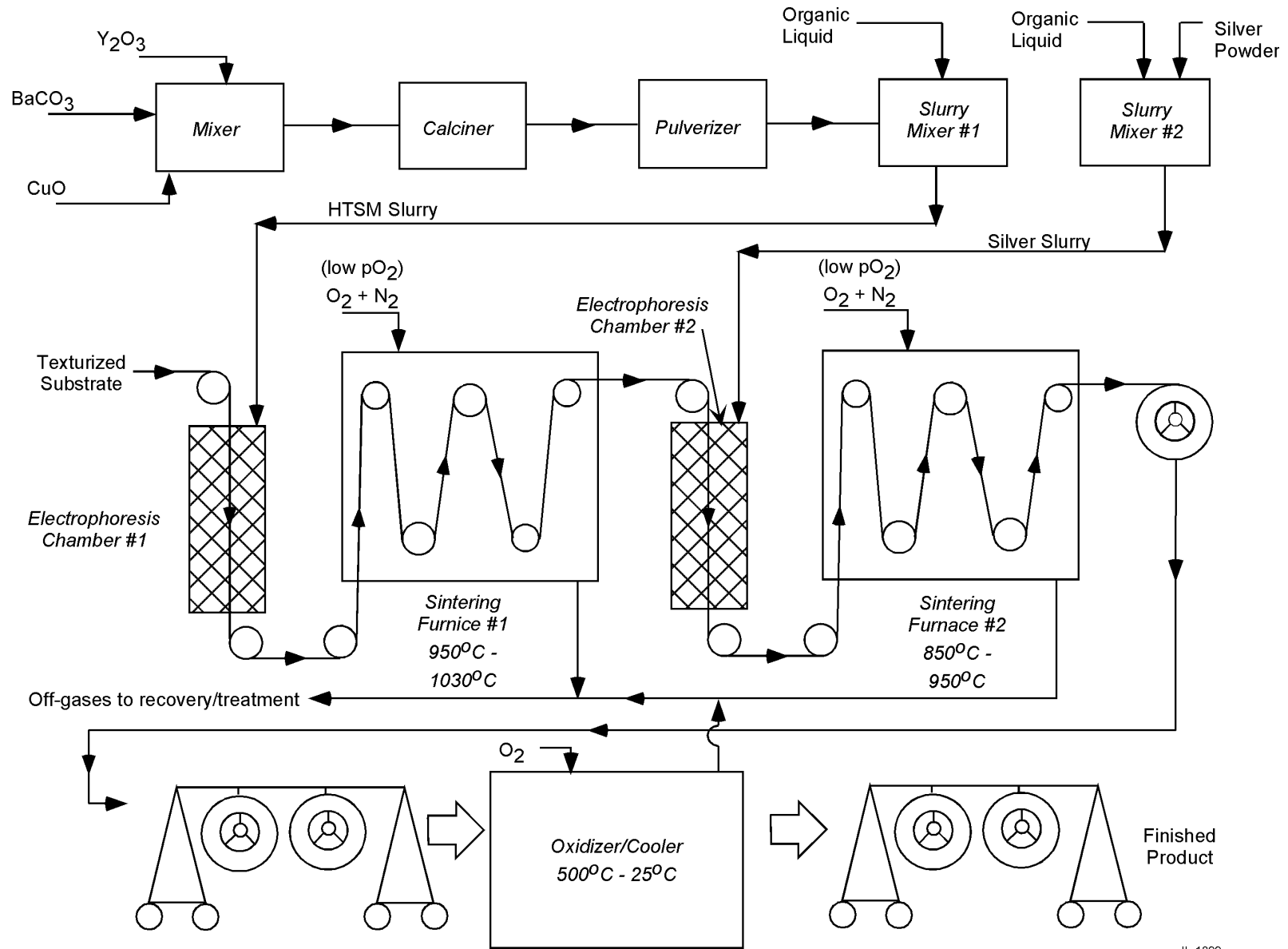

IL-1899

4.0 Process-Related Technical Issues

The material in this section is reproduced and modified from portions of the following report: “Evaluation of Methods for Application of Epitaxial Buffer and Superconductor Layers,” Topical Report, UTSI 97-02, DOE/PC/95231-11, March 1999.

The major issues for the economical manufacturing of long-length YBCO-coated conductors pertain to the capability of uniform, epitaxial deposition at high rates over a large area with a continuous process. Of course such capability has to meet the other important requirements of proper stoichiometric composition and epitaxial crystalline structure.

For each of the processing options discussed in Section 3, various technical issues fall into the following generic areas where additional R&D work is needed.

- *Cost of chemicals*—There is a need to find cheaper salts or develop alternative but simple ways of making them.
- *Mass transfer and reaction kinetics data*—To design a deposition chamber, pyrolyzer or thermal treatment (oxidizer, cooler, etc.) rates at which the chemical transformations are taking place and/or the species are being transported across the phase boundaries need to be known. Appropriate mathematical models need to be developed from the laboratory scale experience so that the data/results can be scaled-up to larger/commercial scale systems.
- *Diagnostics and control*—The requirement of high J_c performance necessitates very sophisticated and quick response type diagnostics and control system. On-line control systems to meet such needs are either not sufficiently developed or do not exist. Experiences from related commercial operations can be useful, but the needs may be quite different; and therefore, parameters of importance and ways and means to monitor them on-line may involve significant efforts.
- *Environmental issues*—Even though the quantities of chemicals used and water products (liquids and gases) produced will be small in comparison to other manufacturing industries, with the ever increasing demands on environmental acceptability and compliance, the major waste products from the system will need to be identified, characterized and then appropriate recovery/treatment/disposal options will need to be developed.
- *Outer passivation/stabilization/insulation layer*—With YBCO being chemically sensitive to moisture and air, an effort needs to be started to identify suitable candidates for this protective layer as well as the appropriate method to apply them over the coated conductor wires/tapes. A suitable amount of silver will be required for some applications in order to provide electrical stability in the event of a fault.
- *Splice connections*—It seems that in commercial manufacturing of long-length coated conductors, a need may exist to connect sections of the good/acceptable wires to make a long wire of desired length for economic reasons. To maintain continuity in

the superconducting properties at such connections, suitable materials as well as appropriate techniques to incorporate them will be needed.

- *Overall cost of production*—Because all the sequential steps in the processing of a coated conductor wire are not carried out yet, the estimated cost of production needs to include adequate details or justifications for the various cost parameters that are involved in its development. An unbiased effort needs to be made with help from industrial partners to develop the cost of the finished product using available information and standard estimating procedures. This effort will either validate the desired target or it will identify the areas where the costs need to be reduced.

5.0 Priority R&D Activities

A number of R&D activities were identified to facilitate the achievement of the vision. For each technology development area (see Exhibit 1.4), Exhibits 5.1-5.9 present R&D needs, activities, year 2005 performance targets, and industry needs in 2010.

The technology development areas include:

- **Fabrication Pathways**
- **Substrate Development and Characterization**
- **Simplified Buffer Layer Architecture**
- **Improved YBCO Quality**
- **Faster Deposition Rates**
- **Process Monitoring and Control Strategies/Methods**
- **Production Scale-Up (Industry-Led)**
- **End-User Applications (Industry-Led).**

The following materials-related R&D activities received the highest priority:

Microstructure Evolution

- Investigate microstructure evolution during various types of processing, including electron microscopy and theoretical modeling. (2003)
 - Nucleation and growth, buffer-123; precursor-123/buffer reactions
 - Understand and improve deposition rate, microstructure, and performance relationships
 - Need more TEM studies that relate microstructure to processing variables: temperature, deposition rate, thickness, etc. to performance
- Determine processing parameter space for 123 (e.g. temperature, PO₂, time) (2003)
- Determine the formation and growth dynamics of YBCO layers considering the phase diagram (2004)
- Develop detailed understanding of J_c versus thickness dependence (2003)

Grain Boundaries

- Conduct research on the chemistry and physics of grain boundaries and how that relates to current carrying capacity (2005)
 - Develop doping process to increase J_c across grain boundaries
- Develop methods to reduce grain boundary misorientation (2005)

Flux Pinning

- Conduct continuing research on various types of process-specific microstructures and their effects on flux dynamics and current flow (2005)

Substrates

- Develop technique for optimizing thermo-mechanical processes for texturing metals (2002)
 - Reduce substrate surface roughness, improve texture quality, and reduce grain boundary grooving
- Continue efforts to improve the development of nickel alloy which is stronger, thinner, has better texture, lower hysteresis, and is non-magnetic (2002)
- Develop smooth, low cost hastelloy platform for IBAD and ISD templates (2002)
- Determine the dependence of the final metal substrate texture on starting microstructure and chemistry (2003)

Buffers

- Develop ISD, MgO/YSZ or other metal oxide template layers for fast production of YBCO tapes (2003)
- Conduct basic research on IBAD MgO process (2005)
- Conduct epitaxial studies of buffer/substrate, 123/buffer (2005)
- Conduct research on substrate/IBAD, MgO/buffer layer/YBCO stack interactions (2005)
- Conduct research on substrate/ISD MgO or YSZ/buffer layer/YBCO stack interactions (2004).

Deposition Techniques

- Develop alternative deposition methods for low cost, long lengths e.g. MOCVD, CCVD, Non-vacuum processing for buffer and YBCO coated conductor (2007)
 - Develop non-vacuum processing for buffer layers, YBCO coated conductors
- Develop method(s) for increase YBCO production rates, increase area (2005)
- Develop faster and more reproducible methods for fabricating both templates and YBCO films (2003)
- Conduct endurance tests of deposition techniques (2003)

Equipment

- Develop high power, low cost pulsed lasers (2004)
- Develop instrumentation for R&D and scale up (2003)
- Develop improved continuous testing techniques (2005)

The following conductor manufacturing-related R&D activities received the highest priority:

- Production Scale-Up: Low-cost fabrication of 1 km conductor with high J_e ,
- Substrate Development: Long-lengths of coated conductors with non-magnetic substrates
 - Demonstrating textured IBAD and ISD substrate fabrication in long lengths
 - Performing basic R&D of texture mechanisms and kinetics
 - Developing well textured and smooth surfaced tapes.

Within these areas, the following key task/pathways were identified:

- Increase understanding of and developing improved rolling technology and techniques/tools to produce consistent long lengths for RABiTS
- Demonstrating and improving reel-to-reel IBAD operation
- Optimizing texture in non magnetic nickel alloy (or others)
- Developing improved buffer layers
- Developing new technique to reduce surface defects.
- Process monitoring and control
- Joining and repair
- Alternative Production: Multilayer R&D to get around weak links
- Fabricate application-specific prototypes
- Establish standards for characterization

Exhibit 5.1 Alternate Fabrication Approaches

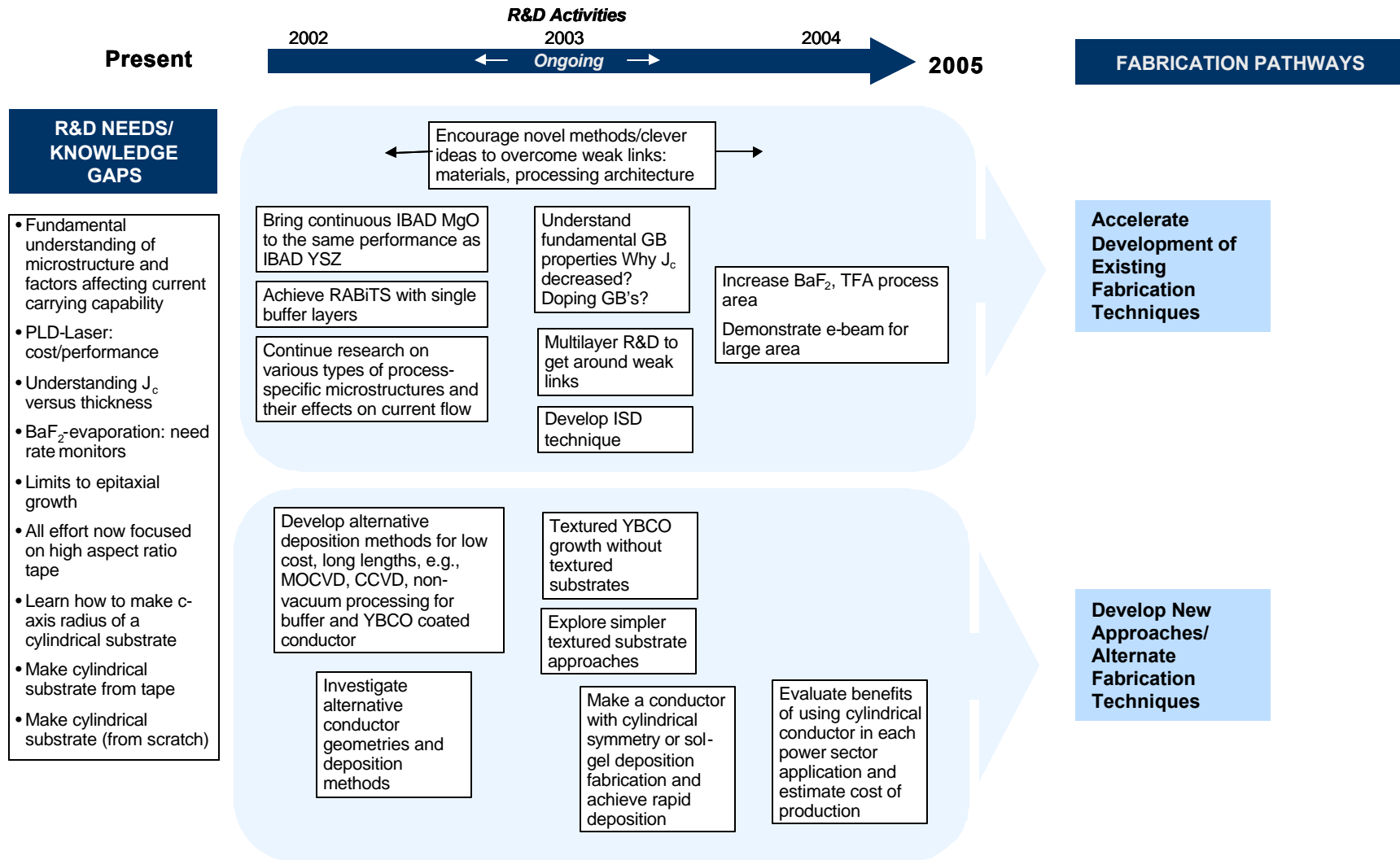

Exhibit 5.2 Substrate Development and Characterization

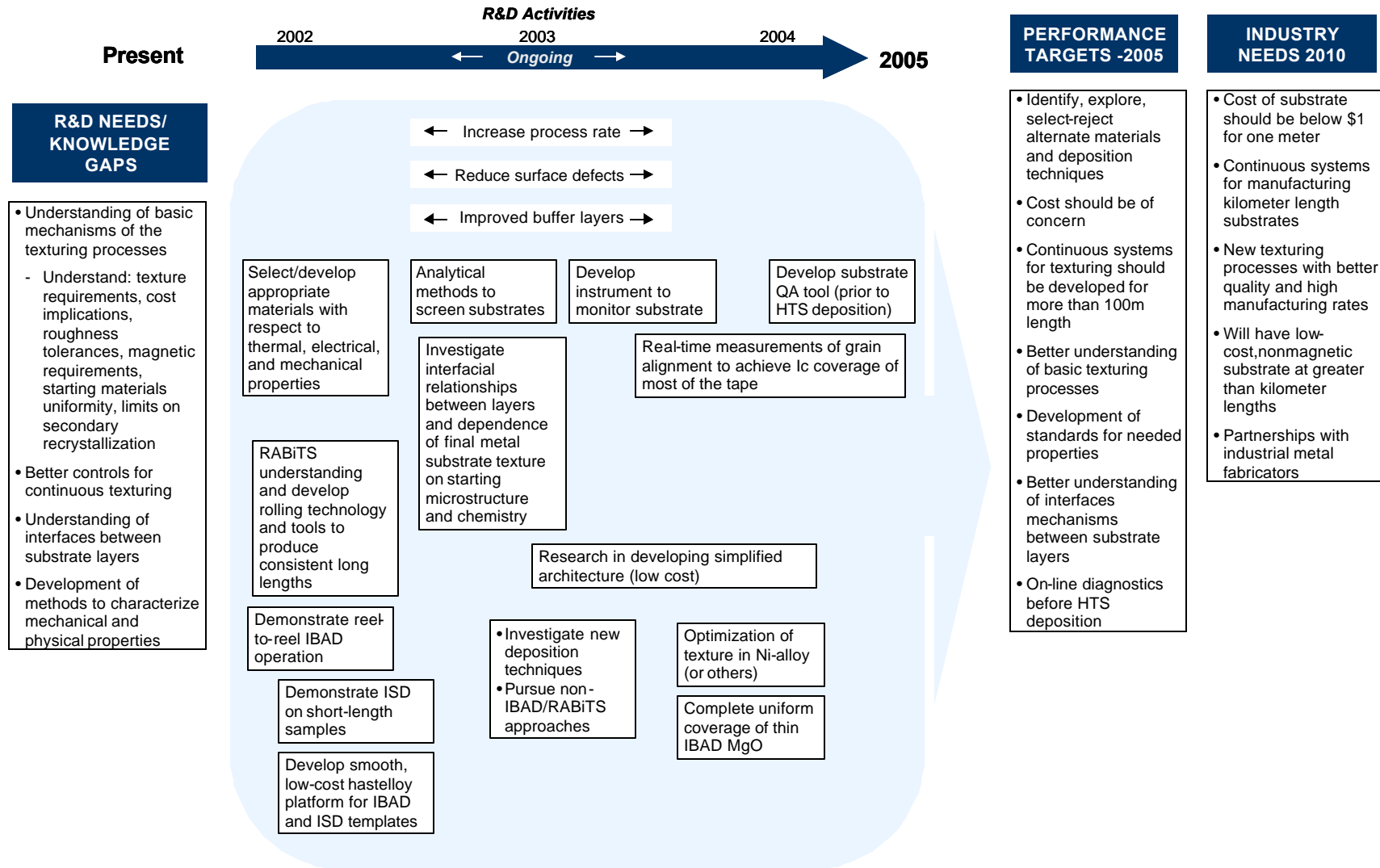
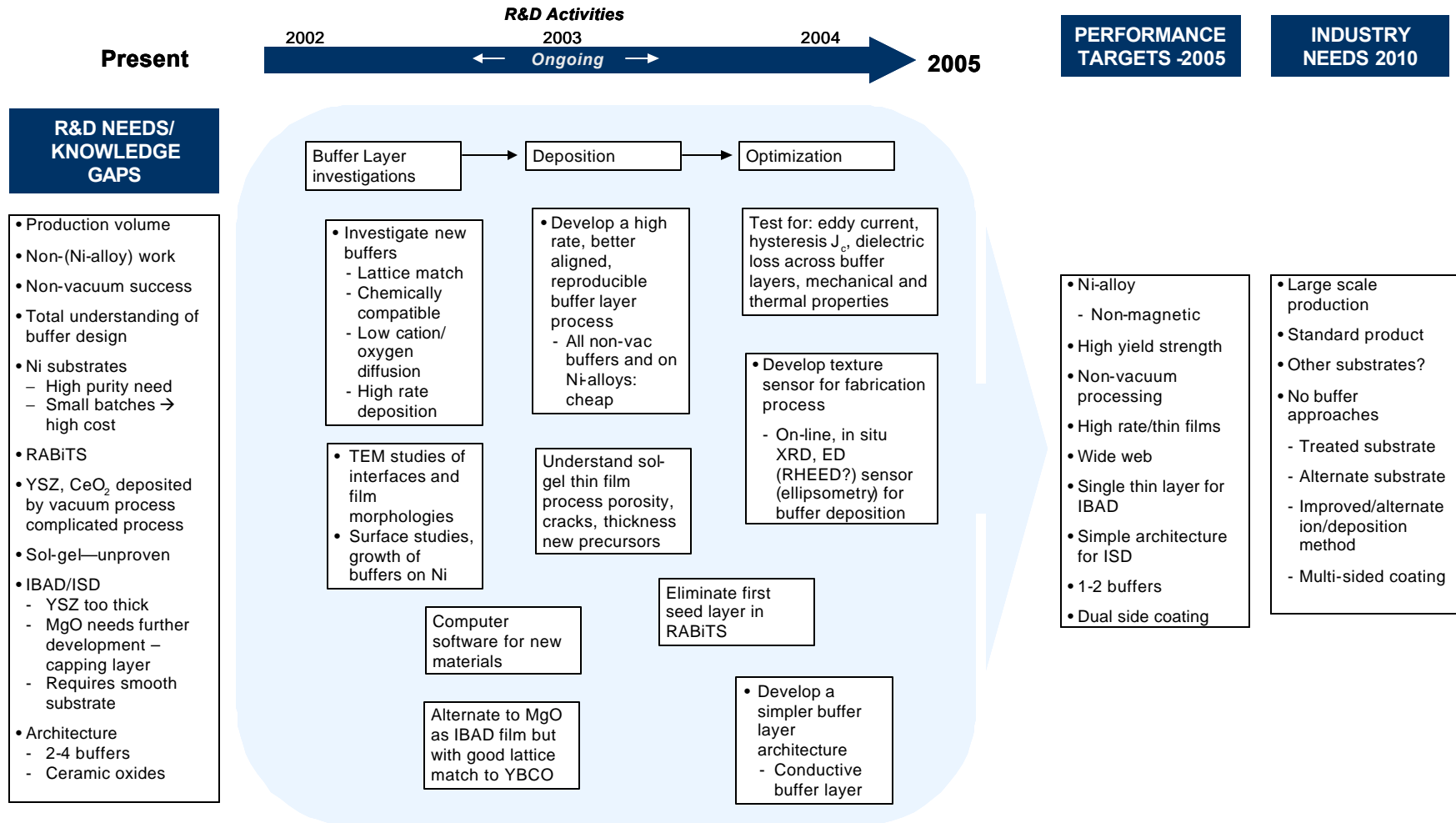

Exhibit 5.3 Simplified Buffer Layer Architecture



R&D NEEDS/ KNOWLEDGE GAPS

- Production volume
- Non-(Ni-alloy) work
- Non-vacuum success
- Total understanding of buffer design
- Ni substrates
 - High purity need
 - Small batches → high cost
- RABiTS
- YSZ, CeO₂ deposited by vacuum process complicated process
- Sol-gel—unproven
- IBAD/ISD
 - YSZ too thick
 - MgO needs further development – capping layer
 - Requires smooth substrate
- Architecture
 - 2-4 buffers
 - Ceramic oxides

Exhibit 5.4 Improved YBCO Quality

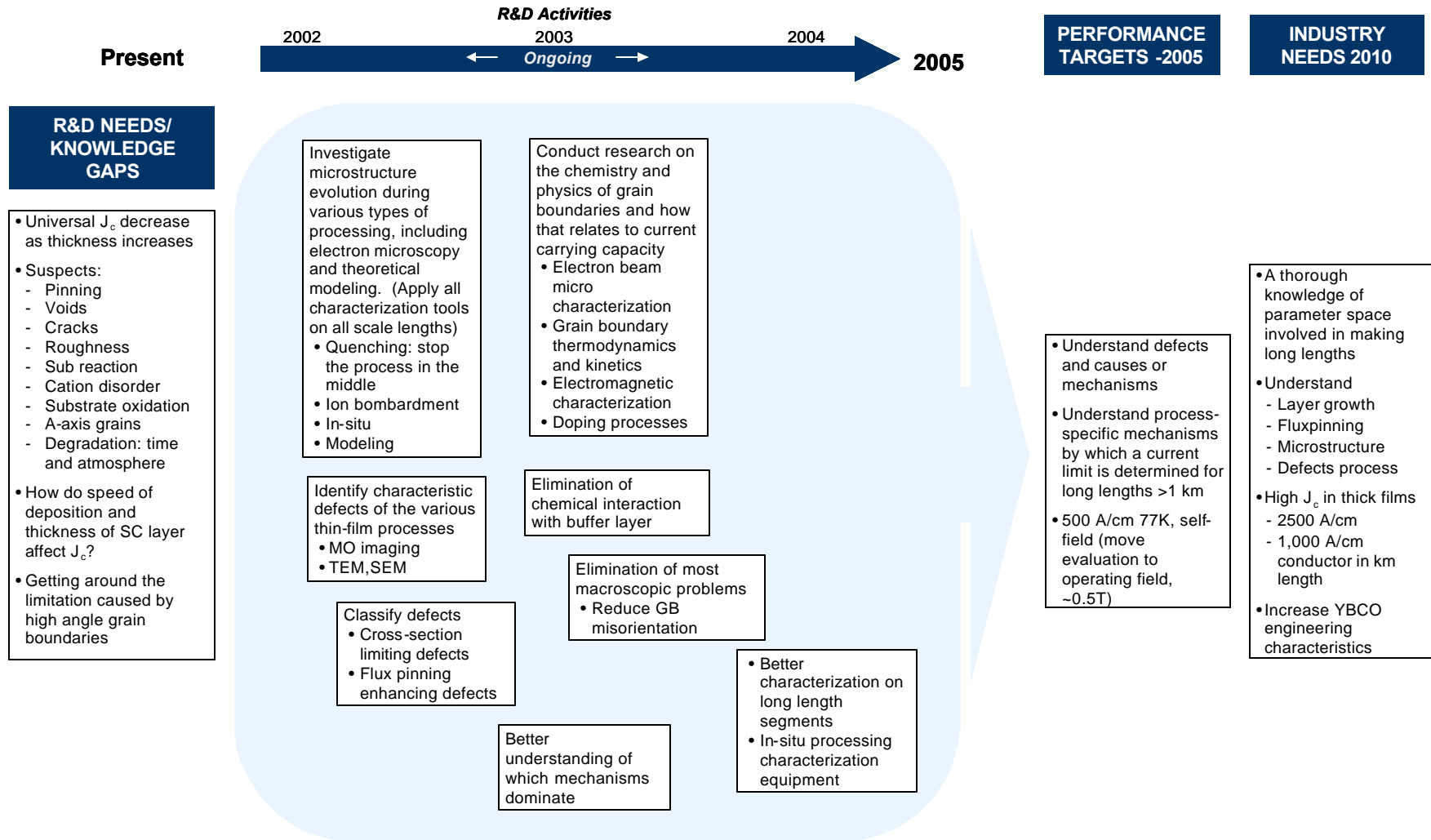

Exhibit 5.5 Faster Deposition Rates

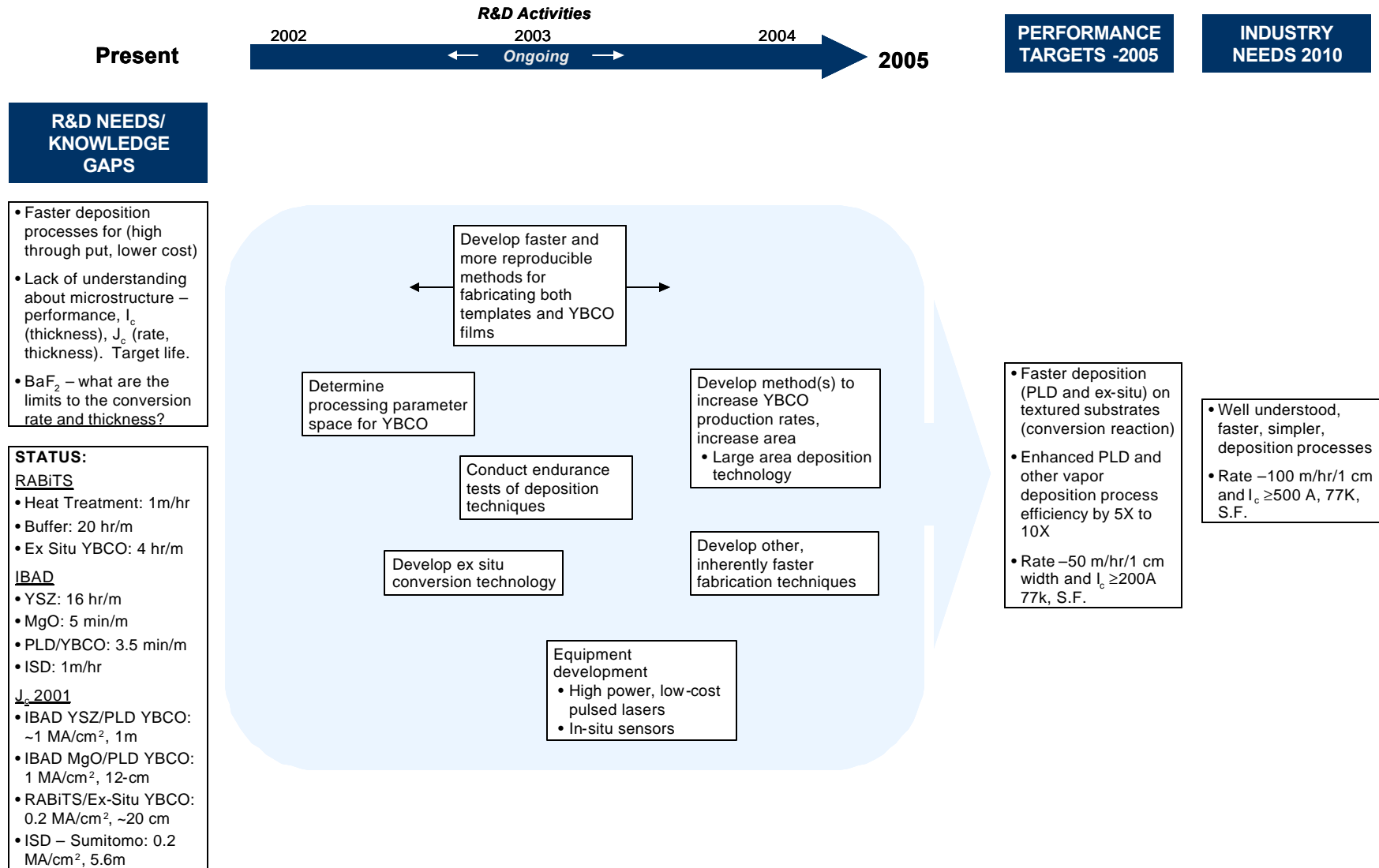

Exhibit 5.6 Process Monitoring & Control Strategies/Methods

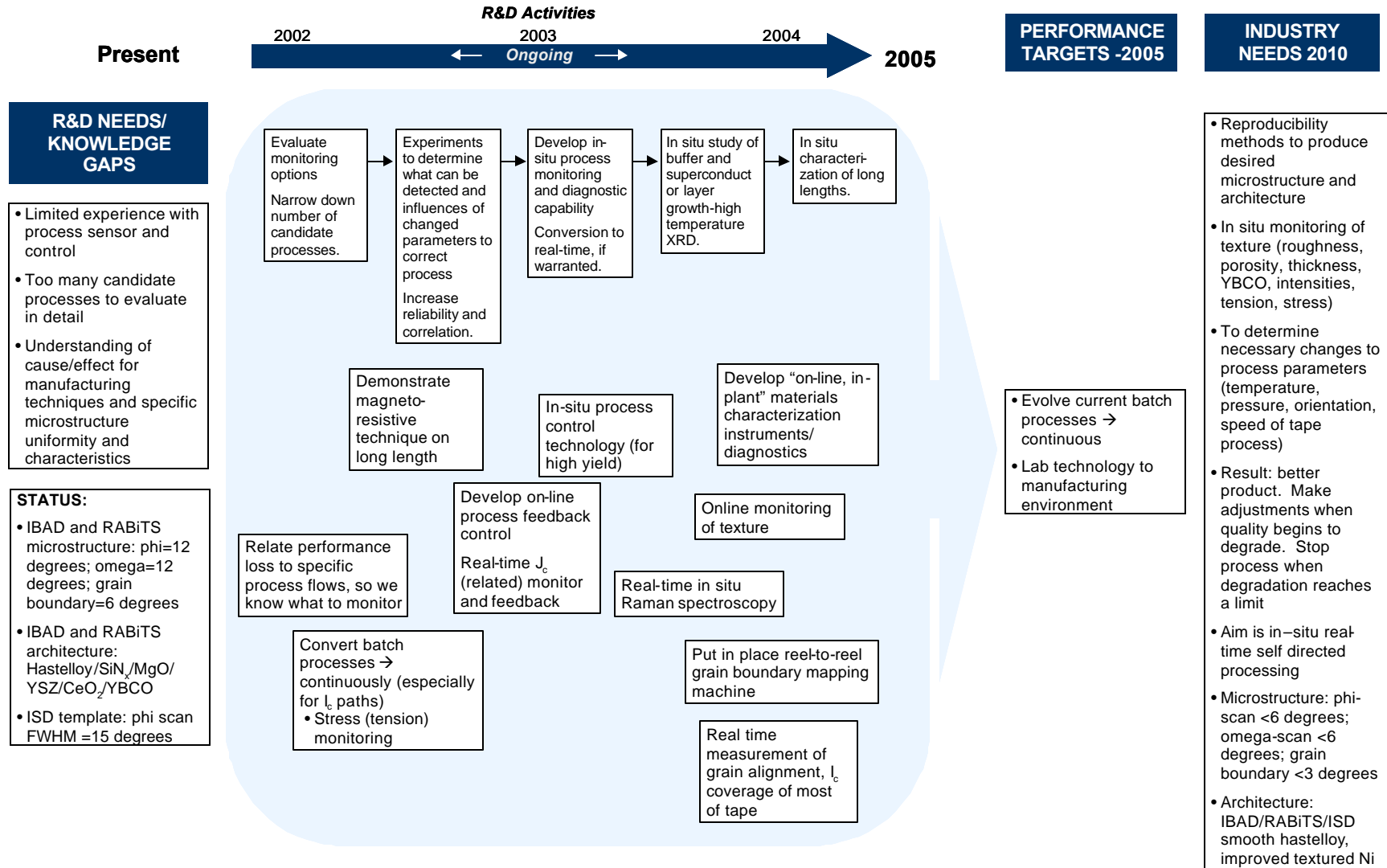

Exhibit 5.7 Conductor Characterization

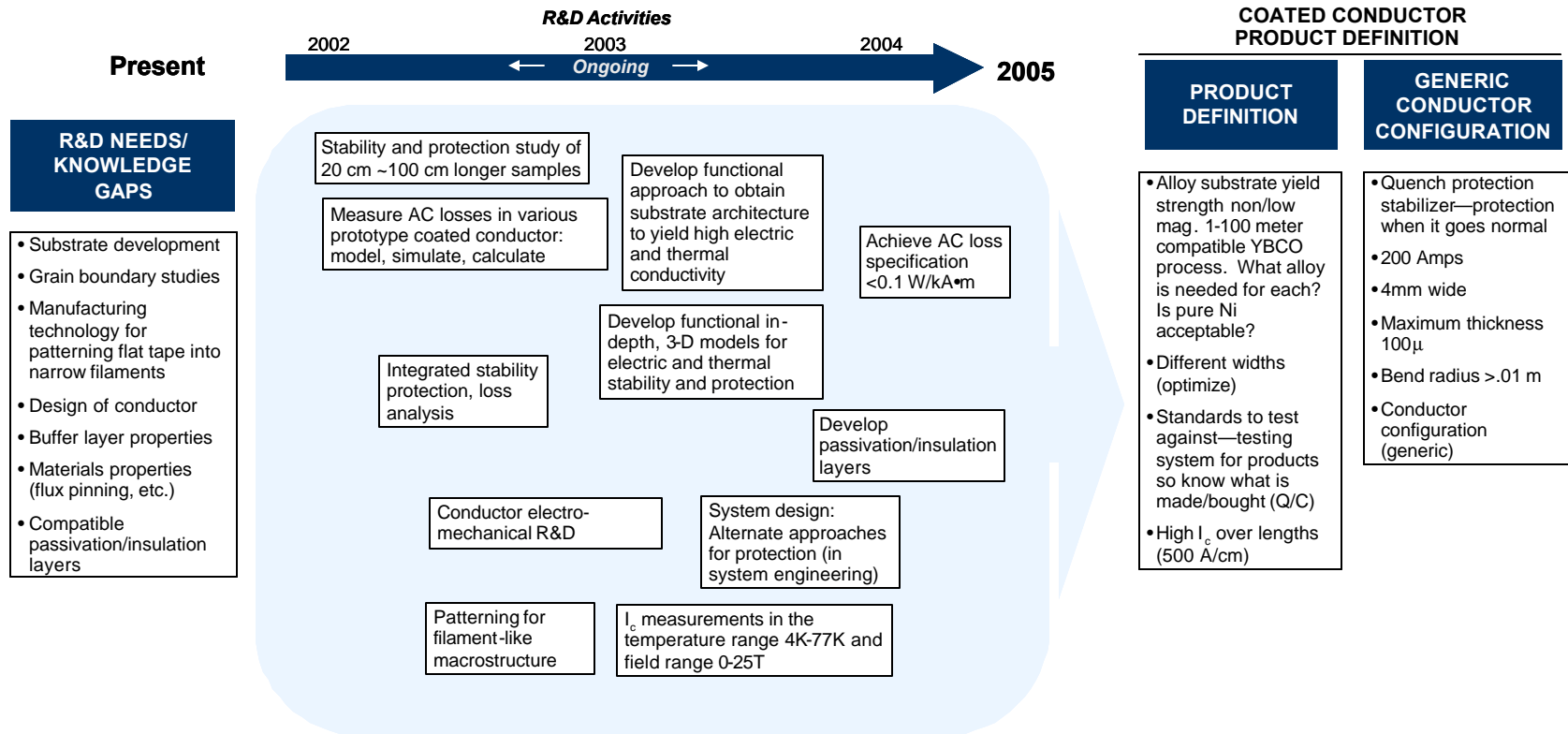

Exhibit 5.8 Production Scale-Up (Industry-Led)

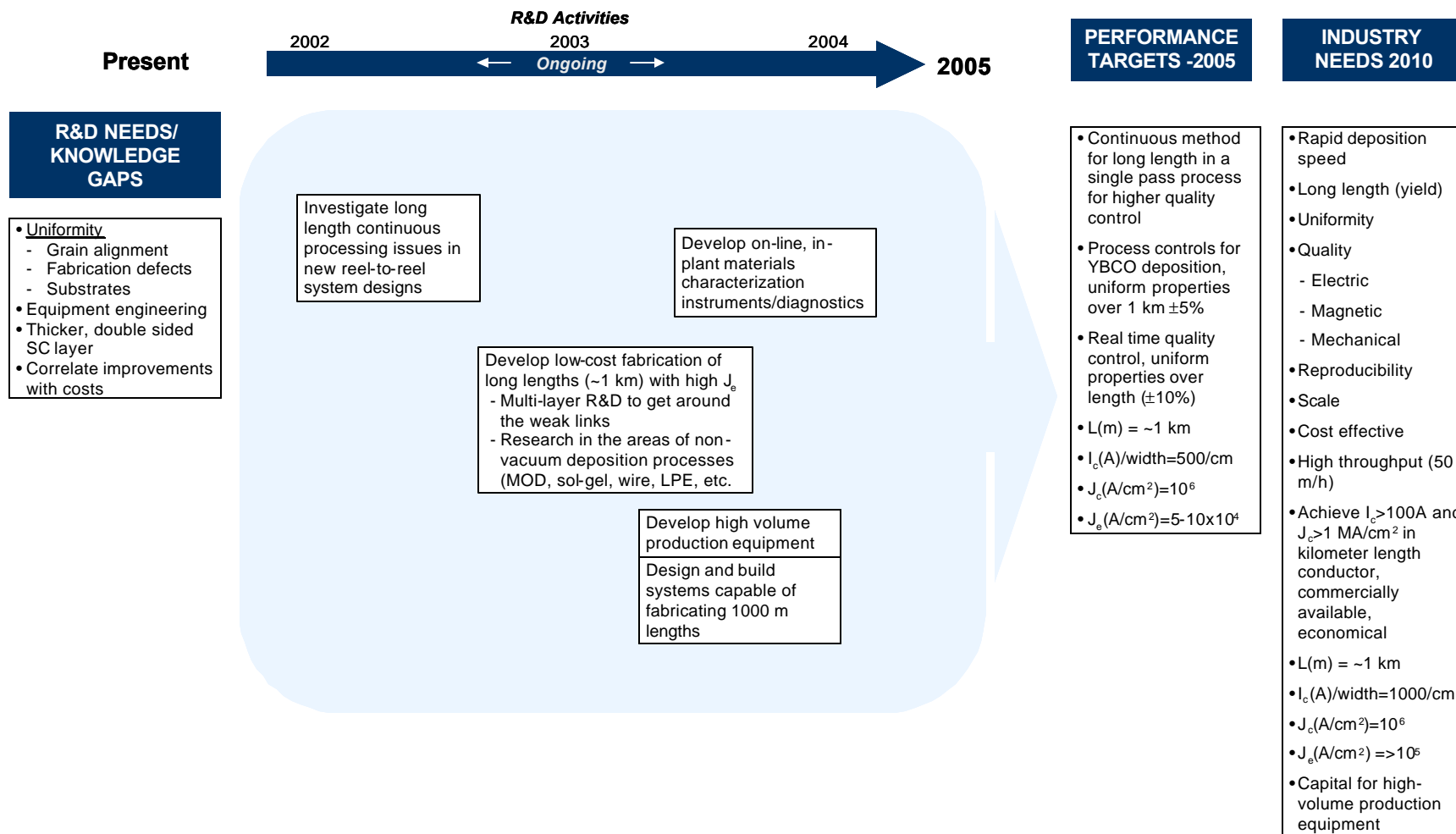
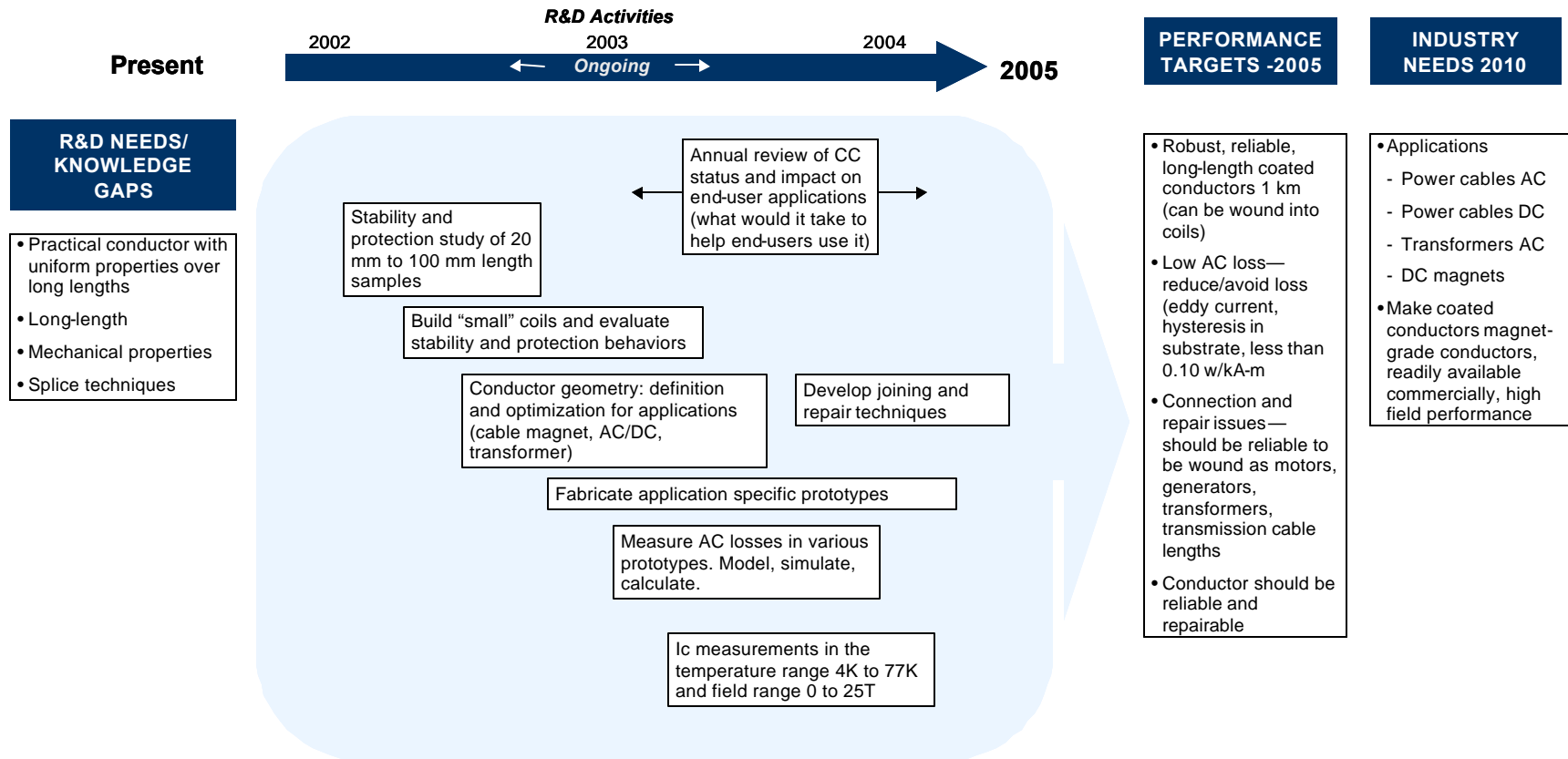

Exhibit 5.9 End-User Applications (Industry-Led)



6.0 The Road Ahead

This roadmap sets forth the priority R&D activities and the direction that will lead to the economical commercial manufacturing of high-temperature superconducting coated conductors for electric power applications.

As the exhibits in Section 5 demonstrate, virtually all the “R&D Activities” require coordination. HTS coated conductor development is considered to be a prime opportunity for organizations to work together. This roadmap will be used as a foundation for pursuing collaborative projects to achieve the vision. Continuous processing needs to be set up at the national laboratories so they can act as the advance team or “technology scouts” to reduce risks and costs to the private sector. Expertise and capabilities need to be transferred to private companies. The national laboratories develop the scientific and materials processing understanding underlying the technology. The laboratories strengthen and expand their capabilities by working with universities in research aimed at addressing fundamental technological issues. The laboratories also work closely with industry by providing access to facilities and equipment and by arranging technical personnel exchanges. Successful technology transfer requires a team effort from national laboratory facilities and industry. For example, both Oak Ridge National Laboratory and Los Alamos National Laboratory have set up separate high quality laboratory spaces for use by DOE laboratories and their industrial partners. The laboratories will develop new equipment needed for more rapid preparation and characterization of coated conductors. Industry will take the lead in any subsequent production scale-up activities as well as activities aimed at satisfying end-user application needs in the commercial marketplace.

Special efforts will be made to link the pursuit of the roadmap’s R&D performance targets and activities with the R&D activities of the DOE Superconductivity for Electric Systems Program. As a sponsor of this roadmapping effort, DOE recognizes the importance of the availability of high-quality, low-cost high-temperature superconductivity coated conductors to meet the future challenges of the electric power industry thereby enhancing U.S. energy management and efficiency and our international competitiveness.

7.0 References

“Research and Development Roadmap—Achieving Advanced Electrical Wires From Superconducting Coatings,” The University of Tennessee Space Institute, Prepared for the Office of Utility Technologies, Office of Energy Efficiency and Renewable Energy, U.S. Department of Energy, November 1997.

“Proceedings: Coated Conductor Development Roadmapping Workshop—Charting Our Course,” Energetics, Incorporated, Prepared for the Superconductivity for Electric Systems Program, U.S. Department of Energy, January 2001.

“Evaluation of Methods for Application of Epitaxial Buffer and Superconductor Layers,” Topical Report UTSI 97-02, DOE/PC/95231-11, U.S. Department of Energy, March 1999.

“Development of In-Situ Control Diagnostics for Application of Epitaxial Superconductor and Buffer Layers,” Topical Report UTSI 99-04, DOE/PC95231-24, U.S. Department of Energy, June 1999.

A. Sheth, H. Schmidt, V. Lasrado, “Review and Evaluation of Methods for Application of Epitaxial Buffer and Superconductor Layers,” *Applied Superconductivity*, Vol. 6, No. 10-12, pp. 855-873, 1999.

D.K. Finnemore, K.E. Gray, M.P. Maley, et al., “Coated Conductor Development: An Assessment,” *Physica C* 320 (1999) 1-8.

R.A. Hawsey, D.M. Kroeger, D.K. Christen, “Development of Biaxially Textured $\text{YBa}_2\text{Cu}_3\text{O}_7$ Coated Conductors in the U.S.,” *Advances in Superconductivity XII*, Proceedings of the 12th International Symposium on Superconductivity (ISS’99), October 1999.

S. Annavarapu, L. Fritzemeier, A. Malozemoff, et al., “Progress Towards a Low-Cost Coated Conductor Technology,” *M2S-HTSC- VI Superconductivity for the New Millennium Conference*, February 2000.

C.L.H. Thieme, S. Annavarapu, W. Zang, et al., “Non-Magnetic Substrates for Low Cost YBCO Coated Conductors,” *IEEE Trans. Applied Superconductivity*, September 2000.

P.N. Arendt, S.R. Foltyn, S.R. Dowden, et al., “Processing of YBCO/IBAD YSZ Coated Conductors on Flexible Substrates,” LA-UR-98-2185, July 1998.

M.P. Chudzik, R.A. Erck, U. Balachandran, et al., “High-Rate Reel-to-Reel Continuous Coating of Biaxially Textured Magnesium Oxide Thin Films for Coated Conductors,” *M2S-HTSC- VI*, February 2000.

“Superconductivity for Electric Systems—Strategic Plan FY 1998- FY 2002,” Energetics, Incorporated, Prepared for the U.S. Department of Energy, March 1999.