

Posted to MID 3/7/1998-22

U. S. DEPARTMENT OF TRANSPORTATION  
FEDERAL AVIATION ADMINISTRATION

6340.27 CHG 5
------------------

12/4/1998

RADAR FACILITIES AND EQUIPMENT MODIFICATION HANDBOOK -  
SUBJ: AIR ROUTE SURVEILLANCE RADAR, ARSR-4

---

CHAPTER 6. ARSR-4 ENROUTE MODE-S ANTENNA  
BEAM NARROWING

1. PURPOSE. This modification provides instructions for installing the modification to suppress the Sum pattern of the ARSR-4 En Route Mode-S Antenna beyond the 3 dB points to maintain an effective beamwidth of 2.4 degrees. This modification also provides steps to further optimize the ARSR-4 beacon processor to reduce the occurrences of beacon track jumps and improve mode C validation.
2. DISTRIBUTION. This directive is distributed to selected offices and services within Washington headquarters, regional Airway Facilities divisions, the William J. Hughes Technical Center, the Mike Monroney Aeronautical Center, and Airway Facilities field offices having the following facilities/equipment: ARSR-4 (3D).
3. WITHDRAWALS. None.
4. REFERENCES.
  - a. Order 6340.27, Radar Facilities and Equipment Modification Handbook - Air Route Surveillance Radar, ARSR-4.
  - b. Configuration Control Decision (CCD) No. 20597, ARSR-4 Beacon Processor Hardware Modifications at Air Route Surveillance Radar (ARSR-4) Facilities.
  - c. Instruction Book, TI 6360.95, Troubleshooting Support Data Field Maintenance Mode S En Route Antenna Single Array Configuration, Type FA-10250, Volume I, Part B.
  - d. Instruction Book, TI 6340.30, Troubleshooting Support Data Field Maintenance ARSR-4 System, Type FA-10317, Type FA-10318, Type FA-10319, Type FA-10320, Section 1 - 10, Volume 1.
  - e. Instruction Book, TI 6340.35, Troubleshooting Support Data Field Maintenance ARSR-4 Data Processor (Unit 6), Type FA-10312, Section 11, Volume 2.
  - f. Instruction Book, TI 6360.70, Air Traffic Control Beacon Interrogator Model 5, ATCBI-5, Type FA-9400.

---

Distribution: Selected Airway Facilities Field  
and Regional Offices, ZAF-605

Initiated By: AOS-230

5. BACKGROUND.

a. The New York Air Route Traffic Control Center, ARTCC, (ZNY) contacted, the National Airway Systems Engineering Division, AOS-200, Surveillance Branch, AOS-230 for assistance with improving the beacon service from the Gibbsboro, NJ ARSR-4 (QIE). The ZNY controllers reported problems with beacon track jumps and beacon target drops from QIE. In some cases, the ZNY controllers implemented miles in trail restrictions.

b. The problems are a result of multiple aircraft being in close proximity (range and azimuth) to each other and the beacon replies interfering or garbling with each other. This is an inherent problem with the broadcast type of interrogation system used in the ATCBI-5 and the sliding window detection system used in the ARSR-4.

c. This modification will increase resolution between targets in azimuth by suppressing the Sum pattern of the ARSR-4 En Route Mode-S Antenna beyond the 3 dB points to maintain an effective beamwidth of 2.4 degrees. The beacon target runlength will be reduced by approximately fifty percent as a result of this modification.

d. This modification has been successfully tested at the Gibbsboro, NJ, and Riverhead, NY, ARSR-4 facilities in the Eastern Region.

6. APPLICATION. This modification applies to all ARSR-4 facilities.

7. MATERIALS REQUIRED. The following materials are required to modify each ARSR-4 Enroute Mode-S antenna.

Description	NSN	Quantity
a. ARSR-4 Mode-S Antenna, Beam Narrowing Modification Kit		2 each
b. Splitter, 3 dB, RLC Electronics, Inc. pn D-0715-2	5985-01-457-9276	1 each
c. Adapter, N-Type Female Bulkhead to SMA Male, Pasternack Enterprises pn PE9487	5935-01-457-9278	1 each
d. 2 dB Fixed Attenuator, Weinschel Corp., pn 1N6N-2	5985-01-457-9268	1 each
e. W51A, SLS Port Cable	5995-01-457-9302	1 each
f. W51B, Difference Port Cable	5995-01-457-9303	1 each

8. SOURCE OF MATERIALS. The Surveillance Branch, AOS-230, plans to install this modification in parallel with several other ARSR-4 modifications. AOS-230 will supply the modification kit and spares at the time of installation. Do not requisition materials from the Supply Management Division, AML-600. KITS SHALL BE USED ONLY FOR MODIFYING THE EQUIPMENT STATED IN PARAGRAPH 6 OF THIS CHAPTER.

9. SPECIAL TOOLS AND TEST EQUIPMENT REQUIRED. The following tools are required to modify each ARSR-4 Enroute Mode-S antenna.

- |  |                  |        |
|--|------------------|--------|
| a. Wrench, Torque, available LIS   | 5120-01-168-9451 | 1 each |
| b. A-N Connector Pliers,<br>Specialized Products Company<br>part number (pn) 098X174 |                  | 1 each |
| c. MX-6A Card  | 5998-01-419-9133 | 1 each |

10. MODIFICATION TO BE PERFORMED BY. Field maintenance personnel, AOS-230, or as determined by the regional Airway Facilities division.

11. WHEN MODIFICATION IS TO BE PERFORMED. As soon as practical after receipt of this directive. AOS-230 will coordinate modification installation schedule with the regions.

12. ESTIMATED TIME REQUIRED. One person, 4 hours.

13. DISPOSITION OF SURPLUS PARTS. Retain all surplus parts, these will be needed for the Air Traffic Control Beacon Interrogator Model 6, ATCBI-6.

14. MODIFICATION PROCEDURE. Read the entire procedure before proceeding with this modification.

a. Modification preparation.

(1) Coordinate downtime with Air Route Traffic Control Center personnel for a cold start to ensure that no unwanted parameter settings are burned to PROM.

(2) Capture current system configuration using the Record Remote Monitor Subsystem (RECRMS) software provided in Order 6340.27, Radar Facilities and Equipment Modification Handbook - Air Route Surveillance Radar, ARSR-4, chapter 1.

(3) Request a Host Quick Analysis of Radar Sites (QARS) from Air Route Traffic Control Center for a half hour period following the cold start.

(4) Record a half hour MX-6A data recording using the software and RS-530 MX-6A cable provided in Order 6340.27, chapter 1. Store this file as a baseline.

b. Modification procedure. Coordinate four hours of downtime with Air Route Traffic Control Center personnel.

- (1) Turn off the interrogator of both channels of the ATCBI-5.
- (2) Access radome area in accordance with TI 6340.30, paragraph 3.4.1.1.
- (3) Disconnect SLS port cable, W51, from the SLS Filter using A-N Connector Pliers, see TI 6360.95, Figure 7-9, Array Bulkhead Cables and Input/Output Connections.
- (4) Using a 11/16-inch wrench disconnect cable W63 from the Array Bulkhead, see TI 6360.95, figure 7-9.
- (5) Using a  $\frac{3}{4}$ -inch wrench disconnect cable W51 from the Array Bulkhead, see TI 6360.95, figure 7-9. Retain W51 in spares inventory. W51 will be required when the Air Traffic Control Beacon Interrogator Model 6, ATCBI-6, is fielded.
- (6) Using a  $\frac{3}{4}$ -inch wrench connect N-Type Female Bulkhead (item 7c) to SMA Male Adapter provided in modification kit, (item 7a) to the Array Bulkhead, see TI 6360.95, figure 7-9.
- (7) Using a 11/16-inch wrench connect cable W63 to the Array Bulkhead, see TI 6360.95, figure 7-9.
- (8) Using a torque wrench connect input to 3 dB splitter (item 7b) provided in modification kit to the N-Type Female Bulkhead to SMA Male Adapter in step 6.
- (9) Using torque wrench connect cable SLS Port Cable W51A (item 7e) to right output of 3 dB splitter in step 8 and SLS Filter using an A-N Connector Pliers, see TI 6360.95, figure 7-9A.
- (10) Using A-N Connector Pliers disconnect cable Difference Port Cable W52 or 50 ohm termination, depending on site configuration, from Difference filter, see TI 6360.95, figure 7-9.
- (11) Using A-N Connector Pliers connect 2 dB fixed attenuator, (item 7d) to difference filter, see TI 6360.95, figure 7-9A.
- (12) Using torque wrench connect cable Difference Port Cable W51B (item 7f) to left output of 3 dB splitter in step 8 and Difference Filter using A-N Connector Pliers, see TI 6360.95 figure 7-9A.
- (13) Exit radome in accordance with TI 6340.30, paragraph 3.4.1.2.
- (14) Turn on the interrogator on both channels of the ATCBI-5.
- (15) Set the omnidirectional to directional power ratio to 1:1. For example, if the facility reference data file (FRDF) directs the directional peak power to be 58 dBm at the directional coupler out of the beacon cabinet, adjust the omnidirectional power to 58 dBm while maintaining 58 dBm of directional power.

**NOTE:** Annotate change in SLS power on FRDF referencing this modification.

All cavities are capable of a 1:1 power ratio. It may be necessary to perform steps 73 through step 77 in TI 6360.70, transmitter bias setup and cavity tuning procedure.

(16) Log on to the Local Display Console (LDC), and take control at menu 1.1.

(17) From RMS menu 5.3.1, BCN INTERROGATE/REPLY CRITERIA, page 1, enter the following parameters:

DETECTION WINDOW N:	<b>12</b>	(5 TO 20)
SUCCESSIVE INTERROGATIONS W/O ASSOCIATING TGT REPLY:	<b>8</b>	(4 TO 8)
TOTAL MATCHING REPLIES TO DECLARE MODE VALID FOR REPORT:	<b>1</b>	(1 TO 6)
TOTAL MISSED CODE MATCHES BEFORE SPLIT INTO 2 TARGETS:	<b>4</b>	(1 TO 12)

(18) From RMS menu 5.3.1, BCN INTERROGATE/REPLY CRITERIA, page 2, enter the following parameters:

MODE	HITS
	(1 TO 15)
MODE 2	<b>3</b>
MODE 3/A	<b>3</b>
MODES 3/A AND 2	<b>5</b>
MODES C	<b>2</b>
MODES C AND 2	<b>5</b>
MODES C AND 3/A	<b>3</b>
MODES 3/A AND 2 AND C	<b>6</b>

(19) From RMS menu 5.3.2.1, RUNLENGTH AND STROBE PARAMETERS, enable the runlength discrimination processing.

(20) From RMS menu 5.3.2.1, RUNLENGTH BY SECTOR, page 1, enter the following parameters for sector 1:

	SEC 1	SEC 2	SEC 3	SEC 4	
AZ START	<b>0.00</b>	0.00	0.00	0.00	(0 TO 359.98 DEG @ 0.02)
AZ STOP	<b>359.98</b>	0.00	0.00	0.00	(0 TO 359.98 DEG @ 0.02)
RNG START	<b>0.00000</b>	0.00000	0.00000	0.00000	(0 TO 250 NMI @ 0.03125)
RNG STOP	<b>150.00000</b>	0.00000	0.00000	0.00000	(0 TO 250 NMI @ 0.03125)
SRB	<b>6</b>	0	0	0	(0 TO 32 ACP's)
LRB	<b>55</b>	0	0	0	(7 TO 128 ACP's)
ENABLE	<b>1</b>	0	0	0	(1=ENABLE, 0=DISABLE)

Ensure that the runlength discrimination for all other sectors are disabled.

(21) From RMS menu 5.3.4, BEACON DETECTION MODES, ensure that both detection mode and interrogated mode is equal to Modes 3/A, 2, and C.

(22) From RMS menu 5.3.5.1, BEACON TOLERANCE VARIABLE, enter the following parameters:

```
BRACKET TOLERANCE:          2  (+/- 1 TO 3 RANGE CELL)
CODE DATA SAMPLING TOLERANCE: 2  (+/- 1 TO 2 RANGE CELL)
GARBLE TOLERANCE:          2  (+/- 2 OR 4 RANGE CELL)
MAXIMUM PULSEWIDTH BEFORE:  8  (8 OR 9 RANGE CELL)
  TRAIL EDGE DETECTION
```

(23) From RMS menu 5.3.7, BEACON SPLIT PROCESSING, enter the following parameters:

```
SPLIT PROCESSING:      ON      (ON/OFF)

RANGE WINDOW:         64      (0 TO 64 1/256 NMI)
AZIMUTH WINDOW:       108     (0 TO 108 iACP's)
AGE:                  400     (0 TO 512 iACP's)

                                WEIGHTS
SHORTEST RANGE:      2      (0 TO 3)
VALID 3/A CODE:      0      (0 TO 3)
VALID C CODE:        1      (0 TO 3)
LARGEST HIT COUNT:   3      (0 TO 3)
```

(24) From RMS menu 5.3 BEACON PROCESSOR PARAMETERS, load changes.

(25) From RMS menu 5.4.1, RANGE/AZIMUTH PRIORITIES, enter the following parameters:

#### 5.4.1 RANGE/AZIMUTH PRIORITIES

MODE	BSR	BSR
	RANGE PRIORITY (1,2,3)	AZIMUTH PRIORITY (1,2,3)
BEACON	1	1
SEARCH	2	2
MODE 4	3	3

**NOTE:** EACH MODE SHOULD HAVE, BUT DOES NOT REQUIRE, ITS OWN UNIQUE PRIORITY.

(26) From the RMS menu 5.4.2, PROXIMITY, INTERVAL, RUNLENGTH ENABLE, enter the following parameters:

#### 5.4.2 PROXIMITY, INTERVAL, RUNLENGTH ENABLE

```
PROXIMITY >>  BSR RANGE WINDOW:      0.25000 (0 TO 8 NMI @ 0.03125)
                BSR AZIMUTH WINDOW:   76.00 (0 TO 512 iACPs @ 0.25)

INTERVAL  >>  BSR REPORT AGE:          512 (0 TO 1023 iACPs)
                BSR PURGE INTERVAL:    256 (64 TO 1024 iACPs @ 64)
                BSR RUNLENGTH OVERLAP TEST ENABLED:  0 (1 = YES, 0 = NO)
```

(27) From RMS menu 5.4, MERGE PROCESSING, load changes.

(28) From RMS menu 1.2.7, EEPROM AND GRAM CONFIGURATION, command EEPROM B to lock.

(29) From RMS MAIN MENU, backup SAP/FAPS to PROM.

(30) From RMS menu 1.2.7, EEPROM AND GRAM CONFIGURATION, command EEPROM B to stby.

(31) From RMS menu 7, DISK OPERATIONS, mount the disk.

(32) From RMS menu 7.3, PARAMETER AND CONFIGURATION SEGMENTS, enter the data mode by typing **CTRL, D**, enter **BCNMOD** for the filename and press return, then enter the command mode by typing **CTRL, C**.

(33) From RMS menu 7.3, PARAMETER AND CONFIGURATION SEGMENTS, store the SAPS/FAPS file to disk by using option 2.

(34) From RMS menu 7, DISK OPERATIONS, park the disk.

(35) Remove the Data Collection Disk (DCD) from the left bay and insert it into the right bay.

(36) Connect the Small Computer Systems Interface (SCSI) cable to the Disk Drive Jack located in the Data Processor Cabinet on the Control Panel Assembly, see TI 6340.35 figure 11-1, and to the SCSI card located in the Gateway computer.

(37) Reboot the Gateway computer.

(38) Type in the following commands:

```
d: <enter>
attrib -r freelist <enter>
del freelist <enter>
copy d:\cfg_seg\bcnmod.nap d:\sys_seg\a4oc-a01.nap <enter>
```

DOS will prompt for confirmation to overwrite the existing file. Type **Y** for yes.

(39) Disconnect the SCSI cable from the data processor and the Gateway computer.

(40) Move the DCD from the right bay to the left bay.

(41) From RMS menu 7, DISK OPERATIONS, mount the disk.

(42) On both channels of the ATCBI-5 set the interlace to XYZ.

(43) On both channels of the Integral System Monitor (ISM) load the nominal power on address 06 to reflect the change in step 15.

(44) On both channels of the ISM load the nominal interlace on address 17 to 3250.

#### 15. TEST AFTER MODIFICATION.

a. Record a 30 minute MX-6A data recording using the software and RS-530 MX-6A cable provided in Order 6340.27, Radar Facilities Equipment Modification Handbook Air Route Surveillance Radar, ARSR-4, chapter 1.

b. Playback the file recorded in step 15a, with the PLOTCD software.

c. Via the PLOTCD software, press **Alt-F5** for statistics and analyze the beacon Runlength VS Target Distribution plot. Press **N**, to view results on display.

d. If the mean runlength is between 23 and 29 ACP's, the modification is complete.

e. If the mean runlength is greater than 35 ACP's remove modification parts and repeat steps 14(8) through 14(12) with the spare parts provided in the modification kit. Order a spare modification kit through AOS-230.

f. If the mean runlength is greater than 29 ACP's increase omnidirectional power in 1 dB steps while maintaining the directional power at the FRDF value, repeat steps 15a through 15d.

g. If the mean runlength is less than 23 ACP's decrease omnidirectional power while maintaining directional power at the FRDF value, repeat steps 15a through 15d.

h. Have the ARTCC personnel certify the beacon and radar service. Request a copy of the Host QARS and store with baseline results.

16. RESULT OF MODIFICATION. This modification causes the average beacon runlength to be reduced approximately fifty percent without impacting detection. Shorter runlengths result in fewer occurrences of overlapping or garbled beacon replies. The end result is that beacon target drops, beacon track jumps, and erroneous altitude reporting are greatly reduced.



17. CHANGES TO INSTRUCTION BOOKS.

## PAGE CONTROL CHART

Remove Pages	Dated	Insert Pages	Dated
TI 6360.95 Volume I, Part B			
vii and viii	Undated	vii viii	12/4/1998 Undated
7-15 and 7-16	Undated	7-15 7-16	Undated 12/4/1998
7-17 and 7-18	Undated	7-17 7-18	Undated 12/4/1998
		7-18A/7-18B(Blank)	12/4/1998
8-19 and 8-20	Undated	8-19 8-20	12/4/1998 Undated

18. CHANGES TO INSTALLATION DRAWINGS. None.

19. CHANGES TO RECORDED DATA. Enter this directive number, date, and chapter number on the appropriate FAA Form 6032-1, Airway Facilities Modification Record.

20. CHANGES TO TABLE OF CONTENTS. This chapter will be included in the next revision to the table of contents for Order 6340.27.

21. RECOMMENDATIONS FOR CHANGES. Forward any recommendations for changes to this directive through normal channels to the National Airway Systems Engineering Division, AOS-200, Operational Support.

*for*   
George W. Terrell  
Program Director for Operational Support

Attachments (Instruction Book Changes)



VOLUME I - PART B  
LIST OF FIGURES  
(CONTINUED)

<u>Figure</u>	<u>Title</u>	<u>Page</u>
1-4	Typical Sum, Difference and SLS Elevation Pattern .....	1-6
1-5	Sum Azimuth Pattern at +6 Degrees Elevation-1030 MHz.....	1-7
1-6	Difference Azimuth Pattern at +6 Degrees Elevation-1090 MHz.....	1-8
1-7	SLS Azimuth Pattern at +6 Degrees Elevation-1030 MHz.....	1-9
1-8	Filter Set (Matched Set of 3).....	1-10
1-9	SLS Support Backstructure .....	1-11
1-10	Probe Assembly.....	1-12
2-1	Typical Sum and Difference Azimuth Radiation Patterns at +6 Degrees Elevation-1090 MHz.....	2-4
2-2	Typical Sum and SLS Azimuth Radiation Patterns at +6 Degrees Elevation-1030 MHz.....	2-5
2-3	Detailed Wiring Diagram .....	2-8
2-4	Signal Flow for Sum (Directional) Input.....	2-9
2-5	Signal Flow for Difference (Monopulse) Input.....	2-10
2-6	Signal Flow for SLS Input.....	2-17
2-12	Dipole Column .....	2-18
2-13	SLS Attenuator .....	2-19
2-14	Filter Set (Matched Set of 3).....	2-24
4-1	Dipole Column Reference Designators.....	4-2
6-1	VSWR Measurement Test Setup.....	6-3
6-2	Electric Field Strength Measurement Equipment Setup.....	6-5
6-3	Probe Assembly Use .....	6-7
7-1	Simplified Functional Block Diagram.....	7-2
7-2	Detailed Wiring Diagram .....	7-4
7-3	Troubleshooting Flowchart (Sum) .....	7-5
7-4	Troubleshooting Flowchart (Difference).....	7-8
7-5	Troubleshooting Flowchart (SLS).....	7-11
7-6	Amplitude and Phase Tracking Test Set Up.....	7-12
7-7	Access to the Antenna (Top View) .....	7-14
7-8	Shroud Removal.....	7-15
7-9	Array Bulkhead Cables and Input/Output Connections.....	7-17
* 7-9A	Array Bulkhead Cables and Input/Output Connections for ARSR-4 with ATCBI-5.....	7-18A *
7-10	Matrix Input/Output Cable Location.....	7-20
7-11	Matrix and Cable Connections.....	7-23
7-12	Attenuator Assembly .....	7-26
7-13	Detailed Wiring Diagram .....	7-29
7-14	Cable Location-Matrix to Nine-Way Power Dividers.....	7-30
7-15	Nine-Way Power Divider Mounting.....	7-33

VOLUME I - PART B  
 LIST OF FIGURES  
 (CONTINUED)

<u>Figure</u>	<u>Title</u>	<u>Page</u>
7-16	Cable Connection to Column .....	7-35
7-17	Dipole Column Replacement.....	7-40
7-18	Ground Plane Replacement. ....	7-42
7-19	SLS Support Backstructure Components.....	7-45
7-20	Dipole Column Reference Designators.....	7-51
7-21	Input Connector Markings... ..	7-52
9-1	Shipping Crate.....	9-3
9-2	Antenna Lifting Configuration.....	9-4
9-3	Support Weldment Attachment to Shipping Crate.....	9-5
9-4	Work Platform Leveling.....	9-7
9-5	Tilt Adjustment.....	9-9
9-6	RF Cable Installation.....	9-10
9-7	SLS Attenuator Connection. ....	9-12
9-8	SLS Amplitude Effects on Radiation Signal, at 00 Phase.....	9-13
9-9	Typical SLS Radiation Signal.....	9-15
11-1	Array Assembly.....	11-2
11-2	SLS Support Backstructure . ....	11-4
11-3	Work Platform.....	11-5
11-4	Turnbuckle Actuator.....	11-7

LIST OF TABLES

<u>Table</u>	<u>Title</u>	<u>Page</u>
1-1	Reference Data .....	1-14
1-2	Mode S Antenna Principal Electrical Characteristics.....	1-14
1-3	Mode S Antenna Elevation Radiation Pattern Characteristics.....	1-15
1-4	Mode S Antenna Azimuth Radiation Pattern Characteristics.....	1-17
1-5	Mode S Antenna Principal Mechanical Characteristics.....	1-19
1-6	Low-Pass Filters - Principal Parameters.....	1-19
1-7	Equipment Supplied .....	1-20
1-8	Equipment Supplied Separately .....	1-21
1-9	Equipment Required But Not Supplied.....	1-22
2-1	Theoretical Nominal Dipole Excitation.....	2-6
2-2	Theoretical Dipole Column Azimuth Excitations.....	2-7
2-3	Coaxial Cable Description... ..	2-21
4-1	Mechanical Standards and Tolerances .....	4-3
4-2	Hardware Information and Torque Requirements.....	4-4
4-3	VSWR Requirements .....	4-5
4-4	Sum Channel Dipole Excitation Levels.....	4-6
4-5	SLS Channel Dipole Excitation Levels.....	4-12
4-6	Difference Channel Dipole Excitation Levels.....	4-13

UPPER SHROUD HARDWARE

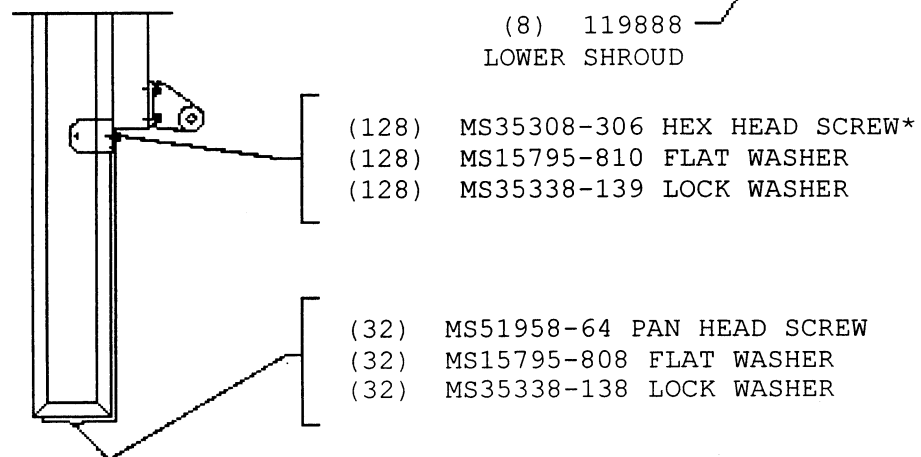
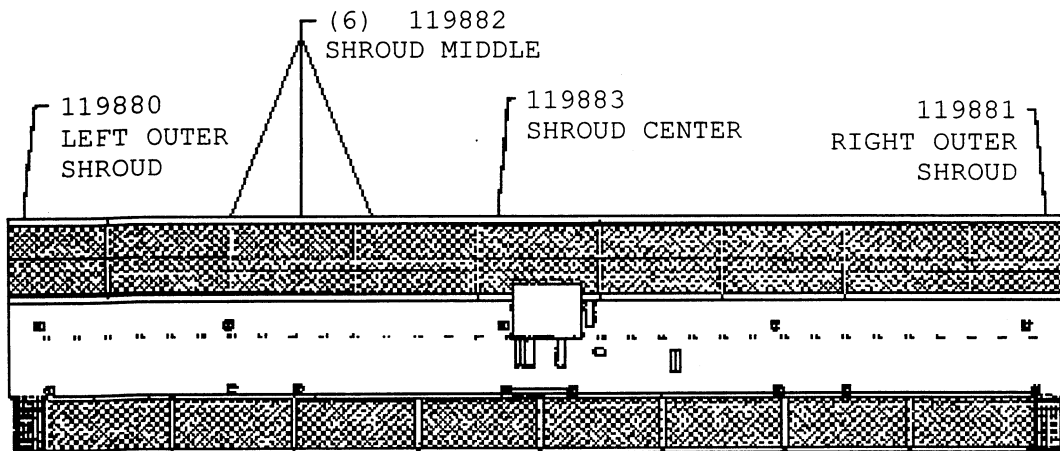
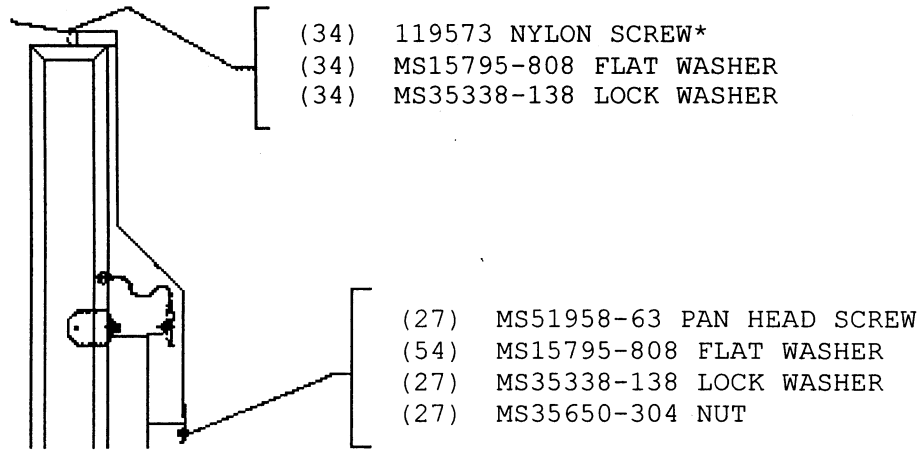

LOWER SHROUD HARDWARE

\* USE NEW REPLACEMENT SCREWS WHEN REINSTALLING SHROUD(S).

Figure 7-8. Shroud Removal

**CAUTION**

**Duplicate all bends of any cables being replaced. The minimum bend radius for the 0.141-inch cable is 0.5 inch. The minimum bend radius for the 0.25-inch cable is 1.25 inches.**

7.4.1 Array Bulkhead Cables (W51, W52, W53, and W54).- The cables between the array bulkhead and the filters or matrix bulkhead are replaceable if troubleshooting procedures indicate that one of them is defective. The connectors are permanently attached to the cables. Perform the steps as follows using figure 7-9 or 7-9A. The following tools/materials are required \* to perform this replacement:

Connector pliers (padded jaws)  
3/4" open-end wrench  
Silicone rubber (Dow Corning, RTV-3140)

- (1) Disconnect the RF input cable from the appropriate connector on the array bulkhead.
- (2) For the cable being replaced, remove the type N bulkhead connector from the array bulkhead by removing the hex nuts and star washers.
- (3) Disconnect the cable from the filter or matrix bulkhead connector.

**CAUTION**

**Duplicate all bends of any cables being replaced. The minimum bend radius for the 0.141-inch cable is 0.5 inch. The minimum bend radius for the 0.25-inch cable is 1.25 inches.**

- (4) Bend the replacement cable to duplicate all bends of the cable being replaced.
- (5) Mount the type N bulkhead connector on the replacement cable to the array bulkhead. Tighten securely.
- (6) Connect the type N straight connector to the filter or matrix bulkhead connector. Tighten securely.
- (7) Refer to troubleshooting charts (figures 7-3, 7-4, and 7-5) to perform appropriate checks to verify that the replacement part is functional.
- (8) Reconnect the RF cable to the array bulkhead connector. Tighten securely.
- (9) Provide a vapor seal on all mated connectors. Coat the mated connectors with silicone rubber(Dow Corning, RTV-3140).

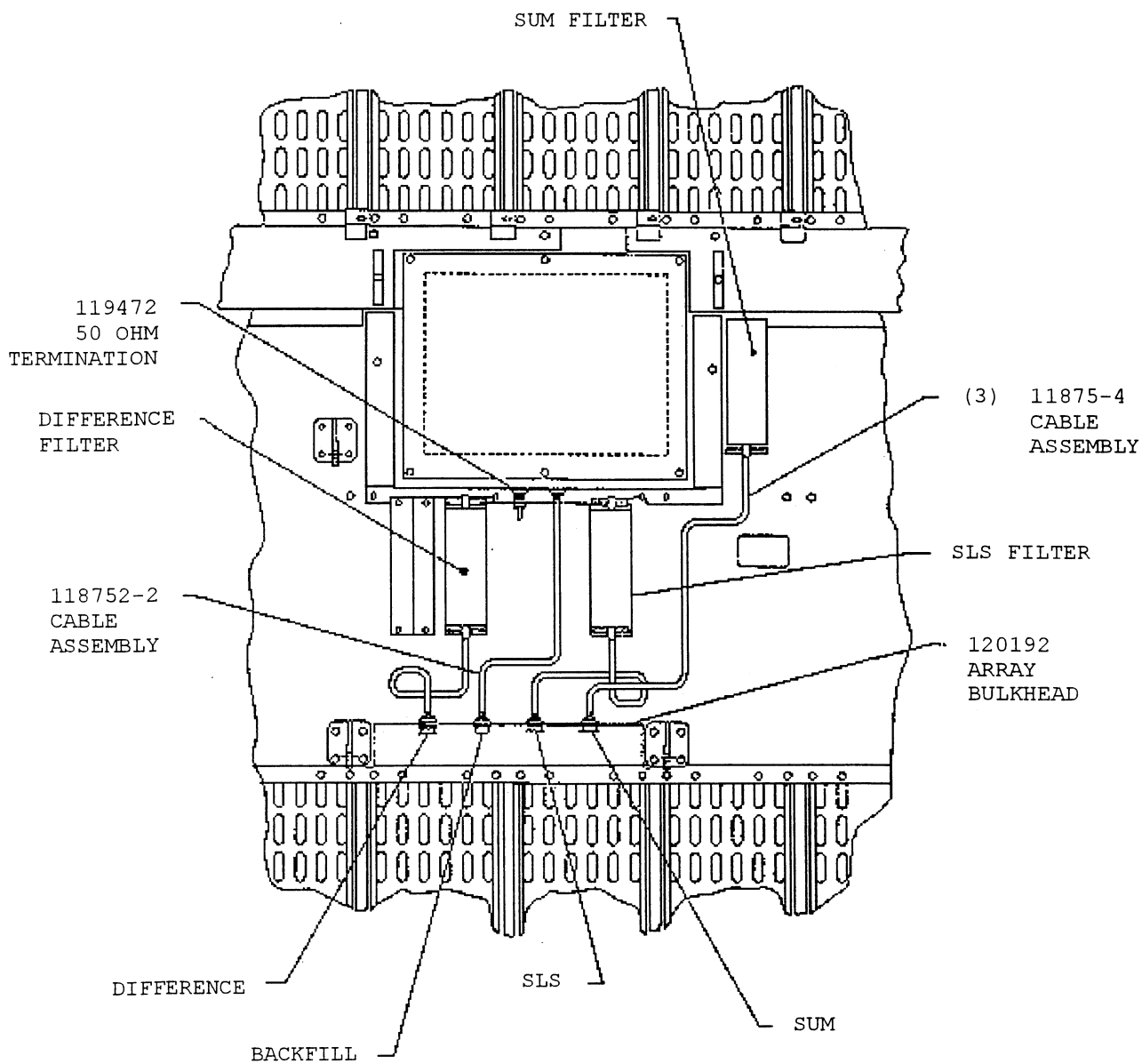

Figure 7-9. Array Bulkhead Cables and Input/Output Connections

7.4.2 Filter Replacement. - The Type FA 10250/3 matched filter set (p/n 118653) is replaceable. The filter set is a matched set of three low-pass filters. If a failure occurs in one filter, all three must eventually be replaced. To verify amplitude and phase tracking of the filters within a set, perform the procedure described in paragraph 7.3.4.1.

**NOTE**

**To avoid downtime, if the sum and difference filters are not matched but are still operational, check the SLS filter for proper match and substitute for the unmatched sum or difference filter.**

\* Refer to figures 7-8, 7-9, and 7-9A. The following tools/materials are required to perform this replacement: \*

Screwdriver set, flat blade  
Screwdriver set, Phillips head  
Connector pliers (padded jaws)  
Torque wrench in-lb graduations  
7/16" Torque wrench head  
3/8" open-end wrench  
7/16" open-end wrench  
7/16" socket  
3/8" drive ratchet  
3" socket extension  
Silicone compound (Dow Corning, DC-4)  
Silicone rubber (Dow Corning, RTV-3140)

- (1) Disconnect the cable (extending from the array bulkhead) at the filter that is being replaced.
- (2) For access to the sum filter, remove the center shroud as described in steps 3 and 4. It is not necessary to remove any shrouds for access to the SLS and difference filters.
- (3) Remove four (4) each nylon screws (p/n 119573), MS35338-138 lock washers, and MS15795-808 flat washers securing the top of the center shroud to the ground planes. Retain the lock washers and flat washers. Use new nylon screws when re-installing the shroud.
- (4) Remove and retain three (3) MS51958-63 pan head screws, six (6) MS15795-808 flat washers, three (3) MS35338-138 lock washers and three (3) MS35650-304 hex nuts securing the back of the center shroud to the inner left and inner right bulkheads. Remove the center shroud.
- (5) Remove and retain two (2) each MS35308-305 hex head screws, MS35338-139 lock washers, and MS15795-810 flat washers securing the filter to the backstructure (p/n 118730). Support the filter while removing the retaining hardware.



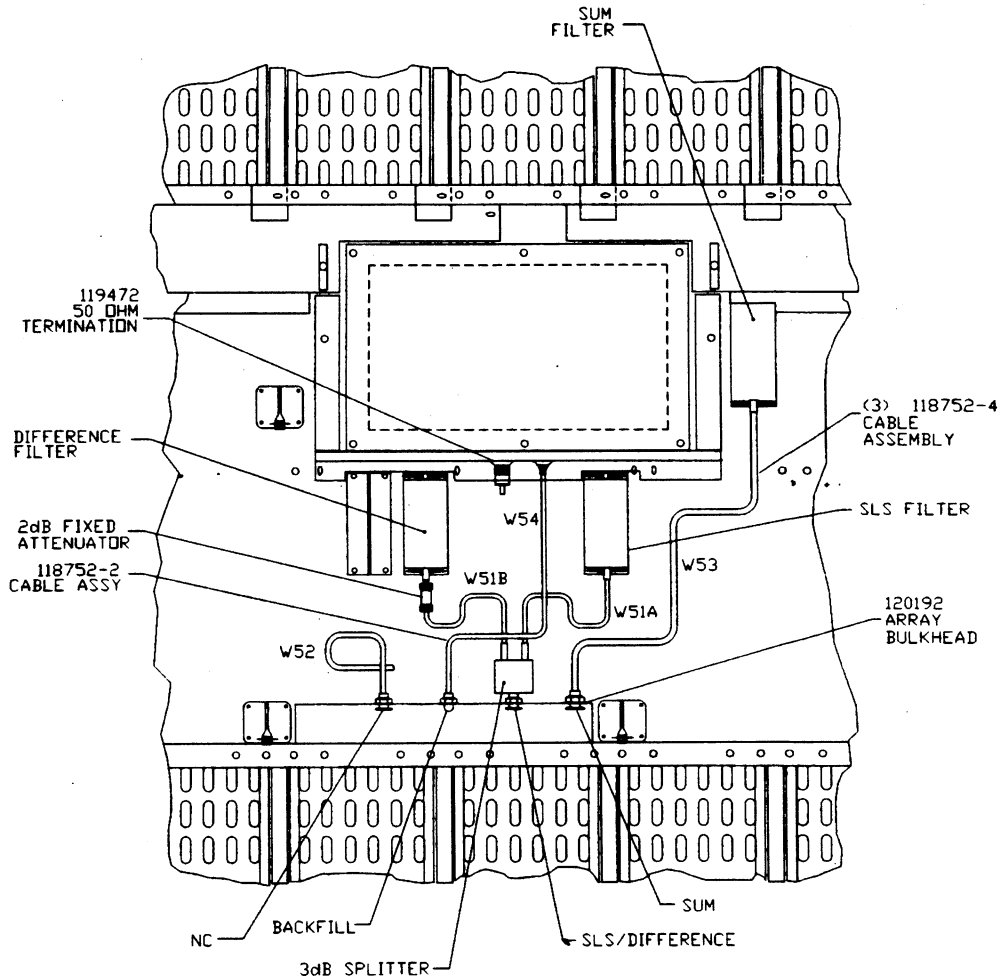

Figure 7-9A. Array Bulkhead Cables and Input/Output Connections for ARSR-4 with ATCBI-5



TABLE 8-1. PARTS LIST

Reference Designator	Indent Level	Part Name/Description	Mfrs. Code #	Manufacturer's Part #	Notes
6A16W51	B	Cable Assembly (SLS Filter to Array Bulkhead)	19564	118752 - 4	
6A17W52	B	Cable Assembly (Difference Filter to Array Bulkhead)	19564	118752 - 4	
6A18W53	B	Cable Assembly (Sum Filter to Array Bulkhead)	19564	118752 - 4	
6A19W54	B	Cable Assembly (Matrix Bulkhead to Array Bulkhead)	19564	118752 - 2	
6A20	C	Field Maintenance Kit	19564	119253 - 1	
6A20A1	D	Probe Assembly	19564	118780	
6A20A1U1	D	Harness Assembly - Probe Box	19564	119480	
6A20A1U2	D	Switch Box Assembly	19564	118781	
6A20A1U3	D	Probe Box Assembly	19564	119494	
6A20A1U4	C	Power Cable	19564	119493	
6A20W44	C	Attenuator Cable (450)	19564	115123 - 2	
6A20W45	C	Attenuator Cable (900)	19564	115123 - 3	
6A20W46	C	Attenuator Cable (1350)	19564	115124 - 1	
6A20W47	C	Attenuator Cable (1800)	19564	115124 - 2	
6A20MPI	C	Workplatform Mat	19564	119866 - 1	
6A20MP2	C	Workplatform Mat	19564	119866 - 2	
6A20MP3	C	Workplatform Mat	19564	119866 - 2	
6A20MP4	C	Walkway, Access	19564	118735	
6A20MP5	C	Walkway, Access	19564	118735	

ITEMS SUPPLIED AS PART OF THE BEAM NARROWING MODIFICATION FOR USE WITH AN ARSR-4 EQUIPPED WITH AN ATCBI-5

- 6A16W51A Cable Assembly (3 dB Splitter to SLS filter)
- 6A16W51B Cable Assembly (3 dB Splitter to 2 dB Fixed Attenuator)
- 6A16AT1 2 dB Fixed Attenuator
- 6A16A1 3 dB Splitter

- NSN 5995-01-457-9302
- NSN 5995-01-457-9303
- NSN 5985-01-457-9268
- NSN 5985-01-457-9276 \*

\*

TABLE 8-2. TABLE OF MANUFACTURERS

Federal Supply Code	Name and Address
19564	COMSAT RSI Technical Products 1501 Moran Road Sterling, VA 22170
28983	Daico Industries P.O. Box 5225 Compton, CA 90220
51719	Delta Microwave 840 Via Alondra Camarillo, CA 93010