

**NASA Contractor Report 1 8 1 7 2 6**

**ADVANCED PILOTED AIRCRAFT FLIGHT  
CONTROL SYSTEM DESIGN METHODOLOGY  
VOLUME II: THE FCX FLIGHT CONTROL  
DESIGN EXPERT SYSTEM**

(NASA-CR-181726-Vol-2) ADVANCED PILOTED AIRCRAFT FLIGHT CONTROL SYSTEM DESIGN METHODOLOGY. VOLUME 2: THE FCX FLIGHT CONTROL DESIGN EXPERT SYSTEM Final Report (Systems Technology) 190 p N89-26014  
Unclas  
CSCL 01C G3/08 0222710

**Thomas T. Myers and Duane T. McRuer**

**Systems Technology, Inc.  
Hawthorne, CA 90250**

**Contract No. NAS1-17987**

**October 1988**

**NASA**

National Aeronautics and  
Space Administration

**Langley Research Center**  
Hampton, Virginia 23665-5225

TABLE OF CONTENTS

|   | <u>Page</u> |
|---|-------------|
| A. OVERVIEW OF FCX.....   | 1           |
| B. LEVEL5 EXPERT SYSTEM SHELL.....  | 4           |
| C. PROGRAM CC.....  | 5           |
| D. STRUCTURE OF THE FCX EXPERT SYSTEM.....  | 7           |
| E. GLOBAL DATA STRUCTURES.....  | 8           |
| F. FCX KNOWLEDGE BASES.....   | 10          |
| G. UTILITY PROGRAMS.....  | 30          |
| H. PROGRAM CC MACROS.....   | 33          |
| I. INSTALLATION OF THE FCX SOFTWARE.....  | 35          |
| J. INITIATING A FCX SESSION.....  | 35          |
| REFERENCES.....   | 38          |
| APPENDIX A. FCX FLIGHT CONTROL DESIGN EXPERT SYSTEM<br>KNOWLEDGE BASE LISTINGS..... | 39          |

LIST OF FIGURES

|   | <u>Page</u> |
|---|-------------|
| 1. Knowledge Base Structure in the FCX Flight<br>Control Expert System.....   | 11          |
| 2. FCX Main Menu.....   | 12          |
| 3. Aircraft Basic Data File, "ACDATA.PRM".....                                | 13          |
| 4. Flight Condition and Trim File, "FLTCOND.PRM".....                         | 15          |
| 5. Stability and Control Derivatives File, DERIVS.....                        | 16          |
| 6. Bare Airframe Model.....   | 17          |
| 7. Transfer Function File for Input to LEVEL 5, GFCX.....                     | 20          |
| 8. Open Loop Aircraft.....  | 21          |
| 9. Yaw Damper Diagram Showing Roll and<br>Yaw Rate Blending Coefficients..... | 25          |
| 10. Augmented Aircraft System Model.....                                      | 27          |

LIST OF TABLES

|   | <u>Page</u> |
|---|-------------|
| 1. Include Files and Knowledge Bases in C:\FCSXPRT..... | 36          |
| 2. Utilities and Macros in C:\STI.....                  | 36          |

## VOLUME II

### THE FCX FLIGHT CONTROL DESIGN EXPERT SYSTEM

#### A. OVERVIEW OF FCX

While the overall effort of this project has been to develop and refine a particular flight control system design methodology, a major thrust has been improved implementation of these methods in software. Here the primary focus has been on ways of extending traditional computer-aided control system design (CACSD) software by exploiting recent developments in "knowledge-based" concepts, specifically expert systems. Algorithmic CACSD software has been used in flight control system design for many years and in fact this application has been a major driver in the development of many "in-house" and commercial packages. Software support for both classical and modern control system design methods is available, but modern (in particular optimal control) approaches have received the most development. In fact modern control theory has been largely shaped to exploit what digital computers and procedural programming languages do best which has resulted in a great many sophisticated and powerful analysis and design tools. While new developments continue to appear in algorithmic CACSD (e.g., recent work in singular value based robust MIMO design methods) this line of effort has reached a certain level of maturity.

Recently new developments in computer science, in particular artificial intelligence, have created the possibility of attacking aspects of flight control design which have not been well served by algorithmic CACSD. The evolution of modern control and its implementation in software has lead to increasing generality and abstraction. While this creates a "powerful" methodology in the sense that a given algorithm can be applied to control systems arising in many disciplines, this generality is gained at the cost of a certain loss of information important in "real-world" design. By way of illustration, the numerical state space model used in an optimal control design of an FCS is not immediately distinguishable from matrices that might arise in a nuclear powerplant design. But to aircraft control system designers the physical distinctions of the plant

are obvious and of great practical importance. To an FCS designer working under deadlines on a new aircraft, the knowledge that his design methods could be applied to many other disciplines is of only academic interest. On the other hand that designer would have great interest in any approaches specific to his problem. Thus the potential for combining application specific support with the power of general algorithmic CACSD design tools is the primary promise of expert systems for design. This potential arises from the fact that expert system concepts were developed specifically for highly empirical disciplines (e.g., medical diagnosis, geological prospecting, etc.) where the deterministic mathematical models which allow generality and abstraction are very limited.

What has emerged from this project is that algorithmic CACSD is and will continue to be an essential tool in flight control system design. However, expert system software can complement (as opposed to replace) the algorithmic tools by facilitating development of more application specific software. This is the perspective from which the FCX Flight Control Design software package was developed in this project. This package "federates" two basic components: an expert system and an algorithmic computer-aided control system design (CACSD) program. The expert system has been developed in this project using the expert system "shell" program LEVEL5 by Information Builders Inc. The CACSD program is STI's Program CC Version 3 with extensions developed in this project. The expert system ordinarily acts as the intermediary between the human user and Program CC although the latter can of course be used directly.

→ The FCX expert system as presently developed is only a limited prototype capable of supporting basic lateral-directional FCS design activities related to the design example used in the project. FCX presently supports design of only one FCS architecture (yaw damper plus roll damper) and the rules are largely focused on Class IV (highly maneuverable) aircraft. Despite this limited scope, the major elements which appear necessary for application of knowledge-based software concepts to flight control design have been assembled and thus FCX represents a prototype which can be tested, critiqued and evolved in an ongoing process of development.

The fundamental problem solving paradigm on which FCX is based is a form of "generate and test" (Ref. 5). The basic procedure is to generate one or more FCS architectures which are then defined in sufficient detail to be tested against the appropriate requirements and specifications for the aircraft and flight condition. The primary role of the FCS design heuristics captured in the FCX production rules, is to insure that the designs most likely to be successful are tried first. "Most likely" is determined by long experience with the specific flight control architectures about which FCX has knowledge. This builds in a certain conservatism to FCX, but ultimately does not preclude unconventional designs if the traditional designs fail to satisfy the requirements.

This last point is related to and dependant on a somewhat broader principle that has emerged in this work as essential for expert design systems such as FCX. That is, such knowledge-based design tools should, whenever feasible, allow the user to decide what is to be at each step. Only when the user indicates that he or she does not know what to do should the system use its innate design knowledge to propose the next step or the next parameter value. FCX accommodates this principle and provides valuable service to the user in either role. To accomplish this, FCX functions at two levels: first as a natural language interface for Program CC and secondly as a FCS design expert system.

When the user specifies an action (by making a selection from a menu or providing a numerical value of a parameter), FCX acts as an "intelligent gofer" and handles the detail work in setting up appropriate models, issuing commands to Program CC, etc. In this role FCX appears as a discipline-specific natural language interface -- i.e., the user can speak to FCX in flight control jargon (e.g., "yaw damper", "rate gyro tilt angle") without having to learn the Program CC command language. This capability is essential to making the system of use to experienced flight control designers as well as novices. This latter point is very important because we believe that if expert design systems are to be of real value they must be truly useful to journeymen designers not just apprentices.

When and if the user reaches a step in the design process using FCX where he cannot make a decision when prompted, he has the option of replying "unknown" at which point FCX will search its rule base in an effort to make the decision or set a parameter value. At this point FCX actually operates as a true expert system. At the present state of development of FCX, most of the design heuristics necessary to support this mode reside in only a few of the many FCX knowledge bases. The rules in the other knowledge bases primarily support the natural language interface and are typically involved in collection of aircraft and flight condition data and transfer of data to and from Program CC. The distinction between the natural language interface elements and the design expert elements will be discussed further in connection with specific knowledge bases.

To put the FCX development into perspective it is useful to compare it to the few other applications of expert systems to CACSD so far reported (e.g., Refs. 6 and 7). Generally other proposals and developments appear to put more emphasis on modern and optimal control procedures whereas FCX emphasizes classical approaches. Consequently the other developments have a more general, more abstract focus than does FCX and thus put more emphasis on the expert system as an interface for algorithmic CACSD. The distinguishing features of this approach is that the knowledge imbedded in the expert system is knowledge about algorithms and operation of CACSD software rather than knowledge about aircraft characteristics and FCS design practice as is emphasized in FCX. We believe that the FCX implementation built on the aircraft-centered approach and classical control methods emphasized in this project comes closer to the spirit and potential of the expert system concept -- namely to take advantage of specialized information about specific systems.

#### **B. LEVEL5 EXPERT SYSTEM SHELL**

The FCX flight control design expert system element has been developed in the LEVEL5 expert system development "shell" from LEVEL5 Research, Indialantic, Florida a subsidiary of Information Builders, Inc. LEVEL5, version 1.0 for IBM-PC and compatible personnel computers has been

used for this development (Ref. 1). Despite the name change, LEVEL5 is merely the latest version of the INSIGHT 2 expert system which has been used throughout the project. LEVEL5 is also available for Apple McIntosh, DEC/VAX and IBM mainframe computers. Since the basic (uncompiled) form of LEVEL5 knowledge bases are ASCII files (called "PRL" files), the FCX expert system can be transferred to and run on any of these computers after recompiling (however, Program CC, is presently available only for IBM-PC class personal computers.)

The original motivation for using an expert system shell, such as LEVEL5, in this project, was to minimize the effort in implementation and thus keep the focus more on the flight control knowledge base development rather than the "knowledge engineering" (software design) aspects. The promise of commercial expert system shells, which were just becoming available for personal computers as the project began, was that experts could implement their expert systems without the assistance of specially trained knowledge engineers. It does appear that use of the shell avoided, or at least postponed, some of the effort that would have been expended in this project if the implementation had been done in AI languages such as LISP or PROLOG. Rather than eliminating the need for knowledge engineering capability, it is probably more accurate to say that the use of shells allow experts to begin implementation of their expert systems as they learn basic knowledge engineering principles. The LEVEL5 shell does impose certain limitations and constraints, that would not have arisen using LISP or PROLOG. But the limitations of LEVEL5 have been reasonable and have not seriously limited the initial development of the FCX at a prototype level and in fact effectively restricted the scope of the initial development to a manageable task. Other commercial expert system shells contain features and capabilities which eliminate these restrictions and provide a route to further development of FCX.

#### C. PROGRAM CC

The algorithmic CACSD element incorporated in the FCX system is STI's Program CC Version 3 which is documented in Ref. 2. The FCX LEVEL5 expert system acts as a natural language interface between the user and



Program CC. These LEVEL5-Program CC links have been mechanized by using the LEVEL5 "ACTIVATE" capability which allows external programs to be run from within a LEVEL5 knowledge base. Program CC is activated from many rules within the FCX knowledge bases. When an operation is completed in Program CC, control is returned to the calling knowledge base which continues processing rules using facts returned from Program CC. Among the basic operations performed by Program CC are construction of state space models of the bare airframe and FCS loops, generation of transfer function matrices and generation of on screen graphics such as Bode and root locus plots.

The execution by Program CC of specialized operations required by the FCX expert system is made possible by use of the Program CC "macro" capability. A Program CC macro is a series of commands which can be executed in sequence at any time by invoking the macro name as a pseudo-command. Macros may contain parameters which are specified (from calculations in a knowledge base) when the macro is invoked. Thus the FCX package includes a number of macros which perform operations such as defining the bare airframe transfer function matrix from a state space model setup in the FCX FLTCOND expert.

Several extensions have been made to Program CC Version 3 as part of this project. A command called "SIGGY" has been added to generate Bode-siggy root locus plots. The SFREQ command has been added to perform singular value based robustness calculations for multi-input multi-output problems. These additional commands are documented in Ref. 2. Some additional extensions have been made to Program CC to facilitate the interface with LEVEL5. LEVEL5 has special features for passing data to and from programs in several languages, but not BASIC in which Program CC is written. Thus some auxiliary programs have been written to pass data by reading files generated by LEVEL5 and converting them to Program CC compatible format and vice versa. This allows LEVEL5 to transmit not only numerical data but also Program CC macro names.

An advanced version, Version 4, of Program CC is now being marketed by STI (Ref. 3 and 4). Version 4 has all of the capabilities of Version 3 including Bode-siggy root locus and singular value robustness methods but

with many improvements in these plus many new methods and commands. Version 4 also has a command line feature that streamlines interfacing with other software such as LEVEL5. Unfortunately, the RAM memory requirements are sufficiently higher for this advanced version so that it can not be used with LEVEL5. This is due to the intrinsically high memory requirements of LEVEL5. However the capabilities of Program CC Version 3 are more than adequate to support the present level of development of FCX.

#### D. STRUCTURE OF THE FCX EXPERT SYSTEM

The FCX flight control design expert system is a collection of 18 chained LEVEL5 knowledge bases which act as group of "consulting experts". Each expert has knowledge of a quite limited area of flight control design such as definition of requirements for the given aircraft and flight condition or yaw damper design. While these software experts mimic the capability of expert human FCS designers, they are much more limited in their scope (and certainly their capability and knowledge) than a human design expert.

The division of responsibility among the experts is logically related to the design procedures of Sec I through IV, but the actual scope of each knowledge base is determined primarily by software design considerations. Primary among these software considerations is the need to minimize the difficulty of testing and validation by limiting the size of each chained knowledge base. This consideration is analogous to the accepted practice of using small modular subroutines in structured programming in procedural languages. However, the expert system environment has some inherent features which make it easier to test individual experts in isolation. Testing subroutines in isolation often requires time-consuming development of special files or loading programs. However any of the experts developed in LEVEL5 can be interrogated in isolation and, when facts that would ordinarily be provided by another knowledge base are required, the expert simply formulates an appropriately phrased question to the user.

## E. GLOBAL DATA STRUCTURES

Before the individual FCX knowledge bases are discussed, some global data structures that are used in common by all knowledge bases will be explained. These appear as a special type of LEVEL5 file called an "include" file. Include files are used to incorporate the same data elements in several chained knowledge bases without having to include redundant text in many PRL (ASCII knowledge base) files. An include file is included in a LEVEL5 knowledge base during compilation whenever the file name (preceded by a"\$") is encountered in the .PRL file.

### a. Shared Facts File

Whenever facts are to be used in more than one LEVEL5 chained knowledge base, they must be declared as "shared" facts in each knowledge base. This declaration takes the form of a list of the facts specifying the fact type (simplefact, numeric, attribute-value or string) of each. This shared facts list is analogous to common blocks used in FORTRAN programs and, like common blocks, it is essential that the shared facts list be exactly the same in each knowledge base. This is routinely handled in LEVEL5 by making the shared facts list an include file with the name SHAREFCT.SHR.

Strictly speaking not all facts need to be included in the shared facts list. However, it became apparent early in the development of FCX that it was very advantageous to include all facts in the list along with comments indicating the modules in which the facts were originally defined. This list grew very rapidly and became a focal point of development of FCX. In effect the shared facts list becomes the vocabulary of FCX and teaching the expert system an adequate vocabulary of flight control system design became one of the most time consuming and important parts of the development. This concern with the vocabulary of FCS design and the syntax of facts (and syntactical limitations in LEVEL5) are distinguishing characteristics of the expert system development compared to traditional algorithmic CACSD software in procedural languages. Specifically there is more concern with grammar (including vocabulary, syntax and semantics) in the former as opposed to a concern with variables, equations

and algorithms in the latter. In retrospect, this seems reasonable for a software environment (the expert system) which attempts to deal with those heuristics which have traditionally been easier to state qualitatively in English than quantitatively in mathematical expressions. This implies a more practical role for natural-language interfaces in CACSD software than was earlier realized. In particular as noted above the important role that FCX can play for the journeyman FCS designer, apart from providing FCS design recommendations, is to interface with the algorithmic software (i.e., Program CC) in the language of aircraft dynamics and flight control systems rather than the generic command language of Program CC.

b. Multi-Valued Attributes File

Attribute-value fact types are the most complex syntactical forms in LEVEL5 and are useful in reducing the number of questions the user must be asked to establish a fact. Ordinarily this comes about because LEVEL5 assumes that an attribute has only one true value. For example if the "Aircraft Classification" attribute is known to have the value "Class IV" the user does not have to be asked if the value is Class I, II or III because FCX knows these are mutually exclusive values. This makes the expert system appear more intelligent at a common sense level. However, it is quite possible for certain attributes to have more than one value simultaneously. For example the "Yaw damper measurement" attribute can include both yaw rate and roll rate. This is provided for in LEVEL5 by using the MULTI control element selector. To insure that all knowledge bases treat attribute-value pairs the same, the MULTI declaration is included in each PRL knowledge base file. For convenience and consistency the MULTI declaration has been placed in an include file called MULTI.SHR.

c. Exhaustive Evaluation of Simplefacts

LEVEL5 provides a control element selector for simplefacts, called EXHAUSTIVE, which is analogous to the MULTI selector for attribute-value pairs. Enabling the EXHAUSTIVE control element causes the inference engine to evaluate all possible rules which can conclude a fact rather than stopping when the fact has been verified. Many simplefacts state

that a certain action has been taken and are often placed in goal outlines to drive the design and assessment processes. Practical experience has shown that it is necessary to evaluate many of these simplefacts exhaustively to keep FCX from "stalling". The EXHAUSTIVE declarations are made global over FCX by listing them in an include file named EXHAUSTV.SHR.

## **F. FCX KNOWLEDGE BASES**

The structure of the FCX Flight Control Design Expert System is shown in the Fig. 1 diagram of the relationship of the 18 chained knowledge bases. Each knowledge base and its interaction with the other knowledge bases is discussed in turn in the following sections. Complete listings of the knowledge bases and related files are provided at the end of this Supplement.

### **1. GENERATE**

The GENERATE knowledge base serves as the point of first contact with the user and acts as the intermediary between the user and the other FCX experts. The FCX expert system is started by running the GENERATE knowledge base. One of the first activities performed automatically by GENERATE is to initialize certain simplefacts and attribute values as false using INIT statements. When a design session begins, GENERATE presents the user with the menu in Fig. 2 to identify, at the highest level, what he or she wishes to do.

The first menu option allows the user to initiate specification of a new aircraft for which an FCS is to be designed. When this option is exercised, the AIRCRAFT expert is called to obtain all aircraft data independent of flight condition.

The second option allows the user to specify a new flight condition for a previously specified aircraft. Selection of this option calls the FLTCOND expert for collection of all data dependent on flight condition such as trim values and stability derivatives.

When all aircraft and flight condition data has been obtained using the first two options, actual FCS design may be initiated by picking the third option to select a FCS architecture to be pursued. The ARCH expert

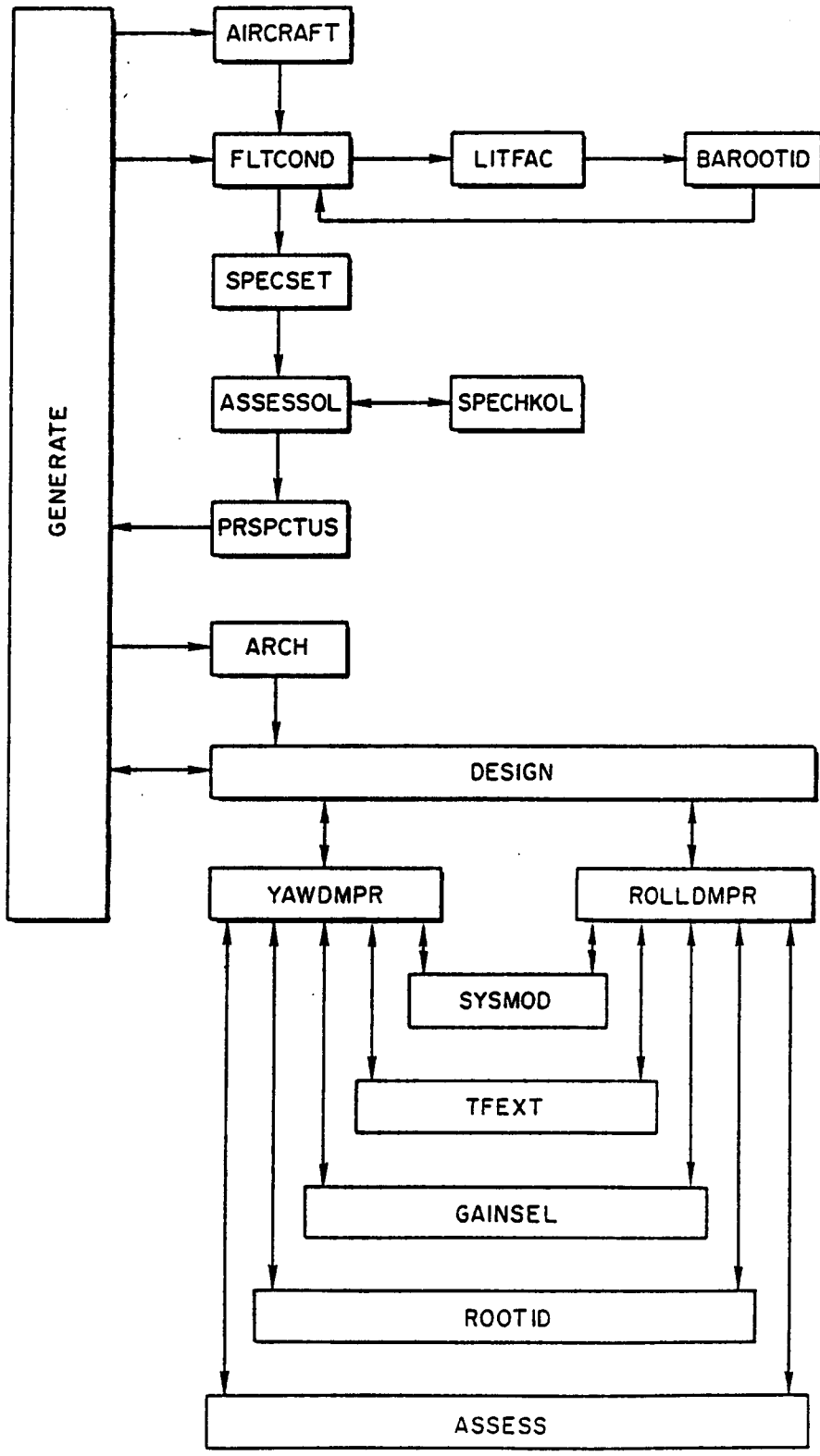

Figure 1. Knowledge Base Structure in the FCX Flight Control Expert System

|  |
|--|
| Specify a new aircraft for FCS design                    |
| Specify a new flight condition for the current aircraft  |
| Select an FCS architecture for design                    |
| Select a loop for design within the current architecture |
| Store current design data on file                        |

Figure 2. FCX Main Menu

will then be invoked to select the current architecture from the candidate architectures selected previously by the PRSPCTUS expert (discussed further below.

An FCS feedback loop can be selected directly for design using the fifth option which invokes the DESIGN expert. This would ordinarily be done during iteration on a loop design.

The last option allows the user to store all facts and data from the current design session on disk (the C drive, subdirectory FCSDAT) in the file LASTDSGN.CTX.

The five options in the initial menu are implemented in GENERATE as the five top level items in the goal outline structure.

**2. AIRCRAFT**

The AIRCRAFT expert handles definition of the aircraft for which the FCS is to be designed and functions primarily as a natural language interface at present. This includes collection of configuration parameters which are independent of flight condition such as geometry and mass properties. When this expert is invoked any previous aircraft data will be discarded, thus if the user desires to retain previous information it should be stored on file using the last option in GENERATE. AIRCRAFT first queries the user for a designation for the aircraft which is any name or one line phrase which the user specifies. AIRCRAFT next queries

for the classification (per MIL-F-8785) of the aircraft and the degrees of freedom for which control is to be exercised by the FCS. Presently expert assistance is available only for the lateral-directional DOF. When this preliminary data has been obtained, AIRCRAFT obtains the basic aircraft geometry and mass properties parameters by reading the aircraft basic data file (C:\FCSDAT\ACDATA.PRM). This ASCII file is written in the format required by the LEVEL5 READ function and contains the parameter listed in Fig. 3.

This data is later used in the definition of the rigid body dynamics. The "high frequency" dynamics of other components and structural dynamics are presently assumed independent of flight condition and are thus established under the aegis the AIRCRAFT expert. Further development of FCX would, at some point, account for the variation of the high frequency dynamics with flight condition (e.g., through the impact of surface hinge moment on actuator bandwidth available). At that time management of this activity would be given to the FLTCOND expert discussed next.

|                         |                         |
|-------------------------|-------------------------|
| Aircraft Kind           | (Text Phrase)           |
| Aircraft Class          | (Roman Numeral)         |
| Planform Area           | (ft <sup>2</sup> )      |
| Mean Aerodynamic Cord   | (ft)                    |
| Wing Span               | (ft)                    |
| Thrust Inclination      | (deg)                   |
| Weight                  | (lbs)                   |
| X Center of Gravity Mac | (%)                     |
| X Center of Gravity     | (ft)                    |
| Y Center of Gravity     | (ft)                    |
| Z Center of Gravity     | (ft)                    |
| X Moment of Inertia     | (slug-ft <sup>2</sup> ) |
| Y Moment of Inertia     | (slug-ft <sup>2</sup> ) |
| Z Moment of Inertia     | (slug-ft <sup>2</sup> ) |
| XY Product of Inertia   | (slug-ft <sup>2</sup> ) |
| XZ Product of Inertia   | (slug-ft <sup>2</sup> ) |
| YZ Product of Inertia   | (slug-ft <sup>2</sup> ) |

Figure 3. Aircraft Basic Data File,  
"ACDATA.PRM"



At present the surface actuators, rudder and aileron (generic roll control), are modeled with first order lags specified by bandwidths obtained from the user. This data is transmitted to Program CC through the PROCALL interface which executes the "ACTUATOR" macro in Program CC. This macro generates the appropriate actuator transfer function models setting the inverse time constant to the user-specified bandwidth and stores them on file.

The remaining high frequency dynamics in each surface channel are lumped as an effective time delay modeled with a second order Pade' approximation. The user is queried for the effective time delay in seconds for each channel. This number accounts for all components in the respective channel other than the actuator and rigid body dynamics, i.e. structural modes, bending and smoothing filters, digital computer cycle time, sensor lag, etc. This data is transmitted to Program CC through the PROCALL interface which executes the "TIMEDEL" macro in Program CC. This macro generates the appropriate second order Pade' transfer function models of the effective time delays and stores them on file.

Once the basic flight-condition-independent aircraft data has been obtained, a flight condition must be established and AIRCRAFT calls up the FLTCOND expert for this activity.

### 3. FLTCOND

The FLTCOND expert establishes the flight condition parameters, such as speed, altitude and the trim values of all relevant state variables. It also obtains all other parameters needed to define the aircraft which are functions of flight condition, in particular the stability and control derivatives. FLTCOND is either invoked by the AIRCRAFT expert when a new aircraft is defined or it is called up by GENERATE when the user chooses the second, "Select a new flight condition ..." option in GENERATE. In either event, FLTCOND first obtains the flight condition and trim state variables from the file "C:\FCSDAT\FLTCOND.PRM". The parameters of this file are listed in Fig. 4.

|                               |                 |
|-------------------------------|-----------------|
| Flight Condition              | (Text phrase)   |
| Flight Phase                  | (Text phrase)   |
| Flight Phase Category Literal | (Mil-Spec code) |
| Mach Number                   |                 |
| Altitude                      | (ft)            |
| True Airspeed                 | (fps)           |
| Wing Span                     | (ft)            |
| Trim Angle of Attack          | (deg)           |
| Trim Angle of Sideslip        | (deg)           |
| Trim Heading                  | (deg)           |
| Trim Pitch Attitude           | (deg)           |
| Trim Bank Angle               | (deg)           |
| Trim Flight Path Angle        | (deg)           |
| Trim Roll Rate                | (deg/sec)       |
| Trim Pitch Rate               | (deg/sec)       |
| Trim Yaw Rate                 | (deg/sec)       |
| Trim Turn Rate                | (deg/sec)       |
| Trim Normal Load Factor       | (g's)           |
| Trim Lateral Load Factor      | (g's)           |
| Trim Axial Load Factor        | (g's)           |

Figure 4. Flight Condition and Trim File,  
"FLTCOND.PRM"

FLTCOND displays the flight condition parameters on the screen and then proceeds to read the stability and control derivatives from the file C:\FCSDAT\DERIVS.PRM. This file contains both the stability axis and the body (fuselage reference line) derivatives as listed in Fig. 5. The stability axis derivatives are listed first followed by the corresponding body axis derivatives (denoted with a "b" suffix).

When the above data has been obtained, FLTCOND proceeds to generate the "bare airframe" dynamics which consists of the rigid body equations of motion alone. The bare airframe dynamics are generated first to simplify identification of the aircraft poles and zeros without the added complexity of the actuator and high frequency dynamics. This is done by first computing the elements in the bare airframe state space matrices as defined on Fig. 6. Presently the Fig. 6 model used in FCX is restricted to level flight ( $\gamma_0 = 0$ ).

```

Yβ
Lβ'
Nβ'
Lp'
Np'
Lr'
Nr'
Yδa*
Lδa'
Nδa'
Yδr*
Lδr'
Nδr'
Yβb
Lβ'b
Nβ'b
Lp'b
Np'b
Lr'b
Nr'b
Yδa*b
Lδa'b
Nδa'b
Yδr*b
Lδr'b
Nδr'b

```

Figure 5. Stability and Control Derivatives File, DERIVS

The bare airframe state matrices are then stored in the file \$\$BAREAC.SSM which is converted to a Program CC state space quadruple via the DATOCC interface. The PROCALL interface is then called to generate the bare airframe dynamics in the form of a transfer function matrix by exercising the \$\$BAREAC macro in Program CC.

Once the bare aircraft dynamics have been generated, the corresponding literal approximate factors are generated by chaining to the LITFAC knowledge base which then chains to the BAROOTID expert to identify the bare airframe poles. When this is completed, control returns to FLTCOND. At this point definition of the aircraft and flight condition is complete, and the next step is definition of the specific requirements for the FCS design. This begins when FLTCOND calls the SPECSET expert.

$$\dot{x} = Ax + Bu$$

$$y = Cx + Du \quad \text{where}$$

$$x = (\beta, p_b, r_b, \phi_b)^T$$

$$y = (\beta, p_b, r_b, \phi_b, p_s, r_s)^T$$

$$u = (\delta_a, \delta_r)^T$$

$$\left[ \begin{array}{c|c} \frac{A}{C} & \frac{B}{D} \end{array} \right] = \left[ \begin{array}{cccc|cc} Y_v & \sin \alpha_o & -\cos \alpha_o & \frac{g \cos \theta_o}{V_{T_o}} & Y_{\delta_a}^* & Y_{\delta_r}^* \\ L'_{\beta} & L'_p & L'_r & 0 & L'_{\delta_a} & L'_{\delta_r} \\ N'_{\beta} & N'_p & N'_r & 0 & N'_{\delta_r} & N'_{\delta_r} \\ 0 & 1 & \tan \theta_o & 0 & 0 & 0 \\ \hline 1 & 0 & 0 & 0 & 0 & 0 \\ 0 & 1 & 0 & 0 & 0 & 0 \\ 0 & 0 & 1 & 0 & 0 & 0 \\ 0 & 0 & 0 & 1 & 0 & 0 \\ 0 & \cos \alpha_o & \sin \alpha_o & 0 & 0 & 0 \\ 0 & -\sin \alpha_o & \cos \alpha_o & 0 & 0 & 0 \end{array} \right]$$

Figure 6. Bare Airframe Model

#### 4. LITFAC

The LITFAC expert generates and evaluates the required literal approximate factors for poles and zeros of the bare airframe. The adjective "literal" is included in fact phrases such as "Literal roll spiral mode complexity IS real" to distinguish facts about literal approximate factors from corresponding facts about factors obtained by numerical factoring (in Program CC). For numeric facts represented by symbols, a "\$" is appended to denote a literal approximate factor. Thus "Wd\$" denotes the literal approximate dutch roll undamped natural frequency which corresponds to the numerically factored value denoted by "Wd".

LITFAC begins by evaluating the (absolute value of the) damping ratios of the roll-spiral and dutch roll modes using standard literal factors. These values are used by rules which determine the "complexity" (i.e., whether the roots are real or complex) of the two basic modes (roll-spiral and dutch roll). Additional rules then enumerate the real and/or complex poles based on mode complexity. The literal approximate pole parameters are then calculated (for the standard case -- real roll and spiral modes and complex dutch roll -- at present).

When the literal factors are available, LITFAC immediately calls BAROOTID.

#### 5. BAROOTID

The bare airframe poles are identified by the BAROOTID expert. This activity involves associating the bare airframe eigenvalues with the traditional physical mode names for aircraft lateral-directional dynamics-- i.e., dutch roll, spiral and roll subsidence. These physical associations are essential to the design process implemented in FCX. For instance application of the flying qualities specifications requires not only the numerical eigenvalues but a knowledge of which are the dutch roll poles as well. Computer programs for eigenvalue calculations have been in routine use in flight control system design for many years, however identification of the physical modes has always been the job of the human analyst. A distinguishing characteristic of FCX is that it "comprehends" the physical associations of the modes and can in fact assist the user in making them.

At present the knowledge base for pole identification in BAROOTID is based on comparison of the literal (from LITFAC) and numerical (from Program CC) factors. Additional rules have been formulated for pole identification which would involve more active participation by the user and would provide more robust capability for unusual configurations (e.g., oblique wing aircraft) (Ref. 8). The interaction with Program CC to support these rules is more complex and thus they are not yet in BAROOTID.

BAROOTID begins by accessing the numerical bare airframe pole parameters from Program CC. This is done by exercising the program TFCCL5 which converts a Program CC file to a special format in the file GFCX (Fig. 7). The GFCX file contains the poles and zeros sorted in order of increasing frequency. Thus the NUMERIC fact "inverse time constant of real pole #2" is associated with the real pole with the second lowest frequency. This would generally be expected to be the roll subsidence pole, but it might be a real dutch roll pole with, say, high AOA-induced loss of directional stability. The GFCX file also contains the number of real and complex poles and zeros.

After the bare airframe pole parameters are identified, the number of real and complex poles are checked to verify that a physically possible configuration exists. If so, a validity check is made on the literal approximate factors by comparing the number of literal real roots to the number of numerical real roots. If these are equal, the physical pole designation are assigned to the numerical pole closest to the corresponding literal pole. A final validity check of the literal factors is made by computing the separation between the literal and numerical parameters. A tolerance of about 20% is considered acceptable and if this is achieved control is returned to the FLTCOND expert system.

## 6. SPECSET

The SPECSET expert sets up the requirements and specifications for the given aircraft and flight condition. For those requirements derived from the military flying qualities specifications, the basic factors are the aircraft class and flight phase category. At present only a portion of the relevant requirements for Class IV (highly maneuverable) aircraft in Category CO (air-to-air combat) operation are included in FCX.

Number of numerical real zeros  
 Number of numerical complex zero pairs  
 Number of numerical real poles  
 Number of numerical complex pole pairs  
 Number of nonminimum phase numerical real zeros  
 Number of nonminimum phase numerical complex zero pairs  
 Number of unstable numerical real poles  
 Number of unstable numerical complex pole pairs  
 High frequency gain  
 Inverse time constant of real zero #1  
 Inverse time constant of real zero #2  
 Inverse time constant of real zero #3  
 Inverse time constant of real zero #4  
 Inverse time constant of real zero #5  
 Inverse time constant of real zero #6  
 Damping ratio of complex zero pair #1  
 Natural frequency of complex zero pair #1  
 Damping ratio of complex zero pair #2  
 natural frequency of complex zero pair #2  
 Damping ratio of complex zero pair #3  
 natural frequency of complex zero pair #3  
 Damping ratio of complex zero pair #4  
 natural frequency of complex zero pair #4  
 Damping ratio of complex zero pair #5  
 natural frequency of complex zero pair #5  
 Damping ratio of complex zero pair #6  
 natural frequency of complex zero pair #6  
 Inverse time constant of real pole #1  
 Inverse time constant of real pole #2  
 Inverse time constant of real pole #3  
 Inverse time constant of real pole #4  
 Inverse time constant of real pole #5  
 Inverse time constant of real pole #6  
 Damping ratio of complex pole pair #1  
 natural frequency of complex pole pair #1  
 Damping ratio of complex pole pair #2  
 natural frequency of complex pole pair #2  
 Damping ratio of complex pole pair #3  
 natural frequency of complex pole pair #3  
 Damping ratio of complex pole pair #4  
 natural frequency of complex pole pair #4  
 Damping ratio of complex pole pair #5  
 natural frequency of complex pole pair #5  
 Damping ratio of complex pole pair #6  
 natural frequency of complex pole pair #6

Figure 7. Transfer Function File for Input to LEVEL5, GFCX

The requirements are first set for each mode. When all modal requirements are set, the requirement set is considered complete (for the present capability of FCX) and the ASSESSOL expert is called to begin assessment of the unaugmented aircraft dynamics.

## 7. ASSESSOL

The ASSESSOL expert performs various setup operations so that the bare airframe dynamics can be assessed. This assessment of the bare airframe dynamics provides the basis for the prospectus for control. The first job performed by ASSESSOL is formulation of the open loop aircraft model (Fig. 8) which consists of the bare airframe (rigid body) plus actuator plus effective time delay high frequency dynamics models previously created. The PROCALL interface is activated to run the OLAIPLN macro in Program CC. This macro performs STATE command operations culminating in the transfer function matrix for the open loop aircraft.

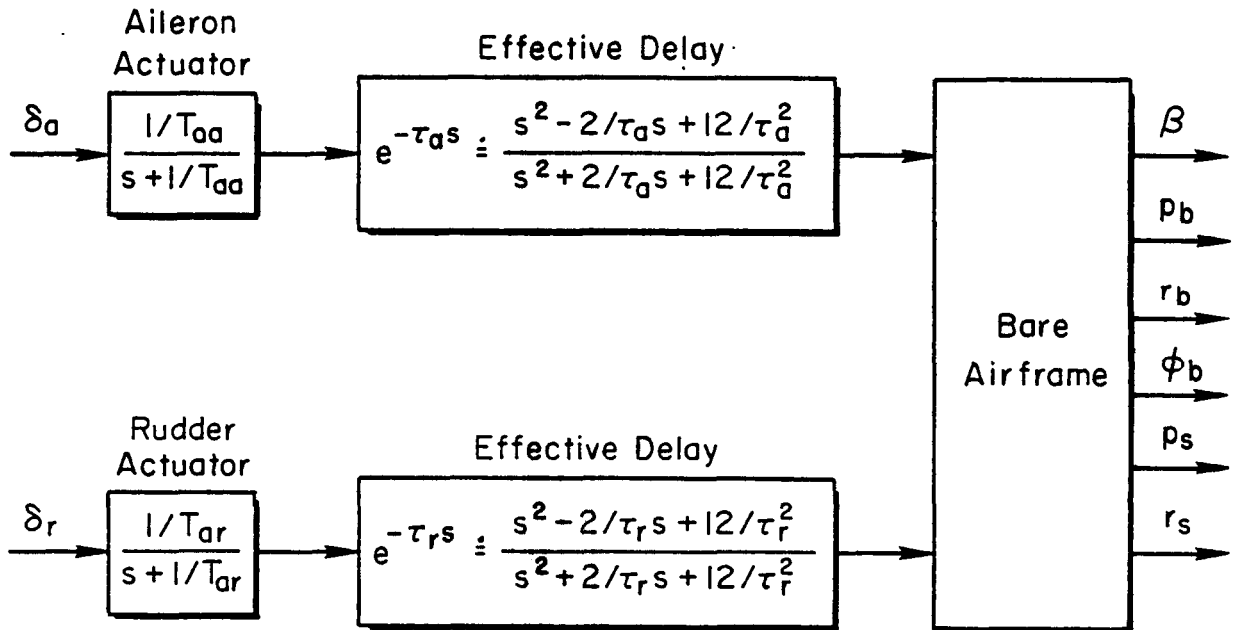

Figure 8. Open Loop Aircraft



When the poles and zeros have been identified, the requirements can be applied to assess the open loop dynamics. This is done by invoking the SPECHKOL expert which performs the detailed assessments. When SPECHKOL is finished, control is returned to ASSESSOL which calls the PRSPCTUS expert to define the prospectus for control based on the detailed open loop aircraft assessment. When PRSPCTUS is finished, control is again returned to ASSESSOL which immediately returns control to GENERATE. At that point the user is presented with the GENERATE main menu and would typically select the third option -- "Select an FCS architecture for design".

#### 8. SPECHKOL

The SPECHKOL expert performs the actual numerical comparison of the bare airframe dynamics, as established in ASSESSOL, with the specialized requirements generated in SPECSET. The requirement comparisons are first made for each mode and then the overall assessment of the open loop dynamics is made based on the modal assessments. The rule for adequate open loop dynamics, at the present state of development of FCX, is that the dutch roll and roll subsidence modal dynamics are adequate. When this open loop assessment is completed, control is returned to ASSESSOL.

#### 9. PRSPCTUS

The prospectus for control is established with the PRSPCTUS expert. PRSPCTUS first establishes the candidate feedback loops that might be useful in correcting the unaugmented aircraft deficiencies identified previously. Possibly useful loops are collected at this point without regard to redundancy of purpose. Next subsets of candidate loops are collected into candidate architectures. This eliminates some of the original redundancy by using rules that develop generally minimal loop structures that can be expected to provide an adequate basis for an FCS design. The candidate architectures represent the nuclei of complete FCS designs and provide the context for the detail design steps to follow. Next PRSPCTUS establishes a recommended order in which the candidate designs should be investigated to increase the chances that the most promising designs will be pursued first.

When the prospectus for control, in the form of candidate loops and ranked candidate architectures, is established, the control is transferred to the GENERATE expert. At this point the user would ordinarily exercise the third option in the GENERATE main menu, "Select an FCS architecture for design", to initiate FCS design. This option directly invokes the ARCH expert.

#### 10. ARCH

The ARCH expert manages the actual selection of the "current architecture" -- the architecture for which a design is presently being pursued. This selection depends on which, if any, architectures have previously been pursued. Once the current architecture has been selected, ARCH sets a recommended order in which the loops should be closed in the design sequence. When this has been done, ARCH calls the DESIGN expert to manage the actual design process for the current architecture.

#### 11. DESIGN

Once the current architecture is defined, control passes to the DESIGN expert which manages the actual detail design process. The first activity is the selection of the "current loop" -- the loop, within the current architecture, which is presently being designed. This selection depends on which loops, if any, have previously been designed for the current architecture. Next, the current loop connections are defined; that is, each loop in the current architecture is identified as being open or closed.

Once the current loop connections are defined DESIGN assigns the design of the current loop to a specialist. At present there are two specialists available: YAWDMPR which assists in the design of yaw damper loops and ROLLDMPR which assists in the design roll damper loops. Whenever one of the loop design experts completes a design iteration of the current loop, control is returned to DESIGN which determines whether a successful design has been found for the current architecture. When this occurs control is returned to GENERATE.

## 12. YAWDMPR

The YAWDMPR expert assists in the design of yaw damper loops when requested by the DESIGN expert. The user is first presented with a 3 item menu:

- Perform complete yaw damper design
- Define yaw damper feedback equalization
- Define yaw damper gain

If no previous design exists, the first option would be selected. YAWDMPR then begins by assisting the user in selection of the measurements to be used. A knowledgeable user can pick the desired measurements from a displayed list (with two entries -- roll rate and yaw rate). FCX monitors the selection and informs the user of an impractical selection (i.e. roll rate only). In this role YAWDMPR is assisting rather than consulting, however, the user can indicate that he doesn't know what measurements should be used. FCX will then attempt to use heuristics in the YAWDMPR knowledge base to recommend measurements. This may trigger additional queries to the user about the aircraft and its operation (i.e. whether or not it operates at high AOA). Basically YAWDMPR will attempt to determine if the angle of attack range is sufficiently restricted to allow the possibility of a single, properly tilted rate gyro or whether individual yaw and roll rate measurements are needed.

When the necessary measurements have been defined, YAWDMPR will query the user for roll and yaw rate measurement blending coefficients (Fig. 9) for a two measurement design or for gyro tilt angle for a single sensor design. Again the knowledgeable user can directly specify his selection when queried or reply "unknown". In the later case, YAWDMPR will attempt to make recommendations based on knowledge in the rules. For a two measurement design, YAWDMPR will recommend a "stability axis" yaw damper and define the blending coefficients accordingly. This will require knowledge of the trim angle of attack which should have been obtained by the FLTCOND expert. If this is not available YAWDMPR will query the user for the value.

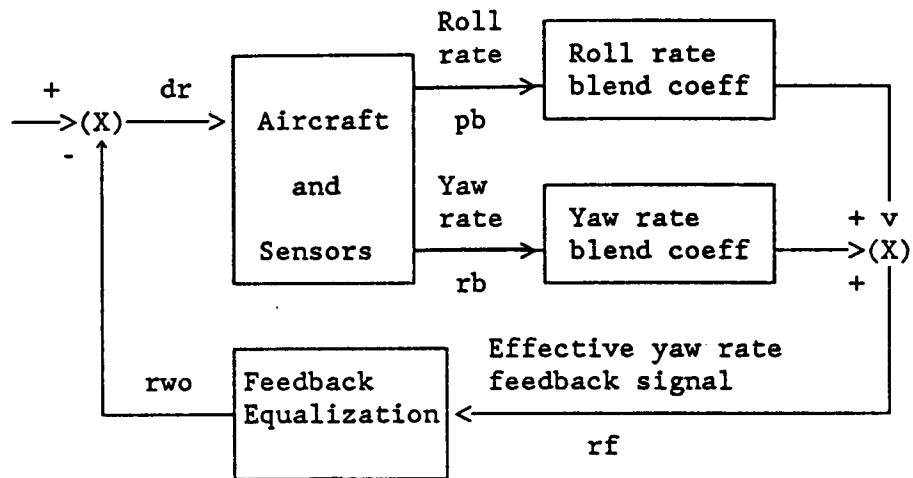

Figure 9. Yaw Damper Diagram Showing Roll and Yaw Rate Blending Coefficients

Once the blending coefficients or gyro tilt have been defined, an effective yaw rate signal (denoted  $r_f$ ) will have been defined and YAWDMPR invokes the SYSMOD, TFEXT and ROOTID experts to generate the effective open loop  $r_f/\delta_r$  transfer function (Fig. 10). YAWDMPR will then attempt to determine if the effective yaw rate is "suitable", i.e., whether or not the complex yaw rate zero is sufficiently well separated from the dutch roll pole to make a good yaw damper. If YAWDMPR has taken the lead in defining the measurements, the stability axis damper design will probably be adequate based on experience. YAWDMPR will query the user about the effective  $\omega_r/\omega_d$  dipole separation.

When a suitable effective feedback signal is defined, YAWDMPR manages the definition of the feedback equalization. The form of the equalization -- a washout filter -- is part of the knowledge base. The user is queried for a value of the washout time constant, but if this is unknown by the user YAWDMPR will pick a value. Initially YAWDMPR will place the washout about an octave below the dutch roll. If this ultimately does not lead to a successful design, YAWDMPR contains additional rules for adjusting the washout which will come into play when the design is "cycled" for another iteration.

Once the washout time constant is set, YAWDMPR will again invoke SYSMOD, TFEXT and ROOTID to generate the open loop  $\delta_{rf}/\delta_r$  transfer function (Fig. 10). When this has been done, the last design step is selection of the gain. For a properly equalized open loop transfer function, this step is generic and YAWDMPR consults with GAINSEL to do the job. Once the loop gain is selected, the current yaw damper design is complete and must be assessed. In preparation for this, YAWDMPR again involves SYSMOD, TFEXT, and ROOTID to obtain the closed loop system dynamics.

Next YAWDMPR invokes the ASSESS expert to assess the design against the appropriate requirements. If design assessment indicates that the relevant characteristic (i.e., dutch roll damping) is adequate, YAWDMPR pronounces the yaw damper design satisfactory and turns the job over to DESIGN. If the dutch roll damping is not satisfactory, YAWDMPR "cycles" to begin another iteration of the yaw damper design. In that case the 3 option first level menu will appear so the user can change the washout, the gain, or start all over again.

### 13. ROLLDMPR

The ROLLDMPR expert assists in the design of roll dampers when requested by the DESIGN expert. ROLLDMPR uses a body axis roll rate measurement and assists the user in defining the feedback equalization and loop gain. When ROLLDMPR is invoked it first asks the user if he wishes to define the equalization or the loop gain. If no previous design is available, the equalization must be set first and SYSMOD, TFEXT and ROOTID are invoked to generate the open loop  $p_b/\delta_a$  transfer function. The equalization form is limited to a first order lead-lag filter which can take the form of a pure gain. The user can directly specify that the filter time constants and loop gain or request assistance from ROLLDMPR in making the selection. When the user is uncertain about equalization, ROLLDMPR interacts with Program CC to generate a pure gain root locus and will assist in examining the locus topology to determine the required equalization form. ROLLDMPR will ultimately set a lead time constant if required and select a lag that can be expected to be adequate.

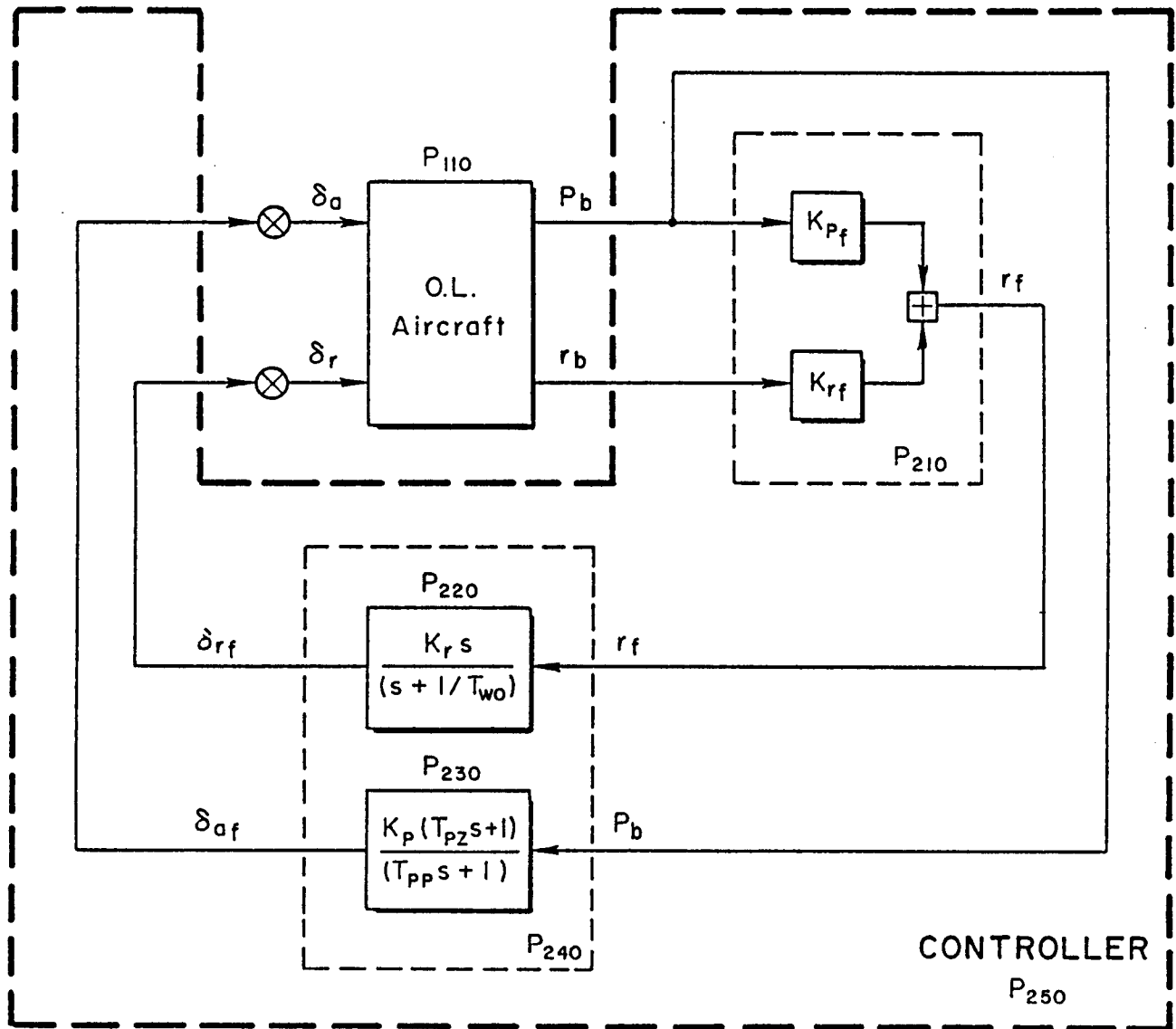

Figure 10. Augmented Aircraft System Model

Once the equalization is set, ROLLDMPR will again call SYSMOD, TFEXT and ROOTID to generate the open loop  $\delta_{af}/\delta_a$  transfer function (Fig. 10). When this has been done, GAINSEL is invoked to set the loop gain. ROLLDMPR then invokes SYSMOD, TFEXT and ROOTID once more to generate the current closed loop dynamics which generally will also include the current yaw damper loop. When this is completed ROLLDMPR calls on ASSESS to assess the roll damper design. If design assessment indicates that the relevant characteristic (i.e., roll subsidence mode time constant) is adequate, ROLLDMPR pronounces the design satisfactory and turns the job over to DESIGN. Otherwise, ROLLDMPR "cycles" to iterate the roll damper design.

#### 14. GAINSEL

The GAINSEL expert assists in the closure, i.e., the selection of the loop gain, for any loop once the nominal equalization has been established by one of the loop design specialists. The specialists (e.g., YAWDMPR) use heuristics to home in on likely equalization forms quickly, but gain selection for a properly equalized open loop transfer function is a more standardized operation. Thus this single expert handles closures of all loops. When GAINSEL is called, the user is presented with a four item menu. The first three options provide alternative procedures for setting the gain and the fourth terminates gain selection and returns to the loop design specialist which called GAINSEL.

The first option allows the user to enter a gain value immediately. The second and third options assist the user in using conventional and Bode root locus techniques respectively to set the gain. In the second and third options GAINSEL manages the interaction with Program CC to generate the desired root locus on screen.

#### 15. SYSMOD

The SYSMOD expert handles the generation of the closed loop model for the aircraft plus flight control system. For each architecture (presently only one -- yaw damper plus roll damper) a generic structure for the closed loop system is captured through LEVEL5 rules and Program CC macros

and data structures. Figure 10 shows the generic structure for the yaw damper plus roll damper architecture. The symbols consisting of a "P" with a numeric subscript are the Program CC identifiers for specific state space quadruples. Corresponding transfer function matrices and transfer functions are denoted by replacing the P's with "H" or "G" respectively.

When SYSMOD is called it generates the numerical values of the basic state quadruples in Figure 10 (using the current values of gains and time constants) and stores them on file in LEVEL5 format. The DATOCC program is then activated to convert these to state quadruple files in Program CC format ("\$\$P" files). The "FCSMODEL" Program CC macro is then initiated to generate the "closed loop" system transfer function matrix, P260 (whether the loops are really closed or not depends on the values of the loop gains.) Specific transfer functions needed in the analysis are also extracted from the system transfer function matrix and stored on file (as Program CC "\$\$G" files.) When the closed loop system dynamics have been defined, control is returned to the calling expert.

#### 16. TFEXT

The TFEXT expert performs the transfer of specified transfer functions, stored on disk as Program CC "\$\$G" files to LEVEL5 knowledge bases. The TTCCL5 program is activated to convert a file to LEVEL5 format stored in file TFTRANS.PRM. The file format is defined in Fig. 7. The TFTRANS file is then read into the TFEXT knowledge base and control is returned to the knowledge base which called TFEXT.

#### 17. ROOTID

The ROOTID expert identifies poles and zeros of the systems consisting of the aircraft plus partial or complete augmentation. This activity is analogous to that performed by BAROOTID and involves associating aircraft eigenvalues with the physical modes. However, ROOTID deals with more general augmented aircraft configurations and, in general, this is a much more complex problem. Rules based on the bare airframe literal approximate factors are not generally useful for this application, and closed loop approximate factors are not generally available (for an



example of approximate factors for "superaugmented" aircraft, see Ref. 9). This complication arises often in flight control analysis (e.g., it is central to problems in application of flying qualities specifications to lower order equivalent systems representing highly augmented aircraft, Ref. 10). Thus much more work is required to handle the general root identification process for FCX. The present development of ROOTID is quite elementary and restricted to the one architecture accommodated by FCX. The identification is performed by reference to several rules about the standard characteristics of the poles for the basic loop structures.

## 18. ASSESS

The ASSESS expert performs essentially the same assessment function as the SPECHKOL expert, but for the system with one or more FCS loops included instead of the open loop aircraft. The primary reason for having distinct SPECHKOL and ASSESS knowledge bases is limitations in the grammatical constructions of fact phrases in LEVEL5. These two modules could and probably should be combined in future developments. ASSESS compares the dynamics of the current assessment model to the specialized requirements set in SPECSET. When the requirement comparisons are completed, control is returned to the loop design expert which requested the assessment. The loop design expert then decides if the loop design is adequate based on the assessment of the relevant dynamic characteristics.

## G. UTILITY PROGRAMS

A number of utility programs written in compiled BASIC are used to interface LEVEL5 and Program CC.

### 1. DATOCC.EXE

File Type : Compiled BASIC program

Purpose : Converts files that are output by LEVEL5 into a form that Program CC can read.

Inputs :  
1. Directory where the LEVEL5 data file will be stored  
2. Name of the file LEVEL5 will create  
3. Directory where the Program CC file will be stored  
4. Name of the Program CC file that will be created

Description: Program CC uses a specific file format to save and recall the systems it needs. LEVEL5 also uses a specific file format to save and recall its data. These 2 file formats are not compatible, therefore a bridge program was written to convert LEVEL5 data files into a form that Program CC can use. DATOCC.EXE performs this conversion.

The program will look for the LEVEL5 data file in the given directory and then convert the contents of this file into Program CC form and save it in the subdirectory given, using the specified Program CC file name.

## 2. PROCALL.EXE

File Type : Compiled BASIC program

Purpose : Allows external programs to be executed from within LEVEL5.

Inputs : 1. Directory where the program to be executed is stored  
2. Name of the external program to be executed  
3. Instructions to be passed to the external program (macros, etc.)

Description: This module is used to call external programs from within LEVEL5. The advantage of this program over the LEVEL5 ACTIVATE command is that with this program you may pass parameters to the program you are calling, without having to modify the called program.

The program looks for the specified program in the specified directory and executes it. The user may pass parameters to the program if it is necessary.

## 3. TFCCL5.EXE

File Type : Compiled BASIC program

Purpose : Converts a Program CC transfer function file into a form that LEVEL5 may use.

Inputs : 1. Directory where the Program CC transfer function file is located  
2. Program CC transfer function file name  
3. File name and directory where the LEVEL5 compatible file will be stored

Description: This purpose takes a Program CC transfer function file and converts it into a form that LEVEL5 can use. It only works with Program CC transfer function files (i.e., \$\$Gi files). The LEVEL5 file can contain a maximum of 6 first order zeros, 6 second order zeros, 6 first order poles, and 6 second order poles.

The program searches the specified directory for the specified \$\$Gi file name and then creates the LEVEL5 compatible file and stores it using the specified name and subdirectory.

The LEVEL5 file has the following format:

Number of numerical real zeros  
Number of numerical complex zero pairs  
Number of numerical real poles  
Number of numerical complex pole pairs  
Number of nonminimum phase numerical real zeros  
Number of nonminimum phase numerical complex zero pairs  
Number of unstable numerical real poles  
Number of unstable numerical complex pole pairs  
High frequency gain  
Inverse time constant of real zero #1  
Inverse time constant of real zero #2  
Inverse time constant of real zero #3  
Inverse time constant of real zero #4  
Inverse time constant of real zero #5  
Inverse time constant of real zero #6  
Damping ratio of complex zero pair #1  
Natural frequency of complex zero pair #1  
Damping ratio of complex zero pair #2  
Natural frequency of complex zero pair #2  
Damping ratio of complex zero pair #3  
Natural frequency of complex zero pair #3  
Damping ratio of complex zero pair #4  
Natural frequency of complex zero pair #4  
Damping ratio of complex zero pair #5  
Natural frequency of complex zero pair #5  
Damping ratio of complex zero pair #6  
Natural frequency of complex zero pair #6  
Inverse time constant of real pole #1  
Inverse time constant of real pole #2  
Inverse time constant of real pole #3  
Inverse time constant of real pole #4  
Inverse time constant of real pole #5  
Inverse time constant of real pole #6  
Damping ratio of complex pole pair #1  
Natural frequency of complex pole pair #1  
Damping ratio of complex pole pair #2  
Natural frequency of complex pole pair #2  
Damping ratio of complex pole pair #3  
Natural frequency of complex pole pair #3  
Damping ratio of complex pole pair #4  
Natural frequency of complex pole pair #4  
Damping ratio of complex pole pair #5  
Natural frequency of complex pole pair #5  
Damping ratio of complex pole pair #6  
Natural frequency of complex pole pair #6

## H. PROGRAM CC MACROS

Program CC macros are ASCII text files containing sequences of Program CC commands to perform special operations initiated by the FCX knowledge bases.

### 1. BAREAC.MAC

File Type : Program CC macro file

Purpose : Creates a transfer function matrix from a state space quadruple

Inputs : 1. Program CC state space quadruple file name (\$\$Pi)  
2. Program CC transfer function matrix file name (\$\$Hi)

Description: This Program CC macro takes the specified state space quadruple and converts it to a transfer function matrix. The macro then displays the matrix, and returns to be the LEVEL5 knowledge base.

### 2. OLAIRPLN.MAC

File Type : Program CC macro file

Purpose : Creates the open loop aircraft lateral dynamics state space quadruple.

Inputs : None

Description: This Program CC macro creates the open loop airplane dynamics state space quadruple. Given the forward path (aileron actuator, \$\$G50; aileron delay, \$\$G60; rudder actuator \$\$G51; and rudder delay, \$\$G61) and the bare airframe dynamics (\$\$P100) the open loop airplane dynamics quadruple (\$\$P110) will be created. The macro first creates a feed forward block (\$\$P70) that contains the aileron and rudder dynamics, then it computes the state space quadruple, and finally it computes and displays the open loop transfer function matrix.

### 3. FORWARD.MAC

File Type : Program CC macro file

Purpose : Creates the open loop forward path for the lateral dynamics system.

Inputs : 1. Aileron actuator time constant  
2. Rudder actuator time constant  
3. Aileron effective time delay  
4. Rudder effective time delay

Description: This macro creates the forward loop paths for the lateral dynamics system. Given the aileron and rudder time constants and effective time delays, it creates the forward loop transfer functions. The aileron actuator is stored in \$\$G50, the rudder actuator is stored in \$\$G51, the aileron time delay is stored in \$\$G60, and the rudder time delay is stored in \$\$G61. The time delays are computed as second order Pade approximations.

#### 4. FCSSMODEL.MAC

File Type : Program CC macro file

Purpose : Generates the closed loop lateral dynamics transfer function matrix.

Inputs : None

Description: This Program CC macro creates the complete closed loop lateral dynamics transfer function matrix. In order for this macro to work correctly the user must first have created the open loop aircraft state space quadruple (\$\$P110, this includes the bare airframe quadruple and the forward path OLAIRPLN.MAC). This macro displays the yaw rate and roll rate feedback transfer functions, creates the feedback steady state quadruple, and finally creates and displays the closed loop transfer function matrix (\$\$H260)4.

#### 5. OLTFF.MAC

File Name : Program CC macro file

Purpose : Compute various open loop transfer functions for the lateral dynamics system.

Inputs : None

Description: This Program CC macro computes open loop transfer functions at various points in the lateral dynamics system. This allows the user to evaluate the system both open and closed loop. The open loop transfer functions that are calculated are:

|                      |            |
|----------------------|------------|
| $pb/\delta a$        | (\$G26012) |
| $rb/\delta r$        | (\$G26021) |
| $rf/\delta r$        | (\$G26031) |
| $\delta rf/\delta r$ | (\$G26041) |
| $\delta af/\delta a$ | (\$G26052) |

To evaluate the system open loop, you must set the feedback gains to zero. This means that  $K_r$  (yaw rate feedback gain) should be set to zero if you want to open the yaw rate feedback, and  $K_p$  (roll rate feedback gain) should be set to zero if you want to open the roll rate feedback. When looking at the open loop transfer functions for  $\delta rf/\delta r$  and  $\delta af/\delta a$  the gains ( $K_r$  and  $K_p$ ) are equal to 1 so that a suitable closed loop gain may be obtained.

## I. INSTALLATION OF THE FCX SOFTWARE

The FCX software is set up to be run from a hard disk (the C: drive) on an IBM PC-compatible computer under the DOS operating system. Four subdirectories are used: C:\FCSXPRT, C:\FCSDAT, C:\STI and C:\L5. The FCSXPRT subdirectory contains the FCX "include" files and knowledge bases both as .PRL files and as compiled .KNB files (Table 1). The FCSDAT subdirectory holds various data files created by FCX. Subdirectory C:\STI contains the utility programs and Program CC macros listed in Table 2 as well as the actual Program CC files. The LEVEL5 program is installed in subdirectory C:\L5.

## J. INITIATING A FCX SESSION

An FCX session is initiated by bringing up the LEVEL5 environment as explained in Ref. 1. When the first ("What would you like to do?") menu appears, select the first option -- "Run a knowledge base". When the "Run which knowledge base?" menu appears, press the F3 function key to change the default directory name. Enter "C:\FCSXPRT" when prompted for the directory name to change to. When the "Run which knowledge base?" menu reappears with the names of the 18 FCX knowledge bases, select "GENERATE".

When the GENERATE banner appears, press the F3 function key to continue and you will be asked whether the previous data should be restored. Ordinarily when starting a new design this will be false. After this decision the FCX main menu will appear. If a new aircraft is to be specified, the first option should be selected. Aircraft, flight condition and

TABLE 1. INCLUDE FILES AND KNOWLEDGE BASES IN C:\FCSXPRT

| NAME            | EXT. | SIZE(kb) |
|-----------------|------|----------|
| Include Files   |      |          |
| SHAREFCT        | SHR  | 30056    |
| INITATT         |      | 1074     |
| MULTI           | SHR  | 203      |
| EXHAUSTV        | SHR  | 8895     |
| Knowledge Bases |      |          |
| AIRCRAFT        | PRL  | 8952     |
| TFEXT           | PRL  | 10181    |
| FLTCOND         | PRL  | 10384    |
| ASSESSOL        | PRL  | 5598     |
| SPECSET         | PRL  | 3329     |
| PRSPCTUS        | PRL  | 5723     |
| ROLLDMPR        | PRL  | 15664    |
| ASSESS          | PRL  | 6551     |
| YAWDMPR         | PRL  | 33569    |
| GAINSEL         | PRL  | 3699     |
| DESIGN          | PRL  | 10070    |
| BAROOTID        | PRL  | 14872    |
| ARCH            | PRL  | 4134     |
| SYSMOD          | PRL  | 7056     |
| GENERATE        | PRL  | 7840     |
| SPECHKOL        | PRL  | 5203     |
| LITFAC          | PRL  | 4802     |
| ROOTID          | PRL  | 5127     |

TABLE 2. UTILITIES AND MACROS IN C:\STI

| NAME              | EXT. | SIZE(Kb) |                   |
|-------------------|------|----------|-------------------|
| Utility programs  |      |          |                   |
| DATOC             | EXE  | 14814    |                   |
| PROCALL           | EXE  | 12348    |                   |
| TFCCL5            | EXE  | 18364    |                   |
| BASRUN            | EXE  | 31744    | } Basic Libraries |
| BRUN40            | EXE  | 76816    |                   |
| Program CC macros |      |          |                   |
| FORWARD           | MAC  | 136      |                   |
| BAREAC            | MAC  | 42       |                   |
| FCSMODEL          | MAC  | 747      |                   |
| OLAIRPLN          | MAC  | 457      |                   |
| TIMDEL            | MAC  | 45       |                   |
| ACTUATOR          | MAC  | 47       |                   |
| OLTF              | MAC  | 760      |                   |
| BAPDA             | MAC  | 248      |                   |
| BODESIG           | MAC  | 55       |                   |
| ROOTLOC           | MAC  | 31       |                   |

stability derivative data files -- ASCII files ACDATA.PRM (Fig. 3), FLTCOND.PRM (Fig. 4) and DERIVS.PRM (Fig. 5) respectively -- must be available on subdirectory C:\FCSDAT. After the aircraft is defined, FCX will proceed to definition of the candidate architectures. When this has been done the main menu in GENERATE will appear. Ordinarily at this point the third option "Select an architecture for design" would be chosen to proceed with flight control design.



## REFERENCES

1. LEVEL5 User's Manual (PC Version), Expert System Software Information Builders, Inc., New York, NY, 1987.
2. Thompson, Peter M., Program CC Version 3 User's Guide, Systems Technology, Inc., Hawthorne, CA, May 1985.
3. Thompson, Peter M., Program CC Version 4 Tutorial and User's Guide, Systems Technology, Inc., Hawthorne, CA, May 1988.
4. Thompson, Peter M., Program CC Version 4 Reference Manual, Vols. I and II, Systems Technology, Inc., May 1988.
5. Winston, Patrick Henry, Artificial Intelligence, Addison-Wesley Publishing Company, Inc., USA and Canada, 1984.
6. Pang, G.K.H., J-M. Boyle, and A.G.J. MacFarlane, "An Expert System for Computer-Aided Linear Multivariable Control System Design," Proceedings of the IEEE Control Systems Society Third Symposium on Computer-Aided Control System Design (CACSD), Arlington, VA, Sept. 1986.
7. Munro, N., D.K. Frederick, and Z. Palaskas, "An Adaptive CACSD Dialogue Facility," Proceedings of the IEEE Control Systems Society Third Symposium on Computer-Aided Control System Design (CACSD), Arlington, VA, Sept. 1986.
8. Myers, Thomas T., Progress Report #13, Contract No. NAS1-17987, for the period 15 January through 1 June 1987, Systems Technology, Inc., June 1987.
9. Myers, T.T., D.T. McRuer, D.E. Johnston, Flying Qualities and Control System Characteristics for Superaugmented Aircraft, NASA CR-170419, Sept. 1984.
10. Hoh, Roger H., David G. Mitchell, Irving L. Ashkenas, et al., Proposed Mil Standard and Handbook -- Flying Qualities of Air Vehicles, Vol. I: Proposed MIL Standard, AFWAL-TR-82-3081(I), Nov. 1982.  
  
Hoh, Roger H., David G. Mitchell, Irving L. Ashkenas, et al., Proposed Mil Standard and Handbook -- Flying Qualities of Air Vehicles, Vol. II: Proposed MIL Handbook, AFWAL-TR-82-3081(II), Nov. 1982.

## **APPENDIX A**

# **FCX FLIGHT CONTROL DESIGN EXPERT SYSTEM KNOWLEDGE BASE LISTINGS**

**SHAREFCT.SHR**

```

! "SHAREFCT.SHR"
!
!   Shared Facts Declarations
!
!   The Shared Facts Declaration is stored in the "include" file named
!   "SHAREFCT.SHR"
!
! .....
!
!
!   Facts defined in GENERATE

```

```

SHARED NUMERIC g
! .....

```

```

! "AIRCRAFT.FCT"
!
!   AIRCRAFT DEFINITION   (AIRCRAFT)
!
!   Externally defined facts used in AIRCRAFT
!
!   Flight and trim conditions have been obtained
!   Stability and control derivatives have been obtained
!   Open loop aircraft dynamics have been obtained
!   Literal approximate factors have been obtained
!   Requirements must be set for the current case
!   Complete aircraft data has been obtained
!
!   Facts defined in AIRCRAFT

```

```

SHARED SIMPLEFACT Aircraft has been designated
AND SIMPLEFACT Aircraft has been classified
AND SIMPLEFACT Degrees of freedom for control have been defined
AND SIMPLEFACT aircraft basic data file has been read
AND SIMPLEFACT aileron actuator bandwidth has been specified
AND SIMPLEFACT rudder actuator bandwidth has been specified
AND SIMPLEFACT aileron channel effective time delay has been specified
AND SIMPLEFACT rudder channel effective time delay has been specified
AND SIMPLEFACT aileron actuator transfer function has been generated
AND SIMPLEFACT rudder actuator transfer function has been generated
AND SIMPLEFACT aileron time delay transfer function has been generated
AND SIMPLEFACT rudder time delay transfer function has been generated
AND SIMPLEFACT Actuator dynamics have been defined
AND SIMPLEFACT High frequency dynamics have been defined
AND SIMPLEFACT Aircraft basic data has been obtained
AND SIMPLEFACT Aircraft basic data must be obtained

```

```

SHARED ATTRIBUTE Aircraft classification IS Class I
AND ATTRIBUTE Aircraft classification IS Class II
AND ATTRIBUTE Aircraft classification IS Class III
AND ATTRIBUTE Aircraft classification IS Class IV
AND ATTRIBUTE aircraft type IS Fighter

```

AND ATTRIBUTE aircraft type IS Interceptor  
AND ATTRIBUTE aircraft type IS Attack  
AND ATTRIBUTE aircraft type IS Tactical reconnaissance  
AND ATTRIBUTE aircraft type IS Observation  
AND ATTRIBUTE aircraft type IS Trainer for Class IV aircraft  
AND ATTRIBUTE aircraft type IS generic high maneuverability aircraft  
AND ATTRIBUTE Degrees of freedom for control ARE lateral directional axes  
AND ATTRIBUTE Degrees of freedom for control ARE longitudinal axes

SHARED NUMERIC Planform Area

AND NUMERIC Mean Aerodynamic Cord  
AND NUMERIC Wing Span  
AND NUMERIC Thrust Inclination  
AND NUMERIC Weight  
AND NUMERIC X Center of Gravity Mac  
AND NUMERIC X Center of Gravity  
AND NUMERIC Y Center of Gravity  
AND NUMERIC Z Center of Gravity  
AND NUMERIC X Moment of Inertia  
AND NUMERIC Y Moment of Inertia  
AND NUMERIC Z Moment of Inertia  
AND NUMERIC XY Product of Inertia  
AND NUMERIC XZ Product of Inertia  
AND NUMERIC YZ Product of Inertia  
AND NUMERIC roll control actuator bandwidth  
AND NUMERIC rudder actuator bandwidth  
AND NUMERIC roll control channel effective time delay  
AND NUMERIC rudder channel effective time delay

SHARED STRING Aircraft Kind

AND STRING Aircraft Class  
AND STRING Aircraft designation

!.....

! "FLTCOND.PRL"

!

! FLIGHT CONDITION DEFINITION (FLTCOND)

! Externally defined facts used in FLTCOND

! Aircraft basic data has been obtained

! dutch roll damping ratio spec is set

! Requirements are set for the current case

! dutch roll damping ratio spec

! Facts defined in FLTCOND

SHARED SIMPLEFACT Flight and trim conditions have been obtained  
AND SIMPLEFACT Stability and control derivatives have been obtained  
AND SIMPLEFACT State matrix calculations have been obtained  
AND SIMPLEFACT Bare airframe dynamics have been obtained

AND SIMPLEFACT Literal approximate factors have been obtained  
AND SIMPLEFACT Complete aircraft data has been obtained  
AND SIMPLEFACT Requirements must be set for the current case

SHARED ATTRIBUTE Flight phase category IS Category CO

SHARED NUMERIC Mach Number  
AND NUMERIC Altitude  
AND NUMERIC True Airspeed  
AND NUMERIC Wing Span  
AND NUMERIC Trim Angle of Attack  
AND NUMERIC Trim Angle of Sideslip  
AND NUMERIC Trim Heading  
AND NUMERIC Trim Pitch Attitude  
AND NUMERIC Trim Bank Angle  
AND NUMERIC Trim Flight Path Angle  
AND NUMERIC Trim Roll Rate  
AND NUMERIC Trim Pitch Rate  
AND NUMERIC Trim Yaw Rate  
AND NUMERIC Trim Turn Rate  
AND NUMERIC Trim Normal Load Factor  
AND NUMERIC Trim Lateral Load Factor  
AND NUMERIC Trim Axial Load Factor  
AND NUMERIC  $Y\beta$   
AND NUMERIC  $L\beta'$   
AND NUMERIC  $N\beta'$   
AND NUMERIC  $Lp'$   
AND NUMERIC  $Np'$   
AND NUMERIC  $Lr'$   
AND NUMERIC  $Nr'$   
AND NUMERIC  $Y\delta a\#$   
AND NUMERIC  $L\delta a'$   
AND NUMERIC  $N\delta a'$   
AND NUMERIC  $Y\delta r\#$   
AND NUMERIC  $L\delta r'$   
AND NUMERIC  $N\delta r'$   
AND NUMERIC  $Y\beta b$   
AND NUMERIC  $L\beta'b$   
AND NUMERIC  $N\beta'b$   
AND NUMERIC  $Lp'b$   
AND NUMERIC  $Np'b$   
AND NUMERIC  $Lr'b$   
AND NUMERIC  $Nr'b$   
AND NUMERIC  $Y\delta a\#b$   
AND NUMERIC  $L\delta a'b$   
AND NUMERIC  $N\delta a'b$   
AND NUMERIC  $Y\delta r\#b$   
AND NUMERIC  $L\delta r'b$   
AND NUMERIC  $N\delta r'b$   
AND NUMERIC  $SIN\alpha o$   
AND NUMERIC  $NSIN\alpha o$   
AND NUMERIC  $COS\alpha o$

AND NUMERIC NCOS $\alpha_0$   
AND NUMERIC GCOS $\theta_0$   
AND NUMERIC TAN $\theta_0$   
AND NUMERIC ZERO  
AND NUMERIC ONE  
AND NUMERIC TWO  
AND NUMERIC FOUR  
AND NUMERIC SIX  
AND NUMERIC Yv  
AND NUMERIC  $\alpha_{orad}$   
AND NUMERIC  $\theta_{orad}$   
AND NUMERIC SIN $\alpha_0$   
AND NUMERIC NSIN $\alpha_0$   
AND NUMERIC COS $\alpha_0$   
AND NUMERIC NCOS $\alpha_0$   
AND NUMERIC GCOS $\theta_0$   
AND NUMERIC TAN $\theta_0$   
AND NUMERIC Uo

SHARED STRING Flight Condition

AND STRING Flight Phase  
AND STRING St1  
AND STRING St2  
AND STRING St7  
AND STRING St8  
AND STRING St9

!.....

!

! Bare Airframe Literal Approximate Factors (LITFAC)

SHARED SIMPLEFACT Bare airframe dynamics have been defined  
AND SIMPLEFACT Initial literal parameters have been calculated  
AND SIMPLEFACT Literal poles have been enumerated  
AND SIMPLEFACT Literal roll spiral coupling exists  
AND SIMPLEFACT Literal factors are defined for bare airframe poles  
AND SIMPLEFACT Literal factors are defined

SHARED ATTRIBUTE Literal roll spiral mode complexity IS complex  
AND ATTRIBUTE Literal roll spiral mode complexity IS real  
AND ATTRIBUTE Literal dutch roll mode complexity IS complex  
AND ATTRIBUTE Literal dutch roll mode complexity IS real

SHARED NUMERIC Wrs\$abs  
AND NUMERIC Wd\$abs  
AND NUMERIC ZWrs\$abs  
AND NUMERIC ZWd\$abs  
AND NUMERIC Zrs\$abs  
AND NUMERIC Zd\$abs  
AND NUMERIC Number of literal real poles  
AND NUMERIC Number of literal complex pole pairs  
AND NUMERIC ITr\$

AND NUMERIC ITs\$  
AND NUMERIC Wd\$  
AND NUMERIC ZWd\$  
AND NUMERIC Zd\$

!.....  
!  
! Bare Airframe Pole and Zero Identification (BAROOTID)  
!  
! Externally defined facts used in BAROOTID  
  
! Number of literal real poles  
  
! Facts defined in BAROOTID

SHARED SIMPLEFACT Generic bare airframe poles are defined  
AND SIMPLEFACT Bare airframe poles are identified  
AND SIMPLEFACT Literal factors are defined  
AND SIMPLEFACT Bare airframe identification transfer function has been read  
AND SIMPLEFACT Bare airframe real poles are feasible  
AND SIMPLEFACT Bare airframe complex poles are feasible  
AND SIMPLEFACT Bare airframe poles are feasible  
AND SIMPLEFACT Literal poles are valid at check #2  
AND SIMPLEFACT Bare airframe poles are tentatively identified  
AND SIMPLEFACT Literal poles are valid at check #3  
AND SIMPLEFACT Bare airframe poles are identified

SHARED ATTRIBUTE Literal roll spiral mode complexity IS real  
AND ATTRIBUTE Literal roll spiral mode complexity IS complex  
AND ATTRIBUTE Literal dutch roll mode complexity IS real  
AND ATTRIBUTE Literal dutch roll mode complexity IS complex

SHARED NUMERIC Number of numerical real zeros  
AND NUMERIC Number of numerical complex zero pairs  
AND NUMERIC Number of numerical real poles  
AND NUMERIC Number of numerical complex pole pairs  
AND NUMERIC Number of nonminimum phase numerical real zeros  
AND NUMERIC Number of nonminimum phase numerical complex zero pairs  
AND NUMERIC Number of unstable numerical real poles  
AND NUMERIC Number of unstable numerical complex pole pairs  
AND NUMERIC High frequency gain  
AND NUMERIC Inverse time constant of real zero #1  
AND NUMERIC Inverse time constant of real zero #2  
AND NUMERIC Inverse time constant of real zero #3  
AND NUMERIC Inverse time constant of real zero #4  
AND NUMERIC Inverse time constant of real zero #5  
AND NUMERIC Inverse time constant of real zero #6  
AND NUMERIC Damping ratio of complex zero pair #1  
AND NUMERIC natural frequency of complex zero pair #1  
AND NUMERIC Damping ratio of complex zero pair #2  
AND NUMERIC natural frequency of complex zero pair #2  
AND NUMERIC Damping ratio of complex zero pair #3



AND NUMERIC natural frequency of complex zero pair #3  
 AND NUMERIC Damping ratio of complex zero pair #4  
 AND NUMERIC natural frequency of complex zero pair #4  
 AND NUMERIC Damping ratio of complex zero pair #5  
 AND NUMERIC natural frequency of complex zero pair #5  
 AND NUMERIC Damping ratio of complex zero pair #6  
 AND NUMERIC natural frequency of complex zero pair #6  
 AND NUMERIC Inverse time constant of real pole #1  
 AND NUMERIC Inverse time constant of real pole #2  
 AND NUMERIC Inverse time constant of real pole #3  
 AND NUMERIC Inverse time constant of real pole #4  
 AND NUMERIC Inverse time constant of real pole #5  
 AND NUMERIC Inverse time constant of real pole #6  
 AND NUMERIC Damping ratio of complex pole pair #1  
 AND NUMERIC natural frequency of complex pole pair #1  
 AND NUMERIC Damping ratio of complex pole pair #2  
 AND NUMERIC natural frequency of complex pole pair #2  
 AND NUMERIC Damping ratio of complex pole pair #3  
 AND NUMERIC natural frequency of complex pole pair #3  
 AND NUMERIC Damping ratio of complex pole pair #4  
 AND NUMERIC natural frequency of complex pole pair #4  
 AND NUMERIC Damping ratio of complex pole pair #5  
 AND NUMERIC natural frequency of complex pole pair #5  
 AND NUMERIC Damping ratio of complex pole pair #6  
 AND NUMERIC natural frequency of complex pole pair #6  
 AND NUMERIC Number of bare airframe numerical real poles  
 AND NUMERIC Number of bare airframe numerical complex pole pairs  
 AND NUMERIC Inverse time constant of bare airframe real pole #1  
 AND NUMERIC Inverse time constant of bare airframe real pole #2  
 AND NUMERIC Damping ratio of bare airframe complex pole pair #1  
 AND NUMERIC natural frequency of bare airframe complex pole pair #1  
 AND NUMERIC ITs  
 AND NUMERIC ITr  
 AND NUMERIC Zd  
 AND NUMERIC Wd

!.....

! "SPECSET.FCT"

!

! AIRCRAFT DYNAMICS REQUIREMENTS SETUP (SPECSET)

! Externally defined facts used in SPECSET

! open loop aircraft model is setup

! open loop aircraft dynamics have been obtained

! open loop aircraft poles and zeros have been identified

! open loop aircraft spec comparison is complete

! open loop aircraft dynamics are adequate

! open loop aircraft assessment is complete

! Aircraft classification IS Class IV  
! Flight phase category IS Category CO

! Facts defined in SPECSET

SHARED SIMPLEFACT Dutch roll damping ratio spec is set  
AND SIMPLEFACT Dutch roll natural frequency spec is set  
AND SIMPLEFACT Dutch roll mode specs are set  
AND SIMPLEFACT Roll subsidence mode time constant spec is set  
AND SIMPLEFACT Roll subsidence mode specs are set  
AND SIMPLEFACT Dutch roll mode specs are set  
AND SIMPLEFACT Lateral directional specs are set  
AND SIMPLEFACT Requirements are set for the current case

SHARED NUMERIC Dutch roll damping ratio spec  
AND NUMERIC Roll subsidence mode time constant spec

!.....

! "ASSESSOL.FCT"

! FACTS for OPEN LOOP AIRCRAFT ASSESSEMENT (ASSESSOL)

SHARED SIMPLEFACT Complete aircraft data has been obtained  
AND SIMPLEFACT open loop aircraft model is setup  
AND SIMPLEFACT open loop aircraft dynamics have been obtained  
AND SIMPLEFACT open loop aircraft poles and zeros have been identified  
AND SIMPLEFACT open loop aircraft spec comparison is complete  
AND SIMPLEFACT open loop aircraft dynamics are adequate  
AND SIMPLEFACT open loop aircraft assessment is complete

!.....

! "SPECHKOL.FCT"

!

! BARE AIRCRAFT DYNAMICS SPECIFICATION CHECKER (SPECHKOL)

! Externally defined facts used in SPECKOL

! bare airframe dutch roll damping ratio  
! dutch roll damping ratio spec  
! bare airframe roll subsidence mode inverse time constant  
! Roll subsidence mode time constant spec

! Facts defined in SPECKOL

SHARED SIMPLEFACT bare airframe dutch roll damping ratio has been assessed  
AND SIMPLEFACT bare airframe dutch roll mode dynamics are adequate  
AND SIMPLEFACT bare airframe dutch roll mode has been assessed  
AND SIMPLEFACT bare airframe roll mode time constant has been assessed  
AND SIMPLEFACT bare airframe roll subsidence mode dynamics are adequate  
AND SIMPLEFACT bare airframe roll subsidence mode has been assessed

AND SIMPLEFACT bare airframe spiral mode dynamics are adequate  
AND SIMPLEFACT open loop aircraft dynamics are adequate  
AND SIMPLEFACT system has been compared with the specifications  
AND SIMPLEFACT open loop aircraft spec comparison is complete

SHARED ATTRIBUTE bare airframe dutch roll damping ratio assessment IS adequate  
AND ATTRIBUTE bare airframe dutch roll damping ratio assessment IS too low  
AND ATTRIBUTE bare airframe dutch roll natural frequency IS adequate  
AND ATTRIBUTE bare airframe roll subsidence mode time constant assessment IS adequate  
AND ATTRIBUTE bare airframe roll subsidence mode time constant assessment IS too high

!.....

!"PRSPCTUS.FCT"

!

!     FACTS for FCS PROSPECTUS EXPERT     {PRSPCTUS}

!     Externally defined facts used in PRSPCTUS

!     ATTRIBUTE Degrees of freedom for control ARE lateral directional axes

!     Facts defined in PRSPCTUS

AND SIMPLEFACT yaw damper is a candidate loop  
AND SIMPLEFACT roll damper is a candidate loop  
AND SIMPLEFACT sideslip to rudder is a candidate loop  
AND SIMPLEFACT lateral acceleration to rudder is a candidate loop  
AND SIMPLEFACT pitch rate to elevator is a candidate loop  
AND SIMPLEFACT candidate loops have been identified  
AND SIMPLEFACT Candidate loops have been reported  
AND SIMPLEFACT candidate architectures have been identified  
AND SIMPLEFACT RD&YD is a candidate architecture  
AND SIMPLEFACT RD&B\_DR is a candidate architecture  
AND SIMPLEFACT RD&AY\_DR is a candidate architecture  
AND SIMPLEFACT Candidate architectures have been ranked  
AND SIMPLEFACT Prospectus for control has been defined

SHARED ATTRIBUTE bare airframe roll mode time constant assessment IS adequate  
AND ATTRIBUTE bare airframe roll mode time constant assessment IS too high  
AND ATTRIBUTE First architecture for consideration IS RD&YD  
AND ATTRIBUTE Second architecture for consideration IS RD&B\_DR  
AND ATTRIBUTE Third architecture for consideration IS RD&AY\_DR

!     Initial values of shared attributes

!     AND ATTRIBUTE bare airframe roll mode time constant assessment IS:

!     no assessment

!     AND ATTRIBUTE First architecture for consideration IS undefined

!     AND ATTRIBUTE Second architecture for consideration IS undefined

!     AND ATTRIBUTE Third architecture for consideration IS undefined

!.....

```

!"ARCH.FCT"
!
! FACTS for ARCHITECTURE SELECTION EXPERT      (ARCH)

! Externally defined facts used in ARCH

! ATTRIBUTE Degrees of freedom for control ARE lateral directional axes
! ATTRIBUTE First architecture for consideration IS RD&YD
! ATTRIBUTE RD&YD assessment IS no assessment
! ATTRIBUTE RD&YD assessment IS assessed and inadequate

```

```
! Facts defined in ARCH
```

```

SHARED SIMPLEFACT Current architecture has been selected
AND SIMPLEFACT Selection of current architecture has been completed
AND SIMPLEFACT First loop to design has been specified

```

```

SHARED ATTRIBUTE Current architecture IS RD&YD
AND ATTRIBUTE Current architecture IS RD&B_DR
AND ATTRIBUTE Current architecture IS RD&AY_DR
AND ATTRIBUTE First loop to design IS yaw damper
AND ATTRIBUTE First loop to design IS roll damper
AND ATTRIBUTE First loop to design IS B_DR
AND ATTRIBUTE First loop to design IS AY_DR

```

```
! Initial values of attributes
```

```

! AND ATTRIBUTE Current architecture IS undefined
! AND ATTRIBUTE First loop to design IS undefined

```

```
!.....
```

```

!"DESIGN.FCT"
!
! FACTS for FCS LOOP DESIGN EXPERT      (DESIGN)

```

```
! Externally defined facts used in DESIGN
```

```

! Yaw damper loop has been designed
! Current architecture IS RD&YD
! First loop to design IS yaw damper
! Yaw damper loop assessment IS assessed and inadequate
! Yaw damper loop assessment IS assessed and adequate
! Roll damper loop assessment IS assessed and inadequate
! Roll damper loop assessment IS assessed and adequate

```

```
! Facts defined in DESIGN
```

```

SHARED SIMPLEFACT Current loop has been specified
AND SIMPLEFACT Current loop connections are set for design

```

AND SIMPLEFACT Current system design model is setup  
AND SIMPLEFACT Current loop must be designed  
AND SIMPLEFACT Current architecture has been designed

SHARED ATTRIBUTE Current loop IS yaw damper  
AND ATTRIBUTE Current loop IS roll damper  
AND ATTRIBUTE Current loop IS B\_DR  
AND ATTRIBUTE Current loop IS AY\_DR  
AND ATTRIBUTE Yaw damper loop connection IS open  
AND ATTRIBUTE Roll damper loop connection IS open  
AND ATTRIBUTE Sideslip to rudder loop connection IS open  
AND ATTRIBUTE Lateral acceleration to rudder loop connection IS open  
AND ATTRIBUTE Yaw damper loop connection IS closed  
AND ATTRIBUTE Roll damper loop connection IS closed  
AND ATTRIBUTE Sideslip to rudder loop connection IS closed  
AND ATTRIBUTE Lateral acceleration to rudder loop connection IS closed  
AND ATTRIBUTE RD&YD assessment IS assessed and inadequate  
AND ATTRIBUTE RD&YD assessment IS assessed and adequate

! Initial values of attributes

! AND ATTRIBUTE Current loop IS undefined  
! AND ATTRIBUTE RD&YD assessment IS no assessment

!.....

! "YAWDMPR.FCT"

! YAW DAMPER EXPERT {YAWDMPR}

! Externally defined facts used in YAWDMPR

! Specify loop gain directly  
! Loop gain has been specified directly  
! Examine Root Locus to set the gain  
! Loop gain has been specified from root locus  
! Examine Bode Siggy to set the gain  
! Loop gain has been specified from Bode Siggy  
! Loop gain is defined  
! Terminate gain selection  
! Return to yawdamper module

! Aircraft classification IS Class IV  
! dutch roll damping ratio assessment IS too low  
! dutch roll damping ratio assessment IS adequate

SHARED NUMERIC Wrs  
AND NUMERIC Wd

! Facts Defined in YAWDMPR

SHARED SIMPLEFACT Perform complete yaw damper design  
 AND SIMPLEFACT Define yaw damper feedback equalization  
 AND SIMPLEFACT Define yaw damper gain  
 AND SIMPLEFACT Yaw damper measurement query has been made  
 AND SIMPLEFACT Yaw damper type has been determined  
 AND SIMPLEFACT Yaw damper measurements are adequate  
 AND SIMPLEFACT Aircraft operation is limited to low AOA  
 AND SIMPLEFACT Aircraft operation is restricted to low AOA  
 AND SIMPLEFACT Yaw damper measurement query has been made  
 AND SIMPLEFACT Yaw damper measurements have been defined  
 AND SIMPLEFACT Rate gyro tilt angle has been queried  
 AND SIMPLEFACT Rate gyro tilt angle has been defined  
 AND SIMPLEFACT Stability axis yaw damper should be designed  
 AND SIMPLEFACT Measurement blending coefficients have been queried  
 AND SIMPLEFACT Yaw damper feedback signal has been defined  
 AND SIMPLEFACT Basic feedback transfer function has been obtained  
 AND SIMPLEFACT rf|dr complex dipole is well separated  
 AND SIMPLEFACT Complex dipole is suitable for a yaw damper  
 AND SIMPLEFACT rf|dr pole zero configuration has been examined  
 AND SIMPLEFACT Yaw damper washout must be reported  
 AND SIMPLEFACT Yaw damper washout is defined  
 AND SIMPLEFACT Yaw damper open loop transfer function has been created  
 AND SIMPLEFACT Gain selection must be performed  
 AND SIMPLEFACT yaw damper gain is defined  
 AND SIMPLEFACT Yaw damper loop has been designed  
 AND SIMPLEFACT a yaw damper is to be designed  
 ! AND SIMPLEFACT previous design has been discarded  
 ! AND SIMPLEFACT previous yaw damper measurement has been discarded  
 ! AND SIMPLEFACT previous yaw damper washout has been discarded  
 ! AND SIMPLEFACT previous yaw damper gain has been discarded  
 AND SIMPLEFACT yaw damper is ready for assessment  
 AND SIMPLEFACT Current system assessment model is setup  
 AND SIMPLEFACT requirement comparison is complete  
 AND SIMPLEFACT System dynamics must be obtained  
 AND SIMPLEFACT System dynamics have been obtained  
 AND SIMPLEFACT System dynamics have been obtained  
 AND SIMPLEFACT System poles and zeros must be identified  
 AND SIMPLEFACT System poles and zeros have been identified  
 AND SIMPLEFACT Yaw damper is ready for assessment  
 AND SIMPLEFACT Yaw damper open loop transfer function has been generated  
 AND SIMPLEFACT Yaw damper open loop transfer function has been transmitted  
 AND SIMPLEFACT Yaw damper assessment dynamics have been generated  
 AND SIMPLEFACT Yaw damper assessment dynamics have been transmitted  
 AND SIMPLEFACT Yaw damper dynamics are ready for assessment

SHARED ATTRIBUTE Yaw damper measurement IS Yaw rate  
 AND ATTRIBUTE Yaw damper measurement IS roll rate  
 AND ATTRIBUTE Yaw damper type IS Yaw roll type  
 AND ATTRIBUTE Yaw damper type IS Yaw only type  
 AND ATTRIBUTE Yaw damper loop assessment IS assessed and inadequate  
 AND ATTRIBUTE Yaw damper loop assessment IS assessed and adequate

```

SHARED NUMERIC Rate gyro tilt angle
AND NUMERIC Yaw rate blending coefficient
AND NUMERIC Roll rate blending coefficient
AND NUMERIC Yaw damper washout inverse time constant
AND NUMERIC Yaw damper washout time constant
AND NUMERIC yaw damper gain
AND NUMERIC N1
AND NUMERIC N2
AND NUMERIC N4
AND NUMERIC N3
AND NUMERIC N5
AND NUMERIC N6
AND NUMERIC N7

```

```

SHARED STRING S1
AND STRING S2

```

```

!.....

```

```

! "ROLLDMPR.FCT"

```

```

!
! ROLL DAMPER EXPERT (ROLLDMPR)

```

```

! Externally defined facts used in ROLLDMPR

```

```

! Specify loop gain directly
! Loop gain has been specified directly
! Examine Root Locus to set the gain
! Loop gain has been specified from root locus
! Examine Bode siggy to set the gain
! Loop gain has been specified from Bode Siggy
! Loop gain has been specified
! Loop gain is defined
! Terminate gain selection
! Return to calling module

```

```

! roll subsidence mode time constant assessment IS too high
! roll subsidence mode time constant assessment IS adequate

```

```

! loop gain

```

```

! Facts defined in ROLLDMPR

```

```

SHARED SIMPLEFACT Define roll damper feedback equalization
AND SIMPLEFACT Define lead time constant
AND SIMPLEFACT Define lag time constant
AND SIMPLEFACT Define roll damper gain
AND SIMPLEFACT Roll damper lead inverse time constant has been defined
AND SIMPLEFACT Roll damper lag inverse time constant has been defined
AND SIMPLEFACT Define roll damper feedback equalization
AND SIMPLEFACT Pure gain roll damper O.L. transfer function is generated

```

```

AND SIMPLEFACT Pure gain roll damper has standard root locus topology
AND SIMPLEFACT Roll damper requires lead equalization
AND SIMPLEFACT Dutch roll locus goes to rigid body zero
AND SIMPLEFACT Pure gain roll damper root locus has been examined
AND SIMPLEFACT Roll damper requires lag equalization
AND SIMPLEFACT Roll damper feedback equalization has been defined
AND SIMPLEFACT Roll damper open loop transfer function is created
AND SIMPLEFACT Gain selection must be performed
AND SIMPLEFACT roll damper gain is defined
AND SIMPLEFACT roll damper loop has been designed
AND SIMPLEFACT roll damper is ready for assessment
AND SIMPLEFACT Current system assessment model is setup
AND SIMPLEFACT requirement comparison is complete
!   System dynamics must be obtained
!   System dynamics have been obtained
!   System poles and zeros must be identified
!   System poles and zeros have been identified
AND SIMPLEFACT Roll damper is ready for assessment
!   System requirement check has been made
AND SIMPLEFACT Pure gain roll damper OLF has been generated
AND SIMPLEFACT Roll damper open loop transfer function has been generated
AND SIMPLEFACT Roll damper open loop transfer function has been transmitted
AND SIMPLEFACT Roll damper assessment dynamics have been generated
AND SIMPLEFACT Roll damper assessment dynamics have been transmitted
AND SIMPLEFACT Roll damper dynamics are ready for assessment

```

```

SHARED ATTRIBUTE Roll damper loop assessment IS assessed and inadequate
AND ATTRIBUTE Roll damper loop assessment IS assessed and adequate

```

```

SHARED NUMERIC Roll damper lag inverse time constant
AND NUMERIC Roll damper lead inverse time constant
AND NUMERIC Roll damper gain
AND NUMERIC N21
AND NUMERIC N22
AND NUMERIC N23

```

```
!.....
```

```

! "ASSESS.FCT"
!
! FACTS for AIRCRAFT DYNAMICS ASSESSMENT (ASSESS)

! Externally defined facts used in ASSESS

! requirements are set for the current case
! dutch roll damping ratio
! dutch roll damping ratio spec
! roll subsidence mode inverse time constant
! Roll subsidence mode time constant spec

! ATTRIBUTE Current loop

```



! Facts defined in ASSESS

SHARED SIMPLEFACT dutch roll damping ratio has been assessed  
AND SIMPLEFACT dutch roll mode dynamics are adequate  
AND SIMPLEFACT dutch roll mode has been compared with the requirements  
AND SIMPLEFACT roll mode time constant has been assessed  
AND SIMPLEFACT roll subsidence mode dynamics are adequate  
AND SIMPLEFACT roll subsidence mode has been assessed  
AND SIMPLEFACT modal dynamics are adequate  
AND SIMPLEFACT system has been compared with the requirements  
AND SIMPLEFACT requirement comparison is complete

SHARED ATTRIBUTE dutch roll damping ratio assessment IS adequate  
AND ATTRIBUTE dutch roll damping ratio assessment IS too low  
AND ATTRIBUTE roll subsidence mode time constant assessment IS adequate  
AND ATTRIBUTE roll subsidence mode time constant assessment IS too high

SHARED NUMERIC spiral mode inverse time constant  
AND NUMERIC roll subsidence mode inverse time constant  
AND NUMERIC Dutch roll damping ratio  
AND NUMERIC Dutch roll natural frequency

!.....

! "GAINSEL.FCT"

! Loop Gain Selection Expert (GAINSEL)

! Externally defined facts used in GAINSEL

! Current loop IS Yaw damper

! Current loop IS Roll damper

! Facts defined in GAINSEL

SHARED SIMPLEFACT Specify loop gain directly  
AND SIMPLEFACT Loop gain has been specified directly  
AND SIMPLEFACT Examine Root Locus to set the gain  
AND SIMPLEFACT Loop gain has been specified from root locus  
AND SIMPLEFACT Examine Bode siggy to set the gain  
AND SIMPLEFACT Loop gain has been specified from Bode Siggy  
AND SIMPLEFACT Loop gain has been specified  
AND SIMPLEFACT Loop gain is defined  
AND SIMPLEFACT Terminate gain selection  
AND SIMPLEFACT Return to calling module  
AND SIMPLEFACT Yaw damper gain is defined  
AND SIMPLEFACT Roll damper gain is defined

SHARED NUMERIC Loop gain

!.....  
!

! Augmented Aircraft Pole and Zero Identification (ROOTID)

! Externally defined facts used in ROOTID

! Current architecture IS RD&YD  
! Roll damper loop connection IS open  
! Roll damper loop connection IS closed  
! Yaw damper loop connection IS open  
! Yaw damper loop connection IS closed  
! Current loop IS Yaw damper  
! Current loop IS Roll damper  
! Calling expert IS YAWDMPR expert  
! Calling expert IS ROLLDMPR expert

! Facts defined in ROOTID

SHARED SIMPLEFACT System poles and zeros have been identified  
AND SIMPLEFACT System identification transfer function has been read  
AND SIMPLEFACT System poles and zeros have been identified  
AND SIMPLEFACT System poles are identified  
AND SIMPLEFACT Return to calling expert

SHARED NUMERIC ITs'  
AND NUMERIC ITr'  
AND NUMERIC Zd'  
AND NUMERIC Wd'  
AND NUMERIC ITs''  
AND NUMERIC ITr''  
AND NUMERIC Zd''  
AND NUMERIC Wd''

!.....

! Creation of Augmented Aircraft Model (SYSMOD)

! Externally defined facts used in SYSMOD

! Roll rate blending coefficient  
! Yaw rate blending coefficient  
! Roll damper gain  
! Roll damper lead inverse time constant  
! Roll damper lag inverse time constant  
! yaw damper gain  
! Yaw damper washout inverse time constant

! Facts defined in SYSMOD

SHARED SIMPLEFACT System model must be generated  
AND SIMPLEFACT FCS parameters are set  
AND SIMPLEFACT System model has been generated  
AND SIMPLEFACT Return to calling expert

SHARED ATTRIBUTE Expert requesting SYSMOD IS DESIGN expert  
AND ATTRIBUTE Expert requesting SYSMOD IS YAWDMPR expert  
AND ATTRIBUTE Expert requesting SYSMOD IS ROLLDMPR expert

!.....

!

! Transfer Function Extraction (TFEXT)

! Facts defined in TFEXT

SHARED SIMPLEFACT Return to calling expert  
AND SIMPLEFACT System model has been generated  
AND SIMPLEFACT Specified system transfer function has been transmitted  
AND SIMPLEFACT Return to calling expert

SHARED ATTRIBUTE Calling expert IS YAWDMPR expert  
AND ATTRIBUTE Calling expert IS ROLLDMPR expert

SHARED STRING Transfer function \$\$g filename

**MULTI.SHR**

! "MULTI.SHR"  
!  
! Multiple Attributes Declarations  
!  
! The Multiple Attributes Declaration is stored in the "include" file named  
! "MULTI.SHR".

MULTI Yaw damper measurement

**EXHAUSTV.SHR**

! "EXHAUSTV.SHR"  
!  
! Exhaustive Simplefacts Declarations  
!  
! The EXHAUSTIVE SIMPLEFACTS Declaration is stored in the "include" file  
! named "EXHAUSTV.SHR". No simplefacts are declared to EXHAUSTIVE at this  
! time.  
!.....

! AIRCRAFT DEFINITION (AIRCRAFT)

EXHAUSTIVE Aircraft has been designated  
AND Aircraft has been classified  
AND Degrees of freedom for control have been defined  
AND aircraft basic data file has been read  
AND aileron actuator bandwidth has been specified  
AND rudder actuator bandwidth has been specified  
AND aileron channel effective time delay has been specified  
AND rudder channel effective time delay has been specified  
AND aileron actuator transfer function has been generated  
AND rudder actuator transfer function has been generated  
AND aileron time delay transfer function has been generated  
AND rudder time delay transfer function has been generated  
AND Actuator dynamics have been defined  
AND High frequency dynamics have been defined  
AND Aircraft basic data has been obtained  
AND Aircraft basic data must be obtained

!.....

! FLIGHT CONDITION DEFINITION (FLTCOND)

AND Flight and trim conditions have been obtained  
AND Stability and control derivatives have been obtained  
AND State matrix calculations have been obtained  
AND Bare airframe dynamics have been obtained  
AND Literal approximate factors have been obtained  
AND Complete aircraft data has been obtained  
AND Requirements must be set for the current case

!.....

! AIRCRAFT DYNAMICS REQUIREMENTS SETUP (SPECSET)

AND Dutch roll damping ratio spec is set  
AND Dutch roll natural frequency spec is set  
AND Dutch roll mode specs are set  
AND Roll subsidence mode time constant spec is set  
AND Roll subsidence mode specs are set  
AND Dutch roll mode specs are set  
AND Lateral directional specs are set  
AND Requirements are set for the current case

!.....

! FACTS for OPEN LOOP AIRCRAFT ASSESSEMENT (ASSESSOL)

AND Complete aircraft data has been obtained  
AND open loop aircraft model is setup  
AND open loop aircraft dynamics have been obtained  
AND open loop aircraft poles and zeros have been identified  
AND open loop aircraft spec comparison is complete  
AND open loop aircraft dynamics are adequate  
AND open loop aircraft assessment is complete

!.....

! BARE AIRCRAFT DYNAMICS SPECIFICATION CHECKER (SPECHKOL)

AND bare airframe dutch roll damping ratio has been assessed  
AND bare airframe dutch roll mode dynamics are adequate  
AND bare airframe dutch roll mode has been assessed  
AND bare airframe roll mode time constant has been assessed  
AND bare airframe roll subsidence mode dynamics are adequate  
AND bare airframe roll subsidence mode has been assessed  
AND bare airframe spiral mode dynamics are adequate  
AND open loop aircraft dynamics are adequate  
AND system has been compared with the specifications  
AND open loop aircraft spec comparison is complete

!.....

! FACTS for FCS PROSPECTUS EXPERT (PRSPCTUS)

AND yaw damper is a candidate loop  
AND roll damper is a candidate loop  
AND sideslip to rudder is a candidate loop  
AND lateral acceleration to rudder is a candidate loop  
AND pitch rate to elevator is a candidate loop  
AND candidate loops have been identified  
AND Candidate loops have been reported  
AND candidate architectures have been identified  
AND RD&YD is a candidate architecture  
AND RD&B\_DR is a candidate architecture  
AND RD&AY\_DR is a candidate architecture  
AND Candidate architectures have been ranked  
AND Prospectus for control has been defined

!.....

! FACTS for ARCHITECTURE SELECTION EXPERT (ARCH)

AND Current architecture has been selected  
AND Selection of current architecture has been completed



AND First loop to design has been specified

!.....

! FACTS for FCS LOOP DESIGN EXPERT (DESIGN)

AND Current loop has been specified  
AND Current loop connections are set for design  
AND Current system design model is setup  
AND Current loop must be designed  
AND Current architecture has been designed

!.....

! FACTS for YAWDMPR

AND Perform complete yaw damper design  
AND Define yaw damper feedback equalization  
AND Define yaw damper gain  
AND Yaw damper measurement query has been made  
AND Yaw damper type has been determined  
AND Yaw damper measurements are adequate  
! AND Aircraft operation is limited to low AOA  
AND Aircraft operation is restricted to low AOA  
AND Yaw damper measurement query has been made  
AND Yaw damper measurements have been defined  
AND Rate gyro tilt angle has been queried  
AND Rate gyro tilt angle has been defined  
AND Stability axis yaw damper should be designed  
AND Measurement blending coefficients have been queried  
AND Yaw damper feedback signal has been defined  
AND Basic feedback transfer function has been obtained  
AND  $rf|dr$  complex dipole is well separated  
AND Complex dipole is suitable for a yaw damper  
AND  $rf|dr$  pole zero configuration has been examined  
AND Yaw damper washout must be reported  
AND Yaw damper washout is defined  
AND Yaw damper open loop transfer function has been created  
AND Gain selection must be performed  
AND yaw damper gain is defined  
AND Yaw damper loop has been designed  
AND a yaw damper is to be designed  
AND previous design has been discarded  
AND previous yaw damper measurement has been discarded  
AND previous yaw damper washout has been discarded  
AND previous yaw damper gain has been discarded  
AND yaw damper is ready for assessment  
AND Current system assessment model is setup  
AND requirement comparison is complete  
AND System dynamics must be obtained  
AND System dynamics have been obtained  
AND System dynamics have been obtained

AND System poles and zeros must be identified  
AND System poles and zeros have been identified  
AND Yaw damper is ready for assessment

!.....

! ROLL DAMPER EXPERT (ROLLDMPR)

AND Define roll damper feedback equalization  
AND Define lead time constant  
AND Define lag time constant  
AND Define roll damper gain  
AND Roll damper lead inverse time constant has been defined  
AND Roll damper lag inverse time constant has been defined  
AND Define roll damper feedback equalization  
AND Pure gain roll damper O.L. transfer function is generated  
AND Pure gain roll damper has standard root locus topology  
AND Roll damper requires lead equalization  
AND Dutch roll locus goes to rigid body zero  
AND Pure gain roll damper root locus has been examined  
AND Roll damper requires lag equalization  
AND Roll damper feedback equalization has been defined  
AND Roll damper open loop transfer function is created  
AND Gain selection must be performed  
AND roll damper gain is defined  
AND roll damper loop has been designed  
AND roll damper is ready for assessment  
AND Current system assessment model is setup  
AND requirement comparison is complete  
! System dynamics must be obtained  
! System dynamics have been obtained  
! System poles and zeros must be identified  
! System poles and zeros have been identified  
AND Roll damper is ready for assessment  
! System requirement check has been made

!.....

! FACTS for AIRCRAFT DYNAMICS ASSESSMENT (ASSESS)

AND dutch roll damping ratio has been assessed  
AND dutch roll mode dynamics are adequate  
AND dutch roll mode has been compared with the requirements  
AND roll mode time constant has been assessed  
AND roll subsidence mode dynamics are adequate  
AND roll subsidence mode has been assessed  
AND modal dynamics are adequate  
AND system has been compared with the requirements  
AND requirement comparison is complete

!.....

! "GAINSEL.FCT"

AND Specify loop gain directly  
AND Loop gain has been specified directly  
AND Examine Root Locus to set the gain  
AND Loop gain has been specified from root locus  
AND Examine Bode siggy to set the gain  
AND Loop gain has been specified from Bode Siggy  
AND Loop gain has been specified  
AND Loop gain is defined  
AND Terminate gain selection  
AND Return to calling module  
AND Yaw damper gain is defined  
AND Roll damper gain is defined

**INITATT**

```
! "INITATT"
!  
! Initialization of Attribute Values
!  
! The initial attribute values are stored in the "include" file named
! "INITATT"
!.....
```

```
! FACTS for FCS LOOP DESIGN EXPERT (DESIGN)
```

```
AND Yaw damper loop connection IS open
AND Roll damper loop connection IS open
AND Sideslip to rudder loop connection IS open
AND Lateral acceleration to rudder loop connection IS open
```

```
!.....
```

```
! FACTS for (ARCH)
```

```
AND RD&YD assessment IS assessed and inadequate CF 0
AND RD&YD assessment IS assessed and adequate CF 0
```

```
!.....
```

```
AND Yaw damper loop assessment IS assessed and inadequate CF 0
AND Yaw damper loop assessment IS assessed and adequate CF 0
```

```
!.....
```

```
AND Roll damper loop assessment IS assessed and inadequate CF 0
AND Roll damper loop assessment IS assessed and adequate CF 0
```

**GENERATE.PRL**

```
! "GENERATE"
!  
TITLE FLIGHT CONTROL SYSTEM GENERATOR (GENERATE) DISPLAY
```

This Expert functions as an executive to assist in managing the overall flight control design process.

To continue, press F3

SYSTEMS TECHNOLOGY, INC Hawthorne, CA  
Copyright (C) 1988

```
!.....  
!  
! Shared Facts Declarations  
!  
! The Shared Facts Declaration is stored in the "include" file named  
! "SHAREFCT.SHR" and combined with this knowledge base during compilation.  
!  
! $SHAREFCT.SHR  
!  
!.....  
!  
! Data Type Declarations  
!  
!.....  
!  
! Parameter Initialization Statements  
  
INIT yaw damper loop has been designed CF 0  
AND roll damper loop has been designed CF 0  
AND B_DR loop has been designed CF 0  
AND AY_DR loop has been designed CF 0  
AND Roll damper lead inverse time constant := 2000.  
AND Roll damper lag inverse time constant := 2000.  
AND Roll damper gain := 0.0  
AND Yaw damper gain := 0.0  
AND Yaw damper washout inverse time constant := .0001  
AND g := 32.2 ! Acceleration due to gravity, ft|sec|sec  
  
! Initialization of Attribute Values  
!  
!.....  
!  
! FACTS for FCS LOOP DESIGN EXPERT (DESIGN)
```

INIT Yaw damper loop connection IS open  
AND Roll damper loop connection IS open  
AND Sideslip to rudder loop connection IS open  
AND Lateral acceleration to rudder loop connection IS open

!.....

! FACTS for {ARCH}

AND RD&YD assessment IS assessed and inadequate CF 0  
AND RD&YD assessment IS assessed and adequate CF 0

!.....

AND Yaw damper loop assessment IS assessed and inadequate CF 0  
AND Yaw damper loop assessment IS assessed and adequate CF 0

!.....

AND Roll damper loop assessment IS assessed and inadequate CF 0  
AND Roll damper loop assessment IS assessed and adequate CF 0

!.....

!

! Control Element Selectors

THRESHOLD - 100  
CONFIDENCE OFF  
GOALSELECT ON  
UNKNOWN CONTINUE  
\$EXHAUSTV.SHR

!.....

!

! Multivalued Attribute Declarations

!

! The "MULTI" Declaration of multivalued attributes is stored in the  
! "include" file named "MULTI.SHR" and combined with this knowledge  
! base during compilation.

\$MULTI.SHR

!.....

!

!

! Goal Outline

- 1. Previous session data restoration option exercised
  - 1.1. Specify a new aircraft for FCS design
    - 1.1.1 Aircraft basic data must be obtained



- 1.2. Specify a new flight condition for the current aircraft
  - 1.2.1 Complete aircraft data must be obtained
- 1.3. Select an FCS architecture for design
  - 1.3.1 Current architecture must be selected
- 1.4. Select a loop for design within the current architecture
  - 1.4.1 Current loop must be selected
- 1.5. Store current design data on file
  - 1.5.1 Current context must be stored

!-----  
!  
! Rules

```
RULE for restoring previous context
IF ASK Previous design data should be restored
AND Previous design data should be restored
THEN Previous session data restoration option exercised
AND CONTEXT RESTORE C:\FCSXPRT\LASTDSGN.CTX
AND DISPLAY context restore
ELSE Previous session data restoration option exercised
```

```
RULE For obtaining aircraft basic data
IF Specify a new aircraft for FCS design
THEN Aircraft basic data must be obtained
AND FORGET Aircraft has been designated
AND FORGET Aircraft has been classified
AND FORGET Degrees of freedom for control have been defined
AND FORGET aileron actuator bandwidth has been specified
AND FORGET rudder actuator bandwidth has been specified
AND FORGET aileron channel effective time delay has been specified
AND FORGET rudder channel effective time delay has been specified
AND FORGET aileron actuator transfer function has been generated
AND FORGET rudder actuator transfer function has been generated
AND FORGET aileron time delay transfer function has been generated
AND FORGET rudder time delay transfer function has been generated
AND FORGET Actuator dynamics have been defined
AND FORGET High frequency dynamics have been defined
AND FORGET aircraft basic data file has been read
AND FORGET Aircraft basic data has been obtained
AND FORGET Aircraft classification
AND FORGET aircraft type
AND FORGET Degrees of freedom for control
AND CHAIN C:\FCSXPRT\AIRCRAFT
```

```
RULE For obtaining complete aircraft data
IF Specify a new flight condition for the current aircraft
AND Aircraft basic data has been obtained
THEN Complete aircraft data must be obtained
AND FORGET Flight and trim conditions have been obtained
```

AND FORGET Stability and control derivatives have been obtained  
AND FORGET State matrix calculations have been obtained  
AND FORGET Bare airframe dynamics have been obtained  
AND FORGET Literal approximate factors have been obtained  
AND FORGET Complete aircraft data has been obtained  
AND FORGET Requirements must be set for the current case  
AND FORGET Flight phase category  
AND CHAIN C:\FCSXPRT\FLTCOND

RULE for selecting the current FCS architecture  
IF Select an FCS architecture for design  
AND Prospectus for control has been defined  
THEN Current architecture must be selected  
AND FORGET Current architecture has been selected  
AND FORGET Selection of current architecture has been completed  
AND FORGET First loop to design has been specified  
AND CHAIN C:\FCSXPRT\ARCH

RULE for selecting the current loop for design  
IF Select a loop for design within the current architecture  
AND Selection of current architecture has been completed  
THEN Current loop must be selected  
AND FORGET Current loop has been specified  
AND FORGET Current loop connections are set for design  
AND FORGET Current system design model is setup  
AND FORGET Current loop must be designed  
AND FORGET Current architecture has been designed  
AND CHAIN C:\FCSXPRT\DESIGN

RULE for saving current context  
IF Store current design data on file  
AND ASK design data set is to be saved  
AND design data set is to be saved  
AND FORGET Specify a new aircraft for FCS design  
AND FORGET Aircraft basic data must be obtained  
AND FORGET Specify a new flight condition for the current aircraft  
AND FORGET Complete aircraft data must be obtained  
AND FORGET Select an FCS architecture for design  
AND FORGET Current architecture must be selected  
AND FORGET Select a loop for design within the current architecture  
AND FORGET Current loop must be selected  
AND FORGET Store current design data on file  
AND FORGET Current context must be stored  
THEN Current context must be stored  
AND CONTEXT SAVE C:\FCSDAT\LASTDSGN.CTX  
AND DISPLAY context message  
AND CYCLE

!  
!  
! Information Display Text

DISPLAY context restore

The data set for the previous design session (or the last session saved) has now been restored so that the design work can be continued.

To continue, press F2

DISPLAY context message

The complete data set for this design session has now been saved for future use on the file "LASTDSGN.CTX".

To continue, press F2

!  
END

**AIRCRAFT.PRL**

```
! "AIRCRAFT.PRL"
!  
TITLE AIRCRAFT DEFINITION (AIRCRAFT) DISPLAY
```

This expert assists in the specification of the aircraft for which a flight control system is to be designed. This includes obtaining all geometric and mass property information which is independent of flight condition.

Note that all previous DATA AND DESIGN RESULTS WILL BE DISCARDED.

To continue, press F3

SYSTEMS TECHNOLOGY, INC Hawthorne, CA  
Copyright (C) 1988

```
!.....  
!  
! Shared Facts Declarations  
!  
! The Shared Facts Declaration is stored in the "include" file named  
! "SHAREFCT.SHR" and combined with this knowledge base during compilation.
```

\$SHAREFCT.SHR

```
!.....  
!  
! Data Type Declarations  
!  
!.....
```

```
! Parameter Initialization Statements  
!
```

```
INIT St7="C:\STI"  
AND St8="CC.EXE"  
AND St9="@FORWARD.MAC"  
REINIT St7="C:\STI"  
AND St8="CC.EXE"  
AND St9="@FORWARD.MAC"
```

```
!.....  
!  
! Control Element Selectors
```

```
THRESHOLD = 100  
CONFIDENCE OFF
```

GOALSELECT ON  
UNKNOWN CONTINUE  
\$EXHAUSTV.SHR

!.....  
!  
! Multiattributed Objects Declarations  
!  
! The "MULTI" Declaration of multiattributed objects is stored in the  
! "include" file named "MULTI.SHR" and combined with this knowledge base  
! during compilation.

\$MULTI.SHR

!.....  
!  
! Goal Outline  
  
1. Aircraft has been designated  
  1.1 Aircraft has been classified  
    1.1.1 Degrees of freedom for control have been defined  
      1.1.1.1 Aircraft basic data has been obtained

!-----

!  
! Rules

!  
RULE for identifying the aircraft  
IF ASK Aircraft designation  
THEN Aircraft has been designated

RULE for aircraft classification  
IF Aircraft classification IS Class I  
OR Aircraft classification IS Class II  
OR Aircraft classification IS Class III  
OR Aircraft classification IS Class IV  
THEN Aircraft has been classified

RULE for Class IV aircraft  
IF aircraft type IS Fighter  
OR aircraft type IS Interceptor  
OR aircraft type IS Attack  
OR aircraft type IS Tactical reconnaissance  
OR aircraft type IS Observation  
OR aircraft type IS Trainer for Class IV aircraft  
OR aircraft type IS generic high maneuverability aircraft  
THEN Aircraft has been classified  
AND Aircraft classification IS Class IV

RULE for defining Degrees of freedom for control  
IF Degrees of freedom for control ARE lateral directional axes

OR Degrees of freedom for control ARE longitudinal axes  
THEN Degrees of freedom for control have been defined

RULE for reading in aircraft basic data file  
IF Degrees of freedom for control have been defined  
AND DISPLAY basic data read  
AND READ C:\FCSDAT\ACDATA.PRM  
DATA Aircraft Kind  
DATA Aircraft Class  
DATA Planform Area  
DATA Mean Aerodynamic Cord  
DATA Wing Span  
DATA Thrust Inclination  
DATA Weight  
DATA X Center of Gravity Mac  
DATA X Center of Gravity  
DATA Y Center of Gravity  
DATA Z Center of Gravity  
DATA X Moment of Inertia  
DATA Y Moment of Inertia  
DATA Z Moment of Inertia  
DATA XY Product of Inertia  
DATA XZ Product of Inertia  
DATA YZ Product of Inertia  
THEN aircraft basic data file has been read

!  
!.....  
!

! Rules for obtaining actuator and high frequency dynamics

RULE for obtaining aileron actuator bandwidth  
IF ASK roll control actuator bandwidth  
AND roll control actuator bandwidth > 0  
THEN aileron actuator bandwidth has been specified  
ELSE DISPLAY negative bandwidth  
AND LOOP

RULE for obtaining rudder actuator bandwidth  
IF ASK rudder actuator bandwidth  
AND rudder actuator bandwidth > 0  
THEN rudder actuator bandwidth has been specified  
ELSE DISPLAY negative bandwidth  
AND LOOP

RULE for obtaining effective time delay in aileron channel  
IF ASK roll control channel effective time delay  
AND roll control channel effective time delay > 0  
THEN aileron channel effective time delay has been specified  
ELSE DISPLAY negative time delay  
AND LOOP

RULE for obtaining effective time delay in aileron channel  
IF ASK rudder channel effective time delay  
AND rudder channel effective time delay > 0  
THEN rudder channel effective time delay has been specified  
ELSE DISPLAY negative time delay  
AND LOOP

!.....  
!

! Rules for creating actuator and effective time delay transfer functions

RULE for generating aileron actuator transfer function  
IF aileron actuator bandwidth has been specified  
THEN aileron actuator transfer function has been generated

RULE for generating rudder actuator transfer function  
IF rudder actuator bandwidth has been specified  
THEN rudder actuator transfer function has been generated

RULE for generating aileron effective time delay transfer function  
IF aileron channel effective time delay has been specified  
THEN aileron time delay transfer function has been generated

RULE for generating rudder effective time delay transfer function  
IF rudder channel effective time delay has been specified  
THEN rudder time delay transfer function has been generated  
AND ACTIVATE C:\STI\PROCALL.EXE

SEND St7  
SEND St8  
SEND St9  
SEND roll control actuator bandwidth  
SEND rudder actuator bandwidth  
SEND roll control channel effective time delay  
SEND rudder channel effective time delay

RULE for definition of actuator dynamics  
IF aileron actuator transfer function has been generated  
AND rudder actuator transfer function has been generated  
THEN Actuator dynamics have been defined

RULE for definition of high frequency dynamics  
IF aileron time delay transfer function has been generated  
AND rudder time delay transfer function has been generated  
THEN High frequency dynamics have been defined

!.....  
!

! Rules for concluding aircraft basic data definition

RULE for concluding aircraft basic data definition  
IF aircraft basic data file has been read  
AND Actuator dynamics have been defined  
AND High frequency dynamics have been defined



THEN Aircraft basic data has been obtained  
 AND DISPLAY Aircraft Summary  
 AND FORGET Flight and trim conditions have been obtained  
 AND FORGET Stability and control derivatives have been obtained  
 AND FORGET State matrix calculations have been obtained  
 AND FORGET Bare airframe dynamics have been obtained  
 AND FORGET Literal approximate factors have been obtained  
 AND FORGET Complete aircraft data has been obtained  
 AND FORGET Requirements must be set for the current case  
 AND FORGET Flight phase category  
 AND CHAIN C:\FCSXPRT\FLTCOND

!  
 !  
 !  
 !

---

Information Display Text

DISPLAY basic data read

Basic aircraft data, which is independent of flight condition, will now be read from file.

To continue, press F2

DISPLAY Aircraft Summary

The basic aircraft data, independent of flight condition, has been obtained for the [Degrees of freedom for control] of:

|                                   |                             |                       |                             |
|-----------------------------------|-----------------------------|-----------------------|-----------------------------|
| Aircraft                          | - [Aircraft designation]    |                       |                             |
| Type                              | - [Aircraft type]           |                       |                             |
| Mil-Spec Class                    | - [Aircraft classification] |                       |                             |
| Planform Area                     | - [Planform Area]           | Mean Aerodynamic Cord | - [Mean Aerodynamic Cord]   |
| Wing Span                         | - [Wing Span]               | Thrust Inclination    | - [Thrust Inclination]      |
| Weight                            | - [Weight]                  | X c.g. Mac            | - [X Center of Gravity Mac] |
| X Center of Gravity Gravity]      | - [X Center of Gravity]     | Y Center of Gravity   | - [Y Center of Gravity]     |
| Z Center of Gravity Inertia]      | - [Z Center of Gravity]     | X Moment of Inertia   | - [X Moment of Inertia]     |
| Y Moment of Inertia Inertia]      | - [Y Moment of Inertia]     | Z Moment of Inertia   | - [Z Moment of Inertia]     |
| XY Product of Inertia of Inertia] | - [XY Product of Inertia]   | XZ Product of Inertia | - [XZ Product of Inertia]   |
| YZ Product of Inertia             | - [YZ Product of Inertia]   |                       |                             |

Additional flight condition specific data, such as stability derivatives must now be obtained.

To specify the flight condition, press F2  
DISPLAY negative bandwidth

Bandwidth specifications must be POSITIVE numbers in radians/second.

To continue, press F2  
DISPLAY negative time delay

Effective time delays must be POSITIVE numbers in seconds.

To continue, press F2  
EXPAND Aircraft designation

Enter a name or designation for the aircraft.

To continue, press F8

!  
END

! "FLTCOND.PRL"

!

TITLE FLIGHT CONDITION DEFINITION {FLTCOND} DISPLAY

This expert assists in the definition of the flight condition and trim data needed for flight control system design. This includes obtaining all aircraft information, such as stability derivatives, which are functions of flight condition.

Note that any previously defined aircraft data, which is dependent on flight condition, will Not be retained.

To continue, press F3

SYSTEMS TECHNOLOGY, INC Hawthorne, CA  
Copyright (C) 1988

!.....

!

! Shared Facts Declarations

!

! The Shared Facts Declaration is stored in the "include" file named  
! "SHAREFCT.SHR" and combined with this knowledge base during compilation.

!

!

!\$SHAREFCT.SHR

!

!.....

!

! Data Type Declarations

!

!STRING St10

!

!.....

!

! Parameter Initialization Statements

!

INIT ZERO=0

AND ONE=1

AND TWO=2

AND FOUR=4

AND SIX=6

!

! String variables sent to DATOCC to create CC compatible files

```
! Name of directory where the BASIC file that will be converted resides
AND St1 := "C:\FCSDAT"
! Name of BASIC file to be converted to CC format
AND St2 := "BAREAC.SSM"
! Program CC filename
AND St3 := "$$P100"
```

```
! String variables sent to PROCALL program to activate an external program
```

```
! Subdirectory containing the external program
AND St7 := "C:\STI"
! Name of the external program
AND St8 := "CC.EXE"
! Parameters passed to external program
AND St15 := "@BAREAC.MAC,P100,H100"
```

```
REINIT ZERO=0
AND ONE=1
AND TWO=2
AND FOUR=4
AND SIX=6
```

```
!
! String variables sent to DATOCC to create CC compatible files
```

```
! Name of directory where the BASIC file that will be converted resides
AND St1 := "C:\FCSDAT"
! Name of BASIC file to be converted to CC format
AND St2 := "BAREAC.SSM"
! Program CC filename
AND St3 := "$$P100"
```

```
! String variables sent to PROCALL program to activate an external program
```

```
! Subdirectory containing the external program
AND St7 := "C:\STI"
! Name of the external program
AND St8 := "CC.EXE"
! Parameters passed to external program
AND St15 := "@BAREAC.MAC,P100,H100"
```

```
!.....
!  
! Control Element Selectors
```

```
THRESHOLD = 100
CONFIDENCE OFF
GOALSELECT ON
UNKNOWN CONTINUE
$EXHAUSTV.SHR
```

```

!.....
!
! Multiattributed Objects Declarations
!
! The "MULTI" Declaration of multivalued attribute is stored in the
! "include" file named "MULTI.SHR" and combined with this knowledge base
! during compilation.

```

\$MULTI.SHR

```

!.....
!
! Goal Outline
1. Flight and trim conditions have been obtained
  1.1 Stability and control derivatives have been obtained
    1.1.1 State matrix calculations have been obtained
      1.1.1.1 Bare airframe dynamics have been obtained
        1.1.1.1.1 Literal approximate factors have been obtained
          1.1.1.1.1.1 Requirements must be set for the current case

```

---

```

!
! Rules

```

```

RULE for reading flight and trim data file
IF Aircraft basic data has been obtained
AND DISPLAY flight condition data read
AND READ C:\FCSDAT\FLTCND.PRM
DATA Flight Condition
DATA Flight Phase
DATA Flight phase category literal
DATA Mach Number
DATA Altitude
DATA True Airspeed
DATA Wing Span
DATA Trim Angle of Attack
DATA Trim Angle of Sideslip
DATA Trim Heading
DATA Trim Pitch Attitude
DATA Trim Bank Angle
DATA Trim Flight Path Angle
DATA Trim Roll Rate
DATA Trim Pitch Rate
DATA Trim Yaw Rate
DATA Trim Turn Rate
DATA Trim Normal Load Factor
DATA Trim Lateral Load Factor
DATA Trim Axial Load Factor
THEN Flight and trim conditions have been obtained
AND Uo := (True Airspeed)*COS(Trim angle of attack/57.3)

```

```
ELSE DISPLAY no basic data
AND CHAIN C:\FCSXPRT\GENERATE
```

```
RULE for reading stability derivative data file
IF Flight and trim conditions have been obtained
AND DISPLAY derivative data read
AND READ C:\FCSDAT\DERIVS.PRM
```

```
DATA  $Y\beta$ 
DATA  $L\beta'$ 
DATA  $N\beta'$ 
DATA  $Lp'$ 
DATA  $Np'$ 
DATA  $Lr'$ 
DATA  $Nr'$ 
DATA  $Y\delta a\#$ 
DATA  $L\delta a'$ 
DATA  $N\delta a'$ 
DATA  $Y\delta r\#$ 
DATA  $L\delta r'$ 
DATA  $N\delta r'$ 
DATA  $Y\beta b$ 
DATA  $L\beta'b$ 
DATA  $N\beta'b$ 
DATA  $Lp'b$ 
DATA  $Np'b$ 
DATA  $Lr'b$ 
DATA  $Nr'b$ 
DATA  $Y\delta a\#b$ 
DATA  $L\delta a'b$ 
DATA  $N\delta a'b$ 
DATA  $Y\delta r\#b$ 
DATA  $L\delta r'b$ 
DATA  $N\delta r'b$ 
```

```
THEN Stability and control derivatives have been obtained
```

```
!
!
!
!
!
```

```
!       Defining the state matrix
```

```
RULE for defining bare airframe state matrix elements
IF Flight and trim conditions have been obtained
AND stability and control derivatives have been obtained
THEN State matrix calculations have been obtained
AND  $Y_v := Y\beta b / \text{True Airspeed}$ 
AND  $\alpha_{orad} := \text{Trim angle of attack} / 57.3$ 
AND  $\theta_{orad} := \text{Trim pitch attitude} / 57.3$ 
AND  $SIN\alpha_o := SIN(\alpha_{orad})$ 
AND  $NSIN\alpha_o := -SIN\alpha_o$ 
AND  $COS\alpha_o := COS(\alpha_{orad})$ 
AND  $NCOS\alpha_o := -COS\alpha_o$ 
AND  $GCOS\theta_o := 32.17 * COS(\theta_{orad}) / \text{True Airspeed}$ 
AND  $TAN\theta_o := TAN(\theta_{orad})$ 
```

```

!
!
RULE for obtaining bare airframe dynamics
IF Stability and control derivatives have been obtained
AND DISPLAY open loop dynamics data
AND WRITE C:\FCSDAT\BAREAC.SSM
DATA FOUR
DATA TWO
DATA TWO
DATA Yv
DATA SIN $\alpha_0$ 
DATA NCOS $\alpha_0$ 
DATA GCOS $\theta_0$ 
DATA Y $\delta a$ #b
DATA Y $\delta r$ #b
DATA L $\beta$ 'b
DATA L $p$ 'b
DATA L $r$ 'b
DATA ZERO
DATA L $\delta a$ 'b
DATA L $\delta r$ 'b
DATA N $\beta$ 'b
DATA N $p$ 'b
DATA N $r$ 'b
DATA ZERO
DATA N $\delta a$ 'b
DATA N $\delta r$ 'b
DATA ZERO
DATA ONE
DATA TAN $\theta_0$ 
DATA ZERO
DATA ZERO
DATA ZERO
DATA ZERO
DATA ONE
DATA ZERO
DATA ZERO
DATA ZERO
DATA ZERO
DATA ZERO
DATA ZERO
DATA ZERO
DATA ZERO
DATA ONE
DATA ZERO
DATA ZERO
DATA ZERO
!   The BASIC file "BAREAC.SSM" (St2) contains the bare airframe
!   state space model which will be transmitted to Program CC by DATOCC
!   and converted to a state space quadruple named "$$P100" (St3)
AND ACTIVATE C:\STI\DATOCC.EXE
SEND St1
SEND St2
SEND St7

```

```
SEND St3
AND ACTIVATE C:\STI\PROCALL.EXE
SEND St7
SEND St8
SEND St15
THEN Bare airframe dynamics have been obtained
AND bare airframe dutch roll damping ratio :- 0.10      !TEMPORARY
```

```
RULE for obtaining literal approximate factors
IF Bare airframe dynamics have been obtained
AND DISPLAY Literal approximate factors
AND FORGET Literal poles have been enumerated
AND FORGET Literal factors are defined for bare airframe poles
AND CHAIN C:\FCSXPRT\LITFAC
THEN Literal approximate factors have been obtained
```

```
RULE for setting requirements for the design case
IF Literal approximate factors have been obtained
!   AND DISPLAY requirement setup
THEN Complete aircraft data has been obtained
AND Requirements must be set for the current case
AND FORGET Dutch roll damping ratio spec is set
AND FORGET Dutch roll natural frequency spec is set
AND FORGET Dutch roll mode specs are set
AND FORGET Roll subsidence mode time constant spec is set
AND FORGET Roll subsidence mode specs are set
AND FORGET Dutch roll mode specs are set
AND FORGET Lateral directional specs are set
AND FORGET Requirements are set for the current' case
AND CHAIN C:\FCSXPRT\SPECSET
AND DISPLAY Aircraft Summary
```

```
!-----
!  
!   Information Display Text
```

DISPLAY no basic data

An aircraft and its basic data are not presently specified, so the flight condition specific data cannot be obtained yet.

To specify an aircraft, press F2  
DISPLAY flight condition data read

Flight condition and trim data will now be read from a file.

To continue, press F2



DISPLAY derivative data read

Flight Condition - [Flight Condition]  
 Flight Phase - [Flight Phase]  
 Flight phase category - [Flight phase category]

Mach Number - [Mach Number] Altitude - [Altitude]  
 True Airspeed - [True Airspeed] Wing Span - [Wing Span]  
 Trim Angle of Attack - [Trim Angle of Attack] Trim Angle of Sideslip - [Trim  
 Angle of Sideslip]  
 Trim Heading - [Trim Heading] Trim Pitch Attitude - [Trim Pitch  
 Attitude]  
 Trim Bank Angle - [Trim Bank Angle] Trim Flight Path Angle - [Trim Flight  
 Path Angle]  
 Trim Roll Rate - [Trim Roll Rate] Trim Pitch Rate - [Trim Pitch  
 Rate]  
 Trim Yaw Rate - [Trim Yaw Rate] Trim Turn Rate - [Trim Turn Rate]  
 Trim Normal Load Factor - [Trim Normal Load Factor] Trim Lateral Load Factor - [Trim  
 Lateral Load Factor]  
 Trim Axial Load Factor - [Trim Axial Load Factor]

Stability and control derivatives will now be read from a file.

To continue, press F2

DISPLAY open loop dynamics data

$Y\beta$  - [ $Y\beta(9,5)$ ]  $Y\beta b$  - [ $Y\beta b(9,5)$ ]  
 $L\beta'$  - [ $L\beta'(9,5)$ ]  $L\beta'b$  - [ $L\beta'b(9,5)$ ]  
 $N\beta'$  - [ $N\beta'(9,5)$ ]  $N\beta'b$  - [ $N\beta'b(9,5)$ ]  
 $Lp'$  - [ $Lp'(9,5)$ ]  $Lp'b$  - [ $Lp'b(9,5)$ ]  
 $Np'$  - [ $Np'(9,5)$ ]  $Np'b$  - [ $Np'b(9,5)$ ]  
 $Lr'$  - [ $Lr'(9,5)$ ]  $Lr'b$  - [ $Lr'b(9,5)$ ]  
 $Nr'$  - [ $Nr'(9,5)$ ]  $Nr'b$  - [ $Nr'b(9,5)$ ]  
 $Y\delta a^*$  - [ $Y\delta a^*(9,5)$ ]  $Y\delta a^*b$  - [ $Y\delta a^*b(9,5)$ ]  
 $L\delta a'$  - [ $L\delta a'(9,5)$ ]  $L\delta a'b$  - [ $L\delta a'b(9,5)$ ]  
 $N\delta a'$  - [ $N\delta a'(9,5)$ ]  $N\delta a'b$  - [ $N\delta a'b(9,5)$ ]  
 $Y\delta r'$  - [ $Y\delta r'(9,5)$ ]  $Y\delta r'b$  - [ $Y\delta r'b(9,5)$ ]  
 $L\delta r'$  - [ $L\delta r'(9,5)$ ]  $L\delta r'b$  - [ $L\delta r'b(9,5)$ ]  
 $N\delta r'$  - [ $N\delta r'(9,5)$ ]  $N\delta r'b$  - [ $N\delta r'b(9,5)$ ]

The open loop aircraft dynamics will now be computed.

To continue, press F2

DISPLAY Literal approximate factors

The literal approximate factors for the bare aircraft dynamics will now be obtained.

To continue, press F2

DISPLAY Aircraft Summary

AIRCRAFT SUMMARY

The flight condition and trim data and all necessary aircraft data have been obtained for the [Degrees of freedom for control] of:

|                |                           |
|----------------|---------------------------|
| Aircraft       | [Aircraft designation]    |
| Type           | [Aircraft type]           |
| Mil-Spec Class | [Aircraft classification] |

The design requirements will now be set for the current aircraft and flight condition.

To continue, press F2

!  
END

**LITFAC.PRL**

! "LITFAC.PRL"

!

! SYSTEMS TECHNOLOGY, INC Hawthorne, CA

TITLE Bare Airframe Literal Approximate Factors (LITFAC) DISPLAY

This expert formulates literal approximate factors for poles and zeros of the bare airframe.

To continue, press F3

!.....

!

! Shared Facts Declarations

!

! The Shared Facts Declaration is stored in the "include" file named "SHAREFCT.SHR" and combined with this knowledge base during compilation.

!

\$SHAREFCT.SHR

!

!.....

!

Data Type Declarations

!

!.....

!

Parameter Initialization Statements

!

!.....

!

Control Element Selectors

THRESHOLD - 60

CONFIDENCE OFF

GOALSELECT ON

UNKNOWN CONTINUE

\$EXHAUSTV.SHR

!.....

!

Multiattributed Objects Declarations

!

! The "MULTI" Declaration of multiattributed objects is stored in the "include" file named "MULTI.SHR" and combined with this knowledge base during compilation.

!

\$MULTI.SHR

!.....

!

! Goal Outline

1. Literal poles have been enumerated
  - 1.1 Literal factors are defined

!  
!  
!  
!  
!  
!  
!  
!

Rules

.....

RULE for initial literal parameters  
Wrs\$abs := SQRT(ABS((g/Uo)\*(Nr'\*Lβ'/Nβ' - Lr')))  
Wd\$abs := SQRT(ABS(Nβ'))  
ZWrs\$abs := ABS(-Lp'+(Lβ'/Nβ')\*(Np'-g/Uo))/2  
ZWd\$abs := ABS(-(Yv+Nr')-(Lβ'/Nβ')\*(Np'-g/Uo))/2  
IF Bare airframe dynamics have been obtained  
THEN Initial literal parameters have been calculated  
AND Zrs\$abs := ZWrs\$abs/Wrs\$abs  
AND Zd\$abs := ZWd\$abs/Wd\$abs

RULE for literal roll spiral mode complexity  
IF Initial literal parameters have been calculated  
AND Zrs\$abs < 1  
THEN Literal roll spiral mode complexity IS complex  
ELSE Literal roll spiral mode complexity IS real

RULE for literal dutch roll mode complexity  
IF Initial literal parameters have been calculated  
AND Zd\$abs < 1  
THEN Literal dutch roll mode complexity IS complex  
ELSE Literal dutch roll mode complexity IS real

RULE for number of real poles  
IF Literal roll spiral mode complexity IS complex  
AND Literal dutch roll mode complexity IS complex  
THEN Literal poles have been enumerated  
AND Number of literal real poles := 0  
AND Number of literal complex pole pairs := 2  
AND Literal roll spiral coupling exists

RULE for number of real roots  
IF Literal roll spiral mode complexity IS real  
AND Literal dutch roll mode complexity IS complex  
THEN Literal poles have been enumerated  
AND Number of literal real poles := 2  
AND Number of literal complex pole pairs := 1

RULE for number of real roots  
IF Literal roll spiral mode complexity IS complex  
AND Literal dutch roll mode complexity IS real

THEN Literal poles have been enumerated  
AND Number of literal real poles := 0  
AND Number of literal complex pole pairs := 1  
AND Literal roll spiral coupling exists

RULE for number of real roots  
IF Literal roll spiral mode complexity IS real  
AND Literal dutch roll mode complexity IS real  
THEN Literal poles have been enumerated  
AND Number of literal real poles := 4  
AND Number of literal complex pole pairs := 0

RULE for standard literal factors  
IF Literal roll spiral mode complexity IS real  
AND Literal dutch roll mode complexity IS complex  
THEN Literal factors are defined for bare airframe poles  
AND ITr\$ :=  $-Lp' + (L\beta' / N\beta') * (Np' - g/Uo)$   
AND ITs\$ :=  $(g/Uo) * (Nr' * L\beta' / N\beta' - Lr') / ITr\$$   
AND Wd\$ :=  $SQRT(N\beta')$   
AND ZWd\$ :=  $(-(Yv + Nr') - (L\beta' / N\beta') * (Np' - g/Uo)) / 2$   
AND Zd\$ :=  $ZWd\$ / Wd\$$   
AND DISPLAY Literal factor summary 1

RULE for initiating bare airframe pole identification  
IF Literal factors are defined for bare airframe poles  
THEN Literal factors are defined  
AND CHAIN C:\FCSXPRT\BAROOTID.PRL

!  
!  
! Information Display Text

DISPLAY Literal factor summary 1

#### RESULTS FROM LITERAL APPROXIMATE FACTORS

Roll spiral mode is [Literal roll spiral mode complexity]  
Dutch roll mode is [Literal dutch roll mode complexity]

|  |                |         |
|--|----------------|---------|
| Spiral mode inverse time constant          | = [ITs\$(9,5)] | rad sec |
| Roll subsidence mode inverse time constant | = [ITr\$(7,3)] | rad sec |
| Dutch roll damping ratio                   | = [Zd\$(8,4)]  |         |
| Dutch roll undamped natural frequency      | = [Wd\$(6,2)]  | rad sec |

To continue, press F2

!  
END

**BAROOTID.PRL**

! "BAROOTID.PRL"

!

! SYSTEMS TECHNOLOGY, INC Hawthorne, CA

TITLE Bare Airframe Pole and Zero Identification {BAROOTID} DISPLAY

This expert manages the physical identification of the poles and zeros of the bare airframe.

To continue, press F3

!.....

!

! Shared Facts Declarations

!

! The Shared Facts Declaration is stored in the "include" file named "SHAREFCT.SHR" and combined with this knowledge base during compilation.

!

!\$SHAREFCT.SHR

!

!.....

!

! Data Type Declarations

!

- NUMERIC Number of numerical real zeros
- AND Number of numerical complex zero pairs
- AND Number of numerical real poles
- AND Number of numerical complex pole pairs
- AND Number of nonminimum phase numerical real zeros
- AND Number of nonminimum phase numerical complex zero pairs
- AND Number of unstable numerical real poles
- AND Number of unstable numerical complex pole pairs
- AND High frequency gain
- AND Inverse time constant of real zero #1
- AND Inverse time constant of real zero #2
- AND Inverse time constant of real zero #3
- AND Inverse time constant of real zero #4
- AND Inverse time constant of real zero #5
- AND Inverse time constant of real zero #6
- AND Damping ratio of complex zero pair #1
- AND Natural frequency of complex zero pair #1
- AND Damping ratio of complex zero pair #2
- AND natural frequency of complex zero pair #2
- AND Damping ratio of complex zero pair #3
- AND natural frequency of complex zero pair #3
- AND Damping ratio of complex zero pair #4
- AND natural frequency of complex zero pair #4
- AND Damping ratio of complex zero pair #5
- AND natural frequency of complex zero pair #5
- AND Damping ratio of complex zero pair #6



```

AND natural frequency of complex zero pair #6
AND Inverse time constant of real pole #1
AND Inverse time constant of real pole #2
AND Inverse time constant of real pole #3
AND Inverse time constant of real pole #4
AND Inverse time constant of real pole #5
AND Inverse time constant of real pole #6
AND Damping ratio of complex pole pair #1
AND natural frequency of complex pole pair #1
AND Damping ratio of complex pole pair #2
AND natural frequency of complex pole pair #2
AND Damping ratio of complex pole pair #3
AND natural frequency of complex pole pair #3
AND Damping ratio of complex pole pair #4
AND natural frequency of complex pole pair #4
AND Damping ratio of complex pole pair #5
AND natural frequency of complex pole pair #5
AND Damping ratio of complex pole pair #6
AND natural frequency of complex pole pair #6
AND Inverse time constant of bare airframe real pole #1
AND Inverse time constant of bare airframe real pole #2
AND Damping ratio of bare airframe complex pole pair #1
AND Natural frequency of bare airframe complex pole pair #1

```

```

STRING St7
AND St8
AND St15
AND St35
AND St36
AND St37

```

```

!.....
!
!   Parameter Initialization Statements
!
!   String variables sent to PROCALL program to activate an external program
!
!   Subdirectory containing the external program
INIT St7 := "C:\STI"
!   Name of the external program
AND St8 := "CC.EXE"
!   Macro parameters passed to Program CC
AND St15 := "@BAPDA.MAC,H100,G10011"
!
!   String variables sent to program "TFCCL5"
!
AND St35 := "C:\STI\$$"
!   Name of pb|δa file in Program CC format
AND St36 := "G10011"
!   Name of pb|δa file in LEVEL 5 format output by TFCCL5
AND St37 := "C:\FCSDAT\BAPDA.PRM"

```

```

! Subdirectory containing the external program
REINIT St7 := "C:\STI"
! Name of the external program
AND St8 := "CC.EXE"
! Macro parameters passed to Program CC
AND St15 := "@BAPDA.MAC,H100,G10011"
!
! String variables sent to program "TFCCL5"
!
AND St35 := "C:\STI\$$"
! Name of pb|δa file in Program CC format
AND St36 := "G10011"
! Name of pb|δa file in LEVEL 5 format output by TFCCL5
AND St37 := "C:\FCSDAT\BAPDA.PRM"

```

```

!.....
!
! Control Element Selectors

```

```

THRESHOLD - 60
CONFIDENCE OFF
GOALSELECT ON
UNKNOWN CONTINUE
$EXHAUSTV.SHR

```

```

!.....
!
! Multiattributed Objects Declarations
!
! The "MULTI" Declaration of multiattributed objects is stored in the
! "include" file named "MULTI.SHR" and combined with this knowledge base
! during compilation.

```

```

$MULTI.SHR

```

```

!.....
!
! Goal Outline

```

1. Generic bare airframe poles are defined
  - 1.1 Bare airframe poles are identified

```

!-----
!
! Rules
!
!.....

```

```

RULE for extracting pb|δa
! Executes macro "BAPDA" in Program CC which extracts the pb|δa transfer
! function from the bare airframe transfer function matrix (element (1,1)
! in H100) and stores it in file "$$g10011".

```

```

IF Literal factors are defined
AND ACTIVATE C:\STI\PROCALL.EXE
SEND St7 ! St7 := "C:\STI", Subdirectory containing external program (CC)
SEND St8 ! St8 := "CC.EXE", Name of the external program
SEND St15 ! St15 := "@BAPDA.MAC", Macro parameters passed to Program CC
THEN Bare airframe pb| $\delta$ a has been generated

RULE for reading bare airframe pb| $\delta$ a
! Activates program "TFCCL5" to convert bare airframe pb| $\delta$ a (in Program CC
! file $$g10011) to LEVEL 5 format stored in file BAPDA.PRM. This file is
! then read into the knowledge base.
IF Bare airframe pb| $\delta$ a has been generated
AND ACTIVATE C:\STI\TFCCL5.EXE
SEND St35
SEND St36 ! St36 := "G10011", pb| $\delta$ a file in Program CC format
SEND St37 ! St37 := "C:\FCSDAT\BAPDA.PRM", pb| $\delta$ a file in LEVEL 5 format
THEN Bare airframe identification transfer function has been read
! File BAPDA.PRM contains a transfer function in a format readable by LEVEL 5
! Zeros and poles are listed in order of increasing frequency
AND READ C:\FCSDAT\BAPDA.PRM
DATA Number of numerical real zeros
DATA Number of numerical complex zero pairs
DATA Number of numerical real poles
DATA Number of numerical complex pole pairs
DATA Number of nonminimum phase numerical real zeros
DATA Number of nonminimum phase numerical complex zero pairs
DATA Number of unstable numerical real poles
DATA Number of unstable numerical complex pole pairs
DATA High frequency gain
DATA Inverse time constant of real zero #1
DATA Inverse time constant of real zero #2
DATA Inverse time constant of real zero #3
DATA Inverse time constant of real zero #4
DATA Inverse time constant of real zero #5
DATA Inverse time constant of real zero #6
DATA Damping ratio of complex zero pair #1
DATA natural frequency of complex zero pair #1
DATA Damping ratio of complex zero pair #2
DATA natural frequency of complex zero pair #2
DATA Damping ratio of complex zero pair #3
DATA natural frequency of complex zero pair #3
DATA Damping ratio of complex zero pair #4
DATA natural frequency of complex zero pair #4
DATA Damping ratio of complex zero pair #5
DATA natural frequency of complex zero pair #5
DATA Damping ratio of complex zero pair #6
DATA natural frequency of complex zero pair #6
DATA Inverse time constant of real pole #1
DATA Inverse time constant of real pole #2
DATA Inverse time constant of real pole #3
DATA Inverse time constant of real pole #4
DATA Inverse time constant of real pole #5

```

DATA Inverse time constant of real pole #6  
DATA Damping ratio of complex pole pair #1  
DATA natural frequency of complex pole pair #1  
DATA Damping ratio of complex pole pair #2  
DATA natural frequency of complex pole pair #2  
DATA Damping ratio of complex pole pair #3  
DATA natural frequency of complex pole pair #3  
DATA Damping ratio of complex pole pair #4  
DATA natural frequency of complex pole pair #4  
DATA Damping ratio of complex pole pair #5  
DATA natural frequency of complex pole pair #5  
DATA Damping ratio of complex pole pair #6  
DATA natural frequency of complex pole pair #6  
AND DISPLAY TF data

RULE for standard generic bare airframe poles  
IF Bare airframe identification transfer function has been read  
AND Number of numerical real poles = 2  
THEN Generic bare airframe poles are defined  
AND Number of bare airframe numerical real poles := Number of numerical real poles  
AND Number of bare airframe numerical complex pole pairs := Number of numerical complex pole pairs  
AND Inverse time constant of bare airframe real pole #1 := Inverse time constant of real pole #1  
AND Inverse time constant of bare airframe real pole #2 := Inverse time constant of real pole #2  
AND Damping ratio of bare airframe complex pole pair #1 := Damping ratio of complex pole pair #1  
AND natural frequency of bare airframe complex pole pair #1 := natural frequency of complex pole pair #1

RULE for physically possible bare airframe real poles  
IF Number of bare airframe numerical real poles = 0  
OR Number of bare airframe numerical real poles = 2  
OR Number of bare airframe numerical real poles = 4  
THEN Bare airframe real poles are feasible  
ELSE NOT Bare airframe real poles are feasible

RULE for physically possible bare airframe complex poles  
IF Number of bare airframe numerical complex pole pairs = 0  
OR Number of bare airframe numerical complex pole pairs = 1  
OR Number of bare airframe numerical complex pole pairs = 2  
THEN Bare airframe complex poles are feasible  
ELSE NOT Bare airframe complex poles are feasible

RULE for physically possible bare airframe poles  
IF Bare airframe real poles are feasible  
AND Bare airframe complex poles are feasible  
THEN Bare airframe poles are feasible  
ELSE NOT Bare airframe poles are feasible  
AND DISPLAY Impossible poles

RULE for literal approximate pole factor validity check #2  
IF Bare airframe poles are feasible  
AND Number of literal real poles = Number of numerical real poles  
THEN Literal poles are valid at check #2

RULE for standard poles  
IF Literal poles are valid at check #2  
AND Literal roll spiral mode complexity IS real  
AND Literal dutch roll mode complexity IS complex  
THEN Bare airframe poles are tentatively identified  
AND ITs := Inverse time constant of bare airframe real pole #1  
AND ITr := Inverse time constant of bare airframe real pole #2  
AND Zd := Damping ratio of bare airframe complex pole pair #1  
AND Wd := natural frequency of bare airframe complex pole pair #1

RULE for literal approximate pole factor validity check #3  
IF Bare airframe poles are tentatively identified  
AND Literal roll spiral mode complexity IS real  
AND Literal dutch roll mode complexity IS complex  
AND ABS(1-ABS(ITs/ITs\$)) < 0.2  
AND ABS(1-ABS(ITr/ITr\$)) < 0.2  
AND ABS(1-ABS(Zd/Zd\$)) < 0.25  
AND ABS(1-ABS(Wd/Wd\$)) < 0.2  
THEN Literal poles are valid at check #3  
AND DISPLAY Pole summary 1

RULE for returning to calling expert  
IF Literal poles are valid at check #3  
THEN Bare airframe poles are identified  
AND Literal approximate factors have been obtained  
AND CHAIN C:\FCSXPRT\FLTCOND  
ELSE NOT Literal approximate factors have been obtained

!-----!  
!  
! Information Display Text

DISPLAY Impossible poles

The bare airframe dynamics calculations have resulted in [Number of bare airframe numerical real poles] real poles and [Number of bare airframe numerical complex pole pairs] complex pole pairs which is physically impossible.

To continue, press F2

DISPLAY Pole summary 1

IDENTIFIED BARE AIRFRAME POLES FROM NUMERICAL FACTORING

Roll spiral mode is [Literal roll spiral mode complexity]  
Dutch roll mode is [Literal dutch roll mode complexity]

Spiral mode inverse time constant - [ITs(9,5)] rad|sec  
Roll subsidence mode inverse time constant - [ITr(7,3)] rad|sec  
Dutch roll damping ratio - [Zd(8,4)]  
Dutch roll undamped natural frequency - [Wd(6,2)] rad|sec

To continue, press F2

DISPLAY TF data

Number of real zeros - [Number of numerical real zeros]  
Number of complex zero pairs - [Number of numerical complex zero pairs]  
Number of real poles - [Number of numerical real poles]  
Number of complex poles - [Number of numerical complex pole pairs]  
Number of nonminimum phase real zeros - [Number of nonminimum phase numerical real zeros]  
Number of nonminimum phase complex zero - [Number of nonminimum phase numerical complex zero pairs]  
Number of unstable real poles - [Number of unstable numerical real poles]  
Number of unstable complex poles - [Number of unstable numerical complex pole pairs]  
High frequency gain - [High frequency gain]

Zeros:

Real - [Inverse time constant of real zero #1]  
Real - [Inverse time constant of real zero #2]  
Real - [Inverse time constant of real zero #3]  
Real - [Inverse time constant of real zero #4]  
Real - [Inverse time constant of real zero #5]  
Real - [Inverse time constant of real zero #6]

Damping ratio - [Damping ratio of complex zero pair #1]  
Frequency - [natural frequency of complex zero pair #1]  
Damping ratio - [Damping ratio of complex zero pair #2]  
Frequency - [natural frequency of complex zero pair #2]  
Damping ratio - [Damping ratio of complex zero pair #3]  
Frequency - [natural frequency of complex zero pair #3]  
Damping ratio - [Damping ratio of complex zero pair #4]  
Frequency - [natural frequency of complex zero pair #4]  
Damping ratio - [Damping ratio of complex zero pair #5]  
Frequency - [natural frequency of complex zero pair #5]  
Damping ratio - [Damping ratio of complex zero pair #6]  
Frequency - [natural frequency of complex zero pair #6]

Poles:

Real - [Inverse time constant of real pole #1]  
Real - [Inverse time constant of real pole #2]  
Real - [Inverse time constant of real pole #3]  
Real - [Inverse time constant of real pole #4]

Real - [Inverse time constant of real pole #5]  
Real - [Inverse time constant of real pole #6]

Damping ratio - [Damping ratio of complex pole pair #1]  
Frequency - [natural frequency of complex pole pair #1]  
Damping ratio - [Damping ratio of complex pole pair #2]  
Frequency - [natural frequency of complex pole pair #2]  
Damping ratio - [Damping ratio of complex pole pair #3]  
Frequency - [natural frequency of complex pole pair #3]  
Damping ratio - [Damping ratio of complex pole pair #4]  
Frequency - [natural frequency of complex pole pair #4]  
Damping ratio - [Damping ratio of complex pole pair #5]  
Frequency - [natural frequency of complex pole pair #5]  
Damping ratio - [Damping ratio of complex pole pair #6]  
Frequency - [natural frequency of complex pole pair #6]  
!  
END

**SPECSET.PRL**



! "SPECSET.PRL"

!

TITLE AIRCRAFT DYNAMICS REQUIREMENTS SETUP (SPECSET) DISPLAY

This expert assists in setting up design requirements appropriate to the aircraft and flight condition.

To continue, PRESS F3

!.....

!

! Shared Facts Declarations

!

! The Shared Facts Declaration is stored in the "include" file named  
! "SHAREFCT.SHR" and combined with this knowledge base during compilation.

!

!\$SHAREFCT.SHR

!

!.....

!

!

! Data Type Declarations

!

!.....

!

! Parameter Initialization Statements

!

!.....

!

! Control Element Selectors

!

!THRESHOLD = 100

!CONFIDENCE OFF

!GOALSELECT ON

!UNKNOWN CONTINUE

!\$EXHAUSTV.SHR

!

!.....

!

! Multiattributed Objects Declarations

!

! The "MULTI" Declaration of multiattributed objects is stored in the  
! "include" file named "MULTI.SHR" and combined with this knowledge base  
! during compilation.

!

!\$MULTI.SHR

!

!.....

!

!  
! Goal Outline  
!  
!  
1. requirements are set for the current case  
!

---

! Rules

RULE for setting dutch roll damping ratio spec  
IF Aircraft classification IS Class IV  
AND Flight phase category IS Category CO  
THEN Dutch roll damping ratio spec is set  
AND Dutch roll damping ratio spec := 0.35

RULE for dutch roll mode specs  
IF Dutch roll damping ratio spec is set  
! AND Dutch roll natural frequency spec is set  
THEN Dutch roll mode specs are set

RULE for setting roll subsidence mode time constant  
IF Aircraft classification IS Class IV  
AND Flight phase category IS Category CO  
THEN Roll subsidence mode time constant spec is set  
AND Roll subsidence mode time constant spec := 1.0

RULE for roll subsidence mode specs  
IF Roll subsidence mode time constant spec is set  
THEN Roll subsidence mode specs are set

RULE for lateral directional specs  
IF Roll subsidence mode specs are set  
AND Dutch roll mode specs are set  
THEN Lateral directional specs are set

RULE for determining if specs are set  
IF Lateral directional specs are set  
THEN Requirements are set for the current case  
AND DISPLAY spec setup  
AND FORGET open loop aircraft model is setup  
AND FORGET open loop aircraft dynamics have been obtained  
AND FORGET open loop aircraft poles and zeros have been identified  
AND FORGET open loop aircraft spec comparison is complete  
AND FORGET open loop aircraft dynamics are adequate  
AND FORGET open loop aircraft assessment is complete  
AND CHAIN C:\FCSXPRT\ASSESSOL

---

!  
!  
! Information Display Text

DISPLAY spec setup

The general requirements and specifications have been specialized to the current aircraft and flight conditions.

The open loop aircraft specifications must now be assessed with respect to these requirements.

To continue, press F2

!  
END

**ASSESSOL.PRL**

! "ASSESSOL.PRL"

!

TITLE Open Loop Aircraft Assessment (ASSESSOL) DISPLAY

This expert assists in the assessment of the open loop aircraft dynamics.

To continue, PRESS F3

!.....

!

! Shared Facts Declarations

!

! The Shared Facts Declaration is stored in the "include" file named "SHAREFCT.SHR" and combined with this knowledge base during compilation.

!

!\$SHAREFCT.SHR

!

!.....

!

! Data Type Declarations

!

!.....

!

! Parameter Initialization Statements

!

INIT St7 := "C:\STI" ! Subdirectory where PROGRAM CC resides
AND St8 := "CC.EXE" ! PROGRAM CC calling syntax
AND St16 := "@OLAIRPLN.MAC" ! Parameter to be passed to PROGRAM CC
REINIT St7 := "C:\STI" ! Subdirectory where PROGRAM CC resides
AND St8 := "CC.EXE" ! PROGRAM CC calling syntax
AND St16 := "@OLAIRPLN.MAC" ! Parameter to be passed to PROGRAM CC

!.....

!

! Control Element Selectors

THRESHOLD = 100
CONFIDENCE OFF
GOALSELECT ON
UNKNOWN CONTINUE
\$EXHAUSTV.SHR

!.....

!

! Multiattributed Objects Declarations

!

! The "MULTI" Declaration of multiattributed objects is stored in the "include" file named "MULTI.SHR" and combined with this knowledge base during compilation.

!

```

!
$MULTI.SHR
!
!.....
!
!   Goal Outline
!
1.  open loop aircraft assessment is complete
!
!.....
!
!   Rules
!
RULE for generating open loop aircraft dynamics
IF Complete aircraft data has been obtained
!
!
!       Calling external program
!
!
AND ACTIVATE C:\STI\PROCALL.EXE
SEND St7           ! Subdirectory where the program resides
SEND St8           ! Program that will be called by Level 5
SEND St16          ! Parameter to be passed to program
!
!
!
THEN open loop aircraft dynamics have been obtained
AND DISPLAY dynamic characteristics

RULE for assessing the open loop dynamics
IF open loop aircraft dynamics have been obtained
AND FORGET bare airframe dutch roll damping ratio has been assessed
AND FORGET bare airframe dutch roll mode dynamics are adequate
AND FORGET bare airframe dutch roll mode has been assessed
AND FORGET bare airframe roll mode time constant has been assessed
AND FORGET bare airframe roll subsidence mode dynamics are adequate
AND FORGET bare airframe roll subsidence mode has been assessed
AND FORGET bare airframe spiral mode dynamics are adequate
AND FORGET open loop aircraft dynamics are adequate
AND FORGET system has been compared with the specifications
AND FORGET open loop aircraft spec comparison is complete
AND FORGET bare airframe dutch roll damping ratio assessment
AND FORGET bare airframe dutch roll natural frequency
AND FORGET bare airframe roll subsidence mode time constant assessment
AND CHAIN C:\FCSXPRT\SPECHKOL
THEN open loop aircraft spec comparison is complete
AND DISPLAY dynamics assessment

RULE for treating an inadequate airframe
IF open loop aircraft spec comparison is complete
AND NOT open loop aircraft dynamics are adequate

```

THEN open loop aircraft assessment is complete  
AND DISPLAY Airframe Summary  
AND FORGET yaw damper is a candidate loop  
AND FORGET roll damper is a candidate loop  
AND FORGET sideslip to rudder is a candidate loop  
AND FORGET lateral acceleration to rudder is a candidate loop  
AND FORGET pitch rate to elevator is a candidate loop  
AND FORGET candidate loops have been identified  
AND FORGET Candidate loops have been reported  
AND FORGET candidate architectures have been identified  
AND FORGET RD&YD is a candidate architecture  
AND FORGET RD&B\_DR is a candidate architecture  
AND FORGET RD&AY\_DR is a candidate architecture  
AND FORGET Candidate architectures have been ranked  
AND FORGET Prospectus for control has been defined  
AND CHAIN C:\FCSXPRT\PRSPCTUS

RULE for announcing an adequate airframe  
IF open loop aircraft spec comparison is complete  
AND open loop aircraft dynamics are adequate  
THEN open loop aircraft assessment is complete  
AND DISPLAY Airframe Summary  
AND CHAIN C:\FCSXPRT\GENERATE

!

!

!

! Information Display Text

!

DISPLAY dynamic characteristics

The dynamics characteristics have been obtained for the system

To continue, Press F2

!

DISPLAY poles and zeros

!

The poles and zeros have been identified as follows:

!

To continue, Press F2

DISPLAY dynamics assessment

The assessment of the system dynamics indicates the following problems:

To continue, Press F2

!

DISPLAY dynamics diagnosis

!

The diagnosis of the systems problems indicates that:

!  
DISPLAY Airframe Summary

To continue, Press F2

The open loop aircraft has been assessed and:

the dynamics are adequate - [open loop aircraft dynamics are adequate]

To continue, press F2

END



**SPECHKOL.PRL**

! "SPECHKOL.PRL"

!

TITLE BARE AIRCRAFT DYNAMICS SPECIFICATION CHECKER {SPECHKOL} DISPLAY

This expert assists in comparing the open loop aircraft to the appropriate design requirements.

To continue, PRESS F3

!.....

!

! Shared Facts Declarations

!

! The Shared Facts Declaration is stored in the "include" file named  
! "SHAREFCT.SHR" and combined with this knowledge base during compilation.

!

! \$SHAREFCT.SHR

!

!.....

!

! Data Type Declarations

!

!.....

!

! Parameter Initialization Statements

!

!.....

!

! Control Element Selectors

THRESHOLD - 100

CONFIDENCE OFF

GOALSELECT ON

UNKNOWN CONTINUE

\$EXHAUSTV.SHR

!.....

!

! Multiattributed Objects Declarations

!

! The "MULTI" Declaration of multiattributed objects is stored in the  
! "include" file named "MULTI.SHR" and combined with this knowledge base  
! during compilation.

!

! \$MULTI.SHR

!

!.....

!

!

! Goal Outline

!  
!  
! 1. open loop aircraft spec comparison is complete

!  
! Rules

! RULE for assessing bare airframe dutch roll damping ratio  
! IF  $Z_d \geq$  dutch roll damping ratio spec  
! THEN bare airframe dutch roll damping ratio assessment IS adequate  
! AND bare airframe dutch roll damping ratio has been assessed  
! ELSE bare airframe dutch roll damping ratio assessment IS too low  
! AND bare airframe dutch roll damping ratio has been assessed

! RULE for assessing bare airframe dutch roll mode  
! IF bare airframe dutch roll damping ratio assessment IS adequate  
! AND bare airframe dutch roll natural frequency IS adequate  
! THEN bare airframe dutch roll mode dynamics are adequate  
! AND bare airframe dutch roll mode has been assessed  
! ELSE NOT bare airframe dutch roll mode dynamics are adequate  
! AND bare airframe dutch roll mode has been assessed

! RULE for assessing bare airframe roll subsidence mode  
! IF  $I_{Tr} \geq 1/(\text{Roll subsidence mode time constant spec})$   
! THEN bare airframe roll mode time constant assessment IS adequate  
! AND bare airframe roll mode time constant has been assessed  
! ELSE bare airframe roll mode time constant assessment IS too high  
! AND bare airframe roll mode time constant has been assessed

! RULE for assessing bare airframe roll subsidence mode  
! IF bare airframe roll mode time constant assessment IS adequate  
! THEN bare airframe roll subsidence mode dynamics are adequate  
! AND bare airframe roll subsidence mode has been assessed  
! ELSE NOT bare airframe roll subsidence mode dynamics are adequate  
! AND bare airframe roll subsidence mode has been assessed

! RULE for assessing bare airframe modal characteristics  
! IF bare airframe dutch roll mode dynamics are adequate  
! AND bare airframe roll subsidence mode dynamics are adequate  
! AND bare airframe spiral mode dynamics are adequate  
! THEN open loop aircraft dynamics are adequate  
! AND system has been compared with the specifications

! RULE for assessing bare airframe modal characteristics  
! IF bare airframe dutch roll mode dynamics are adequate  
! AND NOT bare airframe roll subsidence mode dynamics are adequate  
! AND bare airframe spiral mode dynamics are adequate  
! THEN NOT open loop aircraft dynamics are adequate  
! AND system has been compared with the specifications

RULE for assessing bare airframe modal characteristics  
IF NOT bare airframe dutch roll mode dynamics are adequate  
AND bare airframe roll subsidence mode dynamics are adequate  
! AND bare airframe spiral mode dynamics are adequate  
THEN NOT open loop aircraft dynamics are adequate  
AND system has been compared with the specifications

RULE for assessing bare airframe modal characteristics  
IF NOT bare airframe dutch roll mode dynamics are adequate  
AND NOT bare airframe roll subsidence mode dynamics are adequate  
! AND bare airframe spiral mode dynamics are adequate  
THEN NOT open loop aircraft dynamics are adequate  
AND system has been compared with the specifications

RULE for determining if spec comparison has been completed  
IF system has been compared with the specifications  
THEN open loop aircraft spec comparison is complete  
AND DISPLAY spec comparison results  
AND CHAIN C:\FCSXPRT\ASSESSOL

!  
!-----!  
!  
! Information Display Text  
!  
DISPLAY spec comparison results

Comparison of the system with the requirements indicates that bare airframe

Dutch roll damping ratio is: [bare airframe dutch roll damping ratio assessment]  
Roll subsidence mode is: [bare airframe roll mode time constant assessment]

Therefore, it is [open loop aircraft dynamics are adequate] that the  
bare airframe modal dynamics are adequate.

To continue, press F2

END

**PRSPCTUS.PRL**

!"PRSPCTUS.PRL"

TITLE FCS Prospectus Expert (PRSPCTUS) DISPLAY

This Expert assists in definition of candidate loops that are likely to be useful in the FCS design and combines these loops into recommended architectures ranked by their potential for the current case.

To continue, press F3

! .....  
!  
! Shared Facts Declarations  
!  
! The Shared Facts Declaration is stored in the "include" file named  
! "SHAREFCT.SHR" and combined with this knowledge base during compilation.  
!

\$SHAREFCT.SHR

! .....  
!  
! Data Type Declarations  
! .....  
!  
! Parameter Initialization Statements  
! .....  
!  
! Control Element Selectors

THRESHOLD - 100  
CONFIDENCE OFF  
GOALSELECT ON  
UNKNOWN CONTINUE  
\$EXHAUSTV.SHR

! .....  
!  
! Multiattributed Objects Declarations  
!  
! The "MULTI" Declaration of multiattributed objects is stored in the  
! "include" file named "MULTI.SHR" and combined with this knowledge base  
! during compilation.

\$MULTI.SHR

! .....  
!  
! Goal Outline

1. Candidate loops have been reported
  - 1.1 Candidate architectures have been identified
    - 1.1.1 Prospectus for control has been defined

!  
!  
!  
!  
!  
!  
!  
!

Rules

Rules for identifying candidate loops based on bare airframe deficiencies

RULE for roll damper loop candidacy  
 IF bare airframe roll mode time constant assessment IS too high  
 OR yaw damper is a candidate loop  
 THEN candidate loops have been identified  
 AND roll damper is a candidate loop

RULE for yaw damper loop candidacy  
 IF bare airframe dutch roll damping ratio assessment IS too low  
 THEN candidate loops have been identified  
 AND yaw damper is a candidate loop  
 AND sideslip to rudder is a candidate loop  
 AND lateral acceleration to rudder is a candidate loop

RULE for reporting candidate loops  
 IF candidate loops have been identified  
 THEN Candidate loops have been reported  
 AND DISPLAY Candidate loops

!  
!  
!

Rules for identifying candidate architectures

RULE for RD&YD architecture candidacy  
 IF Degrees of freedom for control ARE lateral directional axes  
 AND roll damper is a candidate loop  
 AND yaw damper is a candidate loop  
 THEN candidate architectures have been identified  
 AND RD&YD is a candidate architecture

RULE for RD&B\_DR architecture candidacy  
 IF Degrees of freedom for control ARE lateral directional axes  
 AND roll damper is a candidate loop  
 AND sideslip to rudder is a candidate loop  
 THEN candidate architectures have been identified  
 AND RD&B\_DR is a candidate architecture

RULE for RD&AY\_DR architecture candidacy  
 IF Degrees of freedom for control ARE lateral directional axes  
 AND roll damper is a candidate loop

AND lateral acceleration to rudder is a candidate loop  
THEN candidate architectures have been identified  
AND RD&AY\_DR is a candidate architecture

!.....  
!  
! Rules for ranking candidate architectures by the order in which  
! they should be considered.

RULE for RD&YD architecture consideration ranking  
IF Degrees of freedom for control ARE lateral directional axes  
AND RD&YD is a candidate architecture  
AND RD&B\_DR is a candidate architecture  
AND RD&AY\_DR is a candidate architecture  
THEN Candidate architectures have been ranked  
AND First architecture for consideration IS RD&YD  
AND Second architecture for consideration IS RD&B\_DR  
AND Third architecture for consideration IS RD&AY\_DR

RULE for reporting candidate architecture rankings  
IF Candidate architectures have been ranked  
THEN Prospectus for control has been defined  
AND CHAIN C:\FCSXPRT\GENERATE  
AND DISPLAY Candidate architectures

!-----  
!  
! Information Display Text

DISPLAY Candidate Loops

CANDIDATE FCS LOOPS

The candidate loops potentially useful for the control of the  
[Degrees of freedom for control] of this (aircraft type) have been  
identified and include:

| Loop               | Potentially useful ?                                 |
|--------------------|--|
| Roll damper        | [roll damper is a candidate loop]                    |
| Yaw damper         | [yaw damper is a candidate loop]                     |
| Sideslip to rudder | [sideslip to rudder is a candidate loop]             |
| Ay to rudder       | [lateral acceleration to rudder is a candidate loop] |

To continue, press F2

DISPLAY Candidate Architectures



## CANDIDATE FCS ARCHITECTURES

The candidate FCS architectures potentially useful for the control of the [Degrees of freedom for control] of this (aircraft type) have been identified and include:

To be examined:

- 1st [First architecture for consideration]
- 2nd [Second architecture for consideration]
- 3rd [Third architecture for consideration]

You may now begin FCS design.

To continue, press F2

TEXT RD&YD

Roll damper plus yaw damper

TEXT RD&B\_DR

Roll damper plus sideslip to rudder

TEXT RD&AY\_DR

Roll damper plus lateral acceleration to rudder

!

END

!"ARCH.PRL"

!

TITLE FCS ARCHITECTURE SELECTION EXPERT (ARCH) DISPLAY

This expert assists in the selection of one of the candidate architectures to be pursued for the current aircraft. This architecture is referred to as the "current architecture".

To continue, PRESS F3

!

!.....

!

Shared Facts Declarations

!

The Shared Facts Declaration is stored in the "include" file named "SHAREFCT.SHR" and combined with this knowledge base during compilation.

!

\$SHAREFCT.SHR

!

!.....

!

Data Type Declarations

!

!.....

!

Parameter Initialization Statements

!

!.....

!

Control Element Selectors

THRESHOLD - 100

CONFIDENCE OFF

GOALSELECT ON

UNKNOWN CONTINUE

\$EXHAUSTV.SHR

!.....

!

Multiattributed Objects Declarations

!

The "MULTI" Declaration of multiattributed objects is stored in the "include" file named "MULTI.SHR" and combined with this knowledge base during compilation.

\$MULTI.SHR

!.....

!

!

! Goal Outline

1. Current architecture has been selected

1.1. Selection of current architecture has been completed

!-----  
!  
! Rules  
!.....

! Rules for selecting the current architecture

! The current architecture is the one currently being designed and evaluated

RULE for making RD&YD current architecture  
IF Degrees of freedom for control ARE lateral directional axes  
AND First architecture for consideration IS RD&YD  
AND RD&YD assessment IS assessed and adequate  
THEN Current architecture has been selected  
AND Current architecture IS RD&B\_DR  
ELSE Current architecture has been selected  
AND Current architecture IS RD&YD

RULE for making RD&YD current architecture  
IF Degrees of freedom for control ARE lateral directional axes  
AND First architecture for consideration IS RD&YD  
AND RD&YD assessment IS assessed and inadequate  
THEN Current architecture has been selected  
AND Current architecture IS RD&YD

!.....  
!  
! Rules for setting the sequence of loop closures during design of the  
! current architecture

RULE for setting of loop closure order  
IF Current architecture IS RD&YD  
THEN First loop to design has been specified  
AND First loop to design IS yaw damper

!.....  
!  
! Rule for ending consultation

RULE for exiting ARCH expert  
IF First loop to design has been specified  
THEN Selection of current architecture has been completed  
AND DISPLAY Architecture summary  
AND FORGET Current loop has been specified  
AND FORGET Current loop connections are set for design  
AND FORGET Current system design model is setup

AND FORGET Current loop must be designed  
AND FORGET Current architecture has been designed  
AND CHAIN C:\FCSXPRT\DESIGN

!-----  
!  
! Information Display Text

DISPLAY Architecture summary

The current FCS architecture selected for consideration is:

[Current architecture]

The first loop recommended for design within this architecture is:

[First loop to design]

To continue, press F2

TEXT RD&YD

Roll damper plus yaw damper

TEXT RD&B\_DR

Roll damper plus sideslip to rudder

TEXT RD&AY\_DR

Roll damper plus lateral acceleration to rudder

TEXT B\_DR

Sideslip to rudder

TEXT AY\_DR

Lateral acceleration to rudder

!  
END

**DESIGN.PRL**

!"DESIGN.PRL"

!

TITLE FCS LOOP DESIGN EXPERT (DESIGN) DISPLAY

This expert assists in the design of individual loops.

To continue, PRESS F3

!

!.....

!

! Shared Facts Declarations

!

! The Shared Facts Declaration is stored in the "include" file named  
! "SHAREFCT.SHR" and combined with this knowledge base during compilation.

!

!\$SHAREFCT.SHR

!

!.....

!

! Data Type Declarations

!

!.....

!

! Parameter Initialization Statements

INIT yaw damper loop has been designed CF 0  
AND roll damper loop has been designed CF 0  
AND Sideslip to rudder loop has been designed CF 0  
AND Lateral acceleration to rudder loop has been designed CF 0

REINIT yaw damper loop has been designed CF 0  
AND roll damper loop has been designed CF 0  
AND Sideslip to rudder loop has been designed CF 0  
AND Lateral acceleration to rudder loop has been designed CF 0

!.....

!

! Control Element Selectors

THRESHOLD = 100  
CONFIDENCE OFF  
GOALSELECT ON  
UNKNOWN CONTINUE  
!\$EXHAUSTV.SHR

!.....

!

! Multiattributed Objects Declarations

!

! The "MULTI" Declaration of multiattributed objects is stored in the  
! "include" file named "MULTI.SHR" and combined with this knowledge base  
! during compilation.

\$MULTI.SHR

!.....

!

!

! Goal Outline

- 1. Current loop has been specified
  - 1.1. Current loop connections are set for design
    - 1.1.1. Current loop must be designed
      - 1.1.1.1. Current architecture has been designed

!

!-----

!

! Rules

!

!.....

!

! Rules for selecting the current loop

!

! The current loop is the one currently being designed and evaluated. Its  
! selection depends on what loops have previously been designed.

RULE for making yaw damper the current loop  
IF First loop to design IS yaw damper  
AND NOT Yaw damper loop has been designed  
THEN Current loop has been specified  
AND Current loop IS yaw damper

RULE for making yaw damper the current loop  
IF First loop to design IS yaw damper  
AND Yaw damper loop assessment IS assessed and inadequate  
THEN Current loop has been specified  
AND Current loop IS yaw damper

RULE for making roll damper the current loop  
IF Current architecture IS RD&YD  
AND Yaw damper loop assessment IS assessed and adequate  
THEN Current loop has been specified  
AND Current loop IS roll damper

RULE for making roll damper the current loop  
IF Current architecture IS RD&YD  
AND Yaw damper loop assessment IS assessed and adequate  
AND Roll damper loop assessment IS assessed and inadequate  
THEN Current loop has been specified  
AND Current loop IS roll damper

RULE for adequate RD&YD design  
IF Current architecture IS RD&YD  
AND Yaw damper loop assessment IS assessed and adequate  
AND Roll damper loop assessment IS assessed and adequate  
THEN Current loop has been specified  
AND Current loop connections are set for design  
AND Current loop must be designed

!.....  
!  
! Rules for setting loop connections

RULE for setting up RD&YD system design model  
IF Current architecture IS RD&YD  
AND Current loop IS yaw damper  
AND NOT Yaw damper loop has been designed  
THEN Current loop connections are set for design  
AND Yaw damper loop connection IS open  
AND Roll damper loop connection IS open  
AND Sideslip to rudder loop connection IS open  
AND Lateral acceleration to rudder loop connection IS open

RULE for setting up RD&YD system design model  
IF Current architecture IS RD&YD  
AND Current loop IS yaw damper  
AND Yaw damper loop assessment IS assessed and inadequate  
THEN Current loop connections are set for design  
AND Yaw damper loop connection IS open  
AND Roll damper loop connection IS open  
AND Sideslip to rudder loop connection IS open  
AND Lateral acceleration to rudder loop connection IS open

RULE for setting up RD&YD system design model  
IF Current architecture IS RD&YD  
AND Current loop IS roll damper  
AND Yaw damper loop assessment IS assessed and adequate  
THEN Current loop connections are set for design  
AND Yaw damper loop connection IS closed  
AND Roll damper loop connection IS open  
AND Sideslip to rudder loop connection IS open  
AND Lateral acceleration to rudder loop connection IS open

!.....  
!  
! Rules for initiating loop design

RULE for initiating yaw damper design  
IF Current loop IS yaw damper  
THEN current loop must be designed  
AND FORGET Perform complete yaw damper design  
AND FORGET Define yaw damper feedback equalization  
AND FORGET Define yaw damper gain



AND FORGET Yaw damper measurement query has been made  
 AND FORGET Yaw damper type has been determined  
 AND FORGET Yaw damper measurements are adequate  
 AND FORGET Aircraft operation is limited to low AOA  
 AND FORGET Aircraft operation is restricted to low AOA  
 AND FORGET Yaw damper measurement query has been made  
 AND FORGET Yaw damper measurements have been defined  
 AND FORGET Rate gyro tilt angle has been queried  
 AND FORGET Rate gyro tilt angle has been defined  
 AND FORGET Stability axis yaw damper should be designed  
 AND FORGET Measurement blending coefficients have been queried  
 AND FORGET Yaw damper feedback signal has been defined  
 AND FORGET Basic feedback transfer function has been obtained  
 AND FORGET rf|dr complex dipole is well separated  
 AND FORGET Complex dipole is suitable for a yaw damper  
 AND FORGET rf|dr pole zero configuration has been examined  
 AND FORGET Yaw damper washout must be reported  
 AND FORGET Yaw damper washout is defined  
 AND FORGET Yaw damper open loop transfer function has been created  
 AND FORGET Gain selection must be performed  
 AND FORGET yaw damper gain is defined  
 AND FORGET Yaw damper loop has been designed  
 AND FORGET a yaw damper is to be designed  
 AND FORGET previous design has been discarded  
 AND FORGET previous yaw damper measurement has been discarded  
 AND FORGET previous yaw damper washout has been discarded  
 AND FORGET previous yaw damper gain has been discarded  
 AND FORGET yaw damper is ready for assessment  
 AND FORGET Current system assessment model is setup  
 AND FORGET requirement comparison is complete  
 AND FORGET System model must be generated  
 AND FORGET FCS parameters are set  
 AND FORGET Return to calling expert  
 AND FORGET System model must be generated  
 AND FORGET System model has been generated  
 AND FORGET Specified system transfer function has been transmitted  
 AND FORGET System poles and zeros must be identified  
 AND FORGET Basic feedback transfer function has been obtained  
 AND CHAIN C:\FCSXPRT\YAWDMPR

RULE for initiating roll damper design

IF Current loop IS roll damper

THEN current loop must be designed

AND FORGET Define roll damper feedback equalization

AND FORGET Define lead time constant

AND FORGET Define lag time constant

AND FORGET Define roll damper gain

AND FORGET Roll damper lead inverse time constant has been defined

AND FORGET Roll damper lag inverse time constant has been defined

AND FORGET Define roll damper feedback equalization

AND FORGET Pure gain roll damper O.L. transfer function is generated

AND FORGET Pure gain roll damper has standard root locus topology

```

AND FORGET Roll damper requires lead equalization
AND FORGET Dutch roll locus goes to rigid body zero
AND FORGET Pure gain roll damper root locus has been examined
AND FORGET Roll damper requires lag equalization
AND FORGET Roll damper feedback equalization has been defined
AND FORGET Roll damper open loop transfer function is created
AND FORGET Gain selection must be performed
AND FORGET roll damper gain is defined
AND FORGET roll damper loop has been designed
AND FORGET roll damper is ready for assessment
AND FORGET Current system assessment model is setup
AND FORGET requirement comparison is complete
AND FORGET System model must be generated
AND FORGET FCS parameters are set
AND FORGET Return to calling expert
AND FORGET System model must be generated
AND FORGET System model has been generated
AND FORGET Specified system transfer function has been transmitted
AND FORGET System poles and zeros must be identified
AND FORGET Basic feedback transfer function has been obtained
AND CHAIN C:\FCSXPRT\ROLLDMPR

```

```

!.....
!
!   Rule for adequate design of current architecture

```

```

RULE for adequacy of current FCS design
IF Current architecture IS RD&YD
AND yaw damper loop assessment IS assessed and adequate
AND roll damper loop assessment IS assessed and adequate
THEN Current architecture has been designed
AND RD&YD assessment IS assessed and adequate
AND DISPLAY Current system
!   Save context
AND CHAIN C:\FCSXPRT\GENERATE

```

```

!
!.....
!
!   Information Display Text

```

```

DISPLAY Current system

```

The current loop structure recommended for assessment for control of the (Degrees of freedom for control) of a (aircraft type) is:

Current architecture:

[Current architecture]

Current loop:

[Current loop]

To continue, press F2

TEXT RD&YD

Roll damper plus yaw damper

TEXT RD&B\_DR

Roll damper plus sideslip to rudder

TEXT RD&AY\_DR

Roll damper plus lateral acceleration to rudder

TEXT B\_DR

Sideslip to rudder

TEXT AY\_DR

Lateral acceleration to rudder

!

END

**YAWDMPR.PRL**

```
! "YAWDMPR.PRL"
!  
!   SYSTEMS TECHNOLOGY, INC Hawthorne, CA
!  
TITLE  YAW DAMPER EXPERT   (YAWDMPR)           DISPLAY
```

This expert assists in the design of yaw damper loops.

To continue with yaw damper design, PRESS F3

```
!.....  
!  
!   Shared Facts Declarations  
!  
!   The Shared Facts Declaration is stored in the "include" file named  
!   "SHAREFCT.SHR" and combined with this knowledge base during compilation.  
!
```

```
$SHAREFCT.SHR
```

```
!.....  
!  
!   Data Type Declarations  
!  
NUMERIC dutch roll damping ratio
```

```
!.....  
!  
!   Parameter Initialization Statements
```

```
FORGET Perform complete yaw damper design  
AND Define yaw damper feedback equalization  
AND Define yaw damper gain  
AND Yaw damper measurement query has been made  
AND Yaw damper type has been determined  
AND Yaw damper measurements are adequate  
AND Aircraft operation is limited to low AOA  
AND Aircraft operation is restricted to low AOA  
AND Yaw damper measurement query has been made  
AND Rate gyro tilt angle has been queried  
AND Rate gyro tilt angle has been defined  
AND Stability axis yaw damper should be designed  
AND Measurement blending coefficients have been queried  
AND Yaw damper feedback signal has been defined  
AND Basic feedback transfer function has been obtained  
AND rf|dr complex dipole is well separated  
AND Complex dipole is suitable for a yaw damper  
AND rf|dr pole zero configuration has been examined  
AND Yaw damper washout must be reported  
AND Yaw damper washout is defined  
AND Yaw damper open loop transfer function has been created  
AND Gain selection must be performed
```

AND yaw damper gain is defined  
AND Yaw damper loop has been designed  
AND a yaw damper is to be designed  
! AND previous design has been discarded  
! AND previous yaw damper measurement has been discarded  
! AND previous yaw damper washout has been discarded  
! AND previous yaw damper gain has been discarded  
AND yaw damper is ready for assessment  
AND Current system assessment model is setup  
AND requirement comparison is complete

AND Yaw damper type

!.....

!  
! Control Element Selectors

THRESHOLD = 60  
CONFIDENCE OFF

CONFIDENCE Aircraft operation is limited to low AOA

GOALSELECT ON  
UNKNOWN CONTINUE  
\$EXHAUSTV.SHR

!.....

!  
! Multiattributed Objects Declarations  
!  
! The "MULTI" Declaration of multiattributed objects is stored in the  
! "include" file named "MULTI.SHR" and combined with this knowledge base  
! during compilation.

\$MULTI.SHR

!.....

!  
!  
! Goal Outline

- 1. Perform complete yaw damper design
  - 1.1 Yaw damper measurement query has been made
    - 1.1.1 Yaw damper measurements are adequate
      - 1.1.1.1 Yaw damper feedback signal has been defined
        - 1.1.1.1.1 Yaw damper washout is defined
          - 1.1.1.1.1.1 Yaw damper gain is defined
            - 1.1.1.1.1.1.1 Yaw damper is ready for assessment
              - 1.1.1.1.1.1.1.1 Yaw damper loop assessment IS WHAT

- 2. Define yaw damper feedback equalization
  - 2.1 Yaw damper washout is defined
    - 2.1.1 Yaw damper is ready for assessment
      - 2.1.1.1 Yaw damper loop assessment IS WHAT
- 3. Define yaw damper gain
  - 3.1 Yaw damper gain is defined
    - 3.1.1 Yaw damper is ready for assessment
      - 3.1.1.1 Yaw damper loop assessment IS WHAT

```

!
!-----
!
! Rules
!
!.....
!
! Rules for yaw damper measurement query

```

```

RULE for measurement selection by user
! Asks user to specify measurements to be used but insures that, if
! any are selected, yaw rate is included. Alternatively user can
! indicate any measurement as unknown.
IF ASK Yaw damper measurement
AND Yaw damper measurement IS Yaw rate
THEN Yaw damper measurement query has been made
! AND N5 := CONF(Yaw damper measurement IS Yaw rate)
! AND N6 := CONF(Yaw damper measurement IS Roll rate)
! AND DISPLAY measurement summary
ELSE NOT Yaw damper measurement query has been made
AND DISPLAY Yaw rate necessary
AND LOOP

```

```

RULE for unknown measurements
! Notes that measurement query has been made even if user indicates
! any measurement as unknown
IF CONF(Yaw damper measurement IS Yaw rate) = -2
OR CONF(Yaw damper measurement IS Roll rate) = -2
THEN Yaw damper measurement query has been made
AND N5 := CONF(Yaw damper measurement IS Yaw rate)
AND N6 := CONF(Yaw damper measurement IS Roll rate)
AND DISPLAY measurement summary

```

```

!.....
! Rules for yaw damper type

```

```

RULE for yaw damper type
IF Yaw damper measurement IS yaw rate
AND Yaw damper measurement IS roll rate
THEN Yaw damper type has been determined
AND Yaw damper type IS Yaw roll type

```

AND DISPLAY Yaw roll type display

RULE for yaw damper type  
IF Yaw damper measurement IS yaw rate  
AND NOT Yaw damper measurement IS roll rate  
THEN Yaw damper type has been determined  
AND Yaw damper type IS Yaw only type  
AND DISPLAY Yaw only type display

!.....  
!  
! Rules for measurement adequacy

RULE for measurement adequacy  
IF Yaw damper type IS Yaw roll type  
THEN Yaw damper measurements are adequate

RULE for measurement adequacy for low AOA  
IF Aircraft operation is limited to low AOA  
AND Yaw damper type IS Yaw only type  
OR Yaw damper type IS Yaw roll type  
THEN Yaw damper measurements are adequate

RULE for measurement inadequacy  
IF NOT Aircraft operation is limited to low AOA  
AND Yaw damper type IS Yaw only type  
THEN NOT Yaw damper measurements are adequate  
AND DISPLAY Roll measurement required  
AND CYCLE

RULE for low AOA operation query  
IF ASK Aircraft operation is restricted to low AOA  
AND Aircraft operation is restricted to low AOA  
THEN Aircraft operation is limited to low AOA  
ELSE NOT Aircraft operation is limited to low AOA

RULE for low AOA operation  
IF Aircraft classification IS Class IV  
THEN NOT Aircraft operation is limited to low AOA CF 95  
AND DISPLAY Class IV AOA range

!.....  
!  
! Rules for using tilted rate gyros

RULE for gyro tilt query  
IF Yaw damper type IS Yaw only type  
AND DISPLAY Gyro tilt  
AND ASK Rate gyro tilt angle  
THEN Rate gyro tilt angle has been queried



RULE for gyro tilt angle  
IF Rate gyro tilt angle has been queried  
AND CONF(Rate gyro tilt angle) > 0  
THEN Rate gyro tilt angle has been defined  
AND N7 := Rate gyro tilt angle

RULE for unknown gyro tilt angle  
IF Yaw damper type IS Yaw only type  
AND CONF(Rate gyro tilt angle) = -2  
THEN Stability axis yaw damper should be designed  
AND Rate gyro tilt angle := alpha0  
AND Rate gyro tilt angle has been defined  
AND N7 := Rate gyro tilt angle

!.....  
!  
! Rules for blending yaw and roll rates in Yaw roll type yaw dampers

RULE for measurement blending query  
IF Yaw damper type IS Yaw roll type  
AND DISPLAY Blending coefficients  
AND ASK Yaw rate blending coefficient  
AND ASK Roll rate blending coefficient  
THEN Measurement blending coefficients have been queried

RULE for measurement blending coefficients  
IF Measurement blending coefficients have been queried  
AND CONF(Yaw rate blending coefficient) > 0  
AND CONF(Roll rate blending coefficient) > 0  
THEN Measurement blending coefficients have been defined  
AND N4 := Yaw rate blending coefficient  
AND N3 := Roll rate blending coefficient  
AND S1 := "Kpblend = "  
AND S2 := "Krbblend = "

RULE for measurement blending coefficients  
IF Yaw damper type IS Yaw roll type  
THEN Stability axis yaw damper should be designed  
AND Yaw rate blending coefficient := COS(alpha0/57.3)  
AND Roll rate blending coefficient := -SIN(alpha0/57.3)  
AND Measurement blending coefficients have been defined  
AND N4 := Yaw rate blending coefficient  
AND N3 := Roll rate blending coefficient  
AND S1 := "-Sin(AOA) = "  
AND S2 := "Cos(AOA) = "

!.....  
!  
! Rules for definition of yaw damper feedback signal

RULE for yaw damper signal  
IF Yaw damper measurements are adequate

AND Yaw damper type IS Yaw only type  
AND Rate gyro tilt angle has been defined  
THEN Yaw damper feedback signal has been defined  
AND DISPLAY Yaw damper summary #1

RULE for yaw damper signal  
IF Yaw damper measurements are adequate  
AND Yaw damper type IS Yaw roll type  
AND Measurement blending coefficients have been defined  
THEN Yaw damper feedback signal has been defined  
AND DISPLAY Yaw damper summary #2

!.....  
!  
! Rules for generating the basic feedback transfer function

RULE for feedback transfer function  
IF Yaw damper type IS Yaw only type  
AND Yaw damper feedback signal has been defined  
THEN System model must be generated  
AND Expert requesting SYSMOD IS YAWDMPR expert  
AND FORGET FCS parameters are set  
AND FORGET System model has been generated  
AND FORGET Return to calling expert  
AND Calling expert IS YAWDMPR expert  
AND CHAIN C:\FCSXPRT\SYSMOD

RULE for feedback transfer function  
IF Yaw damper type IS Yaw roll type  
AND Yaw damper feedback signal has been defined  
THEN System model must be generated  
AND Expert requesting SYSMOD IS YAWDMPR expert  
AND FORGET FCS parameters are set  
AND FORGET System model has been generated  
AND FORGET Return to calling expert  
AND Calling expert IS YAWDMPR expert  
AND CHAIN C:\FCSXPRT\SYSMOD

RULE for bringing open loop rf|δr into knowledge base  
IF System model must be generated  
AND System model has been generated  
THEN Specified system transfer function has been transmitted  
AND FORGET Return to calling expert  
AND FORGET Specified system transfer function has been transmitted  
AND Transfer function \$\$g filename := "G26032"  
AND CHAIN C:\FCSXPRT\TFEXT

RULE for identifying the poles and zeros  
IF Specified system transfer function has been transmitted  
THEN System poles and zeros must be identified  
AND Basic feedback transfer function has been obtained  
AND FORGET System poles are identified

AND FORGET Return to calling expert  
AND CHAIN C:\FCSXPRT\ROOTID  
AND System poles are identified

!.....  
!  
! Rules for determining the suitability of the basic feedback transfer  
! function with respect to positioning of complex dipole.

RULE for basic feedback signal suitability  
IF Basic feedback transfer function has been obtained  
AND ASK rf|dr complex dipole is well separated  
AND rf|dr complex dipole is well separated  
THEN Complex dipole is suitable for a yaw damper  
ELSE DISPLAY Unsuitable complex dipole  
AND CYCLE

RULE for examining rf|dr pole zero configuration  
IF CONF(rf|dr complex dipole is well separated) = -2  
! AND DISPLAY  
! Routine to display root locus of rf|dr (\$\$g26032)  
!  
THEN rf|dr pole zero configuration has been examined  
AND ASK rf|dr complex dipole is well separated

RULE for suitable dipole  
IF rf|dr pole zero configuration has been examined  
AND rf|dr complex dipole is well separated  
THEN Complex dipole is suitable for a yaw damper

RULE for suitable dipole  
IF rf|dr pole zero configuration has been examined  
AND NOT rf|dr complex dipole is well separated  
THEN NOT Complex dipole is suitable for a yaw damper  
AND DISPLAY Unsuitable complex dipole  
AND CYCLE

RULE for suitable yaw damper feedback signal  
IF Wrs/Wd < .6  
AND CONF(rf|dr complex dipole is well separated) = -2  
THEN rf|dr complex dipole is well separated CF 80  
AND Complex dipole is suitable for a yaw damper

!.....  
!  
! Rules for initial setting of yaw damper washout

RULE for requesting washout time constant  
IF Complex dipole is suitable for a yaw damper  
AND CONF(dutch roll damping ratio assessment IS adequate) < 0  
AND CONF(dutch roll damping ratio assessment IS too low) < 0  
AND ASK Yaw damper washout inverse time constant

AND Yaw damper washout inverse time constant > 0.0  
THEN Yaw damper washout must be reported

RULE for setting initial washout time constant  
IF Complex dipole is suitable for a yaw damper  
AND CONF(Yaw damper washout inverse time constant) = -2  
AND CONF(dutch roll damping ratio assessment IS adequate) < 0  
AND CONF(dutch roll damping ratio assessment IS too low) < 0  
THEN Yaw damper washout must be reported  
AND Yaw damper washout inverse time constant := Wd/2  
AND DISPLAY Recommended washout

!.....

!

! Rules for adjusting previous washout time constant

RULE for examining yaw damper root locus  
IF CONF(dutch roll damping ratio assessment IS too low) > 0  
AND DISPLAY Yaw damper root locus  
! AND CHAIN C:\STI\CC.EXE  
AND ASK Yaw damper washout inverse time constant  
AND Yaw damper washout inverse time constant > 0.0  
THEN Yaw damper washout must be reported

RULE for adjusting washout time constant  
IF Complex dipole is suitable for a yaw damper  
AND CONF(dutch roll damping ratio assessment IS too low) > 0  
AND Yaw damper washout inverse time constant > Wd/3  
THEN Yaw damper washout must be reported CF 75  
AND Yaw damper washout inverse time constant := -(Wd/2) + :  
Yaw damper washout inverse time constant

RULE for adjusting washout time constant  
IF Complex dipole is suitable for a yaw damper  
AND CONF(dutch roll damping ratio assessment IS too low) > 0  
AND Yaw damper washout inverse time constant <= Wd/3  
THEN Yaw damper washout must be reported CF 75  
AND Yaw damper washout inverse time constant := (Wd/2) + :  
Yaw damper washout inverse time constant

RULE yaw damper summary display  
IF Yaw damper type IS Yaw only type  
AND Yaw damper washout must be reported  
THEN Yaw damper washout is defined  
AND Yaw damper washout time constant := :  
1/(Yaw damper washout inverse time constant)  
AND N2 := Yaw damper washout inverse time constant  
AND DISPLAY yaw damper summary #1

RULE yaw damper summary display  
IF Yaw damper type IS Yaw roll type  
AND Yaw damper washout must be reported

```
THEN Yaw damper washout is defined
AND Yaw damper washout time constant :- :
1/(Yaw damper washout inverse time constant)
AND N2 :- Yaw damper washout inverse time constant
AND DISPLAY yaw damper summary #2
```

```
!.....
!  
! Rules for setting yaw damper gain
```

```
RULE for generating open loop transfer function
IF Yaw damper washout is defined
THEN System model must be generated
AND Yaw damper open loop transfer function has been generated ! *****
AND Expert requesting SYSMOD IS YAWDMPR expert
AND FORGET FCS parameters are set
AND FORGET System model has been generated
AND FORGET Return to calling expert
AND Calling expert IS YAWDMPR expert
AND CHAIN C:\FCSXPRT\SYSMOD
```

```
RULE for bringing open loop transfer function into knowledge base
IF System model must be generated
AND System model has been generated
AND Yaw damper open loop transfer function has been generated ! *****
THEN Yaw damper open loop transfer function has been transmitted ! *****
AND FORGET Return to calling expert
AND FORGET Specified system transfer function has been transmitted
AND Transfer function $$g filename :- "G26052"
AND CHAIN C:\FCSXPRT\TFEXT
```

```
RULE for identifying the poles and zeros
IF Yaw damper open loop transfer function has been transmitted ! *****
THEN System poles and zeros must be identified
AND Yaw damper open loop transfer function has been created
AND FORGET System poles are identified
AND FORGET Return to calling expert
AND CHAIN C:\FCSXPRT\ROOTID
AND System poles are identified
```

```
RULE For obtaining yaw damper gain
IF Yaw damper open loop transfer function has been created
AND DISPLAY Gain selection
THEN Gain selection must be performed
AND FORGET Specify loop gain directly
AND FORGET Loop gain has been specified directly
AND FORGET Examine Root Locus to set the gain
AND FORGET Loop gain has been specified from root locus
AND FORGET Examine Bode siggy to set the gain
AND FORGET Loop gain has been specified from Bode Siggy
AND FORGET Loop gain has been specified
AND FORGET Loop gain is defined
```

AND FORGET Terminate gain selection  
AND FORGET Return to calling module  
AND CHAIN C:\FCSXPRT\GAINSEL  
AND Yaw damper gain is defined

!-----

!  
! Rules for completion of yaw damper design

RULE for completion of a yaw damper design  
IF Yaw damper type IS Yaw only type  
AND Yaw damper feedback signal has been defined  
AND Yaw damper washout is defined  
AND Yaw damper gain is defined  
THEN Yaw damper loop has been designed  
AND yaw damper gain := loop gain  
AND N1 := Yaw damper gain  
AND DISPLAY Yaw damper summary #1  
AND FORGET a yaw damper is to be designed  
! AND FORGET previous design has been discarded  
! AND FORGET previous yaw damper measurement has been discarded  
! AND FORGET previous yaw damper washout has been discarded  
! AND FORGET previous yaw damper gain has been discarded

RULE for completion of a yaw damper design  
IF Yaw damper type IS Yaw roll type  
AND Yaw damper feedback signal has been defined  
AND Yaw damper washout is defined  
AND Yaw damper gain is defined  
THEN Yaw damper loop has been designed  
AND yaw damper gain := loop gain  
AND N1 := Yaw damper gain  
AND DISPLAY Yaw damper summary #2  
AND FORGET a yaw damper is to be designed  
! AND FORGET previous design has been discarded  
! AND FORGET previous yaw damper measurement has been discarded  
! AND FORGET previous yaw damper washout has been discarded  
! AND FORGET previous yaw damper gain has been discarded

!.....

!  
! Rules for assessing yaw damper design

RULE for setting up current system assessment model  
IF Yaw damper loop has been designed  
AND DISPLAY design assessment  
THEN System model must be generated  
AND Yaw damper assessment dynamics have been generated !\*\*\*\*\*  
AND Yaw damper loop connection IS closed  
AND Expert requesting SYSMOD IS YAWDMPR expert  
AND FORGET FCS parameters are set  
AND FORGET System model has been generated

AND FORGET Return to calling expert  
AND Calling expert IS YAWDMPR expert  
AND CHAIN C:\FCSXPRT\SYSMOD

RULE for bringing closed loop  $\delta r_f$  |  $\delta r$  into knowledge base  
IF System model must be generated  
AND System model has been generated  
AND Yaw damper assessment dynamics have been generated !\*\*\*\*\*  
THEN Specified system transfer function has been transmitted  
AND Yaw damper assessment dynamics have been transmitted !\*\*\*\*\*  
AND FORGET Return to calling expert  
AND FORGET Specified system transfer function has been transmitted  
AND Transfer function \$\$g filename := "G26052" ! \$\$gname ???????  
AND CHAIN C:\FCSXPRT\TFEXT

RULE for identifying the closed loop poles and zeros  
IF Specified system transfer function has been transmitted  
AND Yaw damper assessment dynamics have been transmitted !\*\*\*\*\*  
THEN System poles and zeros must be identified  
AND Current system assessment model is setup  
AND System poles and zeros have been identified  
AND Yaw damper dynamics are ready for assessment !\*\*\*\*\*  
AND FORGET System poles are identified  
AND FORGET Return to calling expert  
AND CHAIN C:\FCSXPRT\ROOTID  
AND DISPLAY dynamic characteristics

RULE for assessing the closed loop dynamics  
IF System poles and zeros have been identified  
AND Yaw damper dynamics are ready for assessment !\*\*\*\*\*  
THEN Yaw damper is ready for assessment  
AND FORGET dutch roll damping ratio has been assessed  
AND FORGET dutch roll mode dynamics are adequate  
AND FORGET dutch roll mode has been compared with the requirements  
AND FORGET modal dynamics are adequate  
AND FORGET system has been compared with the requirements  
AND FORGET requirement comparison is complete  
! AND FORGET dutch roll damping ratio assessment  
AND CHAIN C:\FCSXPRT\ASSESS  
AND DISPLAY dynamics assessment  
! AND System requirement check has been made !TEMPORARY

!.....  
!  
! Rules for deciding what to do after yaw damper assessment  
! is completed

RULE for treating an inadequate yaw damper design  
IF requirement comparison is complete  
AND dutch roll damping ratio assessment IS too low  
THEN Yaw damper loop assessment IS assessed and inadequate

AND DISPLAY Inadequate yaw damper  
AND CYCLE

RULE for treating an adequate yaw damper design  
IF requirement comparison is complete  
AND dutch roll damping ratio assessment IS adequate  
THEN Yaw damper loop assessment IS assessed and adequate  
AND DISPLAY Adequate yaw damper  
AND FORGET Current loop has been specified  
AND FORGET Current loop connections are set for design  
AND FORGET Current system design model is setup  
AND FORGET Current loop must be designed  
AND FORGET Current architecture has been designed  
AND CHAIN C:\FCSXPRT\DESIGN

!-----  
!  
! Information Display Text

DISPLAY Yaw rate necessary

To construct a practical yaw damper, yaw rate must be one of the measurements used in the design.

To continue, press F2

DISPLAY Measurement summary

Summary of measurements selected for use in the yaw damper:

| Measurement | Confidence factor for selection |
|-------------|---------------------------------|
| Yaw rate    | [N5]                            |
| Roll rate   | [N6]                            |

To continue, press F2

DISPLAY Yaw roll type display

Current yaw damper design uses both yaw and roll rate measurements



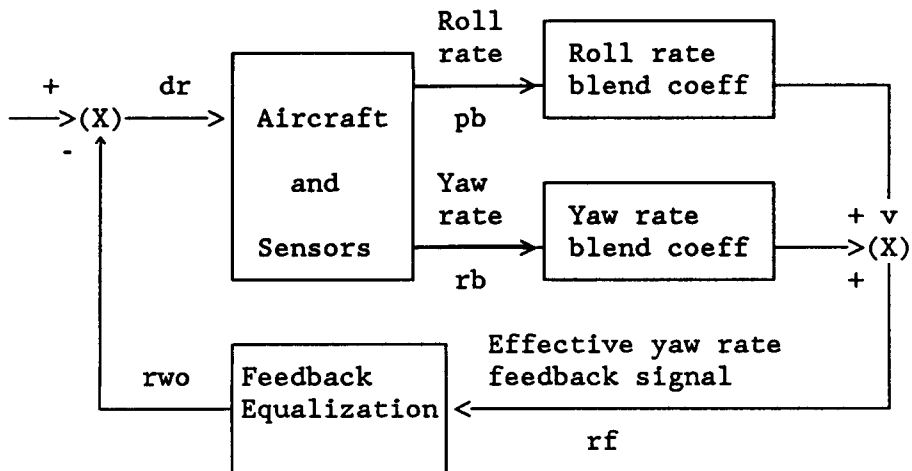

To continue, press F2

DISPLAY Yaw only type display

Current yaw damper design uses only a yaw rate measurement

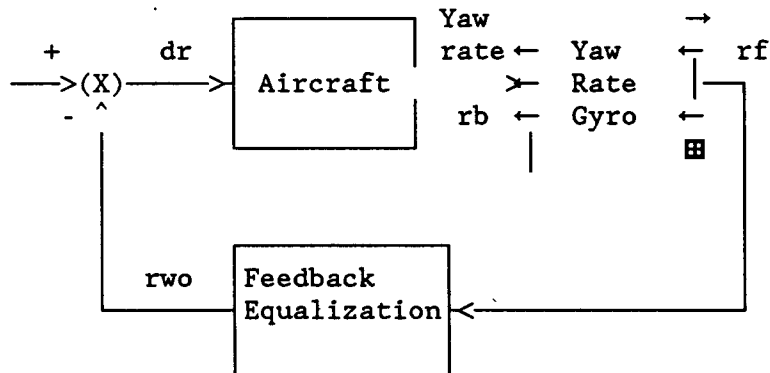

To continue, press F2

DISPLAY Roll measurement required

Use of roll rate in addition to yaw rate is indicated.

Since it appears that the [aircraft designation] operates over a wide range of angle of attack, significant movement of the complex yaw rate zero can be expected. Thus use of only a yaw rate measurement (regardless of gyro tilt) will probably not be adequate and a roll rate measurement should also be used.

To restart the yaw damper design, press F2

DISPLAY Class IV AOA range

Class IV aircraft such as this [aircraft type] are highly maneuverable and generally operate over a wide angle of attack range.

To continue, press F2

DISPLAY Yaw damper summary #1

Current yaw damper

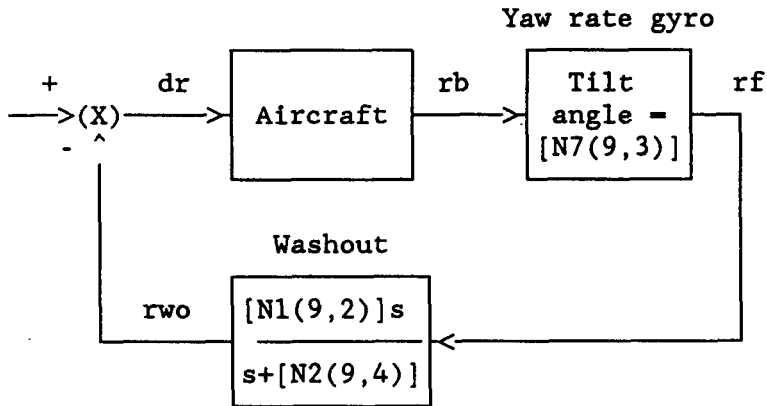

To continue, press F2

DISPLAY Yaw damper summary #2

Current yaw damper

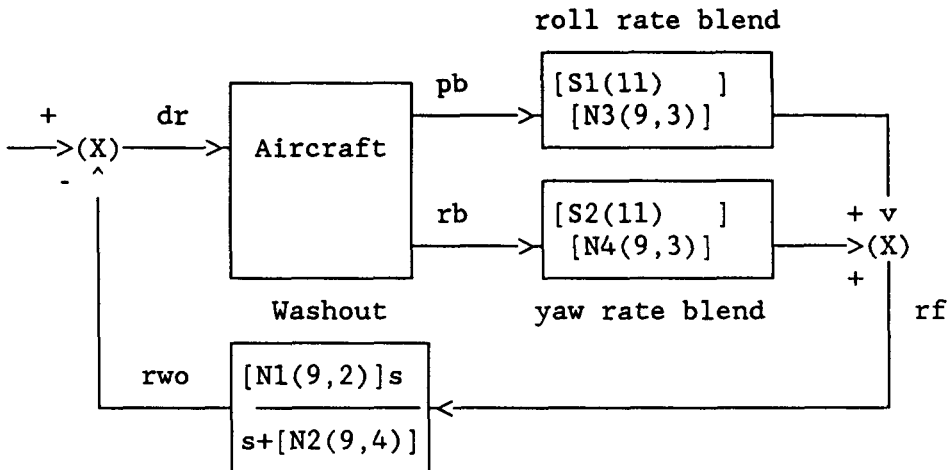

To continue, press F2

DISPLAY Gyro tilt

RATE GYRO INCLINATION

You must now specify the orientation of the yaw damper rate gyro in the aircraft body (fuselage reference line) axis system by specifying the inclination or "tilt" angles in degrees. When prompted:

Enter a numerical value and press ENTER key OR

If the tilt angle is unknown, press F2

To continue, press F2

Since only yaw rate is to be used in the yaw damper design, the inclination of the gyro significantly affects the suitability of the feedback signal. The gyro tilt angle is the angle between the sensitive axis of the gyro and the aircraft body Z axis, positive when the gyro axis is aft of the aircraft Z axis.

DISPLAY Blending coefficients

YAW and ROLL RATE BLENDING COEFFICIENTS

Enter yaw and roll rate blending coefficients when prompted:

Enter a numerical value and press ENTER key OR

If the coefficient is unknown, press F2

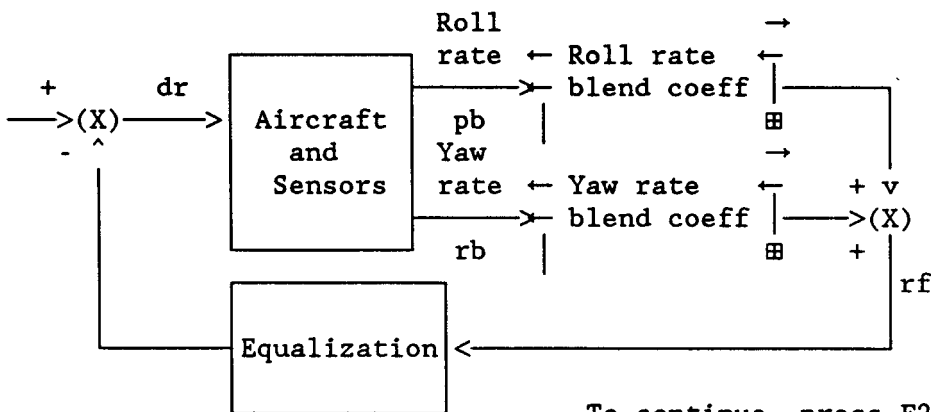

To continue, press F2

DISPLAY Unsuitable complex dipole

The complex  $W_r|W_d$  dipole in the effective yaw rate to rudder transfer function ( $rf|dr$ ) must be well separated to create a good yaw damper. Since this does not appear to be the case, adjustments in the feedback signal will have to be made.

To revise the design, press F2

DISPLAY Yaw damper root locus

The dutch roll damping ratio for the current yaw damper design is [dutch roll damping ratio].

To view the yaw damper root locus, press F2

DISPLAY Recommended washout

Yaw Damper Washout

The yaw damper washout inverse time constant should generally be placed about an octave below the dutch roll mode which is  $[Wd(9,2)]$  rad/sec.

Thus an initial washout inverse time constant of [yaw damper washout inverse time constant] rad/sec has been selected.

To continue, press F2

DISPLAY Gain selection

The open loop transfer function for the yaw damper is now defined and the final step is selection of the loop gain.

To select the loop gain, press F2

DISPLAY dynamic characteristics

The dynamics characteristics have been obtained for the system

To continue, Press F2

DISPLAY dynamics assessment

The assessment of the system dynamics indicates the following problems:

To continue, Press F2

DISPLAY design assessment

The yaw damper design is now complete.

To begin assessment of the design, Press F2

DISPLAY Inadequate yaw damper

Assessment of the current yaw damper design indicates that the dutch roll damping ratio is [dutch roll damping ratio assessment]

Thus the yaw damper loop is [Yaw damper loop assessment]

The yaw damper design should be revised. As a minimum the gain should be increased, but modification of the washout may also be necessary.

To begin design revision, press F2

DISPLAY Adequate yaw damper

Assessment of the current yaw damper design indicates that the dutch roll damping ratio is [dutch roll damping ratio assessment]

Thus the yaw damper loop is [Yaw damper loop assessment]

To continue the FCS design, Press F2

EXPAND  $r_f|d_r$  complex dipole is well separated

The pole and zero in the complex dutch roll dipole of the effective yaw rate to rudder transfer function ( $r_f|d_r$ ) must be well separated to create a good yaw damper.

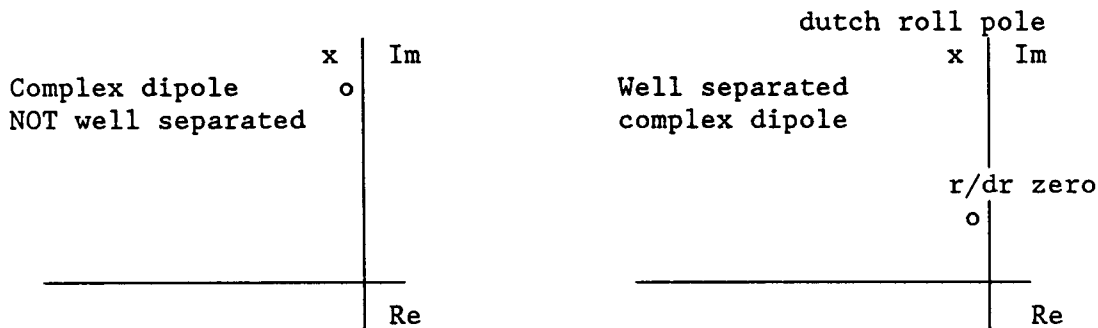

To continue press F8

EXPAND Aircraft operation is restricted to low AOA

Operation at low angles of attack (AOA) implies that the aircraft's aerodynamic characteristics are quite linear with angle of attack and that differences in stability axis and body axis quantities tend to be small. Restriction to low angles of attack means that the operational range of angle attack is small.

To continue press F8

!  
END

**ROLDMPR.PRL**

```
! "ROLLDMPR.PRL"
!  
!   SYSTEMS TECHNOLOGY, INC Hawthorne, CA
!  
! TITLE  ROLL DAMPER EXPERT  {ROLLDMPR}          DISPLAY
```

This expert assists in the design of roll damper loops.

To continue with roll damper design, PRESS F3

```
!.....
!  
!   Shared Facts Declarations
!  
!   The Shared Facts Declaration is stored in the "include" file named
!   "SHAREFCT.SHR" and combined with this knowledge base during compilation.
```

\$SHAREFCT.SHR

```
!.....
!  
!   Data Type Declarations
!  
!.....
!  
!   Parameter Initialization Statements
!  
!.....
!  
!   Control Element Selectors
```

```
THRESHOLD - 60
CONFIDENCE OFF
GOALSELECT ON
UNKNOWN CONTINUE
$EXHAUSTV.SHR
```

```
!.....
!  
!   Multiattributed Objects Declarations
!  
!   The "MULTI" Declaration of multiattributed objects is stored in the
!   "include" file named "MULTI.SHR" and combined with this knowledge base
!   during compilation.
```

\$MULTI.SHR

```
!.....
!  
!   Goal Outline
```



1. Define roll damper feedback equalization
  - 1.1 Define lead time constant
    - 1.1.1 Pure gain roll damper OLTF has been generated ! \*\*\*\*\*
      - 1.1.1.1 roll damper feedback equalization has been defined
        - 1.1.1.1.1 roll damper is ready for assessment
          - 1.1.1.1.1.1 roll damper loop assessment IS WHAT
  - 1.2 Define lag time constant
    - 1.2.1 Pure gain roll damper OLTF has been generated ! \*\*\*\*\*
      - 1.2.1.1 roll damper feedback equalization has been defined
        - 1.2.1.1.1 roll damper is ready for assessment
          - 1.2.1.1.1.1 roll damper loop assessment IS WHAT
2. Define roll damper gain
  - 2.1 roll damper gain is defined
    - 2.1.1 roll damper is ready for assessment
      - 2.1.1.1 roll damper loop assessment IS WHAT

```

!
!-----
!
! Rules
!
!.....
!
! Rules for obtaining pure gain roll damper open loop model

```

```

RULE for generating unequalized open loop pb|δa transfer function
IF Define lead time constant
OR Define lag time constant
THEN System model must be generated
AND Expert requesting SYSMOD IS ROLLDMPR expert
AND FORGET FCS parameters are set
AND FORGET System model has been generated
AND FORGET Return to calling expert
AND Calling expert IS ROLLDMPR expert
AND CHAIN C:\FCSXPRT\SYSMOD

```

```

RULE for bringing unequalized open loop pb|δa into knowledge base
IF System model must be generated
AND System model has been generated
THEN Specified system transfer function has been transmitted
AND FORGET Return to calling expert
AND FORGET Specified system transfer function has been transmitted
AND Transfer function $$g filename :- "G26011"
AND CHAIN C:\FCSXPRT\TFEXT

```

```

RULE for identifying the poles and zeros
IF Specified system transfer function has been transmitted
THEN System poles and zeros must be identified
AND Basic feedback transfer function has been obtained

```

```
AND Pure gain roll damper OLF has been generated
AND FORGET System poles are identified
AND FORGET Return to calling expert
AND CHAIN C:\FCSXPRT\ROOTID
AND System poles are identified
```

```
!.....
```

```
!
```

```
! Rules for setting equalization from user specification
```

```
RULE for lead inverse time constant query
IF ASK Roll damper lead inverse time constant
AND Roll damper lead inverse time constant > 0
AND CONF(Roll damper lead inverse time constant) > 0
THEN Roll damper lead inverse time constant has been defined
AND N21 := Roll damper lead inverse time constant
! AND DISPLAY
! ELSE DISPLAY Positive time constant
! AND LOOP
```

```
RULE for lag time constant query
IF ASK Roll damper lag inverse time constant
AND Roll damper lag inverse time constant > 0
AND CONF(Roll damper lag inverse time constant) > 0
THEN Roll damper lag inverse time constant has been defined
AND N22 := Roll damper lag inverse time constant
! AND DISPLAY
! ELSE DISPLAY Positive time constant
! AND LOOP
```

```
!.....
```

```
!
```

```
! Rules for equalization form required
```

```
RULE for generating pure gain open loop transfer function
IF Define roll damper feedback equalization
! AND ACTIVATE C:\CC.EXE
THEN Pure gain roll damper O.L. transfer function is generated
```

```
RULE for lead equalization
IF Pure gain roll damper has standard root locus topology
THEN NOT Roll damper requires lead equalization
ELSE Roll damper requires lead equalization
```

```
RULE for standard pure gain root locus
IF CONF(Pure gain roll damper has standard root locus topology) = -2
AND Pure gain roll damper O.L. transfer function is generated
AND DISPLAY Standard root locus
! AND ACTIVATE C:\STI\CC.EXE
AND ASK Dutch roll locus goes to rigid body zero
THEN Pure gain roll damper root locus has been examined
```

RULE for standard root locus topology  
IF Pure gain roll damper root locus has been examined  
AND Dutch roll locus goes to rigid body zero  
THEN Pure gain roll damper has standard root locus topology

RULE for lag equalization  
IF Roll damper requires lead equalization  
THEN Roll damper requires lag equalization

RULE for lead placement  
IF Roll damper requires lead equalization  
AND CONF(Roll damper lead inverse time constant) = -2  
AND Pure gain roll damper O.L. transfer function is generated  
AND DISPLAY Lead placement  
! AND ACTIVATE C:\STI\CC.EXE  
AND ASK Roll damper lead inverse time constant  
AND Roll damper lead inverse time constant > 0  
THEN Roll damper lead inverse time constant has been defined  
AND N21 := Roll damper lead inverse time constant  
! AND DISPLAY

RULE for lag placement  
IF Roll damper requires lag equalization  
AND CONF(Roll damper lag inverse time constant) = -2  
AND Roll damper lead inverse time constant has been defined  
THEN Roll damper lag inverse time constant has been defined  
AND Roll damper lag inverse time constant := 5\*(Roll damper lead :  
inverse time constant)  
AND N22 := Roll damper lag inverse time constant  
AND DISPLAY Recommended lag

!.....  
!  
! Rule for definition of roll damper feedback equalization

RULE for equalization definition  
IF Roll damper lead inverse time constant has been defined  
AND Roll damper lag inverse time constant has been defined  
THEN Roll damper feedback equalization has been defined  
AND DISPLAY roll damper summary

RULE for no lead required  
IF NOT Roll damper requires lead equalization  
THEN Roll damper feedback equalization has been defined  
AND N21 := 99999999999999999999.  
AND DISPLAY roll damper summary

!.....  
!  
! Rules for setting roll damper gain

```

RULE for generating open loop transfer function
IF Roll damper feedback equalization has been defined
THEN System model must be generated
AND Roll damper open loop transfer function has been generated ! *****
AND Expert requesting SYSMOD IS ROLLDMPR expert
AND FORGET FCS parameters are set
AND FORGET System model has been generated
AND FORGET Return to calling expert
AND Calling expert IS ROLLDMPR expert
AND CHAIN C:\FCSXPRT\SYSMOD

```

```

RULE for bringing open loop equalized pb|δa into knowledge base
IF System model must be generated
AND System model has been generated
AND Roll damper open loop transfer function has been generated ! *****
THEN Roll damper open loop transfer function has been transmitted ! *****
AND FORGET Return to calling expert
AND FORGET Specified system transfer function has been transmitted
AND Transfer function $$g filename :- "G26041"
AND CHAIN C:\FCSXPRT\TFEXT

```

```

RULE for identifying the poles and zeros
IF Roll damper open loop transfer function has been transmitted ! *****
THEN System poles and zeros must be identified
AND Roll damper open loop transfer function has been created
AND roll damper open loop transfer function is created
AND FORGET System poles are identified
AND FORGET Return to calling expert .
AND CHAIN C:\FCSXPRT\ROOTID
AND System poles are identified

```

```

RULE For obtaining roll damper gain
IF roll damper open loop transfer function is created
THEN Gain selection must be performed
AND FORGET Specify loop gain directly
AND FORGET Loop gain has been specified directly
AND FORGET Examine Root Locus to set the gain
AND FORGET Loop gain has been specified from root locus
AND FORGET Examine Bode siggy to set the gain
AND FORGET Loop gain has been specified from Bode Siggy
AND FORGET Loop gain has been specified
AND FORGET Loop gain is defined
AND FORGET Terminate gain selection
AND FORGET Return to calling module
AND CHAIN C:\FCSXPRT\GAINSEL
AND roll damper gain is defined

```

```

!-----
!
! Rules for completion of roll damper design

```

```
RULE for completion of a roll damper design
IF Roll damper feedback equalization has been defined
AND roll damper gain is defined
THEN roll damper loop has been designed
AND roll damper gain := loop gain
AND N23 := roll damper gain
AND DISPLAY roll damper summary
```

```
!.....
```

```
!
```

```
! Rules for assessing roll damper design
```

```
RULE for setting up current system assessment model
IF Roll damper loop has been designed
AND DISPLAY design assessment
THEN System model must be generated
AND Roll damper assessment dynamics have been generated !*****
AND Roll damper loop connection IS closed
AND Expert requesting SYSMOD IS ROLLDMPR expert
AND FORGET FCS parameters are set
AND FORGET System model has been generated
AND FORGET Return to calling expert
AND Calling expert IS ROLLDMPR expert
AND CHAIN C:\FCSXPRT\SYSMOD
```

```
RULE for bringing open loop  $\delta a_f | \delta a$  into knowledge base
IF System model must be generated
AND System model has been generated
AND Roll damper assessment dynamics have been generated !*****
THEN Specified system transfer function has been transmitted
AND Roll damper assessment dynamics have been transmitted !*****
AND FORGET Return to calling expert
AND FORGET Specified system transfer function has been transmitted
AND Transfer function $$g filename := "G26041"
AND CHAIN C:\FCSXPRT\TFEXT
```

```
RULE for identifying the poles and zeros
IF Specified system transfer function has been transmitted
AND Roll damper assessment dynamics have been transmitted !*****
THEN System poles and zeros must be identified
AND Current system assessment model is setup
AND System poles and zeros have been identified
AND Roll damper dynamics are ready for assessment !*****
AND FORGET System poles are identified
AND FORGET Return to calling expert
AND CHAIN C:\FCSXPRT\ROOTID
AND DISPLAY dynamic characteristics
```

```
RULE for assessing the closed loop dynamics
IF System poles and zeros have been identified
AND Roll damper dynamics are ready for assessment !*****
THEN Roll damper is ready for assessment
```

AND FORGET roll mode time constant has been assessed  
AND FORGET roll subsidence mode dynamics are adequate  
AND FORGET roll subsidence mode has been assessed  
AND FORGET modal dynamics are adequate  
AND FORGET system has been compared with the requirements  
AND FORGET requirement comparison is complete  
! AND FORGET roll subsidence damping ratio assessment  
AND CHAIN C:\FCSXPRT\ASSESS  
AND DISPLAY dynamics assessment  
! AND System requirement check has been made !TEMPORARY

!.....  
!  
! Rules for deciding what to do after roll damper assessment is  
! completed

RULE for treating an inadequate roll damper design  
IF requirement comparison is complete  
AND roll subsidence mode time constant assessment IS too high  
THEN roll damper loop assessment IS assessed and inadequate  
AND DISPLAY Assessment Summary  
AND CYCLE

RULE for treating an adequate roll damper design  
IF requirement comparison is complete  
AND roll subsidence mode time constant assessment IS adequate  
THEN roll damper loop assessment IS assessed and adequate  
AND DISPLAY Assessment Summary  
AND FORGET Current loop has been specified  
AND FORGET Current loop connections are set for design  
AND FORGET Current system design model is setup  
AND FORGET Current loop must be designed  
AND FORGET Current architecture has been designed  
AND CHAIN C:\FCSXPRT\DESIGN

!-----  
!  
! Information Display Text  
  
! DISPLAY Positive time constant  
  
! The roll damper lead and lag time constants must be greater than zero and  
! specified in radians per second.

! To continue, press F2

DISPLAY Lead placement

If the pure gain roll damper root locus topology is nonstandard, i.e., the dutch roll locus does not go into the low frequency "Wphi" complex zero, then lead equalization is probably necessary. The lead should be placed below the

lowest high frequency (actuator, etc.) mode but well above the rigid body (dutch roll, roll subsidence and spiral) modes

The Bode siggy root locus of the open loop pure gain roll damper will next be displayed to aid in placing the lead.

To continue, press F2

DISPLAY Standard root locus

If the pure gain roll damper root locus has standard topology the locus from the dutch roll pole goes into the low frequency "Wphi" complex zero in the roll due to aileron numerator.

If the root locus topology is nonstandard, the dutch roll locus does not go into the Wphi zero and instead departs from the low frequency, rigid body dynamics region asymptotically.

To view the conventional root locus of the open loop pure gain roll damper, press F2

DISPLAY Recommended lag

For the current roll damper lead placement, the lag should probably be at least 5 times higher in frequency. Thus the recommended lag inverse time constant is [roll damper lag inverse time constant(9,1)] rad/sec.

DISPLAY roll damper summary

Current roll damper

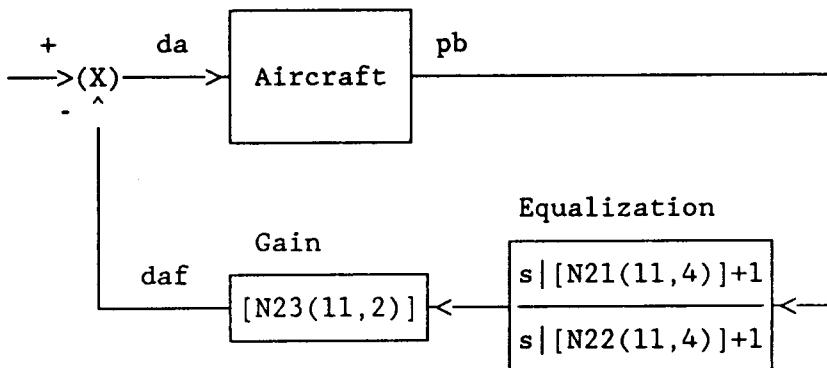

To continue, press F2

! DISPLAY model setup

! The system to be assessed consists of:

! To continue, Press F2

DISPLAY Assessment Summary

Assessment of the current roll damper design indicates that the roll subsidence mode time constant is [roll subsidence mode time constant assessment]

Thus the roll damper loop is [roll damper loop assessment]

To continue, Press F2

!  
END



**GAINSEL.PRL**

! "GAINSEL.PRL"

!

! SYSTEMS TECHNOLOGY, INC Hawthorne, CA

TITLE Loop Gain Selection Expert (GAINSEL) DISPLAY

This expert assists in the selection of gains in loop closures.

To continue, press F3

!.....

!

! Shared Facts Declarations

!

! The Shared Facts Declaration is stored in the "include" file named  
! "SHAREFCT.SHR" and combined with this knowledge base during compilation.

!

!\$SHAREFCT.SHR

!

!.....

!

! Data Type Declarations

!

!.....

!

! Parameter Initialization Statements

FORGET Specify loop gain directly

AND Loop gain has been specified directly

AND Examine Root Locus to set the gain

AND Loop gain has been specified from root locus

AND Examine Bode siggy to set the gain

AND Loop gain has been specified from Bode Siggy

AND Loop gain has been specified

AND Loop gain is defined

AND Terminate gain selection

AND Return to calling module

INIT St7:="C:\STI"

AND St8:="CC.EXE"

AND St51:="@ROOTLOC.MAC"

AND St52:="@BODESIG.MAC"

REINIT St7:="C:\STI"

AND St8:="CC.EXE"

AND St51:="@ROOTLOC.MAC"

AND St52:="@BODESIG.MAC"

!.....

!

! Control Element Selectors

THRESHOLD = 60  
CONFIDENCE OFF  
GOALSELECT ON  
UNKNOWN CONTINUE  
\$EXHAUSTV.SHR

!.....  
!  
! Multiattributed Objects Declarations  
!  
! The "MULTI" Declaration of multiattributed objects is stored in the  
! "include" file named "MULTI.SHR" and combined with this knowledge base  
! during compilation.

\$MULTI.SHR

!.....  
!  
! Goal Outline  
  
1. Specify loop gain directly  
  1.1 Loop gain has been specified directly  
    1.1.1 Loop gain is defined  
  
2. Examine Root Locus to set the gain  
  2.1 Loop gain has been specified from root locus  
    2.1.1 Loop gain is defined  
  
3. Examine Bode Siggy to set the gain  
  3.1 Loop gain has been specified from Bode Siggy  
    3.1.1 Loop gain is defined  
  
4. Terminate gain selection  
  4.1 Return to calling module

!  
!-----  
!  
! Rules

!.....  
!  
! Rules for setting loop gain

RULE for obtaining loop gain  
IF Specify loop gain directly  
AND ASK Loop gain  
THEN Loop gain has been specified directly  
AND CYCLE

```
RULE for obtaining loop gain from root locus
IF Examine Root Locus to set the gain
AND ACTIVATE C:\STI\PROCALL.EXE
SEND St7
SEND St8
SEND St51
SEND Transfer function $$g filename
AND ASK Loop gain
THEN Loop gain has been specified from root locus
AND CYCLE
```

```
RULE for obtaining loop gain from Bode siggy
IF Examine Bode siggy to set the gain
AND ACTIVATE C:\STI\PROCALL.EXE
SEND St7
SEND St8
SEND St52
SEND Transfer function $$g filename
AND ASK Loop gain
THEN Loop gain has been specified from Bode Siggy
AND CYCLE
```

```
RULE for ending gain selection
IF Terminate gain selection
AND Current loop IS Yaw damper
THEN Return to calling module
AND Yaw damper gain is defined
AND CHAIN C:\FCSXPRT\YAWDMPR
ELSE Return to calling module
AND Roll damper gain is defined
AND CHAIN C:\FCSXPRT\ROLLDMPR
```

```
!-----
!  
! Information Display Text  
  
!  
END
```

**SYSMOD.PRL**

! "SYSMOD"

!

TITLE Creation of Augmented Aircraft Model (SYSMOD) DISPLAY

This expert generates a transfer function matrix model of the augmented aircraft.

To continue, press F3

!.....

!

! Shared Facts Declarations

!

! The Shared Facts Declaration is stored in the "include" file named  
! "SHAREFCT.SHR" and combined with this knowledge base during compilation.

!

! \$SHAREFCT.SHR

!

!.....

!

! Data Type Declarations

!

!.....

!

! Parameter Initialization Statements

!

INIT St1 :- "C:\FCSDAT"

AND St7 :- "C:\STI"

AND St8 :- "CC.EXE"

AND St23 :- "ROLLRFB.TF" ! Data file - roll rate feedback TF

AND St24 :- "\$\$G230" ! Program CC roll rate feedback TF name

AND St28 :- "YAWRFB.TF" ! Data file - yaw rate feedback TF

AND St29 :- "\$\$G220" ! Program CC yaw rate feedback TF name

AND St20 :- "@FCSMODEL.MAC" ! Creating the closed loop TF matrix

AND St21 :- "RFTRANS.TMP" ! Data file for effective yaw damper

AND St22 :- "\$\$P210" ! Program CC quad name for effective yaw damper

AND St25 :- "@OLTF.MAC" ! Creating open loop transfer functions macro

AND St33 :- "UROLLRFB.TF" ! Data file - unity gain roll rate feedback TF

AND St34 :- "\$\$G231" ! Program CC unity gain roll rate feedback TF name

AND St38 :- "UYAWRFB.TF" ! Data file - unity gain yaw rate feedback TF

AND St39 :- "\$\$G221" ! Program CC unity gain yaw rate feedback TF name

AND ZERO = 0

AND ONE = 1

AND TWO = 2

AND FIVE = 5

AND SIX = 6

AND SEVEN = 7

AND ELEVEN = 11

! AND NUM1 = .3 ! Roll rate feedback gain

! AND NUM2 = .2 ! (.2s+1) term for the roll rate feedback

```

!   AND NUM3 = .04           ! (.04s+1) term for the roll rate feedback
!   AND NUM4 = -.8          ! Yaw rate feedback gain
!   AND NUM5 = 1.5          ! (s+1.5) term for the yaw rate feedback
!   AND  $\theta_g$  = .2164      ! Rate gyro tilt angle

```

```

REINIT St1 := "C:\FCSDAT"
AND St7 := "C:\STI"
AND St8 := "CC.EXE"
AND St23 := "ROLLRFB.TF"    ! Data file - roll rate feedback TF
AND St24 := "$G230"         ! Program CC roll rate feedback TF name
AND St28 := "YAWRFB.TF"    ! Data file - yaw rate feedback TF
AND St29 := "$G220"         ! Program CC yaw rate feedback TF name
AND St20 := "@FCSMODEL.MAC" ! Creating the closed loop TF matrix
AND St21 := "RFTRANS.TMP"  ! Data file for effective yaw damper
AND St22 := "$P210"        ! Program CC quad name for effective yaw damper
AND St25 := "@OLTF.MAC"    ! Creating open loop transfer functions macro
AND St33 := "UROLLRFB.TF"  ! Data file - unity gain roll rate feedback TF
AND St34 := "$G231"        ! Program CC unity gain roll rate feedback TF name
AND St38 := "UYAWRFB.TF"   ! Data file - unity gain yaw rate feedback TF
AND St39 := "$G221"        ! Program CC unity gain yaw rate feedback TF name
AND ZERO = 0
AND ONE = 1
AND TWO = 2
AND FIVE = 5
AND SIX = 6
AND SEVEN = 7
AND ELEVEN = 11

```

```

!
!
!.....
!

```

! Control Element Selectors

```

THRESHOLD = 100
CONFIDENCE OFF
GOALSELECT ON
UNKNOWN CONTINUE
$EXHAUSTV.SHR

```

```

!.....
!

```

! Multiattributed Objects Declarations

```

! The "MULTI" Declaration of multiattributed objects is stored in the
! "include" file named "MULTI.SHR" and combined with this knowledge base
! during compilation.

```

\$MULTI.SHR

```

!.....
!

```

!  
!     Goal Outline

1. System model has been generated
  - 1.1 Return to calling expert

---

!  
!     Rules  
!

RULE for system model parameter setup  
IF System model must be generated  
AND KPF := Roll rate blending coefficient  
AND KRF := Yaw rate blending coefficient  
AND NUM2 := 1/(Roll damper lead inverse time constant)  
AND NUM3 := 1/(Roll damper lag inverse time constant)  
AND NUM1 := Roll damper gain  
AND NUM5 := Yaw damper washout inverse time constant  
AND NUM4 := yaw damper gain  
THEN FCS parameters are set

RULE for calling Program  
IF FCS parameters are set  
!  
!  
!         Writing the roll rate feedback file that DATOCC.EXE  
!         will convert to \$\$G230  
!  
!

AND WRITE C:\FCSDAT\ROLLRFB.TF  
DATA SEVEN  
DATA ELEVEN  
DATA TWO  
DATA ZERO  
DATA NUM1  
DATA ONE  
DATA NUM2  
DATA ONE  
DATA ONE  
DATA ONE  
DATA NUM3  
DATA ONE  
AND ACTIVATE C:\STI\DATOCC.EXE  
SEND St1  
SEND St23  
SEND St7  
SEND St24

!  
!  
!         Writing the yaw rate feedback file that DATOCC.EXE  
!         will convert to \$\$G220



```

!
!
AND WRITE C:\FCSDAT\YAWRFB.TF
DATA SEVEN
DATA ELEVEN
DATA TWO
DATA ZERO
DATA NUM4
DATA ONE
DATA ONE
DATA ZERO
DATA ONE
DATA ONE
DATA ONE
DATA NUM5
AND ACTIVATE C:\STI\DATOCC.EXE
SEND St1
SEND St28
SEND St7
SEND St29
!
!
!           Writing the effective yaw rate file that DATOCC.EXE
!           will convert to $$P210
!
!
AND WRITE C:\FCSDAT\RFTRANS.TMP
DATA ZEPO
DATA TWO
DATA TWO
DATA ONE
DATA ZERO
DATA KPF
DATA KRF
AND ACTIVATE C:\STI\DATOCC.EXE
SEND St1
SEND St21
SEND St7
SEND St22
!
!
!           Creating the closed loop system using the Program CC macro FCSSMODEL.MAC
!
!
AND ACTIVATE C:\STI\PROCALL.EXE
SEND St7
SEND St8
SEND St20
THEN System model has been generated

```

```

!RULE for creating open loop transfer functions
!IF System model has been generated
!THEN open loop transfer functions have been created
!
!
!           Writing the unity gain roll rate feedback file that DATOCC.EXE
!           will convert to $$G231
!
!
AND WRITE C:\FCSDAT\UROLLRFB.TF
DATA SEVEN
DATA ELEVEN
DATA TWO
DATA ZERO
DATA ONE
DATA ONE
DATA NUM2
DATA ONE
DATA ONE
DATA ONE
DATA NUM3
DATA ONE
AND ACTIVATE C:\STI\DATOCC.EXE
SEND St1
SEND St33
SEND St7
SEND St34
!
!
!           Writing the unity gain yaw rate feedback file that DATOCC.EXE
!           will convert to $$G221
!
!
AND WRITE C:\FCSDAT\UYAWRFB.TF
DATA SEVEN
DATA ELEVEN
DATA TWO
DATA ZERO
DATA ONE
DATA ONE
DATA ONE
DATA ZERO
DATA ONE
DATA ONE
DATA ONE
DATA NUM5
AND ACTIVATE C:\STI\DATOCC.EXE
SEND St1
SEND St38
SEND St7
SEND St39
!

```

```
!  
!       Creating the open loop system using the Program CC macro OLF.MAC  
!  
!  
AND ACTIVATE C:\STI\PROCALL.EXE  
SEND St7  
SEND St8  
SEND St25  
  
RULE for returning to DESIGN  
IF Expert requesting SYSMOD IS DESIGN expert  
THEN Return to calling expert  
AND CHAIN C:\FCSXPRT\DESIGN  
  
RULE for returning to YAWDMPR  
IF Expert requesting SYSMOD IS YAWDMPR expert  
THEN Return to calling expert  
AND CHAIN C:\FCSXPRT\YAWDMPR  
  
RULE for returning to ROLLDMPR  
IF Expert requesting SYSMOD IS ROLLDMPR expert  
THEN Return to calling expert  
AND CHAIN C:\FCSXPRT\ROLLDMPR  
  
!  
END
```

**TFEXT.PRL**

! "TFEXT.PRL"

!

! SYSTEMS TECHNOLOGY, INC Hawthorne, CA

TITLE Transfer Function Extraction (TFEXT) DISPLAY

This expert transfers a specified system transfer function, in factored form, to an expert.

To continue, press F3

! This knowledge base functions as a subroutine to transfer transfer  
! functions for the augmented airframe system (generated by the SYSMOD  
! expert) to LEVEL5. It is assumed that SYSMOD has just placed the  
! augmented system transfer functions in Program CC \$\$G filenames.

!.....

!

! Shared Facts Declarations

!

! The Shared Facts Declaration is stored in the "include" file named  
! "SHAREFCT.SHR" and combined with this knowledge base during compilation.

!

\$SHAREFCT.SHR

!

!.....

!

! Data Type Declarations

!

NUMERIC Number of numerical real zeros  
AND Number of numerical complex zero pairs  
AND Number of numerical real poles  
AND Number of numerical complex pole pairs  
AND Number of nonminimum phase numerical real zeros  
AND Number of nonminimum phase numerical complex zero pairs  
AND Number of unstable numerical real poles  
AND Number of unstable numerical complex pole pairs  
AND High frequency gain  
AND Inverse time constant of real zero #1  
AND Inverse time constant of real zero #2  
AND Inverse time constant of real zero #3  
AND Inverse time constant of real zero #4  
AND Inverse time constant of real zero #5  
AND Inverse time constant of real zero #6  
AND Damping ratio of complex zero pair #1  
AND Natural frequency of complex zero pair #1  
AND Damping ratio of complex zero pair #2  
AND natural frequency of complex zero pair #2  
AND Damping ratio of complex zero pair #3

AND natural frequency of complex zero pair #3  
AND Damping ratio of complex zero pair #4  
AND natural frequency of complex zero pair #4  
AND Damping ratio of complex zero pair #5  
AND natural frequency of complex zero pair #5  
AND Damping ratio of complex zero pair #6  
AND natural frequency of complex zero pair #6  
AND Inverse time constant of real pole #1  
AND Inverse time constant of real pole #2  
AND Inverse time constant of real pole #3  
AND Inverse time constant of real pole #4  
AND Inverse time constant of real pole #5  
AND Inverse time constant of real pole #6  
AND Damping ratio of complex pole pair #1  
AND natural frequency of complex pole pair #1  
AND Damping ratio of complex pole pair #2  
AND natural frequency of complex pole pair #2  
AND Damping ratio of complex pole pair #3  
AND natural frequency of complex pole pair #3  
AND Damping ratio of complex pole pair #4  
AND natural frequency of complex pole pair #4  
AND Damping ratio of complex pole pair #5  
AND natural frequency of complex pole pair #5  
AND Damping ratio of complex pole pair #6  
AND natural frequency of complex pole pair #6  
AND Inverse time constant of bare airframe real pole #1  
AND Inverse time constant of bare airframe real pole #2  
AND Damping ratio of bare airframe complex pole pair #1  
AND Natural frequency of bare airframe complex pole pair #1

STRING Transfer function \$\$g filename  
AND St35  
AND St36  
AND St37

!.....  
!  
!     Parameter Initialization Statements  
!  
!.....  
!  
!     Control Element Selectors

THRESHOLD - 60  
CONFIDENCE OFF  
GOALSELECT ON  
UNKNOWN CONTINUE  
\$EXHAUSTV.SHR

!.....  
!  
!     Multiattributed Objects Declarations

!  
! The "MULTI" Declaration of multiattributed objects is stored in the  
! "include" file named "MULTI.SHR" and combined with this knowledge base  
! during compilation.

\$MULTI.SHR

!.....  
!  
! Goal Outline

1. Return to calling expert

!-----  
!  
! Rules  
!  
!.....

RULE for reading specified system transfer function into expert system  
! Activates program "TFCCL5" to convert specified system transfer function  
! (in Program CC "\$\$g" file) to LEVEL 5 format stored in file TFTRANS.PRM.  
! This file is then read into the knowledge base.  
St35 := "C:\STI\\$\$" ! Subdirectory containing files and macros below  
St36 := Transfer function \$\$g filename  
St37 := "C:\FCSDAT\TFTRANS.PRM" ! Transfer function file in LEVEL 5 format  
IF System model has been generated  
AND ACTIVATE C:\STI\TFCCL5.EXE  
SEND St35  
SEND St36  
SEND St37  
THEN Specified system transfer function has been transmitted  
! File TFTRANS.PRM contains the transfer function in LEVEL5 format  
! Zeros and poles are stored in order of increasing frequency  
AND READ C:\FCSDAT\TFTRANS.PRM  
DATA Number of numerical real zeros  
DATA Number of numerical complex zero pairs  
DATA Number of numerical real poles  
DATA Number of numerical complex pole pairs  
DATA Number of nonminimum phase numerical real zeros  
DATA Number of nonminimum phase numerical complex zero pairs  
DATA Number of unstable numerical real poles  
DATA Number of unstable numerical complex pole pairs  
DATA High frequency gain  
DATA Inverse time constant of real zero #1  
DATA Inverse time constant of real zero #2  
DATA Inverse time constant of real zero #3  
DATA Inverse time constant of real zero #4  
DATA Inverse time constant of real zero #5  
DATA Inverse time constant of real zero #6  
DATA Damping ratio of complex zero pair #1  
DATA natural frequency of complex zero pair #1

DATA Damping ratio of complex zero pair #2  
DATA natural frequency of complex zero pair #2  
DATA Damping ratio of complex zero pair #3  
DATA natural frequency of complex zero pair #3  
DATA Damping ratio of complex zero pair #4  
DATA natural frequency of complex zero pair #4  
DATA Damping ratio of complex zero pair #5  
DATA natural frequency of complex zero pair #5  
DATA Damping ratio of complex zero pair #6  
DATA natural frequency of complex zero pair #6  
DATA Inverse time constant of real pole #1  
DATA Inverse time constant of real pole #2  
DATA Inverse time constant of real pole #3  
DATA Inverse time constant of real pole #4  
DATA Inverse time constant of real pole #5  
DATA Inverse time constant of real pole #6  
DATA Damping ratio of complex pole pair #1  
DATA natural frequency of complex pole pair #1  
DATA Damping ratio of complex pole pair #2  
DATA natural frequency of complex pole pair #2  
DATA Damping ratio of complex pole pair #3  
DATA natural frequency of complex pole pair #3  
DATA Damping ratio of complex pole pair #4  
DATA natural frequency of complex pole pair #4  
DATA Damping ratio of complex pole pair #5  
DATA natural frequency of complex pole pair #5  
DATA Damping ratio of complex pole pair #6  
DATA natural frequency of complex pole pair #6  
AND DISPLAY TF data

RULE for returning to calling expert  
IF Specified system transfer function has been transmitted  
AND Calling expert IS YAWDMPR expert  
THEN Return to calling expert  
AND CHAIN C:\FCSXPRT\YAWDMPR

RULE for returning to calling expert  
IF Specified system transfer function has been transmitted  
AND Calling expert IS ROLLDMPR expert  
THEN Return to calling expert  
AND CHAIN C:\FCSXPRT\ROLLDMPR

!-----

!

! Information Display Text

DISPLAY TF data  
Number of real zeros - [Number of numerical real zeros]  
Number of complex zero pairs - [Number of numerical complex zero pairs]  
Number of real poles - [Number of numerical real poles]  
Number of complex poles - [Number of numerical complex pole pairs]  
Number of nonminimum phase real zeros - [Number of nonminimum phase numerical real zeros]



Number of nonminimum phase complex zero - [Number of nonminimum phase numerical complex zero pairs]  
Number of unstable real poles - [Number of unstable numerical real poles]  
Number of unstable complex poles - [Number of unstable numerical complex pole pairs]  
High frequency gain - [High frequency gain]

Zeros:

Real - [Inverse time constant of real zero #1]  
Real - [Inverse time constant of real zero #2]  
Real - [Inverse time constant of real zero #3]  
Real - [Inverse time constant of real zero #4]  
Real - [Inverse time constant of real zero #5]  
Real - [Inverse time constant of real zero #6]

Damping ratio - [Damping ratio of complex zero pair #1]  
Frequency - [natural frequency of complex zero pair #1]  
Damping ratio - [Damping ratio of complex zero pair #2]  
Frequency - [natural frequency of complex zero pair #2]  
Damping ratio - [Damping ratio of complex zero pair #3]  
Frequency - [natural frequency of complex zero pair #3]  
Damping ratio - [Damping ratio of complex zero pair #4]  
Frequency - [natural frequency of complex zero pair #4]  
Damping ratio - [Damping ratio of complex zero pair #5]  
Frequency - [natural frequency of complex zero pair #5]  
Damping ratio - [Damping ratio of complex zero pair #6]  
Frequency - [natural frequency of complex zero pair #6]

Poles:

Real - [Inverse time constant of real pole #1]  
Real - [Inverse time constant of real pole #2]  
Real - [Inverse time constant of real pole #3]  
Real - [Inverse time constant of real pole #4]  
Real - [Inverse time constant of real pole #5]  
Real - [Inverse time constant of real pole #6]

Damping ratio - [Damping ratio of complex pole pair #1]  
Frequency - [natural frequency of complex pole pair #1]  
Damping ratio - [Damping ratio of complex pole pair #2]  
Frequency - [natural frequency of complex pole pair #2]  
Damping ratio - [Damping ratio of complex pole pair #3]  
Frequency - [natural frequency of complex pole pair #3]  
Damping ratio - [Damping ratio of complex pole pair #4]  
Frequency - [natural frequency of complex pole pair #4]  
Damping ratio - [Damping ratio of complex pole pair #5]  
Frequency - [natural frequency of complex pole pair #5]  
Damping ratio - [Damping ratio of complex pole pair #6]  
Frequency - [natural frequency of complex pole pair #6]

!

END

**ROOTID.PRL**

! "ROOTID.PRL"

!

! SYSTEMS TECHNOLOGY, INC Hawthorne, CA

TITLE Augmented Aircraft Pole and Zero Identification (ROOTID) DISPLAY

This expert manages the physical identification of poles and zeros of an aircraft with complete or partial augmentation.

To continue, press F3

! The ROOTID expert acts on the current system transfer function in FCX.  
! The TFEXT knowledge base must be exercised properly before ROOTID is called.  
!

! .....

!

! Shared Facts Declarations

!

! The Shared Facts Declaration is stored in the "include" file named "SHAREFCT.SHR" and combined with this knowledge base during compilation.  
!

! \$SHAREFCT.SHR

!

! .....

!

! Data Type Declarations

!

! .....

!

! Parameter Initialization Statements

!

! .....

!

! Control Element Selectors

THRESHOLD - 60

CONFIDENCE OFF

GOALSELECT ON

UNKNOWN CONTINUE

! \$EXHAUSTV.SHR

! .....

!

! Multiattributed Objects Declarations

!

! The "MULTI" Declaration of multiattributed objects is stored in the "include" file named "MULTI.SHR" and combined with this knowledge base during compilation.  
!

\$MULTI.SHR

!.....

!

! Goal Outline

1. Return to calling expert

!-----

!

! Rules

!

!.....

! Rules for identifying poles

RULE for poles and zeros of open loop aircraft  
IF Specified system transfer function has been transmitted  
AND Current architecture IS RD&YD  
AND Roll damper loop connection IS open  
AND Yaw damper loop connection IS open  
AND Transfer function \$\$g filename = "G26032"  
THEN System poles are identified  
AND Wrs := natural frequency of complex zero pair #1  
AND DISPLAY Pole summary 0

RULE for poles and zeros of open loop aircraft  
IF Specified system transfer function has been transmitted  
AND Current architecture IS RD&YD  
AND Roll damper loop connection IS open  
AND Yaw damper loop connection IS open  
AND Transfer function \$\$g filename = "G26052"  
THEN System poles are identified  
AND DISPLAY Pole summary 0

RULE for poles with yaw damper only  
IF Specified system transfer function has been transmitted  
AND Current architecture IS RD&YD  
AND Roll damper loop connection IS open  
AND Yaw damper loop connection IS closed  
THEN System poles are identified  
AND ITs' := Inverse time constant of real pole #1  
AND ITr' := Inverse time constant of real pole #2  
AND Zd' := Damping ratio of complex pole pair #1  
AND Wd' := natural frequency of complex pole pair #1  
AND DISPLAY Pole summary 1

RULE for poles with yaw and roll damper  
IF Specified system transfer function has been transmitted  
AND Current architecture IS RD&YD  
AND Roll damper loop connection IS closed

```

AND Yaw damper loop connection IS closed
THEN System poles are identified
AND ITs'' := Inverse time constant of real pole #1
AND ITr'' := Inverse time constant of real pole #2
AND Zd'' := Damping ratio of complex pole pair #1
AND Wd'' := natural frequency of complex pole pair #1
AND DISPLAY Pole summary 2

```

```

RULE for returning to calling expert
IF System poles are identified
AND Calling expert IS YAWDMPR expert
THEN Return to calling expert
AND CHAIN C:\FCSXPRT\YAWDMPR

```

```

RULE for returning to calling expert
IF System poles are identified
AND Calling expert IS ROLLDMPR expert
THEN Return to calling expert
AND CHAIN C:\FCSXPRT\ROLLDMPR

```

---

```

!
!
! Information Display Text

```

```

DISPLAY Pole summary 0

```

```

All FCS loops are OPEN

```

```

Spiral mode inverse time constant      - [ITs] rad|sec
Roll subsidence mode inverse time constant - [ITr] rad|sec
Dutch roll damping ratio                - [Zd]
Dutch roll undamped natural frequency  - [Wd] rad|sec

rf|dr complex zero frequency           - [Wrs] rad|sec

```

To continue, press F2

```

DISPLAY Pole summary 1

```

```

1 loop is closed

```

```

Spiral mode inverse time constant      - [ITs'] rad|sec
Roll subsidence mode inverse time constant - [ITr'] rad|sec
Dutch roll damping ratio                - [Zd']
Dutch roll undamped natural frequency  - [Wd'] rad|sec

```

To continue, press F2

```

DISPLAY Pole summary 2

```

```

2 loops are closed

```

Spiral mode inverse time constant - [ITs''] rad|sec  
Roll subsidence mode inverse time constant - [ITr''] rad|sec  
Dutch roll damping ratio - [Zd'']  
Dutch roll undamped natural frequency - [Wd''] rad|sec

To continue, press F2

!  
END

**ASSESS.PRL**

! "ASSESS.PRL"

!

TITLE AIRCRAFT DYNAMICS ASSESSMENT (ASSESS) DISPLAY

This expert assists in the assessment of the current system -- aircraft plus the loops presently designed for the current architecture -- with respect to appropriate design requirements.

To continue, PRESS F3

!.....

!

! Shared Facts Declarations

!

! The Shared Facts Declaration is stored in the "include" file named "SHAREFCT.SHR" and combined with this knowledge base during compilation.

!

!\$SHAREFCT.SHR

!

!.....

!

! Data Type Declarations

!

!.....

!

! Parameter Initialization Statements

!

!.....

!

! Control Element Selectors

THRESHOLD - 100

CONFIDENCE OFF

GOALSELECT ON

UNKNOWN CONTINUE

!\$EXHAUSTV.SHR

!.....

!

! Multiattributed Objects Declarations

!

! The "MULTI" Declaration of multiattributed objects is stored in the "include" file named "MULTI.SHR" and combined with this knowledge base during compilation.

!



\$MULTI.SHR

!.....  
!  
! Goal Outline

1. Dynamics variables are set
  - 1.1 Requirement comparison is complete

!-----  
!  
! Rules  
!.....

! Rules for setting dynamics variables  
!

RULE for open loop aircraft  
IF Yaw damper loop connection IS open  
AND Roll damper loop connection IS open  
THEN Dynamics variables are set  
AND spiral mode inverse time constant := ITs  
AND roll subsidence mode inverse time constant := ITr  
AND Dutch roll damping ratio := Zd  
AND Dutch roll natural frequency := Wd

RULE for only yaw damper closed  
IF Yaw damper loop connection IS closed  
AND Roll damper loop connection IS open  
THEN Dynamics variables are set  
AND spiral mode inverse time constant := ITs'  
AND roll subsidence mode inverse time constant := ITr'  
AND Dutch roll damping ratio := Zd'  
AND Dutch roll natural frequency := Wd'

RULE for yaw damper and roll damper closed  
IF Yaw damper loop connection IS closed  
AND Roll damper loop connection IS closed  
THEN Dynamics variables are set  
AND spiral mode inverse time constant := ITs''  
AND roll subsidence mode inverse time constant := ITr''  
AND Dutch roll damping ratio := Zd''  
AND Dutch roll natural frequency := Wd''

!.....  
!  
! Rules for assessing requirements

RULE for assessing dutch roll damping ratio  
IF dutch roll damping ratio >= dutch roll damping ratio spec  
THEN dutch roll damping ratio assessment IS adequate

AND dutch roll damping ratio has been assessed  
ELSE dutch roll damping ratio assessment IS too low  
AND dutch roll damping ratio has been assessed

RULE for assessing dutch roll mode  
IF dutch roll damping ratio assessment IS adequate  
! AND dutch roll natural frequency IS adequate  
THEN dutch roll mode dynamics are adequate  
AND dutch roll mode has been compared with the requirements  
AND DISPLAY Dutch roll summary  
ELSE NOT dutch roll mode dynamics are adequate  
AND dutch roll mode has been compared with the requirements  
AND DISPLAY Dutch roll summary

RULE for assessing roll subsidence mode  
IF roll subsidence mode inverse time constant  $\geq$  :  
 $1/(\text{Roll subsidence mode time constant spec})$   
THEN roll subsidence mode time constant assessment IS adequate  
AND roll mode time constant has been assessed  
ELSE roll subsidence mode time constant assessment IS too high  
AND roll mode time constant has been assessed

RULE for assessing roll subsidence mode  
IF roll subsidence mode time constant assessment IS adequate  
THEN roll subsidence mode dynamics are adequate  
AND roll subsidence mode has been assessed  
AND DISPLAY Roll subsidence summary  
ELSE NOT roll subsidence mode dynamics are adequate  
AND roll subsidence mode has been assessed  
AND DISPLAY Roll subsidence summary

RULE for assessing modal characteristics  
IF dutch roll mode dynamics are adequate  
AND roll subsidence mode dynamics are adequate  
! AND spiral mode dynamics are adequate  
THEN modal dynamics are adequate  
AND system has been compared with the requirements  
AND DISPLAY modal dynamics summary  
ELSE NOT modal dynamics are adequate  
AND system has been compared with the requirements  
AND DISPLAY modal dynamics summary

!.....  
!  
! Rules for determining the next activity

RULE for determining if requirement comparison has been completed  
IF system has been compared with the requirements  
AND Current loop IS yaw damper  
THEN requirement comparison is complete  
! AND DISPLAY requirement comparison results  
AND FORGET Yaw damper loop assessment

AND CHAIN C:\FCSXPRT\YAWDMPR

RULE for determining if requirement comparison has been completed  
IF system has been compared with the requirements  
AND Current loop IS roll damper  
THEN requirement comparison is complete  
! AND DISPLAY requirement comparison results  
AND FORGET Roll damper loop assessment  
AND CHAIN C:\FCSXPRT\ROLLDMPR

!-----  
!  
! Information Display Text  
!

DISPLAY Dutch roll summary

Comparison of the current system with the requirements indicates that the

Dutch roll damping ratio is [dutch roll damping ratio assessment]

Thus it is [dutch roll mode dynamics are adequate] that the dutch roll mode dynamics are adequate.

To continue, press F2

DISPLAY Roll subsidence summary

Comparison of the current system with the requirements indicates that the

Roll subsidence mode time constant is [roll subsidence mode time constant assessment]

Thus it is [roll subsidence mode dynamics are adequate] that the roll subsidence mode dynamics are adequate.

To continue, press F2

DISPLAY modal dynamics summary

Comparison of the current system with the requirements indicates that it is [modal dynamics are adequate] that the modal dynamics are adequate.

To continue, press F2

END



# Report Documentation Page

|  |  |  |   |  |           |
|--|--|--|---|--|-----------|
| 1. Report No.<br>NASA CR-181726  |  | 2. Government Accession No.                          |   | 3. Recipient's Catalog No.   |           |
| 4. Title and Subtitle<br>Advanced Piloted Aircraft Flight Control System<br>Design Methodology<br>Volume II: The FCX Flight Control Design<br>Expert System  |  |  |   | 5. Report Date<br>October 1988   |           |
|  |  |  |   | 6. Performing Organization Code  |           |
| 7. Author(s)<br><br>Thomas T. Myers and Duane T. McRuer  |  |  |   | 8. Performing Organization Report No.<br><br>STI TR-1228-1   |           |
|  |  |  |   | 10. Work Unit No.<br><br>505-66-01-02  |           |
| 9. Performing Organization Name and Address<br><br>Systems Technology, Inc.<br>13766 South Hawthorne Boulevard<br>Hawthorne, CA 90250-7083   |  |  |   | 11. Contract or Grant No.<br><br>NAS1-17987  |           |
|  |  |  |   | 13. Type of Report and Period Covered<br><br>Contractor Report   |           |
| 12. Sponsoring Agency Name and Address<br><br>National Aeronautics and Space Administration<br>Langley Research Center<br>Hampton, VA 23665-5225   |  |  |   | 14. Sponsoring Agency Code   |           |
|  |  |  |   | 15. Supplementary Notes<br><br>Langley Technical Monitor: Jarrell R. Elliott<br>SBIR Phase II Final Report |           |
| 16. Abstract<br><br>This report presents and illustrates the development of a comprehensive and eclectic methodology for conceptual and preliminary design of flight control systems. The methodology is focused on the design stages starting with the layout of system requirements and ending when some viable competing system architectures (feedback control structures) are defined. The approach is centered on the human pilot and the aircraft as both the sources of, and the keys to the solution of, many flight control problems. The methodology relies heavily on computational procedures which are highly interactive with the design engineer. To maximize effectiveness, these techniques, as selected and modified to be used together in the methodology, form a cadre of computational tools specifically tailored for integrated flight control system preliminary design purposes. The computer aids are all based on IBM PC compatible machines and most are now commercially available. This helps make the methodology as broadly available and useful as possible instead of simply another isolated approach.<br><br>Go TO PAGE 11 |  |  |   |  |           |
| 17. Key Words (Suggested by Author(s))<br>Artificial intelligence (AI)<br>Expert systems<br>Flight control system design<br>Knowledge-based design<br>Natural language interface   |  |  | 18. Distribution Statement<br><br>Unclassified - Unlimited<br><br>Subject Category 08 |  |           |
| 19. Security Classif. (of this report)<br>Unclassified   |  | 20. Security Classif. (of this page)<br>Unclassified |   | 21. No. of pages<br>190  | 22. Price |