



Utilization of Automated Oil Spill Detection Technology for Clean Water Compliance & Spill Discharge Prevention

by

Chris R. Chase, Steven VanBibber

of

InterOcean Systems, Inc.

San Diego, California, USA

chrisc@interoceansystems.com

(858) 565-8400

Why Use Remote Oil Spill Sensors?



- **Protect Business Interests via Remote Self-Monitoring**
- **Compliance w/ SPCC and other Clean Water Regs**
-for example CFR 40 112.7, 112.8, etc.
- **Best Management Practice**
- **Good Engineering Practice**
- **Around-the-Clock Protection Against Spill Going Unnoticed for Any Length of Time!**

Development Objectives



Early Prototype ~ Spring 2004

Early Warning Device for All Types of Oil Spills

- ✂ Preventative Countermeasure
- ✂ Analogous to a “Smoke Alarm” for Oil Spills
- ✂ Surface/Near-Surface
- ✂ Highly-Sensitive Sheen Detection
- ✂ Broad Range of Oil Pollutants
- ✂ Freshwater or Marine Environment

Non-Contact Sensor

- ✂ Optical Sensor
- ✂ Low Maintenance, Non Fouling
- ✂ Easy to Use and Install

Development Objectives



1st Production Unit ~ Summer 2004

Automated

- Remote Monitoring
- Network Addressable

Versatile

- Adaptable for Varied Applications & Settings

Exceed Tidal Range

- +/- 5 Meters Above Target

Affordable

- Commercially Viable
- Turnkey System

Stages of New Sensor

Development



Current Production Unit ~ Spring 2006

- Market Research
- R & D
- Build Prototypes
- Lab & Field Testing
- Apply Lessons Learned
- 1st Production Units, #1,2,3...
- Ongoing Sensor/System Improvements Based on Extensive Customer Feedback **(Present Phase)**

Theory of Operation

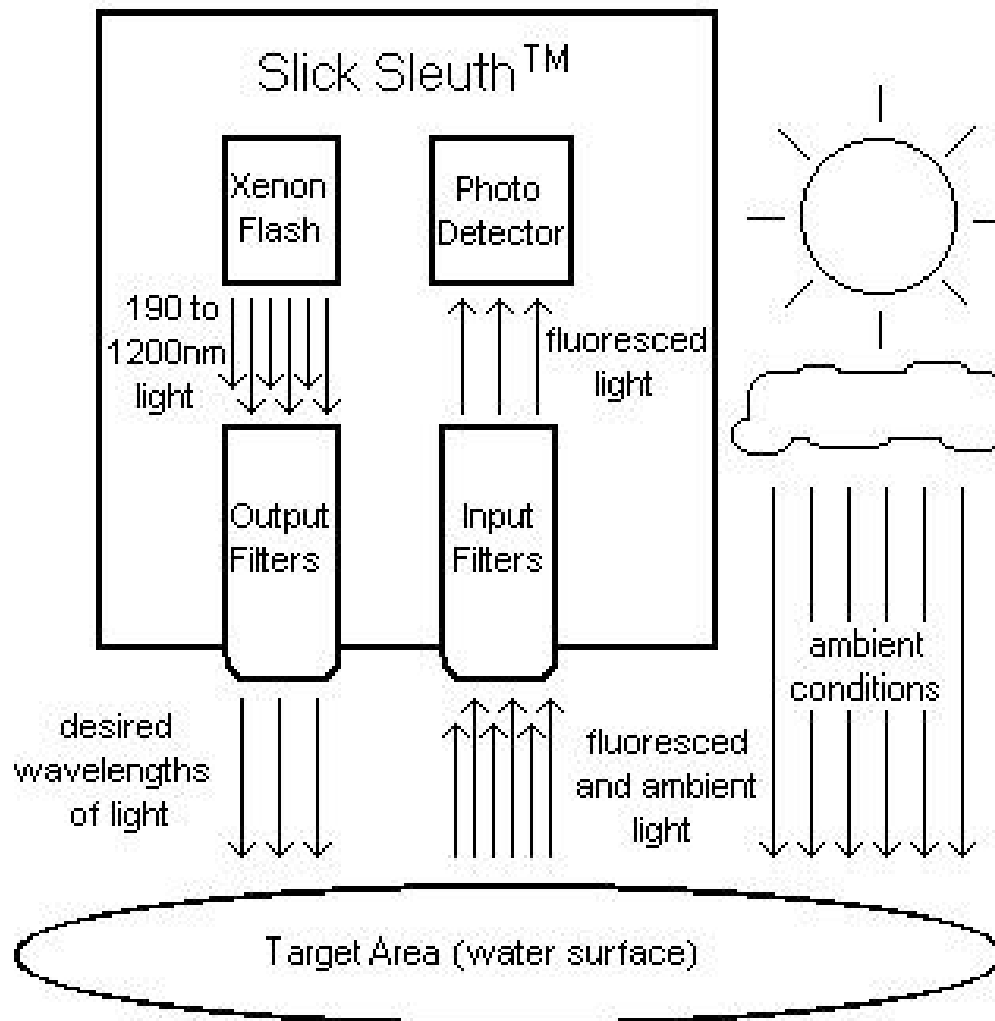

Basic Operation

Theory of Operation

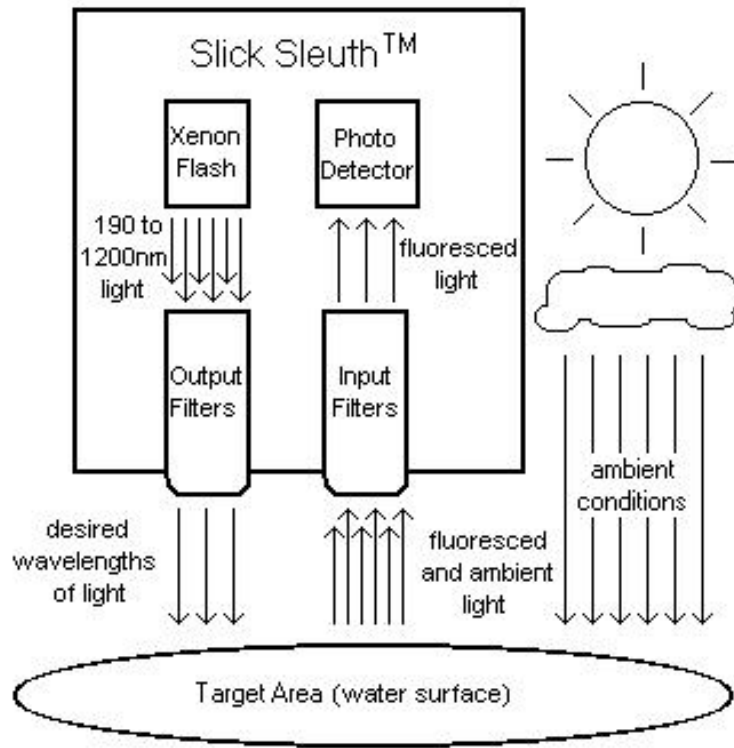

Basic Operation

- **Differential Measurement**
Anomaly Detection
- **Rejects Ambient Conditions**
i.e. Water Surface, Sunlight, Foam, etc.
- **User Adjustable Sensitivity**
Baseline + Offset = Detection Threshold
- **Discrete or Scaled Output**
Yes/No Detection vs.
Proportional Signal (0-30,000 counts, 0-20mA)

Theory of Operation

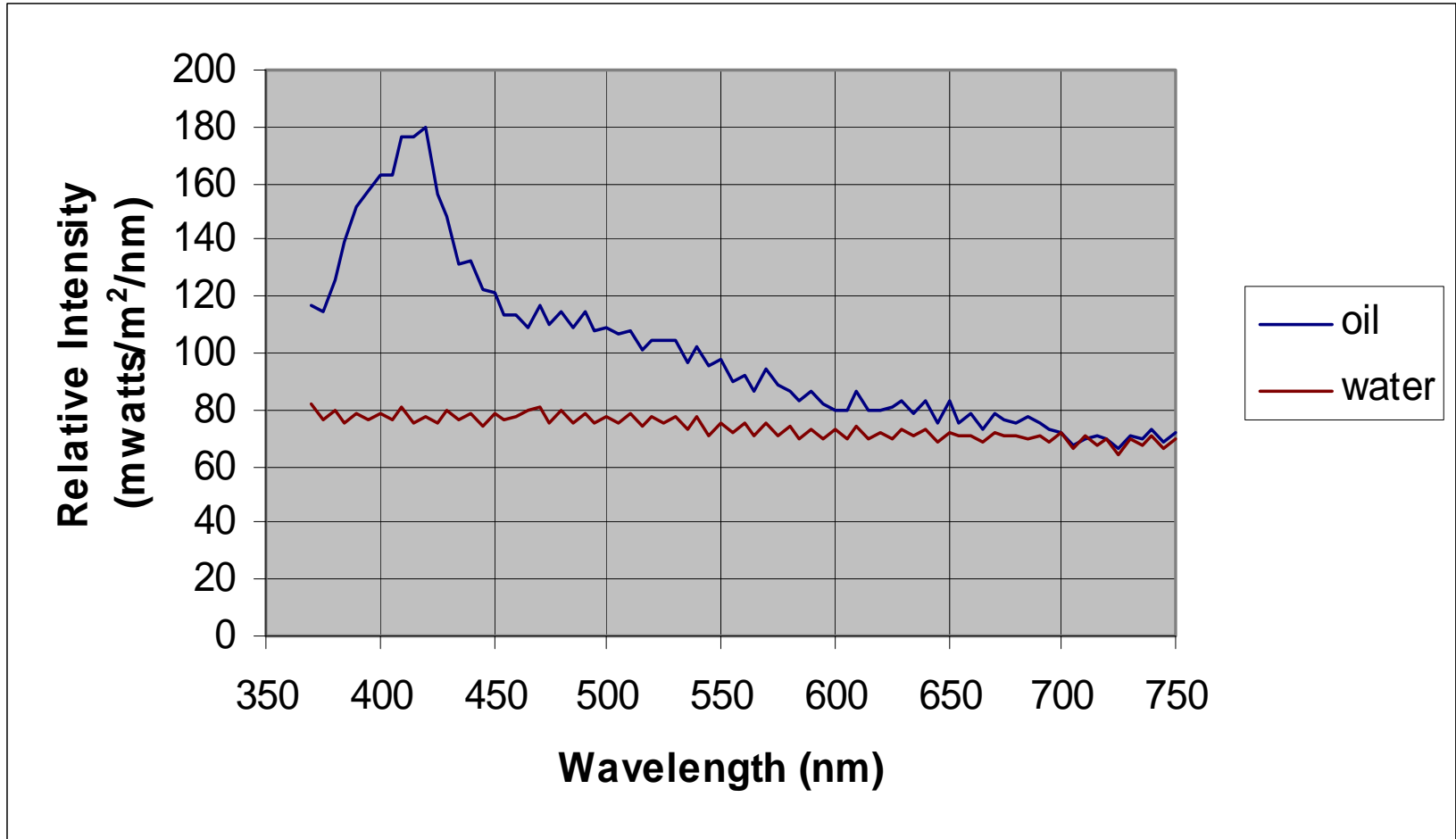

Characterizing Detection of Hydrocarbons Using UV Light Source

Theory of Operation

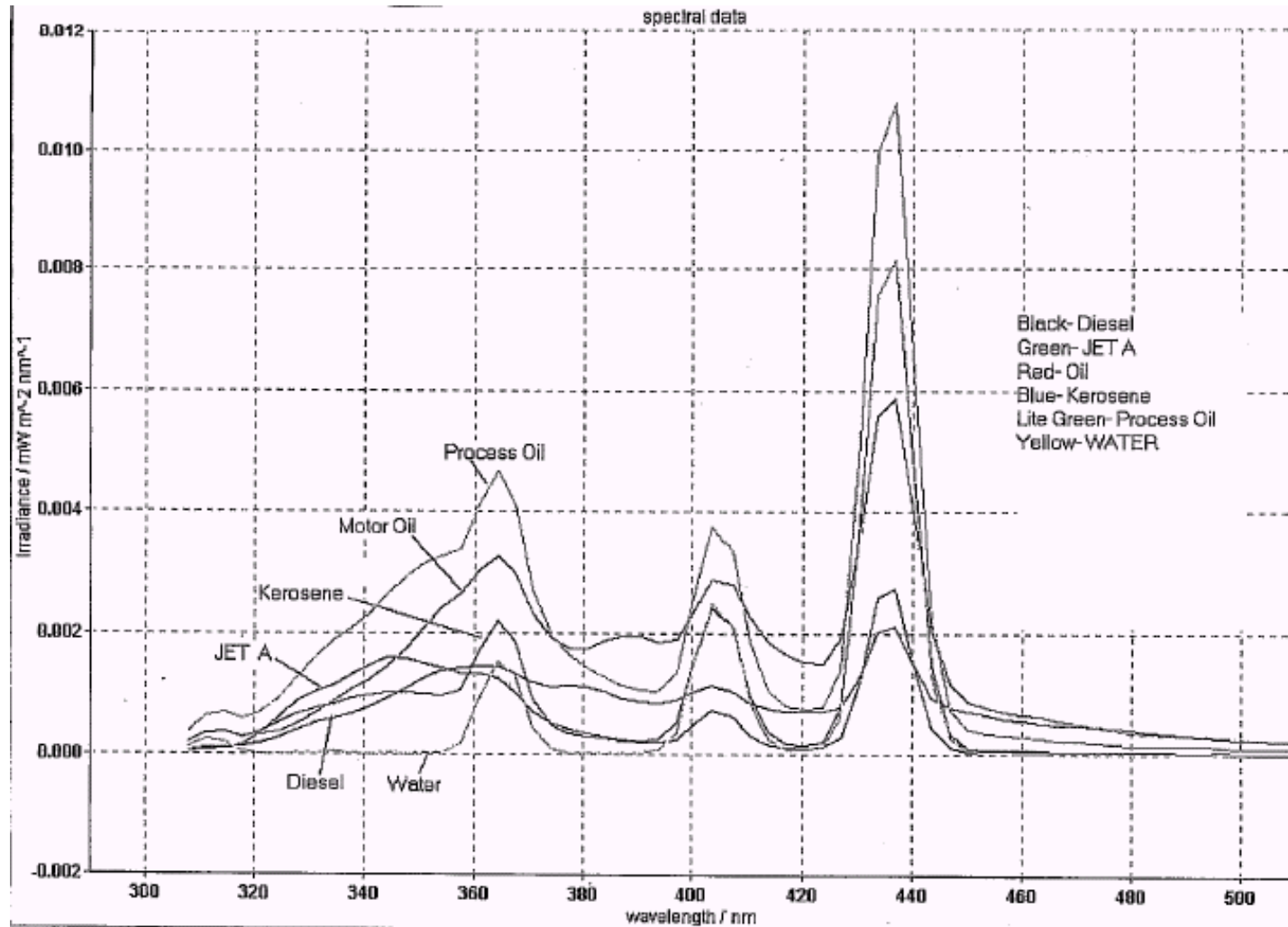

Characterizing Detection of Hydrocarbons Using UV Light Source

Typical System Features

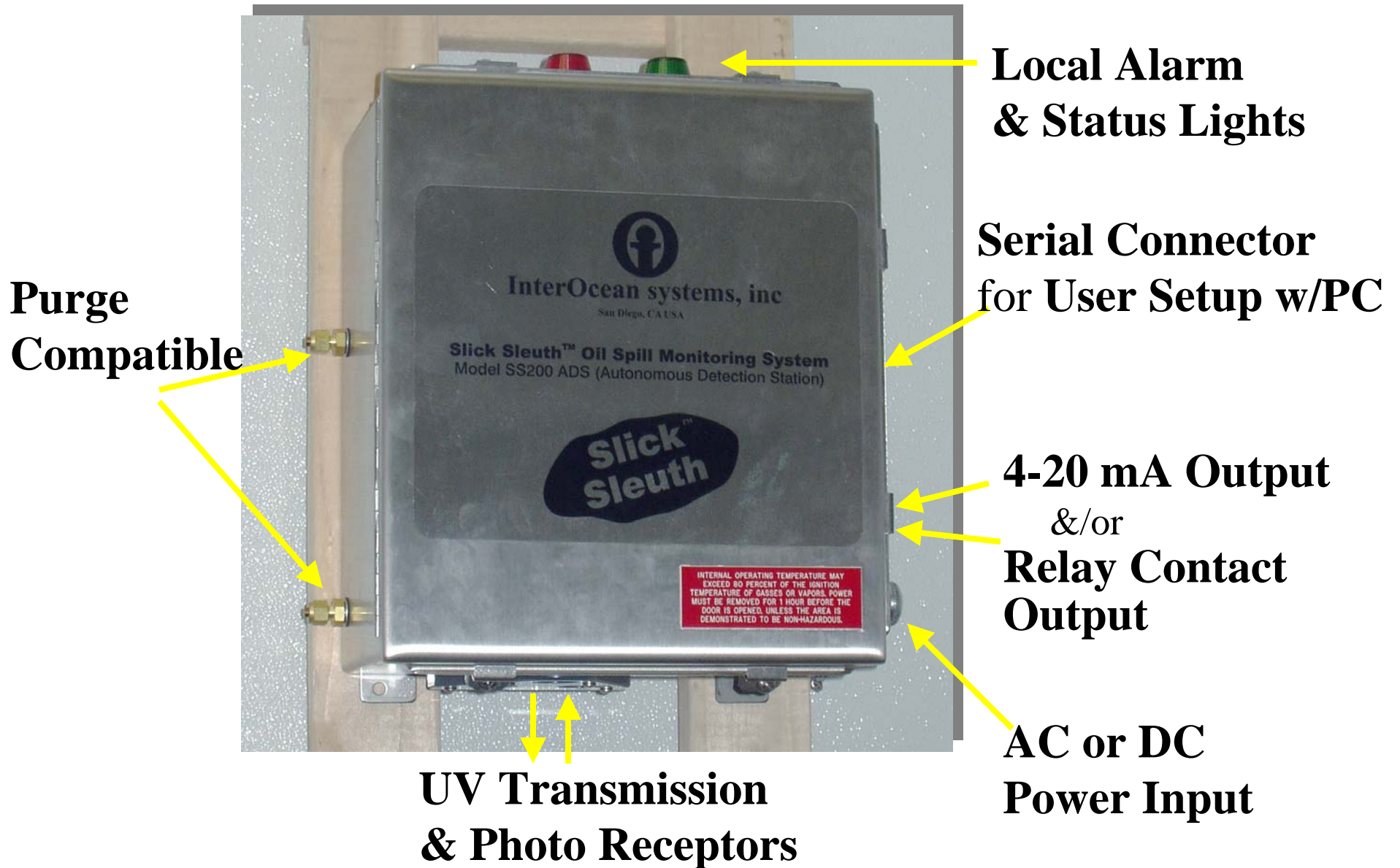

Standard User Interface

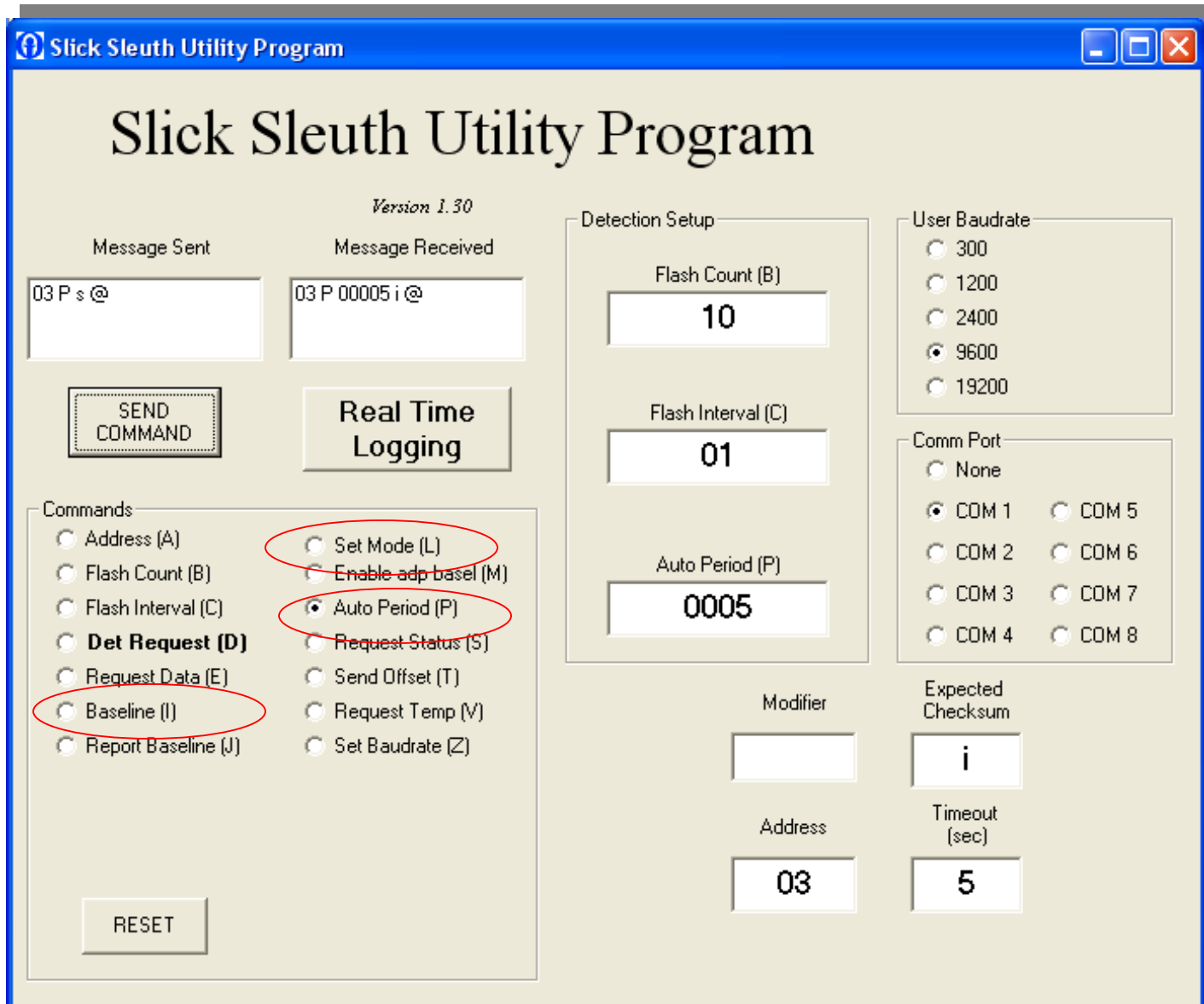

Typical System Configuration



Autonomous Spill Detection Sensor
'Peering' Down Into Deep Pit Sump at GenCo
(photo courtesy of Entergy, Arkansas)

NEMA IP66 Housing

- Weatherproof Stainless Steel Enclosure
- Operable in Hazardous Environments *Optional*

AC Power

- Solar/DC Battery Power *Optional*

Hardwired

- Radio, Cellular, or Satellite Telemetry *Optional*

Analog Output

- Digital (RS232 or RS485) Interface, Plus:
- 4-20mA (for SCADA, PLC, etc)
- Relays (PLC, Actuation of External Valve/Pump)
- Dummy Lights & Alarms
- Real Time Spill Notification via Phone or Pager

Autonomous System

- Network Control/Display Software *Optional*

Application Examples

Power Generators & Distributors

Fossil Fuel-Oil
Hydro-Electric
Nuclear
Remote Substations

Industrial / Manufacturing

Steel & Aluminum
Pulp & Paper
Food Oils & Ethanol

Offshore Industry

Platforms & Rigs
Marine Terminals
Loading/Transfer Buoys



Environmental

Stormwater Monitoring
Inland Waterways
Aquaculture & Fish Farms
Sensitive Wildlife Habitats

Transportation

Ports & Harbors
Marinas & Fuel Docks
Shipyards
Airports
Railways
Military

Oil / Petrochemical

Oil Refineries & Blending Plants
Oil Production Facilities
Pipelines, Storage, & Tank Farms

Water Quality

Wastewater Treatment
Desalination
Intake Protection

Application Examples



Significant Application for Slick Sleuth: Industrial Facilities

- *Spill Alarm
for Early Warning*
- *Prevention & Early
Containment of Spills,
--Prior to Discharge!*
- *Strengthen Regulatory
Compliance
&
Contingency Response
Capabilities*

Application Examples



Autonomous Spill Detection Sensor Station (5 Stations Total)
photo courtesy of Shell Australia

Application Examples

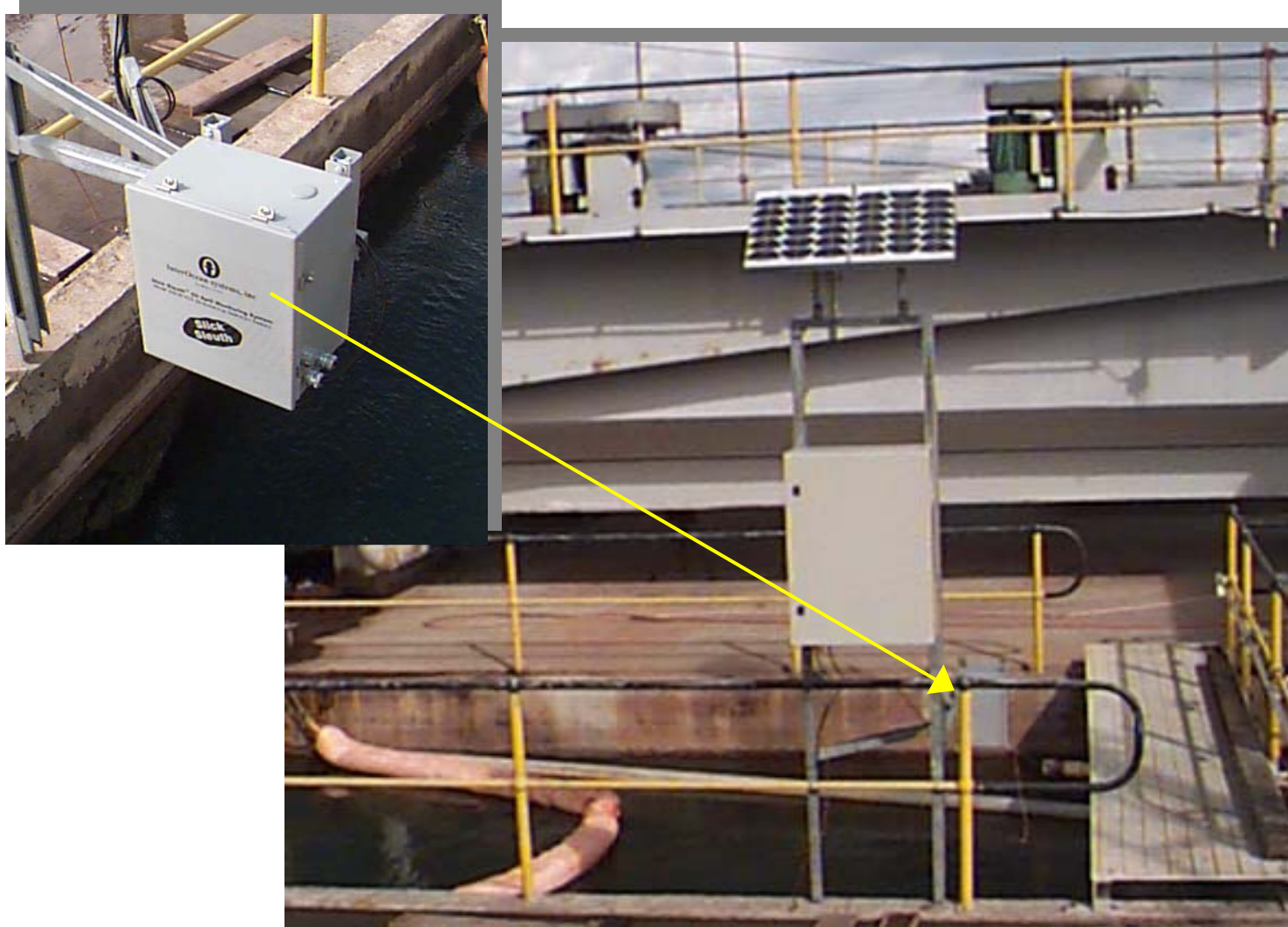

Autonomous Spill Detection Sensor w/DC Power System
photo courtesy of Shell Australia

Application Examples



Spill Monitor Installed Over Separator / Discharge Control Point at Major Power Generation Facility

*photo courtesy of
Delta Electric
Sydney, Australia*

Application Examples



Autonomous Spill Detection Sensor Over Grated Sump
Remote Gas Compressor Station, West Virginia

Application Examples



Autonomous Spill Detection Sensor
w/ Actuator Valve Control & Real Time Alarm to Control Center

Application Examples



*photo courtesy of
Dominion Transmission,
WV, USA*

Automated Real Time Monitor, Alarm & Pump Shutoff

Application Examples



Autonomous Spill Detection Sensor
‘Peering’ Down Into Refinery’s Sewer
(photo courtesy of SK Oil, S. Korea)

Application Examples



*photos courtesy of
Occidental E & P
Amazon Jungle, Ecuador*



**Real Time Monitoring of Outfall Points
at Production Facility in South America**

Application Examples



Remote Networked System

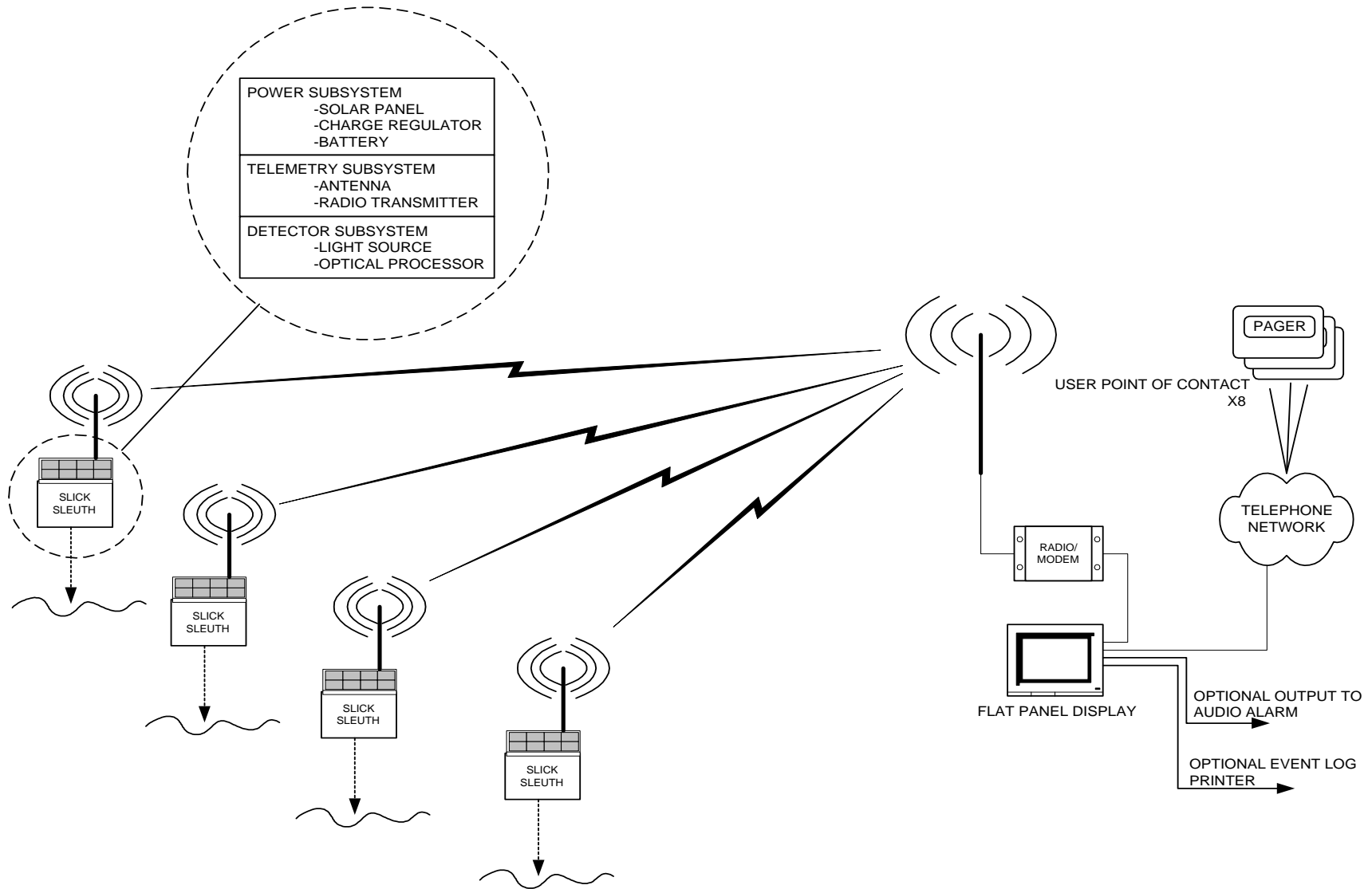

Remote Sensor Array

Networked (Harbor) Sensor

Example

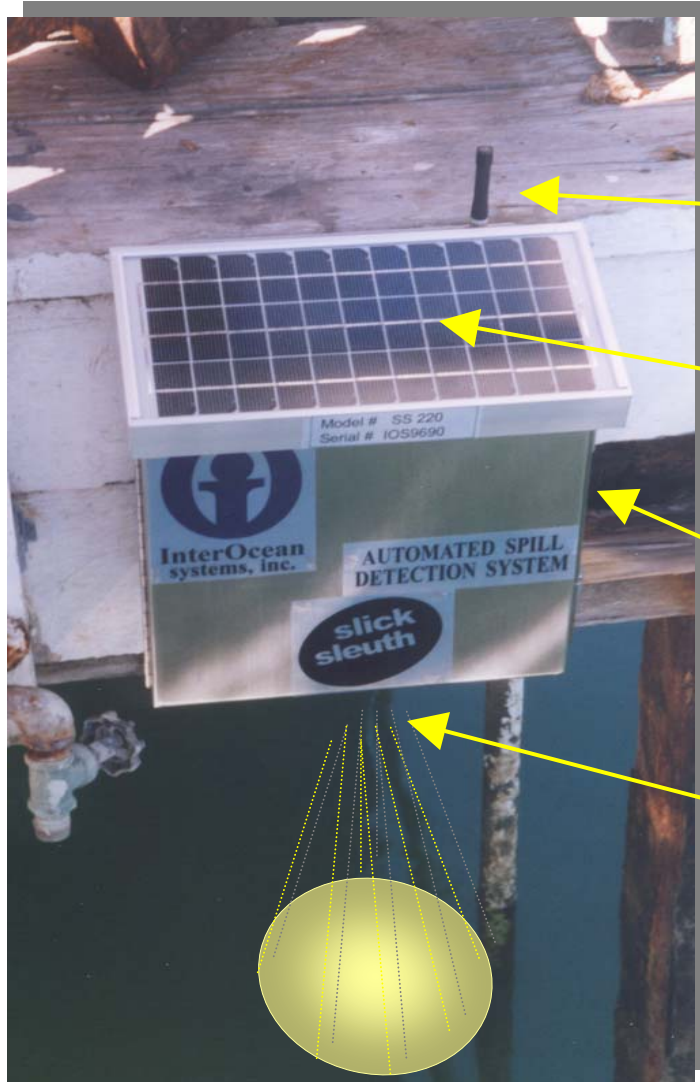

Radio Telemetry

- Un-licensed Spread Spectrum

Self Contained Solar Power

- w/ Internal Rechargeable Batteries

Universal Mounting Bracket

- Install on any Existing Structure
(mounted to pier face in this photo)

Optical Sensor

- 60 sec. Automated Sampling Interval
- 14° Conical Energy Beam
Excites & Scans Target Surface

*Prototype Installation ~ Spring 2005
San Diego Bay*

Remote Networked System

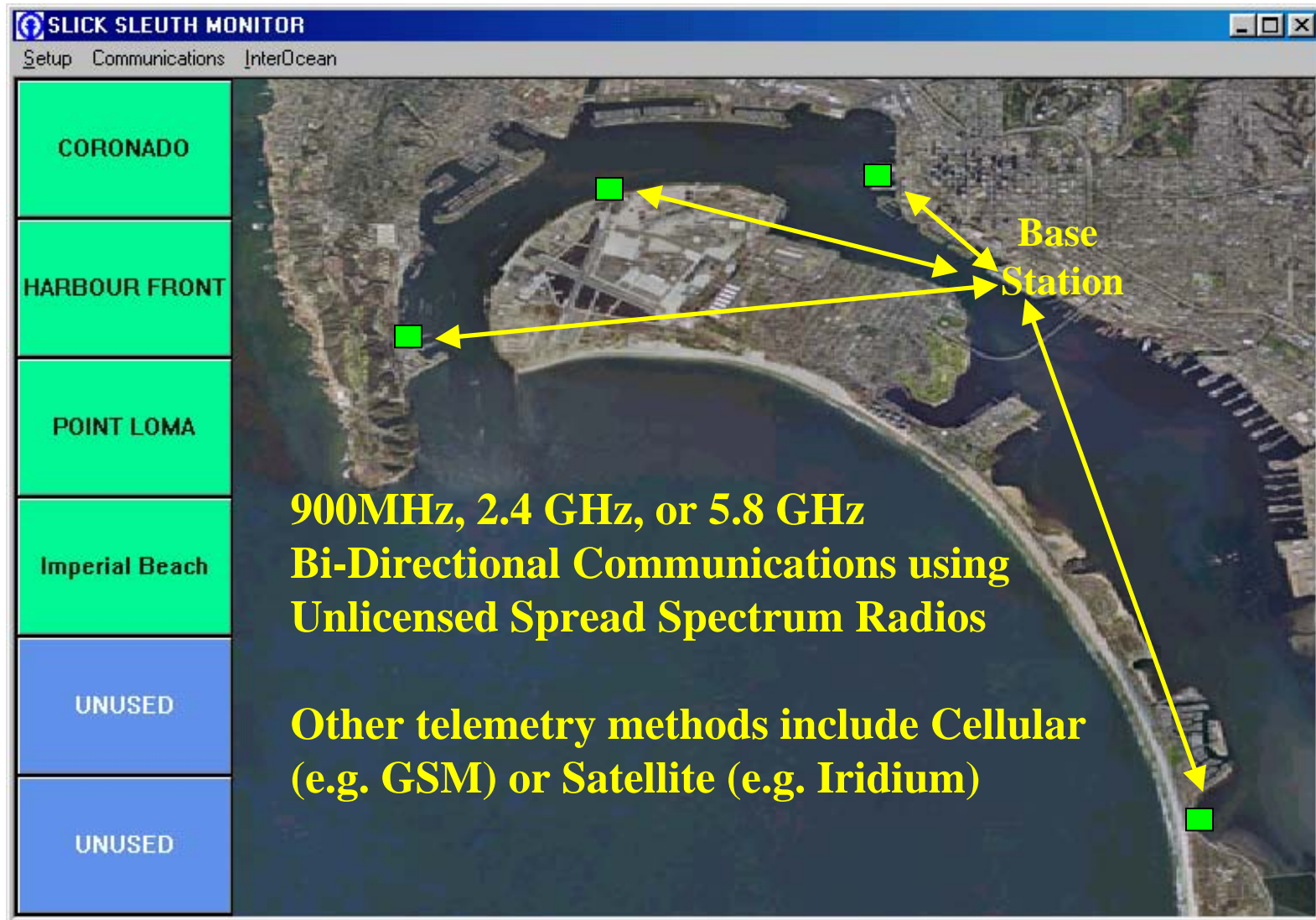

Remote Networked System Display

SLICK SLEUTH MONITOR
 Setup Communications InterOcean

CORONADO

HARBOUR FRONT

POINT LOMA

Imperial Beach

UNUSED

UNUSED

Station Number	Station Location	Position Lat/Long	Detection Status	Today's Date	Time of Sampling	Next Sched Sampling	Actual Reading	Factory Threshold	Baseline Setting	ComLink Status	Sensor Status	Flash Level	Power Status	Station Voltage
1	Coronado	117° 13' 10" 32° 42' 46"	ok	6-May-03	15:20:00	15:30:00	243	1,000	226	ok	ok	100%	ok	12.18v
2	Harbor Front	117° 10' 20" 32° 43' 00"	ok	6-May-03	15:20:02	15:30:02	360	1,000	334	ok	ok	100%	ok	13.19v
3	Pt Loma	117° 14' 25" 32° 41' 41"	DETECTION	6-May-03	15:20:04	15:30:04	15,662	1,000	228	ok	ok	100%	ok	12.90v
4	Imperial Beach	117° 07' 33" 32° 36' 28"	ok	6-May-03	15:20:06	15:30:06	408	1,000	403	ok	ok	100%	ok	13.15v

Slick Sleuth™ Software Monitoring Screen:
 Showing an Oil Spill Detection/Alarm Event (graphically pinpointed in red). The Inset Table Automatically Displays Detailed Real Time Information for Each Remote Station.

Remote Networked System Display

Station Number	Station Location	Position Lat/Long	Detection Status	Today's Date	Time of Sampling	Next Sched Sampling	Actual Reading	Factory Threshold	Baseline Setting	ComLink Status	Sensor Status	Flash Level	Power Status	Station Voltage
1	Coronado	117° 13' 10" 32° 42' 46"	ok	6-May-03	15:20:00	15:30:00	243	1,000	226	ok	ok	100%	ok	12.18v
2	Harbor Front	117° 10' 20" 32° 43' 00"	ok	6-May-03	15:20:02	15:30:02	360	1,000	334	ok	ok	100%	ok	13.19v
3	Pt Loma	117° 14' 25" 32° 41' 41"	DETECTION	6-May-03	15:20:04	15:30:04	15,662	1,000	228	ok	ok	100%	ok	12.90v
4	Imperial Beach	117° 07' 33" 32° 36' 28"	ok	6-May-03	15:20:06	15:30:06	408	1,000	403	ok	ok	100%	ok	13.15v
Open	<i>Unused</i>													
Open	<i>Unused</i>													

Slick Sleuth™ Software Monitoring Grid:

The monitoring grid provides a snapshot of all monitoring stations in the network. By 'pointing and clicking' on any particular station, the user may instantly pull up emergency response information, as well as modify setup parameters, view station history (logged data), etc.

Application Examples

Integrated Monitoring Systems



For Example:

- **Oil Spill Detection & Alarm w/**
- **Mooring Load Monitor**
- **Current Speed & Direction**
- **Directional Wave & Tide**
- **Wind Speed & Direction**
- **Air & Sea Temperature**
- **Video, and Many More**

(...Pending Installation on SBM in Asia)

Application Examples

General Arrangement for Installation of Slick Sleuth Spill Detection Sensor(s) on Offshore Loading Buoys
(SBM CALM Buoy shown here)

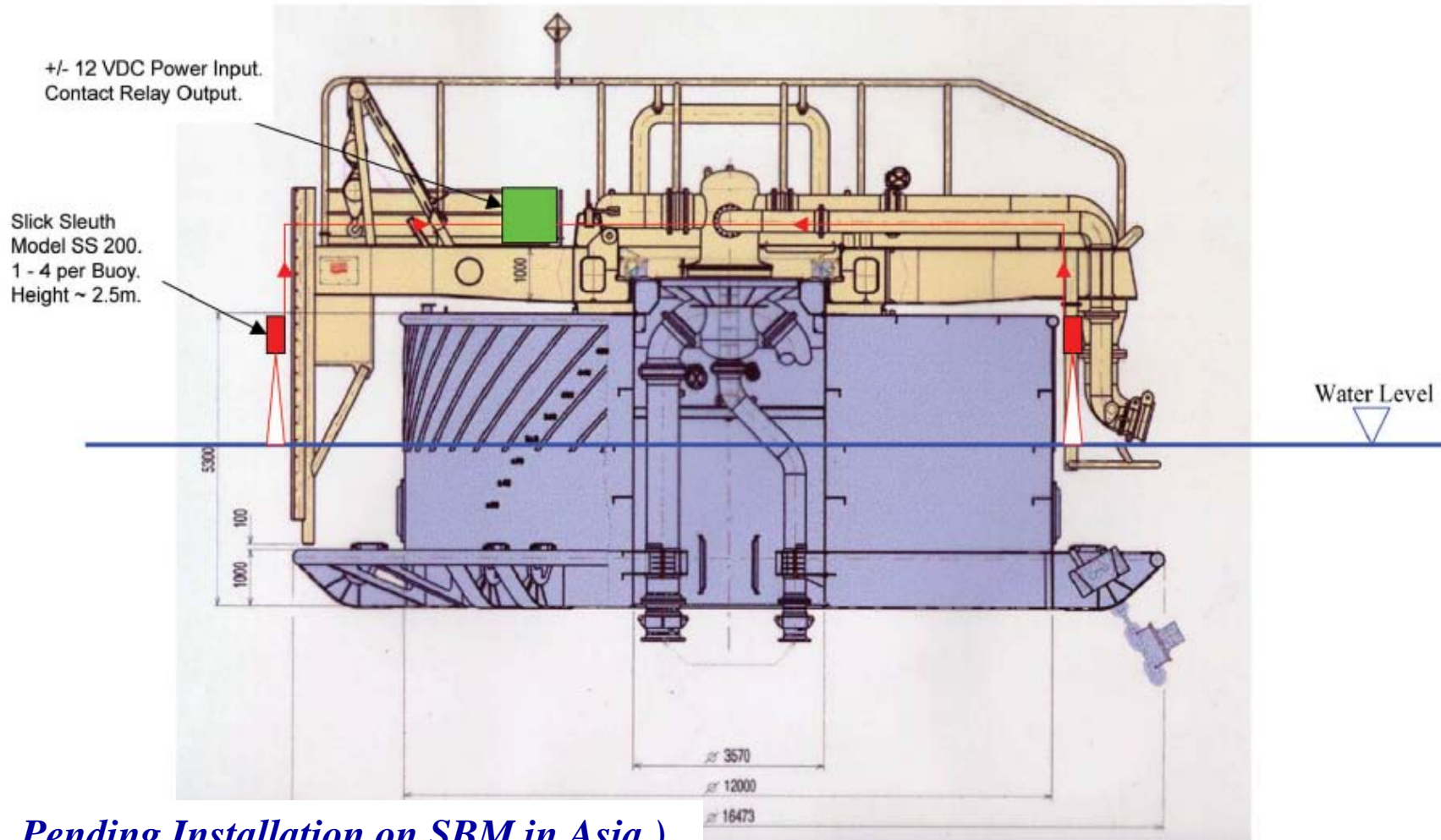

(...Pending Installation on SBM in Asia)

Application Idea!

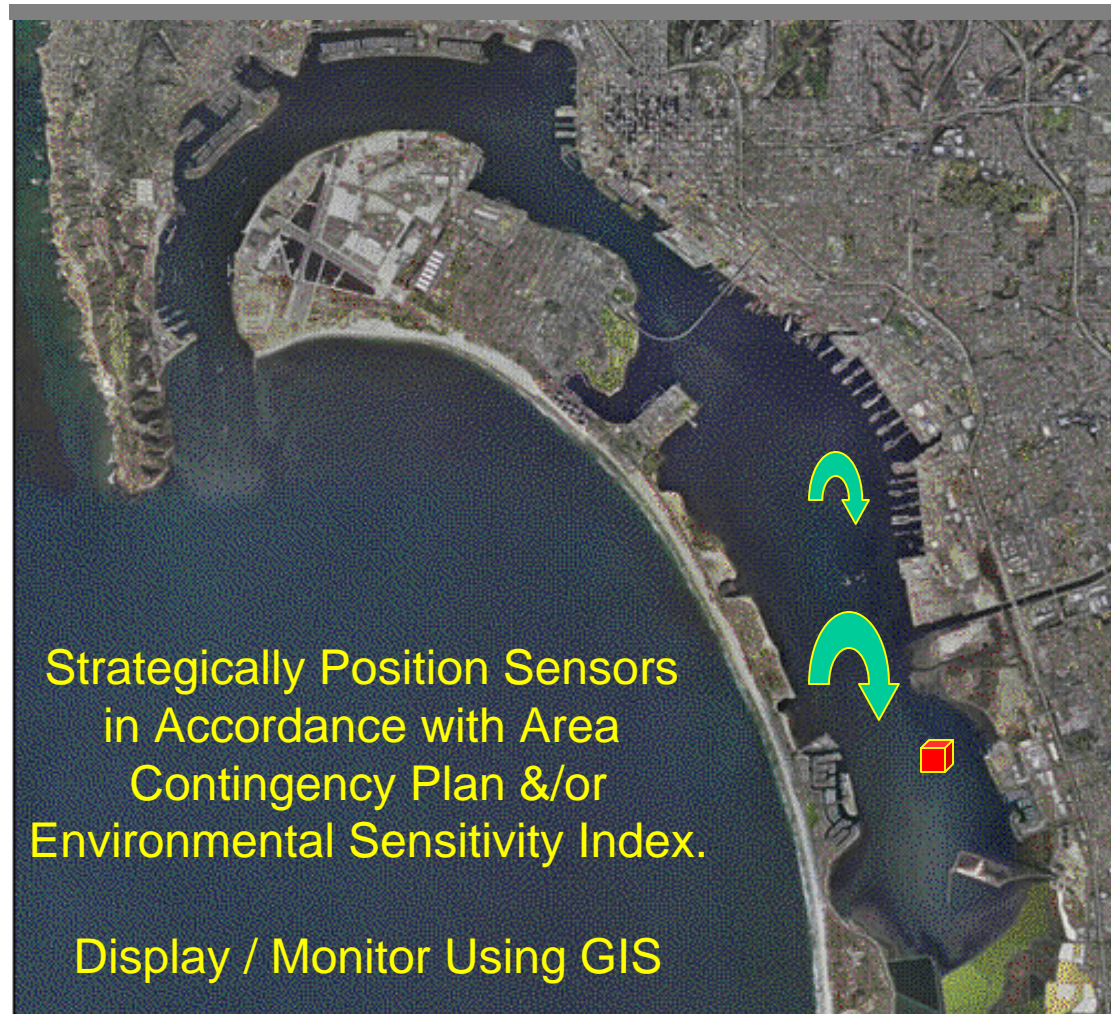

Proposed Application:

Early Warning Protection for Sensitive Eel Grass Habitat, San Diego Bay

Milestones

Succeeded in Proof of Concept, Development, & Commercialization

- System Now Proven and Widely Used !!

Extensive User Installations in a Wide Range of Field Applications

- Shell Oil, Occidental E&P, SK Oil, Dominion Transmission, GS CalTex, Chinese Petroleum Corp, Madison Gas & Electric, Entergy Power, Delta Electric, Buckeye Pipeline, Royal Australian Navy, etc...

Patent Pending

- Process Patent Filed Winter 2005

Certified to EPA Standards

(EPA/530/UST-90/009)

- 3rd Party Certification In Compliance w/ EPA Standards & Guidelines

Testimonial ~ Success Story !!

- *A Spill was Prevented at a Major Refinery when: "Slick Sleuth Signaled an Alarm at the Control Center [Major Refinery]... On-Duty Personnel Hurried to Location and Discovered Spill in Process, Stemming From a Saltwater Heat Exchangers... Immediate Action Was Taken to Contain Spill and Correct Problem... We Were Very Impressed!"*

What's Next?

Increased Awareness

- Introduce New Technology to Regulators, Environmental NGOs, Industrial Facility Managers & HSE Managers
- Especially Domestic Awareness?!

Expanded Range of Field Applications

- Inclusion as Spill Alarm / Monitoring Component of SPCC
- Recognition as a BMP & Best Engineering Practice
- Expanded Use in Inland Waterways and Ports & Harbors
- Use as Remote Early Warning Defense Mechanism to Protect Sensitive Habitats
(Pilot Program?)

Continued Sensor Development

- Increased Range, to Enable Use on Offshore Platforms
- Integration into Explosion-Proof Housing for Class 1 Div 1
- *Ideas & Comments from Regulators and End Users ??*



Utilization of Automated Oil Spill Detection Technology for Clean Water Compliance & Spill Discharge Prevention



QUESTIONS ???

Chris R. Chase
chrisc@interoceansystems.com
+1 858 565 8400