

EPA Cooperative Agreement 832052  
July 1995

# **Life-Cycle Study of Municipal Solid Waste Management System Description**

**Prepared by**

Morton A. Barlaz  
Ranji Ranjithan  
North Carolina State University  
Raleigh, NC 27695

*and*

Keith A. Weitz  
Subba R. Nishtala  
Research Triangle Institute  
Research Triangle Park, NC 27709

## **Notice**

The information contained in this report has been developed as part of ongoing research funded by the U.S. Environmental Protection Agency under Cooperative Agreement No. CR823052 with the Research Triangle Institute. The results from this study are not intended to be used to judge which materials or products are environmentally preferable. Use of the methods or data presented in this report does not constitute endorsement or recommendation for use. This report is subject to review and modification prior to conclusion of the research. Mention of trade names or commercial products does not constitute endorsement or recommendation.

## Abstract

Communities throughout the United States are struggling to develop efficient and cost-effective plans for managing their municipal solid waste (MSW). In the past, waste management systems consisted primarily of waste collection and disposal at a local landfill. Today's MSW management systems often are complex and highly integrated systems that might include materials collection, materials recovery, composting, combustion, and other processing steps. Communities now must make complex decisions involving tradeoffs between environmental performance and cost, which must be carefully analyzed for these integrated systems.

Despite the movement toward integrated systems, many of the existing techniques for analyzing the environmental and economic performance of MSW management systems focus on the individual operations in isolation rather than as a dynamic part of an integrated system. To properly account for all of the environmental effects associated with integrated MSW management systems, planners must have tools that allow them to examine factors outside of the traditional MSW management framework of activities occurring from the point of waste collection to final disposal. This requires an examination of the "upstream" changes in resource use and pollutant generation from raw materials acquisition and manufacturing operations. These upstream changes can be captured by taking a life cycle approach to MSW management.

The U.S. Environmental Protection Agency's (EPA's) Office of Research and Development, Air Pollution Prevention and Control Division, and with cofunding from the U.S. Department of Energy, is working to apply life cycle concepts and tools to the analysis of MSW management systems in the United States. The project began in August of 1994 and is expected to be completed in 1999. The research team for this project includes life cycle assessment (LCA) and MSW experts from Research Triangle Institute (RTI), North Carolina State University, the University of Wisconsin-Madison, Franklin Associates, and Roy F. Weston. In addition, groups of internal advisors and external stakeholders are active participants in this unique forum. The information and tools resulting from this research will help solid waste practitioners identify integrated MSW management strategies that minimize both environmental burdens and cost.

This document describes the overall system that will be used to conduct the life-cycle and cost analysis of integrated MSW management alternatives. The system is divided into a number of distinct solid waste management processes including waste generation, source reduction, collection and transfer, materials recovery, composting, combustion, refuse-derived fuel production and combustion, anaerobic digestion, and burial. The system also includes processes involved with manufacturing products from virgin material and remanufacturing products from recycled materials.

## Table of Contents

Notice .....	ii
Abstract .....	iii
List of Figures .....	v
List of Tables .....	vi
Abbreviations and Symbols.....	vii
Section 1     Introduction .....	1
Section 2     Waste Generation.....	5
Section 3     Waste Composition .....	5
Section 4     In-Home Recyclables Separation .....	7
Section 5     Waste Collection .....	7
5.1     Collection of Residential Refuse and Recyclables .....	8
5.2     Collection of Multi-Family Dwelling Refuse and Recyclables .....	9
5.3     Collection of Commercial Waste.....	10
Section 6     Transfer Stations .....	10
Section 7     Material Recovery Facilities .....	16
Section 8     Remanufacturing and Energy Recovery .....	19
Section 9     Composting.....	22
Section 10    Waste-to-Energy Combustion .....	23
Section 11    Refuse Derived Fuel and Co-Combustion .....	23
Section 12    Anaerobic Digestion.....	24
Section 13    Landfills.....	24
Section 14    Source Reduction.....	25
Section 15    Summary of System Boundaries .....	26
15.1    System Boundaries for LCI.....	26
15.2    System Boundaries for Cost Analysis.....	27
References .....	28

## List of Figures

Figures		Page
1	Functional Elements of the Life Cycle Analysis of Municipal Solid Waste Management Alternatives.....	2
2	Alternatives for Solid Waste Management.....	3
3	Waste Flow Alternatives for Residential Newsprint.....	4
4a	Alternate Roles of a Transfer Station in Mixed Refuse Collection.....	12
4b	Collection of Presorted Recyclables .....	12
4c	Collection of Commingled Recyclables .....	13
4d	Co-Collection in a Single Compartment Vehicle.....	13
4e	Co-Collection in a Double Compartment Vehicle.....	14
4f	Collection of Residential Mixed Waste.....	14
4g	Transport of Recyclables from a Drop-Off Station .....	15
4h	Role of Rail Transfer Stations .....	15
5	Illustration of the Framework for Calculation of Life Cycle Effects Including Remanufacturing for Recycled Newsprint .....	21

## **List of Tables**

Table		Page
1	Components of MSW to Be Considered in the System.....	6
2	Materials Which Can Be Recycled at Each MRF Type .....	18

## Abbreviations and Symbols

BTU	British Thermal Unit
EPA	United States Environmental Protection Agency
FAL	Franklin Associates, Limited
KWH	Kilowatt Hour
LCA	Life-Cycle Assessment
LCI	Life-Cycle Inventory
MRF	Materials Recovery Facility
MSW	Municipal Solid Waste
NCSU	North Carolina State University
POTW	Publicly Owned Treatment Works
RCRA	Resource Conservation and Recovery Act
RTI	Research Triangle Institute
SETAC	Society for Environmental Toxicology and Chemistry

## 1. INTRODUCTION

The objective of this document is to describe the system and the system boundaries which will be used to conduct the life-cycle inventory (LCI) and cost analysis of municipal solid waste (MSW) management alternatives. This system description is a small but critical part of the overall project.

The overall system will be divided into a number of distinct solid waste management processes linked together as illustrated in Figure 1. These processes include waste generation, source reduction, collection and transfer, separation (materials recovery and drop-off facilities), treatment (which may include composting, combustion or RDF production) and burial. Remanufacturing is considered to the extent that a specific component of the waste stream is recycled. In this case, the LCI will include energy and resource consumption and the environmental releases involved in the remanufacturing process, as well as the energy, resources, or releases offset by virtue of using recycled versus virgin materials.

Although Figure 1 illustrates the functional elements which comprise the MSW system, the key unit operations in the system and the manner in which waste can flow between these unit operations are illustrated in Figure 2. As presented in Figure 2, there is a lot of interrelatedness between the individual unit operations. For example, decisions made with respect to waste separation influence downstream processes such as combustion. An example of waste management alternatives for one waste component is presented in Figure 3. This figure illustrates the possible paths for old newsprint (ONP) through the system.

In defining the solid waste management system, our objective is to be as flexible as possible. However, given the large diversity of settings in which MSW is generated in the United States, development of a single system definition to address all situations will be unnecessarily complicated. Thus, there are likely to be situations where this system definition cannot be applied.

The ultimate products of this research will include a database and decision support tool that will enable users to perform an LCI and cost analyses based on locality specific data on MSW generation and management. The decision support tool will be supported by the database, which will contain data on LCI parameters for individual solid waste management unit operations. Work will proceed concurrently to collect the data required for analysis of site specific solid waste management scenarios and to develop the decision support system.

This document is structured to follow the order of the functional elements as presented in Figure 1, with the exception of source reduction which is presented after landfills. The discussion of system boundaries is summarized in the final section by which time the reader will have a more complete understanding of the proposed system.



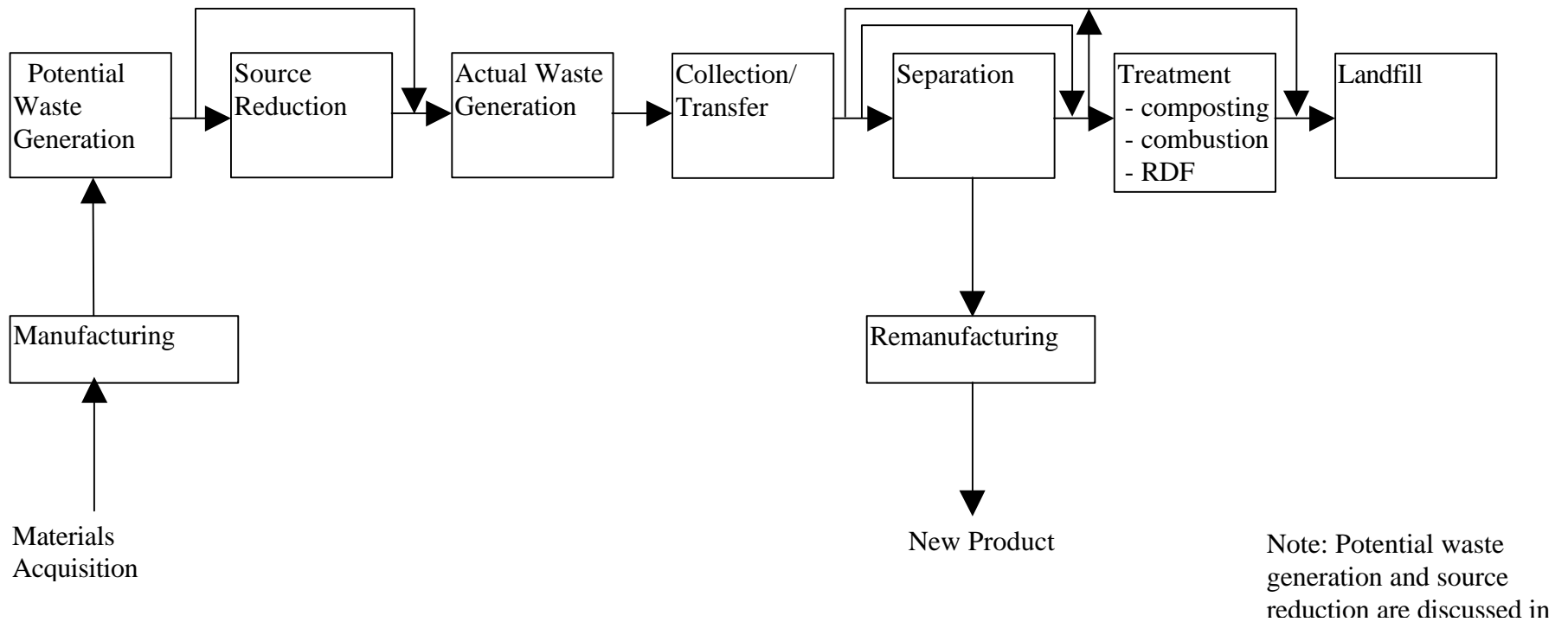

Figure -1 Functional Elements of the Life Cycle Analysis of Municipal Solid Waste Management Alternatives.

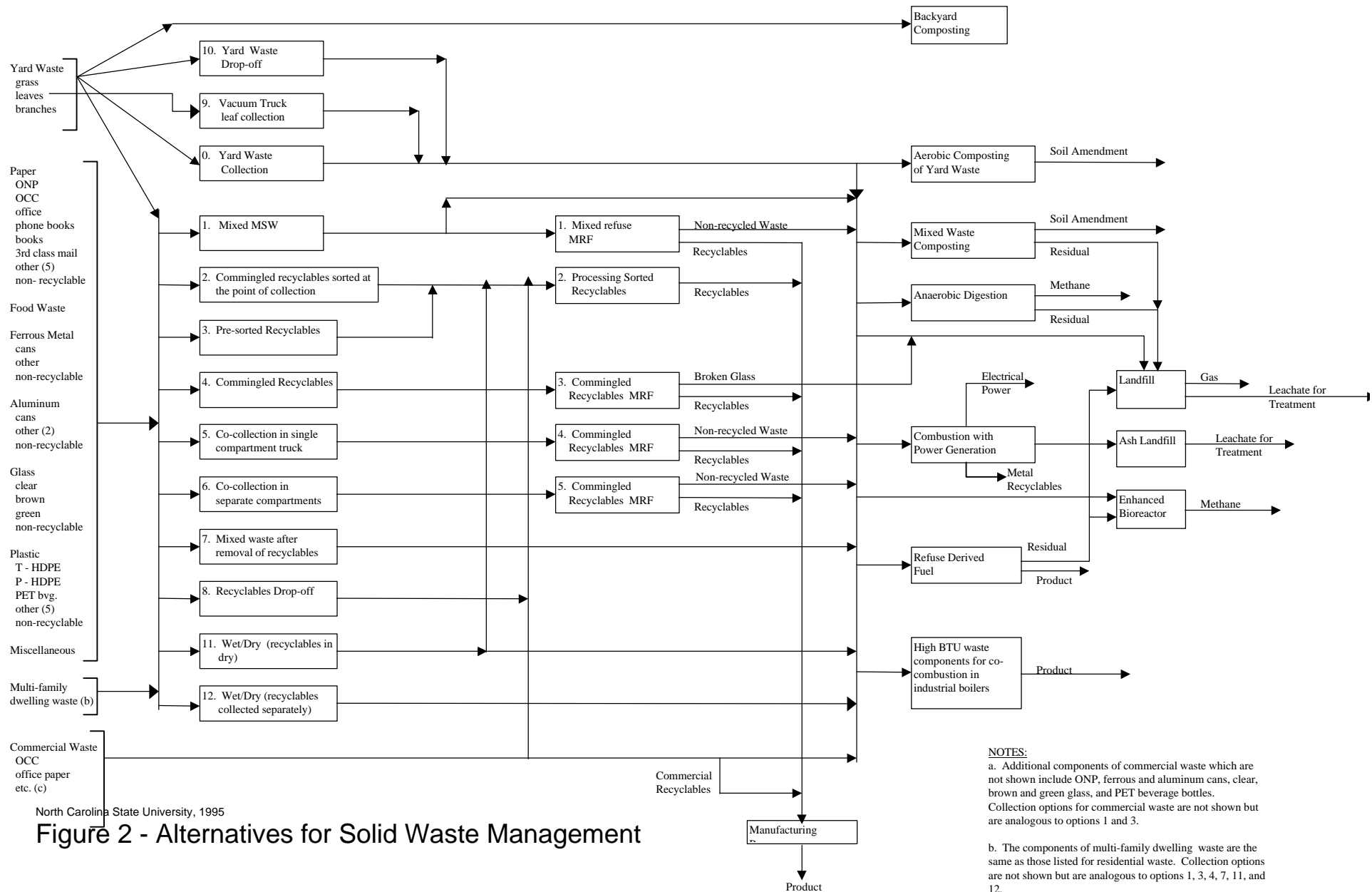

Figure 2 - Alternatives for Solid Waste Management

- NOTES:**
- Additional components of commercial waste which are not shown include ONP, ferrous and aluminum cans, clear, brown and green glass, and PET beverage bottles. Collection options for commercial waste are not shown but are analogous to options 1 and 3.
  - The components of multi-family dwelling waste are the same as those listed for residential waste. Collection options are not shown but are analogous to options 1, 3, 4, 7, 11, and 12.
  - The components of commercial waste are: office paper, old corrugated containers, Phone Books, Third Class Mail, ferrous cans, aluminum cans, clear glass, brown glass, green glass, PET beverage bottles, newspaper, other recyclable (3), non-recyclables (3).
  - Transfer stations (truck and rail) are not shown due to space limitations. They are included in the system of alternatives.

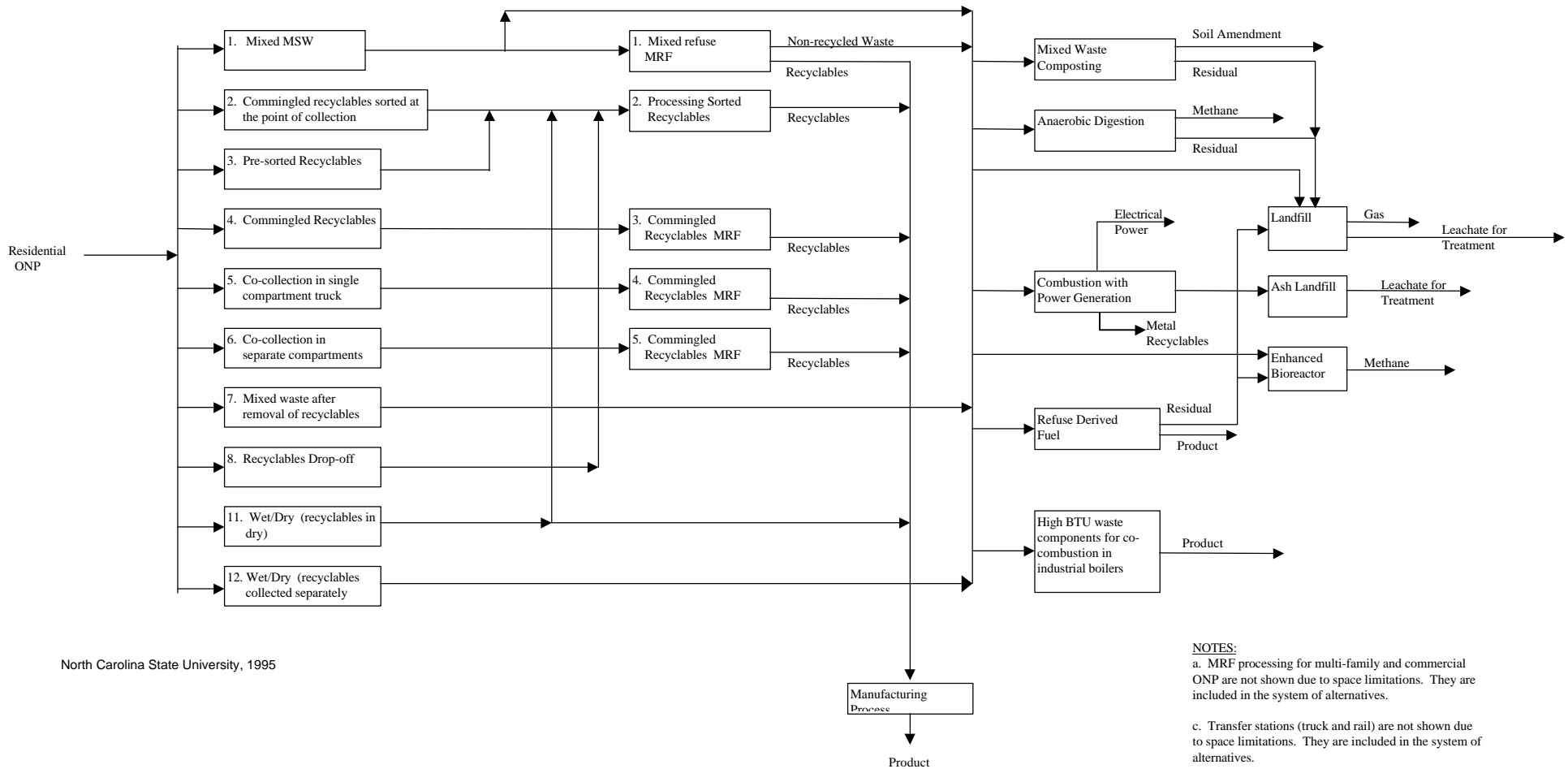

Figure 3 - Waste Flow Alternatives for Residential Newspaper

## **2. WASTE GENERATION**

The system for this project includes wastes defined as MSW by the U.S. Environmental Protection Agency (EPA) in their waste characterization studies (see EPA, 1994). This definition includes waste generated in the residential, commercial, institutional and industrial sectors but excludes industrial process waste, sludge, construction and demolition waste, pathological waste, agricultural waste, mining waste and hazardous waste. Ash generated from the combustion of MSW will be included in the system.

The MSW stream has been divided into three waste categories: residential, multifamily dwelling, and commercial. The logic for this separation is that different collection and recycling alternatives apply to each category. The third category of waste defined here is commercial waste which includes MSW generated in offices, institutions, industries, etc. Arrangements for the collection of this waste are typically handled by the waste generator and are unlikely to overlap with the collection of residential and multifamily dwelling waste. However, these wastes typically enter the same system that handles residential and multifamily dwelling waste at some point in their management.

The composition of waste from the residential, multifamily and commercial sectors will likely differ. In developing the LCI, the user will have the opportunity to input the waste generation rate and composition for each of the waste generation sectors. Default data will be provided for each category. We recognize that such data may be difficult for the user to obtain for commercial waste. However, the composition and generation rate for commercial waste is extremely site specific and default data are not likely to be reliable. Ideally, commercial waste generation factors could be provided by SIC code. Development of such factors is beyond the scope of this project. Should such factors be developed by others, the commercial waste component of the LCI could be modified to incorporate SIC codes.

## **3. WASTE COMPOSITION**

MSW has been divided into individual components as listed in Table 1. The rationale for the selected components is described here. The residential and multifamily dwelling waste streams have been divided into 28 components. The components were selected to include those items which are most commonly recycled such as old newsprint (ONP) and HDPE milk and water containers. In addition, the categories have been selected to allow for flexibility by the addition of "other" categories. For example, two extra categories are allowed for "other paper." If the user wishes to consider the recycling of a paper component(s) not listed in Table 1, then the composition of that waste component can be accounted for in a "paper-other" category. Similarly, if the user does not wish to consider recycling of a component, such as office paper from residential waste, then the user simply enters its composition as 0%. Two "other" categories have been added for plastics, paper and aluminum and a single "other" category was added for ferrous metal in the residential and multifamily dwelling waste streams.

**TABLE 1. COMPONENTS OF MSW TO BE CONSIDERED IN THE SYSTEM**

<b>Residential Waste</b>	<b>Multifamily Dwelling Waste</b>	<b>Commercial Waste</b>
<b>Yard Waste</b>	<b>Yard Waste</b>	1. office paper
1. grass <sup>a</sup>	1. grass <sup>a</sup>	2. old corrugated containers
2. leaves <sup>a</sup>	2. leaves <sup>a</sup>	3. phone books
3. branches <sup>a</sup>	3. branches <sup>a</sup>	4. third class mail
4. Food Waste	4. Food Waste	5. aluminum cans
<b>Ferrous Metal</b>	<b>Ferrous Metal</b>	6. clear glass
5. cans	5. cans	7. brown glass
6. other ferrous metal	6. other ferrous metal	8. green glass
7. non-recyclables	7. non-recyclables	9. PET beverage bottles
<b>Aluminum</b>	<b>Aluminum</b>	10. newspaper
8. cans	8. cans	11-12. other recyclables
9-10. other - aluminum	9-10. other – aluminum	13-15. other non-recyclables
11. non-recyclables	11. non-recyclables	
<b>Glass</b>	<b>Glass</b>	
12. clear	12. clear	
13. brown	13. brown	
14. green	14. green	
15. non-recyclable	15. non-recyclable	
<b>Plastic</b>	<b>Plastic</b>	
16. translucent-HDPE	16. translucent-HDPE	
17. pigmented-HDPE bottles	17. pigmented-HDPE bottles	
18. PET beverage bottles	18. PET beverage bottles	
19-24. other plastic	19-24. other plastic	
25. non-recyclable plastic	25. non-recyclable plastic	
<b>Paper</b>	<b>Paper</b>	
26. newspaper	26. newspaper	
27. office paper	27. office paper	
28. corrugated containers	28. corrugated containers	
29. phone books	29. phone books	
30. books	30. books	
31. magazines	31. magazines	
32. third class mail	32. third class mail	
33-37. other paper	33-37. other paper	
38. paper - non-recyclable	38. paper - non-recyclable	
39. miscellaneous	39. miscellaneous	

<sup>a</sup>Yearly average compositions are required.

The waste components listed in Table 1 are the same for residential and multifamily dwelling waste. However, different compositions for each waste component may be used if desired. The commercial waste stream has been divided into twelve components. These components include the major recyclables in commercial waste based on national averages (office paper and old corrugated containers (OCC)), materials which are commonly recycled (aluminum cans, PET beverage bottles, container glass and newsprint), two “other” categories and non-recyclables.

Although wastes are listed as individual components in Table 1, there are cases where wastes can be grouped together. The system is mathematically defined to allow consideration of mixed color glass recycling in addition to recycling by individual color. Of course, recycling of mixed color glass would be dependent on the availability of a market. The user will have the opportunity to input the revenue associated with mixed color glass, as well as the opportunity to remove from consideration mixed color glass recycling. Similarly, the user will have the opportunity to allow consideration of mixed paper or mixed plastic recycling. In the case of mixed paper and mixed plastic, the user will be required to specify whether the recyclables are used in remanufacturing or as a fuel.

For waste generation, the user can input generation and composition data, as described in this and the previous section. Default data on physical and chemical characteristics of each waste component such as density, BTU value, and moisture content will be provided. These data will be used to calculate characteristics of the waste stream, such as moisture content and BTU value, as a function of waste composition.

#### **4. IN-HOME RECYCLABLES SEPARATION**

The manner in which residential and multifamily dwelling waste are collected will influence resource consumption (e. g. water, electricity) in the home (or apartment). Several of the collection alternatives described in the following section include source separation of recyclables. Where a collection alternative involves the separate setout of recyclables, they may be rinsed for in-home storage prior to setout at curbside. Specifically, if recyclables are collected in options 2 through 6 described in the following section, then ferrous cans, aluminum cans, glass bottles, t-HDPE and PET beverage bottles may be rinsed.

#### **5. WASTE COLLECTION**

There are a number of options for the collection of refuse generated in the residential, multifamily dwelling and commercial sectors. The manner in which refuse is collected will affect the cost, resource utilization, releases and design of both the collection operation and potential down stream processing facilities such as a materials recovery facility (MRF). The collection options which we propose to consider are presented in this section. The numbers given for each option are used throughout this document and appear in Figure 2. Alternatives for the collection of multifamily dwelling and commercial refuse are not individually presented in Figure 2 due to space

limitations. The role of transfer stations is described in the following sections.

## **5.1 Collection of Residential Refuse and Recyclables**

### Mixed Refuse Collection

1. Collection of mixed refuse in a single compartment truck with no separation of recyclables.

### Recyclables Collection

2. Set out of commingled recyclables which are sorted by the collection vehicle crew at the point of collection into a multi-compartment vehicle.
3. Collection of recyclables presorted by the generator into a multi-compartment vehicle.
4. Collection of commingled recyclables in a vehicle with two compartments; one for all paper components, and the other for non-paper recyclables.

### Co-Collection

5. Collection of mixed refuse and recyclables in different colored bags for transport in a single compartment of a vehicle. Bags would then be sorted at a MRF. All paper recyclables are collected in one bag, and non-paper recyclables are collected in a separate bag.
6. Collection of mixed refuse and recyclables in different colored bags in separate compartments of the same vehicle. The refuse and recyclables would then be delivered to a MRF and the mixed refuse would be delivered to a combustion facility, composting facility, RDF plant or landfill. Commingled recyclables and mixed waste are collected in a three compartment truck - one compartment for mixed waste, one for paper recyclables, and the third compartment for non-paper recyclables.

### Residuals Collection

7. If recyclables are collected in options 2, 3 or 4, then residual MSW is collected in a single compartment vehicle as in option 1.

### Recyclables Drop-Off

8. This alternative allows for the waste generator to bring recyclables to a centralized drop-off facility. This could also be a buy-back center.

#### Yard Waste Collection

0. Collection of yard waste in a single compartment vehicle. The user will be asked to specify whether waste is collected in bulk, in plastic bags which must be emptied prior to composting, or in biodegradable paper bags which need not be emptied. Of course, yard waste may also be collected as mixed refuse in options 1 or 7 unless a yard waste ban is specified by the user.
9. Dedicated collection of leaves in a vacuum truck.
10. This alternative allows for the waste generator to bring yard waste to a centralized composting facility.

#### Wet/Dry Collection

11. Wet/Dry collection with recyclables included with the dry portion. The user will be asked to specify whether various paper types are to be included in the wet or dry collection compartments.
12. Wet/Dry collection with recyclables collected in a separate vehicle. The user will be asked to specify whether various paper types are to be included in the wet or dry collection compartments.

## **5.2 Collection of Multifamily Dwellings Refuse and Recyclables**

#### Mixed Refuse Collection

13. Collection of mixed refuse from multifamily dwellings in a single compartment truck. The user will be required to specify the use of hauled or stationary containers.

#### Recyclables Collection

14. Collection of pre-sorted recyclables into multiple stationary or hauled containers.
15. Collection of commingled recyclables in a single bin for non-paper recyclables and a second bin for paper recyclables.

#### Residuals Collection



16. If recyclables are collected in options 12 or 13, then residual MSW is collected in a single compartment vehicle as in option 11.

#### Wet/Dry Collection

17. Wet/Dry collection with recyclables included with the dry portion. The user will be asked to specify whether various paper types are to be included in the wet or dry collection compartments.
18. Wet/Dry collection with recyclables collected in a separate vehicle. The user will be asked to specify whether various paper types are to be included in the wet or dry collection compartments.

### **5.3 Collection of Commercial Waste**

#### Recyclables Collection

19. Collection of presorted recyclables.

#### Mixed Refuse Collection

20. Collection of mixed refuse before or after recycling.

Multifamily dwelling waste may or may not be collected by the city in a manner similar to residential refuse collection. Whether this waste is collected by the city or a private contractor should not affect the LCI. The user will be asked to specify whether multifamily dwelling waste is collected by the city. If yes, then this waste will be analyzed as part of the collection unit operation. If no, then this waste will be collected by a private contractor and the user will be asked to specify which, if any, components of MSW are recycled. Whether multifamily dwelling waste is collected by the city or the private sector, its life-cycle implications and costs will be included in the system.

## **6. TRANSFER STATIONS**

Once refuse has been collected, there are a number of facilities to which it may be transported including a transfer station, MRF, a combustion facility, RDF plant, composting facility or a landfill. Prior to describing the manner in which each of these processes is handled, the potential role of transfer stations is described.

The potential role of transfer stations is illustrated in Figures 4a to 4g. In Figure 4a, it is assumed that refuse is collected as mixed refuse (collection option 1). The waste may be transported to a transfer station, mixed refuse MRF, combustion facility, RDF plant, composting facility or a

landfill. If the waste is brought to a transfer station, then the waste could subsequently be brought to any of these facilities. Waste flow down stream of a MRF, combustion facility, RDF plant or composting facility plant is not illustrated in Figure 4 for simplicity. These flows are part of the system and are illustrated in Figure 2. A transfer station handling mixed refuse will be referred to as Transfer Station 1. Different transfer station designs will be required dependent upon the type of waste processed.

Figure 4b illustrates collection of presorted recyclables in collection options 2 and 3. In these cases, recyclables could be transported either directly to a MRF designed to process presorted recyclables or to a transfer station followed by a MRF.

Figure 4c illustrates the collection of commingled recyclables. These recyclables may be transported to either a transfer station (Transfer Station 3) or directly to a MRF designed to process commingled recyclables (MRF 3).

Figure 4d illustrates the role of a transfer station where refuse and recyclables are co-collected in a single compartment vehicle (collection option 5). In this case, refuse and recyclables could be delivered to either a MRF or to a transfer station. If the refuse and recyclables are delivered to a MRF, then the MRF also functions as a transfer station because the refuse must be removed from the facility to either a combustion facility, RDF plant, composting facility or a landfill. Alternately, the refuse could be delivered to a transfer station for separation of the refuse and commingled recyclables.

Figure 4e illustrates the role of a transfer station in which refuse and recyclables are co-collected in a three compartment vehicle (collection option 6). Commingled recyclables and refuse may be transported to a transfer station where the recyclables and refuse are separated and transported to regional waste management facilities. In this case, the refuse would then be transported to a combustion facility, composting facility, RDF plant or landfill and the recyclables would be transported to a MRF designed to process commingled recyclables (MRF-3). This transfer station is identified as Transfer Station 4. Alternately, the commingled recyclables and refuse may be transported to MRF-5 where the recyclables are processed and the refuse is transported to a combustion facility, RDF plant, composting facility or landfill.

The alternative roles of transfer stations in the collection of residual MSW assuming separate collection of recyclables (collection option 7) are illustrated in Figure 4f. In this collection option, recycling has already occurred. Thus, the MSW is transported to a combustion facility, RDF plant, composting facility or landfill either through or around a transfer station.

Figure 4a - Alternate Roles of a Transfer Station in Mixed Refuse Collection (Collection Option 1)

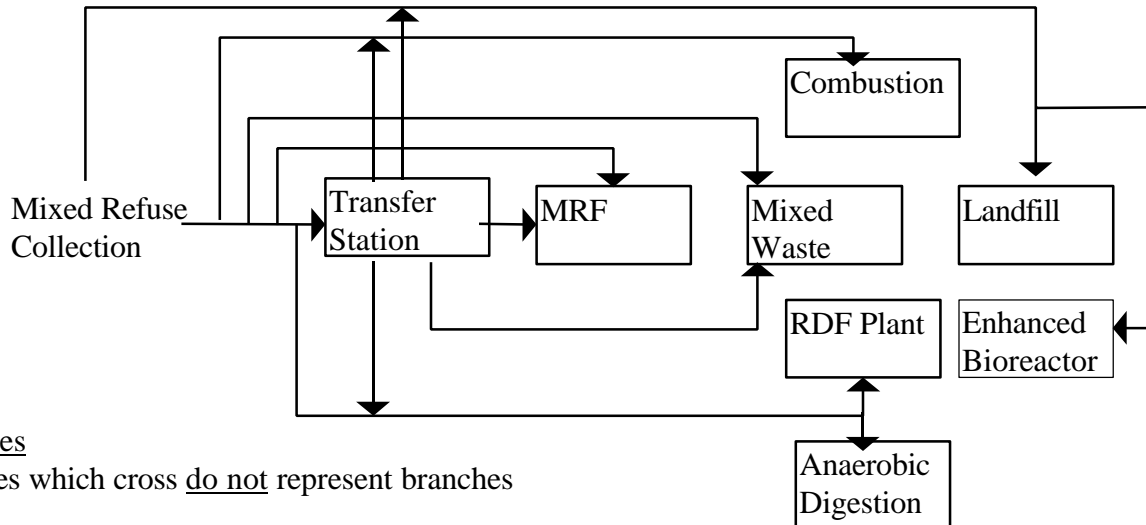

Notes

Lines which cross do not represent branches

Waste transport downstream of MRF's, combustion facilities, composting and RDF plants is not shown for simplicity. These flows are considered in the system.

Figure 4b - Collection of Commingled Recyclables (Collection Option 4)

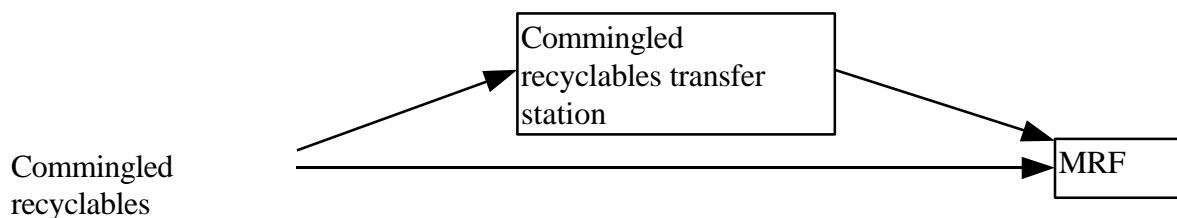

Note

Recyclables transport downstream of a MRF is not illustrated for simplicity. Transport of recyclables to a manufacturing facility is part of the system.

Figure 4c - Co-Collection in a Single Compartment Vehicle  
(Collection Option 5)

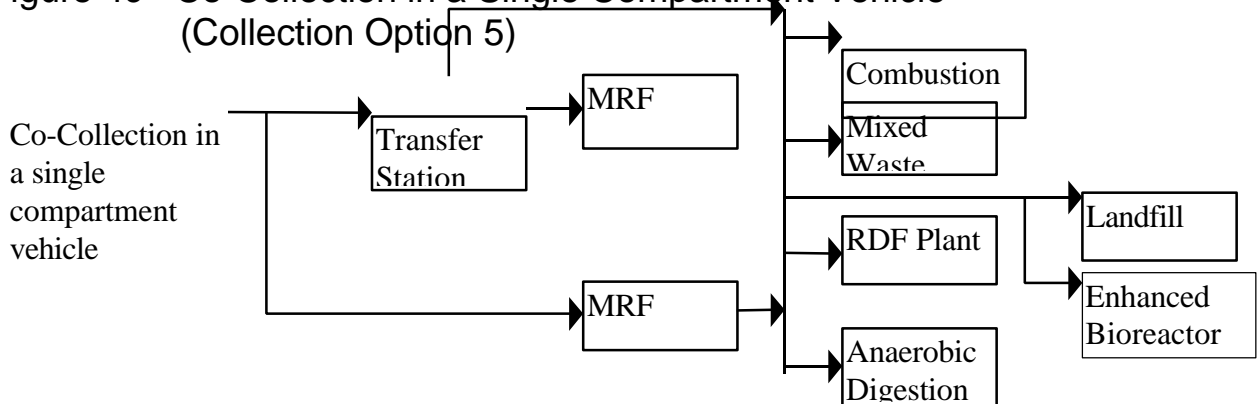

Note

Waste transport downstream of MRFs, combustion facilities, composting and RDF plants is not shown for simplicity. These flows are considered in the system.

Figure 4d - Co-Collection in a Three Compartment Vehicle  
(Collection Option 6)

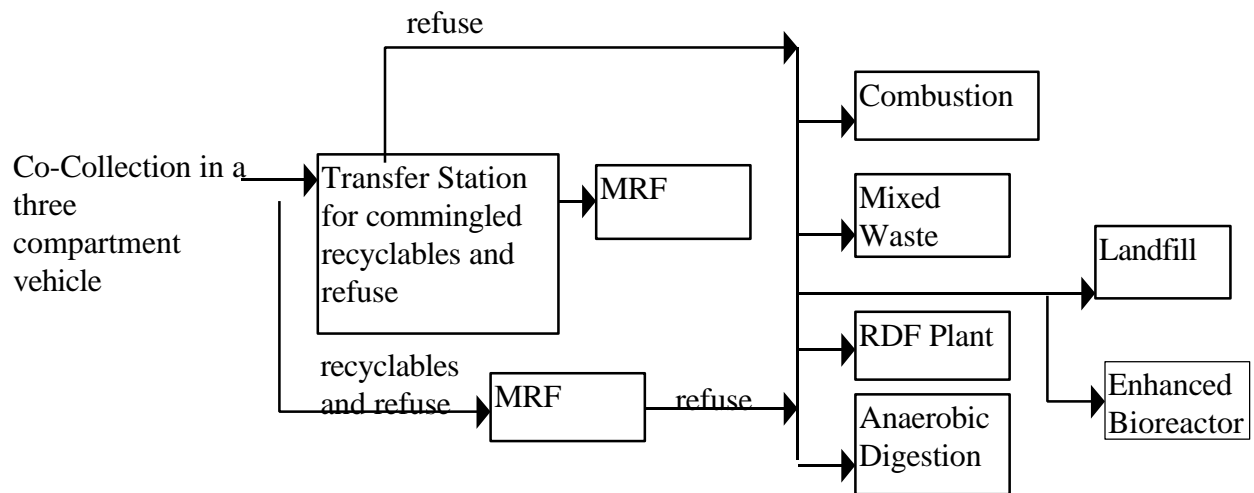

Note

Recyclables transport downstream of a MRF is not illustrated for simplicity. Transport of recyclables to a manufacturing facility is part of the system.

Figure 4e - Collection of Pre-sorted recyclables (Collection Options 2 and 3)

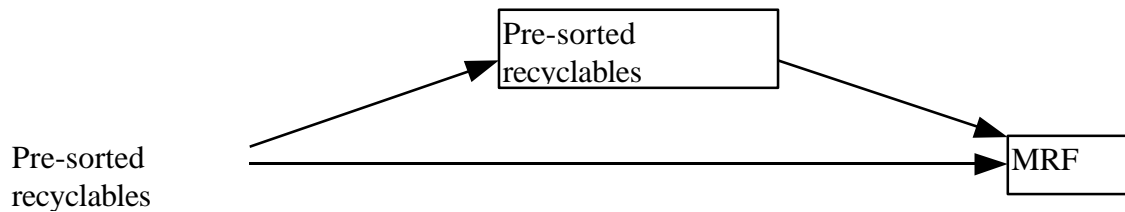

Note

Recyclables transport downstream of a MRF is not illustrated for simplicity. Transport of recyclables to a manufacturing facility is part of the system.

Figure 4f - Collection of Residential mixed waste (Collection Option 7)

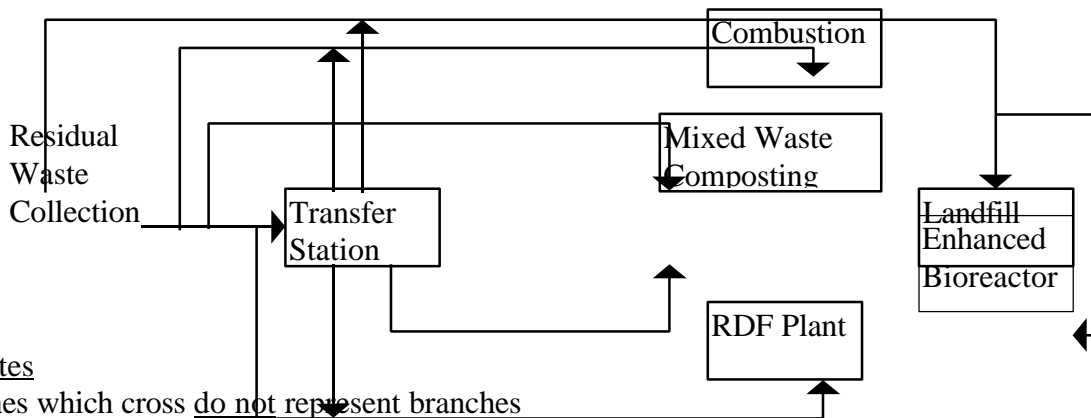

Notes

Lines which cross do not represent branches

Waste transport downstream of MRF's, combustion facilities, anaerobic composting and RDF plants is not shown for simplicity. These flows are considered in the system.

Figure 4g - Transport of Recyclables from a Drop-off Station (Collection Option 8)

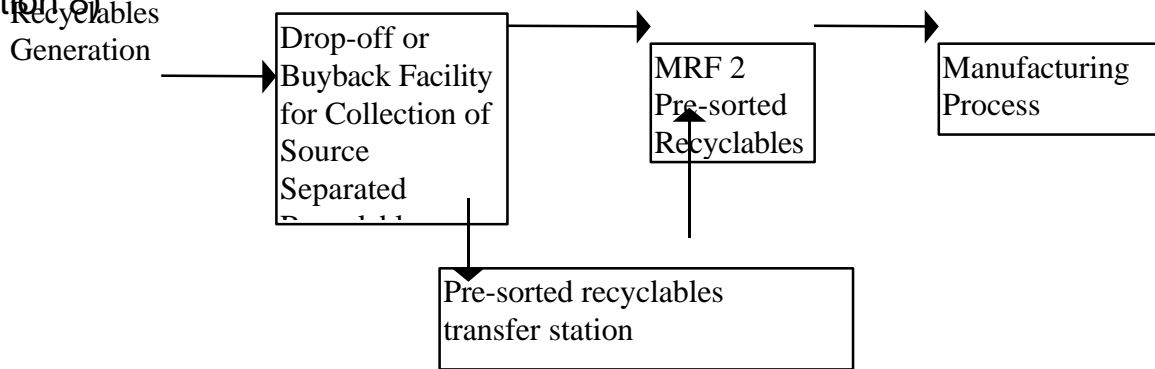
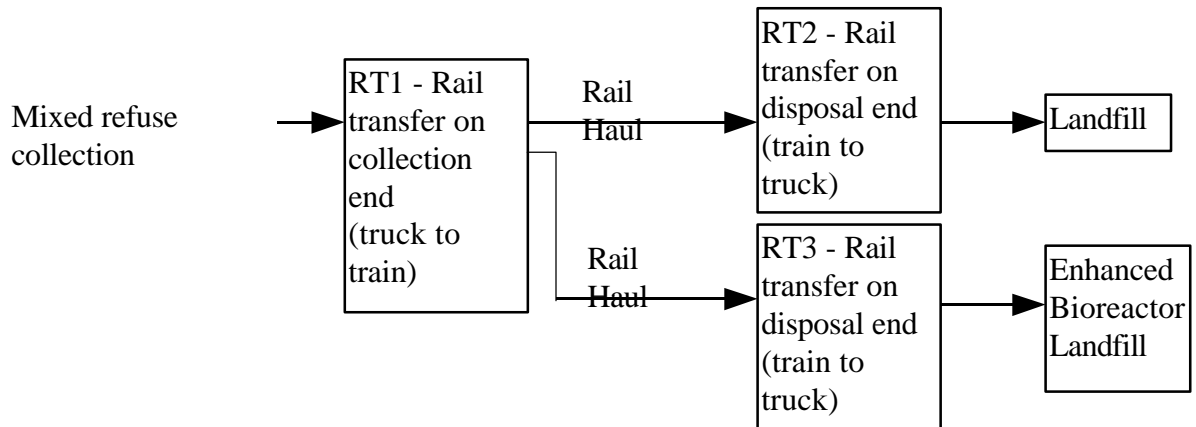

Figure 4h - Role of Rail Transfer Stations (Collection Options 1, 7, 11-13, 16-18 and 20)



The transport of recyclables to and from drop-off facilities is illustrated in Figure 4g. Here, recyclables may be transported to a MRF designed to process presorted recyclables (MRF-2), either through or around a transfer station.

The final collection options involve yard waste including (a) the collection of yard waste in dedicated vehicles (option 0), (b) dedicated leaf collection in vacuum trucks (option 9) and yard waste drop-off (option 10). Transfer stations are not involved in these collection options.

Finally, the system will include the transport of mixed refuse in rail cars. The refuse collected in options 1, 7, 11-13, 16-18 and 20 could be transported to a facility designed to place the refuse in rail cars. This is illustrated in Figure 4h. Refuse transported in rail cars is directed to one of two receiving rail transfer stations. These receiving stations are assumed to be adjacent to either a dry or enhanced bioreactor landfill.

## **7. MATERIAL RECOVERY FACILITIES**

In MSW management strategies where materials recycling is utilized, recyclables will require processing in a MRF. The design of a MRF is dependent upon the manner in which refuse is collected and subsequently delivered to the MRF. Thus, the collection and recycling of MSW are interrelated. This interrelatedness is captured in the system.

The unique design features of each MRF will have an impact on their cost as well as parameters included in the LCI. Eight distinct MRFs are considered in the system as described below.

- MRF 1:** receives mixed refuse as collected in collection options 1 or 13.
- MRF 2:** receives presorted recyclables. Such recyclables could be generated in collection options 2, 3, 8, 14, or 19.
- MRF 3:** receives commingled recyclables as generated in collection options 4, 5, 6, 11, 15, or 17.
- MRF 4:** receives mixed refuse, commingled non-paper recyclables, and paper recyclables as delivered in a vehicle with one compartment (collection option 5). We will refer to black bags as the color bag containing refuse and blue bags as the color bag containing commingled recyclables.
- MRF 5:** receives non-paper recyclables and paper recyclables in separate blue bags (collection option 6). The commingled recyclables are handled as in MRF 3. MRF 5 also serves as a transfer station for the mixed refuse present in a separate compartment of the vehicle.
- MRF 6:** is a front end MRF to a mixed waste composting facility. This MRF is at the

front-end of a mixed waste composting facility, i.e., the material recovery operations precede composting operations. The MRF is similar to a mixed waste MRF, but includes provisions for additional sorting to remove contaminants from mixed waste that affect the composting product.

**MRF 7:** is a front end MRF to an anaerobic digestion facility: This MRF is at the front end of an anaerobic digestion facility, i.e., material recovery operations precede anaerobic digestion operations. The MRF is similar to a mixed waste MRF, but includes additional sorting to remove contaminants that could adversely affect the anaerobic digestion process, or the quality of the digested solids.

**MRF 8:** is a front-end MRF to a refuse derived fuel (RDF) facility. This MRF is at the front end of an RDF facility, i.e., material recovery operations precede RDF operations. The MRF is similar to a mixed waste MRF, but does not include a magnet and eddy current separator for recovery of ferrous cans and aluminum. These waste components are recovered in the RDF facility.



**TABLE 2. MATERIALS WHICH CAN BE RECYCLED AT EACH MRF TYPE**

Recyclable Component	MRF 1 Mixed Refuse	MRF 2 Presorted Recyclables	MRF 3 Commingled Recyclables	MRF 4 Co-collection Single Comp.	MRF 5 Co-collection Double Comp.	Drop-Off or Buyback Center
						X
Fe-cans	X	X	X	X	X	
Al-cans	X	X	X	X	X	X
clear glass	X	X	X	X	X	X
brown glass	X	X	X	X	X	X
green glass	X	X	X	X	X	X
mixed color glass	X	X	X	X	X	X
t-HDPE	X	X	X	X	X	X
p-HDPE	X	X	X	X	X	X
PET-bvg.	X	X	X	X	X	X
plastic-other	X	X	X	X	X	X
mixed plastics <sup>a</sup>	X	X	X	X	X	X
ONP	X	X	X	X	X	X
O C C	X	X				X
office paper		X	X	X	X	X
paper-other		X	X	X	X	X
mixed paper <sup>a</sup>	X	X	X	X	X	X

<sup>a</sup>Includes "non-recyclable" plastics or paper.

Based on previous work, we have concluded that the MRFs described above are most cost effective when they include an automatic bag opener, a magnet for ferrous metal removal and an eddy current separator for aluminum can removal. All other sorting is performed manually. We propose to adopt these assumptions here, for purposes of developing MRF designs from which to estimate cost and LCI parameters. However, the user will have the opportunity to specify automated or manual equipment in certain cases.

The components of MSW which can be recovered in each of the different MRFs are listed in Table 2. This table also lists the components which can be accepted at a drop-off facility (collection option 8).

The technology associated with MSW sorting in MRFs is evolving. This can be accommodated

by allowing the user to bypass the MRF design and input costs directly. Eight distinct MRFs are required as described above. However, they have many overlapping design features which will remain consistent between MRFs. The design for each MRF will be presented in detail as part of the process model for MRFs.

## 8. REMANUFACTURING AND ENERGY RECOVERY

As part of the LCI, we must account for all resources, energy, and environmental releases associated with the recycling and reprocessing of a waste component. This section presents the conceptual framework which we propose to use to account for resource expenditures and potential savings due to the use of recycled materials. In management strategies where some portion of the MSW is recycled, the recyclables will ultimately be delivered to a facility for remanufacturing. Separation will occur during collection, at a MRF, or at another waste management facility.

Energy and resources will be expended to deliver recyclables to a remanufacturing facility. At the facility, additional energy and resources will be expended to convert the recyclables to a new product. The total amount of energy required to recover the recyclable from the waste stream and convert it to a new product will be included in the inventory analysis. This energy is termed ( $E_r$ ). In addition, the amount of energy required to produce a similar amount of product from virgin material will be calculated. This energy is termed ( $E_v$ ). The net amount of energy ( $E_n$ ) expended (or saved) to recycle a material will then be calculated as the difference between ( $E_r$ ) and ( $E_v$ ), where ( $E_n = E_r - E_v$ ).

While energy has been used here as an example, a similar calculation will be performed for all LCI parameters involved in the remanufacturing process such as carbon dioxide and other air emissions, wastewater pollutants, and solid waste, etc. This calculation assumes that a product manufactured using recycled materials is indistinguishable from the same product manufactured with virgin materials. Although not shown in Figure 5, ONP which is not recycled would be disposed by combustion, conversion to RDF, composting, or a landfill as illustrated in Figure 2.

The calculation described above is illustrated conceptually for ONP in Figure 5. Figure 5 shows the flow diagram which accounts for the total energy required to produce and deliver to consumers 1000 tons of newsprint (as newspapers). As can be seen in Figure 5, newsprint is not produced from 100% recycled material; some virgin material is mixed with the recycled fiber.

To develop the LCI, an assumption must be made with respect to which remanufacturing process is utilized for a recyclable. In the case of ONP, the major use is the production of new newsprint. However, some ONP is used in other applications (containerboard, cellulose insulation, animal bedding, etc.). For each recyclable, it will be necessary to collect data on remanufacturing processes to complete the LCI. Data collection efforts will focus initially on the major remanufacturing process for each recyclable. Additional remanufacturing processes will be

included to the extent that resources are available to collect data on more than one remanufacturing process. The system is designed with the capacity to incorporate more than one remanufacturing process into the analysis.

Figure 5  
 Illustration of Framework for Calculation of  
 Life Cycle Effects Including Remanufacturing for Recycled Newsprint

A. Calculation of  $E_r$

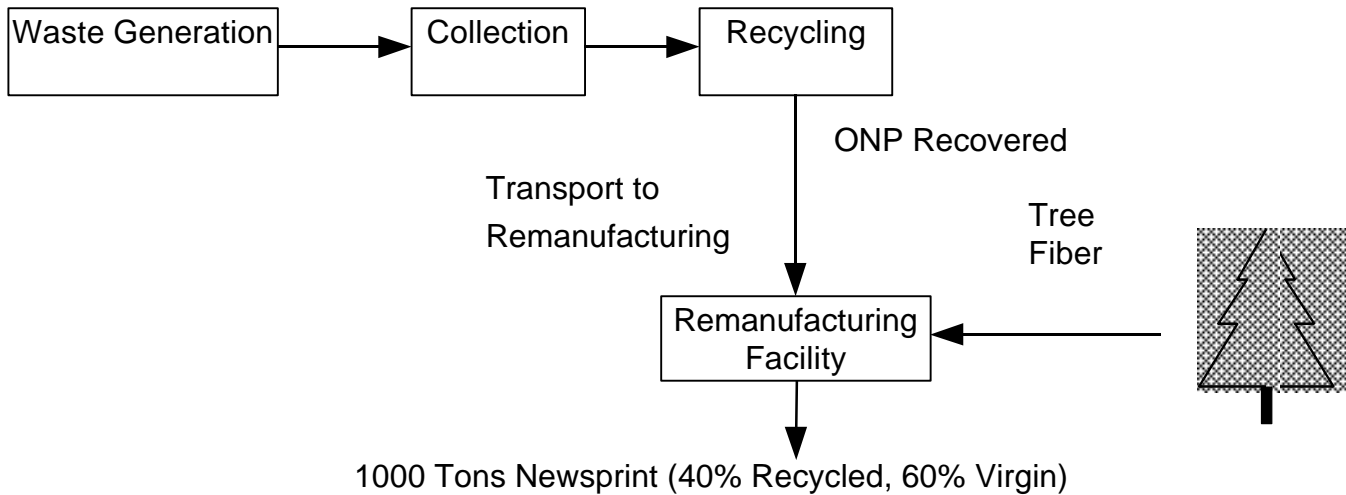

$E_r$  = Total energy required to produce 1000  
 Tons of newsprint using recycled material,  
 from collection through new product production.

B. Calculation of  $E_v$

$E_v$  = Total energy required to produce 1000  
 Tons of newsprint from virgin material. Includes  
 energy from growth of trees through final product.

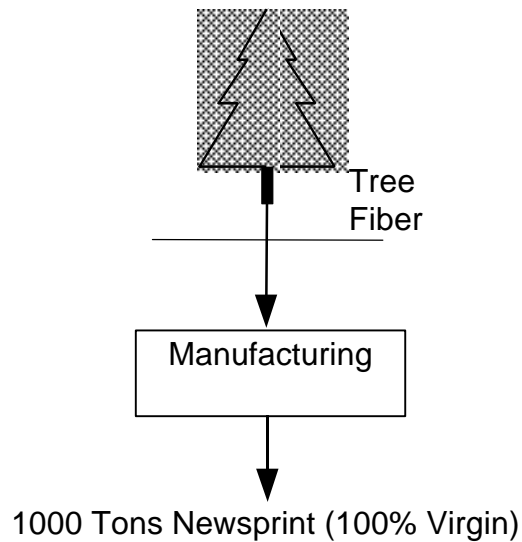

In addition to recycled materials, an offset will also be required in management strategies where energy is recovered from either the direct combustion of MSW, RDF, or landfill gas. The conceptual framework described above may be applied here as well. Energy recovered from the MSW will be credited to that management strategy. In calculating emissions reductions associated with energy recovery, we assume that any “saved” electrical energy resulted from fossil fuel (coal, oil, or natural gas) and not from hydro or nuclear power.

## **9. COMPOSTING**

Composting is the aerobic biodegradation of organic matter and is considered as a treatment alternative. We propose to consider composting of yard waste and mixed waste. Yard waste composting may occur in either a centralized municipal facility or in a generator's backyard. Here, we consider a centralized composting facility. Backyard composting will be considered in Section 14 on source reduction.

We propose to consider two alternatives for yard waste composting; a low and medium technology facility. The major difference between these two facilities is the degradation rate of the yard waste as influenced by the turning frequency. The detention times are assumed to be 540 and 270 days for the low and medium technology facilities, respectively. Turning is accomplished with either a front end loader once per year (low) or a windrow turner 25 times per year (medium). Other major differences between the low and medium technology facilities include water addition, post process screening and the potential to treat leachate. The type of facility to be considered will be a user input parameter. Neither facility includes an automated air supply system. Branches will be shredded prior to composting in both the low and medium technology facilities.

Yard waste may be delivered in collection vehicles or dropped off by the waste generator. In addition, leaves may be delivered in vacuum trucks. If yard waste is delivered in bags, then the user will be asked to specify whether the bags are biodegradable, in which case they will not require emptying, or non-biodegradable, in which case they will need to be emptied and the bags will represent a residual. Yard waste may also be delivered in bulk.

The design of the mixed waste composting facility will be based on mechanical aeration. The facility will include preprocessing of the incoming waste stream to remove any non-compostable recyclables such as glass, metal, and plastic as well as any non-compostable non-recyclables. The waste flow equations are written so that paper may or may not be removed in the preprocessing step.

## **10. WASTE-TO-ENERGY COMBUSTION**

Combustion represents a treatment alternative in which the volume of MSW requiring burial is significantly reduced. We consider a waste-to-energy (WTE) combustion facility in which MSW is burned with subsequent energy recovery in the form of electricity. Facilities in which energy is not recovered as well as facilities in which energy is recovered as steam are excluded from the system. The rationale for this selection is that the majority of combustion facilities constructed today include energy recovery as electricity.

The cost, energy production, and emission factors for the WTE combustion facility will be developed on the basis of BTU of input waste per day, as opposed to tons per day which is more standard. In so doing, we are able to link the cost and energy yield of combustion to waste composition. The BTU value of the waste input to a combustion facility will be calculated from default data on the BTU value of individual waste components and the composition of waste entering the facility. Thus, if the BTU value of MSW changes, the effect will be incorporated into estimates of potential energy recovery. This will allow comparison of the relative net benefits of recycling and combustion with energy recovery in the optimization module.

For a combustion facility to be feasible, a critical mass of refuse is required. The critical mass will be set up as an input parameter so that (1) a solid waste management alternative with an unacceptably small combustion facility is not proposed and (2) future changes in technology resulting in a change in the critical mass can be incorporated in the system. The combustion facility will include appropriate air pollution control equipment to meet current regulations.

## **11. REFUSE DERIVED FUEL (RDF) AND CO-COMBUSTION**

In addition to combustion as discussed in the previous section, two alternatives for recovery of the energy value of MSW will be considered in the solid waste management system, RDF and co-combustion. In the system described here, RDF production refers to the separation of MSW into a product stream with a relatively high BTU value and a residual stream with a relatively low BTU value. Of course, the efficiency of the separation of MSW into these streams will be less than 100%. There are many variations on the RDF theme including the production of shredded refuse for direct combustion, and the production of pellets for shipment over longer distances. The most common RDF processes will be identified in future work so that one or more generic RDF plant designs can be developed. These designs will be used as the basis for which cost, energy, and emission factors are developed.

The division between an RDF plant and a MRF is not entirely distinct as metals separation typically occurs in an RDF plant. Thus, if RDF is part of an MSW management strategy, then it would probably not be necessary to remove tin cans separately. Similarly, an eddy current separator at an RDF plant would eliminate its need at a MRF. As more information is developed

on RDF plants, we will propose the manner in which the interrelationship between an RDF plant and a MRF will be handled.

Another manner in which energy can be recovered from MSW is by the combustion of particular components of the stream in industrial boilers. This could include utility boilers, hog fuel boilers in the paper industry and the like. The system allows for the recovery of a mixed waste paper stream and a mixed waste plastics stream during recycling. One or both of these streams could be used as fuel for an industrial boiler.

## **12. ANAEROBIC DIGESTION**

Anaerobic digestion of MSW could occur in either a reactor or by operation of a landfill with leachate recycling for enhanced refuse decomposition and methane production. Here we refer to digestion in a reactor. The facility will include preprocessing of the incoming waste stream to remove any non-degradable recyclables such as glass, metal, and plastic as well as any non-degradable non-recyclables. The waste flow equations are written so that paper may or may not be removed in the preprocessing step.

## **13. LANDFILLS**

Three types of landfills will be considered in the system; one designed for the receipt of mixed refuse and a second designed for the receipt of ash only. The mixed refuse landfill will be designed according to RCRA Subtitle D and Clean Air Act standards. However, the user will have the opportunity to specify either a more lenient or stricter design with respect to the liner and cover systems. The landfill will be operated as a dry landfill. Consideration of the operation of a landfill with leachate recycle for enhanced decomposition and methane production was discussed in the previous section. The system will include both gaseous and liquid releases from the landfill. The user will be required to specify whether gas is flared, recovered for energy, vented to the atmosphere or allowed to diffuse out of the landfill. This information, coupled with data on landfill gas production, will be used to estimate atmospheric emissions. Estimates will also be developed for the amount of leachate requiring treatment. This leachate will be treated in an offsite treatment facility. Energy and emissions associated with leachate treatment will be considered in the LCI.

Municipal waste combustion ash will be directed to a second landfill designed to accept ash. Even when a community utilizes combustion, there will be some material which should not be routed to a combustion facility and also times when it is out of service. Thus, we expect that the design for an ash landfill will include a relatively small section designed for the receipt of mixed refuse.

A third landfill will be designed with leachate recycling to enhance refuse decomposition, methane production, and leachate treatment. As above, the system will include both gaseous and liquid emissions. The user will be required to specify whether gas is flared or recovered for energy.

This information, coupled with data on landfill gas production, will be used to estimate atmospheric emissions.

#### **14. SOURCE REDUCTION**

As illustrated in Figure 1, source reduction represents the difference between potential and actual waste generation. Source reduction represents a reduction in mass or toxicity. Source reduction may lead to reductions in other LCI parameters such as COD production or particulate emissions. The effects of source reduction are unique to very specific components of the waste stream. The conceptual framework for modeling source reduction is described first, followed by examples of how it could be applied.

With reference to Figure 1, the box entitled source reduction represents a series of multipliers that adjust the waste generation rate resulting from a source reduction program. These numbers are multiplied by the waste quantities in the potential waste generation box to calculate actual waste generation. Source reduction will include a series of multipliers, with unique values for changes in waste mass and each LCI parameter. These multipliers will be set up as individual input parameters in a preprocessor so that where the user has data on a specific process, it can be used. Collection of data on specific industrial processes for evaluation of source reduction is beyond the scope of this project.

Source reduction is generally applied to very specific components of the waste stream. Examples might include a lighter napkin with equivalent absorbency, or a napkin produced by an alternative manufacturing process which reduces waste production. Napkins are not one of the waste components listed in Table 1. Rather than divide the waste stream into the individual components which make up MSW in order to specifically include napkins, we propose to provide additional “dummy waste components” in the waste composition data input section. These dummy variables could be used in the same way as the “paper-other” category. That is, if a user wishes to focus on napkins, then the user would consider one of the dummy variables to be napkins and then enter the appropriate multipliers to account for mass and other LCI parameter reductions (or increases) associated with the production of a different napkin. If a waste were to be converted from a non-recyclable to a recyclable form, then its composition would have to be considered as part of one of the recyclable components identified in Table 2. If this is inappropriate, then the waste generation model will require modification.

A simpler example of the source reduction is backyard composting. Here, yard waste which is composted by the waste generator does not enter the MSW collection system. A multiplier would be used to reflect the decreased mass of yard waste in MSW. Yard waste not collected would not require energy for collection or further processing in a centralized composting facility. However, there are life-cycle effects associated with backyard composting and these are accounted for in a dedicated process model. The backyard composting process model will account for emissions associated with biodegradation as well as emissions associated with the use of a chipper for size



reduction of branches. In the process model, the user will have to specify the fraction of backyard compost where a chipper is utilized.

## **15. SUMMARY OF SYSTEM BOUNDARIES**

The system has largely been defined through the description of the functional elements and unit operations, as presented in this document, and the manner in which each will be treated. This section provides a summary of the system boundaries and explains how and why the boundaries for the environmental(LCI) analysis are different from the boundaries used for cost analysis.

### **15.1 System Boundaries for LCI**

In general, we will evaluate all data which have a bearing on the LCI from materials acquisition through waste disposal or remanufacturing. Where a material is recycled and a new product is produced, the resources, energy, and environmental releases associated with production of the new product, as well as those saved by using a recycled material instead of a virgin material, will be considered. This concept also applies to energy recovery from combustion as described in more detail in Section H and in Figure 5.

In considering remanufacturing, we will evaluate LCI parameters from the recovery of a raw material through its conversion to a product. Where petroleum is a raw material, the analysis would include all activity beginning with recovery of petroleum from the earth. Where energy is required in a process, the energy associated with production of the energy (precombustion energy) and the wastes associated with energy production will be considered. Where trees are utilized, resources associated with growing and harvesting the tree will be considered.

The functional elements of MSW management include numerous pieces of capital equipment from refuse collection vehicles to balers to major equipment at paper mills. Resources are associated with the fabrication of capital equipment as well as the construction of a new facility. In theory, these resources should be considered in the LCI. This may be particularly relevant in evaluation of waste management strategies which suggest the construction of a new facility, such as a MRF, or the purchase of new refuse collection vehicles. While inclusion of capital equipment appears to be theoretically correct, it introduces additional complexity which may not be necessary. Sensitivity analysis will be used as a screen to evaluate the importance of its inclusion in the LCI. It is difficult to identify cases where capital equipment and facility construction can or cannot be neglected ahead of time and issues such as this will be brought out for discussion as they arise.

A second type of resource that may be neglected is the energy associated with the operation of a facility's infrastructure, or "overhead" energy. For example, energy will be expended for the operation of refuse collection vehicles. We expect that a much smaller amount of energy will be expended for operation of the office through which the vehicle routes are developed and the collection workers are supervised. Our hope is to obtain estimates of this "overhead" energy

based on utility bills. If this energy is less than 5% of the energy utilized by the collection vehicles, then it will be neglected unless standard overhead energy consumption factors are available. This will save the project the resources required to estimate such energy more precisely and will not affect the quality of the project output.

Another system boundary is that at the waste treatment and disposal end of the system. Where wastes are generated which require treatment, the energy associated with their treatment will be considered. If a solid waste is produced which requires burial, energy will be consumed in the transport of that waste to a landfill and its burial in the landfill.

## **15.2 System Boundaries for Cost Analysis**

In this section, we propose that the system boundary for cost analysis differ from that of the LCI.

We propose that our cost analysis focus on the cost of waste management as experienced by the public sector. Thus, the cost analysis will include the cost of waste collection, transfer stations, MRFs, composting facilities, combustion, RDF plants, and landfills. In addition, where a waste is produced as part of a waste management facility, the cost of waste treatment will be included in the cost analysis of that facility. For example, we will include the cost of leachate treatment in our cost analysis of landfills. The cost analysis boundary will also include the cost of educational or other materials associated with source reduction or other aspects of solid waste management.

The boundary for the cost analysis will be drawn at the points where waste is buried and recyclables are shipped to a downstream processor. For example, if recyclables were shipped from a MRF, the cost analysis would end where the public sector received revenue (or incurred a cost) in exchange for recyclables. The same analysis would apply to the sale of RDF or electricity. The user must be cautioned that there are situations where the revenue realized from the sale of a recyclable is artificially high. This has occurred in the past where a manufacturer has taken steps to encourage the recycling of a material by offering an artificially high price. Such situations may arise when recycling of a waste component not typically recycled begins. This situation would not be expected to persist for a period of several years.

One cost to be excluded from the cost analysis is the cost of remanufacturing. However, we feel that this cost is reflected in the price paid to a community for recyclables or electricity.

The user will have the option to enter costs directly if known, or provide sufficient design information to estimate costs. Where costs are estimated, we propose to estimate costs in the absence of an allowance for profit. The user could then be given the opportunity to specify a profit margin if the user expects that a waste management unit operation will not be operated in the public sector. The calculated cost will then be adjusted upwards prior to its use.

In summary, by focusing on costs incurred in the public sector, the analysis will be of most use to local officials responsible for development of strategies for solid waste management.

## **REFERENCES**

U.S. Environmental Protection Agency. 1994. *Characterization of Municipal Solid Waste in the United States: 1992 Update*. EPA/530-R-94-042. Office of Solid Waste, Washington, DC.