

2.0 TECHNICAL CRITERIA

2.1 Codes and Standards

2.1.1 National Codes and References

The Department of Veterans Affairs requires consultants to use the latest editions of codes and standards for all projects. Among the required codes and standards are:

1. VA Directives, Design Manuals, Master Specifications and other guidance in the Technical Information Library (TIL)
<http://www.va.gov/facmgt/standard>.
2. *Occupational, Safety and Health Administration (OSHA) standards.*
3. *National Fire Protection Association (NFPA) codes.*
4. *National Electrical Code (NEC).*
5. *International Building Code, 2003 Edition (IBC 2003).*
6. *Uniform Building Code, 1997 Edition (UBC 1997), for other building elements.*
7. *National Standard Plumbing Code (NSPC).*
8. *Safety Code for Elevators and Escalators A 17.1*, published by American Society of Mechanical Engineers (ASME),
9. *Uniform Federal Accessibility Standards (UFAS)*, including Barrier Free Design Guide; A Supplement to the UFAS (DVA PG-18-13; February 1997).
10. *Building Code Requirements for Reinforced Concrete (ACI 318)*, published by the American Concrete Institute.
11. *Specifications for the Design, Fabrication, and Erection of Structural Steel for Buildings*, published by the American Institute of Steel Construction (AISC).
12. *Energy Code for New Federal Commercial and Multi-Family High Rise Residential Buildings; Final Rule*, (mandatory for new federal buildings), Department of Energy (DOE) Regulations, 10 Code of Federal Regulations (CFR) Parts 434 and 435.
13. *Provisions for Construction and Safety Signs*, stated in General Requirements Section 01010 of the VA Master Construction Specification.
14. *Greening the Government through Efficient Energy Management – Executive Order 13123.*
15. *Greening the Government through Leadership in Environmental Management – Executive Order 13148.*
16. *Ventilation for Acceptable Indoor Air Quality – ASHRAE Standard 62-2001*, published by the American Society of Heating, Refrigerating and Air-Conditioning Engineers, Inc.
17. *Safety Standard for Refrigeration Systems – ASHRAE Standard 15-2001*, published by the American Society of Heating, Refrigerating and Air-Conditioning Engineers, Inc.
18. *Humidity Control Design Guide for Commercial and Institutional Buildings; Chapter 25: Eldercare Buildings - 2001*, published by the American Society of Heating, Refrigerating and Air-Conditioning Engineers, Inc.

The current profiles of VA clients indicate that a high percentage of residents require assistance in activities of daily living such as toileting and showering. The VA *Barrier Free* supplement PG-18-13 establishes requirements, which differ from those of UFAS. The more stringent requirement is to be followed. It is recommended that Nursing Homes serving our nation's Veterans adhere to the requirements of PG-18-13, and provide accessibility in 100% of bedrooms and resident toilets designed to accommodate both male and female Nursing Home veterans.

VA Nursing Home clients include an increasing percentage of male residents who are larger and heavier than the smaller and female resident populations in most community Nursing Homes. Typical staff assisted activities for veterans, such as transportation, toileting, bathing, showering, and transfers to and from wheelchairs and beds, requires frequent use of lift devices.

Older VA residents may use toilets and wheelchairs differently than their younger and stronger counterparts. A departure from standard ADA and UFAS requirements regarding toilet and grab bar configurations and dimensions is therefore recommended. This will facilitate safe, staff-assisted transfers of residents in toilet rooms and similar locations. Older residents typically do not turn their wheelchairs in a circle. Residents are not successful in turning within a 5'-0" diameter circle. A 5'-6" minimum clear area is recommended.

This Design Guide recommends departures from the ADA, UFAS and VA PG-18-13 standards regarding transfers

to toilets. The VA has initiated discussions with the staff of the Access Board regarding modifications of the ADA and ADAAG design guidelines, in an effort to accommodate staff-assisted activities in Nursing Homes and similar care giving facilities.

2.1.2 Local Codes and References

VA is not subject to local imposition of code enforcement procedures, such as drawing reviews, building permits, inspections, fees, etc. Therefore, VA functions as the Authority Having Jurisdiction for all VA facilities and projects. SVH's and other Nursing Homes serving United States Veterans are not VA facilities and must comply with local codes and enforcement procedures.

2.1.3 Other Recommended Reference Standards

The following consensus documents provide additional guidance and useful insights into the minimum functional requirements of Nursing Home design:

1. Guidelines for Design and Construction of Hospital and Health Care Facilities, 2001 Edition (Guidelines 2001), published by the American Institute of Architects Academy of Architecture for Health and the Facilities Guidelines Institute, with assistance from the U.S. Department of Health and Human Services.
2. Recommended Practice for Lighting and the Visual Environment for Senior Living, (IESNA RP-28-98), published by

the Illuminating Engineering Society of North America (IESNA), and adopted as an Approved American National Standard (ANSI RP-28-2001).

2.1.4 OBRA 1987/NHRA

The Nursing Home Reform Act (NHRA) of 1987 (PL 100-203) was an outgrowth of the Omnibus Budget Reconciliation Act of 1987. OBRA 1987 probably has had more impact than any other single piece of legislation regarding Nursing Homes in the United States as well as the culture and philosophy of caregiving within them.

NHRA guaranteed Nursing Home residents certain rights and protections, including, but not limited to:

- Access to all of the nursing and rehabilitation services offered by a facility that may be needed to enable a resident to attain his/her highest practical level of independence and physical, mental and psycho-social function
- Development of an on-going program of care and activities designed to meet the specific needs and interests of each individual resident
- The right to participate and/or be represented in care planning, along with certain rights of privacy and dignity
- The right to be free from physical and chemical restraints.

The immediate effect of NHRA/OBRA '87 was the changes in state codes and regulations designed to incorporate the NHRA requirements into state Medicare and Medicaid reimbursement policies.

Additionally, there were gradual changes in minimum space standards. NHRA initiated an evolution of stronger social, recreational, rehabilitative and meaningful activities programs such as:

- Personalization of rooms and the development of "homelike" residential environments,
- Better food service programs,
- Recreational activities and wandering gardens,
- Expansions of physical and occupational therapies, activities of daily living and dementia programs,
- The incorporation of engaging environmental stimuli, and
- The recruitment of volunteers, families and other residents in stimulating daily experiences.

2.1.5 HIPAA

The Healthcare Insurance Portability and Accountability Act of 1996 (HIPAA) has reinforced and extended NHRA emphasis on privacy and dignity, to include audible as well as visual privacy. This is especially the case with respect to protection of each individual's medical records, private information and communications. This law protects all conversations between residents and admission interviewers, caregivers, nurses, physicians and families. Serious breaches of those rights to privacy are subject to Federal litigation.

HIPAA is currently having an impact on the design of resident rooms in terms of audible privacy in standard two-person room layouts where only a cubicle curtain separates resident beds. Resident unit layouts now consider the juxtaposition of rooms and spaces, which may limit sounds of private

conversations from being overheard. Planning of staff stations, reception desks, conference rooms, offices, treatment and therapy rooms, where exposed private records may be seen and conversations overheard by unauthorized persons, should also consider privacy during design

2.1.6 Life Safety

Successful strategies have long been available for making a sprinkler system inconspicuous. However, in new construction, achieving “homelike” residential environments remains a significant challenge when attempting to incorporate fire safety and egress provisions required for Nursing Home occupancies under contemporary codes.

Nursing Home life safety issues that require attention include evacuation standards and disaster planning. Among them are the following:

1. Evacuation Standards

Eighty percent of Nursing Home residents may suffer from some degree of dementia. Those who may be so afflicted can become frightened and confused if awakened by an evacuation alarm in the middle of the night. Given the limited staff that may be available to assist residents on some shifts, vertical evacuation from even one floor above grade may simply not be practical. Many people prefer to depend upon horizontal Nursing Home evacuation plans.

For some Nursing Home administrators, this means building only single story Nursing Homes, or perhaps a two-story building built on a hillside in which each

floor may exit on grade. Multi-story buildings must consider planning for horizontal evacuation to a safe area of refuge. This includes:

- Planning the facility so that each floor is divided into at least two compartments separated by a rated firewall. The firewall extends throughout the full height of the building.
- Openings in this firewall are strictly limited to ducts equipped with automatic fire dampers and horizontal exits across corridors.
- Doors opening in opposite directions in egress corridors are recommended so that occupants in either smoke compartment may safely exit to an area of refuge on the other side of that wall.
- A fully sprinklered building where each smoke compartment has at least two other means of egress.
- An area of refuge on each side of the firewall sized to accommodate the entire adjacent zone population that could be present on the other side of the barrier.

Elopement of dementia residents whether deliberate or accidental, can threaten the resident’s health and safety, and represents risk for any Nursing Home. Suburban and rural sites may present opportunities for keeping such a resident safely contained within a controlled perimeter such as a wandering garden. An urban site and many suburban sites may not offer such an opportunity. Many Nursing Homes prefer to restrict travel out of a dementia unit by using a delayed egress locking system. Such systems will typically open immediately in response to a staff member having a

key, or by pressing a code on a key pad. Most of these systems also will respond to a resident attempted departure after 15 seconds of continuous pressure on the exit door, by which time alert staff should be able to respond to the alarm in the event of an unauthorized exit.

The 2003 Edition of the IBC states that resident units may not be locked-down for any reason, regardless of the circumstances. Thus, delayed egress locking systems are not permitted in states, which have adopted IBC 2003.

2. *Disaster Planning*

Situations can arise in which it may not be feasible to evacuate residents for days, weeks, or months. In those cases, emergency power will be required to maintain food service, heating, ventilating and vertical transportation systems, and life safety systems. This is especially important to keep a frail resident population reasonably comfortable and safe. This Design Guide recommends that the project consider planning for this contingency in order to care for the veteran population especially when the facility is located in an area where a high probability of threat exists from natural disasters such as hurricanes and earthquakes.

Page Left Intentionally Blank



2.2 Site Considerations

2.2.1 Introduction

Site analysis and planning are influential to the success of a project. At the beginning of the design process, the design team should perform several preliminary analyses that will affect the final design of the facility. Several of the site related factors that are required for a Nursing Home care facility are mentioned in this section and are to be considered as essential tools for planning of a Nursing Home facility. Each project designer should consider the project specifics that include, but are not limited to:

- Site Area
- Site Geometry
- Local Zoning
- Topography
- Regional and Climatic Factors
- Utilities
- Other Site Characteristics

2.2.2 Planning

When planning a Nursing Home facility, consider the activities of the multiple users including the residents, staff, visitors, maintenance personnel, service providers, emergency crews and utility workers. The completed site should include:

- Landscaped Features
- Wander Garden
- Setbacks and Buffers
- Ample Parking for Staff and Visitors
- Access for Emergency Vehicles
- Utility and Service Access
- Covered Entry
- Signage - Wayfinding

To provide adequate planning and programming guidance, 12 study sites were reviewed for essential characteristics. The study sites varied in area, number of stories, unit size and number of beds.

1. *Generic Site Plan*

The generic site plan provided in this section (Figure 2.1) indicates a hypothetical solution for a 120 to 160 bed Nursing Home facility. The projections and assumptions for this plan are for reference purposes only, and are not meant to suggest a solution for a specific design problem. Features of this Generic Site are similar to those mentioned in this section.

The generic site plan illustrates:

- Single Story footprint
- Approximately 120-160 Beds
- Expansion potential could accommodate an additional 80 beds +/-

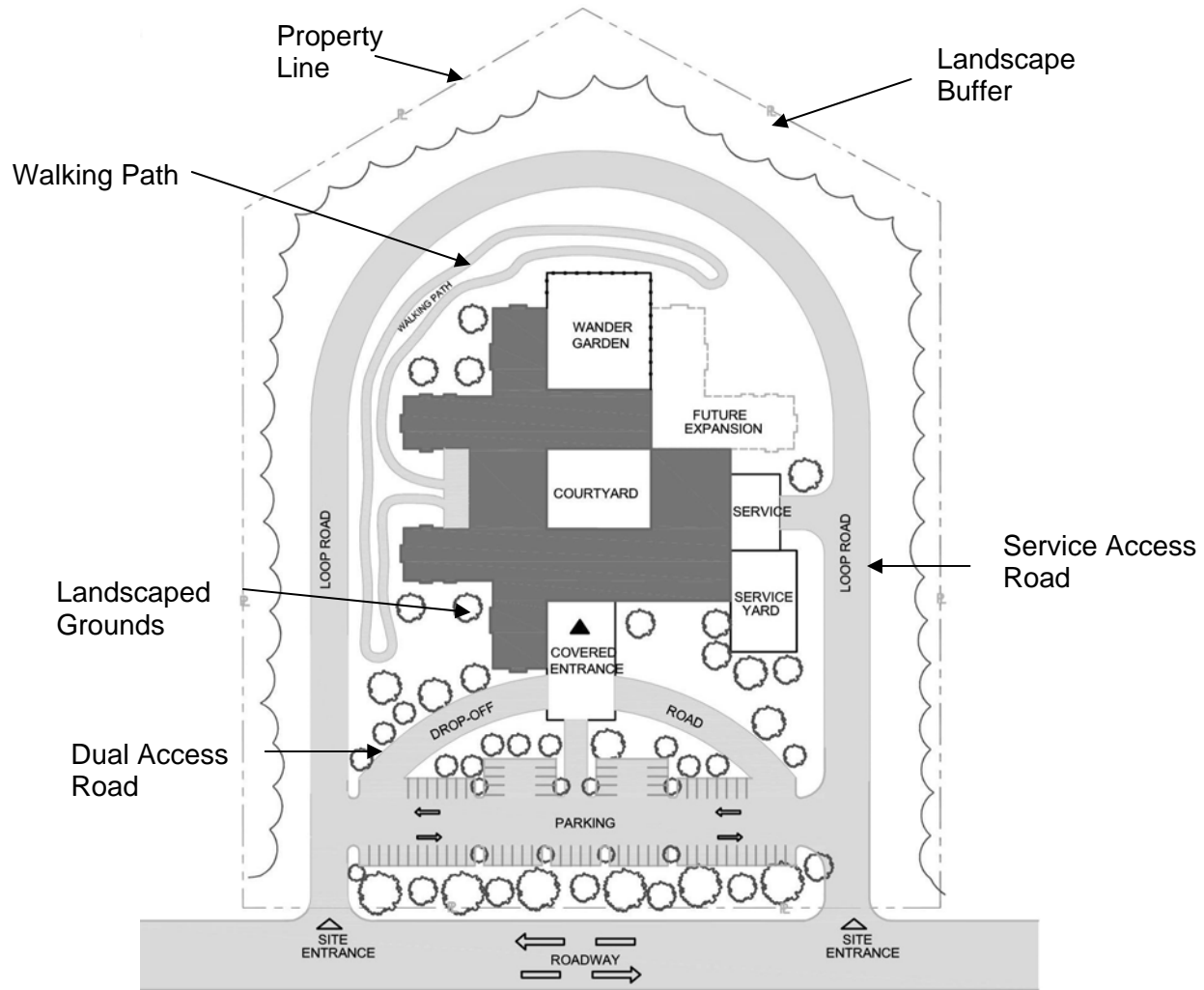

Figure 2.1

Generic Site Plan
NTS

2. Parking

The residents of Nursing Home facilities do little driving; therefore, the requirements for parking are generated by staff, visitors, service technicians and deliveries.

Table 2.1 lists data related to peak periods of 2pm to 4pm on a weekday. Site planning concepts for parking as indicated in Table 2.1 are based on Land Use: Section 620 Nursing Home, taken from the Institute of Transportation

Engineers (ITE). The table suggests an average of .37 parking spaces per bed during peak hours between 2 pm and 4 pm for visitors. The ITE review of their study sites indicates an average of 1.5 spaces per 1,000 sf for a Nursing Home facility. The number of beds, the number of staff, and the size of the facility all play a role in adequately sizing a parking area for a Nursing Home facility.

Statistic	Peak Period Demand
Peak Period	2:00 – 4:00 p.m.
Number of Study Sites	6
Average Size of Study Sites	160 beds
Average Peak Period Parking Demand	0.39 vehicles per bed
Standard Deviation	0.18
Coefficient of Variation	46%
Range	0.12 – 0.62 vehicles per bed
85 th Percentile	0.52 vehicles per bed
33 rd Percentile	0.35 vehicles per bed

Table 2.1
Parking Demand Table - Weekday

Parking Generation, 3rd Edition, 2004
Institute of Transportation Engineers

2.2.3 Topography

Topographical influences may effect the orientation of access points to the facility such as entrance, service, egress, parking, perimeter road for emergency, retaining walls, berms, landscaping and general location of the structure on the site (See Figure 2.2). During the planning phase of the project, consider what the impact of the topography of the site will have on the design. Walks, ramps, outcroppings and roadways are also features that are impacted by site topography. (See Figure 2.3) During the initial survey of the site, a physical

review of the site is recommended (See Figure 2.4). Large rock outcroppings could influence landscaping on site as well as the location of the facility on the site. Consider using major outcroppings as a landscaping feature on the project site.

Where possible, at-grade site access from the facility is desired. Existing on-site grading is an important consideration when planning and locating the access points of the facility.

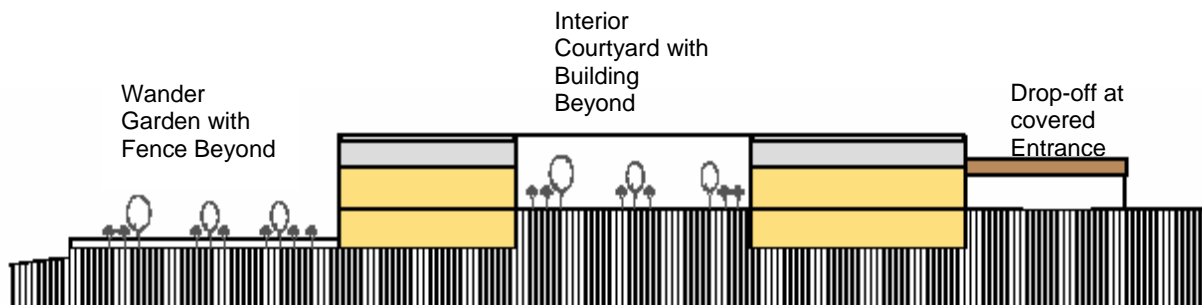

Figure 2.2

Generic Site Section: Multi-level Facility with Variation in Topography

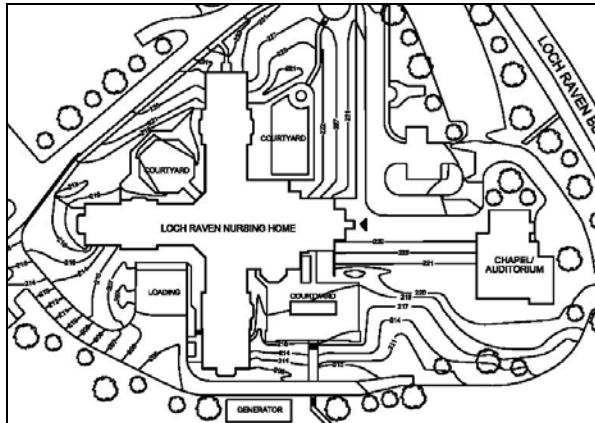

Figure 2.3

**Nursing Home Care Unit at Loch Raven
Baltimore, MD**



Figure 2.4

**Aerial Photo
Washington State Veterans Home
Retsil, WA (During Construction)**

2.2.4 Zoning

Unlike many general aspects of site design such as roadways and parking aisles, zoning is site specific. Preliminary plans should not advance without performing a zoning analysis. In the case of government-owned property, it is important to consider the zoning and

adjacencies for compatibility with neighboring buildings. Factors for zoning include:

- Height
- Lot Occupancy
- Number of Stories
- Parking
- Green Space
- Historic District
- F.A.R.
- Setbacks
- Use Groups

2.2.5 Historic Features

Early in the design phase, there should be an analysis, which determines whether there are any historic issues. As with the zoning analysis, the historic related issues and features are site specific. The impact of historic related issues includes: finish of the exterior; window types, colors and shapes; roof types and slopes; color of façade; height of facility and location of facility. Federal, state and local jurisdictions and related agencies should be contacted to assure that the guidelines in place are followed. In Figure 2.5, the Forwood building directly affected the window shape and size; the axis and shape of the King Health Center, US Soldiers and Airmen’s Home in Washington, DC. The site plan in Figure 2.8 illustrates the axis and geometric impact of the Forwood building on the US Soldiers and Airmen’s Home.



Figure 2.5
Forwood Building, US Soldiers and Airmen's Home

2.2.6 Roadways

1. Site Access

Site access roadways may be located directly at main public roadways. The location of curb cuts and aprons should be planned in accordance with local zoning code or AHJ.

2. On-Site Roadways

Width of roads should accommodate traffic in each direction. (See figure 2.6) A path from the site entrance to entry of the facility should be logical and easily identifiable.

Site roadways to and from parking areas should be capable of accommodating two-way traffic. Proper signage and direction arrows may enhance clarity of destinations and paths.

3. Emergency Roadways

Emergency access is required on the grounds of the facility. This access relates to ambulance, fire and rescue, law enforcement and other emergency related vehicles. The width of the roadway for emergency purposes should be maintained and unobstructed at all times.

A loop road or some means of complete site access is generally required in every jurisdiction. Loop road design should accommodate a fire truck, and enable emergency vehicles to access a complete revolution around the facility. At a minimum, access to every part of the site and facility for emergency vehicles must be provided.

4. Service Road

The service road may better serve the facility by having a separate access point. Should that not prove feasible due to site restrictions or other reasons, consider a separation of roadways upon entry to the site. Clearly indicate the service road and design it in such a way as to not interfere with general site access or emergency roadways. The service roadway should accommodate truck traffic in two directions unless the roadway system is designed and clearly identified as a one-way traffic pattern.



Figure 2.6
Service Road
Nursing Home Care Unit at Loch Raven, Baltimore, MD

2.2.7 Site Signage/Wayfinding

Locate signage on the site for visitors, staff and service accommodations. Some suggestions for site signage include:

- Directional Traffic (one-way)
- Restrictions
- Parking
- Deliveries
- Passenger Pick-up
- Entrance to Site
- Entrance to Facility

2.2.8 Proximity to Adjoining Facilities

Several Nursing Home facilities are affiliated with Federal or state medical center campuses. In either case, the foregoing topics are considered issues for site planning and design. Site access and roadways of an adjoining existing medical center are examples where a new Nursing Home facility may be able to utilize in-place vehicular pathways. (See Figure 2.7)

Adjoining or proximate facilities may influence or determine certain characteristics of the new facility.



Figure 2.7

Proximity to Existing Facilities
 (View from Loading Dock)
 State Veterans Home at Montrose

2.2.9 Shared Amenities

The nature of the site with respect to location and co-existence could influence several aspects of a facility. Shared amenities, for example, could impact:

- Siting of facility
- Orientation of entrance
- Location of services
- Access to site
- Availability of utilities

If physically affiliated, this physical connection may require the use of a common service road or a common entrance to the site in general. (See Figure 2.8 and 2.9) Independent access to power, communications, gas, water and other utilities is preferable, thereby enabling the facility to remain on line in the event of outages on the shared campus. Emergency power provisions for the facility should be a part of the planned program due to the needs of the residents.

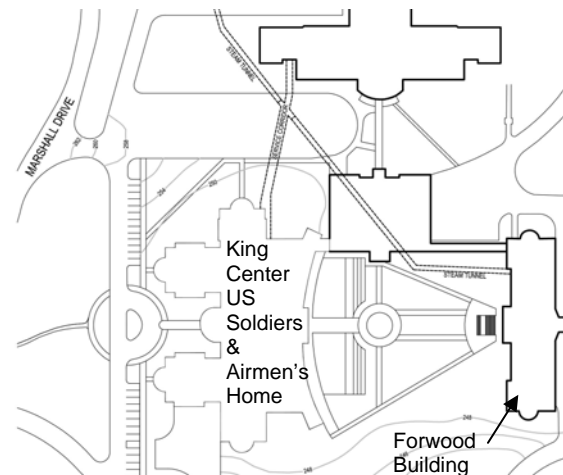

Figure 2.8

Shared Amenities
 U.S. Soldiers and Airmen's Home,
 Washington, DC

The advantage of sharing campus amenities include, but are not limited to:

- Access to site
- Services and utilities
- Possibility for use of existing on site features
- Existing buildings
- Medical facilities
- Outdoor amenities

Many of these items translate into cost savings over the life of the facility. These and other shared amenities significantly affect project costs.

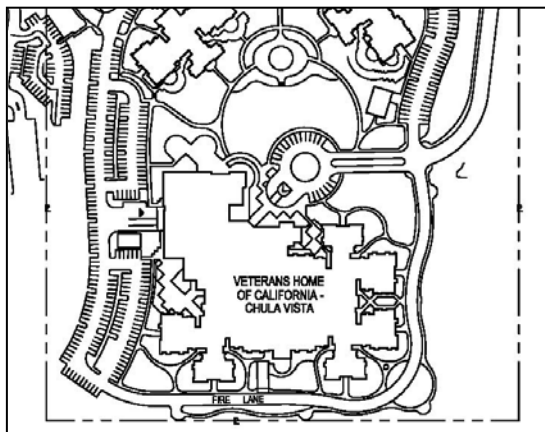

Figure 2.9

Parking and Roadways

Veterans Home of California at Chula Vista

2.2.10 Utility Access

Site utilities are critical to successful operations. Among the utilities or utility related components requiring site accesses are:

- Electrical service transformers
- Communications services
- Gas lines
- Stormwater management
- Water and sewer utility
- Oil service (if applicable)

- Emergency power (including fuel)
- Power and communications

Where possible, dual feeds for some utilities should be provided. The most pronounced of these would be power sources. An attempt should be made to attain a feed to the facility from different substations.

2.2.11 Services

Services as referred to in this section include, but are not limited to:

- Loading docks
- Shipping/receiving areas
- Morgue service areas
- Trash areas
- Vehicular turnaround roadways
- Service ramps

The services for Nursing Home facilities are a major component of day-to-day operations. The location of the services are not to conflict with the main entrance to the facility. (See Figure 2.10)



Figure 2.10

Site Service

State Veterans Home at Fitzsimons, Colorado

2.2.12 Landscaping (Natural & Designed)

1. *Natural Features*

Landscape features provide a major service to any site or campus. Natural features may include:

- Rock outcroppings
- Water features (lakes, streams, ponds, etc.)
- Trees
- Fields

Where possible, these features should be considered during the building and site design phases of the project. Just as a designer considers the topography during the planning phases, so should the natural aspects of a site be considered.

2. *Designed Features*

Designed features that relate to the site include:

- Trees
- Shrubs
- Grass
- Stone treatments
- Gardens
- Fountains
- Fences
- Plazas

While planning for the landscaping of the site, consider indigenous vegetation whether introduced or replaced because of the project. For special populations such as veterans and dementia residents, plants or shrubs that are free of risk due to accidental ingestion should be considered. Additional considerations include requirements of a shared site or other site-specific covenants that may affect the design.

2.2.13 Covered Entry

As part of the building and site design, provisions for a covered entrance at the primary access point to the facility are recommended. Provide enough covered area to accommodate two vehicles, one behind the other. The width of the roadway or motor court under the covering also should be designed to accommodate an accessible van to park at the entrance while allowing a vehicle to pass. It is not uncommon for emergency vehicles to access a Nursing Home site. Therefore, height of covered entrance is to be designed to allow clearance for large emergency vehicles.

The covered entrance is also an area where visitors and residents may relax and sit. Ample space should be planned and provided for seating and circulation near the entrance to the facility. (See Figure 2.11)



Figure 2.11

Covered Main Entrance

Nursing Home Care Unit at Loch Raven

2.3 Perception and Interiors

2.3.1 Introduction

The Nursing Home facility is considered a residential, “home-like” environment rather than a medical center. When designing interiors of the Nursing Home facility, include considerations for:

- Interior Finishes
- Colors
- Spatial Relationships
- Size of Spaces
- Exterior View
- Exterior Access

These are important aspects of the residential environment where individuals are indoors for extended periods of time. Designers should minimize travel distances between residents’ bedrooms, dining, recreation and lounge areas. Where shortened distances are not possible, provide handrails, and rest stops with convenient seating or other physical supports along an extended travel route.

2.3.2 Perception

Individual perception differs according to the social situation. In a Nursing Home facility, the creation of a home-like, healing environment can greatly improve the resident’s perception of their overall well being and sense of control over their environment. Perception is not based upon isolated responses to a particular stimulus, but rather as a reaction to the total stimulus field. When designing the interior of this building type, thought should be given as to how the proposed solution will be experienced by its user; for example:

- A dark border may be perceived as a drop-off and should be avoided.
- A toilet in stark contrast to the floor is perceived as a separate entity rather than a large field of a single surface.

Perception of space is based upon the use of cues that normally associates distance in our daily life. Many of these cues are developed at an early age in life and typically do not change as an individual ages. Examples of perception and relationships include:

- Familiar behavioral settings
 - Lounge Area
 - Living Room
- Sociopetal space and furniture
 - Clustered seating
 - Newspaper and magazine racks
- Get-Away Spaces (See Figure 2.12)
 - Outdoor Nature settings
 - Benches and pathways near water or of feature in a courtyard or garden



Figure 2.12

Outdoor Gathering Space
CO State Veterans Home
Fitzsimons, CO

- Family Spaces
 - Room with fireplace
 - Home-like arrangements
- Intimate Spaces
 - Tables and chairs on a balcony
 - Benches with a view
- Views to Exterior
 - Large windowed walls
 - Indoor/Outdoor areas (balconies, screened porches)
- Enhancing self-esteem
- Maximized independence
- Staff competencies
- Welcoming relatives into the facility
- Involvement of local community
- Provision of Wayfinding and orientation
- Meaningful use of time

2.3.3 Design and Dementia Care

Dementia is a general term indicating changes to a cognitive function that result from a range of specific, usually progressive and irreversible disorders of the brain. The most common of these disorders is Alzheimer's disease. Symptoms related to Alzheimer's include:

- Short term memory loss
- Difficulty in spatial perception
- Difficulty planning activities
- Lower thresholds for stress
- Behavioral Impairment
- Wandering behaviors

Dementia residents may remain at the Nursing Home for extended periods. A design that reflects sensitivity to the needs of the dementia population at a Nursing Home will have a positive impact on the residential environment.

1. *General Design* - The acknowledgement of the critical, functional issues is the first step towards a proactive approach in designing for dementia care in a residential facility. There are certain principles to consider when designing for the accommodations of the dementia resident. Planning considerations include:

- Reinforcing personal identity

A unit that is designed for a dementia populace should serve to compensate for the effects of dementia and reinforce the skills and functions that remain.

These features include:

- Designing for a "Healing Environment".
- Inclusion of generic, familiar activities
- Safety features that are not imposing (wander guard)
- Safe outdoor space
- Use of physical objects rather than color for recognition
- Limited size in the unit
- Noise control
- Enhancements of visual access
- Signage and Way Finding tools or cues

2.3.4 Lighting

Regardless of one's age, lighting plays an important role in the ability to perceive and discriminate light, color, contrast and textures. As one ages, the capacity diminishes and items that were once clear to see now seem fuzzy or unrecognizable. An inability to accurately judge color in interior environments can result in disorientation, accidents, and reduced efficiency in completing tasks, overall discomfort or ill health. The following sub-sections relate to the natural and artificial lighting considerations for the design of a Nursing Home facility:

1. Natural Light (Daylighting)

Daylight is the standard against which the human mind measures all things seen. Colors seen with daylight will appear real and appropriate through color constancy. The color produced by daylight will vary from dawn, to noon, to dusk. Color reflection from adjacent surfaces will vary as well. Strategies and elements of daylighting should be included in design. (See Figure 2.13) Daylighting is not an afterthought or a simple matter of applying some shading controls to the windows. Many factors are involved with the use of daylight in buildings:

- Aesthetics
- Psychological response
- Health
- Energy/Cost
- Percentage of window area
- Placement of window
- Orientation



Figure 2.13

Daylighting in a Resident Bedroom

Veterans Nursing Home

Fitzsimons, CO

Specific goals related to daylighting of buildings may be stated in simple terms:

- Design to achieve daylight in all feasible areas in significant, useful quantities.
- Distribute daylight reasonably uniformly, with no significant dark spots.
- Avoid allowing direct sunshine into the building interior in such a way that it may cause visual discomfort or visual disability. Assess the design for all possible sun penetration angles.
- Provide daylight sensitive controls for the electric lighting so that it will be dimmed or turned off when not needed.

2. Artificial Lighting

When measuring the effectiveness of artificial light, there are generally two scales by which this is done: the Color Rendering Index (CRI) and the Correlated Color Temperature (CCT). The CRI indicates how precisely a specific source of light can show an object in relationship to its true color. (See Table 2.2) The CCT describes the degree to which a color appears warm (reddish), neutral or cool (bluish) and is measured in degrees Kelvin (K). Well-saturated colors are best for environments used by the aging especially if color is being used as a directional tool or to enhance safety. (See Figure 2.14) An example would be the use of color to highlighting a change in floor level or designating an exit as the CCT of light sources has been found to increasingly influence color perception.



Figure 2.14

Use of Artificial Lighting in a Resident Bedroom

New York State Veterans Home

Montrose, NY

The following illustrations demonstrate the effects of artificial lighting on a plane of interest and the various solutions available:

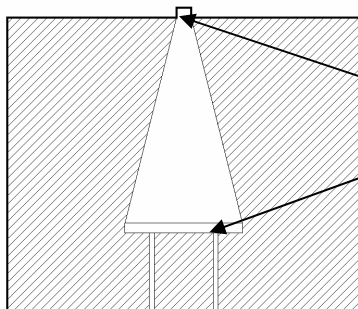

Figure 2.15

Overhead Downlighting – Low Intensity

Overhead Downlighting is effective for task-oriented activities such as those found in occupational therapy. This lighting technique will allow the individual to focus on that surface, either a table or a wall.

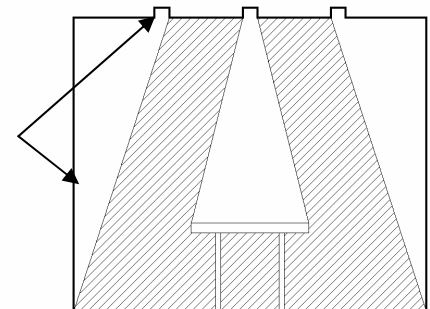

Figure 2.16

Overhead Downlighting with Lighted End Walls

This lighting technique allows a greater amount of illumination over a greater surface area.

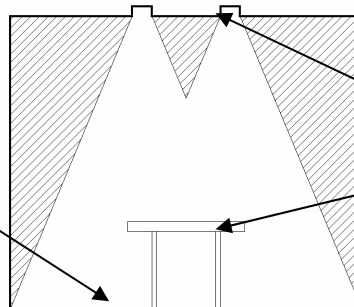

Figure 2.17

Overhead Diffuse – High Intensity

Overhead Diffuse lighting is effective in group activities such as dining and card playing.

Color Temperature (K)	Applications
2500	Bulk industrial and security lighting
2700 - 3000	Low light levels (10 fc); General residential lighting, hotels, fine dining and family restaurants, theme parks
2950 - 3500	Display lighting in retail and galleries; feature lighting
3500 - 4100	General lighting in offices, schools, stores, industry, medicine; display lighting; sports lighting
4100 - 5000	Special-application lighting where color discrimination is very important (uncommon for general lighting)
5000 - 7500	Special-application lighting where color discrimination is critical (uncommon for general lighting)
Minimum Lamp CRI	Applications
50	No critical industrial, storage, and security lighting
50 - 70	Industrial and general illumination where color is important.
70 - 79	Most office, retail, school, healthcare and recreational spaces.
80 - 89	Retail, work, and residential spaces where color quality is important
90 - 100	Retail and work spaces where color rendering is critical
Table 2.2 Color Classification Of Light Sources	

2.3.5 Contrast and Glare

The quality of lighting can be judged through two primary characteristics: contrast and glare. Contrast is necessary for good visual perception. It is also possible to produce excessive contrast, which impedes good visual response. Therefore, luminaires and light fixtures need some type of shielding device to prevent a direct view of the lamps.

Glare is usually associated with brightness differences or with reflected light. It is not recommended that luminaires be placed on the ceiling unless properly shielded with a lens, diffuser or shading device. Windows should generally be located to the resident's side to produce good quality task light without veiling reflections.

2.3.6 Physiological and Psychological Benefits

Interior design for Nursing Home facilities present a wide range of color problems due to the different needs of residents, visitors, doctors, nurses and other staff and the varied nature of specific spaces. The goal is to design a typical resident environment as a place where hospitality is the emphasis. During design, consider the following:

- Loss of balance
- Cognitive impairment
- Visual impairment
- Hearing impairment
- Increased sensitivity to temperature and direct sunlight.

Physiological and psychological design considerations include:

- Avoiding excessive direct natural light
- Providing visual flexibility such as adjustable lighting, blinds and shades;
- Introducing stimuli through lighting;
- Providing natural lighting;
- Using broad horizontal windows
- Avoid narrow vertical windows;
- Using 20 to 30% of the exterior wall as window area;
- Providing views with natural and synthetic elements.

2.3.7 Acoustics/Noise Control

If handled improperly, acoustical design in a Nursing Home facility can affect the resident's ability to hear and be heard. This may also cause the residents social discomfort, contributing to fear, embarrassment, depression, or isolation. Introduce sound absorption materials or

compartmentalization in the plan. The latter may afford an enhanced sense of privacy in the two bed room prototype.

Two types of noise that disrupt residents include:

- Sound from inside their rooms, such as a roommate snoring or listening to a loud television program,
- Sound generated from the outside, such as carts rolling down the hall.

2.3.8 Interior Finishes

Consider the following few key factors in the design process. These considerations have an impact on the built environment and the life cycle costs of the facility. The factors include:

- Maintenance,
- Durability,
- Affordability,
- Texture,
- Therapeutic attributes.

Additionally, designers should specify special coatings on fabrics and moisture resistant backings. Consider testing all product colors and textures for its perception and psychological impact within the Nursing Home environment. There are various aspects of an aging population that influence design of interior finishes and furniture selection. Examples include dementia and incontinence.

Creating a 'Healing Environment' that supports health is essential to quality patient care. (See figures 2.18 and 2.19) Factors that can assist in creating this environment include:

- Soft colors
- Warm finishes
- Music
- Healing gardens



Figure 2.18

Main Lobby Wall Aquarium
New York State Veterans Home
Montrose, NY



Figure 2.19

Front Lobby
Western Kentucky Veterans Center
Madisonville, KY

1. Floors

To minimize the number of falls and cushion them when they do occur, consider using continuous, slip resistant and resilient flooring materials, such as sheet rubber or vinyl with welded joints,

in resident toilet rooms and showers, in lieu of harder and sometimes uneven surfaces such as ceramic tiles with grouted joints. Carefully selected and appropriately specified carpeting materials used in lieu of harder surfaces may also minimize injuries due to falls in resident rooms and unit corridors, especially when recessed flush with adjacent flooring materials. Consider the following when choosing a flooring material in Nursing Home facilities:

- Readily cleanable surfaces
- Water resistance in food consumption and preparation areas
- Being physically unaffected by germicidal cleaning solutions.

Avoid or minimize slippery floor surfaces, area rugs, and abrupt changes in flooring materials without tapered thresholds or nosings. (See Figure 2.20) Reflective, glossy floors are to be avoided for a number of reasons. Beside the obvious fall hazard it presents, for those residents with vision degeneration diseases and depth perception issues, this finish can easily deceive the elderly population and cause unwanted behavioral and management problems. There are numerous low-luster resilient floorings available, with VCT (vinyl composite tile) being the preferred solution due to its cost and maintenance ease when replacement is necessary.

Consider carpet density when selecting it as a floor covering. Carpet density is the amount of pile yarn in unit volume of the carpet. This number translates into a "carpet traffic classification" which ranges from:

- I (light)

- II (Heavy)
- III (Extra Heavy)

The above classifications fluctuate according to use. In a Nursing Home environment, the resident room is considered Class II, while the staff station and corridors are considered Class III. The transition of finishes must be considered. (See Figure 2.20)



Figure 2.20

Finish Transition from Resident Area to Corridor

State Veterans Home at Fitzsimons, Aurora, CO

The following are the top 10 specified materials in the healthcare industry listed in order of preference. Refer to item 2.3.9 for specific benefits:

- VCT
- Sheet vinyl
- Broadloom carpet
- Vinyl-backed carpet
- Ceramic tile
- Carpet tile
- Vinyl plank flooring
- Linoleum
- Rubber flooring
- Poured flooring

Each of these products are viable choices, but consider these

recommendations when designing interiors:

- *Resident Rooms*
Sheet vinyl and VCT
- *Resident Bathrooms ; Tile to Carpet*
(See Figure 2.21)
Ceramic tile and sheet vinyl
- *Public Spaces (wall base)*
Rubber cove base, vinyl cove base, and stain grade wood base in oak, maple and cherry



Figure 2.21

Pattern and Surface Choices at Bathing Area

*US Soldiers and Airmen's Retirement Home
Washington, DC*

2. Walls

Walls are not seen only as a form of enclosure and privacy, but also as a form of support and guidance. The elderly often support themselves by holding onto the walls while performing their daily activities. Certain materials, textures, and colors should be encouraged while planning the interior design of the facility. Consider the following:

- *Resident Rooms (wall finishes)*
Water/latex-based paint, Type II vinyl wall covering, rigid vinyl sheet/corner guards, wall covering borders

- *Public Spaces (wall finishes)*
Type II vinyl wall covering, water/latex-based paint and rigid vinyl sheet and corner guards or Type I vinyl wall covering, plaster/sheet corner guards.

3. *Doors and Hardware*

Door hardware for this building type is unique because the residents include people who are aged, infirmed, sick or disabled. Nursing Home residents need to operate hardware with the least amount of effort.

4. *Ceiling Material and Height*

When choosing a ceiling material and height, consider the use of the space and the intended user. (See Table 2.3) The materials commonly specified are gypsum wallboard (GWB) and acoustical ceiling tile (ACT). In keeping with the common goal to present a healing, comfortable environment for the resident, painted gypsum board ceilings are recommended. If budget is a defining factor in ceiling selection, (ACT) may become the default solution.

Consider the following ceiling heights when designing for the residents of a Nursing Home facility:

Room/Space	Suggested Minimum Heights
Resident Room	9'-0"
Corridors	9'-0"
Activity Areas	10'-0"
Dining	10'-0"
Resident Toilet/Showers	8'-0"

**Table 2.3
Recommended Ceiling Heights**

2. *Seating Patterns and Fabric*

The following materials are the recommended choices for Nursing Home care environments:

- Woven Crypton,
- Vinyl
- Solution-dyed fabrics

Refer to Figure 2.22 for pattern examples of resident bedroom armchairs, and Figure 2.23 for resident dining room seating.



Figure 2.22

Examples of Resident Bedroom Seating
(Arm type chairs are good for NHCUs)



Figure 2.23

Examples of Resident Dining Seating

2.3.9 Characteristics of Floor Finishes

Due to the long term nature of the Nursing Home facility, finish selections play important role in establishing a "home-like" setting. While aesthetics are significant, maintenance also must be taken into consideration. The finish types that follow illustrate some of the characteristics to consider when planning the interior designs and furnishings for a Nursing Home facility.

1. *Carpet*
 - Aesthetically pleasing
 - Durable
 - Ease of maintenance
 - Wheelchair access
 - Acoustics
 - Availability of vinyl backing to provide moisture resistance
2. *Sheet Vinyl Flooring*
 - Infection control
 - Aesthetics
 - Moisture barrier
 - Usually complies with health department regulations
3. *Vinyl Composite Tile (VCT)*
 - Low Initial cost
 - Durability
4. *Vinyl Wall covering*
 - Aesthetics
 - Durability
 - Wheelchair access
 - Infection control
5. *Water-based Paint*
 - Indoor air quality (IAQ)
 - Less off-gassing

6. *Woven Cryton*
 - Durability
 - Aesthetics
 - Infection control
 - Moisture barrier
 - Readily available product
7. *Vinyl Upholstery*
 - Durability
 - Ease of maintenance
 - Infection control
 - Moisture-proof
 - Bleach-resistant

2.3.10 Color & Texture Selection

Nursing Home design should consider colors and hues. The principal hues are composed of three distinct palettes - warm, cool and neutral.

1. *Warm*

Warm colors are generally associated with physical warmth and the resultant sense of contentment. Warm colors can be used where large windows symbolize sunrise and sunset as features in common areas. Hues on the warm side of the color circle (red, orange, and yellow) and their related tints and shades are generally understood as comfortable, cozy, homelike, and pleasant. Interiors with primarily warm color schemes may prove comfortable to occupants with actual air temperatures lower than required to achieve similar comfort in identical spaces using cooler colors.

2. *Neutral*

Neutral colors, depicted by white, black, gray and chromatic colors are desaturated with a high content of neutrals. They fall between warm and cool colors, so they have a less psychological effect on its users – often referred to being “boring” or “bland”.

Neutral colors offer no emotional stimulation or response and should not be used in areas where activity and or group responses are desired.

3. Cool

Cool colors are not associated with calm, relaxing experiences, as the name would indicate. These colors tend to lower the sense of actual air temperature and so are often preferred in situations where excessive heat is anticipated. In terms of interior design, cool colors can often cause depressive and negative behavior.

Colors that suggest comfort and a somewhat home like atmosphere can ease the difficulties and enhance the quality of life in a Nursing Home facility. Color preferences of elderly residents tend to be conservative so that warm paint colors, wood tones and conservative patterns in carpet and drapery are recommended. (See Figures 2.24 and 2.25.)



Figure 2.24

Resident Dining Area
State Veterans Home at Fitzsimons
Aurora, CO



Figure 2.25

Resident Semi-Private Bedroom
State Veterans Home at Fitzsimons
Aurora, CO

2.3.11 Wayfinding & Signage

Orientation to and throughout any facility is important. In the case of a Nursing Home, it tends to be of an elevated importance. Disorientation of a Nursing Home resident can be a traumatic experience. To mitigate this occurrence, clear, attractive signage with large contrasting notations is required. (See Figures 2.26.)

Color coding bedrooms and common areas are also helpful tools for the residents when trying to find their way around. In addition, placing a recognizable photograph of a loved one or the resident himself or herself on the residents' bedroom door, aids in wayfinding.

In terms of signage, designers should understand the effects of hue, saturation, and brightness on "attention getting" as they select color schemes.



Figure 2.26

Wayfinding Signage in Corridors
State Veterans Home at Fitzsimons
Aurora, CO

Lighting can be used to identify settings as well as to provide visual acuity. Definition in rooms, adjoining spaces and corridors can be accomplished by planned placement of various types of lighting fixtures. Chandeliers, pendants, table lamps, floor lamps and sconces can all be used to identify spatial relationships, as well as to define usage within a room or area. (See Figure 2.27) Dining alcoves may use pendant fixtures for table placements. Corridors may combine sconces and pendants to accentuate an intersection or feature. Table and floor lamps can serve as symbols of "home-like" settings.



Figure 2.27

Ceiling Pendant
Baltimore Rehabilitation and Extended Care
Center
Baltimore, MD

2.4 Systems Criteria

2.4.1 Heating, Ventilating and Air Conditioning (HVAC)

1. General

The HVAC system should comply with the most current version of Department of Veterans Affairs (VA) HVAC Design Manuals, VA Design and Construction Procedures, VA Master Construction Specifications and VA Standard Details, where applicable. Deviations from the VA guidelines may be made provided approval is obtained from the VA. Where specific VA requirements are not available or indicated in this document, design criteria from industry standards such as ASHRAE, NFPA, and DOE etc. should be submitted to the VA for review and approval.

2. Energy Economic Analysis

The HVAC system should be selected based on an economic analysis performed in compliance with Public Law 95-619 to determine the most cost effective system for the building over a 20-year life cycle.

3. Energy Conservation

Energy conservation should be emphasized in all aspects of the building design. The building should meet the requirements of the most current version of ASHRAE Standard 90.1 and the DOE regulations. These energy standards apply to HVAC systems as well as the building envelope, service water heating, lighting and energy management. Certification should be provided to the VA that the building is designed in compliance with the applicable energy conservation provisions.

4. Exterior Design Conditions

Exterior design conditions should be based on the most current edition of the ASHRAE Fundamentals Handbook. Summer design conditions should be based on the 0.4 percent dry bulb and wet bulb temperatures indicated under "Cooling db/mwb". Where cooling towers are applicable, select the cooling tower based on the wet bulb temperature indicated under "Evaporation wb/mdb". Winter design conditions should be based on the 99.6 percent dry bulb temperature indicated under "Heating dry bulb". The A/E may recommend more severe outdoor climatic conditions for review and approval by the VA.

5. Indoor Design Conditions

Indoor design conditions for each space should be maintained throughout the year. Interior design conditions for all spaces should be maintained in accordance with the most current version of ASHRAE Standard 55. In addition, the conditions shown in Table 2.4 should be maintained.

6. Supply Air Requirements

The supply air volume should be established to meet the cooling load requirements of the occupied space. The supply volume should, however, be modified to meet a) minimum air change requirements, or b) maintain proper space pressurization relative to room exhaust requirements. For all air systems, the supply air minimum airflows shall be established to maintain the minimum air change rates. See Table 2.5. In addition, filtration shall be comprised of a minimum 30% efficient pre-filter and 85% efficient after-filters, where filter efficiencies shall be based

on the most current version of ASHRAE Standard 52.

7. Outdoor Air Requirements

The HVAC design should provide each space with not less than the minimum recommended quantity of ventilation air as indicated in the most current version of ASHRAE Standard 62. In addition to the ASHRAE Standard 62 requirements, the minimum air changes of outside air shown in Table 2.6 should be required.

8. Exhaust Air Requirements

The HVAC design should provide exhaust air to spaces to control the transfer of odors and provide proper room pressurization. At a minimum, exhaust air and pressurization should be provided as shown in Table 2.7

9. Noise Criteria

The HVAC design should provide resulting sound levels in occupied spaces not to exceed the levels shown on Table 2.8 in all octave bands.

10. Seismic Requirements

Where applicable, earthquake resistive design should comply with the most current version of VA Handbook H-18-8, Seismic Design Requirements and the Uniform Building Code. Seismic design also should conform to the most current versions of SMACNA and NUSIG guidelines.

11. Design Features

Economizer: Air conditioning systems should be designed to operate below 48 degrees F (9 degrees C) outdoor air temperature without refrigeration.
Perimeter heat: Provide perimeter heat for bedrooms and other perimeter spaces when the outdoor winter design

temperature is 9 degrees F (-12 degrees C) or lower than interior temperature.

Emergency Power: Emergency power should be provided for, but not limited to, the following equipment/systems:

- All heating water system components (pumps, condensate return pumps, boilers, etc.) where outdoor design conditions are below 20 degrees F (-6 degrees C)
- Automatic temperature control system and components
- Exhaust system serving the isolation suite

12. Temperature Control Criteria

General: The automatic temperature controls should be direct digital control (DDC) with electric or pneumatic actuation of valves, dampers, terminal units, etc. A dedicated standalone building management system (BMS) or engineering control center (ECC) should be provided. The ECC should be capable of being connected to an existing or future ECC at the medical center, if applicable. Final selection of the control system options (pneumatic vs. electric, standalone or tied into existing ECC, etc.) should be reviewed and approved by the VA prior to proceeding with the design of the temperature control system.

Room Temperature Control: Individual room controls should be provided for, but not limited to, the following spaces: one / two bedrooms, anterooms, conference rooms, director's office and corridors. In addition, not more than four interior rooms of similar function should be grouped to one control zone, nor should interior and exterior spaces be grouped on a common zone.

2.4.2 Plumbing

1. General

The plumbing and medical gas systems should comply with the current version of Department of Veterans Affairs (VA) Plumbing Design Manuals, VA Design and Construction Procedures, VA Master Construction Specifications and VA Standard Details, where applicable. Deviations from the VA guidelines may be made provided approval is obtained from the VA. In addition, the design should meet the requirements of the current version of the National Standard Plumbing Code (NSPC) and the National Fire Protection Association (NFPA). Where state or local codes are more stringent than the above requirements, submit criteria to the VA for review and approval.

2. Domestic Water Systems

Water service should be extended to the building to serve the domestic and fire protection systems. Domestic water should be distributed to the plumbing fixtures and equipment. The system should maintain a maximum velocity and pressure in accordance with the National Standard Plumbing Code and provide water hammer arrestors in accordance with ASSE 1010 for sealed wall installations without access panels. Size and locate arrestors per the Plumbing Drainage Institute (PDI). Provide wall hydrants on each exterior wall, not to exceed 200 feet (60 m) apart.

A domestic booster pump system should be provided where street pressure is inadequate. Domestic booster system should include three pumps. One pump should be sized for one-third the total demand and the two

remaining pumps should be sized for two-thirds of the total demand. Provide alternating control for the pumps as well as a pressurized storage tank. Emergency power should be provided for the domestic booster system.

Provide duplex shell and steam coil central water heaters with the capacity of generating the flow demand at 140 degrees F (60 degrees C) with each heater sized to supply 75% of the demand. The heater discharge temperature, however, should be set for 130 degrees F (54 degrees C). A hot water re-circulating system should be provided. The domestic heating water system also should be in accordance with the requirements of the most current version of ASHRAE Standard 90.1.

3. Plumbing Fixtures

Plumbing fixture types and flow restrictors should be in accordance with the current version of the National Standard Plumbing Code. In addition, plumbing fixtures, where required, should comply with the current version of the American with Disabilities Act (ADA) and as per state and Federal requirements.

4. Sanitary and Storm Drainage Systems

Provide an adequate number of sanitary and storm drainage connections from the building. Provide a minimum of two connections from each building with a maximum sanitary sewer size of 12-inch (300 mm). One sanitary connection may be provided if the connection size is six-inch (150 mm) or less. Maximum allowable storm drain size is 15-inch (375 mm). Sizing should be based on

the most current version of the National Standard Plumbing Code.

Kitchen waste, where applicable, should be provided with a grease removal system.

5. *Medical Gas and Vacuum Systems*

Medical compressed air, oxygen and medical vacuum systems should be provided in accordance with the most current versions of NFPA 50 and 99 and the Compressed Gas Association Standards. Air, oxygen and vacuum requirements may range from 10 to 100% of the beds. Coordinate project specific requirements with the VA.

6. *Seismic Requirements*

Where applicable, earthquake resistive design should comply with the most current version of VA Handbook H-18-8, Seismic Design Requirements and the IBC. Seismic design also should conform to the most current versions of SMACNA and NUSIG guidelines.

2.4.3 Electrical

1. *Electrical Closets*

Provide separate electrical closets with clearances in accordance with the requirements of the National Electrical Code (NEC). In buildings having multiple floors, stack closets.

2. *Public Utility Requirements*

Contact servicing agencies and comply with their requirements for electric services. Make necessary submittals to utility companies for approval of equipment to be installed.

3. *Seismic Restraints*

Requirements should be as specified by local codes and ordinances. Work shall

comply with detailed provisions made by local authorities having plan check and inspection jurisdiction.

4. *Electrical System Characteristics*

Contact the local electric utility company for the type and availability of service. When possible, multiple utility feeders from separate utility substations should be provided for service redundancy. Three phase, 480/277 volt or 208/120 volt secondary systems are acceptable. A utility owned, pad mounted transformer is preferred for these services. Service entrance equipment should comply with the VA Electrical Design Manual.

5. *Emergency Power*

An emergency generator should be provided as an electrical source for power and lighting during an interruption of the normal electric supply. Where stored fuel is required, storage capacity should permit continuous operation for at least 24 hours. The specific loads and branch circuit arrangement should comply with NEC Article 517 as well as the VA Electrical Design Manual Chapter 4.

6. *Lighting*

Comply with the Illuminating Engineering Society (IES) recommended lighting levels. Resident rooms should utilize natural light as much as possible. In addition, general lighting and night lighting are required. A reading light should be provided for each resident. Reading light controls should be readily accessible to residents. At least one night light fixture in each resident room should be controlled at the room entrance. All light controls in resident areas should be

silent. Lighting should comply with the VA Electrical Design Manual Chapter 6.

7. Receptacles

Provide each resident room with duplex-grounded receptacles. Provide one at each side of the head of each bed and one on every other wall. Electrical receptacle cover plates or electrical supplied from the emergency system should be distinctively colored or marked for identification. Ground fault interrupters should comply with NFPA 70. Receptacles should comply with the VA Electrical Design Manual Chapter 3.

8. Conduits

Conduits should be rigid where used in damp or exposed locations, or where specifically required by the NEC. PVC conduits should be used where routed underground. Electrical metallic tubing should be used in dry concealed locations and furred ceiling spaces. Flexible conduits should be used for final connections to recessed lighting fixtures, to motor driven equipment and vibrating equipment. PVC Schedule 40 conduits should be used for concrete encased feeders. PVC Schedule 80 conduits should be used for direct buried branch circuits. Conduit should not be used as a ground path; all electrical circuits should contain a ground wire. Minimum conduit size should be 0.5 inches [13 mm].

9. Conductors

Provide copper conductors with 600-volt insulation for low voltage distribution.

Conductors No. 8 and larger should be stranded, type THWN. Smaller conductors should be a solid type THHN/THWN. Aluminum conductors are not permitted. Conductors for use in high temperature locations should be insulated as required by the NEC. Minimum size of power conductors should be No. 12.

10. Nurse Call System

Provide a nurse call system. Provide each bed location with a call device. An emergency call system should be provided at each resident toilet, bath, and shower room. This system should be accessible to a resident lying on the floor. Design the emergency call system so that a call activated by a resident will initiate a signal distinct from the regular staff call system and that can be turned off only at the resident's location. The signal should activate an annunciator panel at the staff work area or other appropriate location, and either a visual signal in the corridor or at the resident's door.

Wireless technologies for staff should be studied along with hard wired or integrated systems, to meet the needs of individual facilities.

11. Fire Alarm System

Provide fire alarm and detection systems in compliance with NFPA 101 and NFPA 72 as well as VA Fire Protection Design Manual.

2.4.4 Reference Tables

<u>Room or Area</u>	<u>Summer</u>		<u>Winter</u>	
	<u>db (°F)</u>	<u>max RH %</u>	<u>db (°F)</u>	<u>min RH %</u>
One / Two Bed Rooms	76	50	78	30
Ante Rooms	76	50	78	30
Dining Room	78	50	72	30
Lounges	78	50	72	30
Bathrooms & Toilet Rooms	78	--	72	--
Offices / Conference Rooms	78	50	72	30
All other occupied spaces	78	50	72	30

Table 2.4

INDOOR DESIGN CONDITIONS

<u>Room or Area</u>	<u>Minimum Design Supply Air Changes per Hour</u>
One / Two Bed Rooms	4
Ante Room	12
Dining	10
Smoking Room	12
Corridors	4

Table 2.5

SUPPLY AIR REQUIREMENTS

** See CDC criteria as higher air change rates may be required to meet the intent of the CDC requirements dependent upon HVAC distribution methodology.

<u>Room or Area</u>	<u>Minimum Air Changes per Hour of Outside Air</u>
One / Two Bed Rooms	2
Offices	1

Table 2.6

OUTDOOR AIR REQUIREMENTS

<u>Room or Area</u>	<u>Room Pressure</u>	<u>Minimum Exhaust Air Changes per Hour</u>
Bathing Facilities	Negative	10
Bathrooms & Toilet Rooms	Negative	10
Clean Utility	Positive	Supply air minus 15%
Locker Rooms	Negative	Supply air plus 15%
Soiled Linen / Utility	Negative	6
Storage Rooms (soiled or dirty)	Negative	Supply air plus 15%

Table 2.7

EXHAUST AIR REQUIREMENTS

<u>Room or Area</u>	<u>Maximum NC Level</u>
One / Two Bed Rooms	35
Bathrooms & Toilet Rooms	40
Dining	45
Offices, Lobbies, Waiting Areas	35

Table 2.8

NOISE CRITERIA

Page Left Intentionally Blank



2.5 Guide Plates, Reflected Ceiling Plans and Data Sheets

Architectural Notes

Applicable Codes and Standards: See 2.1 Codes and Standards.

1. All new construction and all renovated sleeping areas shall be fully protected by an automatic sprinkler system. Project-specific conditions may apply that require sprinklering of renovation in non-sleeping areas as well.
2. The data sheets, which accompany each guideplate, list equipment in the following format:

	QUANTITY	AI	DESCRIPTION

Table 2.5.1

The legend for the Equipment Tables is as follows:

QUANTITY - Quantity of equipment in Long Term Care Nursing Units.

AI - Acquisition/Installation

vv – VA furnished and VA installed

vc – VA furnished and Contractor installed

cc – Contractor furnished and Contractor installed

cv – Contractor furnished and Contractor installed

Note: The above may vary from project to project

DESCRIPTION – Detailed specification of equipment.

3. When producing architectural drawings for the VA, designers should follow Standard Detail 00000-1.DWG (PG-18-4) which outlines the accepted symbols for designating equipment with regard to accountability as to procurement and installation responsibilities.
4. Provide reinforcement behind automatic door push plates.

Hardware Schedule

All locks and latch sets in the long-term care facility are to have lever handles. Hardware sets correspond to VA Master Construction Specifications, Section 08710, Builder's Hardware, except as noted*. Refer to Section 08721 for Automatic Door Operators.

HW 4

Butts as required
Door Pull
Push Plate
Closer C02011
Armor Plate
Holder C22511

HW 6

Butts as required
Door Pulls
Push Plates
Combination Closer / Holder

HW 7

Butts as required
Latch F01 or F75

HW 13

Butts as required
Lock F07 or F86

HW 14

Butts as required
Lock F02 or F76
Provide Emergency Key
Provide turn piece on
both sides of lock

HW 23

Butts as required
Lock F04 or F81

HW 43

Butts as required
Lock F07 and F86
Closer C02051

HW 45

Butts as required
Lock F04 or F81
Closer C02011

HW 52

Butts as required
Latch F04 or F81

HW 69

Butts as required
Lock F17 or E16071
Door Pull
Push/Pull plate J300
Closer C02051
Armor Plate



HW 126

Butts as required
Lock F17 or E16071
2 Flush Bolts Top / Bot
2 Push Pull Plates J300
2 Door – pulls
2 Armor Plates

Abbreviations

A	Amps
AC	Air Condition
A.F.F.	Above Finished Floor
AF	After Filter
AI	Acquisition and Installation
AR	As Required
CF	Construction Funds, Department of Veterans Affairs Furnished, Installed by VA or Contractor
CC	Contractor Furnished and Installed, Construction Funds
CT	Corrective Therapy
CPU	Central Processing Unit
CRS	Corrosion-Resisting Steel
DISP	Dispenser
ES	Equipment Symbol
FC	Foot Candle
FPS	Fire Protection System
MCS	Master Construction Specifications
MIN	Minimum
NFPA	National Fire Protection Association
NSF	Net Square Feet
PF	Pre-Filter
PBPU	Patient Bedside Power Unit
RB	Rubber Base
RH	Relative Humidity
PT	Physical Therapy
OT	Occupational Therapy
SD	Standard Detail, see PG-18-4
SS	Stainless Steel
TPD	Toilet Paper Dispenser
TYP	Typical
VC	Department of Veterans Affairs Furnished Contractor Installed, Medical Care Funds for Purchase, Construction Funds for Installation
VV	Department of Veterans Affairs Furnished and Installed, Medical Care Funds
W	Watts
V	Volts

Legend of Symbols

	GROUND FAULT INTERRUPTOR		NURSE CALL STAFF STATION
	JUNCTION BOX		NURSE CALL DOME LIGHT
	HUMIDISTAT		FIRE EXTINGUISHER
	THERMOSTAT		FIRE ALARM/MANUAL PULL STATION
	NIGHT LIGHT		FIRE ALARM/AUDIO-VISUAL DEVICE
	NURSE CALL EMERGENCY STATION		HOSPITAL RADIO TUNER/ VOLUME CONTROL
	NURSE CALL EMERGENCY STATION		VACUUM OUTLET *
	NURSE CALL DUTY STATION		TELEVISION CABLE OUTLET
	SPEAKER		DUPLEX RECEPTICLE
	INCANDESCENT LIGHT FIXTURE		QUADRAPLEX RECEPTICLE
	1 X 4 FLUORESCENT FIXTURE		SINGLE POLE SWITCH
	2' x 4' FLUORESCENT LIGHT FIXTURE		THREE WAY SWITCH
	HVAC SUPPLY		BUILDING SECTION
	HVAC RETURN		FLOOR MOUNTED RECEPTACLE
	TELEPHONE JACK		
	EXIT LIGHT		
	SMOKE DETECTOR		

Resident Room Module Equipment

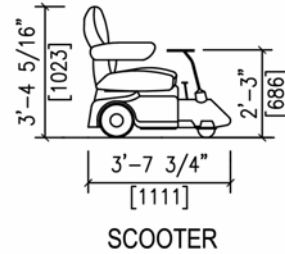
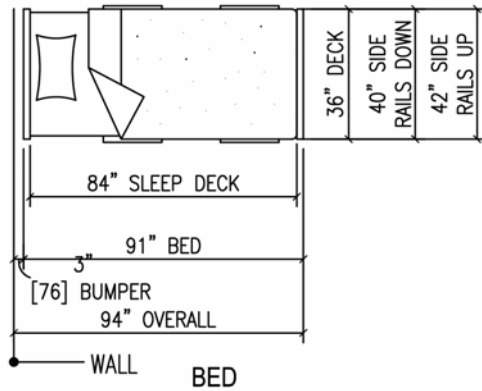
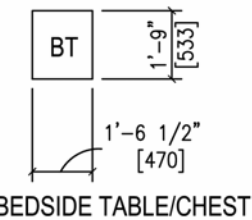
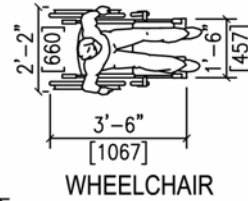
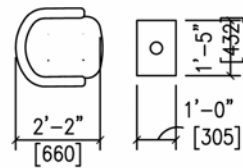
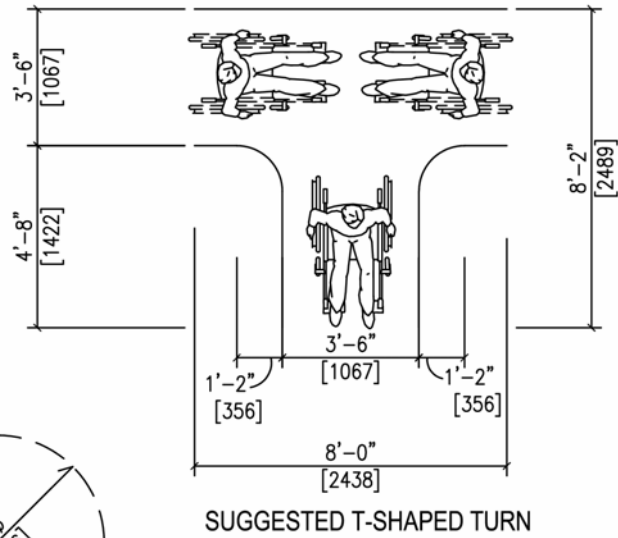
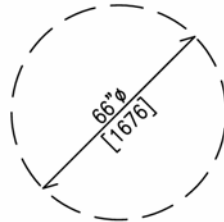
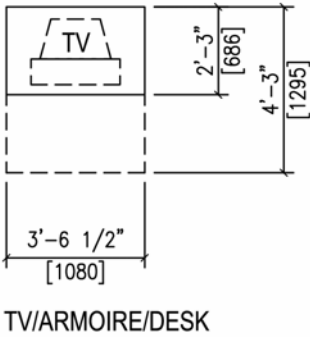
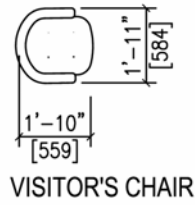
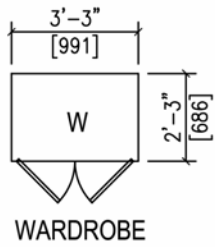

1. One Bed Room - 175 NSF [16.26 m²]

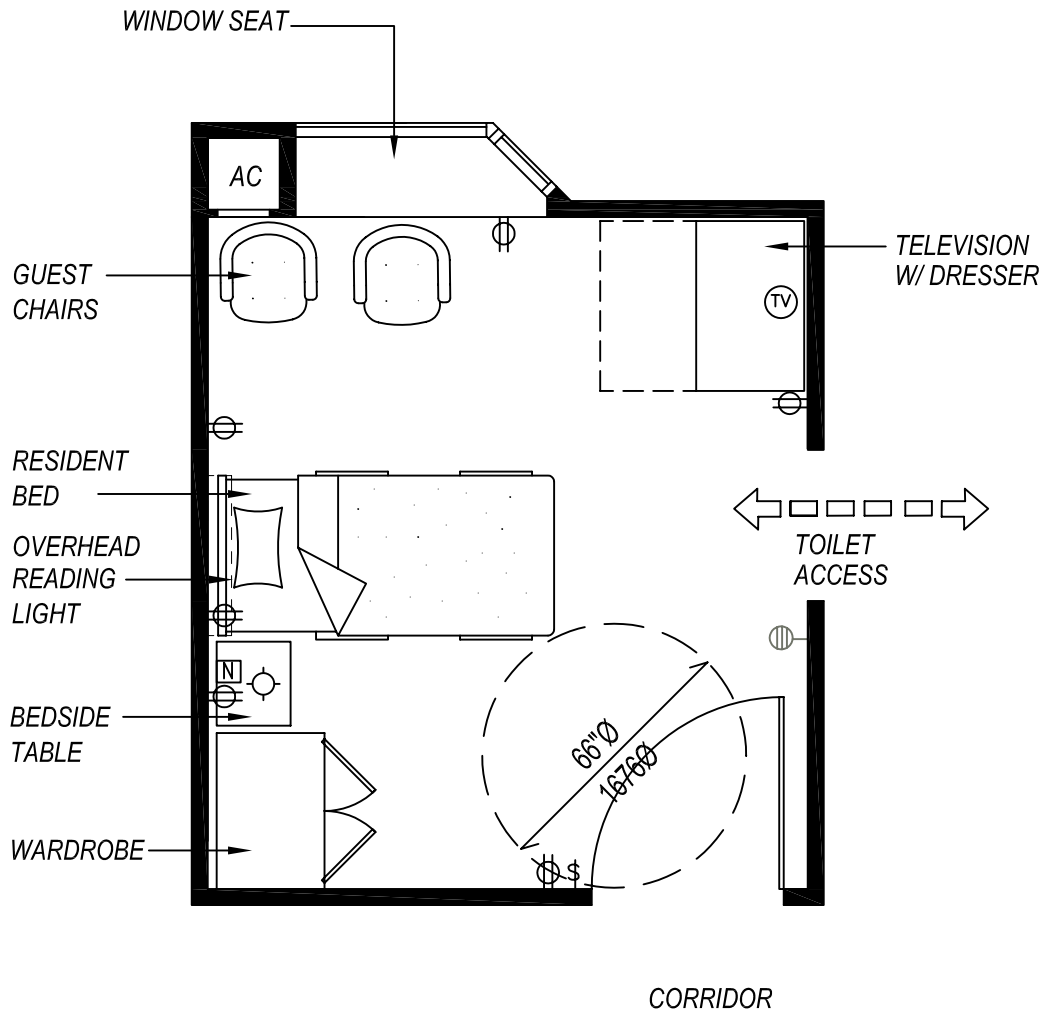
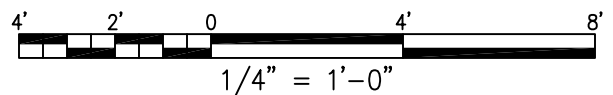

Figure 2.5.1

It may be helpful for the designer to review information in Part 3 - Planning and Design Data for dimensional and planning contextual data.



1. One Bed Room Reflected Ceiling Plan

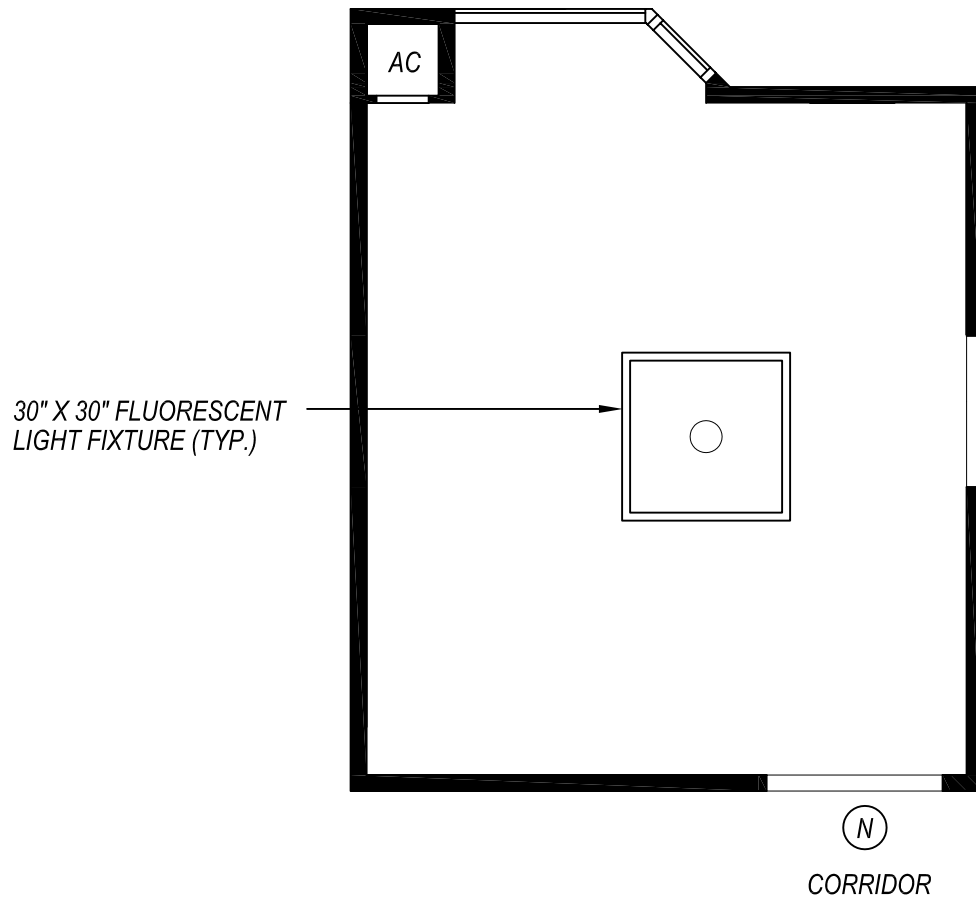
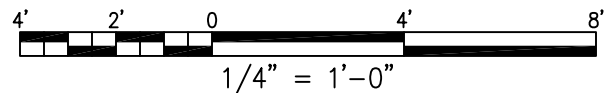

Figure 2.5.2

It may be helpful for the designer to review information in Part 3 - Planning and Design Data for dimensional and planning contextual data.



1. One Bed Room

Function:

The resident room is both an environment for living and a major setting for care. It is typically viewed as one of several "behavior settings" that the resident will occupy each day. It is more than a "bedroom." In Long Term Care, it provides features that support care and routines of daily living.

Space Requirement:

175 NSF [16.26 m²]

Architectural:

Finish Code:	1-A
Floor Finish:	Vinyl Composition Tile
Base:	RB
Wall Finish:	Gypsum Wallboard*
Ceiling:	Acoustical Tile
Ceiling Height:	9'-0" (8' w/wall-mount TV)
Noise (STC Rating):	
Slab Depression:	None
Special Construction:	-
Hardware:	7
Doors:	4'-0" x 7'-0" wood or metal, optional view glass panel.
Windows:	Required by code, operable, see PG-18-3, Topic 1, Codes and Standards.

*Vinyl Wallcovering at Lavatory

HVAC:

Temperature/Humidity:	
Summer:	76° F, Max. 50% RH
Winter:	78° F, Min. 30% RH
Min. Air Changes/Hour:	4 AC/H
Min. % Outside Air:	2 AC/H
Pressure:	-
Noise Criteria:	Max. 35 NC

Electrical:

Lighting Levels:	
Gen. Illum:	10fc
Task Illum:	30fc
Over Bed:	N/A
Emergency	
Egress:	N/A
Emergency Power:	
Medical Gases:	N/A
Night Lights:	Y
Vanity Light:	N/A
One Receptacle	
per PBPU:	N/A
Nurse Call:	Y

1. One Bed Room

Equipment Table:

SYMBOL	QUANTITY	AI	DESCRIPTION
	1		BED, ELECTRIC, 120 VOLT, 20 AMP, 1067 mm X 2134 mm (42" X 84"), WITH 76 mm (3") BUMPER GUARD
	1		MATTRESS, BED
	1		STAND, NIGHT, WITH TOWEL BAR, 470 mm X 464 mm X 876 mm (18-1/2" X 19" X 34-1/2")
	2		CHAIR, LOUNGE TYPE, GERIATRIC, 635 mm X 991 mm (25" X 39")
	AR		RECEPTACLE, ELECTRICAL, DUPLEX, 120 VOLT, 20 AMP, FOR POWER OPERATED BED ON WALL AT HEAD OF BED
	1		LIGHT, NIGHT
	AR		FIXTURE, LIGHTING, FLUORESCENT, FOR GENERAL ILLUMINATION AND READING LIGHT ON HEAD WALL OVER EACH BED, WITH QUIET SWITCH ON FIXTURE WITHIN REACH OF PATIENT IN BED BY PULL CORD SWITCH
	1		NURSE CALL, PANEL WITH CORRIDOR SIGNAL LIGHT
	1		WARDROBE, WITH SHELF AND HANGER ROD
	1		DRESSER, 3 DRAWER
	AR		RECEPTACLE, ELECTRICAL, DUPLEX, 120 VOLT, 20 AMP, ON WALL, ONE EACH SIDE OF BED
	1		TELEVISION

TABLE 2.5.1
One Bed Room

2. Two Bed Room - 390 NSF [36.23 m²]

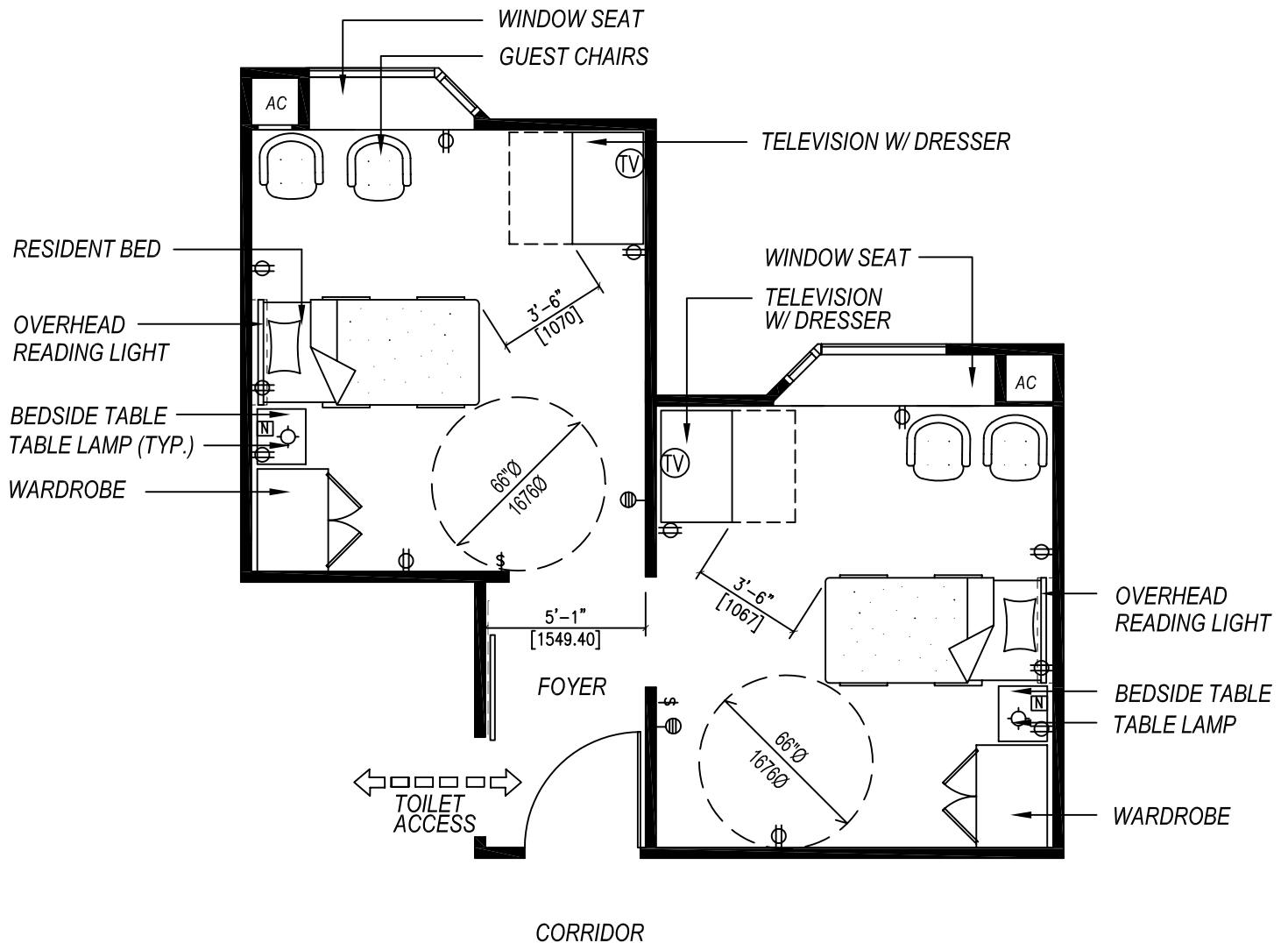
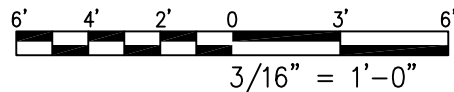

Figure 2.5.3

It may be helpful for the designer to review information in Part 3 - Planning and Design Data for dimensional and planning contextual data.



2. Two Bed Room Reflected Ceiling Plan

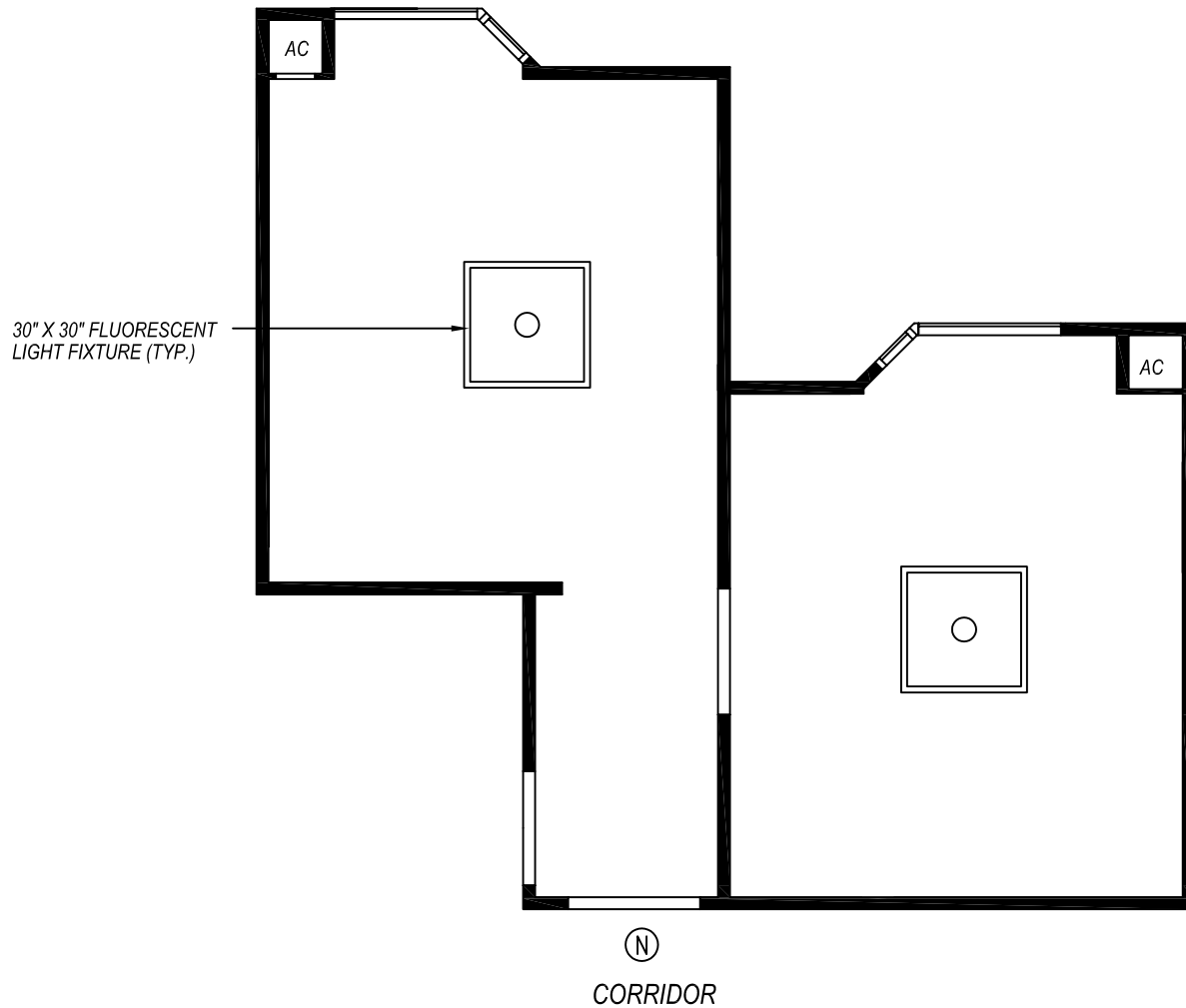
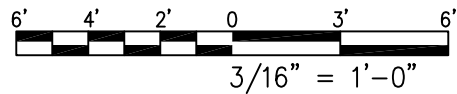

Figure 2.5.4

It may be helpful for the designer to review information in Part 3 - Planning and Design Data for dimensional and planning contextual data.



2. Two Bed Room

Function:

This space is intended to accommodate two residents sharing a toilet room. The resident room is both an environment for living and a major setting for care. It is typically viewed as one of several "behavior settings" that the resident will occupy each day. It is more than a "bedroom." It provides features that support care and routines of daily living. It is used by two residents with similar care needs.

Space Requirement:

390 NSF [36.23 m²]

Architectural:

Finish Code:	1A
Floor Finish:	Vinyl Composition Tile
Base:	Vinyl
Wall Finish:	Gypsum Wallboard*
Ceiling:	Acoustical Tile
Ceiling Height:	9'-0" (8' w/wall-mount TV)
Noise (STC Rating):	35
Slab Depression:	None
Special Construction:	-
Hardware:	7
Doors:	4'-0" x 7'-0" wood or metal, optional view glass panel.
Windows:	Optional sliding door into toilet.

*Vinyl Wallcovering at Lavatory

HVAC:

Temperature/Humidity:	
Summer:	76° F, Max. 50% RH
Winter:	78° F, Min. 30% RH
Min. Air Changes/Hour:	4 AC/H
Min. % Outside Air:	2 AC/H
Pressure:	-
Noise Criteria:	Max. 35 NC

Electrical:

Lighting Levels:	
Gen. Illum:	10fc
Task Illum:	30fc
Over Bed:	N/A
Emergency	
Egress:	N/A
Emergency Power:	
Medical Gasses:	N/A
Night Lights:	Y
Vanity Light:	N/A
One Receptacle	
per PBPU:	N/A
Nurse Call:	Y

2. Two Bed Room

Equipment Table:

SYMBOL	QUANTITY	AI	DESCRIPTION
	2		BED, ELECTRIC, 120 VOLT, 20 AMP, 1067 mm X 2134 mm (42" X 84"), WITH 76 mm (3") BUMPER GUARD
	2		MATTRESS, BED
	2		STAND, NIGHT, WITH TOWEL BAR, 470 mm X 464 mm X 876 mm (18-1/2" X 19" X 34-1/2")
	4		CHAIR, LOUNGE TYPE, GERIATRIC, 635 mm X 991 mm (25" X 39")
	AR		RECEPTACLE, ELECTRICAL, DUPLEX, 120 VOLT, 20 AMP, FOR POWER OPERATED BED ON WALL AT HEAD OF BED
	2		LIGHT, NIGHT
	AR		FIXTURE, LIGHTING, FLUORESCENT, FOR GENERAL ILLUMINATION AND READING LIGHT ON HEAD WALL OVER EACH BED, WITH QUIET SWITCH ON FIXTURE WITHIN REACH OF PATIENT IN BED BY PULL CORD SWITCH
	2		NURSE CALL, PANEL WITH CORRIDOR SIGNAL LIGHT
	2		WARDROBE, WITH SHELF AND HANGER ROD
	2		DRESSER, 3 DRAWER
	AR		RECEPTACLE, ELECTRICAL, DUPLEX, 120 VOLT, 20 AMP, ON WALL, ONE EACH SIDE OF BED
	2		TELEVISION

TABLE 2.5.2
Two Bed Room

3. Special Care Resident Room - 320 NSF [29.72 m²]

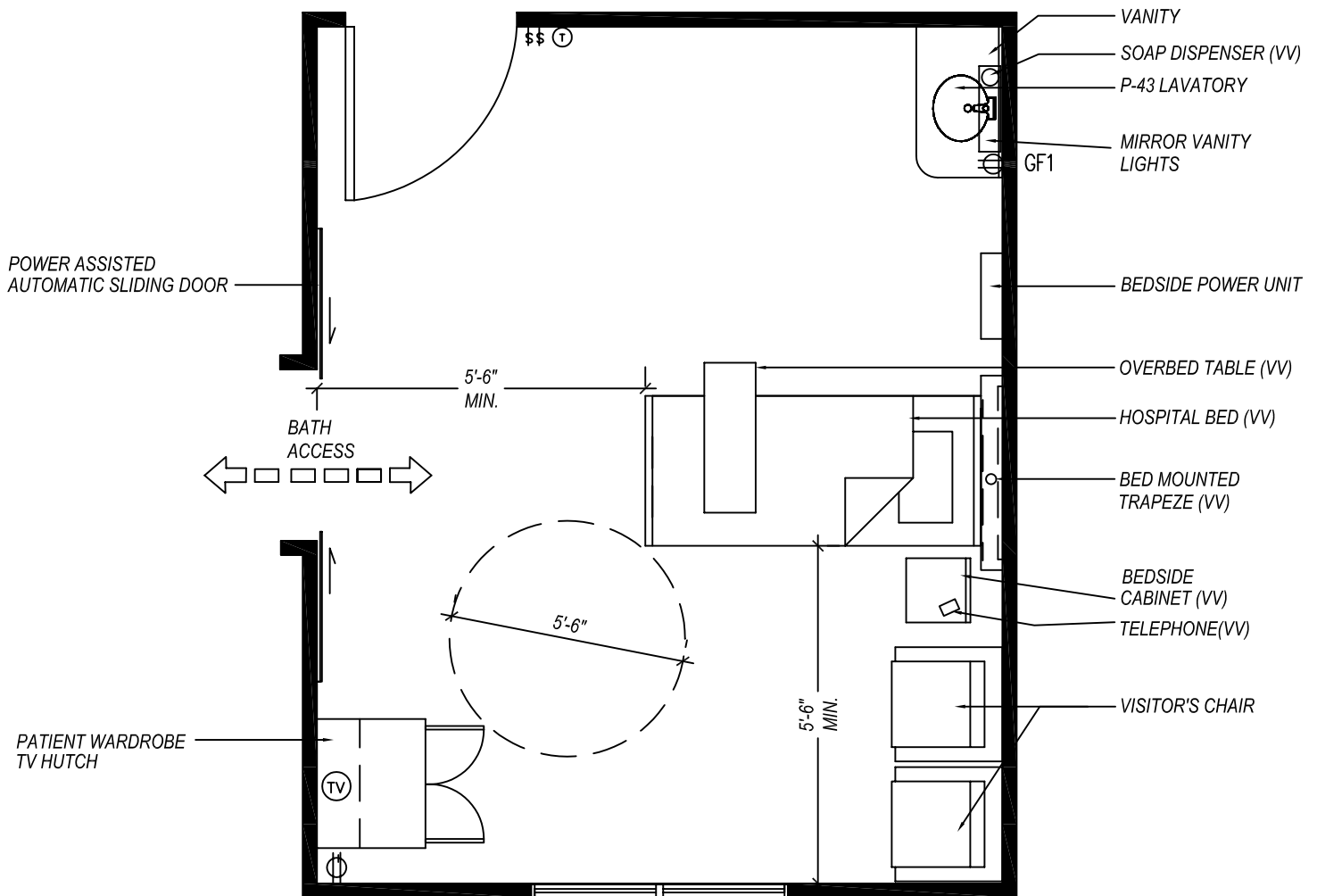
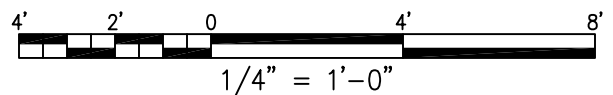

Figure 2.5.5



3. Special Care Resident Room Reflected Ceiling Plan

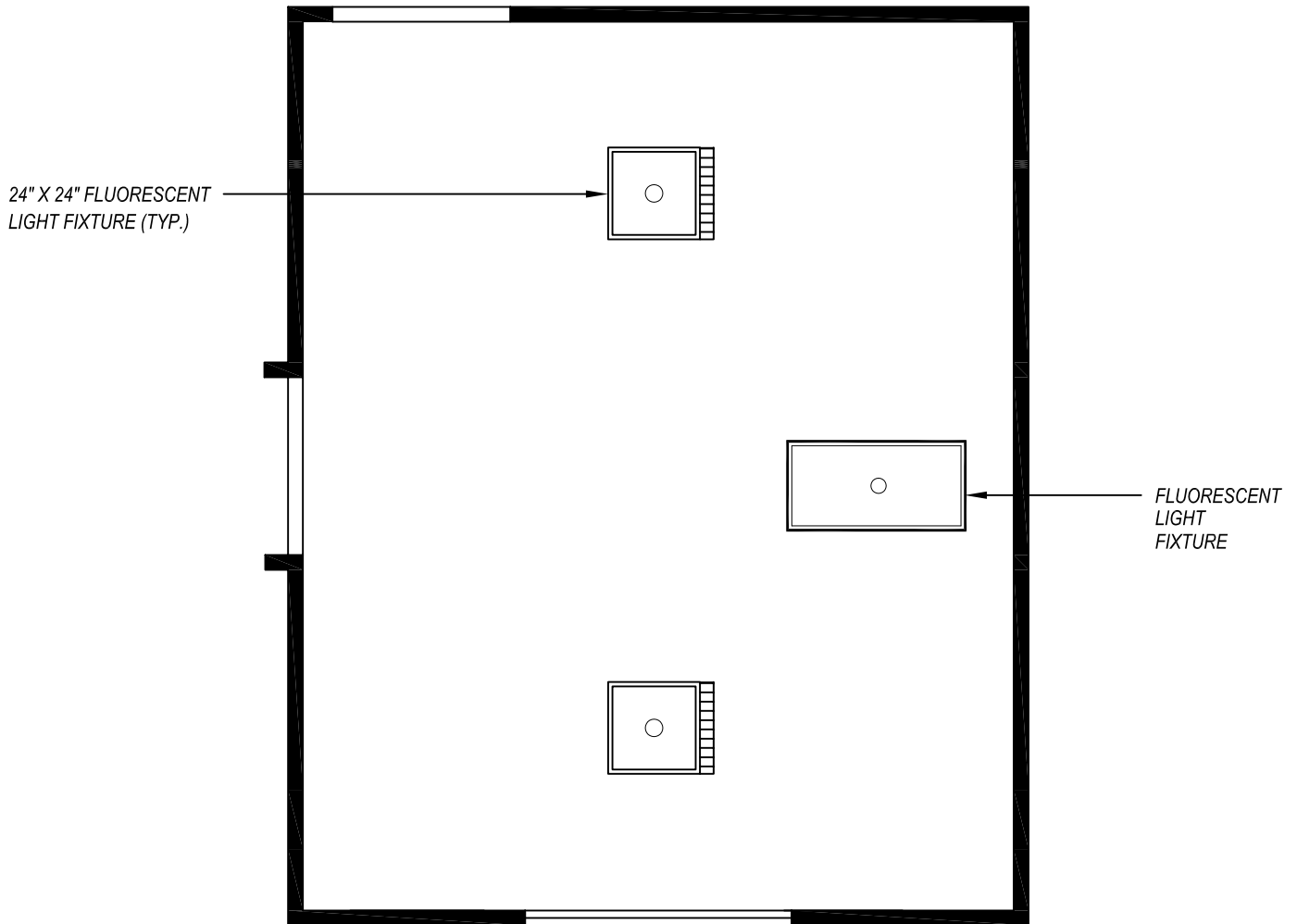
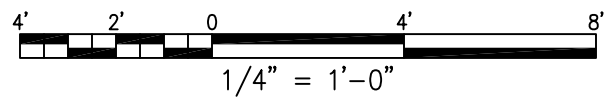

Figure 2.5.6



3. Special Care Resident Room

Function:

In long-term care, this resident room provides features that support care and routines of daily living, and facilitates one's potential to engage in activities beyond personal care. It is used by residents with special care needs such as spinal cord injury.

Space Requirement:

320 NSF [29.72 m²]

Architectural:

Finish Code:	1-A
Floor Finish:	Vinyl Composition Tile
Base:	Vinyl
Wall Finish:	Gypsum Wallboard*
Ceiling:	Acoustical Tile
Ceiling Height:	9'-0" (8' w/wall-mount TV)
Noise (STC Rating):	35
Slab Depression:	None
Special Construction:	-
Hardware:	7
Doors:	4'-0" x 7'-0" wood or metal, optional view glass panel.
Windows:	

*Vinyl Wallcovering at Lavatory

HVAC:

Temperature/Humidity:	
Summer:	76° F, Max. 50% RH
Winter:	78° F, Min. 30% RH
Min. Air Changes/Hour:	4 AC/H
Min. % Outside Air:	2 AC/H
Pressure:	N/A
Noise Criteria:	Max. 35 NC

Electrical:

Lighting Levels:	
Gen. Illum:	10 fc
Task Illum:	60 fc
Over Bed:	30 fc
Emergency	
Egress:	N/A
Emergency Power:	
Medical Gases:	N/A
Night Lights:	Y
Vanity Lights:	N/A
One Receptacle	
per PBPU:	Y
Nurse Call:	Y

3. Special Care Resident Room

Equipment Table:

SYMBOL	QUANTITY	AI	DESCRIPTION
	1		BED WITH MATTRESS, HOSPITAL PATIENT, ELECTRIC, HI-LO, 42"W X 94"L WITH 3" DIA. WHEELS AND TRAPEZE BAR
	1		BUMPER GUARD, 2" DEEP, WALL-MOUNTED OFF THE FLOOR BEHIND HEAD OF BED
	1		TABLE, OVER-BED, ADJUSTABLE HEIGHT, 33"W X 14" D, ON CASTERS
	1		CABINET, BEDSIDE, PORTABLE 20"W X 16"D X 34 ½"H
	1		CHAIR
	1		WARDROBE LOCKER, PATIENT, WITH PUSH BUTTON SECURITY LOCK, 36"W X 25 ½"D X 78"H (TOP SHELF FOR PILLOW AND BLANKET STORAGE) WALL MOUNTED
	1		PREFABRICATED BEDSIDE POWER UNIT: TYPE 3, PG-18-4, SD 16630-12.DWG and 16685-4.DWG
	1		OUTLET, MASTER TELEVISION ANTENNA (H-08-1, MCS 16781: H-08-3, CS 864-1)
	1		BRACKET FOR TELEVISION RECEIVER, CEILING-MOUNTED AT FOOT OF PATIENT BED (PG-18-1, MCS 16781)
	1		RECEIVER, TELEVISION FULL SIZE
	1		RECEPTACLE, ELECTRICAL, CEILING MOUNTED 120 VOLT, 20 AMP FOR CEILING MOUNTED TELEVISION SET (PG-18-1, MCS 16140)
	1		LIGHT, BED (ON WALL OVER BED 7 FEET ABOVE FLOOR) PG-18-1, MCS 16510)
	1		LIGHT, FLUORESCENT, FOR EXAMINATION ILLUMINATION, CEILING MOUNTED OVER EACH BED (PG-18-1, MCS 16510)
	1		LIGHT, NIGHT, INCANDESCENT, CEILING MOUNTED AT ENTRANCE TO BED ROOM WITH SWITCH AT ENTRANCE TO BED ROOM (PG-18-1, MCS 16510)
	1		VANITY, WITH HIGH PRESSURE PLASTIC LAMINATE COUNTER TOP, MOLDED SELF EDGE AND BACKSPLASH (PG-18-1, MCS 12302)
	1		LAVATORY COUNTER MOUNTED, 19" DIAMETER WRIST BLADE HANDLES, GOOSENECK SPOUT (PG-18-1 MCS 15450))
	1		DISPENSER, SOAP, LIQUID, WALL MOUNTED
	1		MIRROR, 24"W X 36"L (PG-18-1, MCS 10800)
	1		LIGHT, FLUORESCENT, VERTICAL BARS WALL MOUNTED AT EACH SIDE OF THE MIRROR (PG-18-1, MCS 16510)

	1		DISPENSER, PAPER TOWEL AND DISPOSAL COMBINATION UNITS (PG-18-1, MCS 10800)
	1		RECEPTACLE, ELECTRICAL, 120 VOLT, 20 AMP WITH GROUND FAULT INTERRUPTER, ADJACENT TO LAVATORY (PG-18-1, MCS 16140)
	1		LIGHT, NIGHT, (PG-18-1, MCS 16510)
	1		RECEPTACLE, ELECTRICAL, DUPLEX, 120 VOLT, 20 AMP (PG-18-1, MCS 16140)
	1		CALL, NURSES PANEL, WITH CORRIDOR SIGNAL LIGHT (PG-18-1, MCS 16761)
			OBSERVATION WINDOW ON CORRIDOR WALL, FIXED FRAME WITH INTEGRAL BLIND CONTROLLED FROM INSIDE THE ISOLATION ROOM.

TABLE 2.5.3
Special Care Resident Room

4. Resident Toilet Room - 58 NSF [2.79 m²]

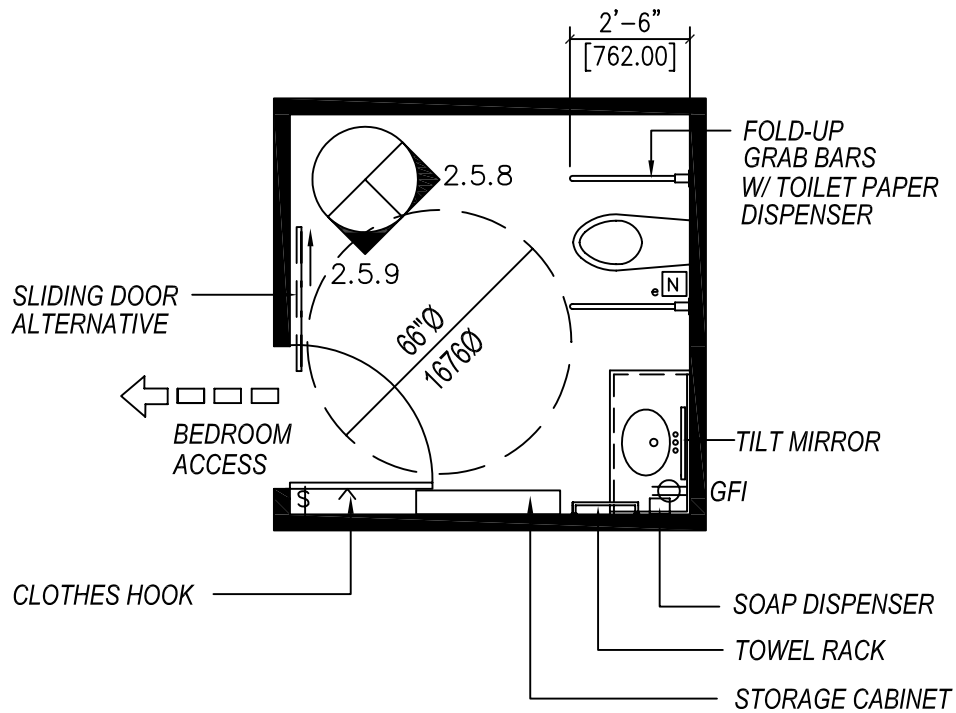

Figure 2.5.7

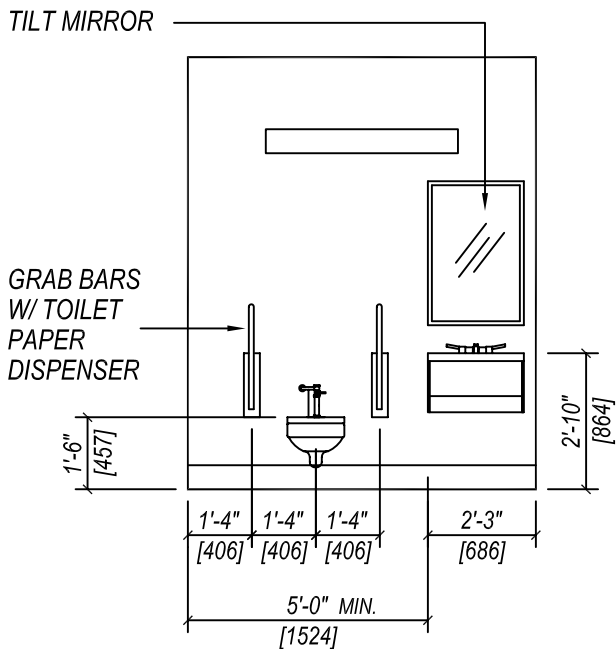

Figure 2.5.8

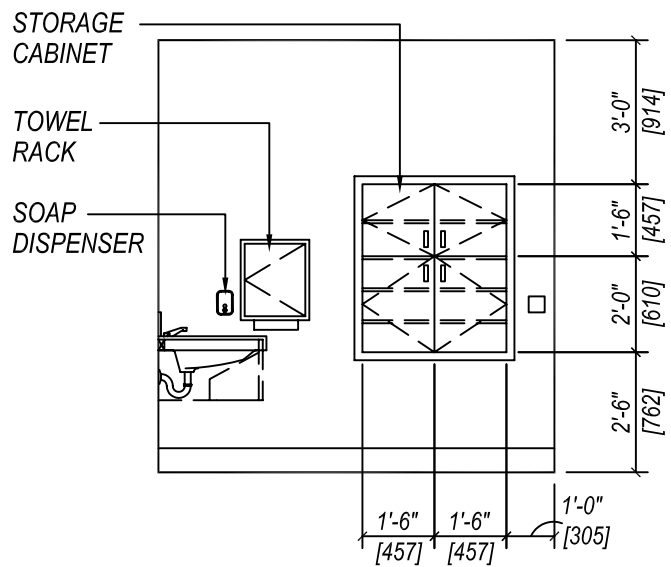
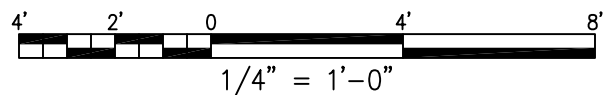

Figure 2.5.9



4. Resident Toilet Room Reflected Ceiling Plan

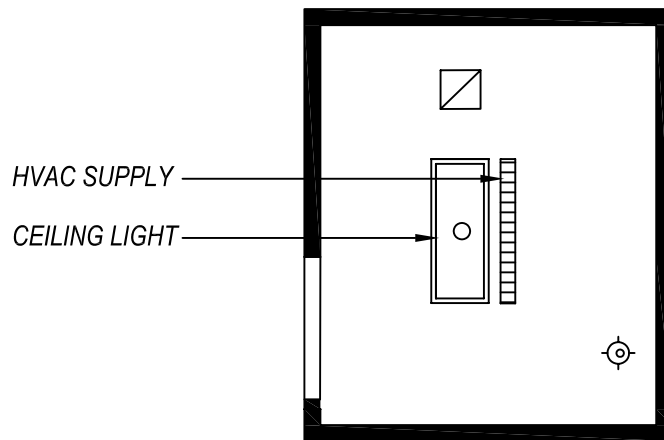
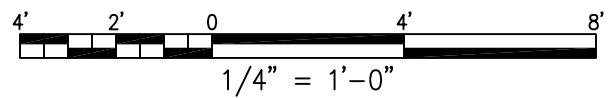

Figure 2.5.10



4. Resident Toilet Room

Function:

The resident toilet room is used by one or two residents with or without staff or caregiver assistance for toileting and personal grooming and is equipped with a toilet and lavatory.

Space Requirement:

58 NSF [2.79 m²]

Architectural:

Finish Code:	1-A
Floor Finish:	Ceramic Tile
Base:	Ceramic Tile
Wall Finish:	Gypsum Wallboard
Ceiling:	Gypsum Wallboard
Ceiling Height:	9'-0"
Wainscot	Ceramic Tile 4'-0"
Noise (STC Rating):	35
Slab Depression:	None
Special Construction:	-
Hardware:	14
Doors:	3'-0" x 7'-0" wood or metal,
Windows:	

HVAC:

Temperature/Humidity:	
Summer:	78° F
Winter:	72° F
Min. Air Changes/Hour:	10 AC/H
Min. % Outside Air:	N/A
Pressure:	Negative
Noise Criteria:	Max. 40 NC

Electrical:

Lighting Levels:	
Gen. Illum:	30 fc
Task Illum:	30 fc
Over Bed:	N/A
Emergency	
Egress:	N/A
Emergency Power:	
Medical Gases:	N/A
Night Lights:	N/A
Vanity Light:	Y
One Receptacle	
per PBPU:	N/A
Nurse Call:	Y

4. Resident Toilet Room

Equipment Table:

SYMBOL	QUANTITY	AI	DESCRIPTION
	1		BAR, GRAB, UP-SWINGING FOR WATER CLOSET WITH DISPENSER, TOILET TISSUE, DOUBLE ROLL
	1		LAVATORY, STRAIGHT BACK
	1		BAR, TOWEL
	1		DISPENSER, SOAP, LIQUID, WALL MOUNTED
	1		MIRROR, WHEELCHAIR, 610 mm X 914 mm (24" X 36")
	1		LIGHT, OVER MIRROR
	1		HOOK, CLOTHES, INSTALL ON DOOR, TOILET SIDE
	AR		RECEPTACLE, ELECTRICAL, DUPLEX, 120 VOLT, 20 AMP, WITH GROUND FAULT INTERRUPTER, ADJACENT TO LAVATORY

TABLE 2.5.4
Resident Toilet Room

5. Resident Toilet/Shower Room - 90 NSF [8.36 m²]

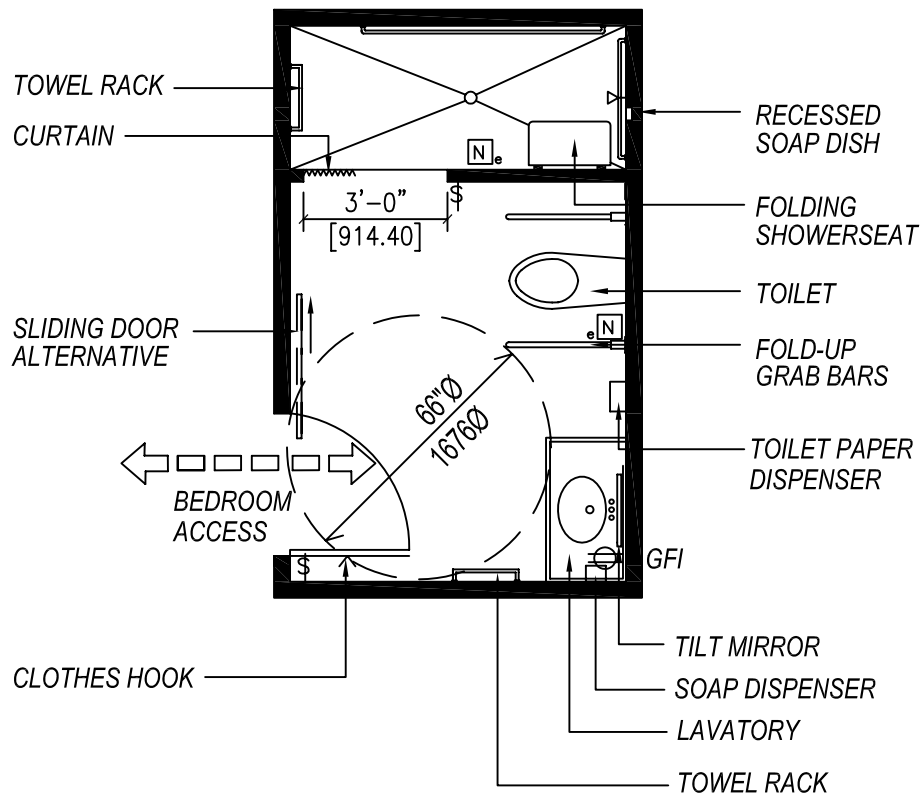
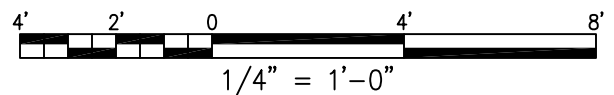

Figure 2.5.11



5. Resident Toilet/Shower Room Reflected Ceiling Plan

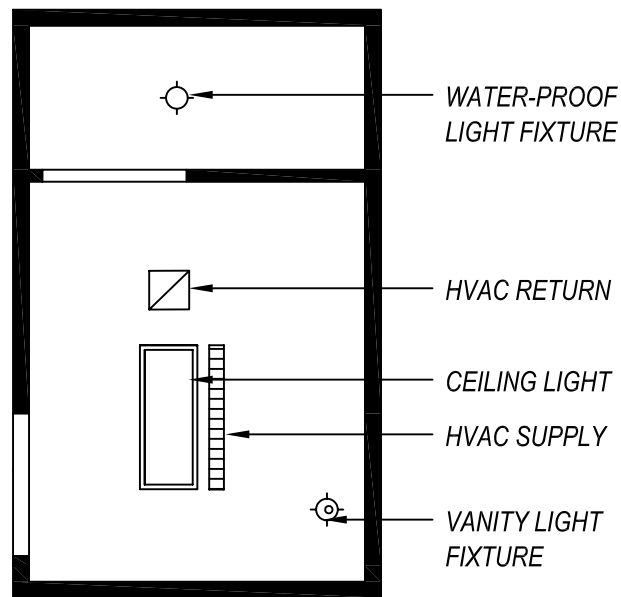
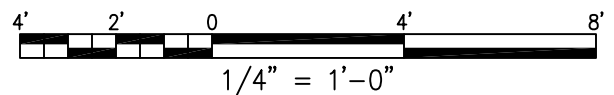

Figure 2.5.12



5. Resident Toilet/Shower Room

Function:

The resident toilet/shower room is used by one or two patients with or without staff or caregiver assistance for toileting/showering and personal grooming. It is equipped with a shower, toilet and a lavatory.

Space Requirement:

90 NSF [8.36 m²]

Architectural:

Finish Code:	1-A
Floor Finish:	Ceramic Tile
Base:	Ceramic Tile
Wall Finish:	Gypsum Wallboard
Ceiling:	Gypsum Wallboard
Ceiling Height:	9'-0"
Wainscot:	Ceramic Tile 4'-0"
Noise (STC Rating):	35
Slab Depression:	None
Special Construction:	-
Hardware:	14
Doors:	3'-0" x 7'-0" wood or metal,
Windows:	

*Ceramic tile full height tub/shower on concrete backer board.

HVAC:

Temperature/Humidity:	
Summer:	78° F
Winter:	72° F
Min. Air Changes/Hour:	10 AC/H
Min. % Outside Air:	N/A
Pressure:	Negative
Noise Criteria:	Max. 40 NC

Electrical:

Lighting Levels:	
Gen. Illum:	30 fc
Task Illum:	30 fc
Over Bed:	N/A
Emergency	
Egress:	N/A
Emergency Power:	
Medical Gases:	N/A
Night Lights:	N/A
Vanity Light:	Y
One Receptacle	
per PBPU:	N/A
Nurse Call:	Y

5. Resident Toilet/Shower Room

Equipment Table:

SYMBOL	QUANTITY	AI	DESCRIPTION
	1		BAR, GRAB, UP-SWINGING FOR WATER CLOSET WITH DISPENSER, TOILET TISSUE, DOUBLE ROLL
	1		LAVATORY, STRAIGHT BACK
	1		BAR, TOWEL
	1		DISPENSER, SOAP, LIQUID, WALL MOUNTED
	1		MIRROR, WHEELCHAIR, 610 mm X 914 mm (24" X 36")
	1		LIGHT, OVER MIRROR
	1		HOOK, CLOTHES, INSTALL ON DOOR, TOILET SIDE
	AR		RECEPTACLE, ELECTRICAL, DUPLEX, 120 VOLT, 20 AMP, WITH GROUND FAULT INTERRUPTER, ADJACENT TO LAVATORY
	1		SHOWER, BATH FIXTURE, DETACHABLE, WALL MOUNTED, CONCEALED SUPPLIES
	1		DISH, SOAP, RECESSED
	1		BAR, GRAB FOR TUB OR SHOWER
	1		BAR, TOWEL
	1		ROD, CURTAIN, TUB OR SHOWER
	1		CURTAIN - TUB OR SHOWER
	1		HOOK, CLOTHES, INSTALL ON DOOR, TOILET SIDE
	1		FOLDING SHOWER SEAT

TABLE 2.5.5
Resident Toilet/Shower Room

6. Bathing Suite (Spa Bather) - 360 NSF [33.45 m²]

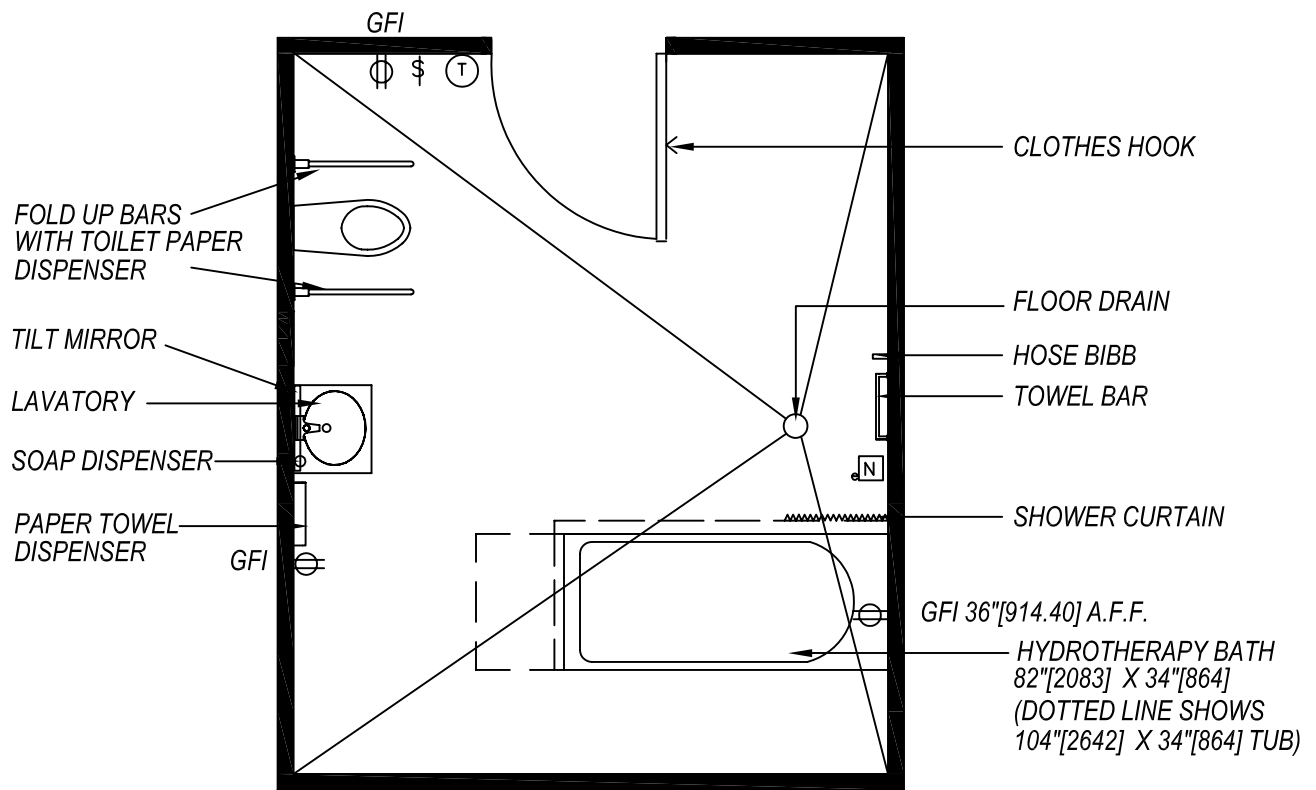
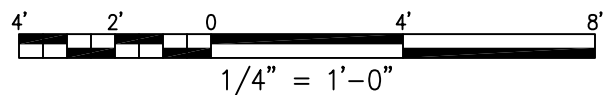

Figure 2.5.13



6. Bathing Suite (Spa Bather) Reflected Ceiling Plan

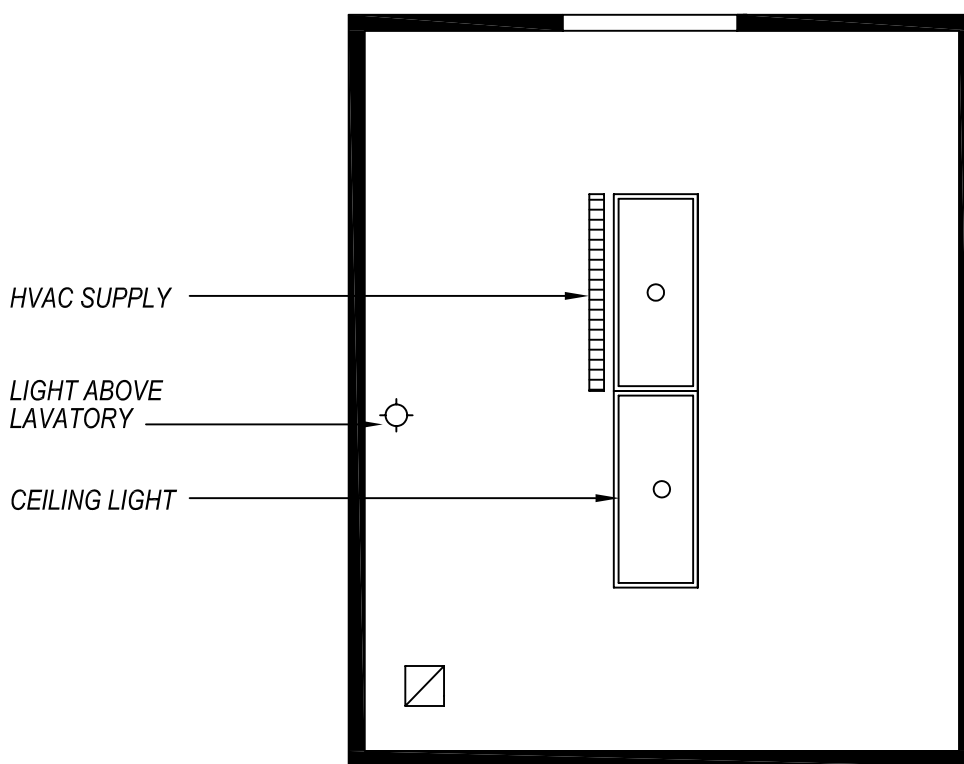
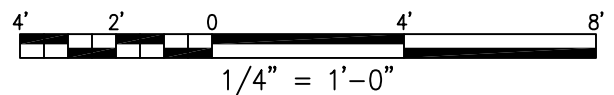

Figure 2.5.14



6. Bathing Suite (Spa Bather)

Function:

The bathing suite, or spa bather, is used typically for one patient at a time with staff assistance for immersion bathing and personal grooming. In addition to the bathing equipment, the bathing suite typically includes a lavatory and toilet.

Space Requirement:

360 NSF [33.45 m²]

Architectural:

Finish Code:	1-A
Floor Finish:	Ceramic Tile
Base:	Ceramic Tile
Wall Finish:	Gypsum Wallboard
Ceiling:	Gypsum Wallboard
Ceiling Height:	9'-0"
Wainscot	Ceramic Tile*
Noise (STC Rating):	35
Slab Depression:	None
Special Construction:	-
Hardware:	14
Doors:	3'-8" x 7'-0" wood or metal.
Windows:	

*Ceramic tile full height tub/shower on concrete backer board.

HVAC:

Temperature/Humidity:	
Summer:	78° F
Winter:	72° F
Min. Air Changes/Hour:	10 AC/H
Min. % Outside Air:	N/A
Pressure:	Negative
Noise Criteria:	Max. 40 NC

Electrical:

Lighting Levels:	
Gen. Illum:	30 fc
Task Illum:	N/A
Over Bed:	N/A
Emergency	
Egress:	N/A
Emergency Power:	N/A
Medical Gases:	N/A
Night Lights:	N/A
Vanity Light:	N/A
One Receptacle	
per PBPU:	N/A
Nurse Call:	Y

6. Bathing Suite (Spa Bather)

Equipment Table:

SYMBOL	QUANTITY	AI	DESCRIPTION
	1		ROD, CURTAIN, SHOWER
	1		CURTAIN, SHOWER
	1		BATH, HYDROTHERAPY, THERMOSTATIC CONTROL, APPROX. OUTSIDE DIMENSIONS, 914 mm X 1829 mm X 711 mm (36" X 72" X 28")
	1		HOOK, CLOTHES
	1		BAR, TOWEL
	1		HOSE BIBB, COMBINATION FAUCET, WALL MOUNTED, CONCEALED SUPPLY PIPES
	1		FLOOR DRAIN, IN DRYING AREA (PLUMBING DESIGN CRITERIA AND INSTRUCTIONS)
	1		WATER CLOSET, WALL HUNG
	1		BAR, FOLD UP GRAB FOR WATER CLOSET WITH TOILET PAPER DISPENSER
	1		LAVATORY, STRAIGHT BACK
	1		DISPENSER, SOAP, LIQUID, WALL MOUNTED
	1		MIRROR, WHEELCHAIR, 610 mm X 914 mm (24" X 36")
	1		LIGHT, OVER MIRROR
	AR		RECEPTACLE, ELECTRICAL, DUPLEX, 120 VOLT, 20 AMP, WITH GROUND FAULT INTERRUPTER, ADJACENT TO LAVATORY

TABLE 2.5.6
Bathing Suite (Spa Bather)

7. Nurses' Station - 205 NSF [19 m²]

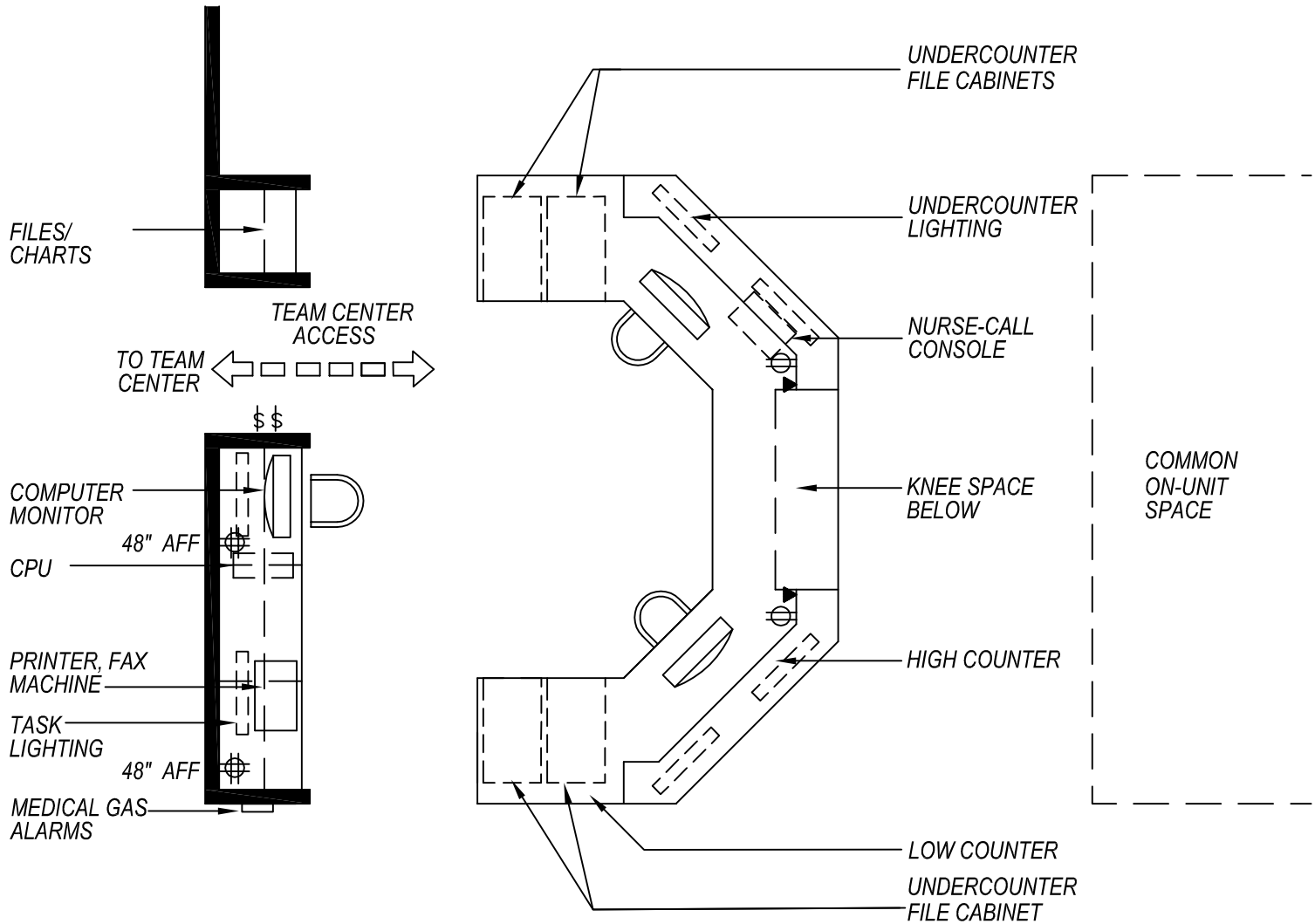

See Part 3.0 Planning and Design Data for preferred On Unit, Dynamic Cluster Desks.
 Room size is variable, use project-specific program for actual size.

Figure 2.5.15

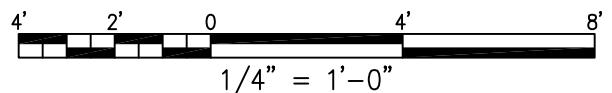

7. Nurses' Station Reflected Ceiling Plan

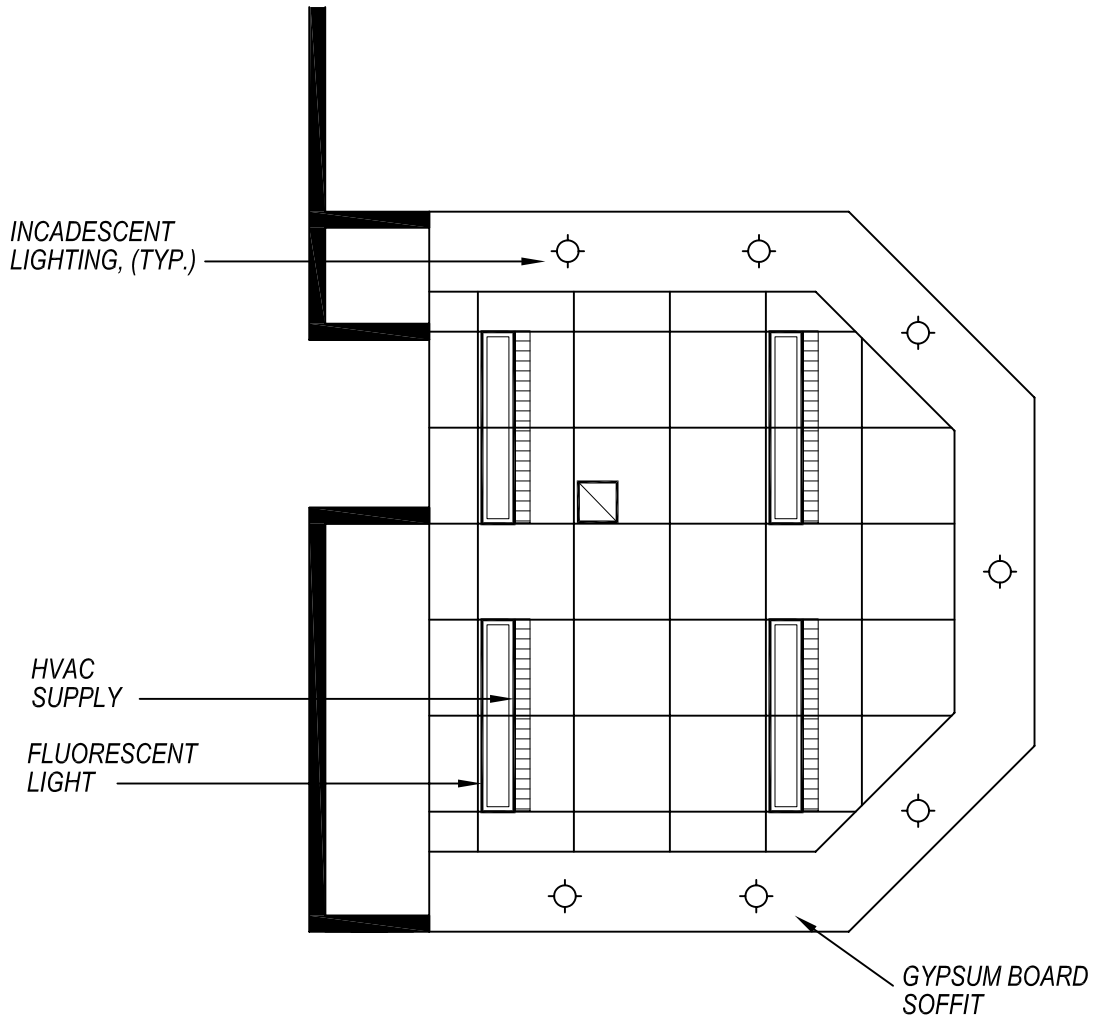

Room size is variable, see project-specific program for actual size.

Figure 2.5.16

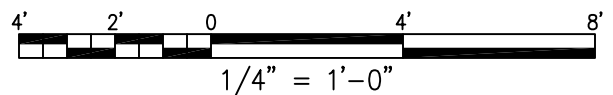

7. Nurses Station

Function:

The nurses station is used by nursing and other clinical staff assigned to patient care; equipped with work stations with computer, printer, and storage.

Space Requirement:

205 NSF [19 m²]

Architectural:

Finish Code:	1-A
Floor Finish:	Vinyl Composition Tile/ Carpet
Base:	Vinyl
Wall Finish:	Gypsum Wallboard – Vinyl Coated Fabric Wallcovering
Ceiling:	Acoustical Tile
Ceiling Height:	9'-0"
Noise (STC Rating):	35
Slab Depression:	None
Special Construction:	-
Hardware:	23
Doors:	
Windows:	

HVAC:

Temperature/Humidity:	
Summer:	78° F, Max. 50% RH
Winter:	72° F, Max. 30% RH
Min. Air Changes/Hour:	-
Min. % Outside Air:	As per ASHRAE Std 62
Pressure:	N/A
Noise Criteria:	Max. 40 NC

Electrical:

Lighting Levels:	
Gen. Illum:	70 fc
Task Illum:	30 fc
Over Bed:	30 fc night
Emergency	
Egress:	1 fc Ave.
Emergency Power:	
Medical Gases:	Y
Night Lights:	Y
Vanity Light:	N/A
One Receptacle	
per PBPU:	N/A
Nurse Call:	Y

7. Nurses Station

Equipment Table:

SYMBOL	QUANTITY	AI	DESCRIPTION
	AR		UNDER-COUNTER FILE CABINETS
	3		COMPUTER MONITOR, CPU
	1		PRINTER, FAX MACHINE
	1		COUNTER, CENTER, COMMUNICATION, WITH DESK, BUILT-IN WITH TYPEWRITER WELL, INDIVIDUAL SINGLE DRAWERS BELOW FULL LENGTH OF COUNTER AS REQUIRED, SIZE ACCORDING TO INDIVIDUAL PROJECT DESIGN
	AR		LIGHT, UNDER, COUNTER TOP, STRIP TYPE
	AR		RECEPTACLE, ELECTRICAL, DUPLEX, 120 VOLT, 20 AMP
	AR		CHAIR, ROTARY, WITHOUT ARMS
	AR		CHAIR, STRAIGHT, WITH ARMS

TABLE 2.5.7
Nurses Station

8. Clean Utility - 120 NSF [11.15 m²]

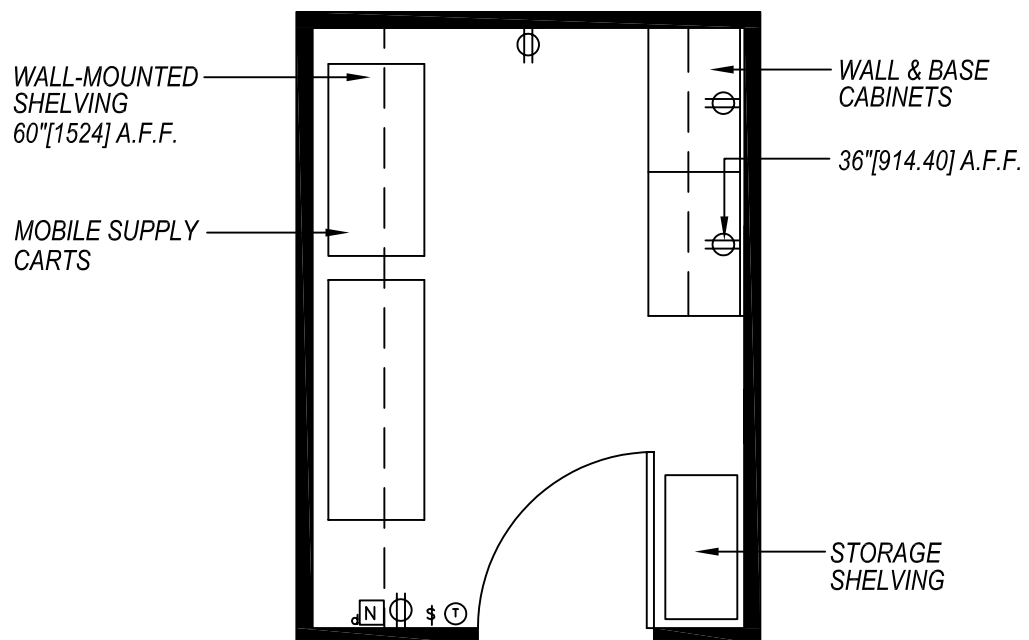
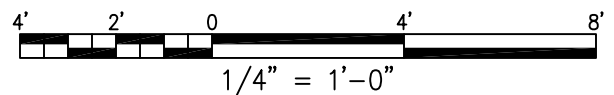

Figure 2.5.17



8. Clean Utility Reflected Ceiling Plan

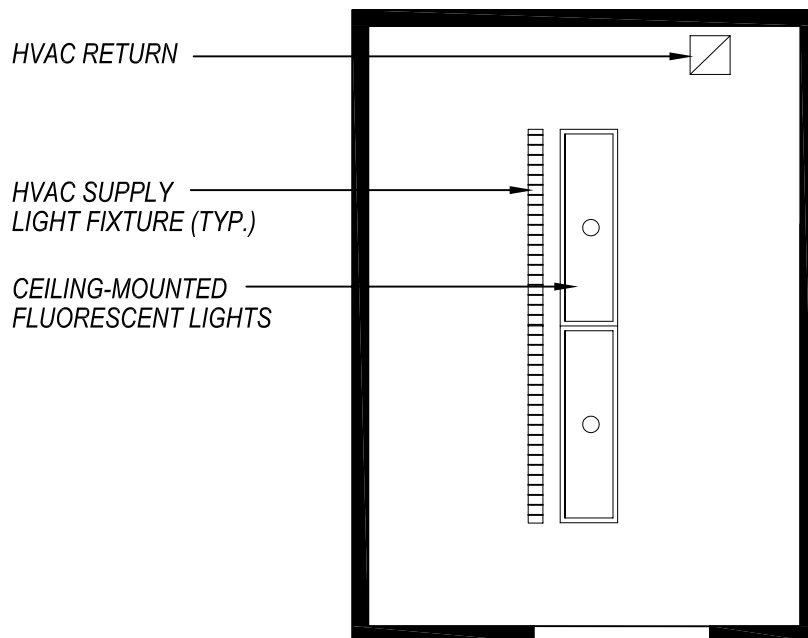
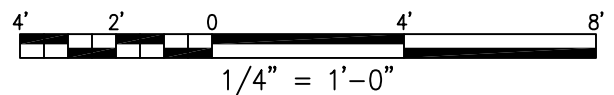

Figure 2.5.18



8. Clean Utility Room

Function:

The clean utility is used by unit staff for storage of medical supply carts and other supplies. It is accessed by Supply/SPD staff to replenish supplies.

Space Requirement:

120 NSF [11.15 m²]

Architectural:

Finish Code:	1-A
Floor Finish:	Vinyl Composition Tile
Base:	Vinyl
Wall Finish:	Gypsum Wallboard (Structural Clay)
Ceiling:	Gypsum Wallboard
Ceiling Height:	9'-0"
Noise (STC Rating):	35
Slab Depression:	None
Special Construction:	-
Hardware:	45
Doors:	4'-0" x 7'-0" wood or metal.
Windows:	

HVAC:

Temperature/Humidity:	
Summer:	78° F, Max. 50% RH
Winter:	72° F, Min. 30% RH
Min. Air Changes/Hour:	4 AC/H
Min. % Outside Air:	2%
Pressure:	Positive
Noise Criteria:	Max. 40 NC

Electrical:

Lighting Levels:	
Gen. Illum:	20 fc
Task Illum:	N/A
Over Bed:	N/A
Emergency	
Egress:	N/A
Emergency Power:	
Medical Gases:	N/A
Night Lights:	N/A
Vanity Light:	N/A
One Receptacle	
per PBPU:	N/A
Nurse Call:	Y

8. Clean Utility Room

Equipment Table:

SYMBOL	QUANTITY	AI	DESCRIPTION
	1		CARTS, CLEAN, LINEN, APPROX., 622 mm X 1549 mm X 1816 mm (24-1/2" X 61" X 71-1/2")
	1		SHELVING, WALL HUNG, STEEL, WITH 2 ADJUSTABLE SHELVES AND DOORS, 914 mm X 559 mm X 1067 mm (36" X 22" X 42")
	AR		RECEPTACLE, ELECTRICAL, DUPLEX, 120 VOLT, 20 AMP

TABLE 2.5.8
Clean Utility Room

9. Soiled Linen/Utility - 100 NSF [9.29 m²]

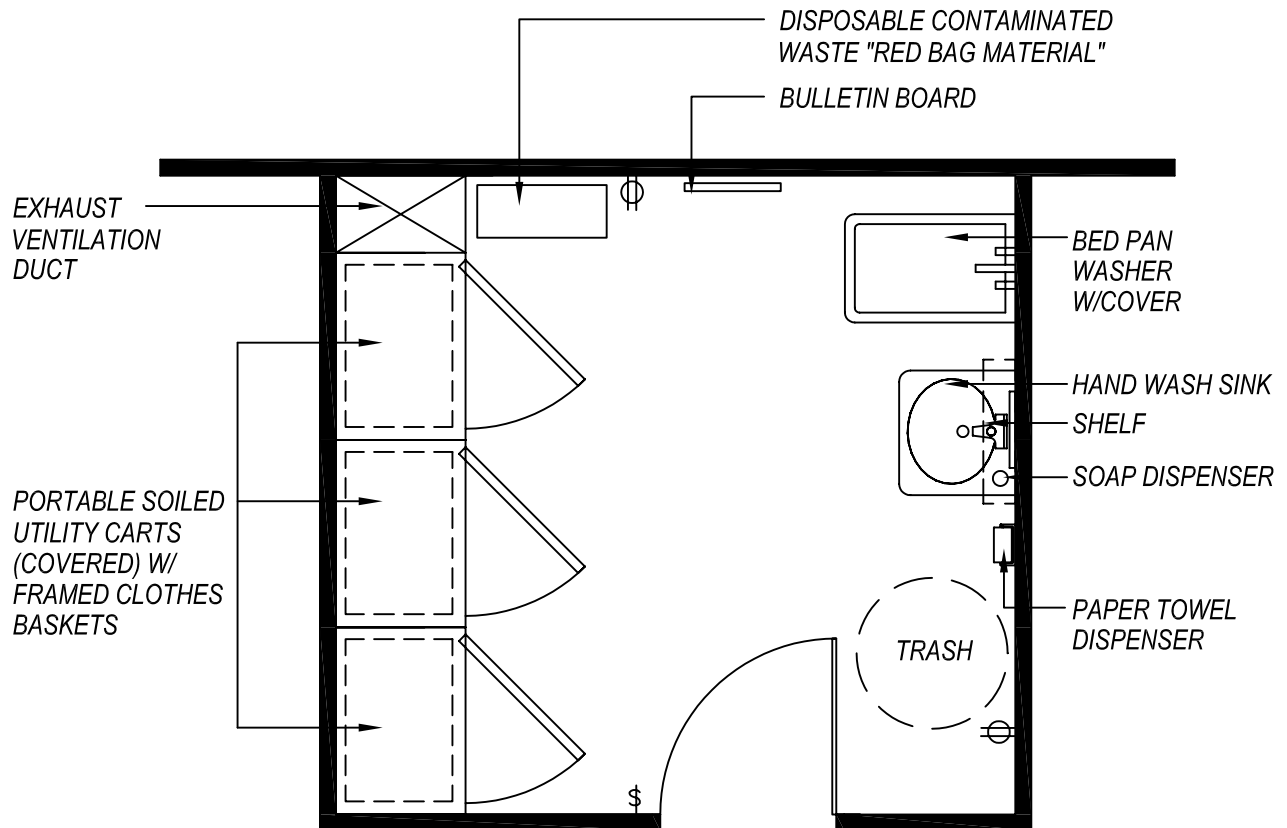
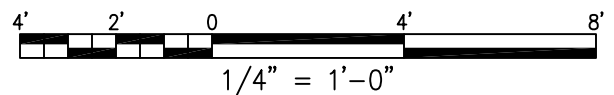

Figure 2.5.19



9. Soiled Linen/Utility Reflected Ceiling Plan

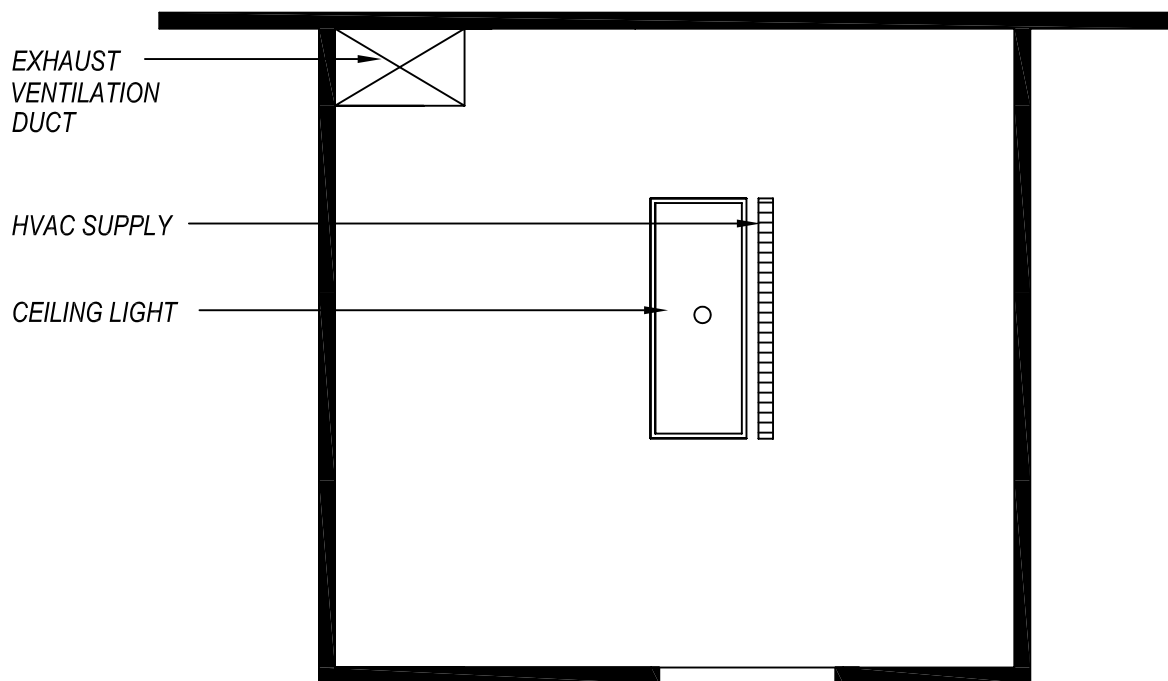
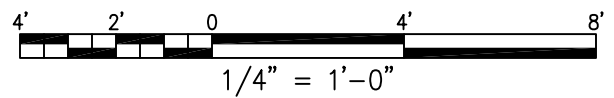

Figure 2.5.20



9. Soiled Linen/Utility

Function:

The soiled utility is used by unit staff for collection of soiled linen and trash in carts. It is accessed by Building Management staff for linen/trash removal.

Space Requirement:

100 NSF [9.29 m²]

Architectural:

Finish Code:	1-A
Floor Finish:	Resilient Surface Flooring
Base:	Vinyl
Wall Finish:	Gypsum Wallboard (Structural Clay)
Ceiling:	Gypsum Wallboard
Ceiling Height:	9'-0"
Noise (STC Rating):	35
Slab Depression:	None
Special Construction:	-
Hardware:	45
Doors:	3'-8" x 7'-0" wood or metal.
Windows:	

HVAC:

Temperature/Humidity:	
Summer:	78° F, Max. 50% RH
Winter:	72° F, Min. 30% RH
Min. Air Changes/Hour:	10 AC/H
Min. % Outside Air:	2%
Pressure:	Negative
Noise Criteria:	Max. 40 NC

Electrical:

Lighting Levels:	
Gen. Illum:	10 fc
Task Illum:	N/A
Over Bed:	N/A
Emergency	
Egress:	N/A
Emergency Power:	
Medical Gases:	N/A
Night Lights:	N/A
Vanity Light:	N/A
One Receptacle	
per PBPU	N/A
Nurse Call:	N/A

9. Soiled Linen/Utility

Equipment Table:

SYMBOL	QUANTITY	AI	DESCRIPTION
	1		SINK, SERVICE, CLINIC, FLUSHING RIM, WALL HUNG
	1		SHELF, CORROSION RESISTING STEEL, 914 mm X 203 mm (36" X 8")
	1		DISPENSER, SOAP, WITH FOOT CONTROL, WALL MOUNTED OVER SINK
	1		DISPENSER, PAPER TOWEL, SURFACE MOUNTED
	3		FRAME, CLOTHES BASKET, SOILED LINEN, APPROX., 660 mm X 914 mm X 699 mm (26" X 36" X 27-1/2")
	AR		RECEPTACLE, WASTE, STEP ON TYPE, APPROX., 305 mm (12") DIAMETER
	3		CARTS, 610 mm X 610 mm (24" X 24")
	1		BULLETIN BOARD, 610 mm X 457 mm (24" X 18")
	AR		RECEPTACLE, ELECTRICAL, DUPLEX, 120 VOLT, 20 AMP
	1		DISPOSABLE CONTAMINATED WASTE "RED BAG MATERIAL"

TABLE 2.5.9
Soiled Linen/Utility

10. Resident Dining Room - 1000 NSF [92.90 m²]

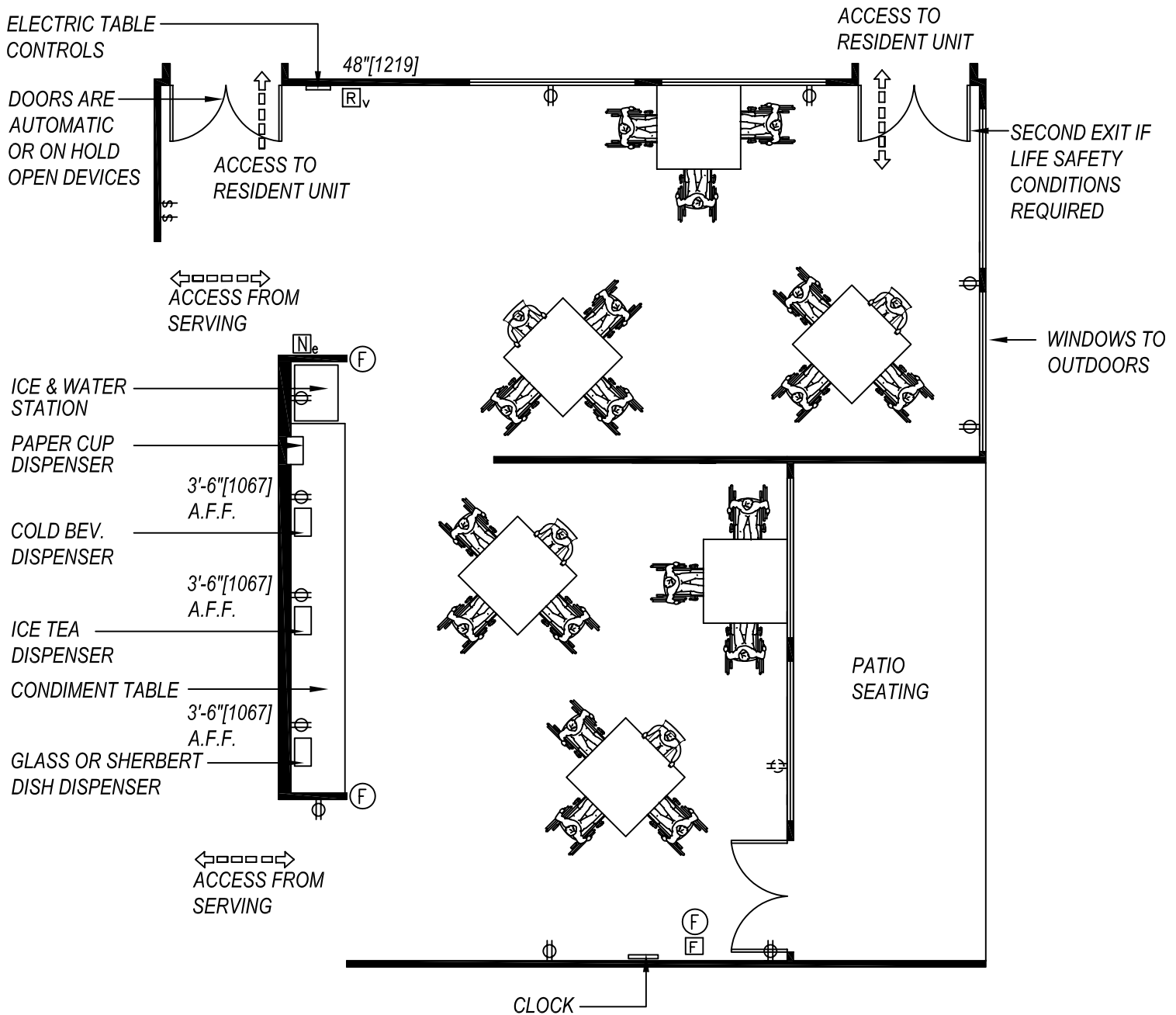
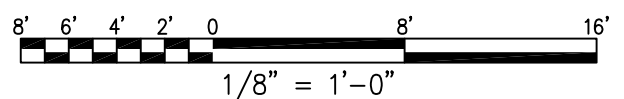

Figure 2.5.21



10. Resident Dining Room Reflected Ceiling Plan

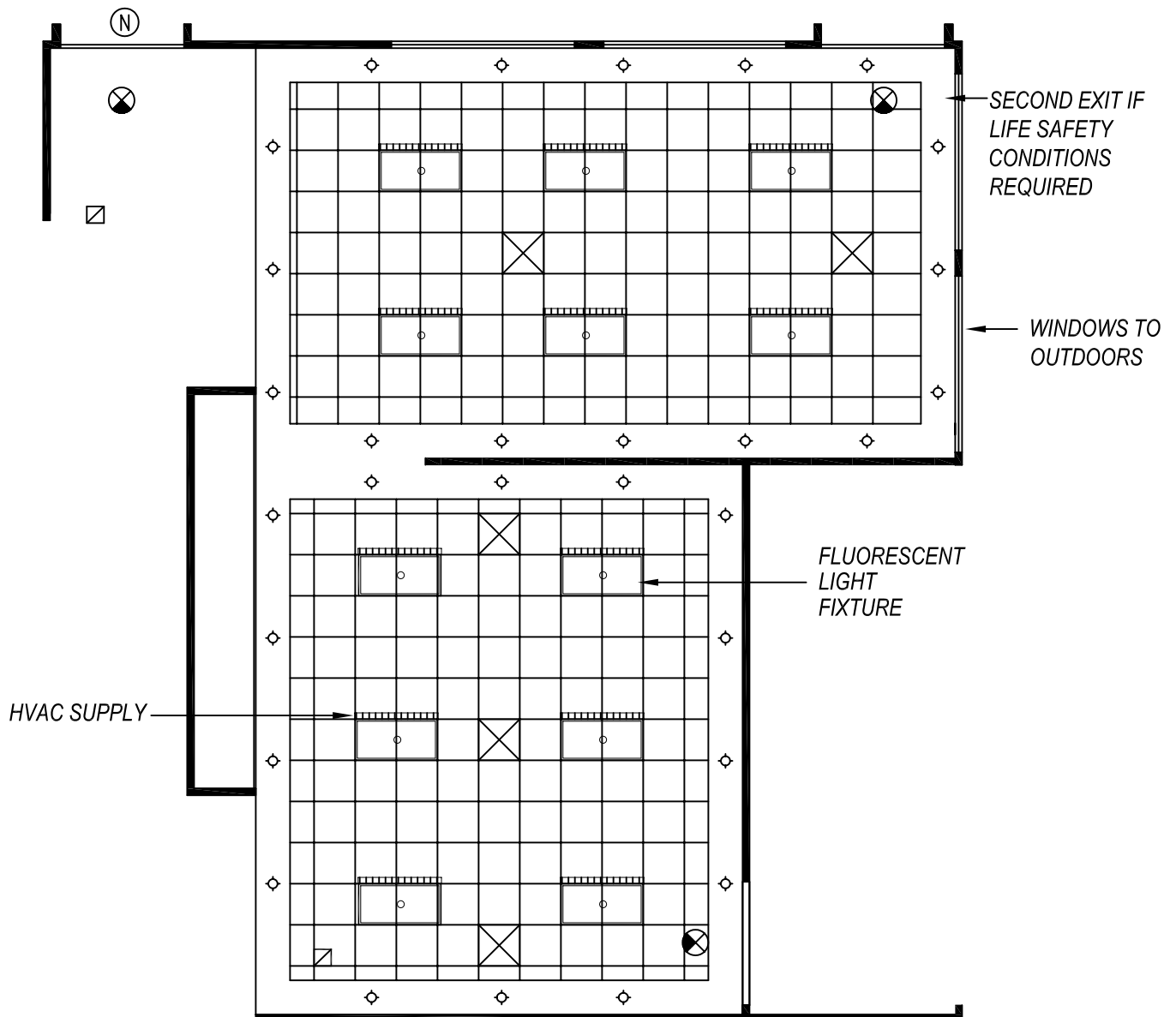
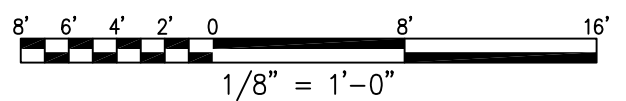

Figure 2.5.22



10. Resident Dining Room

Function:

The resident dining room is used by residents with staff assistance for on-unit dining on a daily basis. The resident dining room may be used for other purposes such as recreation therapy during non-dining hours.

Space Requirement:

1000 NSF [92.90 m²]

Architectural:

Finish Code:	1-A
Floor Finish:	Vinyl Composition Tile
Base:	Vinyl
Wall Finish:	Gypsum Wallboard – Vinyl Coated Fabric Wallcovering
Ceiling:	Acoustical Tile
Ceiling Height:	10'-0"
Noise (STC Rating):	35
Slab Depression:	None
Special Construction:	-
Hardware:	126
Doors:	2 - 3'-0" x 7'-0" wood or metal, optional view glass panel.
Windows:	

HVAC:

Temperature/Humidity:	
Summer:	78° F, Max. 50% RH
Winter:	72° F, Min. 30% RH
Min. Air Changes/Hour:	10 AC/H
Min. % Outside Air:	As per ASHRAE Std 62
Pressure:	-
Noise Criteria:	Max. 45 NC

Electrical:

Lighting Levels:	
Gen. Illum:	30fc
Task Illum:	N/A
Over Bed:	N/A
Emergency	
Egress:	1 fc Ave.
Emergency Power:	
Medical Gases:	N/A
Night Lights:	N/A
Vanity Light:	N/A
One Receptacle	
per PBPU:	N/A
Nurse Call:	Y

10. Resident Dining Room

Equipment Table:

SYMBOL	QUANTITY	AI	DESCRIPTION
	AR		CHAIRS, DINING
	AR		TABLE, DINING, SQUARE
	1		ICE AND WATER STATION WITH AUTOMATIC ICE MAKER AND DISPENSER, FLOOR MOUNTED, 227 KG (500 LB.), PER DAY, 45 KG (100 LB.), BIN, 914 mm X 711 mm X 2134 mm (36" X 28" X 84")
	1		DISPENSER, PAPER CUP, RECESSED TYPE, TWIN STACK, 177 ML (6 OUNCE) CUPS, WITH DISPOSAL COMBINATION UNITS, LOCATE ADJACENT TO WATER STATION
	1		NURSE CALL, EMERGENCY STATION WITH CORRIDOR SIGNAL LIGHT CONNECTED TO NEAREST NURSE CONTROL STATION
	1		SPEAKER, WITH CHANNEL SELECTOR AND VOLUME CONTROL, HOSPITAL RADIO SYSTEM
	1		DISPENSER, GLASS OR SHERBERT DISH, MOBILE, 787 mm X 584 mm X 914 mm (31" X 23" X 36")
	1		DISPENSER, BEVERAGE COLD
	1		DISPENSER, ICE TEA, PORTABLE (TO BE PLACED ON K-9110)
	1		CLOCK, BATTERY OPERATED
	1		RECEPTACLE, ELECTRICAL, DUPLEX, 120 VOLT, 20 AMP

TABLE 2.5.10
Resident Dining Room

11. Corridor

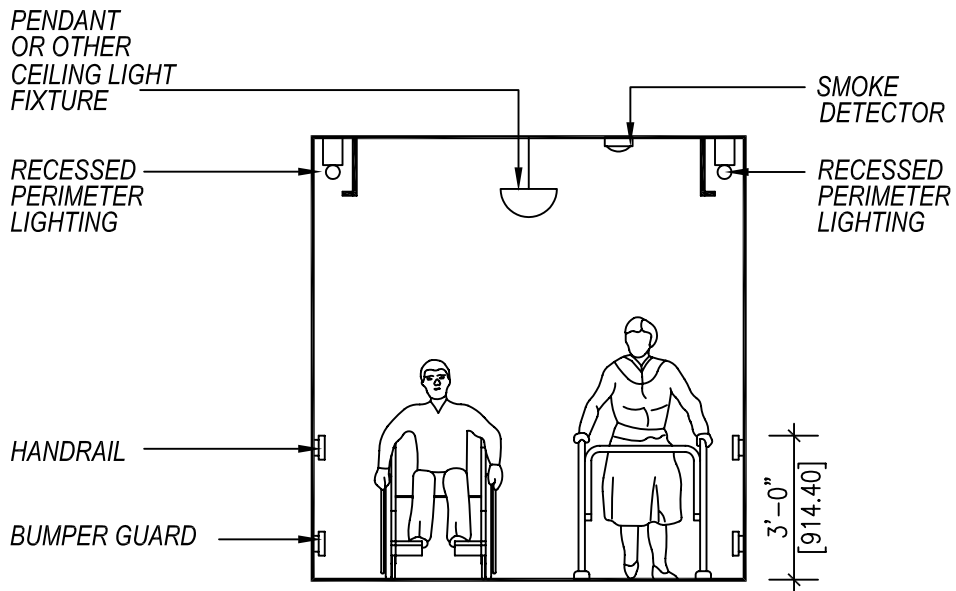
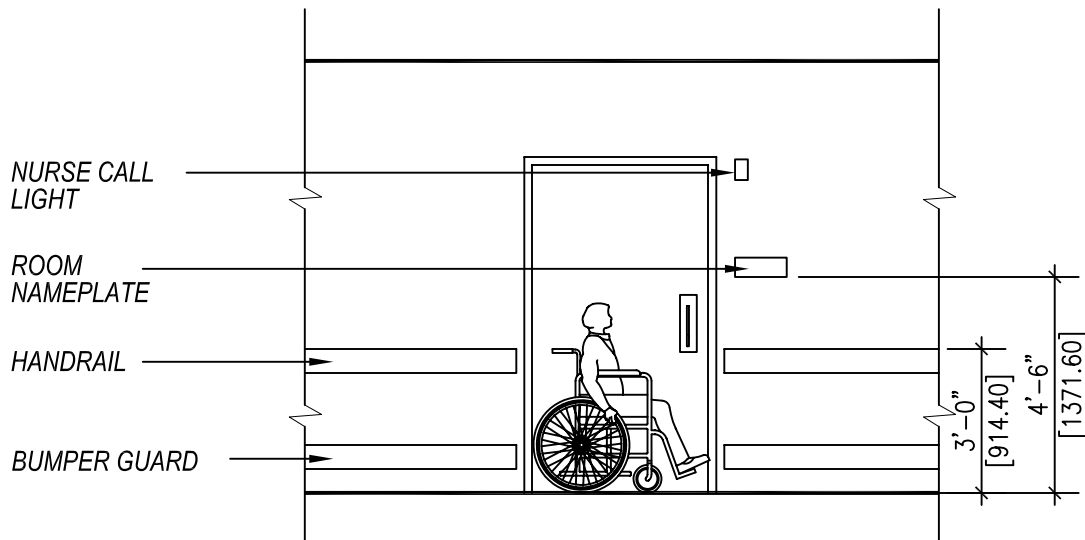
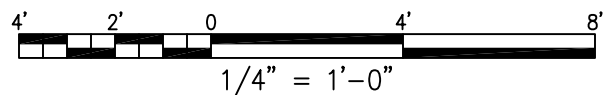

Figure 2.5.23



11. Corridor

Function:

The corridors are used by residents and staff for circulation within the facility.

Space Requirement:

Architectural:

Finish Code:	1-A
Floor Finish:	Vinyl Composition Tile
Base:	Vinyl
Wall Finish:	Gypsum Wallboard*
Ceiling:	Acoustical Tile
Ceiling Height:	9'-0" (8' w/wall-mount TV)
Noise (STC Rating):	35
Slab Depression:	None
Special Construction:	-
Hardware:	6
Doors:	3'-8" x 7'-0" wood or metal, optional view glass panel.
Windows:	Required by code, operable, see PG-18-3, Topic 1, Codes and Standards.

*Vinyl Wallcovering at Lavatory

HVAC:

Temperature/Humidity:	
Summer:	78° F, Max. 50% RH
Winter:	72° F, Min. 30% RH
Min. Air Changes/Hour:	N/A
Min. % Outside Air:	As per ASHRAE Std 62
Pressure:	N/A
Noise Criteria:	Max. 40 NC

Electrical:

Lighting Levels:	
Gen. Illum:	20 fc
Task Illum:	N/A
Over Bed:	N/A
Emergency	
Egress:	1 fc Ave.
Emergency Power:	
Medical Gases:	N/A
Night Lights:	Y
Vanity Light:	N/A
One Receptacle	
per PBPU:	N/A
Nurse Call:	Y

12. Holding Room - 81 NSF [7.5 m²]

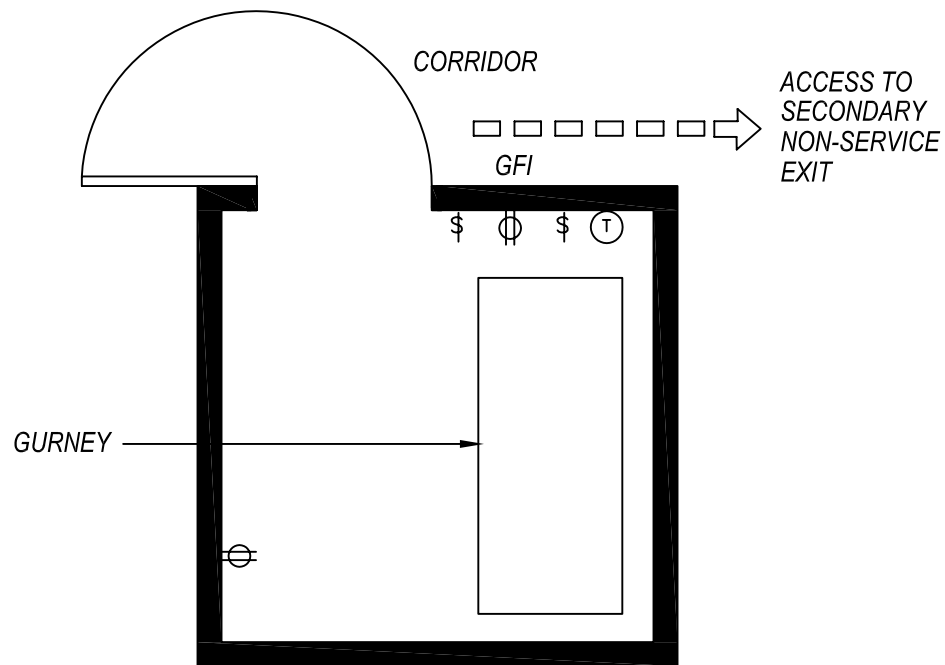
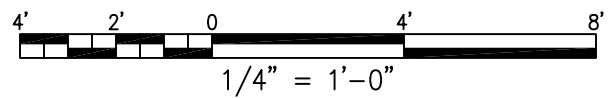

Figure 2.5.24



12. Holding Room Reflected Ceiling Plan

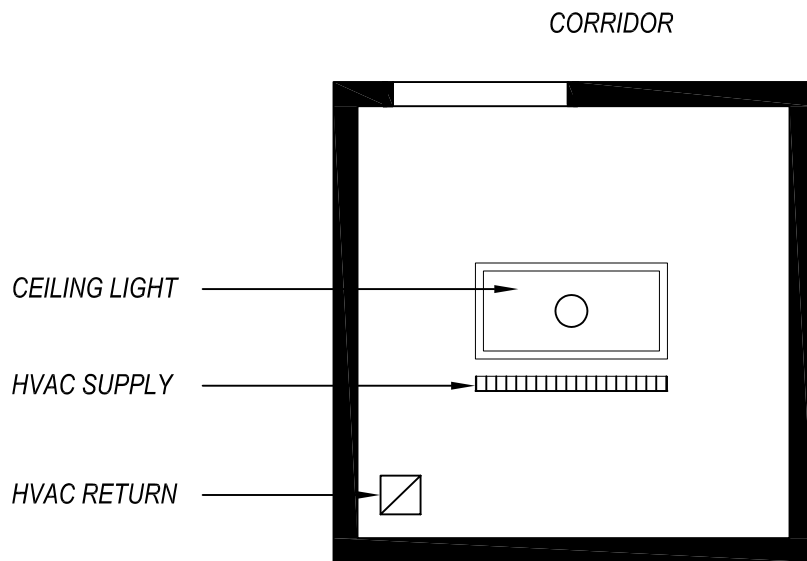
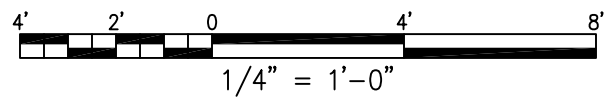

Figure 2.5.25



12. Holding Room

Function:

The holding room is used by unit staff for temporary storage of the deceased.

Space Requirement:

81 NSF [7.5 m²]

Architectural:

Finish Code:	1-A
Floor Finish:	Vinyl Composition Tile
Base:	Vinyl
Wall Finish:	Gypsum Wallboard
Ceiling:	Gypsum Wallboard
Ceiling Height:	9'-0"
Noise (STC Rating):	35
Slab Depression:	None
Special Construction:	-
Hardware:	23
Doors:	4'-0" x 7'-0" wood or metal.
Windows:	

HVAC:

Temperature:	
Summer:	
Winter:	
Min. Air Changes/Hour:	
Min. % Outside Air:	
Pressure:	
% Filtration:	
Noise Criteria:	
A/C Loads:	
Lights:	
Equipment:	
People:	

Electrical:

Lighting Levels:	
Gen. Illum:	30 fc
Task Illum:	N/A
Over Bed:	N/A
Emergency	
Egress:	N/A
Emergency Power:	
Medical Gases:	N/A
Night Lights:	N/A
Vanity Light:	N/A
One Receptacle	
per PBPU:	N/A
Nurse Call:	N/A

13. Main Entrance & Canopy

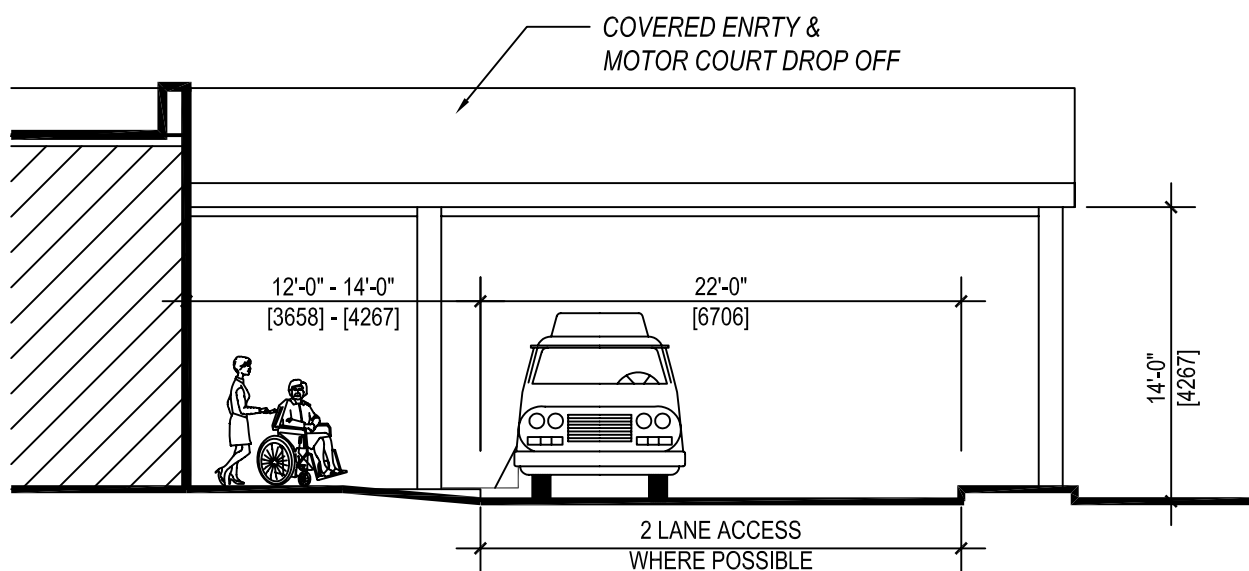
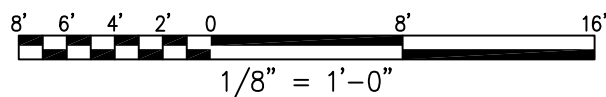

Figure 2.5.26



REFERENCES

Site Considerations

McCourt PE PTOE, Ransford S. **Parking Generation, 3rd Edition.** Institute of Transportation Engineers. (2004)

Perkins, Hogleung, King, Cohen. **Building Type Basics for Senior Living.** John Wiley & Sons, Inc. (2004)

Ramsey/Sleeper, The American Institute of Architects. **Architectural Graphic Standards, 9th Edition.** John Wiley & Sons, Inc. (1994)

Regnier FAIA, Victor. **Design for Assisted Living.** John Wiley & Sons, Inc. (2002)

Watson, Donald ; Crosbie, Michael J. ; Hancock Callender, John. **Time-Savers Standards for Architectural Data, 7th Edition.** McGraw-Hill (1997)

Perception and Interiors

American Institute of Architects. **Guidelines for Design and Construction of Hospital & Health Care Facilities 2001**

Briggs, Jenny. **Dementia Care and the Built Environment: Position Paper 3.** Alzheimer's Australia. June 2004

Canter Ph. D., David. **Psychology for Architects.** Halsted Press for John Wiley & Sons, Inc. (1974)

Gordon, Gary. **Interior Lighting for Designers, 4th Edition.** John Wiley & Sons, Inc. (2003)

Karten, Mark; Benya, James. **Lighting Design Basics.** John Wiley & Sons, Inc. (2004)

McCourt PE PTOE, Ransford S. **Parking Generation, 3rd Edition.** Institute of Transportation Engineers. (2004)

McGowen, Maryrose; Kruse, Kelsey. The American Institute of Architects. **Interior Graphic Standards.** John Wiley & Sons, Inc. (2004)

Perkins, Hogleung, King, Cohen. **Building Type Basics for Senior Living.** John Wiley & Sons, Inc. (2004)

Pile, John. **Color in Interior Design.** McGraw-Hill (1997)

Ramsey/Sleeper, The American Institute of Architects. **Architectural Graphic Standards, 9th Edition.** John Wiley & Sons, Inc. (1994)

Regnier FAIA, Victor. **Design for Assisted Living.** John Wiley & Sons, Inc. (2002)

Watson, Donald ; Crosbie, Michael J. ; Hancock Callender, John. **Time-Savers Standards for Architectural Data, 7th Edition.** McGraw-Hill (1997)