



NATIONAL AERONAUTICS AND SPACE ADMINISTRATION
WASHINGTON, D.C. 20546

REPLY TO
ATTN OF: GP

June 30, 1971

MEMORANDUM

TO: KSI/Scientific & Technical Information Division
Attn: Miss Winnie M. Morgan

FROM: GP/Office of Assistant General
Counsel for Patent Matters

SUBJECT: Announcement of NASA-Owned U.S. Patents in STAR

In accordance with the procedures contained in the Code GP to Code USI memorandum on this subject, dated June 8, 1970, the attached NASA-owned U.S. patent is being forwarded for abstracting and announcement in NASA STAR.

The following information is provided:

U.S. Patent No. : 3,202,398

Corporate Source : North American Aviation

Supplementary
Corporate Source : Rocketdyne Division

NASA Patent Case No.: XNP-00816

Please note that this patent covers an invention made by an employee of a NASA contractor. Pursuant to §305(a) of the NAS Act, the name of the Administrator of NASA appears on the first page of the patent; however, the name of the actual inventor (author) appears at the heading of Column No. 1 of the Specification, following the words ". . . with respect to an invention of. . . ."

Gayle Parker
Gayle Parker

Enclosure:
Copy of Patent

FACILITY FORM 602

N71-28928

(ACCESSION NUMBER)

3 (PAGES)

(NASA CR OR TMX OR AD NUMBER)

(THRU)

00 (CODE)

28 (CATEGORY)

Aug. 24, 1965

JAMES E. WEBB
ADMINISTRATOR OF THE NATIONAL AERONAUTICS
AND SPACE ADMINISTRATION

3,202,398

LOCKING DEVICE FOR TURBINE ROTOR BLADES

Filed Nov. 5, 1962

2 Sheets-Sheet 1

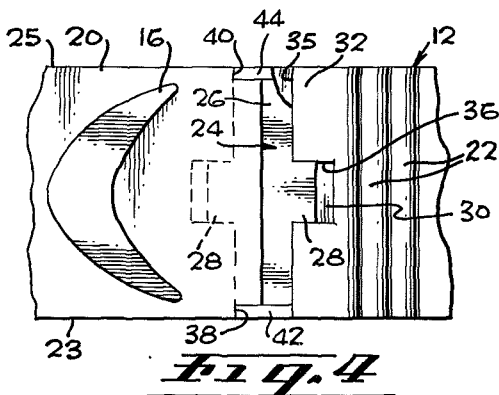
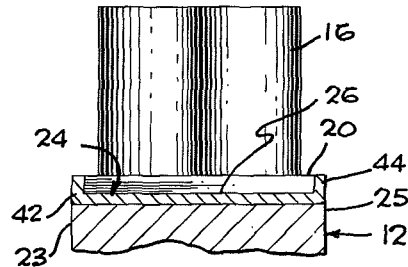
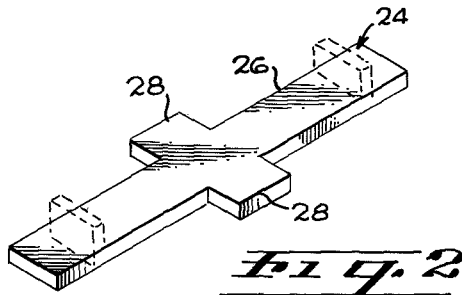
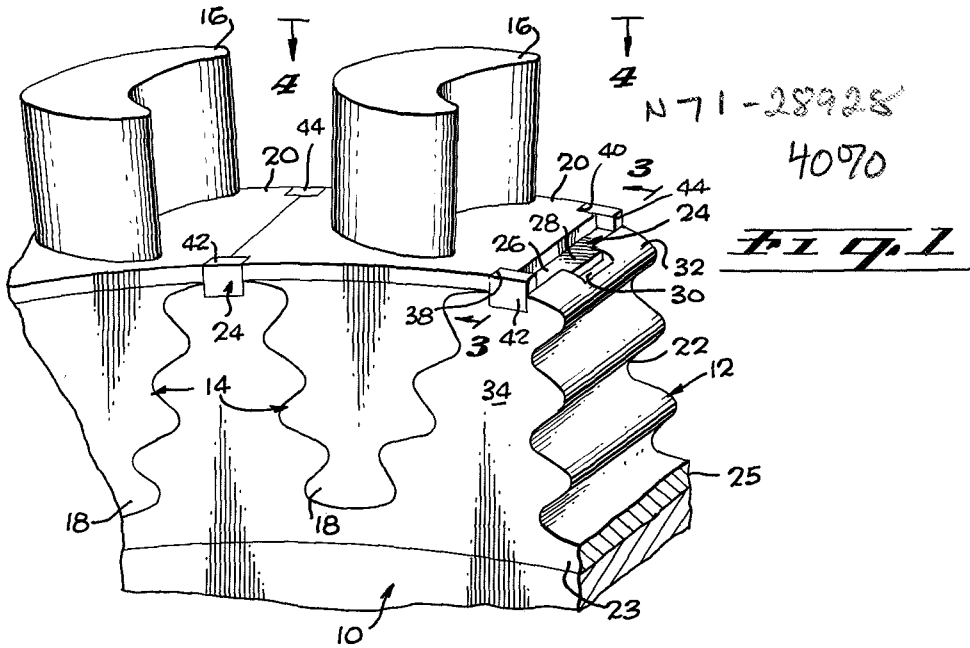

JOSEPH A. GOODRICH
KENNETH T. INGHAM
INVENTORS

BY *J. D. O'Brien*
Monte F. Matt

ATTORNEYS

1778

1

3,202,398

LOCKING DEVICE FOR TURBINE ROTOR BLADES

James E. Webb, Administrator of the National Aeronautics and Space Administration, with respect to an invention of Joseph A. Goodrich and Kenneth T. Ingham
Filed Nov. 5, 1962, Ser. No. 235,588
6 Claims. (Cl. 253-77)

The invention described herein may be manufactured and used by or for the Government of the United States of America for governmental purposes without the payment of any royalties thereon or therefor.

This invention relates to locking devices for turbine rotor blades such as are used in turbojet engines, axial flow compressors and the like, and more particularly the invention relates to a locking device or key which contributes to retaining a pair of turbine rotor blades on a turbine wheel.

It is an object of this invention to provide a locking device for turbine rotor blades which is engageable with a pair of adjacent or adjoining blades so as to contribute to retaining the adjoining blades on the turbine wheel.

Another object is to provide a locking device having a uniform geometrical configuration and is receivable in a complementary recess formed in the crown of a rotor projection so as to reduce or avoid introducing an unbalanced condition in the turbine rotor.

Another object of this invention is to provide a locking device of the character described wherein one of a pair of blade engaging tabs is considered adequate for contributing to the retaining of adjoining blades on the turbine wheel until such time as repairs can be performed in the event one of the tabs fails, and one of a pair of rotor wheel engaging tabs is considered adequate to retain the locking device in place.

Still another object of this invention is to provide a locking device of the character described wherein locking devices on each side of a central locking device will serve to retain adjoining blades on a turbine wheel until repairs can be performed in the event both pairs of tabs on the central locking device fail.

A yet further object of this invention is to provide a locking device of the character described wherein the locking device is economical to manufacture using non-critical materials, and is capable of being fabricated using mass production techniques.

These and other objects of the invention will become more apparent from a consideration of the description which follows, taken in conjunction with the drawings:

FIG. 1 is a fragmentary perspective view illustrating a portion of a turbine wheel employing one form of locking device of the present invention for retaining rotor blades in place.

FIG. 2 is a perspective view of a locking device embodying the present invention, the dotted lines illustrating the shape of the locking device after formation of tabs.

FIG. 3 is a sectional view, partially in elevation, taken on line 3-3 of FIG. 1.

FIG. 4 is an overhead view taken on line 4-4 of FIG. 1, parts being broken away to disclose details of construction.

FIG. 5 is a perspective view similar to FIG. 1, illustrating the use of another form of locking device employed to retain blades on a turbine wheel.

FIG. 6 is a perspective view of the locking device employed in FIG. 5, the dotted lines illustrating the shape of the locking device after formation of projections or tabs.

FIG. 7 is a sectional view, partially in elevation, taken on line 7-7 of FIG. 5.

2

FIG. 8 is an overhead view taken on line 8-8 of FIG. 5, parts being broken away to disclose details of construction.

The two forms of the invention are shown and described herein as applied to a typical turbine structure, and the structure hereinafter will be referred to as a turbine, but the term is not intended as one of limitation, since the invention is readily applicable to various machines of similar configuration.

Referring to FIGS. 1 and 5, there is illustrated a fragmentary portion of a turbine wheel 10 including the rim 12, the central portion of the wheel not being illustrated since it may follow any suitable known configuration, and the invention is not concerned with the disk or hub of the wheel. Blades 14 are mounted in the wheel, each blade comprising an airfoil or blade portion 16, a root 18, and a substantially rectangular or square blade platform 20, projecting circumferentially of the wheel immediately adjacent the rim thereof, between the blade portion and root portion of the blade. As illustrated, the blade roots are of the common multiple dovetail form and are mounted in the multiple serrated grooves 22 in the rim of the wheel. It is to be understood that the particular slot and root form is immaterial. These grooves 22 extend across the rim from the forward face 23 of the wheel to the rearward face 25 thereof. The blades are mounted by sliding them axially of the wheel into the grooves to thereby lock the blades against radial displacement.

The blade retaining or locking means illustrated in FIGS. 1-4 of the present invention comprises a relatively flat key 24 having a generally cruciform configuration which includes an elongated leg 26 and a pair of opposed substantially identical arms or projections 28 perpendicular to leg 26. Thus it may be seen that the key is generally geometrically symmetrical. That is, by symmetrical it is meant that the key can be divided by a plane into similar halves. For example in FIG. 2 a plane that is perpendicular to the key's longitudinal axis and that passes through the center of gravity of the key, will divide the key into two similar halves. Also, a plane containing the longitudinal axis of the key and that passes through the center of gravity of the key, will divide it into two similar halves about that plane.

Cruciform key 24 is receivable in a complementary recess 30 formed in the crown 32 of each rotor or wheel projection 34 with leg 26 being lodged in an elongated channel 35 which is axially disposed with respect to the axis of rotor wheel 10. Arms 28 are lodged in channels 36 which intersect and are perpendicular to channel 35 and which are circumferentially disposed with respect to the circumference of rotor wheel 10. When each key 24 is properly installed in the corresponding recess 30 it is disposed under a pair of substantially abutting adjacent or adjoining blade platforms 20 which prevent radial dislodgement of the key during rotation of the turbine wheel, and arms 28 of each key being lodged in channels 36, prevent the axial dislodgement of the key.

The symmetry of the keys 24 and recesses 30 reduce, if not entirely eliminate, the possibility of introducing an unbalanced condition in the rotor or turbine wheel 10, when the keys are employed for retaining the turbine blades 14 on the rotor wheel 10. When each key 24 is installed in the aforementioned manner it contributes to the retention of a pair of adjoining blades 14.

Each blade platform 20 is quadrilateral and has a notch in each corner thereof, and when the blades are installed with the notches of each blade platform registering with notches of the adjoining blade platform a forward notch 38 and a rear notch 40 are provided which receive a forward upturned tab or projection 42 and a rear up-

turned tab or projection 44 respectively, the tabs being disposed on the terminal ends of leg 26. The circumferential length of notches 38 and 40 is substantially equivalent to one-half the width of the corresponding tab, and the axial depth of notches 38 and 40 is substantially equivalent to the thickness of each corresponding tab. As a result the tabs 42 and 44 are disposed within the corresponding notches so that aerodynamic interference or turbulence is not created during rotation of the turbine wheel.

Originally, leg 26 is made long enough so that the length of the tabs 42 and 44, when formed, is more than adequate for completely engaging the blade platforms. After the tabs are formed, they are trimmed so that the terminal edge of each tab is in substantially the same plane as the upper surface of the blade platform. Thus, it may be seen that the tabs, in combination with the arms 23, prevent axial movement of blades 14.

In the event either one of the tabs 42 or 44 fails on one of the keys 24, the tab remaining will contribute to retaining the respective blades on the turbine wheel, until such time as repairs can be performed, and in the event both tabs of a single key are lost, the keys on each side of the damaged key will contribute to retaining the corresponding blades on the turbine wheel until such time as repairs become convenient.

Because of the width of each arm 23, there is little likelihood that either one or both of the arms 23 can be sheared from leg 26 under normal usage. However, if one arm 23 is sheared from leg 26, the opposite arm will retain the key 24 in the recess 30 until such time as it is convenient to replace the damaged key.

FIGS. 5-8 inclusive, illustrate another form of key 50 which, initially, comprises a pair of substantially identical L-shaped members 52 which preferably are welded, brazed, or otherwise fastened together with the upturned short leg or tab 54 of each member being in abutting relationship with the adjoining short leg or tab of the opposite member. When parts 52-52 are assembled as shown in FIG. 6, the entire assembly looks like a T lying on its back with the central "leg or stem" (tabs 54) facing upwardly. However, it is to be understood that members 52 need not be fastened together, but instead can be employed as separate members which in combination provide single key 50. The key shown in FIG. 6 is symmetrical in a manner like that of the key shown in FIG. 2. That is, a plane that is perpendicular to the key's longitudinal axis and that passes through the center of gravity of the key, will divide it into two similar halves; and a second plane containing the longitudinal axis of the key and that also passes through its center of gravity will also divide it into two similar halves about that plane (note the two Z shaped cross sections of each half in FIG. 7).

The crown 32 of each turbine wheel projection 34 has an elongated axial channel or recess 56 in a circumferential plane which is complementary to and receives key 50 which when installed is in underlying relationship to a pair of adjoining, substantially abutting blade platforms 20, the platforms preventing the keys from being thrown radially from turbine wheel 10 during rotation thereof. Each end 58 of each blade platform has a notch therein which is disposed substantially midway between the forward and the rear edges 60 and 62 respectively. With the notches of adjoining blade platforms in register, a relatively large notch 64 is provided which receives abutting legs 54 of members 52. The upper edge of each leg 54 when properly trimmed is in substantially the same plane as the upper surface of blade platform 20. The blades and key locks are all assembled at one time onto the turbine wheel. That is, any type of a jig can be provided that will support the blades with keys in place in a circle. The blades and keys can then all be slid off the jig and onto the turbine wheel at the same time, in the way that a piston ring would be slipped onto a piston.

After installation of the keys 50 and blades 14 on the turbine wheel 10, each relatively long leg 66 of each member has a down turned tab 68 formed thereon which is received in a complementary recess in the respective surface of turbine projection 34, the tabs being flush with the surface of the projection 34 so that the aforementioned turbulence and interference does not occur.

The combination of downturned tabs 62 and upturned legs 54 prevent axial movement of turbine blades 14.

The loss of a single leg, tab or projection 54 of a single key 50 will not adversely affect the operation of the turbine wheel since the opposite tab of the key will assist in retaining the respective blades on the wheel 10 until repairs can be performed, and the loss of both tabs 54 of a single key 50 will not require taking the turbine out of operation, for the keys 50 on each side of the damaged key will retain the blades on the turbine wheel until repairs are convenient to make. With respect to performing repairs and the like, the same thing holds true with respect to the loss of tabs or projections 68 as holds true with respect to tabs 54.

While the present invention has been described herein in what is considered to be preferred embodiments thereof, it should be recognized that departures may be made therefrom within the scope of the invention, and it should therefore not be limited to the details of the disclosure, but should be accorded the full scope of the appended claims.

What is claimed is:

1. A turbine rotor having axial spaced opposite faces, spaced, axially extending peripherally dovetailed grooves therein defining projections between the adjacent grooves, each of said projections having an axial channel in the peripheral surface thereof extending to the opposite axial faces of the rotor, said channels having identically opposed circumferentially extending recesses communicating with each of said channels, blades having dovetailed groove projections interengaging said dovetailed grooves in said rotor and having circumferentially extending platforms overlying said projections and the channels and recesses therein, each of said platforms having axially spaced ends terminating in the corresponding plane of the axial opposed ends of the rotor, a recess in each end of the said platform overlying said projections and the channels therein and complementary to said channels, a key in each of said channels having projections thereon fitting the identically opposed recesses and underlying said platforms, and a projection in each end of said key fitting the recesses in each end of the platform to prevent the blades from being axially displaced from the rotor.

2. A turbine rotor having axially spaced opposite faces, axially extending peripheral grooves therein defining projections between the adjacent grooves, each of said projections having an axial channel in the peripheral surface thereof extending to the opposite axial faces of the rotor, said channel having a smooth bottom surface lying in a circumferential plane, blades having portions interengaging with said grooves in said rotor to prevent radial displacement of said blades, said blades having circumferentially extending platforms overlying said projections and the channels, each of said platforms having axially spaced ends, recesses in each of said platforms overlying said projections and the channels therein, a key having a longitudinal axis and being symmetrical about a plane that passes through the center of gravity of said key and perpendicular to the longitudinal axis, said key having a smooth undersurface portion thereof complementary to and receivable in said channel, and prevented by the walls of said channel from being displaced circumferentially, said portion of the key and complementary channel being symmetrical so as to avoid introducing an unbalanced condition in said turbine rotor when the blades are installed in position, a projection on said key engaging said rotor projection to prevent displacement of said key, and

5

a tab on said key engaging adjoining blade recesses to prevent axial displacement of said adjoining blades.

3. A turbine rotor having axially spaced opposite faces, spaced, axially extending peripheral grooves therein defining projections between the adjacent grooves, each of said projections having an axially cruciform channel in the peripheral surface thereof extending between the opposite axial faces of the rotor, blades having portions interengaging with said grooves in said rotor to prevent radial displacement of said blades, said blades having circumferentially extending platforms overlying said projections and the channels, each of said platforms having axially spaced ends, a recess in each of said platforms overlying a projection and the channel therein, a substantially flat cruciform key having a configuration complementary to and receivable in said channel, and underlying a pair of adjoining blades, the arms and legs of said cruciform key laying in the same circumferential plane, the arms of said cruciform key preventing displacement of said key, and said cruciform key having a tab on each terminal end of the leg of said key which engages said adjoining blades to prevent displacement of said adjoining blades axially and circumferentially.

4. A device as set forth in claim 3 wherein each of said blades have a platform that is quadrilateral and said recesses are in each corner of the platform so that when said blades are in adjoining relationship, the recesses of the adjoining blades are in registry so as to receive said tabs which are recessed therein to thereby provide a smooth surface which substantially prevents generation of resistance and turbulence during rotation of the blades.

6

5. A construction according to claim 2 wherein each of said blades have recesses therein disposed intermediate the axially spaced ends of each of said blade platforms, and that are in registration to receive said tab when said blades are in adjoining relationship.

6. The device as set forth in claim 2 wherein said key comprises two Z-shaped members in end-to-end relation to provide a pair of tabs that are in abutting relationship, and wherein said blades each include a blade platform having recesses therein disposed intermediate the axially spaced ends of each of said blade platforms, and when said blades are in adjoining relationship said recesses are in registration to receive said pair of tabs.

References Cited by the Examiner

UNITED STATES PATENTS

| | | | | |
|-----------|-------|--------|-------|--------|
| 2,942,842 | 6/60 | Hayes | ----- | 253—77 |
| 3,157,385 | 11/64 | Jensen | ----- | 253—77 |

FOREIGN PATENTS

| | | |
|---------|------|----------------|
| 671,960 | 5/52 | Great Britain. |
| 715,837 | 9/54 | Great Britain. |

OTHER REFERENCES

German printed application No. 1,032,753, June 26, 1958.

DONLEY J. STOCKING, *Primary Examiner.*

JOSEPH H. BRANSON, JR., KARL J. ALBRECHT,
HENRY F. RADUAZO, *Examiners.*