



The Challenges of Developing a Food System for a Mars Mission



*Michele Perchonok, Ph.D.
Advanced Food Technology Project Manager
Shuttle Food System Manager
NASA/JSC*





www.nasa.gov

*We're not where we want to be
We're not where we are going to be
BUT, we're certainly not where we
were yesterday.*

The NASA Vision

To improve life here,
To extend life to there,
To find life beyond.

The NASA Mission

To understand and protect our home planet,
To explore the universe and search for life,
To inspire the next generation of explorers
... as only NASA can.

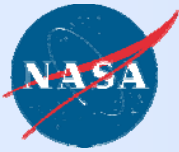

The President's Vision for U.S. Space Exploration - January 14, 2004

- Return the **Shuttle** to flight as soon as possible in order to complete the construction of the International Space Station
- Focus U.S. research and use of the **International Space Station** on supporting space exploration goals, with emphasis on understanding how the space environment affects **astronaut health** and capabilities and developing countermeasures
- Implement a sustained and affordable **human and robotic** program to explore the solar system and beyond
- Extend human presence across the solar system, starting with a human return to the **Moon by the year 2020**, in preparation for human exploration of Mars and other destinations
- **Mars** and other destinations
 - Conduct **robotic** exploration of Mars to search for evidence of life, to understand the history of the solar system, and to prepare for future human exploration.
 - Conduct **human** expeditions to Mars after acquiring adequate knowledge about the planet using robotic missions and after successfully demonstrating sustained human exploration missions to the Moon

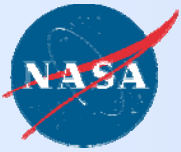

Introducing Orion (and Ares)

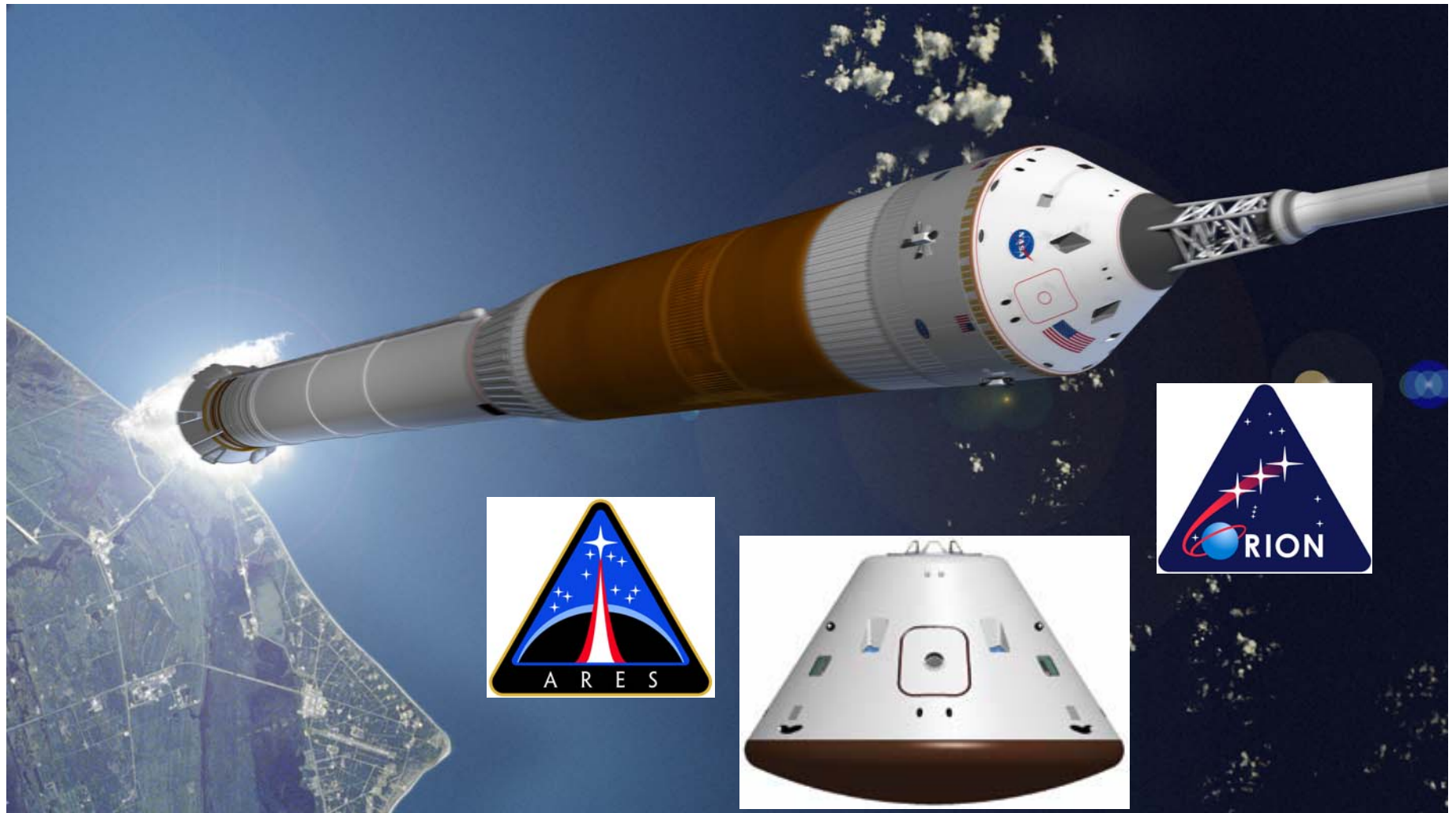

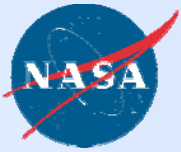

History and Present

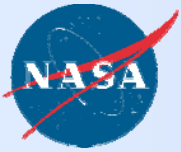

Mercury (1961 – 1963)

■ Objective

- To orbit a manned spacecraft around Earth
- To investigate man's ability to function in space
- To recover both man and spacecraft safely

■ Food System

- Highly engineered foods (Meal in a Pill)
- Tube food (not seen or smelled/ unacceptable texture)
- Cubes: (no change in flavor, texture: unlike original product)
- No crumbs



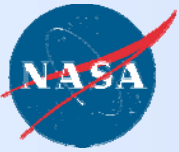

Gemini (1965 – 1966)

- Objective
 - To subject men and equipment to space flight up to 2 weeks in duration
- Food System
 - Highly engineered foods (Meal in a Pill)
 - More variety
 - Shrimp cocktail
 - Chicken and vegetables
 - Butterscotch pudding
 - Applesauce

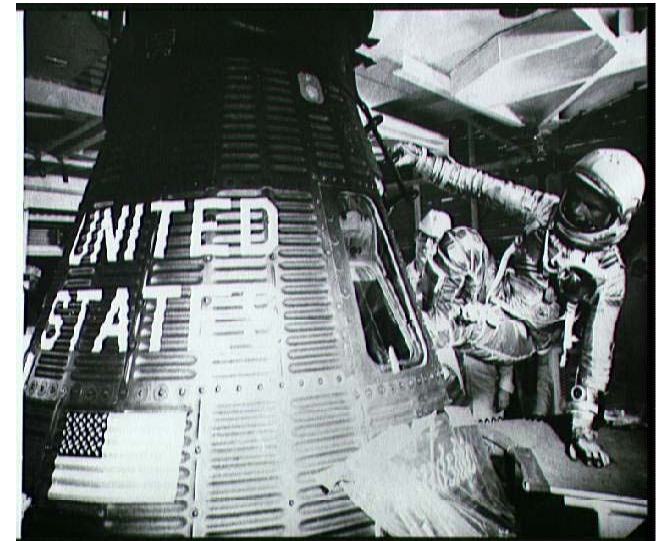

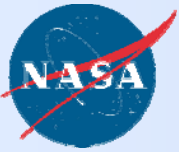

Apollo (1968 – 1972)

■ Objective

- To land Americans on the Moon and return them safely to Earth

■ Food System

- Improved packaging with improved quality
- Intermediate Moisture Food/
Natural Form
Ready-to Eat
- Thermostabilized: flexible packages, aluminum cans
- First to use “spoon bowl” – container that is opened and contents eaten with a spoon

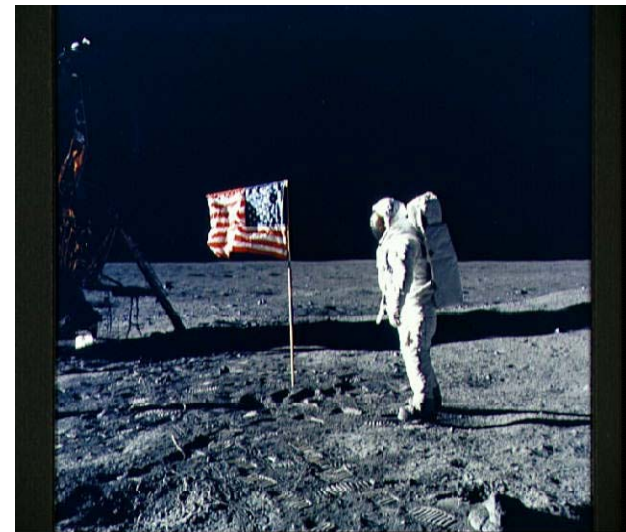

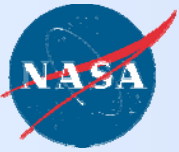

Skylab (1973 – 1974)

- First space station with a laboratory
 - Food stored at time of initial launch; no chance for resupply
 - Ready to eat, rehydratable foods
 - Precooked, thermally stabilized or fresh food
 - Beverages: collapsible plastic accordion-like dispensers
 - Pre-cooked or fresh food kept frozen





Shuttle/Mir (1995-1998)

- Typical Russian Space Menu Plan
- 6 Day cycle, 4 meals per day
- Half Russian, half U.S. meals
- Shuttle food warmer used to heat U.S. food
- Shuttle drinking water containers used
- U.S. condiments
- Delivered to Mir by Shuttle and Progress
- **9 month shelf life**



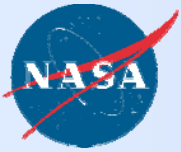

Shuttle (1981-present)

International Space Station (2000 –present)

- Foods are individually packaged
- All foods are preprocessed (except fresh foods)
 - Thermostabilized
 - Dehydrated/Freeze dried
 - Intermediate moisture
 - Natural form
 - Irradiated to commercial sterility
- Some fresh foods available for early part of mission
- Stored at ambient temperature
- ISS – 50% US/50% Russian
- Freeze-dried, intermediate moisture, and natural form foods overwrapped to maintain **12 – 18 month shelf life**

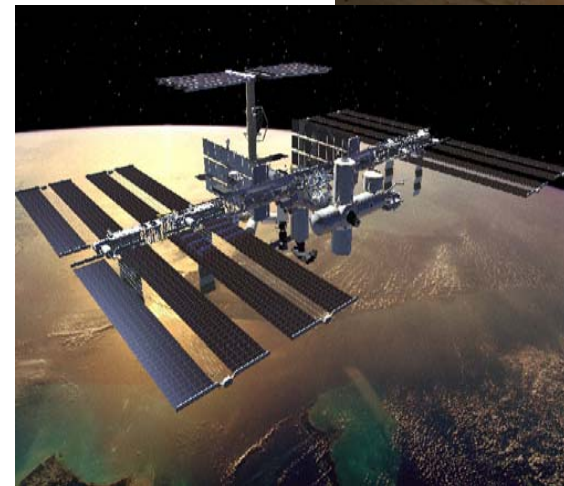



NASA Packaged Food Items



**Intermediate
Moisture**



**Thermostabilized
or Irradiated**



**Natural
Form**



Freeze-dried



Beverage

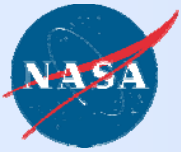

Future

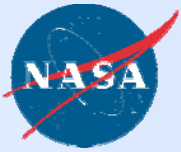

Advanced Food Technology

Goals and Objectives

- Provide an adequate food system
 - Develop a safe food system
 - Develop a nutritious food system
 - Develop an acceptable food system
- Provide an food system that efficiently balances vehicle resources
 - Minimize volume
 - Minimize mass
 - Minimize waste
 - Minimize power
 - Minimize trace gas emissions
 - Minimize crew time

The goals and objectives of AFT are at odds with one another



- Example: To maintain an adequate food system may require more packaging mass which conflicts with minimize mass.



Advanced Food Technology

- The food system will initially emphasize technologies for space vehicle applications (ISS and Shuttle) then slowly increase focus on technologies toward tasks that support exploration.
- Assumption: There are **psychological benefits** of the food system and plants
 - Socialization during mealtimes
 - **Food quality, variety and acceptability** are important and encourage eating a well-balanced diet. Highly acceptable food is a familiar element in an unfamiliar and hostile environment, especially important as mission durations increase.
- Nutrition
 - Menus must provide adequate nutrition for long duration missions
 - Start with USRDI and then make adjustments to compensate for affects from long duration space mission
 - Higher calcium
 - Lower iron
 - Lower sodium
 - TBD

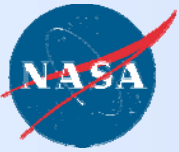

Orion Missions

- Orion will dock with International Space Station (ISS)
– 2 weeks duration - 2014
- Lunar Sortie – 2-3 weeks duration - 2019
- Lunar Outpost – 6 month missions – 2022
- Mars Missions – 3 years - ???



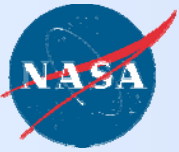

Orion Challenges

- Habitable volume is very limiting and significantly less than Shuttle and International Space Station (ISS)
- Limited volume requires a different way of thinking
 - Galley questions
 - Hot, cold, ambient water?
 - Food warmer
 - Food system
 - Can we use a combination of nutrient dense foods and ISS food?
 - Can we find another way to stow the food?
 - How much water does the crew actually need?
 - Can we reduce the mass/volume of the food system?
 - Nutritional and Psychological Requirements for a “camping trip”
 - How willing will the crew be to compromise the food system?



Food Packaging

- Current packaging
 - Thermal and irradiated packaging – multilayer including a foil layer
 - Excellent barrier properties to oxygen and water
 - Foil difficult to process when waste
 - Foil is more dense (heavier)
 - Natural form, freeze-dried, etc. – poly multilayer which requires overwrap for ISS to maintain shelf life of 12 months
- Exploration mission packaging
 - Develop packaging material with **EXCELLENT barrier properties without the foil layer** and without increasing mass
 - Consider bio-degradable, compactable, reusable packaging to minimize solid processing
 - Compatible with processing and storage conditions
- Needed for longer duration missions

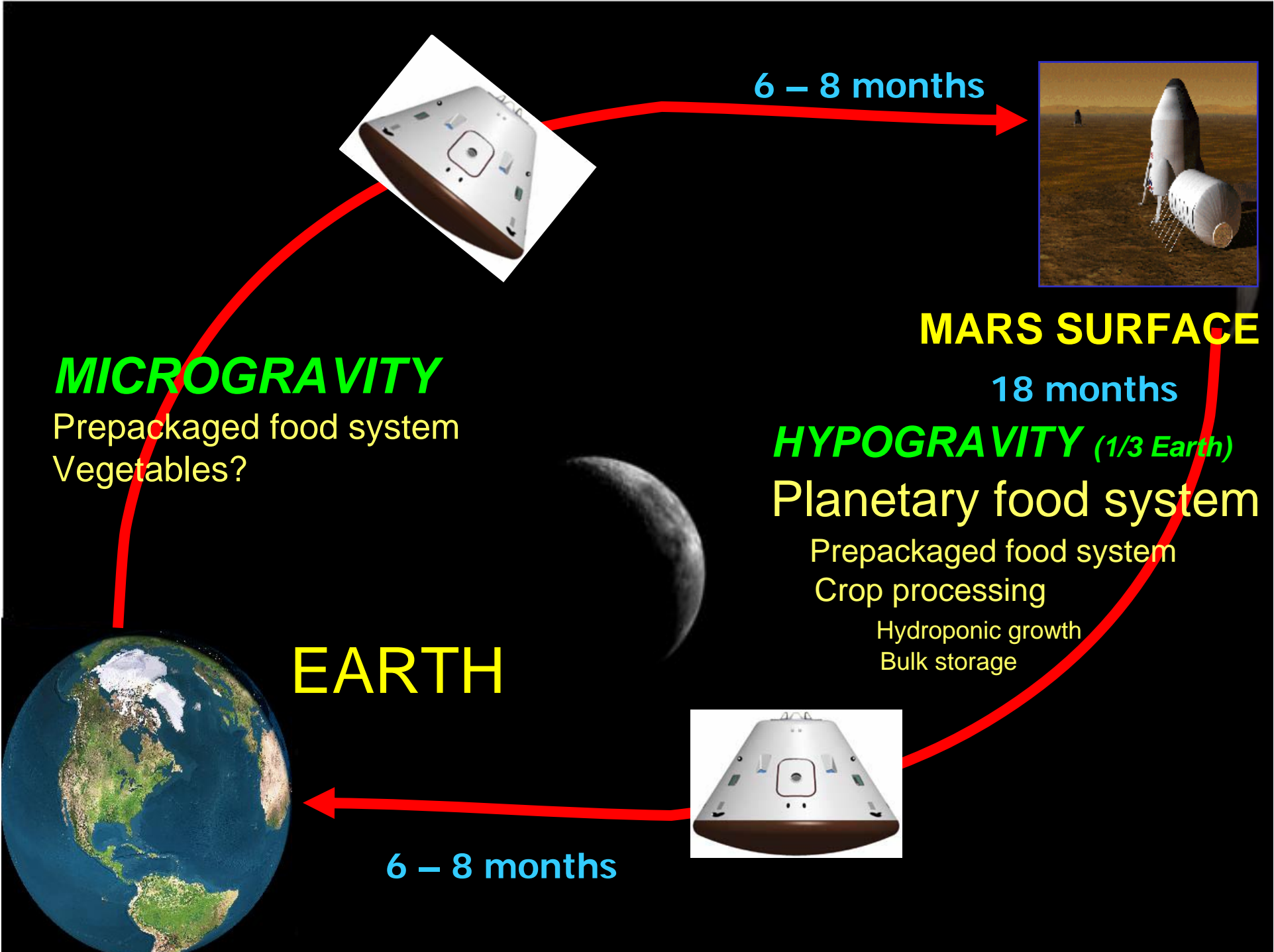

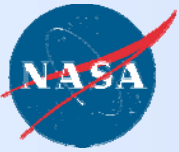

Mars Mission Assumptions

- Transit food system will be stored food system
 - Require 3 – 5 year shelf life
 - No food preparation
 - 0G
 - Mass of transit food system for a Mars Mission has been estimated to be **9660kg**. Packaging waste is **1440kg** of this mass. (Assumes 100% stored food for 1000 days for a crew of 6)
- Surface habitat food system - **Combination of a bioregenerative and stored food system**
 - Food processing
 - Food preparation in galley
 - Reduced atmosphere pressure (≥ 8 psia)
 - 3/8G

} → **Results in significant crewtime**
- Will have little or no resupply options
- Total radiation dose for 3 year mission could be as high as 3 grey.
 - Food will likely be in an unprotected area
 - Food may be used for radiation shielding
 - Antioxidants within the food may be a potential countermeasure for radiation

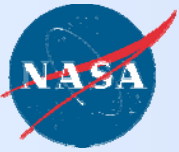

Planetary Food System Selected Crops

Salad Crops

- Tomato
- Carrot
- Spinach
- Cabbage
- Green Onion
- Lettuce
- Radish
- Herbs
- Bell Pepper
- Strawberry

CAN BE USED FRESH

Other crops

- Potato
- Sweet potato
- Wheat
- Soybeans
- Peanut
- Rice
- Dried beans

NEED PROCESSING



Food Processing Equipment Constraints

- **Water and Energy Limitations**
 - Limited water for processing and cleaning - consider recycling of water during processing to capture lost nutrients
 - Restricted power for food processing and cleaning
- **Waste and Contamination Concerns**
 - Waste water processing time
 - Restricted power
 - Competitive bacterial contamination of water processing system



Crew Involvement Constraints

- Time Constraints
 - Maximize exploration time
 - Minimize daily task time
 - Ease of cleaning
 - Ease of assembly/disassembly
- Automation Constraints
 - Saves time
 - Technologically intensive
 - In case of power failure, is there a simple procedure for manual override?

WHEAT



harvest

seeds



starch

starch/gluten separator

gluten

seitan

bread

flour

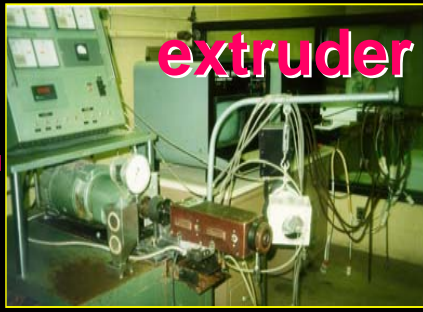

cereal

snacks

pasta



growth

harvest

seeds

+ water

Meat
Analog + Oil

Okara

fiber



Soy milk

Tofu + Whey

Soy



Advanced Food Technology Integration

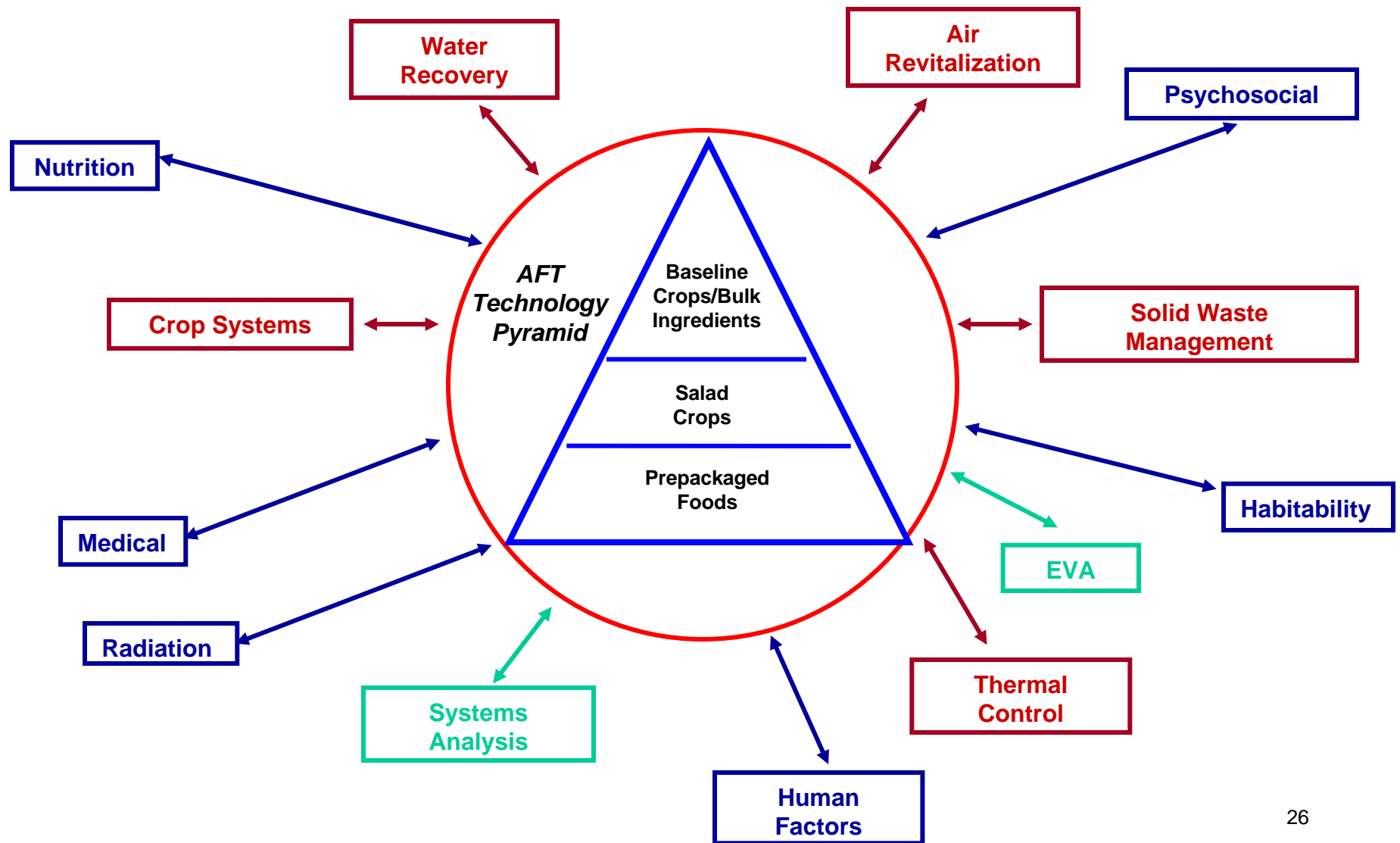

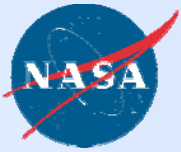

Current Research



Research Highlights – Internal

- Accelerated shelf life testing
 - Thermostabilized pouches
 - Three year test at 40°F, 72°F and 95°F; sample every 4 – 6 months
 - Four items completed; 8 items still in test
 - Bulk Ingredients
 - Cocoa powder, dried egg whites, corn starch
 - Three year test at 40°F, 72°F and 95°F; sample every 4 – 6 months
- CEV Galley Trade Studies
 - Hydration at ambient temperature instead of hot or cold temperature
 - Twenty items on list to test for sensory differences
- Effect of processing on nutrition
 - 10 items per year
 - Nutrition prior to processing, after processing, at 1 year and 3 years
- Packaging Shelf Life Study
 - Three packaging materials
 - 3 year
 - Cottonseed oil, peanuts, Cheerios
 - Trained sensory panelists
 - Measure oil rancidity and moisture pickup
- Packaging Workshop
 - 20 participants

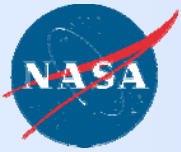

Research Highlights – External

- Effects on soybeans, wheat berries, and oils at varying levels of radiation
 - Ability to produce tofu from soybeans (Lester Wilson – Iowa State University)
 - Oil and wheat (Lisa Mauer – Purdue University)
 - Rennet enzyme – affects on cheese curd development (Lester Wilson – Iowa State University)
- Reheating and Sterilization Technology for Food, Waste and Water (Sudhir Sastry – Ohio State)
 - Uses ohmic heating for heating or sterilizing individual packages
- A Multipurpose Fruit and Vegetable Processing System for Advanced Life Support (R. Paul Singh – UC Davis)
 - Using tomatoes for testing

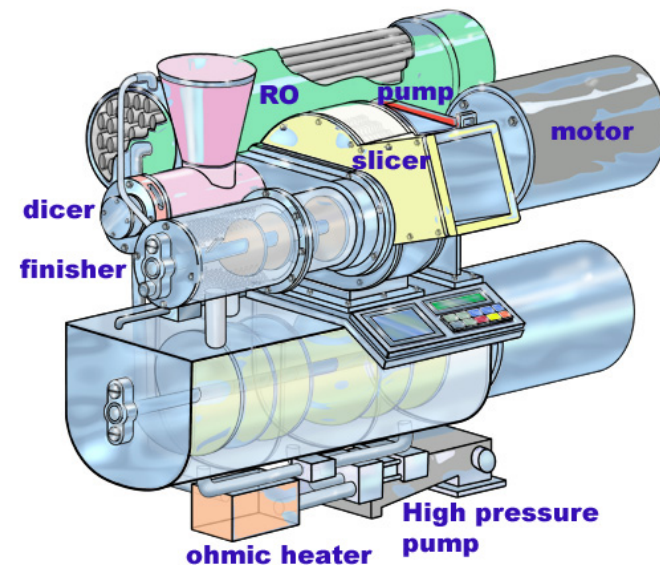

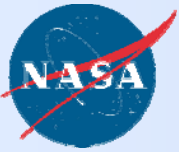

Thank you!



<http://hefd.jsc.nasa.gov/aft.htm>

Questions?

Discovery Launch July 2005