

NASA/TM—2003-212455



Reference Gauging System for a Small-Scale Liquid Hydrogen Tank

Neil T. Van Dresar
Glenn Research Center, Cleveland, Ohio

James D. Siegwarth
National Institute of Standards and Technology, Boulder, Colorado

The NASA STI Program Office . . . in Profile

Since its founding, NASA has been dedicated to the advancement of aeronautics and space science. The NASA Scientific and Technical Information (STI) Program Office plays a key part in helping NASA maintain this important role.

The NASA STI Program Office is operated by Langley Research Center, the Lead Center for NASA's scientific and technical information. The NASA STI Program Office provides access to the NASA STI Database, the largest collection of aeronautical and space science STI in the world. The Program Office is also NASA's institutional mechanism for disseminating the results of its research and development activities. These results are published by NASA in the NASA STI Report Series, which includes the following report types:

- **TECHNICAL PUBLICATION.** Reports of completed research or a major significant phase of research that present the results of NASA programs and include extensive data or theoretical analysis. Includes compilations of significant scientific and technical data and information deemed to be of continuing reference value. NASA's counterpart of peer-reviewed formal professional papers but has less stringent limitations on manuscript length and extent of graphic presentations.
- **TECHNICAL MEMORANDUM.** Scientific and technical findings that are preliminary or of specialized interest, e.g., quick release reports, working papers, and bibliographies that contain minimal annotation. Does not contain extensive analysis.
- **CONTRACTOR REPORT.** Scientific and technical findings by NASA-sponsored contractors and grantees.

- **CONFERENCE PUBLICATION.** Collected papers from scientific and technical conferences, symposia, seminars, or other meetings sponsored or cosponsored by NASA.
- **SPECIAL PUBLICATION.** Scientific, technical, or historical information from NASA programs, projects, and missions, often concerned with subjects having substantial public interest.
- **TECHNICAL TRANSLATION.** English-language translations of foreign scientific and technical material pertinent to NASA's mission.

Specialized services that complement the STI Program Office's diverse offerings include creating custom thesauri, building customized databases, organizing and publishing research results . . . even providing videos.

For more information about the NASA STI Program Office, see the following:

- Access the NASA STI Program Home Page at <http://www.sti.nasa.gov>
- E-mail your question via the Internet to help@sti.nasa.gov
- Fax your question to the NASA Access Help Desk at 301-621-0134
- Telephone the NASA Access Help Desk at 301-621-0390
- Write to:
NASA Access Help Desk
NASA Center for Aerospace Information
7121 Standard Drive
Hanover, MD 21076

NASA/TM—2003-212455



Reference Gauging System for a Small-Scale Liquid Hydrogen Tank

Neil T. Van Dresar
Glenn Research Center, Cleveland, Ohio

James D. Siegwarth
National Institute of Standards and Technology, Boulder, Colorado

National Aeronautics and
Space Administration

Glenn Research Center

July 2003

Available from

NASA Center for Aerospace Information
7121 Standard Drive
Hanover, MD 21076

National Technical Information Service
5285 Port Royal Road
Springfield, VA 22100

Available electronically at <http://gltrs.grc.nasa.gov>

Reference Gauging System for a Small-Scale Liquid Hydrogen Tank

Neil T. Van Dresar
National Aeronautics and Space Administration
Glenn Research Center
Cleveland, Ohio 44135

James D. Siegwarth
National Institute of Standards and Technology
Boulder, Colorado 80305

Summary

A system to accurately weigh the fluid contents of a small-scale liquid hydrogen test tank has been experimentally verified. It is intended for use as a reference or benchmark system when testing low-gravity liquid quantity gauging concepts in the terrestrial environment. The reference gauging system has shown a repeatable measurement accuracy of better than 0.5 percent of the full tank liquid weight. With further refinement, the system accuracy can be improved to within 0.10 percent of full scale.

This report describes the weighing system design, calibration, and operational results. Suggestions are given for further refinement of the system. An example is given to illustrate additional sources of uncertainty when mass measurements are converted to volume equivalents. Specifications of the companion test tank and its multi-layer insulation system are provided.

Nomenclature

GHe	gaseous helium
GN ₂	gaseous nitrogen
m_a	applied mass, kg (lb)
m_{cal}	calibration mass, kg (lb)
m_f	fluid mass, kg (lb)
m_i	indicated mass (scale output), kg (lb)
U	uncertainty
V_c	correction to measured tank volume, m ³ (ft ³)
V_t	tank internal volume, m ³ (ft ³)
V_w	weighed tank volume, m ³ (ft ³)
α	calibration curve-fit constant (zero intercept), kg (lb)
β	calibration curve-fit constant (coefficient for applied mass)
γ	calibration curve-fit constant (coefficient for pressure difference), kg/kPa (lb/psi)
Δm_{GN_2}	mass of gaseous nitrogen added to tank, kg (lb)
ΔP	difference between tank pressure and pressure outside of tank, kPa (psi)
λ	liquid fill level, percent
ρ_{GHe}	density of gaseous helium, kg/m ³ (lb/ft ³)
$\rho_{GN_2,f}$	final density of gaseous nitrogen in tank, kg/m ³ (lb/ft ³)
$\rho_{GN_2,i}$	initial density of gaseous nitrogen in tank, kg/m ³ (lb/ft ³)
ρ_i	density of gas inside tank during calibration, kg/m ³ (lb/ft ³)

ρ_ℓ	liquid density, kg/m ³ (lb/ft ³)
ρ_v	vapor density, kg/m ³ (lb/ft ³)
σ	standard deviation

Introduction

NASA and its partners are examining a variety of technologies intended to gauge the quantity of cryogenic liquid remaining in a propellant tank in low-gravity. Examples are fluid compression gauging,¹⁻³ optical attenuation methods,^{4,5} injection of noncondensable pressurant gases,⁶ and radio frequency or acoustic attenuation methods.⁷⁻⁹ Prior to spaceflight testing of these various concepts, ground testing is performed to assess the potential of the various candidate methods. A key factor in evaluating the gauging methods is the accuracy of the methods. Other factors such as weight, power consumption, operational constraints, reliability and cost are also of importance. The preferred method of assessing gauging accuracy is to compare the test gauge results to a benchmark method or reference standard. The reference standard system should have an accuracy that is significantly better than the method under test.

The NASA Glenn Research Center (GRC) has a cryogenic vacuum chamber facility used for small-scale ground test programs. The National Institute of Standards and Technology (NIST) designed and built key components of a tank weighing system to be used as the reference standard for gauging tests in the GRC facility. The weighing system is specifically intended for use with a small test tank containing liquid hydrogen. This report describes the tank weighing system and its measurement capabilities.

Reference Gauging System Requirements

The maximum allowable collective uncertainty of measurement standards under ANSI/NCSL general requirements¹⁰ is 25 percent of the allowable tolerance. This can be interpreted as equivalent to a test accuracy ratio of 4:1 or more, meaning the tolerance of the parameter being tested is greater than or equal to four times the combination of the uncertainties of the measurement standard.¹¹

The design point for the reference gauging system is ten times better accuracy than the best accuracy expected from the methods to be tested. NASA's targeted accuracy for low-gravity cryogenic gauging is 1 percent of full scale (1 percent of the mass of liquid in a full propellant tank). The LH₂ test tank for gauging experiments at GRC has a volume of 0.16 m³ (5.6 ft³). If this tank were completely filled with saturated LH₂ at 101 kPa (14.7 psia) ($\rho_f = 70 \text{ kg/m}^3$ (4.4 lb/ft³)) the liquid would weigh about 11 kg (25 lb). The accuracy requirement for the small-scale reference system at GRC was thus specified as one-tenth of 1 percent of the full tank LH₂ weight or $0.1 \times 0.01 \times 11 \approx 0.011 \text{ kg}$ (0.025 lb) at a two-sigma (2σ) confidence level.

Since access to the GRC vacuum chamber requires removal of the chamber's lid, the test hardware must be assembled and attached to the underside of the lid while the lid is placed on a support fixture located to the side of the vacuum chamber. Once assembly is completed and the hardware is fully checked out, the entire lid and test hardware package is hoisted vertically, then laterally repositioned over the chamber and carefully lowered until the lid is seated. It is therefore required that the weighing system hardware must be suspended from the vacuum chamber lid and be able to withstand the forces and disturbances occurring when the test package is placed in the chamber. The system must operate in a hard vacuum environment. Output has to be transmitted to and displayed in a remote control room.

Reference Gauging System Design

A proven and commonly used tank gauging method in the terrestrial environment is direct weighing of the tank and its contents by either placing the tank on top of a scale or suspending the tank from underneath the scale. The suspended approach was chosen for the small-scale LH₂ tank reference gauging system. A counterbalance removes the tare weight of the tank. Since the tank is much heavier than the LH₂ contained within, counterbalancing the dry tank weight allows a substantial reduction of the range of the scale. The result is an increase in resolution in absolute terms that makes it possible to satisfy the accuracy requirement.

The bare LH₂ test tank mass is 140 kg (300 lb). Additional components, such as a pump, spray bar, multi-layer insulation, instrumentation and test hardware can result in a total dry tank/hardware mass in excess of 190 kg (420 lb). Therefore, the fluid mass is roughly only 5 percent of the total mass $\left(\frac{11}{190+11} \times 100\right)$ when the tank is full. Additional details about the tank, internal hardware and insulation are provided in appendix A.

If the test tank were fully supported by the load transducer, the required transducer full-scale range would be about 225 kg (500 lb) if a 35 kg (80 lb) margin is included. To achieve the required reference accuracy, the transducer resolution would have to be 0.005 percent of full scale. This level of resolution is not known to be available at an acceptable cost. However, if the empty tank weight is counterbalanced such that the load transducer senses only the weight of the fluid in the tank, it is possible to build a weighing system of relatively low cost. The load transducer for this system must have a resolution of 0.1 percent of full scale. This requirement can be readily met with inexpensive, off-the-shelf load sensors.

Figure 1 is a schematic diagram showing the major components and the overall design concept of the reference weighing system. The entire assembly fits within the vacuum chamber which is 1.8 m (6 ft) in diameter by 3.0 m (10 ft) high. The assembly is suspended from the vacuum chamber lid. A support structure attached to the vacuum chamber lid supports the balance arm at the arm's center pivot point. The test tank is suspended from a pivot at one end of the arm, while the counterweight is suspended from another pivot point at the opposite end. A scale (strain gauge balance) is located on a supporting platform above the balance arm at the tank end and is connected to the tank suspension pivot via a small flexible chain. When properly set up, the scale primarily senses only the weight of fluid in the test tank. The tank fill and vent lines are geometrically similar and are positioned on opposite sides of the balance arm. Each line has a short vertical section extending from the test tank lid, a horizontal section and a longer vertical section that extends to the vacuum chamber lid. Each line is fitted with three highly flexible gimbal joints—one in the short vertical section and one each near the top and bottom of the long vertical section. The purpose of the gimbal joints is to minimize transmission of external forces through the fill and vent lines that would distort the equilibrium of the balance system and introduce measurement error. The remaining major component is a subassembly of four calibration weights. This subassembly is located between the scale and the balance arm and is directly attached to the support structure above. The four calibration weights have mass ratios of 1:2:4:8, with the sum of the weights (12 kg (27 lb)) slightly exceeding the full-scale mass of LH₂ in the tank. The weights can be remotely and individually raised or lowered by pneumatically actuated lifting mechanisms. When lowered, the weights are supported and sensed by the scale. Sixteen different weight combinations allow calibration of the weighing system over the full range from no load to full load. Figure 2 is a photograph of the assembled weighing system and insulated test tank.

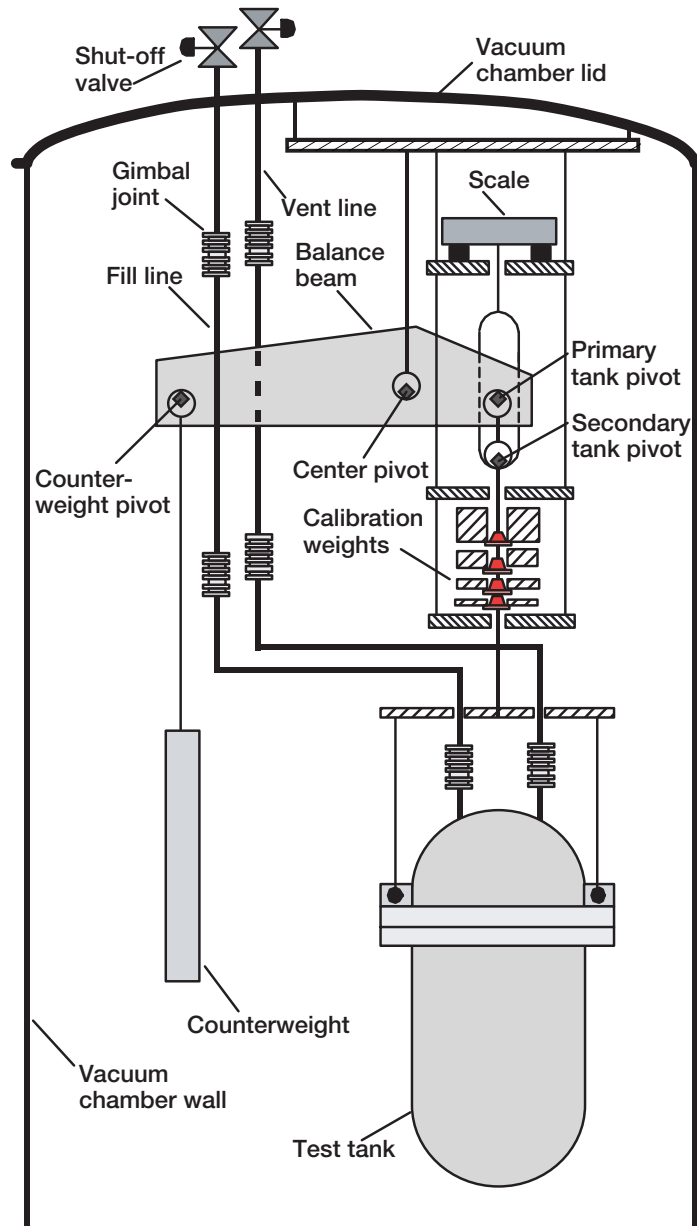

Figure 1.—Schematic of weigh system inside vacuum chamber.

Design Details

The length from the central pivot to the counterweight pivot (61.0 cm (24 in.)) is three times the length from the central pivot to the tank suspension pivot (20.3 cm (8 in.)). Due to the 3:1 lever arm ratio, the assembly is balanced when the mass of the counterweight is one-third the dry tank mass. All pivots are made from 1.6 cm (5/8 in.) hardened steel square stock. The load-bearing edge of each pivot contacts a hardened steel bearing-block with a concave surface. The pivots and bearing-blocks are commercially available and capable of supporting loads far in excess of expected weigh system loads. The contact length of each pivot and bearing-block is 1.3 cm (0.5 in.). The loaded edges of the pivots are placed in a straight line on the balance beam to make the lever arm length ratio independent of beam angular position. The bearing-blocks are all mounted on loose pins to allow alignment with the pivot edges. The

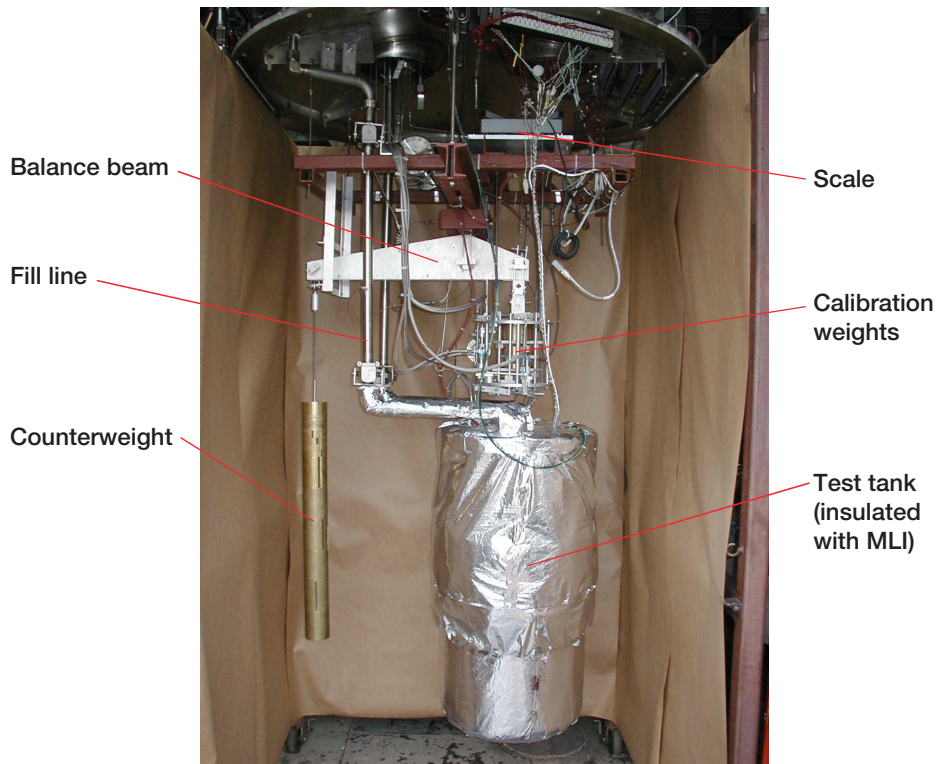

Figure 2.—Photograph of weigh system and insulated test tank outside of vacuum chamber.

central and tank hangers have double bearings, one on each side of the balance beam. The counterweight hanger uses a single pivot edge and bearing-block.

The support structure holds up the balance beam by the center pivot. Thus the center pivot is loaded from the bottom. The counterweight pivot is loaded on the topside. The tank pivot load force is the vector sum of the downward force of the tank plus the lifting force of the scale. If both forces were applied directly to the tank pivot, a measurement error would be introduced when the balance beam is not perfectly level. This error is a result of the differing horizontal distances from the upper and lower edges of the tank pivot to the center pivot. The requirement for a perfectly level balance beam has been eliminated by the use of a secondary tank pivot suspended from the primary tank pivot. The vertical alignment of the secondary pivot is independent of the angular position of the balance beam. The tank and scale forces are applied directly to the secondary tank pivot. Thus the two lever arms are effectively merged into one and cannot change relative lengths as the balance beam tilts.

Strain gauge-type scales are available that provide resolution of one part in 6000. This is beyond the required resolution of one part in 1000, so a scale with a somewhat larger range than the maximum LH₂ weight can be used. The unit selected has a 14 kg (30 lb) range with a certified resolution of 0.002 kg (0.005 lb). Because the unit operates in hard vacuum conditions, heat dissipation from the load transducer is an important consideration. A strain gauge-type sensor was selected because it is a low power device and the metal strain element will transfer heat away from the strain sensor by conduction and radiation to the surrounding hardware. The scale's signal processing features include a variable time constant that is useful for removing noise due to swaying motion or facility vibrations.

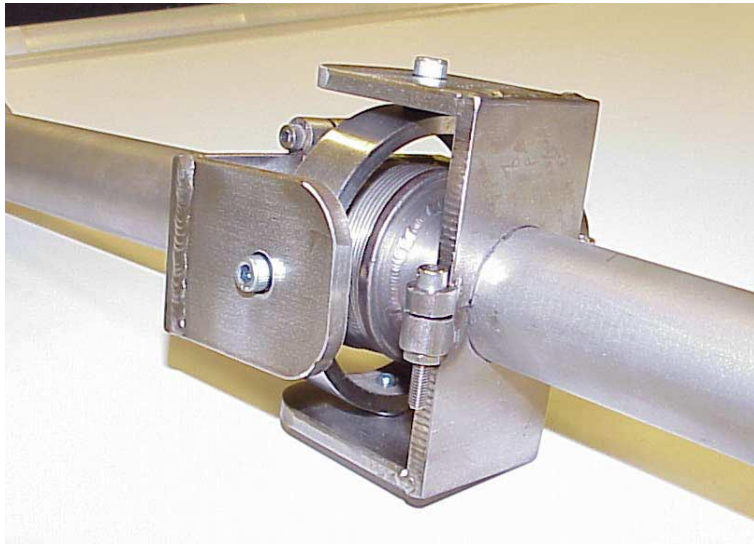

Figure 3.—Photograph of gimbal joint (In final version, yoke-to-tube interface was welded instead of clamped as shown).

The ideal situation for weighing accuracy would be for the tank to hang freely from the balance beam. This is not completely possible, since the fill and vent lines must be physically attached to the tank and the vacuum chamber lid. The transmission of forces through the lines to the tank is greatly reduced by the use of the gimbal joints in each line. A photograph of a gimbal joint is provided in figure 3. Each gimbal joint contains a flexible joint mechanism consisting of two perpendicular yokes attached at four pivot points on a central ring. Ball bearing assemblies are used at each pivot. The bearings are cleaned of grease and oil and operated dry. The central ring envelops, but does not touch, a metal welded-edge flex bellows. The bellows has an inside diameter of 4.6 cm (1.8 in.) and a free length of 1.3 cm (0.5 in.). Each end of the bellows has a flange welded to 3.8 cm (1.5 in.) o.d. stainless tubing. The ends of the yoke mechanisms are also welded to the tubing. The gimbal joint constrains the bellows from expanding in the lengthwise direction while allowing bending motion in both perpendicular axes. The relatively small length-to-diameter ratio of the bellows was selected to avoid squirm at line pressures up to 690 kPa (100 psi) above the external pressure while easily allowing 10° of flex from the centered position. When flexed by hand, the un-pressurized gimbal resistance is barely discernible. As the internal pressure is increased, the bellows stiffens and a slight resistance to bending can be perceived.

Since the deflection of the scale when loaded is negligible, there is little motion of the gimbal joints as the fluid mass in the test tank changes. The primary cause of gimbal joint movement occurs as the fill and vent lines thermally contract and expand during tank filling and venting. When either the fill or vent line becomes cold and contracts, the horizontal segment will be raised at the end connected to the long vertical segment. There will be slight angular rotation of the three line segments relative to each other. All of the gimbal joints in the line will flex to achieve new equilibrium positions. The largest angular deflection occurring during line chilldown is calculated to be slightly more than 0.5° and takes place in the flex joint at the bottom of the long vertical segment. Since the gimbals provide flexibility, there will be little transmission of forces to the tank to distort the suspended weight measurement. The bellows are constructed of thin-wall stainless steel with welded edges. Since the elastic (Young's) modulus of stainless steel is roughly constant over the range from LH₂ to ambient temperature, changes in bellows temperature have a minor effect on gimbal joint behavior. The slight increase in bellows stiffness at cryogenic temperatures (about 7 percent¹²) is negligible compared to the pressure effect described above.

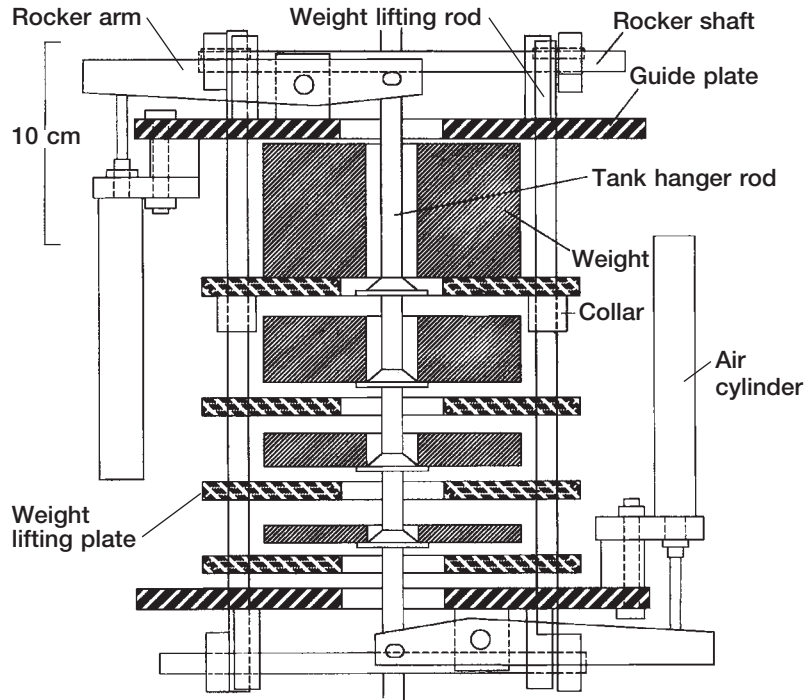

Figure 4.—Schematic drawing of calibration weight sub-assembly.

Other sources of coupling of the test tank to the vacuum chamber lid are the numerous electrical leads for tank instrumentation and power for the LH₂ pump and the test article. The leads are secured at each end but allowed to droop somewhat. Since the leads are not pulled taut and are fairly flexible, this source of coupling is minor relative to that of the fill and vent lines.

Various factors will bias the weight measurement. Such factors include, but are not limited to, friction in the balance beam pivots, friction in the gimbals, stiffness in the bellows that is primarily pressure-dependent, and force transmittal through electrical connections between the vacuum chamber and tank. The calibration weight subsystem is used to verify the proper operation of the weighing system and to perform system level calibration (discussed below). A schematic diagram of the calibration weight assembly is shown in figure 4. The masses of the four weights were measured at NIST on calibrated balances maintained to accuracies of a few milligrams. The masses are: 0.861, 1.75, 3.35 and 6.43 kg (1.90, 3.85, 7.38, and 14.18 lb). Each weight is supported by a lifting plate when it is in the raised position. A rocker shaft coupled to a dedicated pneumatic cylinder moves each of the lifting-plates in one direction. An extension spring returns the plate to the opposite position when pneumatic pressure is removed. When the lifting plate is lowered, the weight is supported solely by a conical weight support on the tank hanger rod.

Calibration Methodology

After the test hardware is completely assembled such that the suspended dry tank weight is firmly established for the test, the scale is zeroed while it remains unattached to the balance beam. Next the scale is connected to the balance beam via the small chain attached to the pivot point at the tank end of the beam. The chain length is adjusted to make the beam approximately level. Small amounts of counterweights are added or removed until the scale reads about 0.2 kg (0.5 lb). This value, called the

scale preload, is set to make certain that the tank exerts a downward pull on the scale when empty. The actual preload value is not critical as long as it is confirmed that the empty tank moment exceeds the counterweight moment. Also, the preload should not exceed the available margin in the scale output range so that the scale is not over-ranged when the tank is completely filled with LH₂. After the bias of the balance beam towards the tank-end is confirmed, the scale can be zeroed again. This final zeroing is generally done after the hardware has been placed in the vacuum chamber.

The four calibration weights are respectively designated as S, M, L and XL for the 0.861, 1.75, 3.35, and 6.43 kg weights. In table 1, the 16 various combinations are specified along with the total mass for each combination.

TABLE 1.—ALL POSSIBLE CALIBRATION WEIGHT COMBINATIONS.

Combination number	Weight size(s)	Total mass, kg	Total mass, lb
1	none	0.000	0.00
2	S	0.862	1.90
3	M	1.75	3.85
4	S+M	2.61	5.75
5	L	3.35	7.38
6	S+L	4.21	9.28
7	M+L	5.09	11.23
8	S+M+L	5.96	13.13
9	XL	6.43	14.18
10	S+XL	7.29	16.08
11	M+XL	8.18	18.03
12	S+M+XL	9.04	19.93
13	L+XL	9.78	21.56
14	S+L+XL	10.6	23.46
15	M+L+XL	11.5	25.41
16	S+M+L+XL	12.4	27.31

Initially it was not known whether the system response would be linear or how much data would be needed to obtain a good calibration result. With testing and experience, it was determined that using eight of the above combinations provided a sufficient number of calibration points. The ultimately selected procedure used the following sequence of combination numbers: 1, 5, 9, 11, 15, 13, 7, 3, 1. The sequence starts at no load, increases to maximum load, and then returns to no load. This allows inspection of the system response for hysteresis due to loading versus unloading.

The calibration procedure repeated the weight sequence at a number of tank pressures to determine the system response to tank pressure. Four sequences for pressure were used (values shown are the difference between internal and external tank pressures):

- | | |
|----------------------------------|----------------------------|
| (1) 0, 280 kPa | (0, 40 psi) |
| (2) 0, 140, 280 kPa | (0, 20, 40 psi) |
| (3) 0, 140, 280, 210, 70, 0 kPa | (0, 20, 40, 30, 10, 0 psi) |
| (4) 0, 210, 380, 310, 105, 0 kPa | (0, 30, 55, 45, 15, 0 psi) |

The first and second sequences were used in initial system check-out calibrations. Pressure sequence number 3 introduced a check for pressure hysteresis and number 4 extended the upper limit to the

maximum allowed facility pressure once favorable results were obtained at lower and intermediate pressure levels.

The calibration can be performed in either a vacuum or non-vacuum environment. If the calibration is done in vacuum conditions, the external gas density is zero and there is no tank buoyancy force. Calibration in a non-vacuum condition introduces a tank buoyancy effect that is incorporated into the calibration result. In both cases, it is necessary to determine the gas density inside the tank in order to calculate the additional mass of gas in the tank. During testing, initial calibrations were done outside the vacuum chamber (in air at atmospheric pressure) with GN₂ used to pressurize the tank. Later calibrations used GHe to pressurize the tank. When the tank was placed inside the vacuum chamber, the chamber was either filled with GHe at 1 atm or evacuated during calibration of the weighing system. The calibration process was done at ambient temperature over a tank pressure range from 0 to a maximum of 380 kPa (55 psia).

A regression analysis is used to fit a calibration equation of the form:

$$m_i = \alpha + \beta m_a + \gamma \Delta P \quad (1)$$

where α , β , and γ are fitted calibration constants, ΔP is the difference between the test tank pressure and pressure outside the tank, m_i is the indicated mass output from the scale and m_a is the applied mass. The intercept, α , is the sum of the zero-load reading of the scale, the scale pre-load value, and the tank buoyancy component. The second term is the dominant term due to the applied mass, while the last term is a correction for the loading effect that occurs when the gimbal joints are internally pressurized. The applied mass is defined as:

$$m_a = m_{cal} + \rho_i V_w \quad (2)$$

m_{cal} is the mass of the applied calibration weight(s) from table 1. In theory, the calibration weight amounts should also be corrected for buoyancy if not in a vacuum, but this correction is negligible for the desired accuracy requirement. The last term in equation (2) is the additional weight of pressurant gas in the tank during calibration. V_w is the weighed volume—it is approximately, but not exactly, equal to the tank volume, V_t . V_t is the total available fluid volume of the tank, equal to the total tank volume minus all volume displaced by internal hardware, such as the pump, spray bar, instrumentation and electrical leads. V_t also includes the internal volume of the fill and vent lines.

V_t was measured by capping the flanges of the fill and vent lines just outside the vacuum chamber lid. The test tank was purged with GN₂ and then slowly pressurized with GN₂ to raise the pressure from 117 to 345 kPa (17 to 50 psia). The total injected mass, Δm_{GN_2} , was obtained by integrating the flowrate as measured by a mass flowmeter. The tank volume is calculated as follows:

$$V_t = \frac{\Delta m_{GN_2}}{\rho_{GN_2,f} - \rho_{GN_2,i}} \quad (3)$$

The initial and final GN₂ densities are based on tank pressure and temperature measurements at the start and end of the pressurization process. This measurement was repeated three times with a resulting standard deviation of 0.7 percent. A correction to the result from equation (3) is necessary since the scale does not sense the weight of fluid in the upper portion of the fill and vent lines. The weighed volume is the tank volume sensed by the scale when the tank contains gas and liquid. This volume region includes

the short vertical section attached to the tank lid and one-half of horizontal section of both the fill and vent lines. The volume correction is computed from the lengths and diameters of the unweighed volume regions in the lines and is subtracted from the measured volume:

$$V_w = V_t - V_c \quad (4)$$

The volume correction is 2.6 percent of the uncorrected volume and has an uncertainty of 5 percent. The resulting weighed tank volume is 0.156 m³ (5.49 ft³) at ambient temperature and has an uncertainty of 1.4 percent. This uncertainty has no significant impact on the accuracy of fluid mass measurements obtained by weighing, but does impact the conversion to volume equivalents, as will be discussed in a later section.

By rearranging equation (1) and recognizing that the applied load is identical to the fluid weight, the useful form of the calibration equation is obtained:

$$m_f = \frac{1}{\beta} [m_i - \alpha - \gamma \Delta P] \quad (5)$$

Calibration Results

Eight calibrations of the weigh system were conducted. Table 2 gives the internal gas, external gas and pressure, calibration weight sequence and tank pressure sequence for each valid calibration. For calibration numbers 4 to 7, each pressure sequence started and ended at 0 kPa (0 psi). Only data from the final 0 kPa state were used in the regression analysis to prevent overweighing the regression with 0 kPa data. The number of data points, fitted regression constants, root-mean-squared error of the regression and the estimated accuracy based on a two-sigma (95 percent) confidence level are listed in table 3. Two of the cases, numbers 4 and 5, each contained one data point assumed to be an outlier and removed using Chauvenet's criterion.¹³

TABLE 2.—CALIBRATION CONDITIONS.

Calibration number	Internal gas	External gas	External pressure	Calibration weight sequence (Numbers from table 1)	Pressure sequence
1	N ₂	air	1 atm	see note 1	see note 4
2	N ₂	air	1 atm	see note 1	see note 4
3	He	air	1 atm	see note 2	see note 5
4	He	He	1 atm	see note 2	see note 6
5	He	N/A	0 atm	see note 2	see note 6
6	He	N/A	0 atm	see note 2	see note 6
7	He	N/A	0 atm	see note 3	see note 6
Note 1:	2,4,8,16,8,4,2,1,9,13,15,16,15,13,9,1,14,5,8,16,2,11,1,8,2,14,11,16,5,1				
Note 2:	1,5,9,11,15,13,7,3,1				
Note 3:	1,5,7,3,1				
Note 4:	0,276 kPa (0,40 psi)				
Note 5:	0,138,276 kPa (0,20,40 psi)				
Note 6:	138,276,207,69,0 kPa (20,40,30,10,0 psi)				

TABLE 3.—CALIBRATION RESULTS.

Calibration number	Number points	Intercept, α , kg (lb)	Mass coefficient, β	ΔP coefficient, γ , kg/kPa (lb/psi)	RMS error, kg (lb)	Percent error full scale, 2σ confidence
1	60	0.0758 (0.167)	0.989	-0.00120 (-0.0182)	0.020/0.045	0.36
2	60	0.0889 (0.196)	0.982	-0.000987 (-0.0150)	0.020/0.045	0.36
3	24	0.222 (0.489)	0.991	-0.000783 (-0.0119)	0.021/0.046	0.37
4	39	0.0835 (0.184)	0.988	-0.00113 (-0.0172)	0.025/0.055	0.44
5	39	0.0134 (0.0296)	0.991	-0.00108 (-0.0164)	0.010/0.023	0.18
6	40	0.205 (0.452)	0.991	-0.00107 (-0.0162)	0.044/0.096	0.77
7	20	0.0635 (0.140)	0.991	-0.000763 (-0.0116)	0.039/0.086	0.69
Average:			0.989	-0.00100 (-0.0152)	0.026/0.057	0.45

The α value is an approximate value of the preload, the weight indicated by the scale under the condition of zero load and no internal-to-external pressure difference. Since the preload varied from test to test, the results differ as shown in table 3. Low values for α indicate the scale was zeroed after final adjustments to the counterweight mass. The mass coefficient, β , was very consistent, with an average value of 0.989 ($\sigma = 0.34$ percent). If the system were perfectly friction-free and completely free-hanging, β would equal 1.0. The ΔP coefficient, γ , had an average value of -0.00100 kg/kPa (-0.0152 lb/psi) ($\sigma = 17$ percent). The small absolute value of this fitted constant reflects the much smaller (but not negligible) influence of the pressure effect, while the negative sign indicates that increasing the tank pressure causes a reduction in the scale reading. This was indeed the case when the pressure effect is isolated from the additional applied weight of the pressurant gas. The pressure effect is attributed to the existence of a small tank lifting force produced in the fill or vent line as one or more flexed bellows attempt to straighten when internally pressurized. At 345 kPa (50 psi), a 3.4 N (0.76 lb) lifting force is generated.

Some anomalous results were obtained during calibration number 7. Post-test analysis determined that β and γ from the regression fitting differed significantly from previous results if all points were included in the data set. However, if the calibration weight combinations that included the XL weight were removed (combination numbers 9, 11, 13, and 15), then the regression results were similar to previous results. Subsequently, calibration no. 8 was performed and even less consistent calibration results were obtained. Calibration number 8 is considered invalid and is not included in the table. Calibration numbers 7 and 8 were done after a repair to unrelated test hardware that required removal of the test package from the vacuum chamber. A likely scenario is that during these repairs, the calibration weight sub-assembly was adversely affected. Due to facility scheduling constraints, the weighing system had to be disassembled immediately following calibration number 8 and the cause of anomalous behavior could not be thoroughly investigated.

It was observed that the scale output would drift over long periods under constant load conditions. For example, the zero point would be set in the morning prior to testing and then rechecked at the end of the day after all LH₂ had been boiled off. Typically the zero reading at the end of the day would be on the order of 0.05 kg (0.1 lb). However, by the following morning, the scale output would return to zero or thereabouts. A long-term drift test was conducted over a weekend with the scale output and scale temperature recorded at 15 min intervals. The data are shown in figure 5 where the scale output and temperature are normalized by subtracting the initial values (2.51 kg, 289 K (5.53 lb, 520 °R)). The temperature is an average of four readings obtained from thermocouples attached to steel mounting plates above and below the strain gauge transducer. The steel plates have significant thermal mass, as does the transducer, so there could be some time lag between the temperatures of these components. There appears

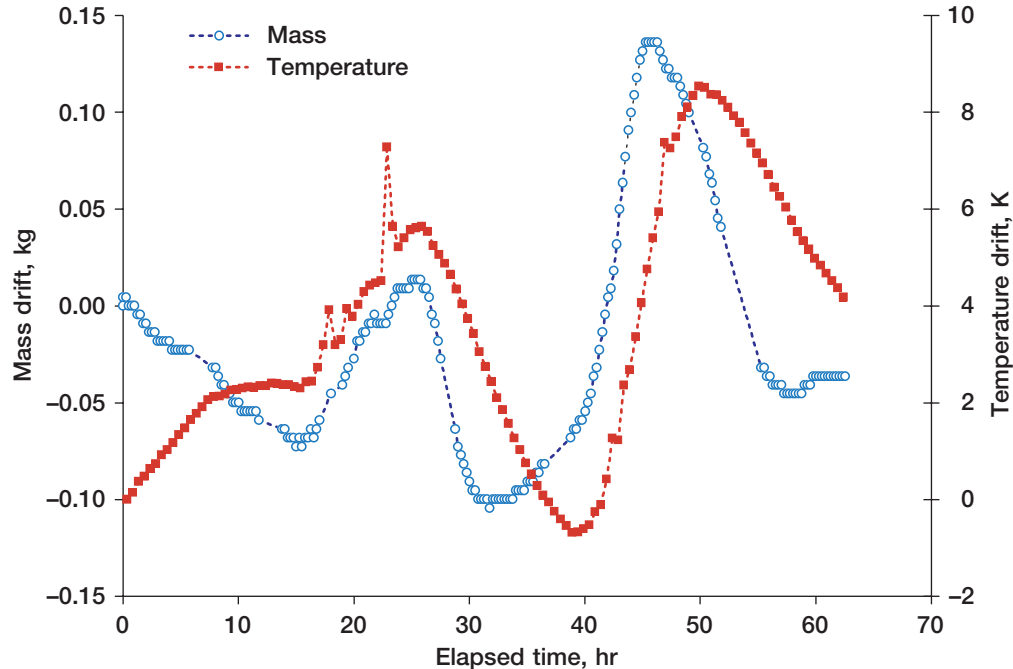

Figure 5.—Long-term drift of scale output and scale temperature excursion.

to be a correlation between scale output and scale temperature after 16 hr. The data were recorded on autumn days with cool overnight and warm daytime temperatures. The peak-to-peak temperature change is about 9 K (16 °R). The associated peak-to-peak scale drift is about 0.2 kg (0.5 lb). The approximate temperature sensitivity is therefore 0.02 kg/K (0.03 lb/°R). The initial 16 hr of the long-term drift data show a separate transient effect thought to be a related to cold fill and vent lines present at the start of the test. Prior to the test, LH₂ was present in the tank. The vent line was cold due to boil-off flow and the fill line was chilled when the LH₂ was expelled through the dip tube and fill line. The upper portions of both lines are not insulated. Significant radiative heat transfer could have cooled the thermocouples mounted on the surface of the mounting plates while the transducer remained warm because the plates shield it.

Conversion of Mass Measurement to Volume

Several of the low-gravity gauging concepts do not measure mass directly. The compression and gas injection methods, for example, measure ullage volume. Volume measurements cannot be readily compared to the fluid mass (weight) unless one measurement is converted into the units of the other. The liquid fill level, or percent of liquid in the tank by volume, is obtained from knowledge of the total fluid mass and density of the liquid and vapor phases. The conversion is simple if the tank contains a single fluid species and the fluid is isothermal (both phases are at the saturation temperature). In this case the liquid fill level is calculated as:

$$\lambda = \frac{1}{V_t} \left[\frac{m_f - \rho_v V_t}{\rho_\ell - \rho_v} \right] \times 100 \quad (6)$$

Similarly, for the isothermal case with the added presence of non-condensable helium gas in the tank ullage, the relationship between fluid weight and fill level is:

$$\lambda = \frac{1}{V_t} \left[\frac{m_f - (\rho_v + \rho_{GHe})V_t}{\rho_\ell - \rho_v - \rho_{GHe}} \right] \times 100 \quad (7)$$

In this case with a two-component ullage, Dalton's Law¹⁴ applies and the partial pressure of the vapor is the saturation pressure of the liquid at the isothermal tank temperature. The helium partial pressure is the difference between the total tank pressure and the vapor partial pressure.

Cryogenic tanks in a gravitational environment are unlikely to be isothermal unless the tank is well-mixed or otherwise conditioned. Use of equations (6) or (7) under thermally stratified conditions may lead to substantial conversion errors. When thermal stratification exists within the tank volume space, accurate conversion from mass to volume fill requires detailed mapping of the temperature gradient(s) within the tank plus the species concentration gradient if applicable. Furthermore, a corresponding mapping of the local tank volume distribution with the temperature and concentration gradients is necessary. Even if the idealized isothermal conditions are assumed to exist, there will be a reduction in the measurement accuracy due to the uncertainty of the measured parameters such as tank pressure, tank volume and fluid mass. An example calculation is provided in appendix B where a measurement uncertainty of 0.1 percent of full-scale mass translates to an uncertainty in liquid fill level of 0.5 percent. Again, it is important to recognize that the conversion is based on ideal conditions and that the true conversion uncertainty may be greater than equations (6) or (7) suggest.

Future Improvements

A necessary modification is the need to isolate the load transducer from the cyclic temperature change in the vacuum chamber or to calibrate the transducer over the expected temperature range. Inclusion of temperature compensation in the calibration will most likely be necessary, but it would be good practice to also minimize the peak-to-peak temperature variations by use of radiation shielding and low-conductivity support hardware.

Although the gimbal joints performed well, it was noted that some had an off-center neutral position and did not flex with equal ease in all azimuthal directions. When separated, neither the bellows nor the yoke mechanisms exhibited this behavior. It is suggested that the yokes were slightly misaligned with respect to the bellows centerline and that tighter manufacturing tolerances would be beneficial.

For simplicity, the fill and vent line diameters were of equal diameter. In practice, the vent line is sized to accommodate the boil-off flow rate that can pass through the vent valve. The fill line is used to flow liquid and could be significantly smaller, given the small tank volume. The current line diameter is 3.8 cm (1.5 in.) but could be reduced to less than 2.5 cm (1.0 in.). This would reduce the attached volume of the fill line and its effect on the uncertainty of the total tank volume.

A design improvement to allow in-place adjustment of the fill and vent line attachment positions would be helpful to fine-tune the orientation of these lines. Currently each line has a flange fitting at each end and is simply bolted in place. The gimbal joints take up any misalignment. If the attachment points at the chamber lid had vertical and lateral adjustment capability, the set-up would allow for careful positioning to place all gimbal joints near their neutral points. This could reduce the effect of tank pressure on the weigh system performance.

A source of concern with the present design of the calibration weight sub-assembly is the potential leakage of the pneumatic cylinders used to move the calibration weights. The original design concept was

to use vacuum pumping on the cylinders to prevent leakage into the vacuum chamber. This was not feasible and the double-ended cylinders were capped off on the unused end. They did not leak during testing, but a design change would be desirable prior to further use.

Conclusions

A reference weighing system based on a counterbalanced dry tank has been demonstrated to have a short-term measurement accuracy of approximately 0.5 percent of the full tank liquid mass. Long-term measurement accuracy was found to be degraded by temperature transients in the operating environment but can be eliminated by improving the thermal isolation of the strain gauge transducer or including temperature compensation in the calibration process. Further improvements have been identified that will improve measurement accuracy to within 0.1 percent of full-scale liquid mass.

References

1. Dodge, F.T., Green, S.T., Petullo, S.P., and Van Dresar, N.T., "Development and Design of Zero-g Liquid Quantity Gauge for Solar Thermal Vehicle," NASA/TP—2002-211595, November 2002.
2. Rogers, A.C., Dodge, F., and Behring, K.A., "Feasibility Demonstration of Cryogenic Fluid Gauging for Space Vehicle Applications," *Journal of Propulsion and Power*, Vol. 11, No. 5, September–October 1995.
3. Monti, R. and Berry, W., "Liquid Gauging in Space: The G-22 Experiment," *ESA Journal*, Vol. 18, 1994.
4. Justak, J.F., Ehlers, T.J., and Caimi, F.M., "An Optical Fuel/Oxidizer Sensor for Zero-G Environments," Final Report, NASA SBIR Phase I, Contract No. NAS8–97135, August 1997.
5. Justak, J.F., Ehlers, T.J., Caimi, F.M., and Kocak, D.M., "An Optical Fuel/Oxidizer Sensor for Zero-G Environments," Final Report, NASA SBIR Phase II, Contract No. NAS8–98068, February 2000.
6. Chobotov, M.V. and Purohit, G.P., "Low-Gravity Propellant Gauging System for Accurate Predictions of Spacecraft End-Of-Life," *Journal of Spacecraft and Rockets*, Vol. 30, No. 1, January–February 1993.
7. Lovell, T., "Tank Gauging in Low Gravity by Dynamical (e.g., Acoustic or RF) Signal Analysis," Final Report, NASA SBIR Phase I, Contract No. NAS3–99023, June 1999.
8. Bendix Corp., "Design, Development and Manufacture of a Breadboard Radio Frequency Mass Gauging System," Volume 1: Phase B Final Report, NASA/CR–120620.
9. Ball Aerospace Systems Division, "Zero-Gravity Quantity Gauging System," Final Report, NASA/CR–185602, December 1989.
10. ANSI/NCSL Z540–1–1994, American National Standard for Calibration, Calibration Laboratories and Measuring and Test Equipment—General Requirements, National Conference of Standards Laboratories, August 1994.
11. Handbook for the Interpretation and Application of ANSI/NCSL Z540–1–1994, National Conference of Standards Laboratories, Laboratory Evaluation Committee, October 1995.
12. Reed, R.P. and Clark, A.F., Materials at Low Temperatures, American Society for Metals, Metals Park, Ohio, 1983, ISBN: 0–87170–146–4
13. Holman, J.P., Experimental Methods for Engineers, Third Edition, McGraw-Hill, New York, NY, 1978.
14. Van Wylen, G.J. and Sonntag, R.E., Fundamentals of Classical Thermodynamics, Second Edition, Wiley and Sons, New York, NY, 1976.
15. Coleman, H.W. and Steele, W.G. Experimentation and Uncertainty Analysis for Engineers, Second Edition, Wiley and Sons, New York, NY, 1999.
16. GASPAK, Version 3.20, Cryodata, Inc., Louisville, CO, 1992.

Appendix A

Test Tank Specifications and Tank Insulation Performance

The LH₂ test tank is cylindrical with standard ASME flanged and dished ends. It has a diameter of 0.51 m (20 in.) and an overall length of 0.97 m (38 in.). The tank volume with all internal hardware removed and not including the connected volume of the fill and vent lines is 0.16 m³ (5.8 ft³). The empty tank mass is approximately 136 kg (300 lb). The tank consists of upper and lower sections bolted together at a circular flange as shown in the photographs in figures A1 and A2. All penetrations are placed in the lid. A central port of 5.7 cm (2.25 in.) diameter is used for electrical feed-throughs. Four ports of 3.8 cm (1.5 in.) diameter surround the central port as shown in figure A2. The fill and vent lines are attached to two of the smaller ports on opposite sides of the central port. The remaining ports can be used for additional electrical feed-throughs, gas sampling probes or other purposes. The lid is suspended from four attachment points drilled to accept 0.64 cm (0.25 in.) clevis pins. Two perpendicular and intersecting cross members are located inside the tank lid for the primary purpose of supporting internal hardware such as the LH₂ pump, the spray bar assembly, instrumentation rakes and the gauging test article. The cross members are visible in the figure A3 photograph.

Fifty layers of multi-layer insulation (MLI) were used to insulate the tank. The layers consisted of double aluminized Mylar separated with Dacron netting. The MLI was fitted to the tank and overlapped on the tank sides. The steady-state boil-off rate of LH₂ was measured at 0.34 standard m³/hr (12 standard ft³/hr), which corresponds to a total heating rate of 3.5 W (12 BTU/hr). Most of this heat leak enters the tank from the top, since all penetrations are attached to the lid. The self-pressurization rate of the tank under locked-up conditions was 23±1 kPa/hr (3.3±0.2 psi/hr) at 32 and 62 percent fill and 72±4 kPa/hr (10.5±0.6 psi/min) at 92 percent fill. At the high fill level, the cross members in the lid are submerged.



Figure A-1.—Tank bottom and barrel section.
(Shown in inverted position.)



Figure A-2.—Tank lid section. (The five ports are capped off.)

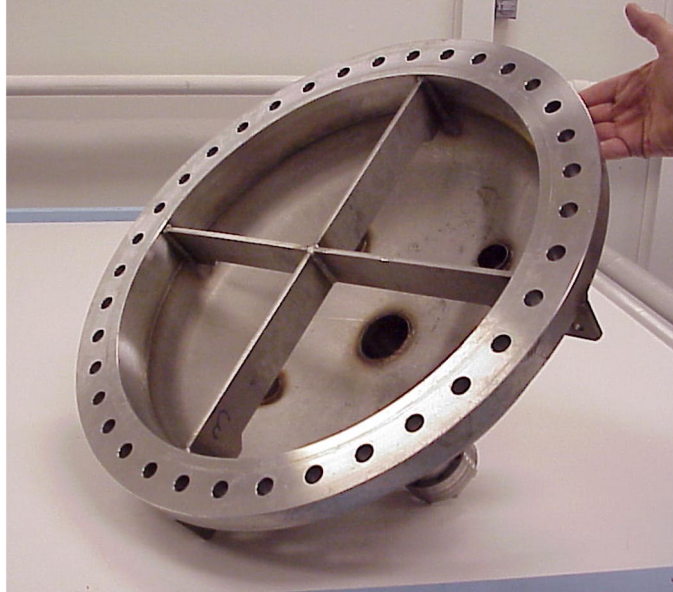

Figure A-3.—Photograph of underside of tank lid showing cross members.

This is thought to lead to more direct heat conduction to the liquid which causes an increased boil-off rate. Chamber vacuum levels were typically 7×10^{-3} Pa (5×10^{-5} torr) or less.

A LH₂ pump and spraybar were installed in the tank. The pump has a 379 liter/min (100 gpm) design point. A horizontal cross-shaped spraybar is connected to the pump and mounted on top of the cross members in the tank lid. The spraybar has a staggered grid of 3.2 mm (0.125 in.) diameter holes drilled through the tube wall at angular positions of 0°, ±40°, and ±70° from the vertical. There are approximately 115 holes, with holes omitted at locations where the discharge would directly impinge on either of the instrumentation rakes supported by the cross members. Operation of the pump effectively cools the tank lid to the liquid temperature in less than a minute. Since the pump dissipates approximately 300 W (1020 BTU/hr), extended operation of the pump is an effective means of rapidly heating the tank contents.

Appendix B

Uncertainty Analysis of an Example Conversion of Fluid Mass Measurement to Liquid Fill Level

Consider a case using the experimental hardware described in this report. The test tank ($V_t = 0.16 \text{ m}^3$ (5.6 ft³)) contains pure hydrogen assumed to be isothermal at a measured tank pressure of 103 kPa (15 psia) and fluid mass of 9.1 kg (20 lb). The saturated liquid and vapor densities ($\rho_\ell = 70.7 \text{ kg/m}^3$ (4.41 lb/ft³) and $\rho_v = 1.36 \text{ kg/m}^3$ (0.0852 lb/ft³)] are determined from the pressure measurement only. The resulting liquid fill level computed from equation (6) is 80.5 percent.

Using classical uncertainty analysis,¹⁵ the following measurement and property uncertainties are estimated:

$$U_P = 3.4 \text{ kPa (0.5 psi)} \quad (\text{B1})$$

$$U_{\rho_\ell} = 0.13 \text{ kg / m}^3 \text{ (0.0082 lb / ft}^3\text{)} \quad (\text{B2})$$

$$U_{\rho_v} = 0.041 \text{ kg / m}^3 \text{ (0.0026 lb / ft}^3\text{)} \quad (\text{B3})$$

$$U_{V_t} = 7.9 \times 10^{-4} \text{ m}^3 \text{ (0.028 ft}^3\text{)} \quad (\text{B4})$$

$$U_{m_f} = 0.011 \text{ kg (0.025 lb)} \quad (\text{B5})$$

The uncertainty of pressure measurement is based on a 345 kPa (50 psia) full-scale transducer with an accuracy of 1 percent of full scale. The density uncertainties are calculated using real property data¹⁶ sensitivities and the pressure measurement uncertainty. The tank volume uncertainty is assumed to be 0.5 percent of the total volume. Reducing this level of tank volume uncertainty is certainly a challenge, considering the issues of attached volumes of the fill and vent lines, thermal contraction under cryogenic conditions and that the tank contains internal hardware that displaces fluid volume. The weight uncertainty is assigned a value equal to the design goal of the weighing system—0.1 percent of the LH₂ weight in the fully loaded tank. Equation B6 is used to calculate the uncertainty in liquid fill level, where the partial derivatives are obtained by differentiating equation (6).

$$U_\lambda = \left[\left(\frac{\partial \lambda}{\partial \rho_\ell} U_{\rho_\ell} \right)^2 + \left(\frac{\partial \lambda}{\partial \rho_v} U_{\rho_v} \right)^2 + \left(\frac{\partial \lambda}{\partial V_t} U_{V_t} \right)^2 + \left(\frac{\partial \lambda}{\partial m_f} U_{m_f} \right)^2 \right]^{1/2} \quad (\text{B6})$$

Values for the partial derivatives were determined as follows:

$$\frac{\partial \lambda}{\partial \rho_\ell} = \frac{-\lambda}{\rho_\ell - \rho_v} = -1.16 \frac{\%}{\text{kg/m}^3} = -18.6 \frac{\%}{\text{lbm/ft}^3} \quad (\text{B7})$$

$$\frac{\partial \lambda}{\partial \rho_v} = \frac{\lambda - 100}{\rho_\ell - \rho_v} = -0.281 \frac{\%}{\text{kg/m}^3} = -4.50 \frac{\%}{\text{lbm/ft}^3} \quad (\text{B8})$$

$$\frac{\partial \lambda}{\partial V_t} = \frac{-100 m_f}{(\rho_\ell - \rho_v) V_t^2} = -520 \frac{\%}{m^3} = -14.7 \frac{\%}{ft^3} \quad (B9)$$

$$\frac{\partial \lambda}{\partial m_f} = \frac{100}{(\rho_\ell - \rho_v) V_t} = 9.09 \frac{\%}{kg} = 4.12 \frac{\%}{lbm} \quad (B10)$$

For this example, the resulting uncertainty in fill level, U_λ , is ± 0.5 percent of total tank volume. The largest source of uncertainty is the measurement of tank volume, followed by the liquid density uncertainty due to the measurement of tank pressure. Other examples will have different results. The point of this example is to show that a reduction in accuracy (or increase in uncertainty) results whenever the tank weight measurement is converted to a corresponding volume measurement such as liquid fill level.

REPORT DOCUMENTATION PAGE			<i>Form Approved</i> <i>OMB No. 0704-0188</i>	
Public reporting burden for this collection of information is estimated to average 1 hour per response, including the time for reviewing instructions, searching existing data sources, gathering and maintaining the data needed, and completing and reviewing the collection of information. Send comments regarding this burden estimate or any other aspect of this collection of information, including suggestions for reducing this burden, to Washington Headquarters Services, Directorate for Information Operations and Reports, 1215 Jefferson Davis Highway, Suite 1204, Arlington, VA 22202-4302, and to the Office of Management and Budget, Paperwork Reduction Project (0704-0188), Washington, DC 20503.				
1. AGENCY USE ONLY (<i>Leave blank</i>)	2. REPORT DATE July 2003	3. REPORT TYPE AND DATES COVERED Technical Memorandum		
4. TITLE AND SUBTITLE Reference Gauging System for a Small-Scale Liquid Hydrogen Tank			5. FUNDING NUMBERS WBS-22-721-26-11	
6. AUTHOR(S) Neil T. Van Dresar and James D. Siegwarth				
7. PERFORMING ORGANIZATION NAME(S) AND ADDRESS(ES) National Aeronautics and Space Administration John H. Glenn Research Center at Lewis Field Cleveland, Ohio 44135-3191			8. PERFORMING ORGANIZATION REPORT NUMBER E-13975	
9. SPONSORING/MONITORING AGENCY NAME(S) AND ADDRESS(ES) National Aeronautics and Space Administration Washington, DC 20546-0001			10. SPONSORING/MONITORING AGENCY REPORT NUMBER NASA TM-2003-212455	
11. SUPPLEMENTARY NOTES Neil T. Van Dresar, NASA Glenn Research Center; and James D. Siegwarth, National Institute of Standards and Technology, Boulder, Colorado 80305. Responsible person, Neil T. Van Dresar, organization code 5870, 216-977-7533.				
12a. DISTRIBUTION/AVAILABILITY STATEMENT Unclassified - Unlimited Subject Category: 14 Available electronically at http://gltrs.grc.nasa.gov This publication is available from the NASA Center for AeroSpace Information, 301-621-0390.			12b. DISTRIBUTION CODE	
13. ABSTRACT (<i>Maximum 200 words</i>) A system to accurately weigh the fluid contents of a small-scale liquid hydrogen test tank has been experimentally verified. It is intended for use as a reference or benchmark system when testing low-gravity liquid quantity gauging concepts in the terrestrial environment. The reference gauging system has shown a repeatable measurement accuracy of better than 0.5 percent of the full tank liquid weight. With further refinement, the system accuracy can be improved to 0.10 percent of full scale. This report describes the weighing system design, calibration, and operational results. Suggestions are given for further refinement of the system. An example is given to illustrate additional sources of uncertainty when mass measurements are converted to volume equivalents. Specifications of the companion test tank and its multi-layer insulation system are provided.				
14. SUBJECT TERMS Liquid hydrogen; Liquid levels; Weight measurement; Standards			15. NUMBER OF PAGES 24	
			16. PRICE CODE	
17. SECURITY CLASSIFICATION OF REPORT Unclassified	18. SECURITY CLASSIFICATION OF THIS PAGE Unclassified	19. SECURITY CLASSIFICATION OF ABSTRACT Unclassified	20. LIMITATION OF ABSTRACT	