

## II.D.1 Zeolite Membrane Reactor for Water-Gas Shift Reaction for Hydrogen Production

Jerry Y.S. Lin

Department of Chemical Engineering

PO Box 876006

Arizona State University

Tempe, AZ 85287

Phone: (480)965-7769; Fax: (480)965-0037

E-mail address: Jerry.Lin@asu.edu

DOE Technology Development Manager:

Arlene Anderson

Phone: (202) 586-3818; Fax: (202) 586-9811

E-mail: Arlene.Anderson@ee.doe.gov

DOE Project Officer: Jill Gruber

Phone: (303) 275-4961; Fax: (303) 275-4753

E-mail: Jill.Gruber@go.doe.gov

Contract Number: DE-PS36-03GO93007

Subcontractors:

- University of Cincinnati, Cincinnati, OH
- Arizona State University, Tempe, AZ
- Ohio State University, Columbus, OH

Start Date: July 1, 2005

Projected End Date: June 30, 2009

### Objectives

- Synthesize chemically and thermally stable silicalite membranes with hydrogen permeance  $>5 \times 10^{-7}$  mol/m<sup>2</sup>·s Pa and H<sub>2</sub>/CO<sub>2</sub> selectivity  $>50$ .
- Fabricate tubular silicalite membranes and membrane reactor module suitable for membrane reactor applications.
- Identify experimental conditions for the water-gas shift (WGS) reaction in the zeolite membrane reactor that will produce a hydrogen stream with at least 94% purity and a CO<sub>2</sub> stream with 97% purity.

### Technical Barriers

This project addresses the following technical barriers from the Production section of the Hydrogen Production of the Hydrogen, Fuel Cells and Infrastructure Technologies Program Multi-Year Research, Development and Demonstration Plan:

- (A) Reforming Capital Costs
- (C) Operation and Maintenance
- (K) Durability

(N) Hydrogen Selectivity

(P) Flux

### Technical Targets

This project is conducting fundamental studies of zeolite membrane reactors to perform WGS for hydrogen production. Insights gained from these studies will be applied toward the development of low-cost, high-efficiency technology for distributed and central hydrogen production that meet the following DOE 2010 hydrogen storage targets:

- Cost: \$0.4/kg
- Flux rate: 200 scfh/ft<sup>2</sup>
- Hydrogen recovery:  $>80\%$
- Hydrogen quality: 99.5%
- Operating capability: 400 psi
- Durability: 26,280 hrs

### Accomplishments

Developed and studied methods and techniques for:

- Synthesis of disk-shaped supports with intermediate zirconia and silicalite layers (improvement of thermal stability).
- Improved understanding of gas transport, permeation and separation in microporous zeolite membranes at high temperatures.
- Development of silicalite membranes modified by thermal cracking method (H<sub>2</sub> permeance:  $>1 \times 10^{-7}$  mol/m<sup>2</sup>·s Pa, H<sub>2</sub>/CO<sub>2</sub> permselectivity: 20, H<sub>2</sub>/CO<sub>2</sub> separation selectivity: 13).
- Development of the cost-effective microwave method to synthesize the silicalite membranes (shorter time and less energy consumption).
- Fabrication of tubular silicalite membranes and membrane reactor module suitable for membrane reactor applications.
- Development of membrane support by colloidal casting.
- Development of catalysts for the WGS membrane reactor application.



### Introduction

Gasification of biomass or heavy feedstock to produce hydrogen fuel gas using current technology

includes partial oxidation to produce syngas, the WGS reaction to convert carbon monoxide with water to hydrogen, separation of hydrogen from the product stream, and removal of water vapor and other impurities (such as  $\text{H}_2\text{S}$ ) from the  $\text{CO}_2$  containing stream. Commercially, WGS is normally conducted in two or more reactor stages with inter-cooling to maximize conversion for a given catalyst volume. Complete conversion of WGS is possible in a single membrane reactor at high temperatures ( $\sim 400^\circ\text{C}$ ). The membrane removes product hydrogen from the reactor, facilitating higher conversion at a given temperature.

This project is focused on experimental and theoretical studies of the synthesis of a new hydrogen permselective and thermally/chemically stable zeolite membrane and its use in the membrane reactor for the WGS reaction to produce hydrogen and  $\text{CO}_2$  rich streams. The membrane reactor system is designed for operation with feeds containing sulfur or other biomass residual contaminants. The zeolite membrane consists of a continuous thin ( $1\text{--}3\ \mu\text{m}$ ), aluminum-free silicalite film without intercrystalline micropores on a support with macroporous zirconia and mesoporous silicalite intermediate layers. These composite silicalite membranes in disk and tubular geometries were prepared by a unique technique that combines several synthesis methods including a template-free secondary growth step. Research efforts were also directed towards development of the cost-effective microwave method to synthesize the MFI (a zeolite structure code) zeolite (silicalite and high Si/Al ratio ZSM-5) membranes in disk and tubular geometries. A new catalyst was developed for the WGS reaction under membrane reactor conditions. The final research task is to perform experimental and modeling studies on the performance of the WGS reaction in the membrane reactors with the silicalite membranes and the catalyst developed in this project. The results obtained in this project will enable development of a large-scale one step membrane reactor process for the WGS reaction for cost-effective production of hydrogen to below  $\$0.40/\text{kg}$ .

## Approach

The approach used in this project is to study fundamental issues related to synthesis of high quality, stable zeolite membranes and a membrane reactor for WGS reaction and hydrogen separation. The details of project are to (1) synthesize disk-shaped and tubular supports with desired intermediate layers and silicalite membranes with a template-free hydrothermal synthesis method, (2) optimize the hydrothermal synthesis condition and perform thorough permeation and separation characterization of silicalite and ZSM-5 membranes, (3) perform chemical vapor deposition (CVD) for improvement of  $\text{H}_2$  permselectivity, (4) develop a microwave synthesis approach to more

efficiently and cost-effectively synthesize high quality silicalite membranes, (5) obtain a new WGS catalyst with activity and selectivity comparable to the best available commercial catalyst with improved chemical stability for  $\text{SO}_2$  and  $\text{H}_2\text{S}$  containing WGS reaction stream, and (6) develop methods to fabricate a tubular membrane support with desired intermediate layers and a membrane module and sealing system for a tubular membrane reactor that can be operated in WGS conditions.

## Results

The work conducted during this reporting period was focused on testing the hydrogen separation performance of silicalite zeolite membranes in a wide temperature range. Decomposition CVD (or thermal cracking) was applied to modify silicalite membranes to improve the  $\text{H}_2$  separation performance at high temperatures. The hydrothermal stability of the modified membranes was also examined. The morphology and thickness of the supported membranes were characterized by scanning electron microscopy (SEM) and X-ray diffraction (XRD).

$\text{H}_2$  separation performance for a silicalite membrane at dry conditions can be seen in Figure 1. The permeances ( $\text{H}_2$ ,  $\text{CO}$ ,  $\text{CO}_2$ ) that are obtained by ternary-component gas separation are quite similar to those for single gas permeation above  $400^\circ\text{C}$ . However, a clear difference between these permeances was observed below  $300^\circ\text{C}$ . The permeances of  $\text{H}_2$  and  $\text{CO}$  for ternary-component gas separation decrease drastically with decreasing temperature, lowering the  $\text{H}_2$  permselectivity.

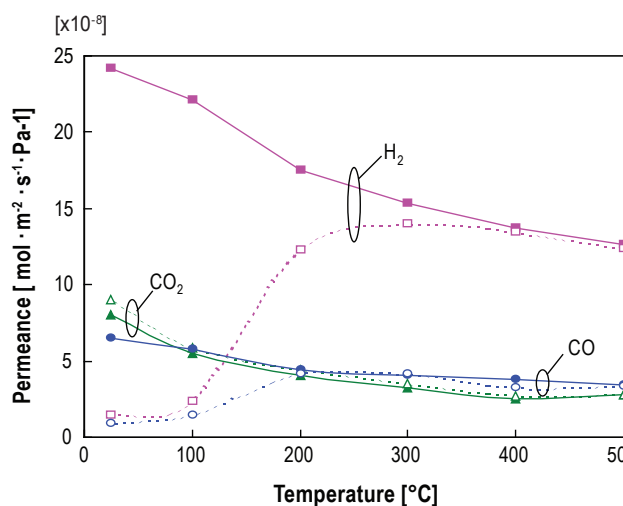

**FIGURE 1.** Temperature dependency of gas permeances for MFI-type zeolite membrane (closed symbols on solid line: gas permeances for single permeation, open symbols on broken line: those for multi-component gas separation), feed composition ( $\text{H}_2:\text{CO}:\text{CO}_2=1:1:1$ ,  $P_{\text{feed}}:0.3\ \text{MPa}$ ,  $P_{\text{permeate}}:0.1\ \text{MPa}$ ).

On the other hand, CO<sub>2</sub> permeance for ternary-component gas separation is similar to that for single gas permeation. It is expected that CO<sub>2</sub> preferential adsorption on zeolitic pores should occur due to much stronger affinity between CO<sub>2</sub> and zeolitic pores than that between H<sub>2</sub> or CO and zeolitic pores. Since CO<sub>2</sub> adsorption on zeolitic pores decreases with increasing temperature, it can be considered that H<sub>2</sub> separation performance for ternary-component gas separation coincides well with that for single gas permeation at high temperature (>400°C). On the other hand, at low temperature, the zeolitic pores are blocked by the adsorbed CO<sub>2</sub> molecules that make H<sub>2</sub> and CO molecules unable to permeate through these pores in the membrane.

An MFI-type zeolite membrane was modified by decomposition CVD (thermal cracking of methyl-diethoxy silane, MDES) in a reducing atmosphere. The surface of the zeolite layer was exposed to MDES at 450°C. MDES appeared to diffuse into zeolite pores and decompose to cause deposition of carbon or silicon in the pores. The zeolite membrane before modification was first tested by p/o-xylene vapor separation at 300°C. The membrane exhibited p/o-xylene a vapor separation factor of approximately nine before modification. After modification, the membrane became non-selective for p/o-xylene and the xylene permeance decreased by two orders of magnitude. This indicates that the zeolite pore size/structure was successfully reduced/modified, and became inaccessible to the both p- and o-xylene molecules.

The modified membrane was then tested by separation of H<sub>2</sub>/CO<sub>2</sub> (50:50) gas mixtures. The results show that the zeolite pore modification by the decomposition CVD dramatically enhanced the separation of H<sub>2</sub>/CO<sub>2</sub> with a moderate decrease of the H<sub>2</sub> permeance. Figure 2 shows the separation of a H<sub>2</sub>/CO<sub>2</sub> 50/50 mixture with 11% and 28% of water vapor

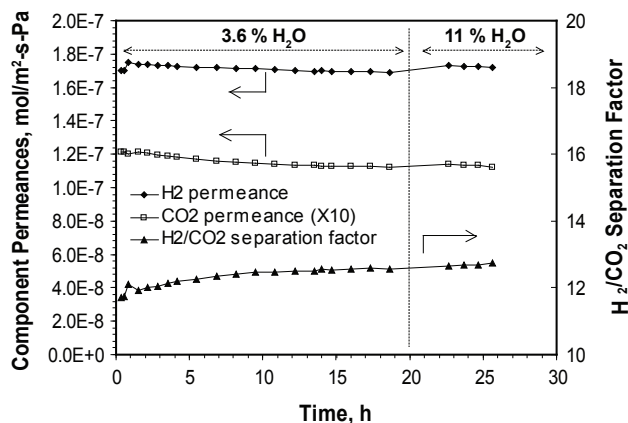

FIGURE 2. Separation of H<sub>2</sub>/CO<sub>2</sub> (50/50) (with Steam Added) for the Modified Membrane

in the feed stream. The membrane exhibits a H<sub>2</sub>/CO<sub>2</sub> selectivity of 13 at 450°C. This result also indicates that the modified membrane is stable at humid operation conditions.

Continuing efforts in developing the microwave heating synthesis method, MFI-type zeolite membranes were synthesized on high quality seed layers with seed crystallite size of 60~120 nm. Template-free synthesis precursors were used for secondary growth to form continuous zeolite membranes, which were successfully obtained from precursors with and without aluminum contents by microwave heating. It was found that 3-4 hours of hydrothermal reaction were sufficient for the secondary growth process under microwave heating, while a 10 to 20-hour reaction time was necessary in conventional heating. It has been also confirmed that aluminum components in the synthesis precursor facilitate secondary growth and a high concentration of SiO<sub>2</sub> is needed for membrane formation in an aluminum-free precursor.

Membrane reactor modules have been assembled incorporating commercially available, custom porous tube (CoorsTek Inc., Golden, CO, USA) with dimension (O.D.×I.D.×length) of 12×10×100 mm. In this reporting period the surrounding framework for the membrane reactor has been put into place including control systems for gas handling, back pressure, temperature, and process characterization. The membrane reactor and its accompanying control systems have been assembled within a rack mount with a centralized computer, which monitors and implements the control systems on a LABView™ 7.1.1 platform.

A schematic diagram of the membrane reactors control components is shown in Figure 3. The steady-state flow rates for the H<sub>2</sub>/CO<sub>2</sub> gaseous feed and N<sub>2</sub> sweep are maintained by mass flow controllers (Brooks Instruments, The Netherlands) with a mild back pressure preserved by combining down stream pressure flow controllers (Brooks Instruments) and

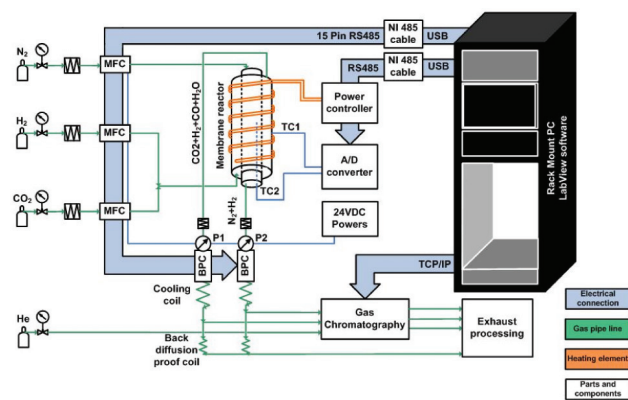

FIGURE 3. A Schematic Diagram of the Membrane Reactor Control Components

precision pressure transducers (MKS, USA). The membrane reactor is heated to temperature by a coiled resistive Kanthal heating element with the internal and element temperature monitored with dedicated type S thermocouples. The membrane reactor's temperature control system is the multi-zone furnace. The composition of the membrane reactor's retentate and permeate streams is examined by gas chromatography (Dual channel CP-4900 Micro-GC, Varian Inc.) where the 10 m, 5 Å molsieve and 10 m poraplot Q column allow accurate determination of CO, CO<sub>2</sub> and H<sub>2</sub>.

The work on catalysis was focused on preparation of a new family of ternary spinel-based catalysts for sulfur-tolerant WGS reaction. The WGS reaction was performed at a low steam-to-CO ratio (S/CO = 1) to study the influence of a steam deficient environment on the activity of the catalysts. Figure 4 shows WGS activity performance over various ferrite-based catalysts at different steam-to-CO ratios. The WGS reaction was performed in the temperature range of 350 to 550°C using a designated amount of steam and CO. In general with increase in temperature from 350 to 550°C, the WGS activity was found to increase. Also the WGS activity was found to increase as the steam-to-CO ratio was increased, particularly from S/CO = 1 to S/CO = 3.5. However, the WGS activity went down slightly for S/CO = 7.0 when compared to S/CO = 3.5 in the case of Fe/Cr catalysts.

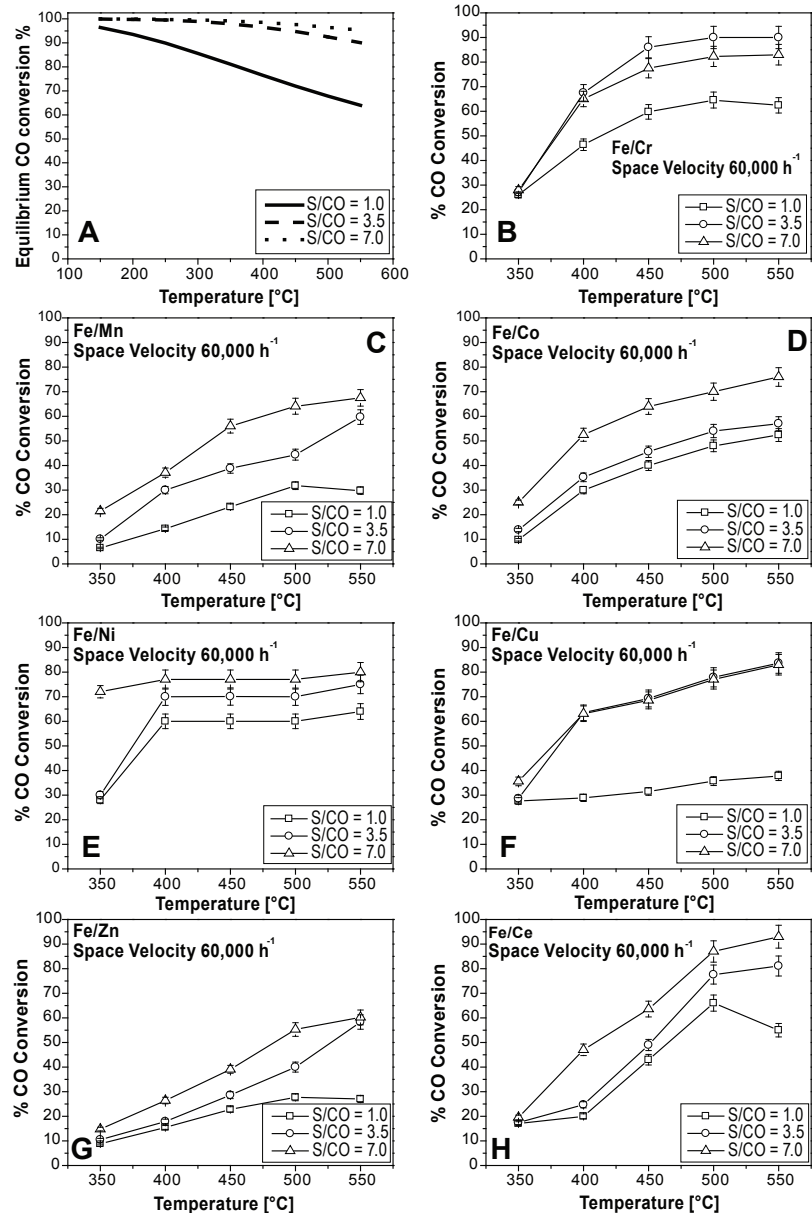

FIGURE 4. WGS Activity Performance over Various Ferrite-Based Catalysts at Different Steam-to-CO Ratios

## Conclusions and Future Directions

- Tested hydrogen separation performance for silicalite membranes in a wide temperature range (25-500°C).
- Developed modified silicalite membranes with high hydrothermal stability ( $H_2$  permeance:  $>1 \times 10^{-7}$  mol/ m<sup>2</sup>·s Pa,  $H_2/CO_2$  permselectivity: 20,  $H_2/CO_2$  separation selectivity: 13).
- Identified the optimum conditions of microwave synthesis for silicalite membranes.
- Designed and realized membrane reactor system.

- Developed membrane support by colloidal casting.
- Developed ternary spinel-based catalysts for sulfur-tolerant WGS reaction.

Future work will include the following tasks.

- Improve  $H_2$  separation performance for silicalite membranes by CVD modification.
- Test hydrogen separation and chemical/hydrothermal stability of silicalite membranes under syngas conditions.

- Develop and design intermediate layer/tube leak/flow testing membrane module.
- Test the performance of sulfur-tolerant hybrid WGS catalyst developed by simulating SO<sub>2</sub> and H<sub>2</sub>S in the feed stream.

## FY 2007 Publications/Presentations

### Journal Papers

1. H. Verweij, Y.S. Lin, and J. Dong, "Micro-porous silica and zeolite membranes for hydrogen purification", *MRS Bull.*, **31**, 756-764 (2006).
2. M. Kanezashi, J. O'Brien and Y.S. Lin, "Template-free synthesis of MFI-type zeolite membranes: Permeation characteristics and thermal stability improvement", *J. Membr. Sci.*, **286** (1-2): 213-222 (2006).
3. K. Shqau, M.L. Mottern, D. Yu, and H. Verweij, "Preparation and properties of porous  $\alpha$ -Al<sub>2</sub>O<sub>3</sub> membrane supports", *J. Am. Ceram. Soc.*, **89** [6] 1790-94 (2006).
4. M. Kanezashi, J. O'Brien and Y.S. Lin, "Thermal stability improvement of MFI-type zeolite membranes with doped zirconia intermediate layer", *Micropor. Mesopor. Mater.*, **103**, 302-308 (2007).
5. T.A. Kuzniatsova, Y.H. Kim, K. Shqau, P.K. Dutta, and H. Verweij, "Zeta potential measurements of zeolite Y: application in homogeneous deposition of particle coatings," *Micropor. Mesopor. Mater.*, **103**, 102-107 (2007).
6. M.L. Mottern, K. Shqau, J.Y. Shi, D. Yu, and H. Verweij, "Thin supported inorganic membranes for energy-related gas and water purification," *Int. J. Hydrogen Techn.*, in press, (2007).
7. J. O'Brien-Abraham, M. Kanezashi and Y.S. Lin, "A comparative study on permeation and mechanical properties of random and oriented MFI-type zeolite membranes", *Micropor. Mesopor. Mater.*, in press (2007).
8. A. Khan and P.G. Smirniotis, "Modified ferrite-based shift catalysts for ultra high temperature membrane reactor applications," *Journal of Catalysis*, submitted (2007).
9. X. Gu, Z. Tang, J. Dong, "On-stream modification of MFI zeolite membranes for enhancing gas separation at high temperature", *Micropor. Mesopor. Mater.*, submitted (2007).
10. Z. Tang, X. Gu, J. Dong, "Microwave Synthesis of MFI-Type Zeolite Membranes by Secondary Growth Using Organic-Free Precursor Solutions," *J. Membr. Sci.*, Submitted (2007).

### Proceedings/Book Chapters

1. M. Kanezashi, J. O'Brien, H. Zou and Y.S. Lin, "Permeation and Separation Characteristics of Silicalite Membranes on Porous Alumina Support by Template-Free Secondary Growth Method", *Proc. 9<sup>th</sup> Internal. Conf. on Inorganic Membranes*, R. Bredesen and H. Ræder (Eds), pp. 591-594 (2006).

2. M.L. Mottern, J.Y. Shi, K. Shqau, D. Yu, and H. Verweij, "Micro-structural optimization of thin supported inorganic membranes for gas and water purification," in *Membranes: Manufacturing and Applications*, Norman N. Li, Anthony G. Fane, W.S. Winston Ho, and Takeshi Matsuura, eds., John Wiley & Sons, New York, (in press) (2007).
3. J. L. O'Brien-Abraham, M. Kanezashi, Y.S. Lin, "Effect of microstructure of MFI-type zeolite membranes on separation of xylene isomers", *Proc. 15<sup>th</sup> International Zeolite Conf.*, in press (2007).
4. J.Y. Shi, K. Shqau, H. Verweij, R. Revur, S. Sengupta, and J.R. Schorr, "Preparation of well-defined thin YSZ and SSZ membranes with a narrow pore size distribution," *Proceedings 9<sup>th</sup> International Conf. on Inorganic Membranes*, R. Bredesen and H. Ræder (Eds), pp. 69-73 (2006).
5. M.L. Mottern, K. Shqau, D. Yu and H. Verweij, "A closer examination of permeation porometry," *Proceedings 9<sup>th</sup> International Conf. on Inorganic Membranes*, R. Bredesen and H. Ræder (Eds), pp. 118-123 (2006).
6. D. Yu, M.L. Mottern, K. Shqau, and H. Verweij, "Synthesis and Optimization of supported  $\gamma$ -alumina membranes for water purification," *Proceedings 9<sup>th</sup> International Conf. on Inorganic Membranes*, R. Bredesen and H. Ræder (Eds), pp. 691-695 (2006).

### Conference Presentations

1. J. O'Brien, M. Kanezashi and Y.S. Lin, "Separation of xylene isomers by pervaporation through MFI-zeolite membranes of varying microstructure," The 17<sup>th</sup> North American Membrane Society Annual Meeting, Chicago, U.S.A. (2006).
2. H. Verweij, "Inorganic membranes for energy-related gas separation and water purification," Virginia Tech, Department of Chemical Engineering, April 3, 2006.
3. H. Verweij, "Clean Energy Research at OSU," 12<sup>th</sup> Annual Coalition for National Science Funding, Exhibition & Reception, Washington, DC, June 7, 2006.
4. Khan and P.G. Smirniotis, "Modified Ferrite Based Catalysts for Ultra-High Temperature Water Gas Shift Reaction for Membrane Reactor Applications" AIChE Annual Meeting, San Francisco, Nov. 12-17, 2006.
5. M. Kanezashi, J. O'Brien and Y.S. Lin, "Permeation and separation characteristics of MFI type zeolite membranes on zirconia intermediate layer by template-free secondary growth method," AIChE Annual Meeting, San Francisco, Nov. 12-17, 2006.
6. X. Gu, J. Dong, and T.M. Nenoff, "Effect of intercrystalline pores in MFI zeolite membranes on xylene separation and membrane improvement by online coking," AIChE Annual Meeting, San Francisco, CA, USA, Nov. 12-17, 2006.
7. T.A. Kuzniatsova, M.L. Mottern, M.C. Schillo, K. Shqau, D. Yu, and H. Verweij, "Application of inorganic membranes in energy conversion technology," TMS 135<sup>th</sup> Annual Meeting, Orlando, FL, March 12-16, 2007.