



U.S. Department  
of Transportation  
**Federal Highway  
Administration**

400 Seventh St., S.W.  
Washington, D.C. 20590

In Reply Refer To: HSA-10/SS-131

Mr. Larry Leahy  
President  
Xcessories Squared  
P.O. Box 135  
Auburn, Illinois 62615

Dear Mr. Leahy:

Thank you for your letter of September 30, 2005, requesting the Federal Highway Administration (FHWA) acceptance of your company's "Kleen Break" sign post coupler as a breakaway system for use on the National Highway System (NHS). Accompanying your letter was a letter report from E-TECH Testing Services and videos of the pendulum tests. You requested that we find the Kleen Break sign post coupler acceptable for use on the NHS under the provisions of the National Cooperative Highway Research Program (NCHRP) Report 350 "Recommended Procedures for the Safety Performance Evaluation of Highway Features." On November 15, 2005, you submitted additional support from E-TECH regarding the expected performance when three posts are struck within a 2.1 m span.

### **Introduction**

Testing of the supports was in compliance with the guidelines contained in the NCHRP Report 350, Recommended Procedures for the Safety Performance Evaluation of Highway Features. Requirements for breakaway supports are those in the American Association of State Highway and Transportation Officials' Standard Specifications for Structural Supports for Highway Signs, Luminaires and Traffic Signals.

A brief description of the test article follows:

The "Kleen Break" (Model 425) Coupler consists of two ductile iron components, a top half and a bottom half joined together with a 5/8" – 11 UNC shear bolt using a lock washer, flange nut and a 80 durometer rubber bushing. The bottom end of the shear bolt is threaded to secure the assembled coupler to the anchor plate, while the top end of the bolt is threaded to receive the 5/8" flange nut, thus connecting the anchor and both halves of the coupler together. The 0.425" neck down of the bolt is now situated at the indexable seam of the top and bottom halves of the connector with the rubber bushing encasing the mid section of the bolt while



being compressed between the coupler halves (see drawing numbers 101303A and 101203A enclosed for reference). The sign post is then secured into the top half with a ductile iron-locking wedge that normally is still in place after impact. The serrated interlocking teeth allow for 360 degrees rotation of the sign post after the anchor is embedded.

For each tested sign post, the lower half of the support coupling was mounted to a 50.8 mm square 4.6 mm thick (7 ga) perforated tube ground anchor, and the upper half was placed on a 44.5 mm square 1.9 mm thick (14 ga) perforated tube support upright. The ground anchor was equipped with a 305 mm x 330 mm x 3.4 mm thick (10 ga) soil bearing plate and embedded in compacted the NCHRP Report 350 Standard Soil (“strong” soil.)

For the single post test the upright was outfitted with a 914 mm tall x 762 mm wide 2 mm thick aluminum sign. The base of the sign was a nominal 2134 mm above ground level. The support was torqued and locked according to the manufacturer’s specifications. The mass of the support with sign was 12.7 kg. For the dual post test the uprights were fitted with a 1524 mm tall x 1219 mm side x 2 mm thick aluminum sign. The base of the sign was a nominal 2134 mm above the ground level. The supports were torqued and locked according to the manufacturers specifications. The mass of the support with sign was 31.6 kg.

### Testing

Pendulum testing was conducted on your company’s devices. The mass of the test bogie was 845 kg in both tests. The 10 stage crushable FOIL bogie nose was used. The complete devices as tested are shown in the enclosures.

Test #	Speed	Version	Neck Diameter	Occupant Impact	Delta V
1	35.0 kmh	Single	10.8 mm (0.425 in)	None (no contact)	0.29 m/s
2	35.0 kmh	Dual	10.8 mm (0.425 in)	None (no contact)	0.58 m/s

In both tests the remaining stub height was less than 30 mm.

### Findings

The results of testing met the FHWA velocity change and stub height requirements and, therefore, the devices described above and shown in the enclosed drawings for reference are acceptable for use as Test Level 3 devices on the NHS under the range of conditions tested, when proposed by a State.

The pendulum test program tested single and dual supports. Because of the low velocity change you requested that the system be found acceptable when up to three posts within a span of 2.1 m are used to support a sign. We requested an engineering analysis to support that request and subsequently you provided E-TECH Testing Services’ calculations. The E-TECH concluded that the dual and triple post systems would tend to rotate about their center of gravity. This means that the majority of the additional velocity change would be due primarily to the resistance of the couplers to breaking, and very little would be due to the additional mass of the 3-post system.

Their calculations showed the expected Delta V to be less than 1.0 m/s. Therefore, the Kleen Break system may be used with one, two, or three posts within a seven-foot span.

Please note the following standard provisions that apply to the FHWA letters of acceptance:

- Our acceptance is limited to the crashworthiness characteristics of the devices and does not cover their structural features, nor conformity with the Manual on Uniform Traffic Control Devices.
- Any changes that may adversely influence the crashworthiness of the device will require a new acceptance letter.
- Should the FHWA discover that the qualification testing was flawed, that in-service performance reveals unacceptable safety problems, or that the device being marketed is significantly different from the version that was crash tested, it reserves the right to modify or revoke its acceptance.
- You will be expected to supply potential users with sufficient information on design and installation requirements to ensure proper performance.
- You will be expected to certify to potential users that the hardware furnished has essentially the same chemistry, mechanical properties, and geometry as that submitted for acceptance, and that they will meet the crashworthiness requirements of the FHWA and the NCHRP Report 350.
- To prevent misunderstanding by others, this letter of acceptance, designated as number SS-131 shall not be reproduced except in full. As this letter and the supporting documentation which support it become public information, it will be available for inspection at our office by interested parties.
- The Kleen Break system is a patented device and is considered "proprietary." When proprietary devices are *specified by a highway agency* for use on Federal-aid projects they: (a) must be supplied through competitive bidding with equally suitable unpatented items; (b) the highway agency must certify that they are essential for synchronization with existing highway facilities or that no equally suitable alternative exists or; (c) they must be used for research or for a distinctive type of construction on relatively short sections of road for experimental purposes. Our regulations concerning proprietary products are contained in Title 23, Code of Federal Regulations, Section 635.411, a copy of which is enclosed.
- This acceptance letter shall not be construed as authorization or consent by the FHWA to use, manufacture, or sell any patented device for which the applicant is not the patent holder. The acceptance letter is limited to the crashworthiness characteristics of the candidate device, and the FHWA is neither prepared nor required to become involved in issues concerning patent law. Patent issues, if any, are to be resolved by the applicant.

Sincerely yours,

John R. Baxter, P.E.  
Director, Office of Safety Design  
Office of Safety

Enclosures

FHWA:HSA-10:NArtimovich:tb:x61331:12/1/05

File: h://directory folder/artimovich/SS193-XcessoriesFIN.doc

cc: HSA-10 (Reader, HSA-1; Chron File, HSA-10;  
N.Artimovich, HSA-10)

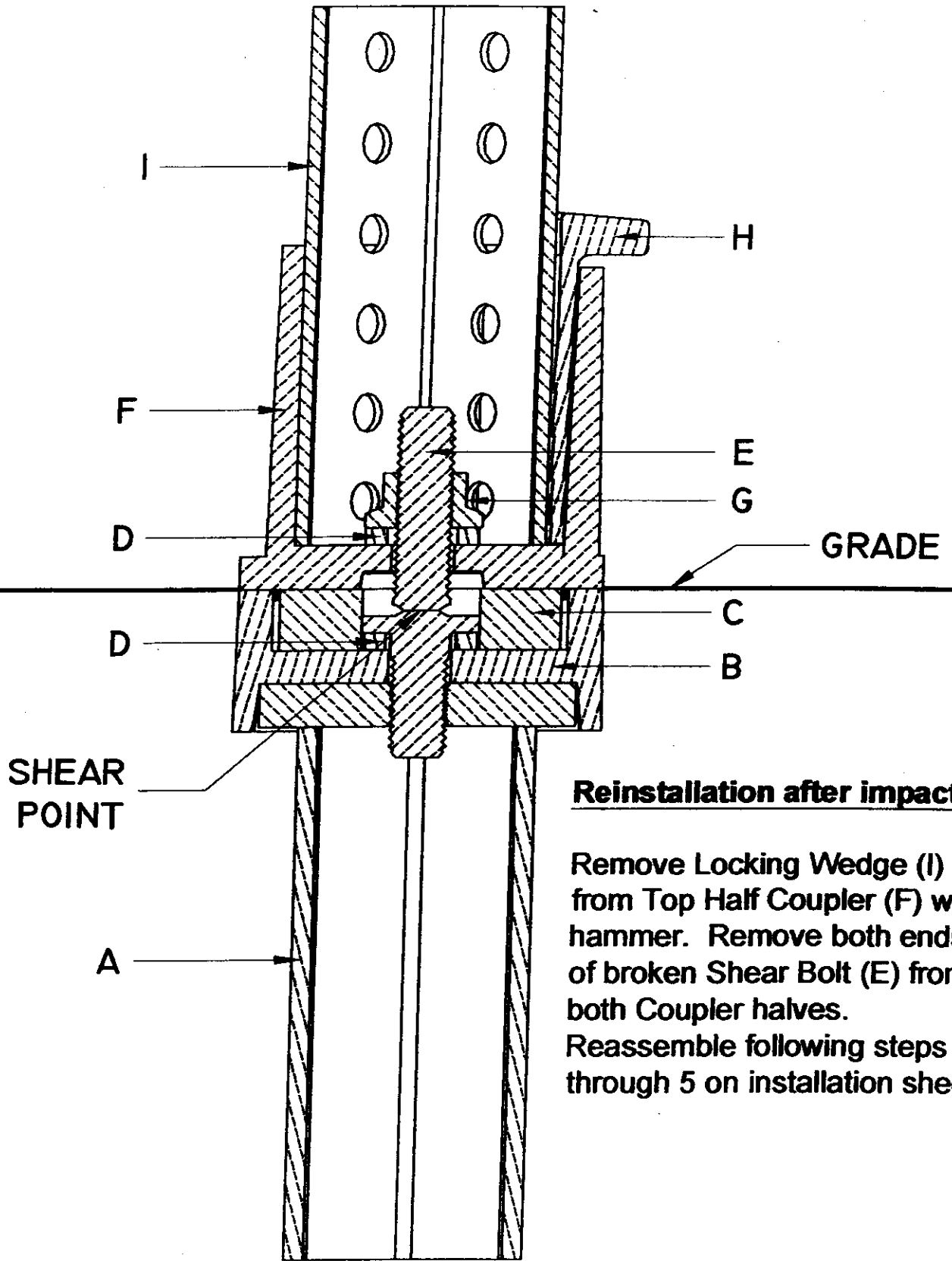

**Reinstallation after impact**

Remove Locking Wedge (I) from Top Half Coupler (F) with hammer. Remove both ends of broken Shear Bolt (E) from both Coupler halves. Reassemble following steps 2 through 5 on installation sheet.

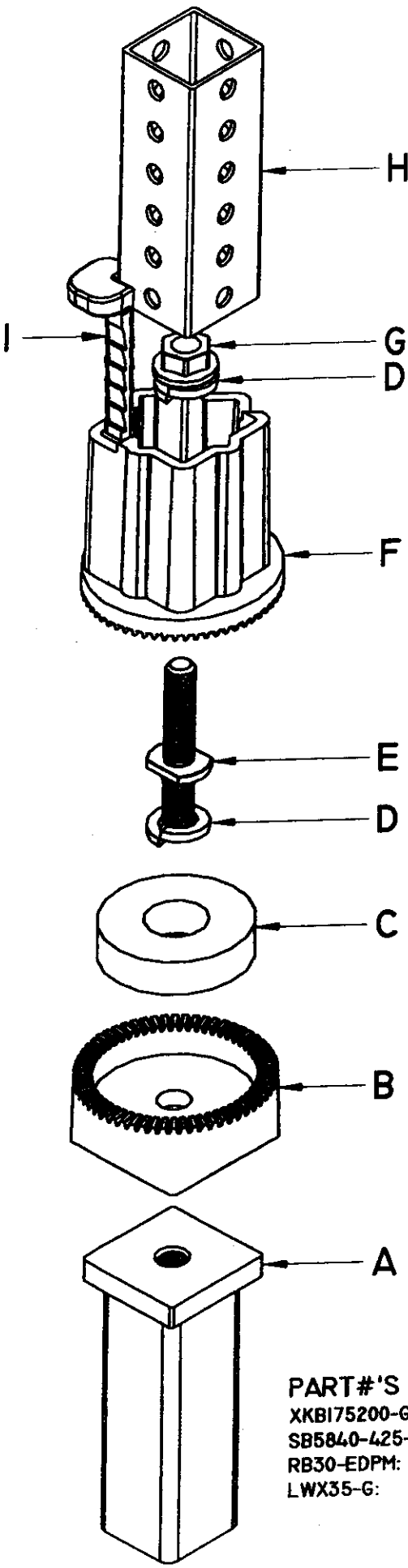

TOOLS NEEDED:  $\frac{5}{16}$ " SOCKET, 1" OPEN END WRENCH AND 16 OZ. HAMMER

**STEP 1** After anchor (A) is in place (countersunk approximately 1" to grade), set the Bottom Half Coupler (B) onto the threaded plate of the Anchor (A).

*Note:* The top of the Bottom half Coupler (B) to be flush with grade.

**STEP 2** Drop Shear Bolt (E) with lock washer (D) under the shoulder, into Bottom Half Coupler (B), short end of Shear bolt (E) will be the portion to go into Anchor (A). Tighten Shear Bolt (E) using an open end wrench on flats of the shoulder until Lock Washer (D) is fully compressed.

**STEP 3** Slide the Rubber Bushing (C) over the secured Shear Bolt (E) until seated in the round cavity of the Bottom Half Coupler (B).

**STEP 4** Mesh the Top Half Coupler (F) onto the Bottom Half Coupler (B) allowing top threads of Shear Bolt (E) to extend up through the hole in the floor of the Top Half Coupler (F). Thread the nut (G) onto the top threaded portion of the Shear Bolt (E) and tighten with a ratchet until the matching, serrated teeth of Top Half Coupler (F) and Bottom Half Coupler (B) are fully meshed and Rubber Bushing (C) is fully compressed.

*Note:* The matching Serrations of the Top Half Coupler (F) and Bottom Half Coupler (B) allow for indexing of the sign support 360°.

**STEP 5** Insert the Sign Support (H) into the Top Half Coupler (F). With a hammer drive the Sign Support Locking Wedge (I) between Sign Support (H) and Top Half Coupler (F) at pre-determined location until seated in corresponding depression of Top Half Coupler (F).

*Note:* This Sign Support Locking Wedge (I) will keep Sign Support (H) secure without need of additional fasteners or hardware.

## PARTS LIST

A	ANCHOR
B	BOTTOM HALF COUPLER
C	RUBBER BUSHING
D	LOCK WASHER
E	SHEAR BOLT
F	TOP HALF COUPLER
G	$\frac{5}{8}$ "-11 SERRATED FLANGE NUT
H	SIGN SUPPORT
I	SIGN SUPPORT LOCKING WEDGE

**PART #'S**  
 XKBI75200-G:  
 SB5840-425-Z:  
 RB30-EDPM:  
 LWX35-G:

COMPLETE ASSEMBLY CONSISTS OF ABOVE PARTS B,C,D,E,F,G & I  
 BOLT SET CONSISTS OF ABOVE PARTS D, E & G  
 IS ABOVE PART C  
 IS ABOVE PART I

REFERENCE PRICELIST DATED MARCH 5, 2005