

LA-UR-06-5710

Approved for public release;  
distribution is unlimited.

<i>Title:</i>	MULTIPLE STRESS COMPONENTS FROM MULTIPLE CUTS FOR THE CONTOUR METHOD
<i>Author(s):</i>	Pierluigi Pagliaro (WT-2) Michael B. Prime (WT-2) Bernardo Zuccarelli
<i>Intended for:</i>	Associazione Italiana per l'Analisi delle Sollecitazioni (AIAS) XXXV Convegno Nazionale – 13-16 Settembre 2006, Università Politecnica delle Marche



Los Alamos National Laboratory, an affirmative action/equal opportunity employer, is operated by the Los Alamos National Security, LLC for the National Nuclear Security Administration of the U.S. Department of Energy under contract DE-AC52-06NA25396. By acceptance of this article, the publisher recognizes that the U.S. Government retains a nonexclusive, royalty-free license to publish or reproduce the published form of this contribution, or to allow others to do so, for U.S. Government purposes. Los Alamos National Laboratory requests that the publisher identify this article as work performed under the auspices of the U.S. Department of Energy. Los Alamos National Laboratory strongly supports academic freedom and a researcher's right to publish; as an institution, however, the Laboratory does not endorse the viewpoint of a publication or guarantee its technical correctness.

## MULTIPLE STRESS COMPONENTS FROM MULTIPLE CUTS FOR THE CONTOUR METHOD

*P. Pagliaro<sup>a\*</sup>, M. B. Prime<sup>b</sup>, B. Zuccarello<sup>a</sup>*

<sup>a</sup> Dipartimento di Meccanica, Università degli Studi di Palermo, Viale delle Scienze, 90128 Palermo

<sup>b</sup> Los Alamos National Laboratory, Los Alamos, New Mexico 87545, USA

### Sommario

Il “contour method” è un metodo meccanico di analisi sperimentale delle tensioni residue basato sul taglio accurato del componente da esaminare mediante elettroerosione a filo (EDM). A partire dal rilievo delle superfici di taglio, le tensioni residue normali al piano di taglio sono calcolate utilizzando un semplice modello FEM del componente tagliato a cui sono imposti gli spostamenti fuori dal piano rilevati sperimentalmente. In questa memoria viene presentata una estensione del contour method che permette la misura di differenti componenti delle tensioni residue eseguendo differenti tagli successivi. In dettaglio, nel metodo proposto, dopo il primo taglio ed il rilievo della corrispondente superficie, le due metà del componente sono tagliate nuovamente lungo direzioni trasversali ed i contorni delle superfici di taglio sono nuovamente rilevati. Al fine di tenere conto della influenza del primo taglio, le tensioni calcolate sui piani di taglio successivi al primo sono opportunamente combinate con le informazioni ottenute con il primo taglio, in modo da ottenere la ricostruzione della distribuzione iniziale delle tensioni residue. Il metodo proposto è stato applicato all'analisi delle tensioni residue presenti in una piastra di acciaio microlegato (HSLA) temprato.

### Abstract

An extension of the contour method is presented which allows the measurement of multiple stress components by making multiple cuts. In the contour method, a body is carefully cut in two using wire electric discharge machining (EDM). The contours, or shapes, of the cut surfaces are then measured and used to calculate the original residual stress normal to the cut plane using a simple finite element calculation. In the extension presented here, the two pieces from the original body are cut again in a transverse direction, and the contours of the cut surfaces are measured again. The stresses calculated on the planes of these second cuts are affected by the first cut. Then a simple reconstruction using information already provided by the calculation for the first cut gives the original (prior to the first cut) stresses on the plane of the subsequent cuts. The method is demonstrated on a plate of quenched High-Strength Low-Alloy steel, revealing the approximately biaxial quenching stresses.

**Key words:** residual stress, contour method.

### 1. INTRODUCTION

Residual stresses play a significant role in many materials failure process like fatigue, fracture, stress corrosion cracking, buckling and distortion. Residual stresses are the stresses present in a part free from any external load, and they are generated by virtually any manufacturing process. Because of their important contribution to failure and their almost universal presence, the knowledge of residual stress is crucial for prediction of the strength of any engineering structure. A big research effort is

focused on this task. However, the knowledge of residual stresses is a very complex problem. In fact, the development of residual stress generally involves nonlinear material behavior, phase transformation, coupled mechanical and thermal problems and also different mechanical properties throughout the material. So, the ability to accurately quantify residual stresses through measurement is an important engineering tool. Recently, a new method for measuring residual stress, the contour method [1, 2], has been introduced. In the contour method, a part is carefully cut in two along a flat plane causing the residual stress normal to the cut plane to relax. The contour of each of the opposing surfaces created by the cut is then measured. The deviation of the surface contours from planarity is assumed to be caused by elastic relaxation of residual stresses and is therefore used to calculate the original residual stresses. One of the unique strengths of this method is that it provides a full cross-sectional (two-dimensional) map of the residual stress component normal to the cross section. The only common methods that can measure similar 2-D stress maps have significant limitations [3]. The neutron diffraction method is nondestructive but sensitive to micro-structural changes [4], time consuming, and limited in maximum specimen size, about 50 mm, and minimum spatial resolution, about 1mm. Sectioning methods [3] are experimentally cumbersome, analytically complex, error prone, and have limited spatial resolution, about 1 cm. Other relaxation methods, at least those that are commonly used, determine at most a one-dimensional depth profile [5], although some can measure multiple stress components [6]. A limitation of the contour method is that only one residual stress component is determined from the measurement.

In order to extend the capability of contour method to measure multiple residual stress components, a new theoretical development is presented in this paper to obtain other normal stress components. The proposed method involves making multiple cuts, but the original residual stresses, prior to the first cut, are reconstructed on all cut planes. An experimental test to validate the theory is presented. Multiple cuts have been used previously to measure multiple stress components with the contour method [7], but instead of reconstructing the original stresses the results were compared to finite element simulations of the manufacturing process where the effect of the multiple cuts were also simulated. Another approach for measuring multiple components with the contour method involves making additional cuts at 45 degrees from the first cut, assuming a continually processed part, and calculating the full original stress tensor on the first cut plane [8]. The method proposed in this paper provides a complementary option for determining multiple stress components.

## 1. THEORY

### 1.1 First cut

Before introducing the new theory for multiple cuts, the original theory for the first cut is reviewed. The contour method [1, 2] is based on a variation of Bueckner's superposition principle [9]. Figure 1 presents an illustration in 2-D for simplicity, although the principle applies equally in 3-D.

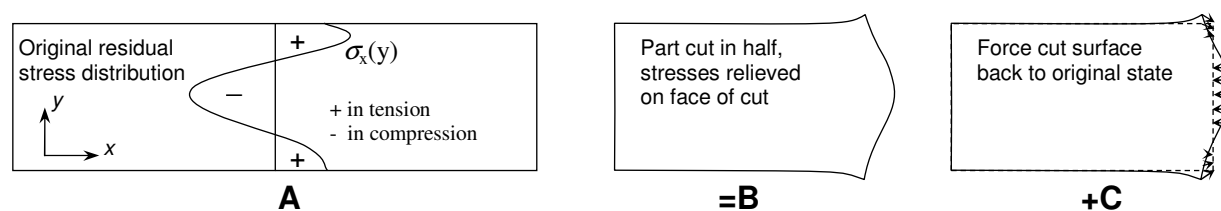

**Figure 1** Superposition principle to calculate residual stresses from surface contour measured after cutting the part in two.

In A, the part is in the undisturbed state containing the residual stress to be determined. In B, the part has been cut in two and has deformed because of the residual stresses released by the cut. In C, the free surface created by the cut is forced back to its original flat shape. Superimposing the stress state in B with the change in stress from C would give the original residual stress throughout the part, as shown by the following expression:

$$\sigma^{(A)} = \sigma^{(B)} + \sigma^{(C)} \quad (1)$$

This superposition principle assumes elastic relaxation of the material and that the cut process does not introduce stress that could affect the measured contour. With proper application of this principle it is possible to determine the residual stress over the plane of the cut. Experimentally, the contour of the free surface is measured after the cut and analytically the surface of a stress-free model is forced back to its original flat configuration by applying the opposite of the measured contour as boundary conditions. Because the stresses in B are unknown, one cannot obtain the original stress throughout the body. However, the normal and shear stresses on the free surface in B must be zero ( $\sigma_x$ ,  $\tau_{xy}$  and  $\tau_{xz}$ ). Therefore, step C by itself will give the correct stresses along the plane of the cut:

$$\begin{aligned}\sigma_x^{(A)} &= \sigma_x^{(C)} \\ \tau_{xy}^{(A)} &= \tau_{xy}^{(C)} \\ \tau_{xz}^{(A)} &= \tau_{xz}^{(C)}\end{aligned}\quad (2)$$

The described superposition principle uniquely determines the original  $\sigma_x$ ,  $\tau_{xy}$  and  $\tau_{xz}$  residual stress distribution on the plane of the cut. In fact, the analytical solution (step C) specifies conditions on all boundaries of the body. In detail, displacements are specified on the cut plane, and the other surfaces are stress free. Therefore, by the Kirchoff's boundary value problem [10], the solution for the stress state in the elastic body is unique. Since the solution is unique and the application of the contour as boundary conditions gives us the original distribution of the  $\sigma_x$ ,  $\tau_{xy}$  and  $\tau_{xz}$  on the cut plane, conversely the relaxed contour after the cut is only caused by the relaxation of the original  $\sigma_x$ ,  $\tau_{xy}$  and  $\tau_{xz}$  on the cut plane. Stresses in the body away from the cut plane and the transverse stresses  $\sigma_y$ ,  $\sigma_z$  and  $\tau_{yz}$  on the cut plane will not have any influence on the measured contour (step B). For this reason, step C does not determine the original value of these stresses throughout the body but only the change in all the stresses throughout the part.

In practice, only the normal stress component  $\sigma_x$  can be experimentally determined. The experimental measurement of the contour only provides information about the displacements in the normal (x) direction, not those in the transverse (y) direction. Therefore, the surface is forced back to the original flat configuration (step C) in the x-direction only. The shear stresses ( $\tau_{xy}$  and  $\tau_{xz}$ ) are constrained to zero in the solution. The stress-free constraint is automatically enforced in most implicit, structural, finite-element analyses if the transverse displacements are left unconstrained. Even if residual shear stresses were present on the cut plane, averaging the contours measured on the two halves of part still lead to the correct determination of the normal stress  $\sigma_x$  [1].

A small convenience is taken in the data analysis by finite element modeling. Modeling the deformed shape of the part for step C in Figure 1 would be tedious. Instead, the surface is flat in the finite element model, and then the part is deformed into the shape opposite of the measured contour. Because the deformations are quite small, the same answer is obtained but with less effort.

## 1.2 Multiple cuts

Once the original part has been cut in two and the original  $\sigma_x$  residual stress on the cut plane is obtained, it is also possible to evaluate the other original  $\sigma_z$  (or  $\sigma_y$ ) residual stresses on a different plane by making additional cuts. The initial analysis of data from an additional cut provides a map of stresses after the first cut, which in the neighborhood of the first cut have changed from their original values. Fortunately, the same calculation that provides  $\sigma_x$  from the first cut also provides all the necessary information to reconstruct the original (before the first cut – step A in figure 2) stresses on the plane of the second cut.

Figure 2 illustrates the theory for reconstructing the original residual stresses on the plane of the second cut. The steps A, B and C are as described above for Figure 1. In D, the part has been cut another time in two along a plane perpendicular to the first cut plane and normal to the z-direction.

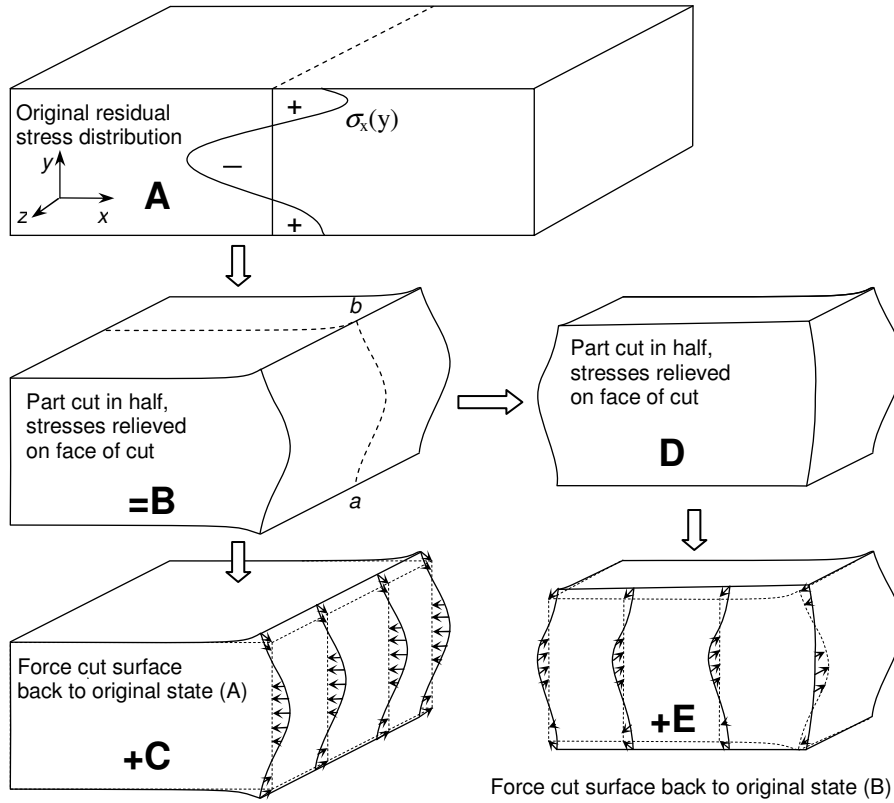

Figure 2 Multiple Stress-Component Superposition Principle

It has deformed because of the residual stresses released by the cut. In E, the free surface created by the second cut is forced back to the original shape before the second cut (step B). Since the stress state in B is given by superimposing the stress state in D with the change in stress from E (as described for the first cut), the original residual stress throughout the part in A, is given by the sum of the stress state in D, E and C, as shown by the following expression:

$$\sigma^{(A)} = \sigma^{(B)} + \sigma^{(C)} = \sigma^{(D)} + \sigma^{(E)} + \sigma^{(C)} \quad (3)$$

Because the stresses in D are unknown, for the same reason described above, one cannot obtain the original stress throughout the body. However, the normal and shear stresses on the free surface in D must be zero ( $\sigma_z$ ,  $\tau_{zx}$  and  $\tau_{zy}$ ). Therefore, the sum of step E, (equal to step B on the cut surface) and step C will give the correct stresses along the plane of the second cut:

$$\begin{aligned} \sigma_z^{(A)} &= \sigma_z^{(E)} + \sigma_z^{(C)} \\ \tau_{zx}^{(A)} &= \tau_{zx}^{(E)} + \tau_{zx}^{(C)} \\ \tau_{zy}^{(A)} &= \tau_{zy}^{(E)} + \tau_{zy}^{(C)} \end{aligned} \quad (4)$$

Obviously, as described before, the solution is already unique, but only the normal stress component  $\sigma_z$  can be experimentally determined.

With this superposition principle, it is possible to evaluate the  $\sigma_x$  and  $\sigma_z$  residual stresses respectively along two different cut planes. Since these two planes have a line in common ( $a$ - $b$  line in Figure 2), along this line the  $\sigma_x$  and  $\sigma_z$  stress distributions are both determined. Unfortunately, stresses on the edge of the cut are the most uncertain for the contour method, so this is not the best location to get accurate results.

The same procedure can be applied to obtain the  $\sigma_y$  component, if the cut will be made along a plane normal to the y-direction instead in the z-direction, or it is also possible to cut in two the part in D and then apply another time the same superposition principle. In this way, it is possible to obtain the  $\sigma_x$ ,  $\sigma_z$  and  $\sigma_y$  maps respectively along three perpendicular planes. Since these planes have one point in common, only at this point (the geometrical center of the plate) are the three normal stress components  $\sigma_x$ ,  $\sigma_z$  and  $\sigma_y$  all determined.

## 2. METHODS

### 2.1 Experiments

The plate material tested in this study was a low carbon, copper precipitation-hardened, High-Strength Low-Alloy steel: HSLA-100. This steel is used for naval ship hulls, armor, and containment vessels. The chemical composition is given in Table 1. The 60.75 mm thick plate material was prepared by hot cross-rolling. It was austenitized at 900 °C for 75 minutes and then water quenched. The plate was then tempered at 660 °C for 200 minutes followed by another water quench. The specification for this material does not allow thermal stress relief because of potential loss of strength. Therefore, the quenching stresses can be expected for all uses of this material. Mechanical testing gave yield strengths of 690 MPa in the final rolling direction and 685 MPa in the transverse direction, with corresponding ultimate strength of 813 MPa and 829 MPa, respectively. A section of plate measuring 151.6 mm and 301 mm long was saw cut from a larger plate for this measurement of residual stress (see Figure 3).

**Table 1.** Alloying elements of HSLA-100 steel plate in weight-%

C	Mn	P	S	Cu	Si	Ni	Cr	Mo	V	Ti	Al
0.06	0.85	0.005	0.002	1.56	0.26	3.45	0.56	0.58	0.003	0.001	0.025

The specimen was cut in half on the first measurement plane indicated in Figure 3 using wire electric discharge machining (EDM) and a 150  $\mu\text{m}$  diameter brass wire. The part was submerged in temperature-controlled deionized water throughout the cutting process. “Skim cut” settings, which are normally used for better precision and a finer surface finish, were used because they also minimize any recast layer and cutting-induced stresses [11]. Because the part deforms during the cutting as stresses are relaxed, the cut could deviate from the original cut plane, which would cause errors in the measured stresses. Therefore, the part was constrained by clamping it on both sides of the cut to a steel plate, which was in turn clamped in the EDM machine (see Figure 4). To prevent any thermal stresses, the specimen and the fixture were allowed to come to thermal equilibrium in the water tank before clamping.

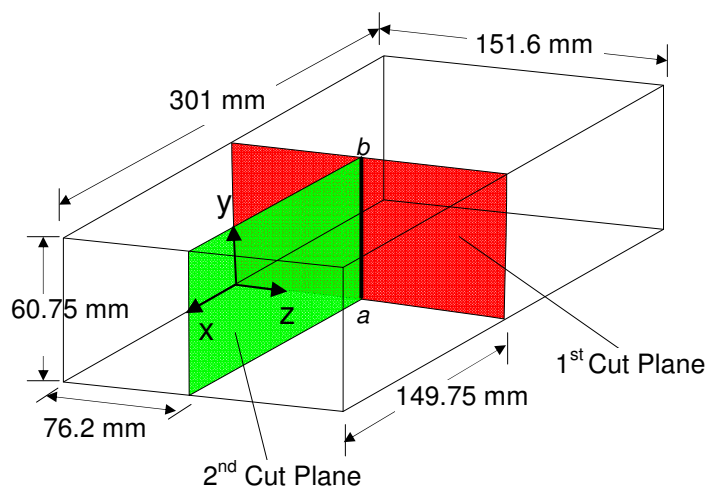

**Figure 3** Dimension of the specimen and cut locations.

After cutting, the plate was removed from the clamping fixture. The contours of both surfaces were measured using a MS Impact II coordinate measuring machine (CMM), an inspection tool that uses a touch probe. A 1mm diameter spherical ruby tip was used on the probe. The cut surfaces were measured on a 0.5 mm spaced grid, giving about 36.500 points on each cut surface.

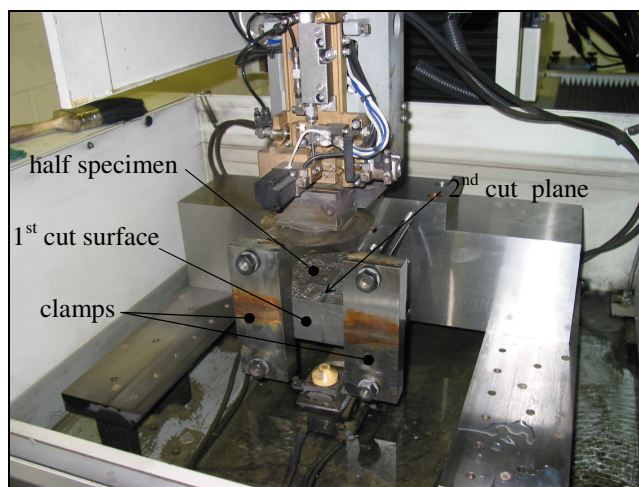

**Figure 4** Half of the original specimen and the clamping fixture to execute the 2<sup>nd</sup> cut on the EDM machine.

Figure 4 shows the front half of the specimen being cut in half another time along the second cut plane shown in Figure 3. The procedure, the machine and the working conditions were the same of the first cut. After cutting, the plate was removed from the clamping fixture. The contours of both surfaces were measured by a different CMM machine, this time using a non-contact probe (see Figure 5). The specimen was scanned using rows separated by 0.5 mm with data points within a row sampled every 0.095 mm, giving about 171.000 points on each cut surface.

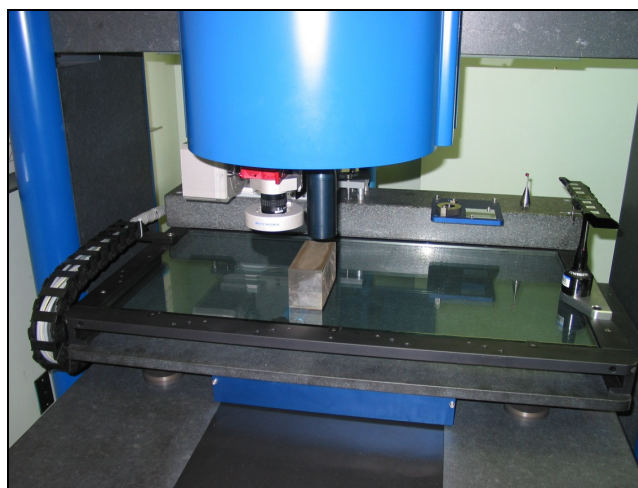

**Figure 5** Part being scanned in Coordinate Measuring Machine using non-contact probe.

## 2.1 Calculations

The procedure for analyzing the data to calculate stresses is presented in more detail elsewhere [12]. The relevant details for this experiment are presented here.

Figure 6a shows the average of the contours measured on the two opposing surfaces created by the first cut and then smoothed by fitting the data to a surface using bivariate smoothing spline [12]. The peak-to-valley amplitude of the contour is about 50  $\mu\text{m}$ . The primary shape of the contour is low in the mid-thickness of the plate and higher toward the top and bottom. Figure 6b shows the same result for



the second cut. The peak-to-valley amplitude of the contour is about  $50\ \mu\text{m}$ , very close to the first cut surface.

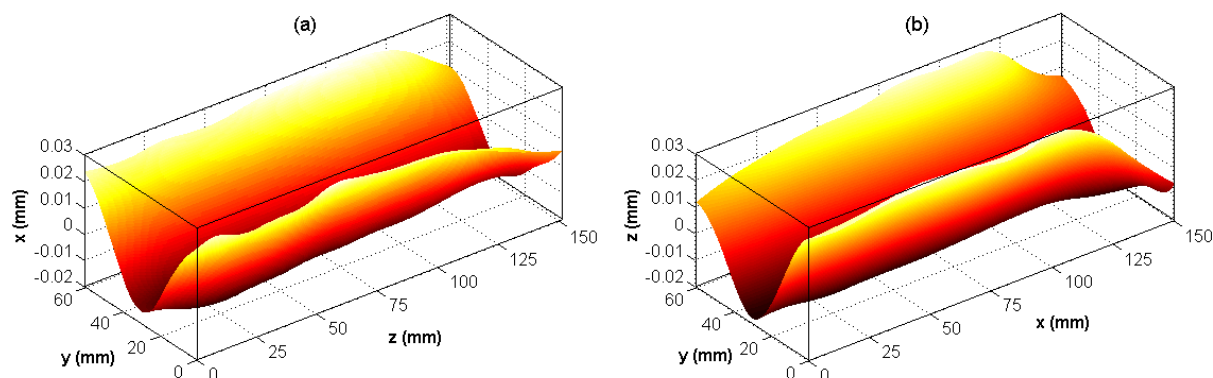

**Figure 6** Contour measured on the first cut surface (a) after cutting test specimen in two and on the second cut surface (b) after cutting half test specimen in two.

The  $\sigma_x$  stresses that were originally present on the plane of the first cut were calculated numerically by elastically deforming the cut surface into the opposite shape of contour that was measured at the same surface [1]. This was accomplished using the ABAQUS commercial FE code [13] and a 3-D elastic finite element model (see Figure 7a). A model was constructed of the front half of the specimen shown in Figure 3 (the condition after it had been cut in two). The mesh used 211.680 linear hexahedral (8 node) elements. The material behavior was isotropic elastic with an elastic modulus of 197 GPa and a Poisson's ratio of 0.29. In order to smooth out noise in the measured surface data and to enable evaluation at arbitrary locations, the data were fitted to a bivariate smoothing spline. The bivariate smoothing spline fits to the measured contour data were evaluated at a grid corresponding to the FE nodes, averaged between the two cut surfaces deformed into the opposite of the measured contour.

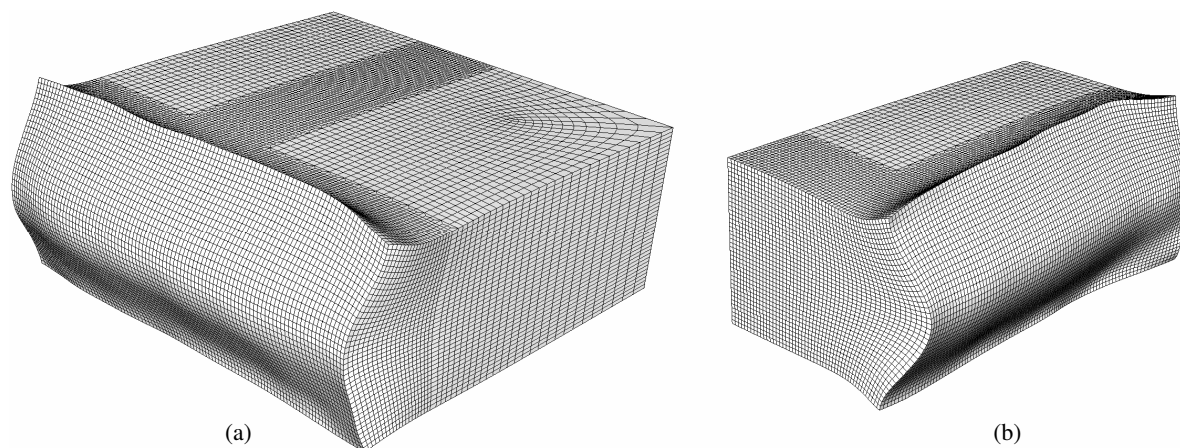

**Figure 7** FE model of HSLA-100 steel plate after the first cut (a) and after the second cut (b), deformed into opposite of measured shape in order to calculate original residual stresses. Deformation magnified by 400. This mesh correspond to the front half of the specimen in Figure 2.

As described before, the  $\sigma_z$  stresses that were present on the second cut plane after the execution of the first cut (step D in Figure 2) were calculated numerically by elastically deforming the cut surface into the opposite shape of contour that was measured on the same surface. This was accomplished using half of the previous 3-D FE model (see Figure 7b), by using the removing elements command in the second step of the previous FE analysis. The same fitting method was used to smooth the measured surface. This time was more noise in the data because of the probe used [12].

In order to obtain the original  $\sigma_z$  stresses present on the second cut plane (step A in Figure 2) it was only needed to sum the change of the  $\sigma_z$  stresses obtained after the first step of the FE analysis (step C in Figure 2) to the  $\sigma_z$  stresses obtained by the second step of the same FE analysis (step E in Figure 2).



### 3. RESULTS

Figure 8 shows the  $\sigma_x$  residual stresses on the first cut plane from Figure 3 (step A=C in Figure 3). Typical quenching stresses, tension in the center balanced by compression at the top and bottom, are evident. Within about 20 mm of the lateral edges, the stresses are noticeably different from those in the central region. Those edge effects are consistent with stress relaxation when the test specimen was removed from a large quenched plate, as was demonstrated by a finite element simulation of the stress relaxation caused by removing the test specimen [14].

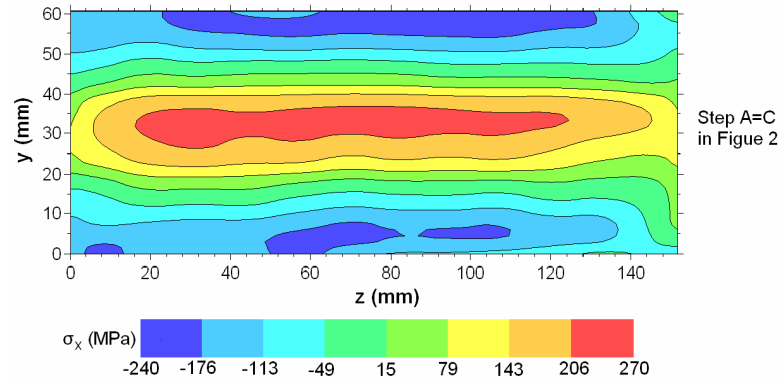

**Figure 8** Original  $\sigma_x$  residual stresses (Step A in Figure 2) in HSLA-100 specimen measured by the contour method on the first cut plane.

Figure 9 shows the stresses for the second cut and illustrates the reconstruction process. Figure 9a shows the  $\sigma_z$  residual stresses on the second cut plane from Figure 3 after the second step of FE analysis (step B=E in Figure 2). This stress map is very similar to the previous map (Figure 8), but in the left edge the effect of the first cut is evident (the right edge shows the effect or the original removal of the test specimen from a large quenched plate). Adding the stresses in Figure 9a to the change of  $\sigma_z$  obtained after the first step of the FE analysis, shown in Figure 9b (step C in Figure 2), the reconstructed original  $\sigma_z$  residual stress map is obtained on the second cut plane shown in Figure 9c (step A=B+C in Figure 2). Based on the left side of the results, it appears that the reconstruction has removed the effect of the first cut. By comparing the maps of  $\sigma_x$  in Figure 8 and of  $\sigma_z$  in Figure 9c, the approximately biaxial residual stress field typical of quenched plate is evident.

The reconstruction process is further illustrated by examining the stresses on the edge of the second cut where the stresses were most affected by the first cut. Figure 10 shows the through-thickness variation of  $\sigma_x$  for  $z=76.2$  mm in Figure 8 and of the  $\sigma_z$  stresses on the left edge of Figure 9, that correspond to common line of the two cut planes (line *a-b* in Figure 3). This figure shows that the contributions of the  $\sigma_z$  stresses calculated in step C and E to reconstruct the original  $\sigma_z$  stresses are approximately of the same size. Further, it is also evident that the profile of the original residual stress  $\sigma_x$  and  $\sigma_z$  are very similar, how it is expected for a quenched plate. The difference between these stresses is about less than 40 MPa along the through-thickness direction, except of the right edge ( $y=60.75$  mm) where the difference is about 80 MPa. Because this line is the edge of the second cut, contour method stresses are expected to be less accurate there because the assumption of a flat cut is not perfect on the edge. This explains some of the difference. Also, error accumulation from the two cuts would indicate that uncertainties should be larger for reconstructed stresses.

### 4. DISCUSSION

As presented, the multiple stress components contour method measures the stress components normal to multiple cut surfaces, which is fine for many measurement applications because the normal stresses are often the largest and the main contributors to failure.

The experimental results convincingly demonstrate the effectiveness of the simple process to reconstruct the original residual stresses on the plane of the second cut. The difference between the original  $\sigma_x$  and  $\sigma_z$  residual stresses in the region where the first cut affected the stresses for the second

but are very low after reconstruction, confirming the typical biaxial quenching stress. Some difference between the  $\sigma_x$  and  $\sigma_z$  residual stresses could be caused by different material properties along the x and z directions, in fact the yield stress is respectively 690 MPa and 685 MPa along the x and z direction.

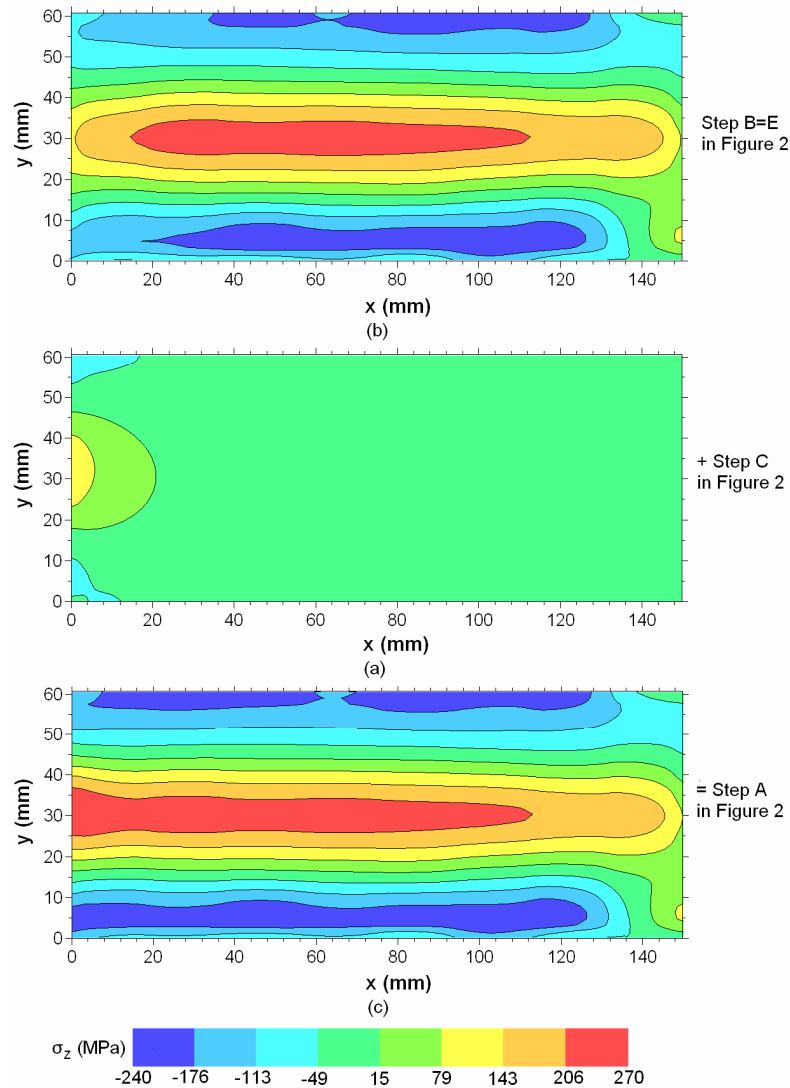

**Figure 9**  $\sigma_z$  after the second cut (a) (step B=E in Figure 2), change of  $\sigma_z$  after the first cut (b) (step C in Figure 2), and reconstructed original  $\sigma_z$  residual stresses (c) (step A=B+C in Figure 2) in HSLA-100 specimen measured by the multi-component contour method on the second cut plane.

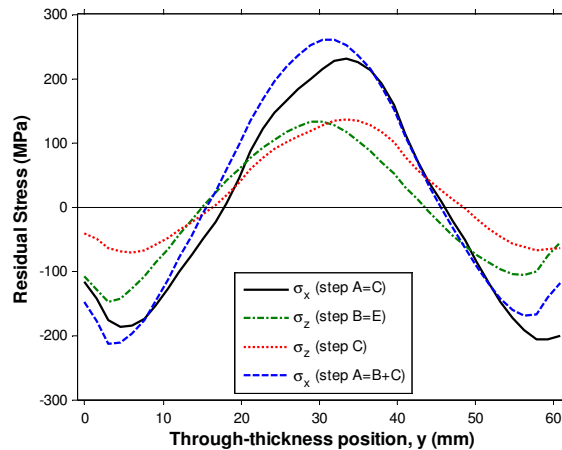

**Figure 10** Through-thickness variation along the line a-b in Figure 3 of  $\sigma_z$  and  $\sigma_x$  residual stresses in HSLA-100 specimen.

Some of the results would have been better if a better arrangement was used to clamp the part during the EDM cutting. In both Figure 8 and Figure 9, the right of the figure corresponds to the end of the EDM cut, which started on the left of each figure. The stress gradients at the right side of those figures are a result of the part moving during the end of the cut and changing the cutting path. These experiments were performed some time ago, and the clamping arrangement in Figure 4 is no longer used. In that figure, the clamping direction is the same as the cutting direction. Now, the clamping direction is the same direction as the wire axis, which is vertical in Figure 4. This has proven to provide better clamping and good data all the way to the end of the cut.

## 5. CONCLUSION

In the present paper the extension of the “contour method” to the analysis of the various normal residual stress components by multiple cuts of the examined part, is proposed. By taking into account properly the influence of the successive cuts, carried out by using EDM, the method permits the correct reconstruction of the initial normal residual stress distributions in all the cut planes. Experimental tests carried out on a plate of quenched High-Strength Low-Alloy steel, have revealed the typical approximately biaxial quenching residual stresses.

## ACKNOWLEDGEMENTS

This work was performed at Los Alamos National Laboratory, operated by the Los Alamos National Security, LLC for the National Nuclear Security Administration of the U.S. Department of Energy under contract DE-AC52-06NA25396. By acceptance of this article, the publisher recognizes that the U.S. Government retains a nonexclusive, royalty-free license to publish or reproduce the published form of this contribution, or to allow others to do so, for U.S. Government purposes. Ing. Pagliaro’s work was sponsored by a fellowship from the Università degli Studi di Palermo.

## REFERENCES

- [1] Prime, M.B., “Cross-Sectional Mapping of residual Stresses by Measuring the Surface Contour After a Cut,” *J. Engineering Materials and Technology*, 123, 162-168, 2001.
- [2] Prime, M.B., *U.S. Patent 6.470.756*, 2002.
- [3] Lu, J., James, M., and Roy, G., *Handbook of Measurement of residual Stresses*, The Fairmont Press, Inc., Lilburn, Georgia, USA, 1996.
- [4] Krawitz, A.D., and Winholtz, R.A., “Use of Position-Dependent Stress-Free Standards for Diffraction Stress Measurements,” *Mat. Sci. Eng., A*, 185, pp.0123-130, 1994.
- [5] Withers, P.J. and Bhadeshia, H.K.D.H., “Overview – Residual Stress Part I – Measurement Techniques,” *Materials Science and Technology*, 17 (4), 335-365, 2001.
- [6] Smith, D.J., Bouchard, P.J., and George, D., “Measurement and Prediction of Residual Stresses in Thick-section Steel Welds,” *Journal of Strain Analysis for Engineering Design*, 35 (4), 287-305, 2000.
- [7] Prime, M. B., Newborn, M. A., and Balog, J. A., “Quenching and Cold-Work Residual Stresses in Aluminum Hand Forgings: Contour Method Measurement and FEM Prediction,” *Materials Science Forum*, 426-432, pp. 435-440, 2003.
- [8] DeWald, A. T., and Hill, M. R., “Multi-Axial Contour Method for Mapping Residual Stresses in Continuously Processed Bodies,” *Experimental Mechanics*, 46(4), pp. 473-490, 2006.
- [9] Bueckner, H.F., “The Propagation of Cracks and the Energy of Elastic Deformation,” *Trans. ASME*, 80, pp1225-1230, 1958.
- [10] Timoshenko, S.P., and Goodier, J.N., 1970, *Theory of Elasticity*, 3<sup>rd</sup> Edition, McGraw-Hill, New York, Article 96, 1970.
- [11] Cheng, W., Finnie, I., Gremard, M., Prime, M.B., “Measurement of Near Surface Residual Stresses Using Electric Discharge Wire Machining,” *J. Engineering Materials and Technology*, 116 (1), 1-7, 1994.
- [12] Prime, M.B., Sebring, R.J., Edwards, J.M., Hughes, D.J., and Webster, P.J., “Laser Surface-contouring and Spline Data-smoothing for Residual Stress Measurement,” *Experimental Mechanics*, 44 (2), 176-184, 2004.
- [13] ABAQUS/Analysis User Manual Version 6.4, ABAQUS, Inc., 2003.
- [14] Prime, M. B., “Residual Stresses Measured in Quenched HSLA-100 Steel Plate,” *SEM Annual Conference and Exposition on Experimental and Applied Mechanics*, Portland, OR, USA, CD ROM paper 52, 2005.