



Advanced Space Exploration

# LSSCS BAA Topic 2: MFHE Final Review

**Dallas Bienhoff**  
**Contract Manager**  
**703-414-6139**  
**Dallas.g.bienhoff@boeing.com**  
**February 20, 2009**

# Boeing MFHE Final Review Agenda

 <b>Introductions</b>	<b>5</b>
● <b>MFHE Overview</b>	<b>25</b>
● <b>Functions and Subsystem Allocation</b>	<b>10</b>
● <b>Subsystems</b>	<b>40</b>
● <b>MFHE Variant Discussion</b>	<b>10</b>
● <b>Deployable and Growth Concepts</b>	<b>15</b>
● <b>Questions</b>	<b>15</b>

# Boeing Study Team Participants Included: Academia, Entrepreneurs, and 2<sup>nd</sup> Tier Suppliers

- Andrew Daga & Associates
- American Aerospace Advisors
- Hamilton Sundstrand
- Harris
- Honeywell
- ILC Dover
- Lunar Transportation Systems
- Oceaneering
- Orion Propulsion
- SICSA
- Thin Red Line
- USA



# Boeing MFHE Final Review Agenda

● Introductions	5
 MFHE Overview	25
● Functions and Subsystem Allocation	10
● Subsystems	40
● MFHE Variant Discussion	10
● Deployable and Growth Concepts	15
● Questions	15

# LSSCA BAA Topic 2: MFHE Definition Final

## ● Minimum Functionality Habitation Element

- Definitions, Updates, and Assumptions
- Requirements
- Integrated Solutions
- Rationale
- Subsystems

## ● Deployable Habitat

- Additional Requirements
- Integrated Solutions
- Rationale
- Key Differences

## ● The Path to Growth

- Achieving Outpost Capability

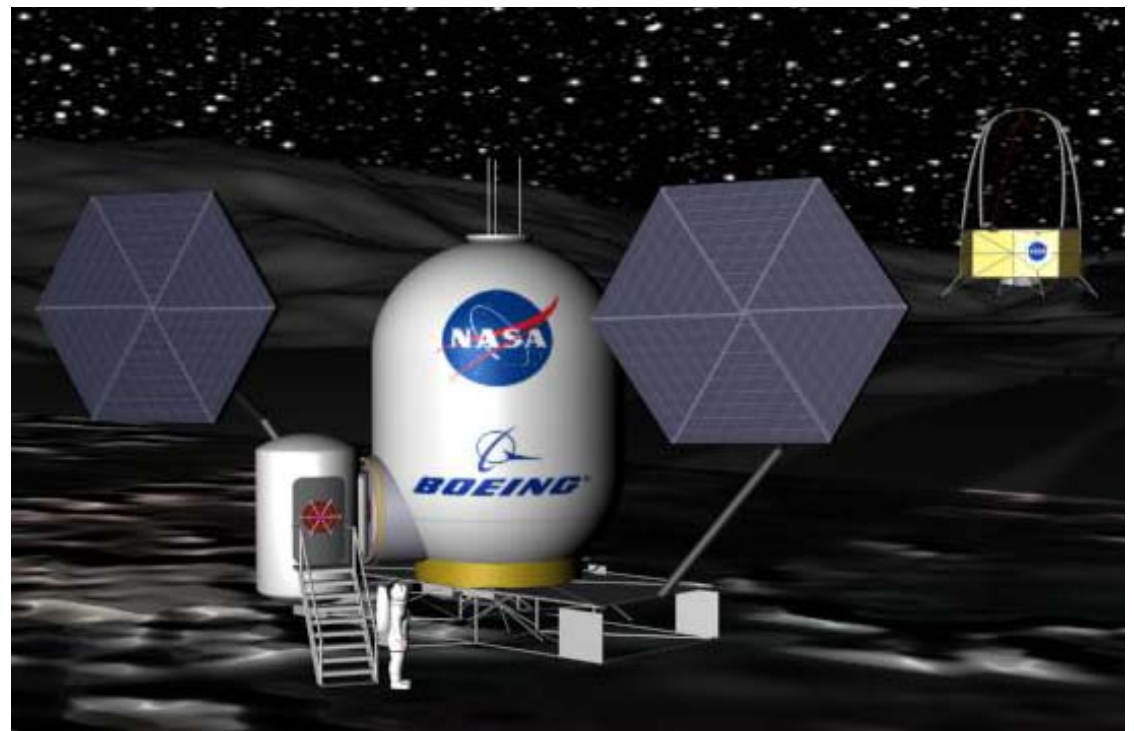

# Boeing Integrated MFHE Concept PILL - Pressurized Interim Lunar Lodge

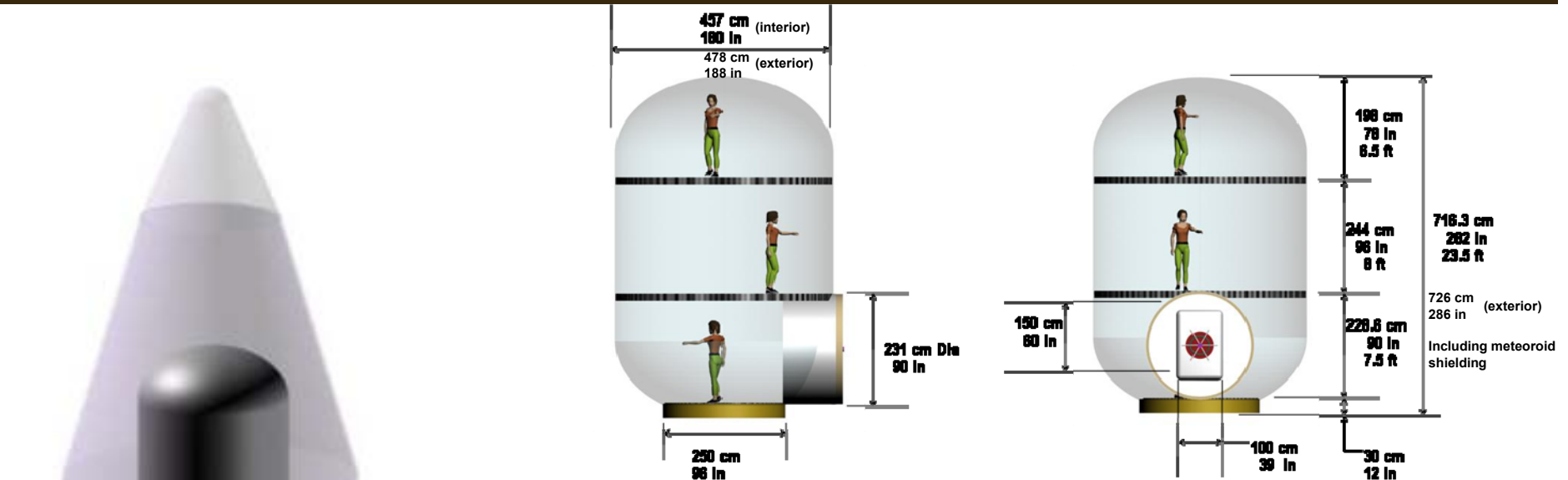

- Vertically oriented habitat
- One primary and two ancillary floors
- 457 cm (15 ft) diameter with 228.5 cm (7.5 ft) ceiling
- 121.4 m<sup>3</sup> total volume; 77.8 m<sup>3</sup> habitable volume (64%)
- Open floor Areas: Entry: 5.9 m<sup>2</sup>; Living 9 m<sup>2</sup>; Loft 13.5 m<sup>2</sup>
- Entry foyer on lowest floor; Sleeping on upper floor
- General living and working activities on middle floor

# MFHE Living Space Arrangements

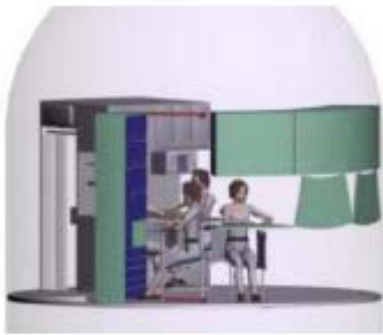

- **Four work stations**
  - Private medical and communications / Life Science
  - Mission and habitat operations
  - Physical sciences with glove box
  - Generic work desk
- **Food management and storage**
- **Hygiene module**
- **Toilet**
- **Dining / Conference table**
- **Access to lower & upper floors**

# Summary MFHE Characteristics (28 day Mission + 30 day Contingency)

Description	Qty	Mass (kg)	Int. Vol. (m3)	Ext. Vol. (m3)	Pk. Pwr (Watts)	Avg. Pwr (Watts)	Ht. Rej. (Watts)
Structure		3697	0.0000	0.0000	0	0	43
Avionics		79	0.0917	0.0000	263	263	
Communications		105	0.0330	0.0496	246	246	
Electrical Distribution		29	0.0000	0.0000	0	0	
ECLSS		138	0.4440	0.0116	748	368	
Thermal Control System		145	0.0000	0.0000	100	100	3036
Flight Crew Systems		69	2.3193	0.0000	315	315	
Work Stations		96	5.0758	0.0000	650	180	
28 Day Mission + 30 Day Contingency Logistics							
Logistics Pallet + Food		899	0.2787	2.2761	295	295	
Vented/Disposed (Info only; not in totals)		749	0.0000	0.0000	0	0	
28 Day Mission + 30 Day Contingency		5257	8.2425	2.3373	2617	1767	3079
Growth Allowance		499	3.4431	0.0000	1309	884	1518
Flight Support Equipment (5%)		288					
<b>Total</b>		<b>6044</b>	<b>11.686</b>	<b>2.337</b>	<b>3926</b>	<b>2651</b>	<b>4597</b>

- Internal volume for subsystem components
  - Required, with 25% packing factor 0.8 m<sup>3</sup>
  - Available in lower dome 17.1 m<sup>3</sup>
- Internal area for subsystem components
  - Required, with 25% packing factor 24.5 m<sup>2</sup>
  - Available in lower dome (1 layer on shell) 27.4 m<sup>2</sup>

Growth allowance: mass, structure - 15%; mass, components - 50%; power & heat rejection - 50%; packing factor - 25%



# Updates From 29 Jan 2009 MFHE TIM - 1

- **Switched to radical 2 dome from hemispherical**
  - Maintained overall length
  - Increased cylindrical length to provide more headroom in entry foyer
  - Included floor thickness to accommodate utility runs
  - Increased internal volume for same payload envelope footprint
- **Added Water Saver to ECLSS with SAWD to become SAVD**
  - 20 kg mass impact (estimated worst case solution)
  - No power impact
  - 80% recovery of atmospheric water vapor typically lost with CO<sub>2</sub>
- **Added intermodule interface definition**
  - Interface mechanism based on ISS CBM
  - Hatch based on ISS hatch
  - Entry tunnel

# Updates From 29 Jan 2009 MFHE TIM - 2

- **Rerouted Condensing Heat Exchanger water to VCD**
  - Ensures same quality for all recovered water
  - Commercial VCD provides potable water at outlet
  - Increased water loss based on increase VCD throughput
- **Removed Composting Toilet from MFHE consideration**
  - Has no advantage when waste is disposed on lunar surface
  - More appropriate with biochemical ECLSS and garden concepts
  - Negligible impact on mass balance and logistics mass

# MFHE BAA Requirements

The minimum functionality habitation element includes **basic required safety features** but **does not protect for contingency situations**.

1. **Identifying and defining** the proposed minimum required **functions**
2. **Providing rationale** for the proposed minimum required functions
3. Providing a **conceptual design (topology, layout, sections, 3D)** that accommodates the minimum required functions
4. Providing **mass, power and volume estimates** of the concept
5. Providing **potential growth options utilizing the concept**

R24: “**The 30-day contingency** should be considered part of the minimum functionality.”

R38: “On the same page 24, it lists a **7000 kg maximum mass constraint**.”

R39: “The Government is currently using a **useable volume of 860 m<sup>3</sup>, or roughly 8.8 m dia and 17.2 m tall**. The Government has **not identified a maximum power requirement** at this time.”

# LSSCS Industry Day MFHE Requirements

- 4-person crew for 28 days plus 30-day contingency
- 8 psi habitat pressure
- 30% oxygen concentration
- Verify “initial safe operational mode”
  - Post lunar descent
  - Prior to first crew Earth departure
- Provide health status prior to any crew Earth departure
- 7000 kg mass constraint
- Provide
  - Human waste management
  - Trash management (includes food waste)
  - Surface EVA support
  - Life support
    - Air revitalization
    - Thermal control
    - Humidity control
    - Pressurization

# MFHE Reference Mission Requirements and Assumptions

## Requirements

- Regular EVA excursions
- 7-28 day missions with 30-day contingency

## Assumptions

- Storage volume for 1200 kg (92 CTBs) consumables
- 5% tare for flight support equipment
- Water wall (to be filled by 90-day mission)
- Logistics & Support
  - Crewed periods
    - 270 kg/yr pressurized
    - 30 kg/yr unpressurized
  - Dormant periods
    - 30 kg/yr pressurized
    - 10 kg/yr unpressurized

# Boeing MFHE Final Review Agenda

● Introductions	5
● MFHE Overview	25
▶ Functions and Subsystem Allocation	10
● Subsystems	40
● MFHE Variant Discussion	10
● Deployable and Growth Concepts	15
● Questions	15

# Minimum Functions Allocated to Hab Element

- **Atmosphere Management (11)**
- **Communications**
- **Crew Accommodations (2)**
- **Data Management / C&DH (2)**
- **Dust Mitigation**
- **Electrical Power Distribution**
- **Food Management**
- **Hab Health Monitoring**
- **Health Management – Orion-type medical kit**
- **Hygiene Management**
- **Intermodule Connectivity (includes pressure equalization, entry hatch)**
- **Meteoroid Protection**
- **Radiation Protection**
- **Stowage**
- **Thermal Management (2)**
- **Waste Management (2)**
- **Water Management (2)**
- **Work Accommodations (2) (with C&C, D&C and C&W for mission ops)**

# Sub-Function Break Out

## ● Atmosphere Management

- Control – CO & combustible gas
- Control – O2 partial pressure
- Control – total pressure
- Control – temperature
- Control – humidity/condensation
- Containment – pressure
- Circulation; Ventilation
- Remove – CO2
- Remove – trace contaminants
- Remove – airborne particulates
- Remove – airborne microbes

## ● Crew Accommodations

- Sleep
- Lighting

## ● Data Management / C&DH

- Video and still imagery
- Data storage and processing

## ● Thermal Management

- Launch to activation
- Post activation

## ● Waste Management

- Biological; food
- Trash

## ● Water Management

- Potable
- Waste

## ● Work Stations (Accommodation)

- Mission Ops/Mission Control
- Physical & Life Sciences



# Minimum Functions Allocated to Other Surface Systems

- **Electrical Power (generation, management & storage)**
  - Power & Support Unit

*Power can be generated off line and transmitted to Hab*

- **EVA Support**
  - Airlock

*Must support EVA on sortie missions  
Includes pump only; no EVA or life support subsystems (per Altair study)*

- **Housekeeping/Maintenance**
  - Crew
  - Items not otherwise identified

*Don't force robotics for simple tasks*

- **Relocatability**
  - Power & Support Unit
  - Crew Mobility Chassis
  - Lunar Surface Manipulator

*Use separate mobility systems*

- **Structural Leveling**
  - Power & Support Unit

*Use PSU leveling system*

# MFHE Functions to Subsystem Allocation - 1

## ● Avionics

- C&DH
- Communications
- Hab Health Management
- Mission Operations Equipment

## ● Dust Mitigation

- Dust Mitigation

## ● ECLSS

- Air circulation
- Control CO
- Control combustible gases
- Control humidity
- Control O2 partial pressure
- Control temperature
- Control total pressure
- Human waste
- Potable water
- Remove airborne microbes
- Remove airborne particulates
- Remove CO2
- Remove trace contaminants
- Waste water

# MFHE Functions to Subsystem Allocation - 2

## ● Flight Crew Systems

- Food Management
- Health Management
- Hygiene Management
- Lighting
- Sleep Accommodations

## ● Mission Payloads

- Life Sciences
- Physical Science

## ● PMAD

- Distribution

## ● Structure & Mechanisms

- Contain Atmosphere
- Intermodule Connectivity
- Meteoroid Protection
- Radiation Protection
- Stowage

## ● Thermal Control System

- Activation forward
- Launch to Activation

## ● Trash Management

- Food & Biological
- Dry Trash

# MFHE Size Driving Requirements

- **Predictive to analog approaches**

- 10 - 75 m<sup>3</sup> per person

- **Ares V payload envelope**

- **Free volume per crew member (m<sup>3</sup>)**

- **Low** **37**
  - 50th percentile + 3σ American male horizontal reach diameter
  - 50th percentile + 3σ American male vertical reach
- **High** **max achievable**
  - Ares V payload shroud constraint
  - Maximum mass constraint

- **Linear wall space (m)**

- Food prep/hygiene 0.61
- Commode 0.56
- Health/Life Sci work area 0.91
- Mission ops work area 0.91
- Physical sci work area 0.91
- Desk/Computer work area 0.91
- Interconnect 0.60

- **Floor space - unique (m<sup>2</sup>)**

- Food prep/hygiene 0.54
- Commode 0.48
- Mission ops work area 0.54
- Physical sci work area 0.54
- Desk/Computer work area 0.54
- Health/Life Sci work area 0.54

- **Floor space - may overlay open**

- Sleep area 4.00
- Eating/meeting area 1.00

- **Internal storage (m<sup>3</sup>)**

- Food **dry - wet**
  - 14-d **0.07 - 0.15**
  - 28-d **0.13 - 0.30**
  - 28-d + 30-d cont. **0.28 - 0.63**
- Cleaning supplies\* 0.3
- Hygiene supplies\* 0.3
- Personal items (0.3/person)\* 1.2

\*Allocation

# Minimum Hab Size by Guidelines and Analogs\*

\* Rudisill, Howard, Kennedy, Stroud, "Lunar Outpost Habitat Volume Estimation," 5/20-21/2008

- **NASA TM-2003-210785 suggests 17 m<sup>3</sup>/person Total Volume**
- **Net Habitable or Usable Volume should be 60-66% of Total Volume**
- **Celantano, Amorelli, & Freeman Habitability Index**
  - Tolerable: 5 m<sup>3</sup>
  - Performance Limit: 10 m<sup>3</sup>
  - Optimal: 19 m<sup>3</sup>
- **Davenport, Congdon, & Pierce suggested 22.5-23.5 m<sup>3</sup> for 150-200 day missions**
- **Nuclear submarines provide 10-21 m<sup>3</sup> HV per crew member**
- **USN Tektite provided 125 m<sup>3</sup> TPV for 4 people on 2-month mission**
- **Aquarius provided 74 m<sup>3</sup> TPV for 6 people**
- **NASA Lunar Hab Team TPV findings for 4-person 180-day lunar hab**
  - Method 1 (Predictive): 301 - 367 m<sup>3</sup> (2.3 - 2.8x theory to reality)
  - Method 2 (Deriving & Validating): 3.5 m D preferred over 3.0 D horizontal  
Conclusion not noted for vertical hab

# Boeing MFHE Final Review Agenda

- Introductions 5
- MFHE Overview 25
- Functions and Subsystem Allocation 10
- Subsystems 40
- MFHE Variant Discussion 10
- Deployable and Growth Concepts 15
- Questions 15

## ● Subsystems

- Avionics
  - Communications
  - Dust Mitigation
  - ECLSS
  - Thermal Control System
  - Flight Crew Systems
  - Mission Ops / Mission Payloads
  - Power Management
  - Structures & Mechanisms
  - Logistics and Trash Management

# HI LSS Study Elements with Level Allocation - MFHE Avionics within LSS Architecture Concept

## Level 3

- Production Mgmt
- Maintenance Mgmt
- Resource Mgmt

## Level 2

### Vehicle Control

- Sequencing
- Directing
- Coordinating
- Health Status

## Level 1

- High Rate Control
- Standard IO/ Power Control
- Standard Sensor/ Effectors

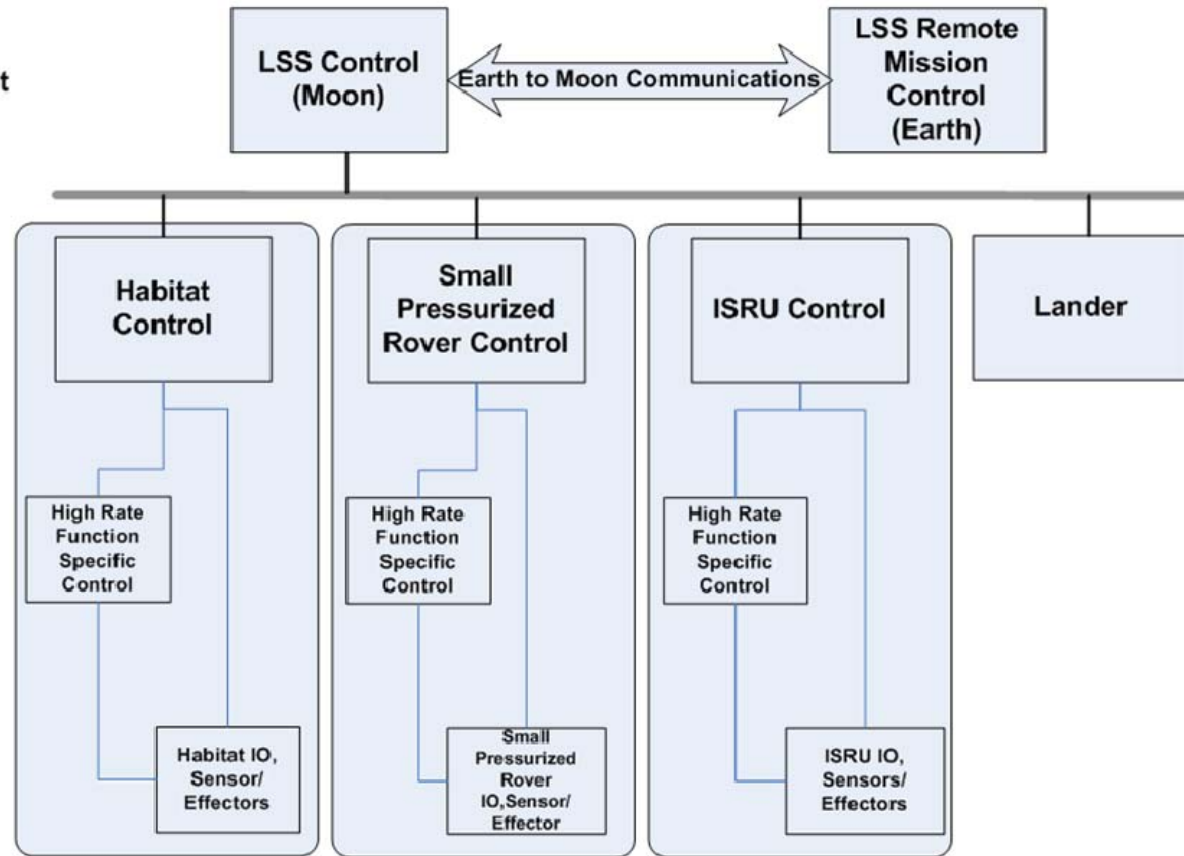

Enabled by standard functionality at each level with communications enabled by data standards

# HI LSS Study Function List by Level

## MFHE Functions Outlined

### Level 3 Functions

#### Automation Control Functions

- Production Mgmt
- Daily Instructions
- Procedure Automation
- Production Monitoring
- Boundary Management
- Electronic Shift Log
- Maintenance Mgmt
- Procedure Automation
- Resource Mgmt
- Asset Manager
- Alarm System Analysis & Awareness
- Video Manager

#### LSS Functions

- Crew Health Monitoring and Medical Systems
- External Environment Monitoring and Protection
- Mission Planning and Operations
- Prognostics, Maintenance and Logistics Management

### Level 2 Functions

#### Automation Control Functions

- Vehicle Control
- Sequencing
- Directing
- Coordinating
- Health Status
- Process Control & Monitoring

#### LSS Functions

- Command and Data Handling
- Communications & Tracking
- Crew Health Monitoring and Medical Systems
- Environmental Control and Life Support
- External Environment Monitoring and Protection
- Guidance Navigation and Control
- Remote and Autonomous Operation
- Surface Navigation
- Thermal Control
- Waste Management

### Level 1 Functions

#### Characteristics

- High Rate Closed Loop Control
- Standard IO/Power Control
- Standard Sensor/Effectors

#### LSS Functions

- Power
- Mobility
- Crew Interface
- Lighting (Part of ECLSS)



# Minimum Habitat Avionics Architecture

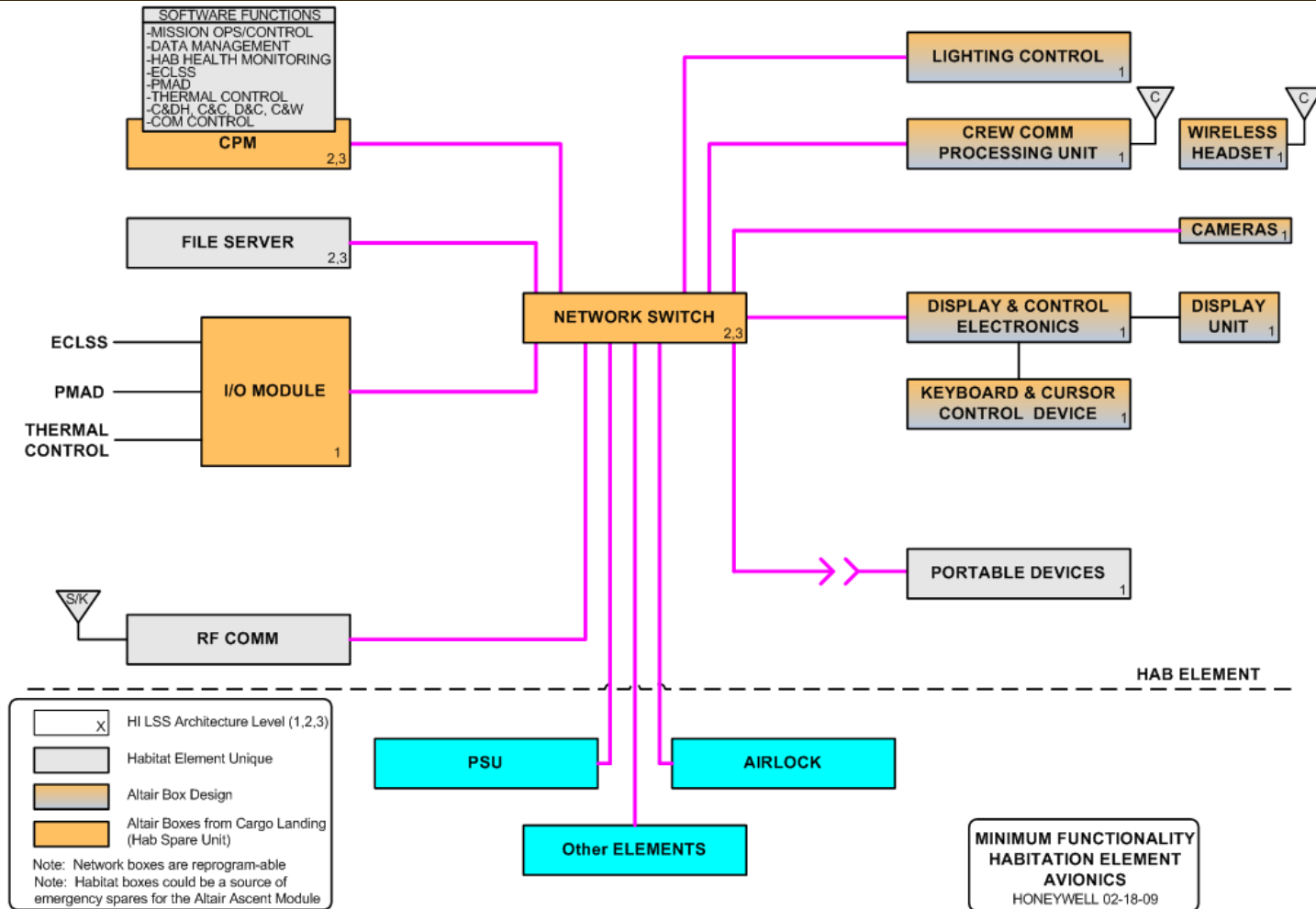

# Habitat Health Monitoring: Sensor List

## ● Atmosphere

- Total pressure
- Air temperature / control
- O<sub>2</sub> partial pressure
- CO<sub>2</sub> partial pressure
- O<sub>2</sub> addition capability
- N<sub>2</sub> addition capability
- CO<sub>2</sub> removal capability

## ● Consumables

- Stored O<sub>2</sub> mass
- Stored N<sub>2</sub> mass
- Stored water mass

## ● Fluid Controls

- Pump checks
- Motor checks
- Valve checks

## ● Power

- Bus voltage
- Energy storage level
- Production capacity

## ● Thermal

- Radiator outlet temperature
- Radiator inlet temperature
- Coolant pressure
- Coolant flow rate
- Accumulator quantity

• *All identified sensors are part of control function for identified capabilities; additional functionality to communicate hab health status to the ground.*

• *List provided in response to BAA requirement to support commit to launch decision.*

# Avionics Characteristics Detail

Description	Qty	Mass (kg)	Int. Vol. (m3)	Ext. Vol. (m3)	Pk. Pwr (Watts)	Avg. Pwr (Watts)	Ht. Rej. (Watts)
<b>Avionics</b>		<b>79</b>	<b>0.0917</b>	<b>0.0000</b>	<b>263</b>	<b>263</b>	
Common Processing Module	1	10	0.0130		50	50	
File Server	1	10	0.0130		50	50	
I/O Module	1	12	0.0156		20	20	
Network Switch	1	10	0.0130		28	28	
Lighting Control	1	3	0.0030		2	2	
Crew Common Processing Module	1	4	0.0040		8	8	
Crew Wireless Headsets	4	1	0.0026		0	0	
Displays & Controls Electronics	1	5	0.0065		20	20	
Display Unit	1	13	0.0170		80	80	
Keyboard	1	2	0.0020		3	3	
Cursor Control Device	1	2	0.0020		2	2	
Wiring, Fittings, and Secondary Structure (10% factor)		7					
Growth: H/W, Pwr, TCS (50%) / Int. Packing Factor (25%)		40	0.3668		132	132	

Growth allowance: mass, structure - 15%; mass, components - 50%; power & heat rejection - 50%; packing factor - 25%

# Boeing MFHE Final Review Agenda

- Introductions 5
- MFHE Overview 25
- Functions and Subsystem Allocation 10
- Subsystems 40
- MFHE Variant Discussion 10
- Deployable and Growth Concepts 15
- Questions 15

## ● Subsystems

- Avionics
- Communications
- Dust Mitigation
- ECLSS
- Thermal Control System
- Flight Crew Systems
- Mission Ops / Mission Payloads
- Power Management
- Structures & Mechanisms
- Logistics and Trash Management

# MFHE Communications Overview

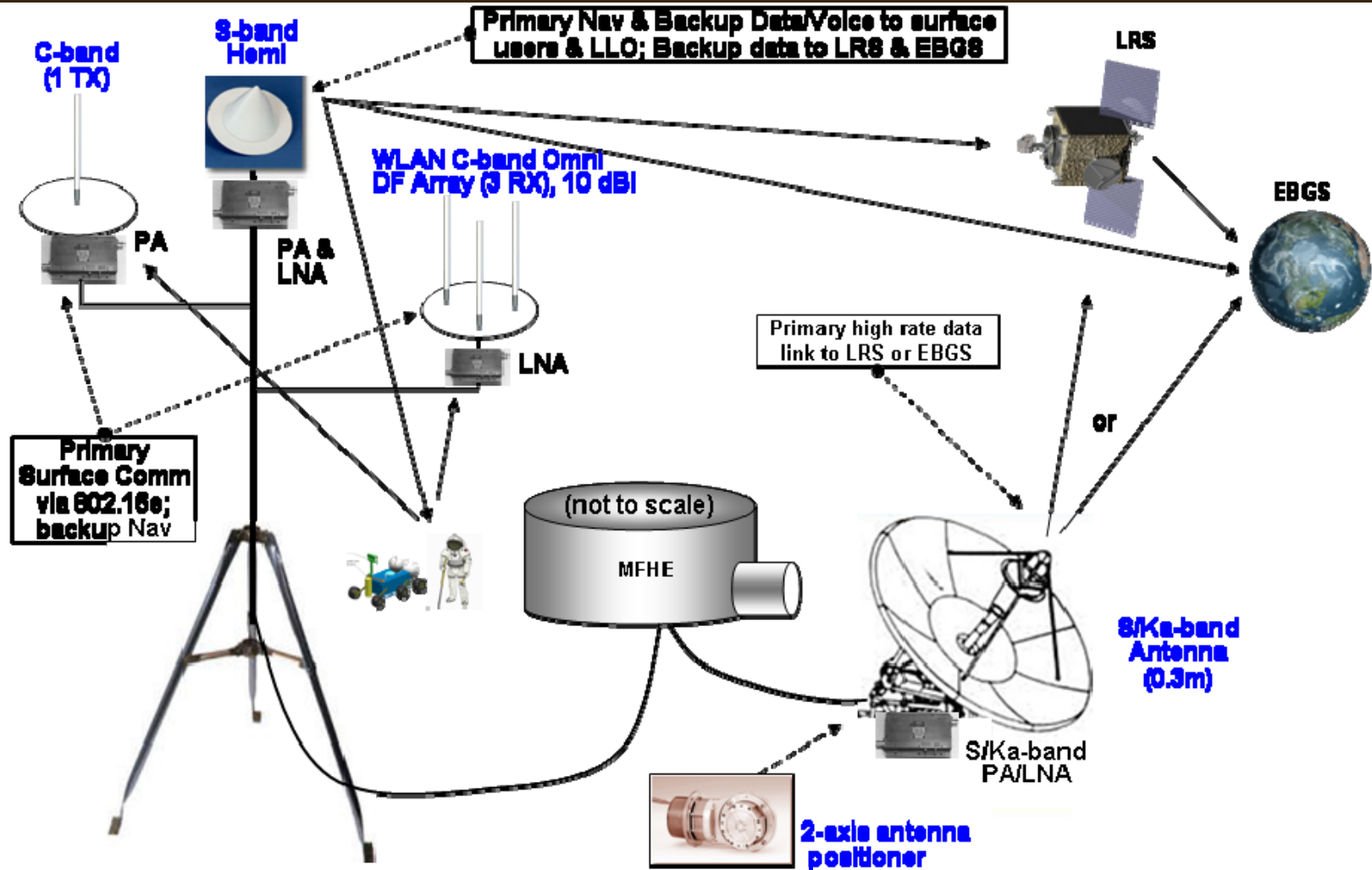

# Harris Fixed-Base Radio Design

- **Implemented using SDR (version III)**
- **Requires:**
  - One split C-band front end (converter, LNA and PA)
    - 5 watts RF out (TBR)
  - Four (1 TX, 3 RX) omni directional C-band antennas
  - One Ka-band front end
    - 5 watts
  - Two S-band front ends
    - 10 watts
  - One 0.3m Ka/S band dish
    - Gimbal
    - Controller
  - One atomic clock
  - Two SDRs
  - Two standalone S-band SDR-based SN radios for:
    - Communication to LRS and EBGs
    - Surface EVA communication and navigation
  - One internal router

# Habitat Internal Comm Requirements

## ● RFID passive tag system for inventory control

- Candidate standard: ISO/IEC 18000: Information technology:
  - Radio frequency identification used for item management:
- Frequency allocations:
  - < 135 kHz, 13.56 MHz, 433 MHz, 860-960 MHz, 2.45 GHz

## ● PAN

- Candidate standards: IrDA, Bluetooth, UWB, Z-wave, Zigbee
- Wireless peripherals
- Aggregating biometric data

## ● WLAN

- Candidate standard: 802.11x
- Provides connectivity of PC's, workstations, and telemetry data to habitat avionics hub/router
- May provide VoIP wireless headset capability

# Communications Characteristics Detail

Description	Qty	Mass (kg)	Int. Vol. (m3)	Ext. Vol. (m3)	Pk. Pwr (Watts)	Avg. Pwr (Watts)	Ht. Rej. (Watts)
<b>Communications</b>		<b>105</b>	<b>0.0330</b>	<b>0.0496</b>	<b>246</b>	<b>246</b>	
C-band PA (LAN)	1	0.7		0.0002	100	100	
Ka-band PA/LNA feed	1	0.7		0.0002	25	25	
S-band PAs/Duplexers	2	3.2		0.0004	50	50	
Gimbal, 2-axis	1	1.4		0.0008	10	10	
S-band Hemi antenna	1	0.3		0.0012		0	
C-band omni array elements	4	2.9		0.0010		0	
Ka/S-band dish	1	1.8		0.0141		0	
Antenna support pkg	1	8.2		0.0283		0	
Cables	10	63.0		0.0033		0	
Fixed Base Radio Chassis	1	4.9	0.0025		24	24	
Atomic Clock	1	0.4	0.0003		11	11	
S-band SN radios	2	3.3	0.0016		10	10	
Antenna controller	1	1.0	0.0006		4	4	
RFID	1	0.5	0.0006			0	
PAN	1	0.5	0.0006		1	1	
WLAN	1	2.4	0.0269		12	12	
Wiring, Fittings, and Secondary Structure (10% factor)		9.5					
Growth: H/W, Pwr, TCS (50%) / Int. Packing Factor (25%)		52	0.1319		123	123	

Growth Allowance: mass, structure - 15%; mass, components - 50%; power & heat rejection - 50%; packing factor - 25%



# Boeing MFHE Final Review Agenda

● Introductions	5	● Subsystems	
● MFHE Overview	25	• Avionics	
● Functions and		• Communications	
Subsystem Allocation	10	● Dust Mitigation	
● Subsystems	40	• ECLSS	
● MFHE Variant Discussion	10	• Thermal Control System	
● Deployable		• Flight Crew Systems	
and Growth Concepts	15	• Mission Ops / Mission Payloads	
● Questions	15	• Power Management	
		• Structures & Mechanisms	
		• Logistics and Trash Management	

# MFHE Dust Mitigation Characteristics Included in Other Subsystems

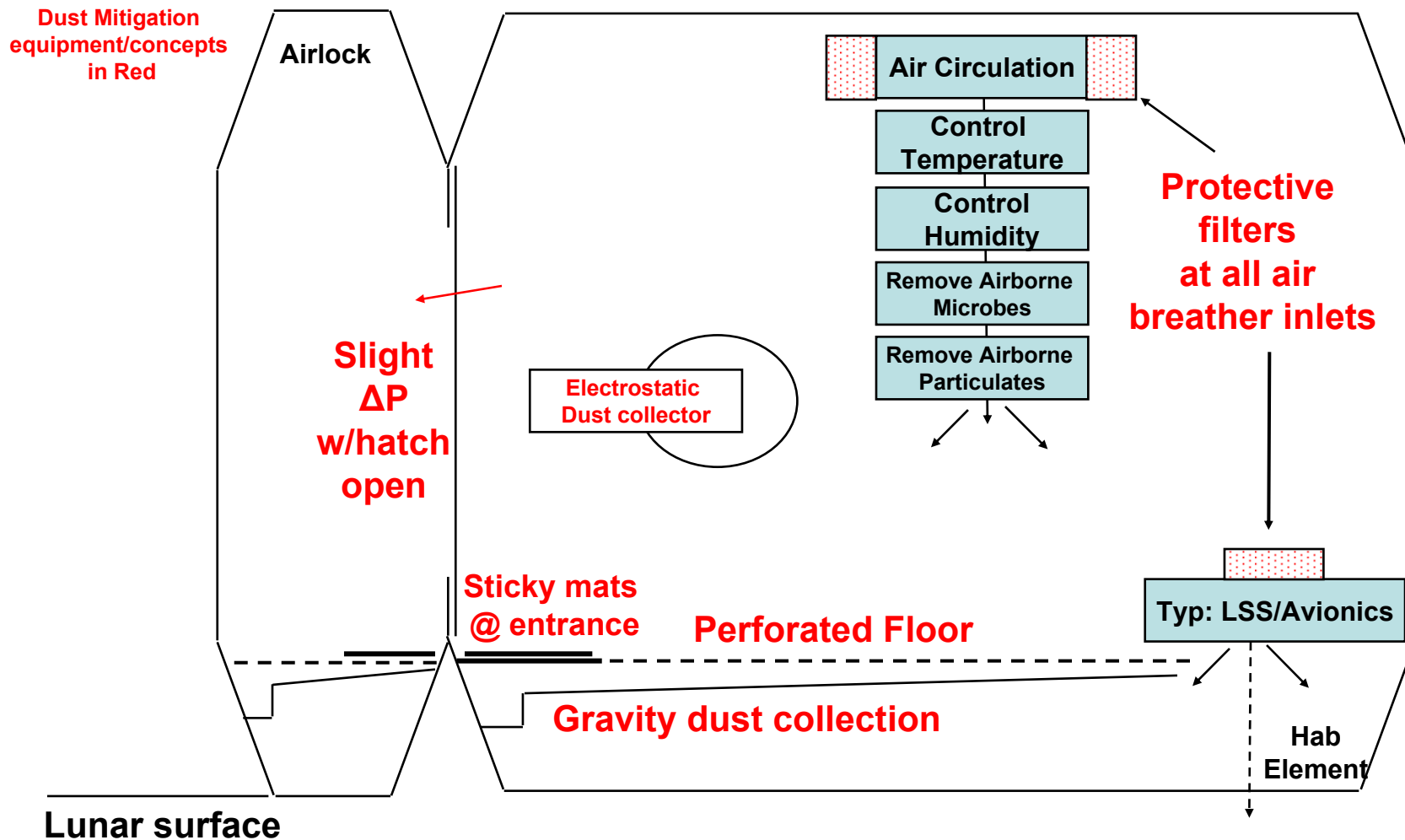

# Boeing MFHE Final Review Agenda

- Introductions 5
- MFHE Overview 25
- Functions and Subsystem Allocation 10
- Subsystems 40
- MFHE Variant Discussion 10
- Deployable and Growth Concepts 15
- Questions 15

## ● Subsystems

- Avionics
- Communications
- Dust Mitigation
- ECLSS
- Thermal Control System
- Flight Crew Systems
- Mission Ops / Mission Payloads
- Power Management
- Structures & Mechanisms
- Logistics and Trash Management



# MFHE ECLSS

- **Metabolic Model & EVA Support**
- **CO & combustible gases control**
- **Humidity control**
  - Condensing heat exchanger
  - Water Saver with CO<sub>2</sub> scrubber (SAVD)
- **O<sub>2</sub>/N<sub>2</sub> Sources**
- **Removal Processes**
  - CO<sub>2</sub>
  - Trace contaminants
  - Airborne microbes
  - Airborne particulates
- **Waste Management**
- **Water Management**
  - Potable water from waste water

# MFHE ECLSS Schematic (Trade Option 7a)

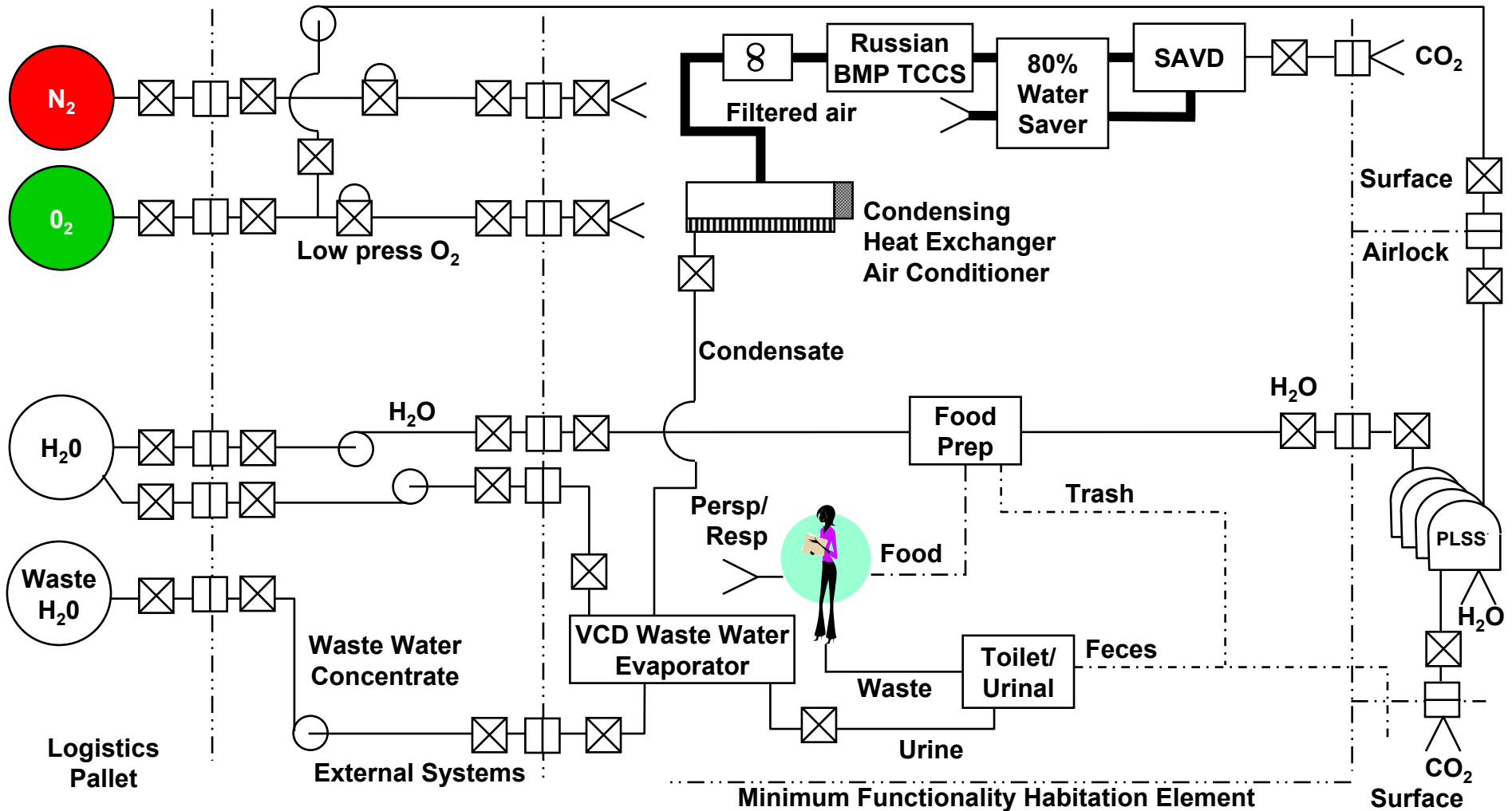

Feb 20, 2009

090220\_Boeing\_MFHE\_Final

36

# ECLSS Characteristics Details

Description	Qty	Mass (kg)	Int. Vol. (m3)	Ext. Vol. (m3)	Pk. Pwr (Watts)	Avg. Pwr (Watts)	Ht. Rej. (Watts)
<b>ECLSS</b>		<b>138</b>	<b>0.4440</b>	<b>0.0116</b>	<b>748</b>	<b>368</b>	
Condensing Heat Exchanger	1	10	0.2160				
Russian BMP TCCS	1		0.0283		300	30	
Solid Amine Vacuum Desorption	1	23	0.0100		120	10	
Vapor Compression Distillation Unit	1	45	0.0774		16	16	
Water Saver	1	20	0.0800		0	0	
Valves	28	20	0.0040	0.0072			
Pumps	5	5		0.0036	12	12	
Fan	1	2	0.0283		300	300	
Regulators	2	1		0.0008			
Wiring, Fittings, and Secondary Structure (10% factor)		13					
Growth: H/W, Pwr, TCS(50%) / Int. Packing Factor (25%)		69	1.7760		374	184	

Growth Allowance: mass, structure - 15%; mass, components - 50%; power & heat rejection - 50%; packing factor - 25%

# Boeing MFHE Final Review Agenda

- **Introductions** 5
- **MFHE Overview** 25
- **Functions and Subsystem Allocation** 10
- ▶ **Subsystems** 40
  - **MFHE Variant Discussion** 10
  - **Deployable and Growth Concepts** 15
  - **Questions** 15
- **Subsystems**
  - Avionics
  - Communications
  - Dust Mitigation
  - ECLSS
  - ▶ **Thermal Control System**
  - Flight Crew Systems
  - Mission Ops / Mission Payloads
  - Power Management
  - Structures & Mechanisms
  - Logistics and Trash Management

# Thermal Control System Heat Rejection Requirements

● <b>Maintain habitat temperature and humidity</b>	<b>158 W</b>
• 20° C and 30% humidity (10° C dew point)	
● <b>Maintain consumables supply temperature</b>	
● <b>Remove subsystem equipment heat with 50% growth</b>	<b>1117 W</b>
• ECLS:	478 W
• Flight Crew Systems (Lighting):	315 W
• Avionics	263 W
• Communications:	61 W
● <b>Remove crew heat (200 watts x 4 people) :</b>	<b>800 W</b>
● <b>Condition incoming oxygen and nitrogen</b>	<b>-7 W</b>
● <b>Offset MFHE structure heat loss: 0.394 W/m<sup>2</sup></b>	<b>-43 W</b>



# Single-Fluid Thermal Control Concept

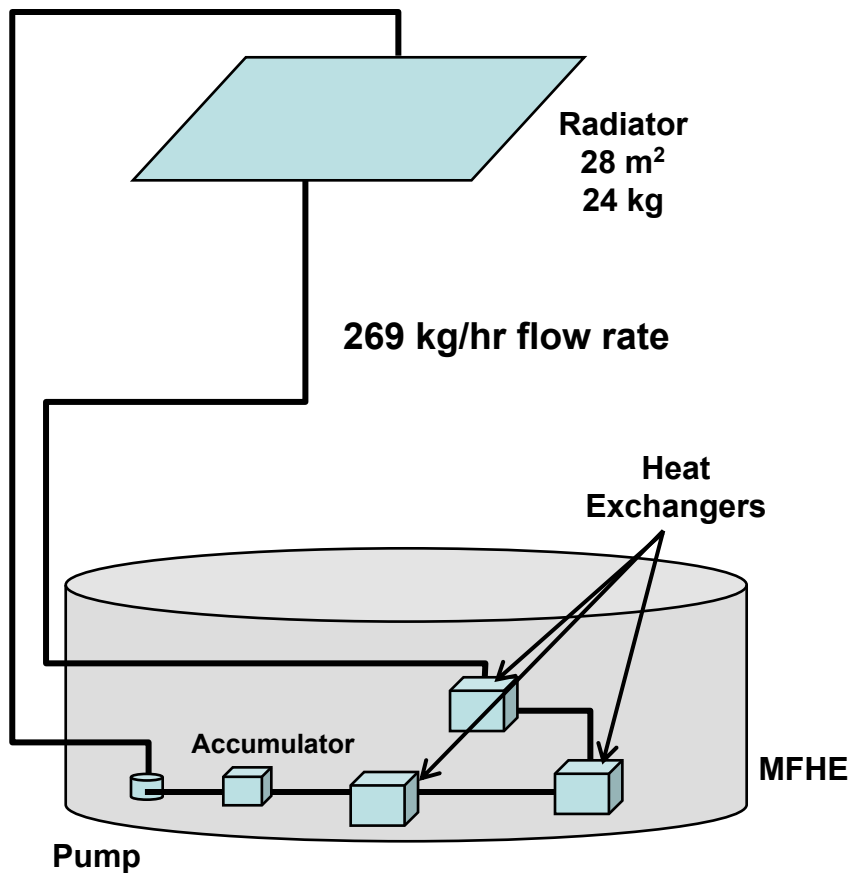

- Single-loop thermal control
- Simple flat-plate aluminum radiator
- 50% growth on heat rejection capability
- Assumed 20 gal coolant volume
- 3M Novec HFE-7200 coolant
  - Boiling point: 76 C
  - Pour point: -138 C
  - Density: 1420 kg/m<sup>3</sup>
  - Specific heat: 1220 J/kg-C
  - Heat of vaporization: 119 J/g
  - Coefficient of thermal expansion: 0.0016/C
- Heat exchangers and cold plates
  - Requires integrated systems analysis
  - Out of scope for MFHE study

# Thermal Control System Characteristics Detail

Description	Qty	Mass (kg)	Int. Vol. (m3)	Ext. Vol. (m3)	Pk. Pwr (Watts)	Avg. Pwr (Watts)	Ht. Rej. (Watts)
<b>Thermal Control System</b>		<b>145</b>	<b>0.0000</b>	<b>0.0000</b>	<b>100</b>	<b>100</b>	<b>3036</b>
Pump and Accumulator	1	3			100	100	
Coolant (gal)	20	108					
Radiator	1	24					3036
Valves	10	7					
Lines, Wiring, Fittings, and Secondary Structure (10% factor)		3					
Growth: H/W, Pwr, TCS (50%) / Int. Packing Factor (25%)		72	0.0000		50	50	1518

Growth allowance: mass, structure - 15%; mass, components - 50%; power & heat rejection - 50%; packing factor - 25%

# Boeing MFHE Final Review Agenda

● Introductions	5
● MFHE Overview	25
● Functions and Subsystem Allocation	10
▶ Subsystems	40
● MFHE Variant Discussion	10
● Deployable and Growth Concepts	15
● Questions	15

## ● Subsystems

- Avionics
- Communications
- Dust Mitigation
- ECLSS
- Thermal Control System
- ▶ Flight Crew Systems
- Mission Ops / Mission Payloads
- Power Management
- Structures & Mechanisms
- Logistics and Trash Management

# Flight Crew Systems: Food and Waste Management

- **Dehydrated food in 1-gallon bags**
  - 2.0 kg dry is equivalent to 10.0 kg wet
  - Metalized plastic bags
  - Five year shelf life
- **Personalized food trays, water bottle and utensils**
- **Hot or cold water to rehydrate**
- **Food bags reused for waste collection in dry toilet**
- **Waste drink collected in urinal for treatment**
- **Wet & dry solid waste collected in food & equipment bags**

# Flight Crew Systems: Food Prep, Hygiene, and Toilet Areas

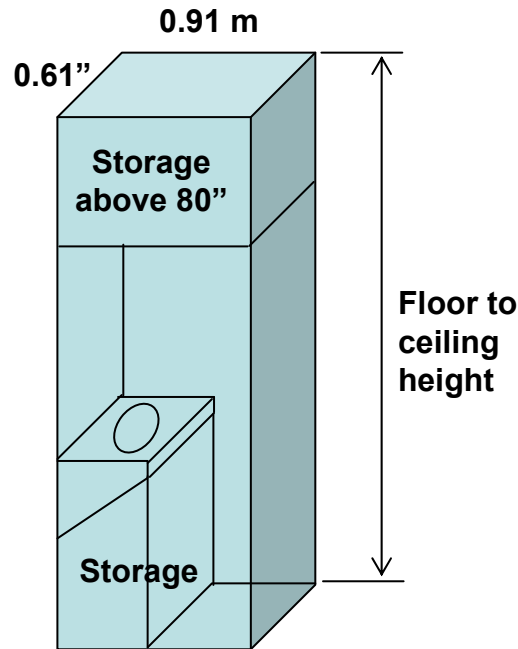

Food Prep / Hygiene

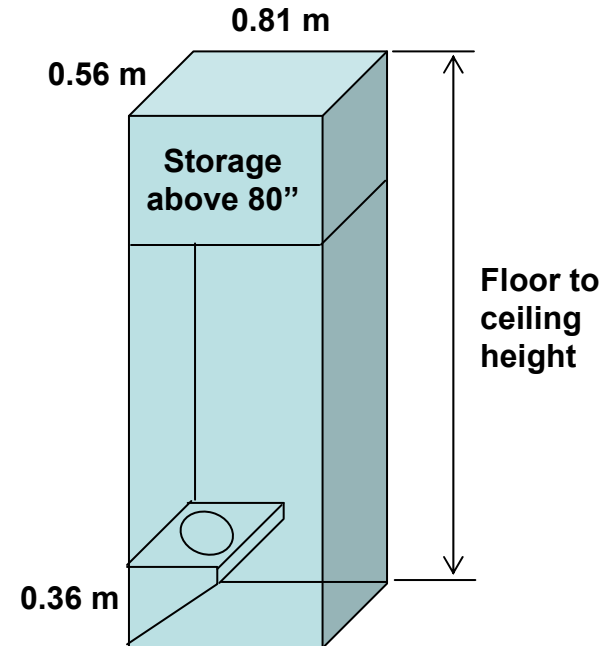

Toilet

Mass estimate assumption: Aluminum face sheet with paper honeycomb core panels at 3.4 kg/m<sup>2</sup> per Paneltec Corporation spec web site (<http://www.panelteccorp.com/html/stockpanels.html>); 0.5"x48"x96" @ 25.5 lbs.

# Flight Crew Systems Characteristics Detail

Description	Qty	Mass (kg)	Int. Vol. (m3)	Ext. Vol. (m3)	Pk. Pwr (Watts)	Avg. Pwr (Watts)	Ht. Rej. (Watts)
<b>Flight Crew Systems</b>		<b>69</b>	<b>2.3193</b>	<b>0.0000</b>	<b>315</b>	<b>315</b>	
Food Prep/Hygiene	1	30	1.2690				
Toilet	1	26	1.0369				
Sleep Accommodations	4	10					
Lighting	9	2	0.0134		315	315	
Exercise Equipment							
Growth: Str (15%); H/W, Pwr, TCS (50%); Int. Packing Factor (25%)		15	0.0536		158	158	

Growth allowance: mass, structure - 15%; mass, components - 50%; power & heat rejection - 50%; packing factor - 25%

# Boeing MFHE Final Review Agenda

- **Introductions** 5
- **MFHE Overview** 25
- **Functions and Subsystem Allocation** 10
- ▶ **Subsystems** 40
- **MFHE Variant Discussion** 10
- **Deployable and Growth Concepts** 15
- **Questions** 15
- **Subsystems**
  - Avionics
  - Communications
  - Dust Mitigation
  - ECLSS
  - Thermal Control System
  - Flight Crew Systems
  - ▶ **Mission Ops / Mission Payloads**
  - Power Management
  - Structures & Mechanisms
  - Logistics and Trash Management

# Mission Payloads: Work Spaces

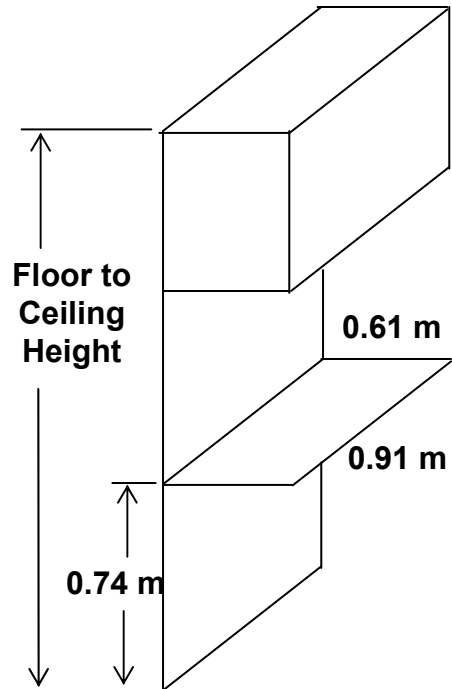

Storage above 1.37 m

**Life Sciences (& work desk)**  
**Mission Operations**  
**Health Management**  
**3 total**

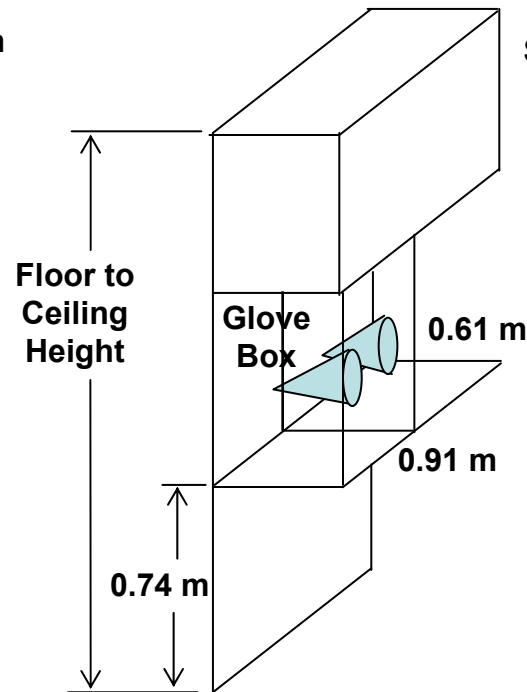

Storage above 1.37 m

**Physical Sciences**

Mass estimate assumption: Aluminum face sheet with paper honeycomb core panels at 3.4 kg/m<sup>2</sup> per Paneltec Corporation spec web site (<http://www.panelteccorp.com/html/stockpanels.html>); 0.5"x48"x96" @ 25.5 lbs.





# Mission Payloads Characteristics Detail

Description	Qty	Mass (kg)	Int. Vol. (m3)	Ext. Vol. (m3)	Pk. Pwr (Watts)	Avg. Pwr (Watts)	Ht. Rej. (Watts)
<b>Work Stations</b>		<b>96</b>	<b>5.0758</b>	<b>0.0000</b>	<b>650</b>	<b>180</b>	
Medical/Life Sciences	1	16	1.2690		100	20	
Physical Sciences	1	48	1.2690		150	80	
Command & Control	1	16	1.2690				
Work Desk/Computer	1	16	1.2690		400	80	
Growth: Str (15%); H/W, Pwr, TCS (50%); Int. Packing Factor (25%)	1	14			325	90	

Growth allowance: mass, structure - 15%; mass, components - 50%; power & heat rejection - 50%; packing factor - 25%

# Boeing MFHE Final Review Agenda

- Introductions 5
- MFHE Overview 25
- Functions and Subsystem Allocation 10
-  Subsystems 40
- MFHE Variant Discussion 10
- Deployable and Growth Concepts 15
- Questions 15
- Subsystems
  - Avionics
  - Communications
  - Dust Mitigation
  - ECLSS
  - Thermal Control System
  - Flight Crew Systems
  - Mission Ops / Mission Payloads
  -  Power Management
  - Structures & Mechanisms
  - Logistics and Trash Management

# PMAD: MFHE Power Distribution Concept

## Home Style - 28 V DC Altair Commonality

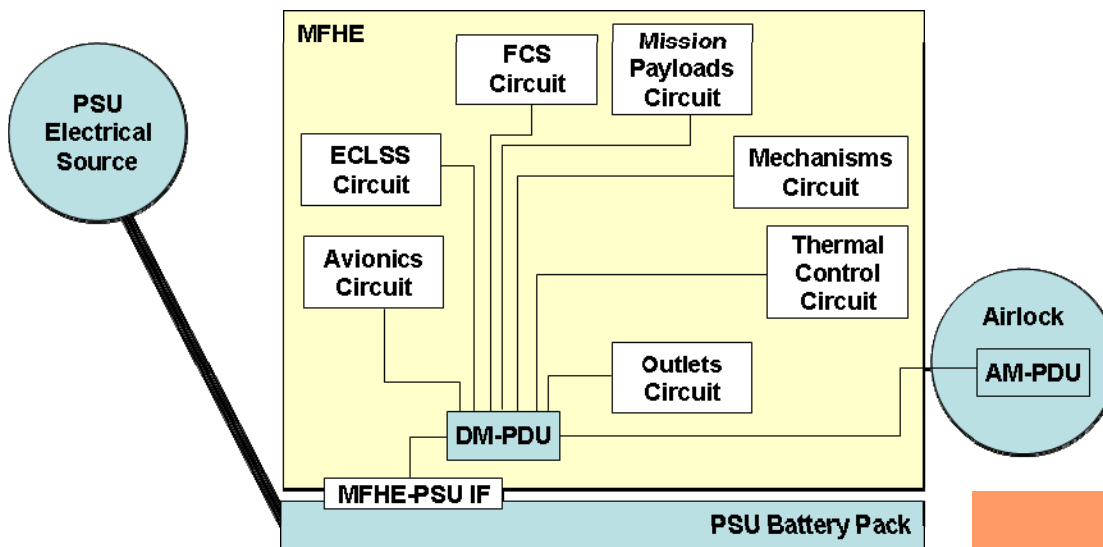

## Main Circuits

- Avionics & Communications
- Environmental Control & Life Support
- Flight Crew Systems
- Mission Payloads & Operations
- Mechanisms
- Thermal Control
- Utility outlets
- Airlock

### MFHE Basis

- Home Style derived from Altair components
- Minimal volume required for wiring;
- 8 main circuits @ 20 m length
- 3 AWG
- 3.65 kg/wire; 29.2 kg total

### Electrical Circuit Requirements



- 24.4 m max length from circuit breaker
- 48.8 m total length with return
- Maximum 1 volt drop at the end
- 20 amp maximum load
- Opportunity for mass savings
  - 4 AWG at 0.022 kg/m = 1.1 kg/wire; 8.8 kg total

# Electrical Distribution Characteristics Detail

Description	Qty	Mass (kg)	Int. Vol. (m3)	Ext. Vol. (m3)	Pk. Pwr (Watts)	Avg. Pwr (Watts)	Ht. Rej. (Watts)
<b>Electrical Distribution</b>		<b>29</b>	<b>0.0000</b>	<b>0.0000</b>	<b>0</b>	<b>0</b>	
Wiring	8	29					
Circuit Breaker Box							
Growth: H/W, Pwr, TCS (50%) / Int. Packing Factor (25%)		15					

Growth allowance: mass, structure - 15%; mass, components - 50%; power & heat rejection - 50%; packing factor - 25%

# Boeing MFHE Final Review Agenda

- **Introductions** 5
- **MFHE Overview** 25
- **Functions and Subsystem Allocation** 10
-  **Subsystems** 40
- **MFHE Variant Discussion** 10
- **Deployable and Growth Concepts** 15
- **Questions** 15
- **Subsystems**
  - Avionics
  - Communications
  - Dust Mitigation
  - ECLSS
  - Thermal Control System
  - Flight Crew Systems
  - Mission Ops / Mission Payloads
  - Power Management
  -  **Structures & Mechanisms**
  - Logistics and Trash Management

# Habitat Primary Structure

- **MFHE pressure vessel structural configuration**
  - Upright cylindrical pressure vessel with radical 2 domes
  - Aluminum construction
  - 0.48 cm (3/16") average thickness
    - 0.32 cm pressure vessel
    - 0.16 cm meteoroid shield 10 cm from pressure shell
  - 228.6 cm (7.5') hab cylinder internal radius
- **Ceiling to floor configuration**
  - 15.24 cm (6") spacing between ceiling and floor for utility runs
  - 0.48 cm (3/16") equivalent Al thickness for mass estimate
- **Perimeter walls (upper and lower volumes) and internal structure**
  - Aluminum honeycomb panels (Paneltec)
  - 3.4 kg/m<sup>2</sup>

# Intermodule Connector Assembly Concept

- **Horizontal intersecting cylinders for entryway / intermodule connector**
  - 0.5 m (19.7") x 228.6 cm (7.5') entryway diameter
  - 228.6 cm (7.5') cylinder assumed linearly scarfed from 0 - 228.6 cm
- **Hatch concept characteristics from ISS hatches**
  - ISS hatch ~ 54" on a side (1.88 m<sup>2</sup>)
  - MFHE hatch 1.0x1.5 m (1.5 m<sup>2</sup>)
- **Intermodule Connector**
  - Based on SPS 41004 max value for ACBM
  - Includes allowance for controllers and mechanisms



# MFHE Radiation Protection Approach: Single-Person Sleep Shelter

- Limit exposure to 25 cSv for 30 day mission for major SPE
- Normally stowed
- Shielding concept
  - 10 cm thick polyethylene pup tent and pad
  - Pressure vessel: No contribution
  - Floor/ceiling structure: No contribution
  - Interior outfitting: No contribution

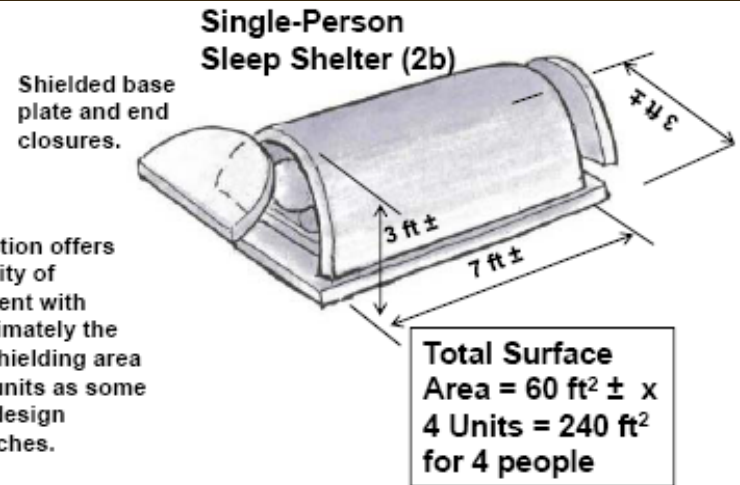

Radiation dose equivalent vs. regolith shielding thickness for the Oct 1989 GLE SPE

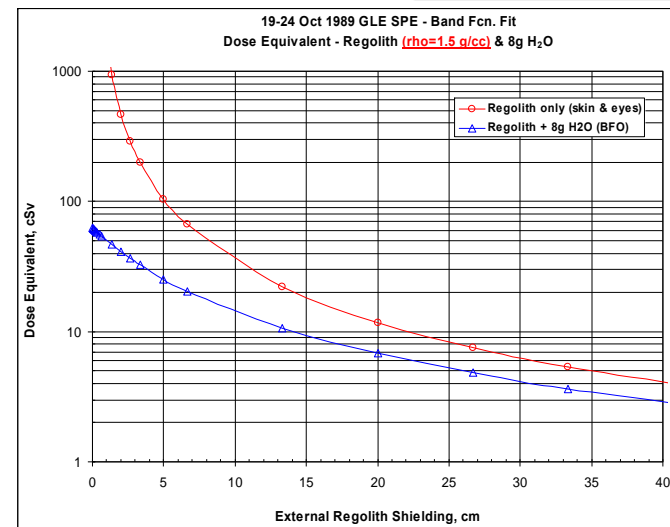



# Whipple Plate Meteoroid Protection Concept Provides 0.9997 1-Year PNP

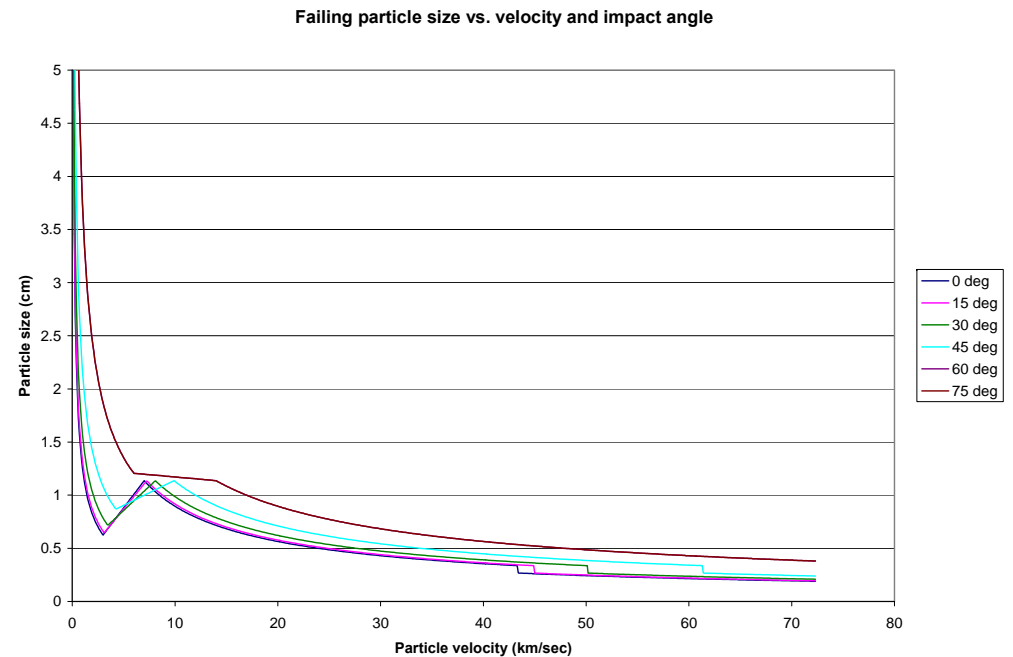
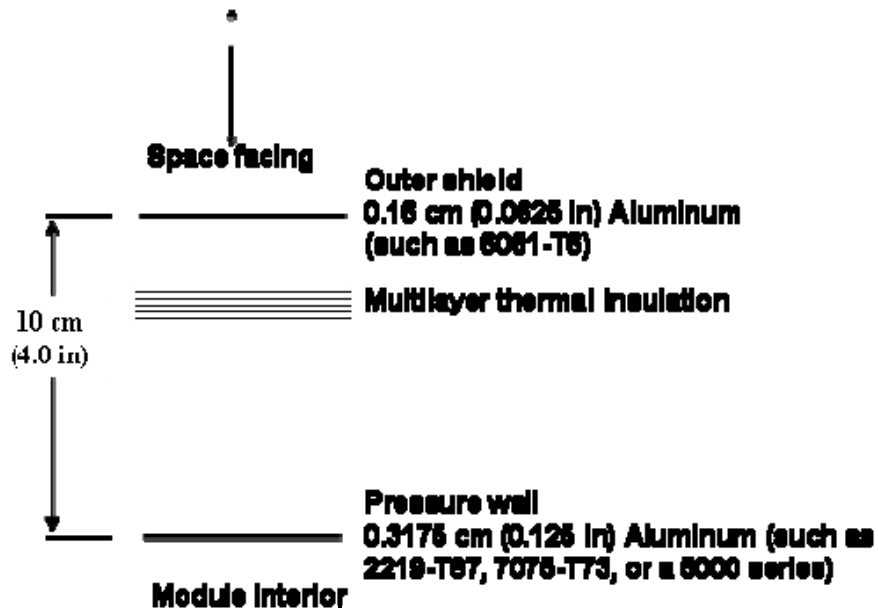

Probability of no penetration for MFHE for 1 year ~0.9997;  
Corresponds to one event in 3975 years.

# Structures Characteristics Detail

Description	Qty	Mass (kg)	Int. Vol. (m3)	Ext. Vol. (m3)	Pk. Pwr (Watts)	Avg. Pwr (Watts)	Ht. Rej. (Watts)
<b>Structure</b>		<b>3697</b>	<b>0.0000</b>	<b>0.0000</b>	<b>0</b>	<b>0</b>	<b>43</b>
Pressure Vessel & Meteoroid Shield	1	639					43
Floor	2	83					
Walls	1	112					
Ceiling	1	56					
Interface tunnel	1	84					
Hatch and mounting structure (ISS Hatch - no growth)	1	136					
Intermodule connector (ISS CBM - no growth)	1	272					
Atmosphere		86					
Radiation Protection (no growth)	4	2230					
Structure Growth (15% PV + 30% other)		146					

● **Growth allowance not applied to**

- Hatch
- Intermodule connector
- Atmosphere
- Radiation protection

Growth allowance: mass, structure - 15%; mass, components - 50%; power & heat rejection - 50%; packing factor - 25%

# Boeing MFHE Final Review Agenda

- Introductions 5
- MFHE Overview 25
- Functions and Subsystem Allocation 10
- ▶ Subsystems 40
- MFHE Variant Discussion 10
- Deployable and Growth Concepts 15
- Questions 15
- Subsystems
  - Avionics
  - Communications
  - Dust Mitigation
  - ECLSS
  - Thermal Control System
  - Flight Crew Systems
  - Mission Ops / Mission Payloads
  - Power Management
  - Structures & Mechanisms
  - ▶ Logistics and Trash Management

# MFHE Logistics Pallet Concept

- **Sized for 28-day Mission plus 30-day contingency**
- **New pallet required for each mission**
- **Requires interface to MFHE**
  - Couplings on lower dome
  - Couplings on pallet frame
  - Flex tube connectors
  - Hand holds and legs for positioning

- **Consumables Tanks**

• Oxygen tank (PRSD-type):	72 cm D	82 kg
• Nitrogen 2K psi tank:	42 cm D	4 kg
• Potable water (200 psi tank):	82 cm D	9 kg
• Waste water (200 psi max tank):	53 cm D	4 kg

- **Frame mass estimate**

- 1.25" x 0.12" steel tubing @ 1.448 lb/ft
- Truss structure; no top cross members
- 4.9 m of tubing
- 106 kg

- **Meteoroid shielding, thermal shielding, and secondary structure / wiring / connectors / flex hoses**

- 91 kg

- **Consumables**

• Oxygen:	196 kg
• Potable Water	262 kg
• Nitrogen	16 kg
• Waste Water (capacity 69 kg)	0 kg

- **Total Pallet Mass** **770 kg**

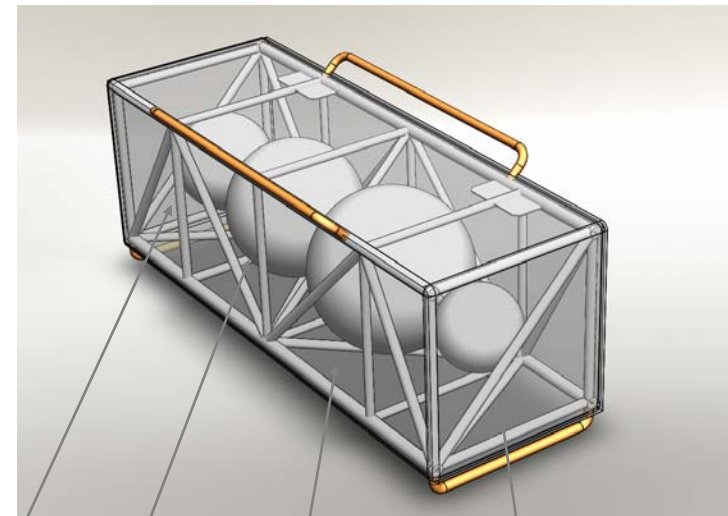

Waste Water      Oxygen      Potable Water      Nitrogen



# MFHE Trash Management Approach

- **Dry trash collected in typical kitchen trash bags**
- **Wet trash and feces collected in dry food bags**
- **Carried to lunar surface during egress for regularly scheduled EVA**
- **Placed in designated, protected area on lunar surface**
  - Inside logistics pallets?

# Logistics Pallet Characteristics

Description	Qty	Mass (kg)	Int. Vol. (m3)	Ext. Vol. (m3)	Pk. Pwr (Watts)	Avg. Pwr (Watts)	Ht. Rej. (Watts)
<b>28 Day Mission + 30 Day Contingency Logistics</b>							
<b>Logistics Pallet + Food</b>		<b>899</b>	<b>0.2787</b>	<b>2.2761</b>	<b>295</b>	<b>295</b>	
Structure		106		2.2761			
Thermal Blanket		12					
Meteoroid Protection		59					
Structure Growth (15% PV + 30% other)		16					
<b>Consumables</b>		<b>603</b>	<b>0.2787</b>	<b>0.0000</b>	<b>0</b>	<b>0</b>	
Nitrogen		16					
Oxygen		196					
Water, Fresh		262					
Food		126	0.2787				
Packaging, Food	1	3					
Tank, High Pressure, Nitrogen	1	4		0.0375	2	2	
Tank, PRSD, Oxygen	1	82		0.0967	289	289	
Tank, Water, Fresh	1	9		0.2238	2	2	
Tank, Water, Waste	1	4		0.3677	2	2	
Lines, Wiring, Fittings, and Secondary Structure (10% factor)		20					
Growth: H/W, Pwr, TCS (50%) / Int. Packing Factor (25%)		60	1.1149		148	148	

Growth allowance: mass, structure - 15%; mass, components - 50%; power & heat rejection - 50%; packing factor - 25%

# MFHE Concept Recap

- **Three floors in a 457 cm (15 ft) inner diameter vertical cylinder with radical 2 domes used for access and sleeping**
- **6044 kg total mass, including 499 kg growth allowance and 288 kg FSE**
- **3926 W peak electrical power, including 1309 W growth allowance**
- **2651 W average electrical power, including 884 W growth allowance**
- **4609 W heat rejection capability including 1522 W growth allowance**
- **121 m<sup>3</sup> total volume providing 78 m<sup>3</sup> habitable volume**
- **35 m<sup>2</sup> total floor space with 29 m<sup>2</sup> open floor space**

# Boeing MFHE Final Review Agenda

● Introductions	5
● MFHE Overview	25
● Functions and Subsystem Allocation	10
● Subsystems	40
● MFHE Variant Discussion	10
● Deployable and Growth Concepts	15
● Questions	15



# Six MFHE Variants Evaluated

## ● Three durations for evaluation

- 14-d (Scenario 4.0.0 duration with single hab element)
- 28-d (trade duration)
- **28-d plus 30-d contingency (MFHE BAA basis)**

*Does nominal mission duration lead to solution change?*

## ● Two habitation element volume perspectives during trades

- Minimum volume to meet mission requirements (**low**): 100 m<sup>3</sup>
- Maximum volume for Ares V payload shroud (**high**): 1500 m<sup>3</sup>
- Minimum surface area: 100 m<sup>2</sup>
- Maximum surface area: 808 m<sup>2</sup>

*Does larger module yield subsystem design benefits?*

## ● Nomenclature

- 14 **low**; 14 **high**
- 28 **low**; 28 **high**
- **28 + 30 low**; 28 + 30 **high**

# Impact to Logistics for Mission Duration

- 500 kg MFHE reduction possible

	L	M	G	T
28-d + 30-d C	899	5257	499	6044
28-d	627	4968	485	5744
14-d	388	4746	472	5479

- Logistics Pallet smaller by 22 x 73 cm

	W	D	L
28-d + 30-d C	90	90	281
28-d	83	83	247
14-d	68	68	208

Key:

- L - Logistics Pallet
- M - MFHE
- G - MFHE Growth Allowance
- T - Total

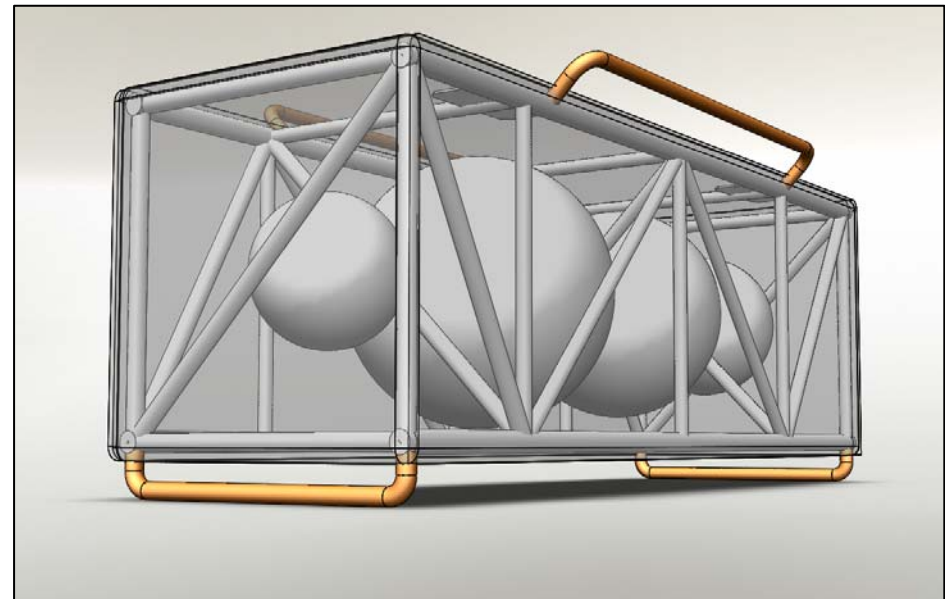

Note: Food is included in the Logistics mass

# MFHE Diameter Impact on Characteristics

	<u>457 cm D</u>	<u>880 cm D</u>
● Total Volume (m <sup>3</sup> )	124	395
● Habitable Volume (m <sup>3</sup> )	78	
● Total Floor Area	35 (6, 15, 14)	82 (61, 21)
● Usable Floor Area	29 (6, 9, 14)	75 (54, 20)
● Volume for Components (m <sup>3</sup> )	17	72
● Surface Area for Components (m <sup>2</sup> )	20	41
● Surface Area (m <sup>2</sup> )	110	262
● Habitat heat loss (W)	43	104
● Mass		
• Estimate	5257	7006
• Growth	499	727
• Flight Support Equipment	288	387
• Total	6044	8120

# Safety Improvements Proportional to Volume

## ● Tolerable hole size increases as square root of volume ratio

- 1.8 times increase for 1 hr to bends onset
  - 0.064 cm for 121.4 m<sup>3</sup>
  - 0.115 cm for 395.3 m<sup>3</sup>

## ● Response times increase as volume ratio

- 3.26 times longer to bends for 0.1 cm D hole
  - 1450 s for 121.4 m<sup>3</sup>
  - 4800 s for 395.3 m<sup>3</sup>
- 3.26 times longer to CO<sub>2</sub> limit if SAVD fails
  - 1.95 hr for 121.4 m<sup>3</sup>
  - 6.30 hr for 395.3 m<sup>3</sup>
- 3.26 times longer to 25% oxygen content
  - 29.4 hrs if O<sub>2</sub> not replenished for 121.4 m<sup>3</sup>
  - 97.8 hrs if O<sub>2</sub> if not replenished for 395.3 m<sup>3</sup>

Hole Size Providing One Hour to Bends Pressure

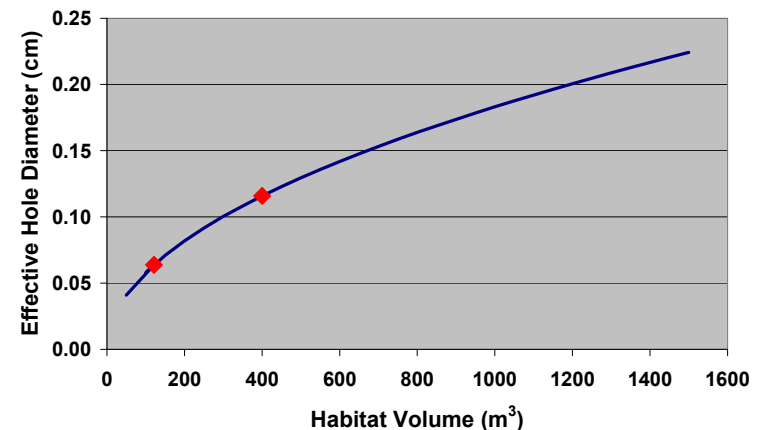

MFHE Pressure Decay for 0.1 cm D Hole

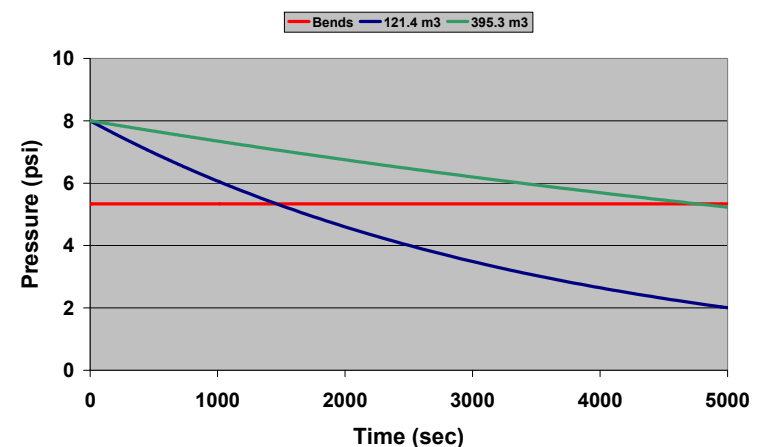

# Boeing MFHE Final Review Agenda

● Introductions	5
● MFHE Overview	25
● Functions and Subsystem Allocation	10
● Subsystems	40
● MFHE Variant Discussion	10
 Deployable and Growth Concepts	15
● Questions	15

# Deployable Habitat Concept

- **Deployable Hab derived from MFHE**
  - Base structure and content provides basis for Deployable
  - Specific subsystem upgrades
  - PMAD sized for Deployable and some Growth
- **Modifications to MFHE to make Deployable**
  - Added two access ports and hatches at surface
  - Added one hatch at top to accommodate inflatable concept
  - Added redundancy to Avionics, Communications, ECLSS, and TCS
  - Increased heat rejection capacity
  - Fire detection, suppression, and remediation
  - Exercise equipment
  - External viewing capability
  - Hab tool kit
  - Identified FDIR need (software, Avionics, etc.)
- **Inflatable module defined by not part of Deployable launch package**
- **Medical capability on deployed to be Orion kit**
  - Enhanced capability with Logistics Modules
- **Safety items**
  - Emergency breathing apparatus, hand held fire extinguisher, PPE

# Deployable Habitat Concept – Rationale (1)

Functions	Function Type					Modifications to MFHE to produce Deployable / Growth Hab	Affected subsystems										
	Mission Support	Survival/Survivability	Safety/Protection from Environment	Deployable Hab	Growth Habitat		Avionics	Communications	ECLSS	Thermal Control System	Flight Crew Systems	Mission Ops / Mission Payloads	Power Management	Structures & Mechanisms	Logistics	Trash Management	Software impacts (allocated to subsystem)
Additional habitable volume				X		Inflatable structure on top of MFHE; addition of top port and interface to MFHE; addition of logistics modules optional; outfitting for additional volume.	X	X	X	X	X	X	X	X	X	X	X
Atmosphere make-up due to penetration (coverage captured by 30-day contingency needs)				X		Repair capability; logistics for repressurization							X	X			
Atmosphere Management - carbon monoxide monitoring		X		X		Sensor addition; data handling	X		X								X
Atmosphere Management - minimal leak detection		X	X	X		Sensor addition; data handling	X		X				X				X
Exercise equipment				X		Exercise equipment, space to exercise, and equipment storage volume					X		X				
Fault Detection, Isolation and Recovery; Response to failures (loss of heaters, O2, CO2 removal, etc)				X		Sensor addition; data handling; redundant and spare equipment; volume for redundant and spare equipment	X	X	X	X		X	X	X			X
Fire Detection		X		X		Sensor addition; data handling; alarms; equipment controls; volume for equipment	X		X				X				X
Fire Remediation (smoke removal; post fire clean-up)				X		Clean-up equipment and supplies; ECLS design for consumables & control to purge cabin and refill; volume for storage of equipment; all equipment would have to deal with vacuum condition associated with cabin purge			X		X		X			X	
Fire Suppression		X		X		Fire suppression equipment; volume for equipment			X		X	X	X				X

# Deployable Habitat Concept – Rationale (2)

Functions	Function Type					Modifications to MFHE to produce Deployable / Growth Hab	Affected subsystems											
	Mission Support	Survival/Survivability	Safety/Protection from Environment	Deployable Hab	Growth Habitat		Avionics	Communications	ECLSS	Thermal Control System	Flight Crew Systems	Mission Ops / Mission Payloads	Power Management	Structures & Mechanisms	Logistics	Trash Management	Software impacts (allocated to subsystem)	
Image collection	X			X		Additional data storage; new cameras; external cameras; pan/zoom functionality for external cameras; additional image processing capability	X	X						X				X
Increased air filtration capability (smaller)				X		Additional or improved ECLSS equipment; equipment volume			X						X	X		
Outside viewing - crew health (window or view port)		X		X		Structural modifications for window or cameras / screens; wall space	X								X			
Overpressure protection				X		Overpressure valves; component design margins; structural margins	X		X					X				X
Vent from earth atmosphere (14.7 psi) to design (8.0) during ascent				X		Pressure relief to 8 psi hardware;	X		X			X	X					
Subsystem overcapacity wrt Deployable for anticipated Growth				X		Subsystem sizing based on anticipated greater capabilities; MFHE to Deployable already accommodates Growth options	X	X	X	X	X	X	X	X	X			
Suit storage and maintenance				X		Servicing equipment and workbench; final MFHE configuration has adequate volume for suit storage and maintenance.					X			X				
Unoccupied total and oxygen pp maintenance				X		Add six months of decay to logistics for 28 + 30 atmosphere consumables			X						X			



# Deployable Concept with Inflatable Upper Room

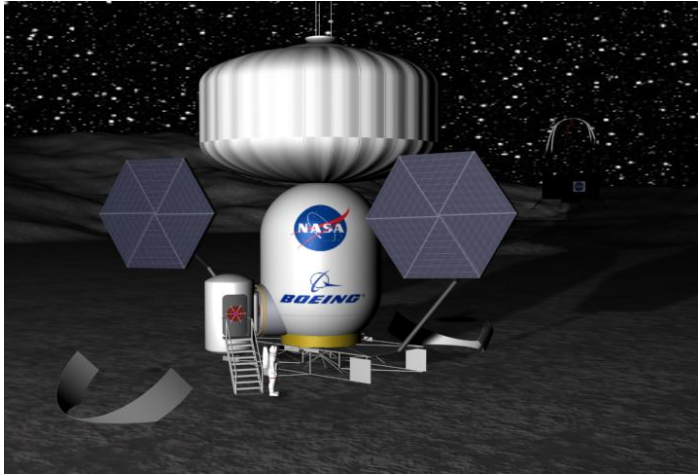

$CS = 0.26 \times D$   
(optimum volume to surface area  
- but not optimum mass)

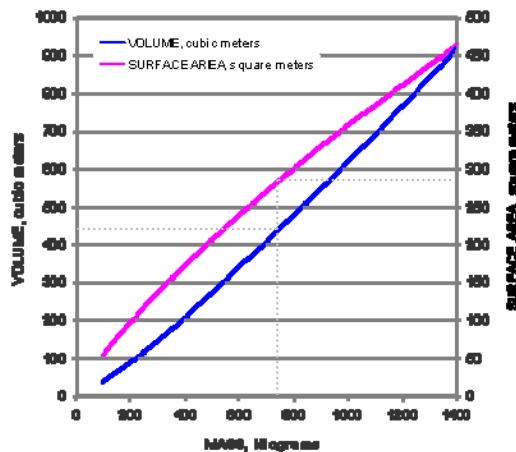

- Expandable volume deflated when delivered
- Additional atmosphere on logistics pallet
- Can be expanded during any crew mission
- Could be added on subsequent mission
- Could be inflated with gas on subsequent mission
- Characteristics of shown inflatable
  - Volume: 439 m<sup>3</sup>
  - Floor area: 120 m<sup>2</sup> total for 2 floors
  - Surface area: 290 m<sup>2</sup>
  - 312 kg of atmospheric gas
  - 700 kg of material
    - Includes trampoline flooring but no other outfitting
    - Does not include dedicated meteoroid protection
    - Does not include dedicated radiation protection

# Deployable Habitat Avionics Architecture

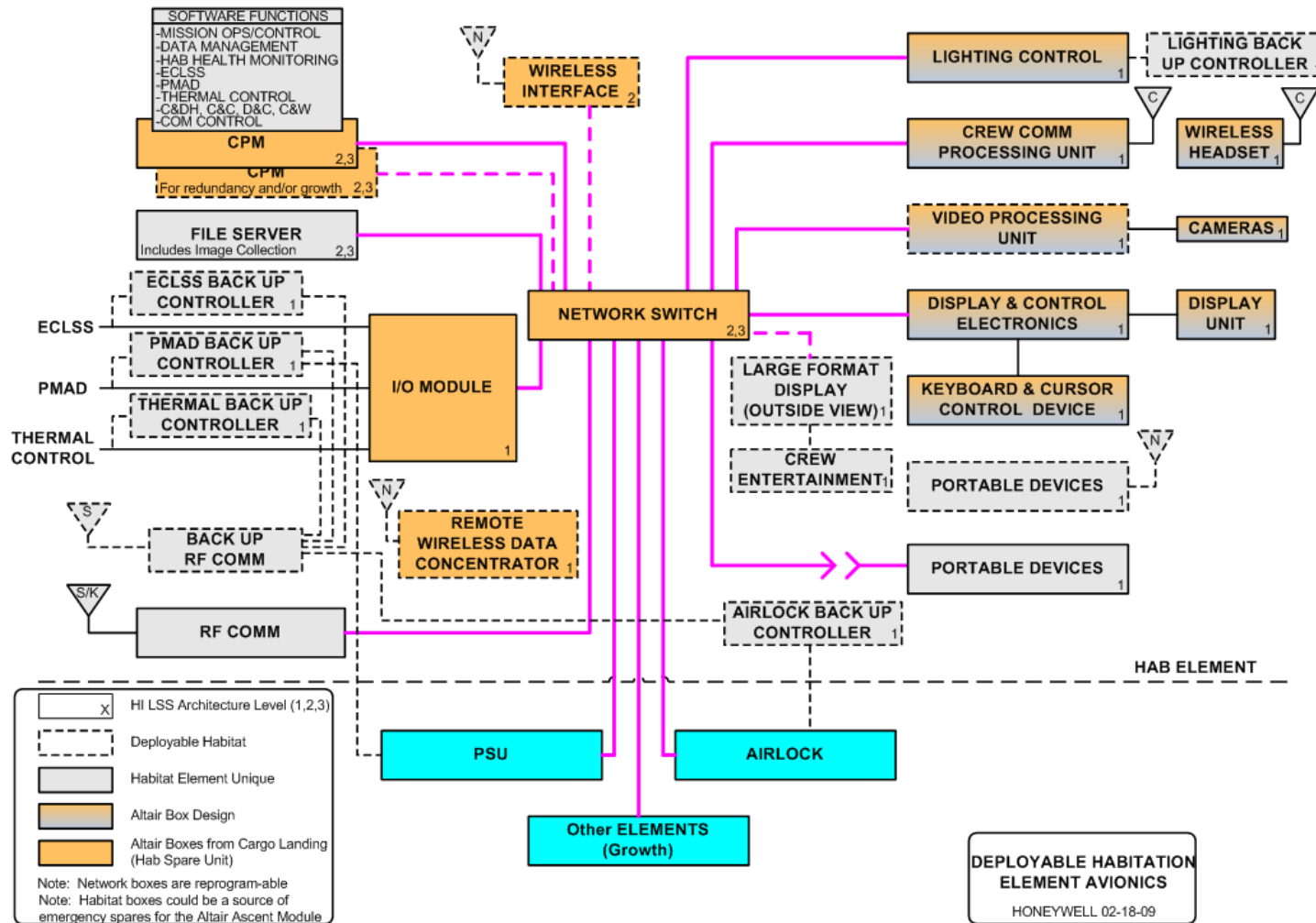

# Deployable Avionics Concept Details

Avionics Equipment	Qty	Mass (kg)	Volume (cuM)	Power (watts) continuous	Location (Internal/ External)	Cooling	Reuse	Notes		
Common Processing Module (CPM)	2	20	0.026	100	Internal	Cold Plate	Altair (1)	SW partition per function		
File Server	1	10	0.013	50	Internal	Cold Plate	(1)			
I/O Module	1	12	0.0156	20	Internal	Cold Plate	Altair (1)			
Network Switch	1	10	0.013	28	Internal	Cold Plate	Altair (1)			
Lighting Control	1	3	0.003	2	Internal	None	Altair (1)	Lighting control, not power		
Crew Comm Processing Unit	1	4	0.004	8	Internal	None	Altair	(2) Voice		
Crew Wireless Headset	4	1	0.0026	0	Internal	None	Altair	(2) Voice, table data for 4 units		
Display & Control Electronics	1	5	0.0065	20	Internal	Cold Plate	Altair	(2)		
Display Unit (13x10)	1	13	0.017	80	Internal	Cold Plate	Altair	(2)		
Keyboard	1	2	0.002	3	Internal	None	Altair	(2)		
Cursor Control Device	1	2	0.002	2	Internal	None	Altair	(2)		
Wireless Interface (Network)	1	10	0.015	15	Internal	Cold Plate	Altair (1)			
Remote Wireless Data Concentrator	1	10	0.015	25	Internal	Cold Plate	Altair (1)			
Portable Devices	1	3	0.004					(2)		
Video Processing Unit	1	10	0.013	50	Internal	Cold Plate	Altair (1)			
ECLSS Backup Controller	1	10	0.015	25	Internal	Cold Plate	(1)			
PMAD Backup Controller	1	10	0.015	25	Internal	Cold Plate	(1)			
Thermal Backup Controller	1	10	0.015	25	Internal	Cold Plate	(1)			
Airlock Backup Controller	1	10	0.015	25	Internal	Cold Plate	(1)			
Lighting Backup Controller	1	7	0.01	12	Internal	Cold Plate	(1)			
Large Format Display (32")	1	20	0.046	130	Internal	None		(2)		
Total		182	0.2677	645						
(1) Assume this equipment needed during all mission phases (Launch - End of Mission)										
(2) Only powered during crew visits										

# Dust Mitigation: Deployable

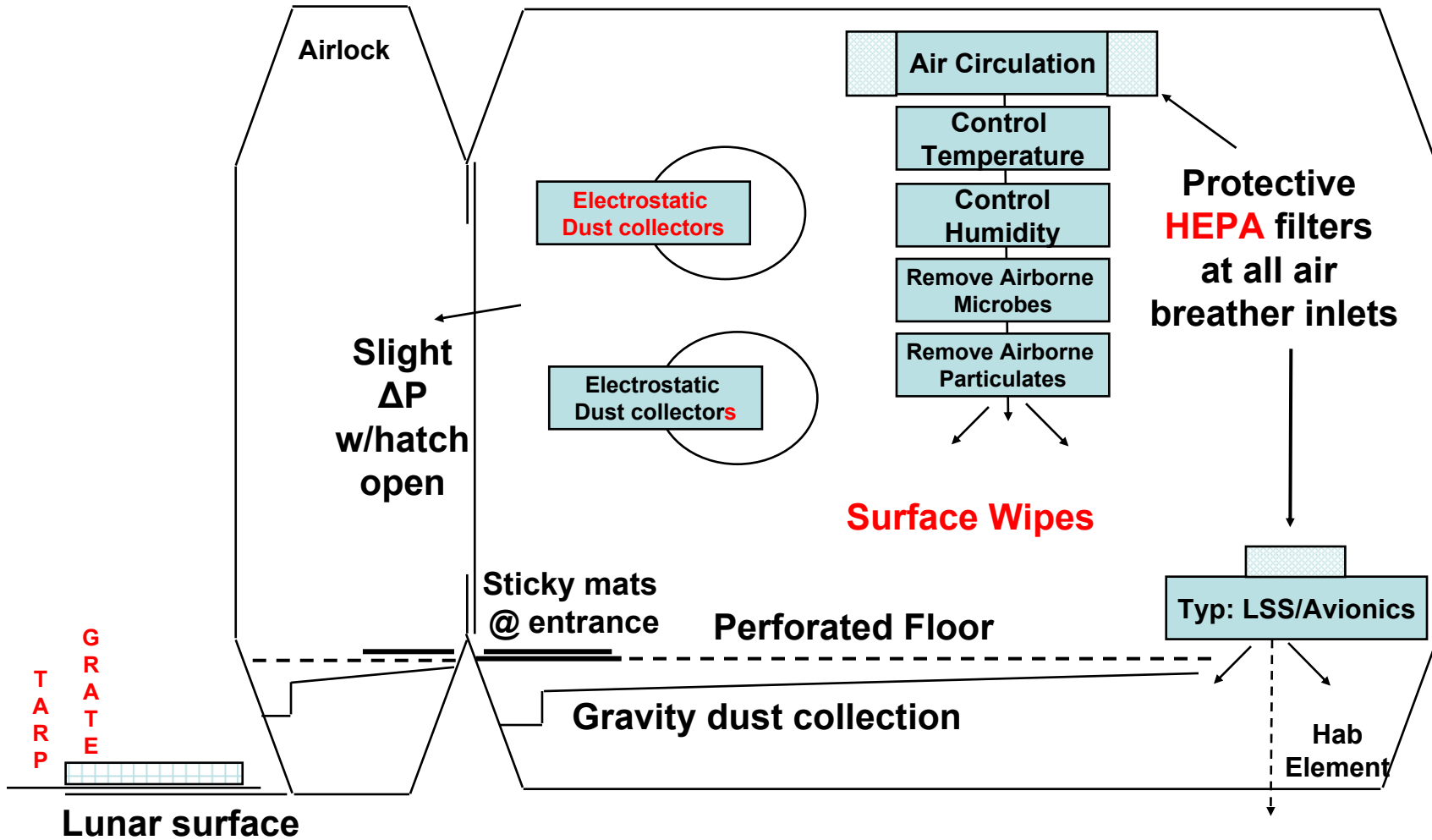

# Single-Fluid Dual-Loop Thermal Control Concept

Deployable goes to dual loop including internal equipment for redundancy.

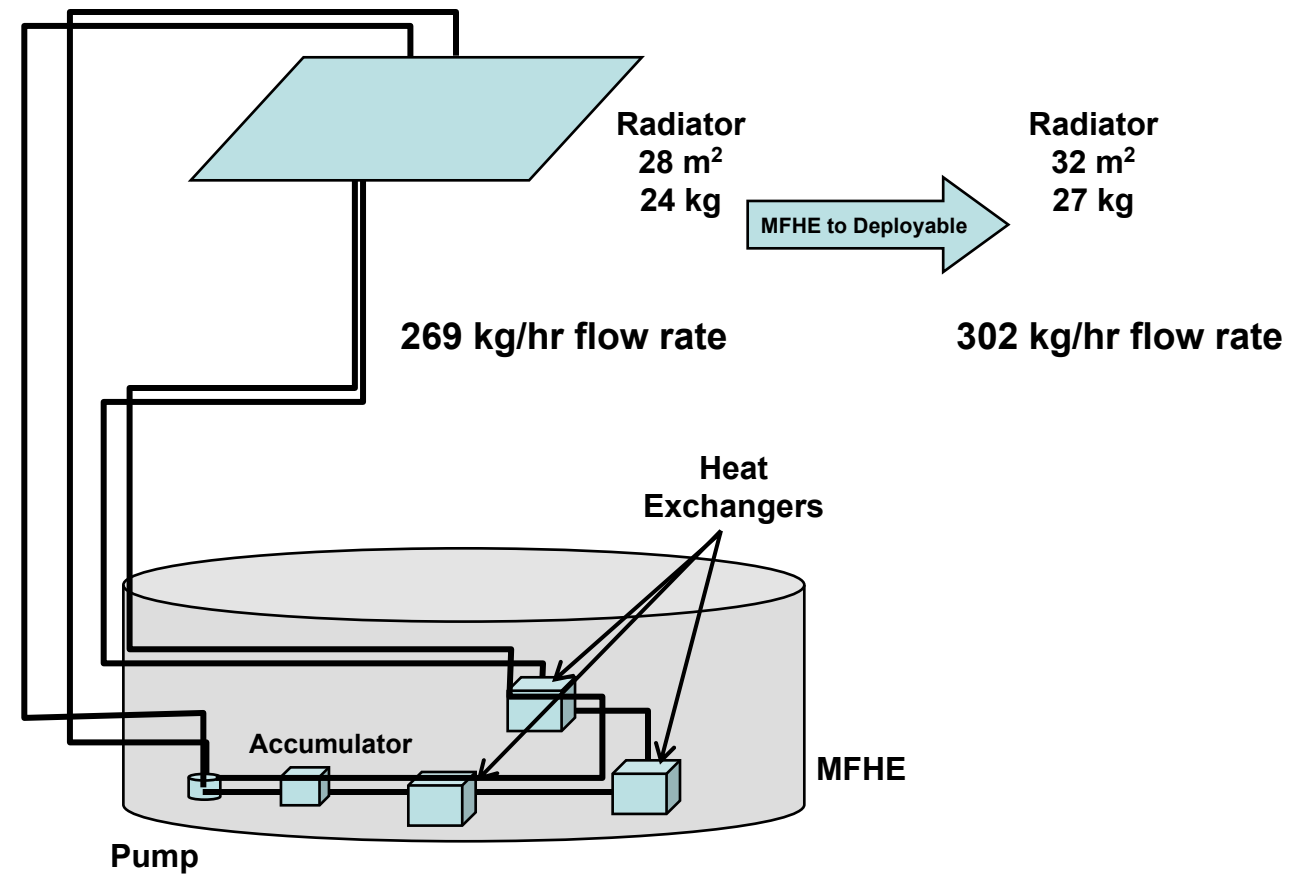

# Summary Deployable Low 28 + 30 Characteristics

Description	Qty	Mass (kg)	Int. Vol. (m3)	Ext. Vol. (m3)	Pk. Pwr (Watts)	Avg. Pwr (Watts)	Ht. Rej. (Watts)
Structure		5089	0.0000	0.0000	0	0	43
Avionics		230	0.3597	0.0000	905	788	
Communications		126	0.0692	0.0496	327	327	
Electrical Distribution		49	0.0000	0.0000	0	0	
ECLSS		243	0.5354	0.0224	748	368	
Thermal Control System		267	0.0000	0.0000	200	200	3415
Flight Crew Systems		71	2.3193	0.0000	315	315	
Work Stations		96	5.0758	0.0000	650	180	
28 Day Mission + 30 Day Contingency Logistics							
Logistics Pallet + Food		908	0.2787	2.2761	295	295	
Vented/Disposed (Info only; not in totals)		749	0.0000	0.0000	0	0	
28 Day Mission + 30 Day Contingency		7080	8.6381	2.3481	3440	2473	3458
Growth Allowance		733	5.0256	0.0000	1720	1237	1708
Flight Support Equipment (5%)		391					
<b>Total</b>		<b>8204</b>	<b>13.664</b>	<b>2.348</b>	<b>5160</b>	<b>3710</b>	<b>5166</b>

- Internal volume for subsystem components
  - Required, with 25% packing factor 0.8 m<sup>3</sup>
  - Available in lower dome 17.1 m<sup>3</sup>
- Internal area for subsystem components
  - Required, with 25% packing factor 24.5 m<sup>2</sup>
  - Available in lower dome (1 layer on shell) 27.4 m<sup>2</sup>

Growth: mass, structure - 15%; mass, components - 50%; power & heat rejection - 50%; packing factor - 25%

# Opportunities to Meet 7000 kg Constraint for Deployable Habitation Element

- **Current mass estimate with growth allowance: 7809 kg + 390 kg FSE**
- **Current mass estimate without growth allowance: 7077 kg**
- **Mass reduction opportunities**
  - **Radiation protection system (2230 kg) is a total independent solution**
    - **Potential savings not fully additive**
    - **Potential 900 kg assuming half of ISS internal outfitting protection**
    - **Movement of protection to entry floor could eliminate bottom mat from enclosure potential 700 kg savings)**
    - **Does not consider utilization of regolith for radiation and meteoroid protection (potential savings of ~1100 kg assuming top floors, walls, meteoroid shield, and internal outfitting provided adequate protection for top of ground floor shelter)**
  - **Full mass ISS CBMs (272 kg) and hatches (136 kg) each x quantity 4**
    - **Total mass 1600 kg**
    - **Due to 8 psi pressure and reduced dynamic loads for lunar surface, reduced structural loads anticipated allowing sizable mass reduction for actual hardware**
- **Anticipated savings on either of these restores “positive mass margin”**



# Growth Path



# Habitation Growth Path - 1

## ● Mission 6 - Cargo (Unpressurized Payload)

- Inflatable Module 750 kg
- Atmosphere Pallet for Inflatable Module ~800 kg

**Boeing  
Additional  
Growth  
Items**

## ● Mission 9 - Cargo (RPLM-1)

- Additional volume attached to Deployable Hab port #3
  - Total pressurized 55 m3
  - Habitable volume 33 m3
- Four private sleep stations
- Urgent Care capability with minor dental hygiene (Telemedicine)
- ECLSS, TCS, electrical power distribution
- CO2 reduction to carbon using methane pyrolysis
- Water electrolysis
  - Hydrogen production for CO2 reduction
  - Oxygen production
- Wet food, freezer, refrigerator
- Full galley
- Trash compactor

**Matches  
Scenario  
4.0.0**

**Boeing  
Additional  
Growth  
Items**

# Habitation Growth Path - 2

## ● Mission 12 - Cargo (RPLM-2)

<ul style="list-style-type: none"> <li>Additional volume attached to Deployable Hab port #1             <ul style="list-style-type: none"> <li>Total pressurized</li> <li>Habitable volume</li> </ul> </li> <li>ECLSS, TCS, electrical power distribution</li> </ul>	<p>55 m3</p> <p>33 m3</p>
<ul style="list-style-type: none"> <li>Surgical and dental capability</li> <li>Expanded scientific capabilities (includes 4.0.0 bioscience)</li> <li>Shower</li> </ul>	

**Matches Scenario 4.0.0**

**Boeing Additional Growth Items**

## ● Mission 15 - Cargo (DPLM-1)

<ul style="list-style-type: none"> <li>Additional volume attached to Deployable Hab port #2             <ul style="list-style-type: none"> <li>Total pressurized</li> <li>Habitable volume</li> </ul> </li> <li>ECLSS, TCS, electrical power distribution</li> </ul>	<p>55 m3</p> <p>33 m3</p>
<ul style="list-style-type: none"> <li>Clothes washer</li> <li>Dishwasher</li> </ul>	

**Matches Scenario 4.0.0**

## ● Beyond Mission 16

<ul style="list-style-type: none"> <li>Vegetable garden unit with biochemical life support</li> <li>Composting toilet</li> </ul>	
--	--

**Boeing Additional Growth Items**

# Growth Concepts – Rationale (1)

Functions	Function Type					Modifications to MFHE to produce Deployable / Growth Hab	Affected subsystems										
	Mission Support	Survival/Survivability	Safety/Protection from Environment	Deployable Hab	Growth Habitat		Avionics	Communications	ECLSS	Thermal Control System	Flight Crew Systems	Mission Ops / Mission Payloads	Power Management	Structures & Mechanisms	Logistics	Trash Management	Software impacts (allocated to subsystem)
Entertainment					X	Additional electronic equipment and display panels; volume for equipment; file storage capability for electronic media; other entertainment equipment per crew specification requires volume, power, launch mass					X			X			
Full Galley; Fresh/frozen food capability					X	Fridge / Freezer; stove & multifunction oven; power system support; volume for equipment	X		X	X	X		X	X	X	X	
Increased medical capability					X	Medical equipment; physical space for medical capability; storage for medical equipment; telemedicine support capability; medical equipment consumables	X	X			X		X	X			X
Increased Science capability					X	Additional work locations in outfitted logistics module; additional power; additional data storage; additional ground communication bandwidth; dedicated science facility (outfitted logistics module?) with small additional airlocks, etc.; cold storage capability; internal sample processing capability	X	X	X	X	X	X	X	X	X	X	X
Private quarters and outfitting					X	Room dividers in growth section; built-in furniture		X	X		X		X	X			X

# Growth Concepts – Rationale (2)

Functions	Function Type					Modifications to MFHE to produce Deployable / Growth Hab	Affected subsystems										
	Mission Support	Survival/Survivability	Safety/Protection from Environment	Deployable Hab	Growth Habitat		Avionics	Communications	ECLSS	Thermal Control System	Flight Crew Systems	Mission Ops / Mission Payloads	Power Management	Structures & Mechanisms	Logistics	Trash Management	Software impacts (allocated to subsystem)
Radiation Protection - GCR			X		X	Protection for full module (added logistics module or added shielding for deployed hab?) for radiation; outfitted as camp-out location	X	X	X	X	X	X	X	X	X	X	X
Reduced logistics with electrolysis & CO2 reduction					X	Electrolysis and CO2 reduction equipment; volume for equipment	X		X	X		X	X	X			X
Safe haven			X		X	Camp-out locations for various contingency scenarios; second habitable crew element such as outfitted logistics module or second hab would be required in most cases; radiation protection area could function as safe haven for some cases, but not all. Assured access to ascent module would be potentially required. Small pressurized rovers could serve as Safe Havens for specific cases.	X	X	X	X	X	X	X	X	X	X	X
Shower / improved hygiene					X	Hygiene equipment; physical space for hygiene capability; storage for equipment; consumable water or increased water purification capability; hygiene consumables.			X	X			X	X	X		
Appliances - Washer, dishwasher, trash compactor, other appliances					X	Mass, power, volume, logistics	X	X	X	X	X	X	X	X	X	X	X

# Integral and Add-on Volumetric Expansion

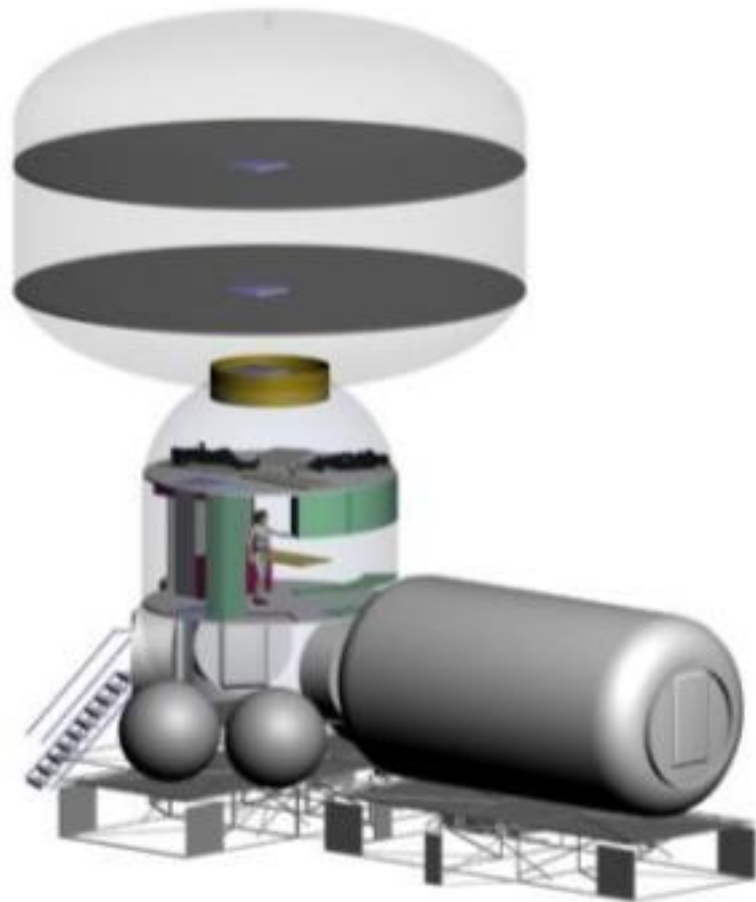

## Inherent Growth features of Deployable Hab

- Inflatable module interface on Deployable habitat
- Three hatches provide horizontal growth via pressurized logistics modules
- Power system current carrying capability
- Logistics pallets provide modularly scalable mission and growth options
- Dual-loop TCS allows growth opportunity
- Comm system allows over-the-horizon comm and nav for EVAs prior to LCT arrival
- Entry foyer accommodates suit maintenance and storage

# Direct Path From MFHE to Outpost Capability

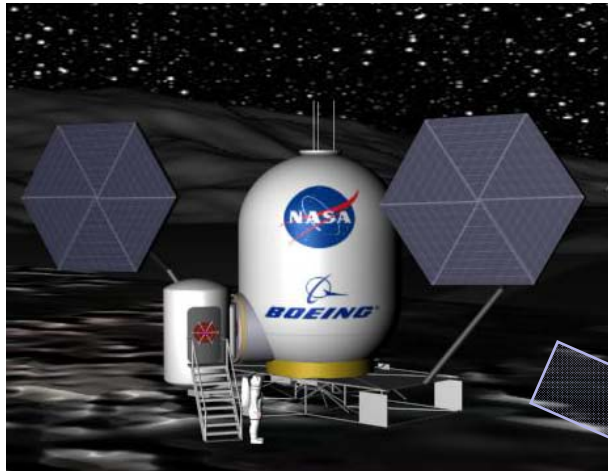

**Mission 5**

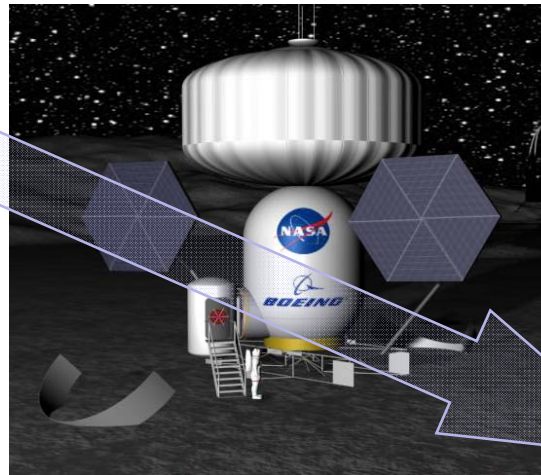

**Mission 7**

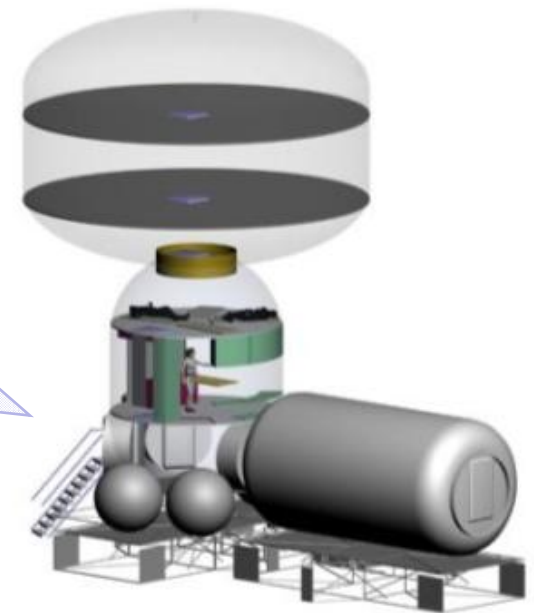

**Mission 10**

# Boeing MFHE Final Review Agenda

● Introductions	5
● MFHE Overview	25
● Functions and Subsystem Allocation	10
● Subsystems	40
● MFHE Variant Discussion	10
● Deployable and Growth Concepts	15
▶ Questions	15

# Potential Future Studies (1)

## ● Avionics

- Define interfaces between subsystems within habitat
- Define interfaces between habitat and other surface systems
- Commonality trade study across surface systems
- Operational modes from pre-launch through lunar surface operations

## ● Metal halide lights – safety trade-offs vs performance vs. actual function / operations (warm up time, noise, et. al., too bright to look at w/o heavy diffuser)

## ● Use of expended water tanks as subsequent mission waste water tank; could also potentially use Lander tank as waste water tank.

## ● Use rejected heat to keep external water tanks from freezing to avoid need for dedicated heaters

## ● Study water treatment requirements at potable water outlet – Is VCD output adequate or is upgrade / addition to off-the-shelf VCD required?

## ● Maximum volume achievable including structure, associated structural equipment, atmosphere gases, etc. within 7000 kg launch mass constraint; may be higher definition assessment of assumptions for MFHE outfitting (hatches, interfaces, etc.)



# Potential Future Studies (2)

- **Potential studies for mass savings**
  - Structural analysis for all environmental load cases
  - Lighter hatch and connector due to lower MHFE pressure relative to ISS
  - Lighter connector as no flight loads while connected
- **Potential studies to refine TCS concept**
  - Integrated systems analysis: TCS, ECLSS, Avionics, Communications, habitat, logistics pallet, etc
- **Potential studies for mass savings**
  - Structural analysis for all environmental load cases
- **Potential studies for mass savings**
  - Configuration-based radiation analysis
  - Entry foyer shielding vs pup tents
  - External, regolith-based protection against radiation and meteoroids
  - Integrated water wall



# Backup

# HI LSS Study Architecture (Technology Independent) Applicable to MFHE

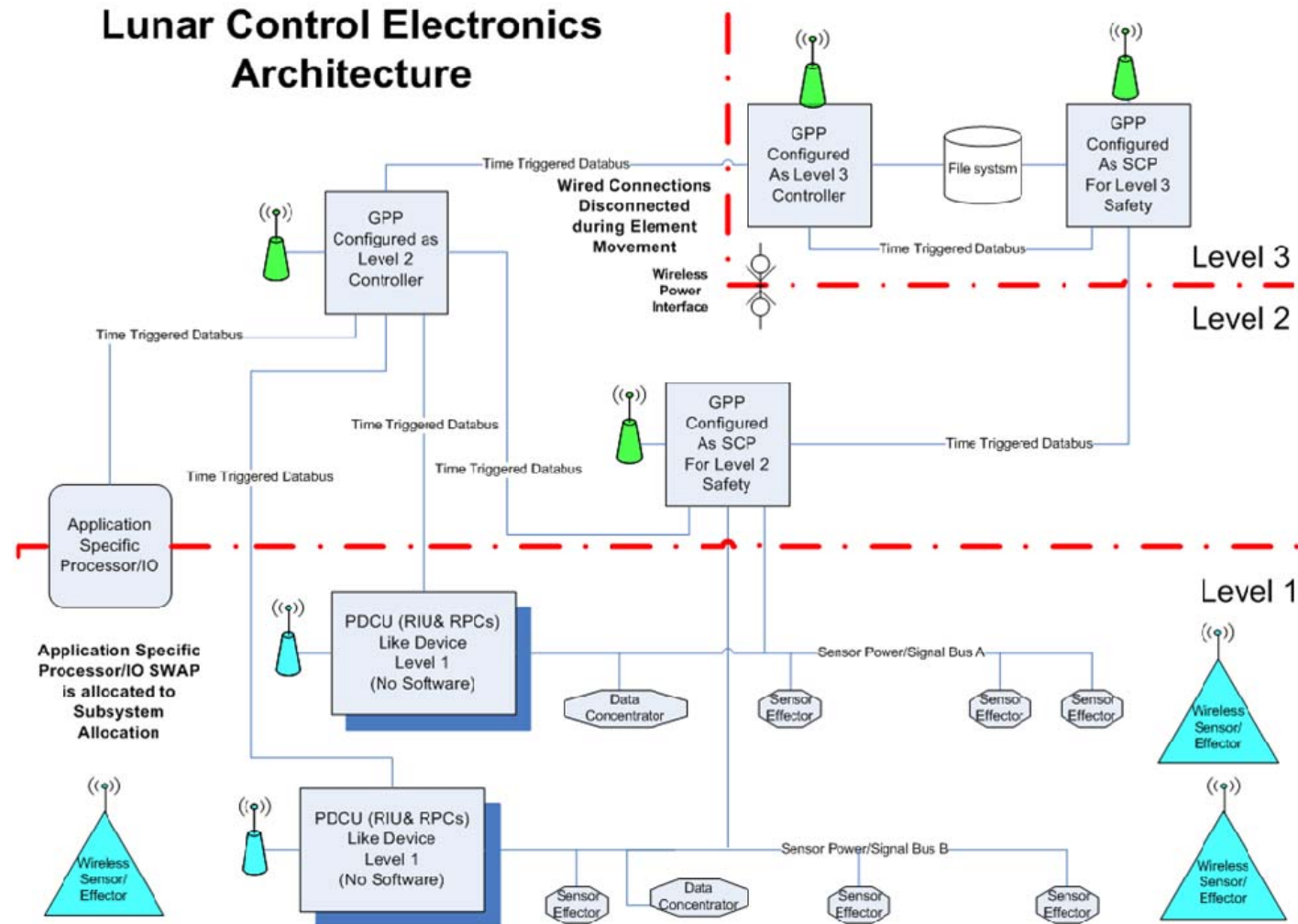

# Many Configurations Defined: Large & Small

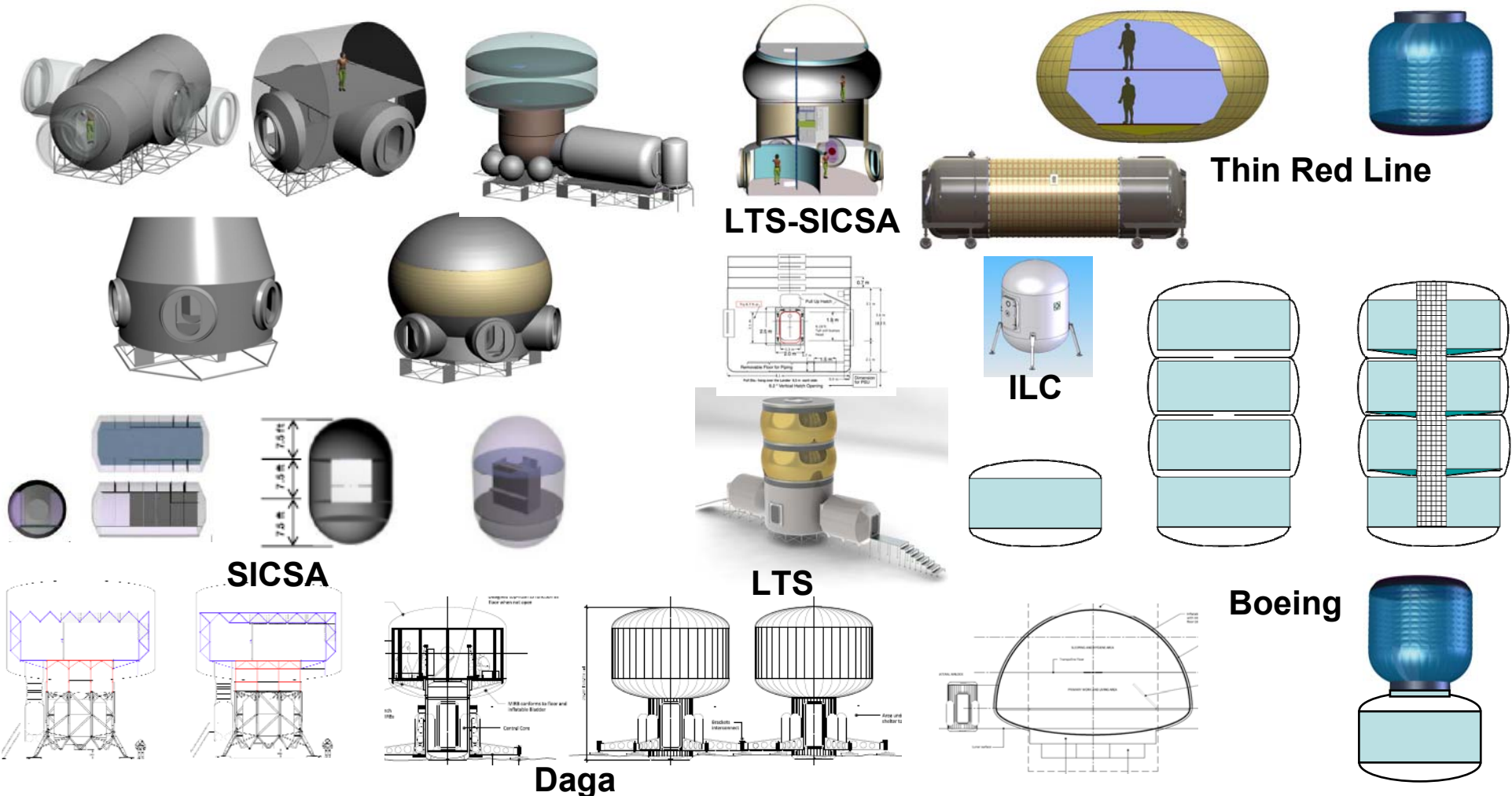

# Minimum Size by Configuration Layout - SICSA

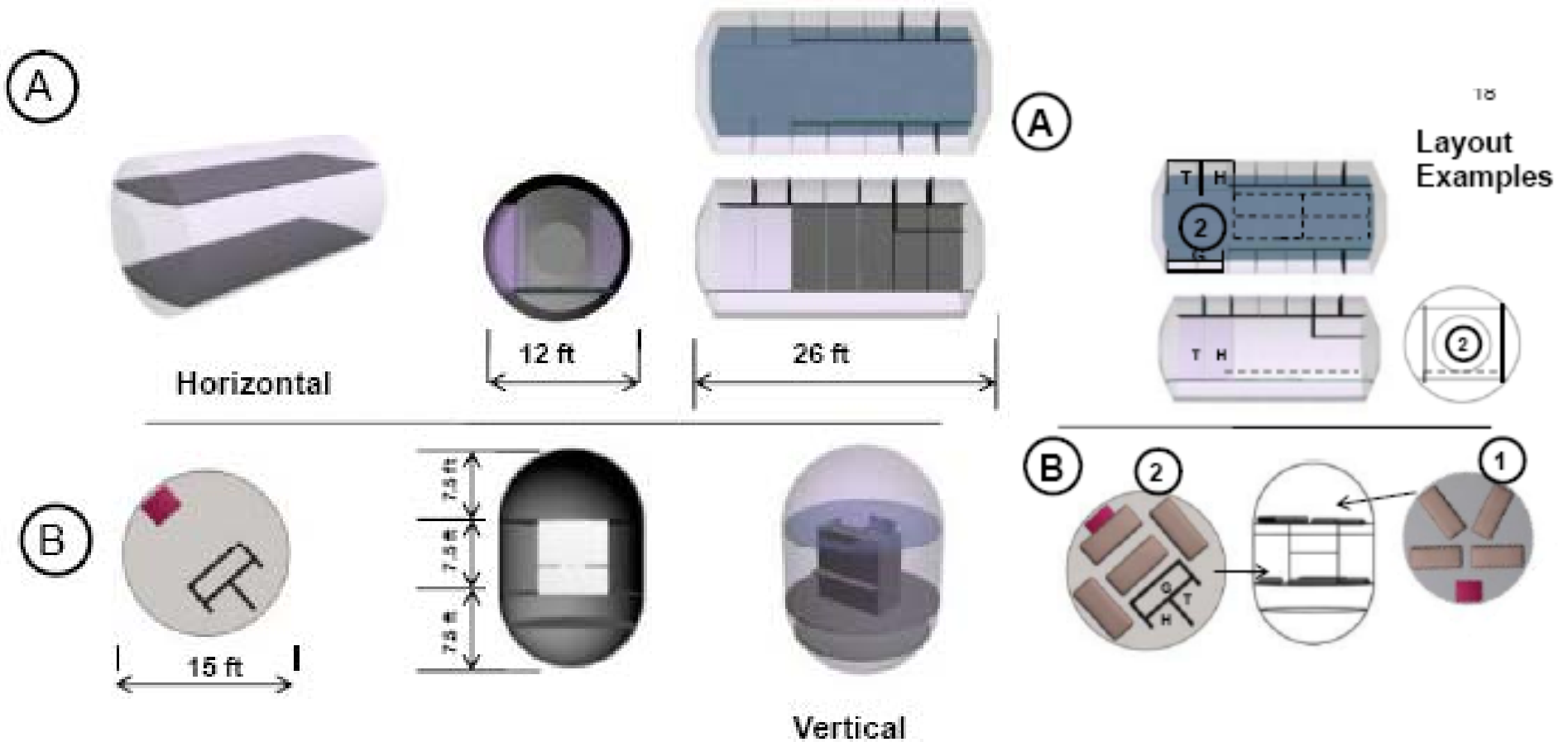

MFHE References

# Minimum Habitat Volume Configuration: Quantitative Approach - "Human Cylinders"

- Minimum Open Space Defined
  - 50<sup>th</sup> percentile + 3  $\sigma$  American male horizontal reach
  - 50<sup>th</sup> percentile + 3  $\sigma$  American male vertical reach

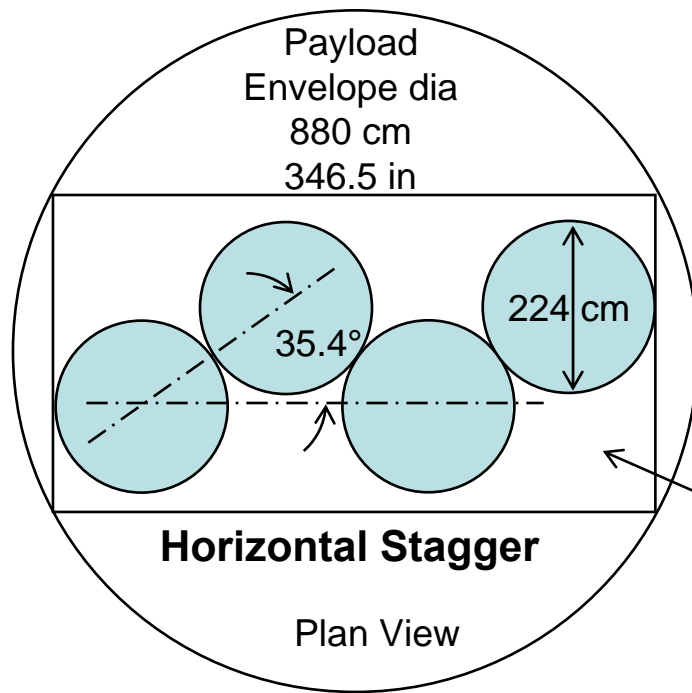

**Horizontal configuration**

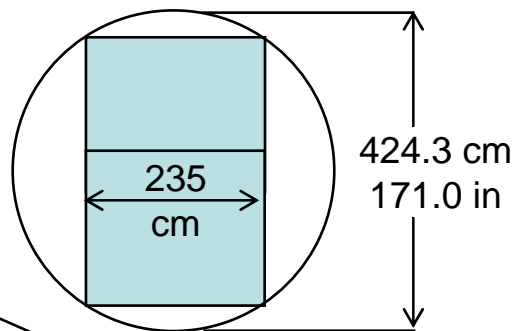

Available space for commode, food, workspace, etc

## Vertical configuration

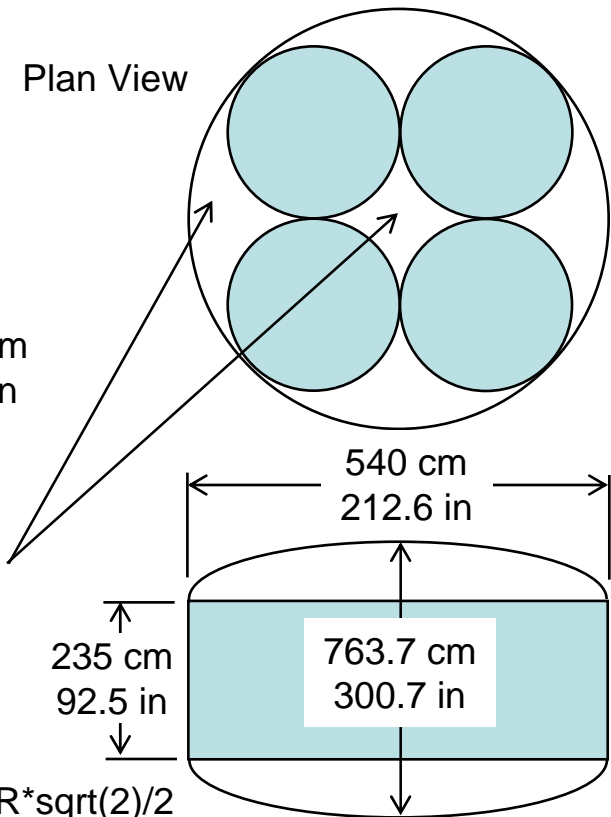

# Vertical MFHE Basic Dimensions Comparing Hemispherical and Radical 2 Domes

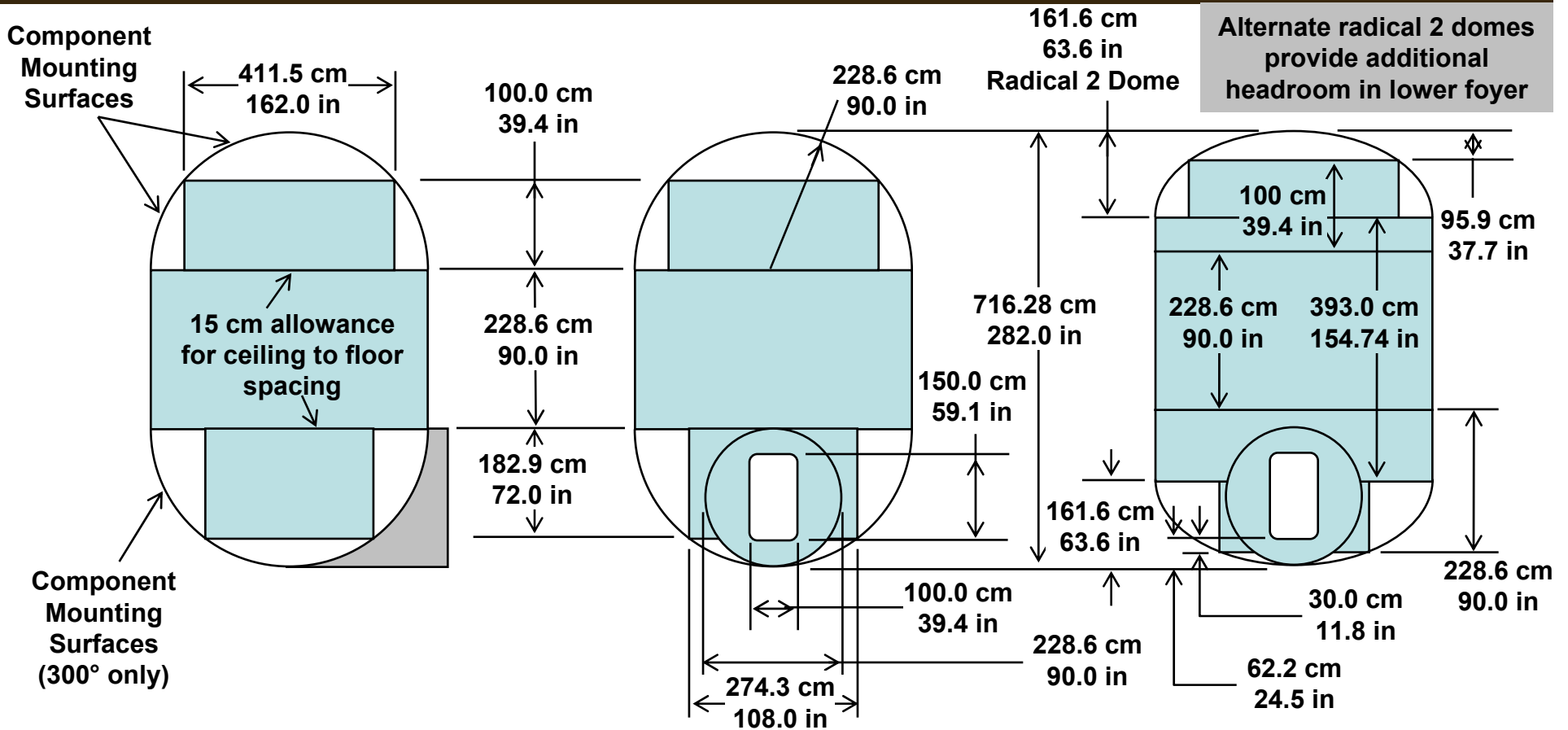

**Radical 2 domes don't change internal layout; increase entry foyer ceiling height; reduce component volume**

# MFHE Concepts Meet or Exceed Theoretical Optimum Volume; Eight Beat CxAT Goal

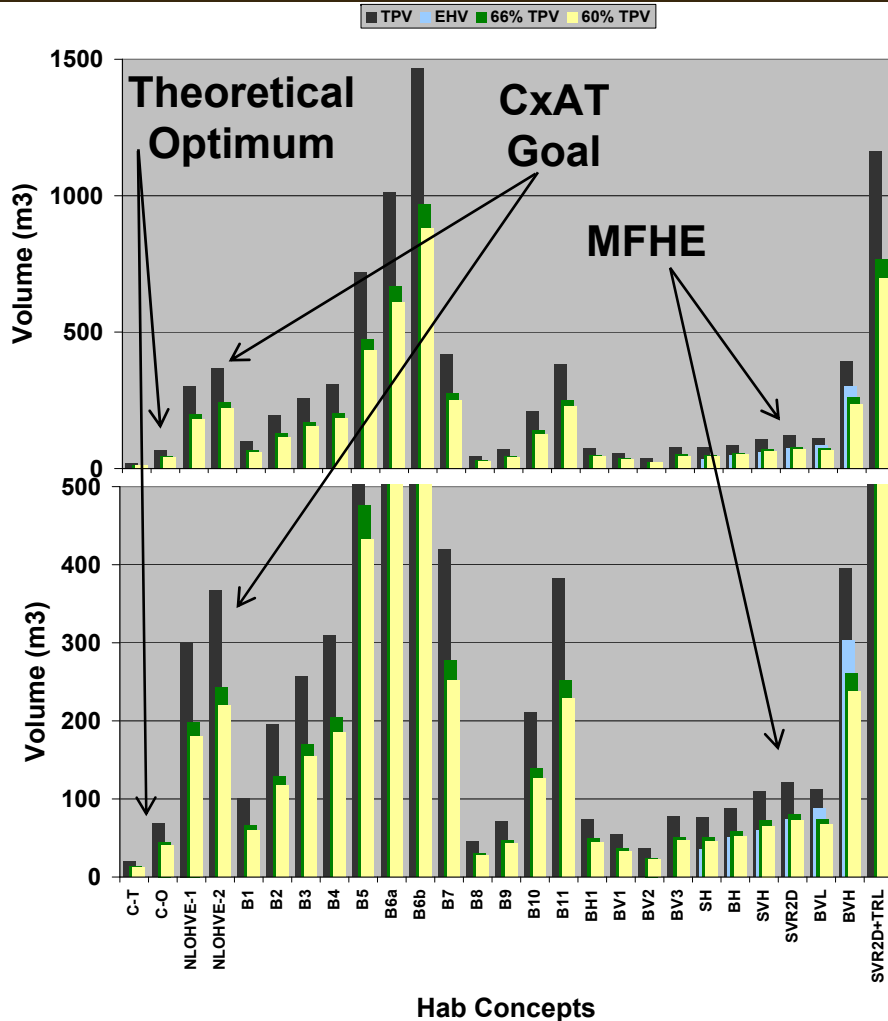

- Initial concepts B1 - B11 explored possibilities within shroud constraints
- Concepts BH1 - BV3 defined by “human cylinder” minimum open space
- SH - BVL compare small volume horizontal and vertical concepts with identical content
- BVH is an 8.8 m D single floor tuna can with radical 2 domes
- SVR2D is MFHE configuration
  - 121 m3 Total Pressurized Volume
  - 73 m3 (60%) net Habitable Volume
- SVR2D+TRL adds inflatable upper room for volume expansion during early missions



# Configuration Pros & Cons

## ● Vertical - Pros

- Separate entry, living, and sleeping floors

## ● Vertical - Cons

- Single exit path
- Higher cg
- Smaller PSU interface area

## ● Horizontal - Pros

- Longer internal sight lines
- Lower cg
- Larger PSU interface area
- Widely separated exits

## ● Horizontal - Cons

- Single entry, living and sleeping floor

## ● Small - Pros

- Less mass
- Reduced atmosphere loss

## ● Small - Cons

- Limited open space
- Larger thermal radiator
- Shorter response times
- Higher component duty cycles
- Less wall space

## ● Large - Pros

- More open space
- Smaller thermal radiator
- Longer response times
- Lower component duty cycles
- More wall space

## ● Large - Cons

- More mass
- Increased atmosphere loss

# Potential window configuration for deployable (ISS variant)

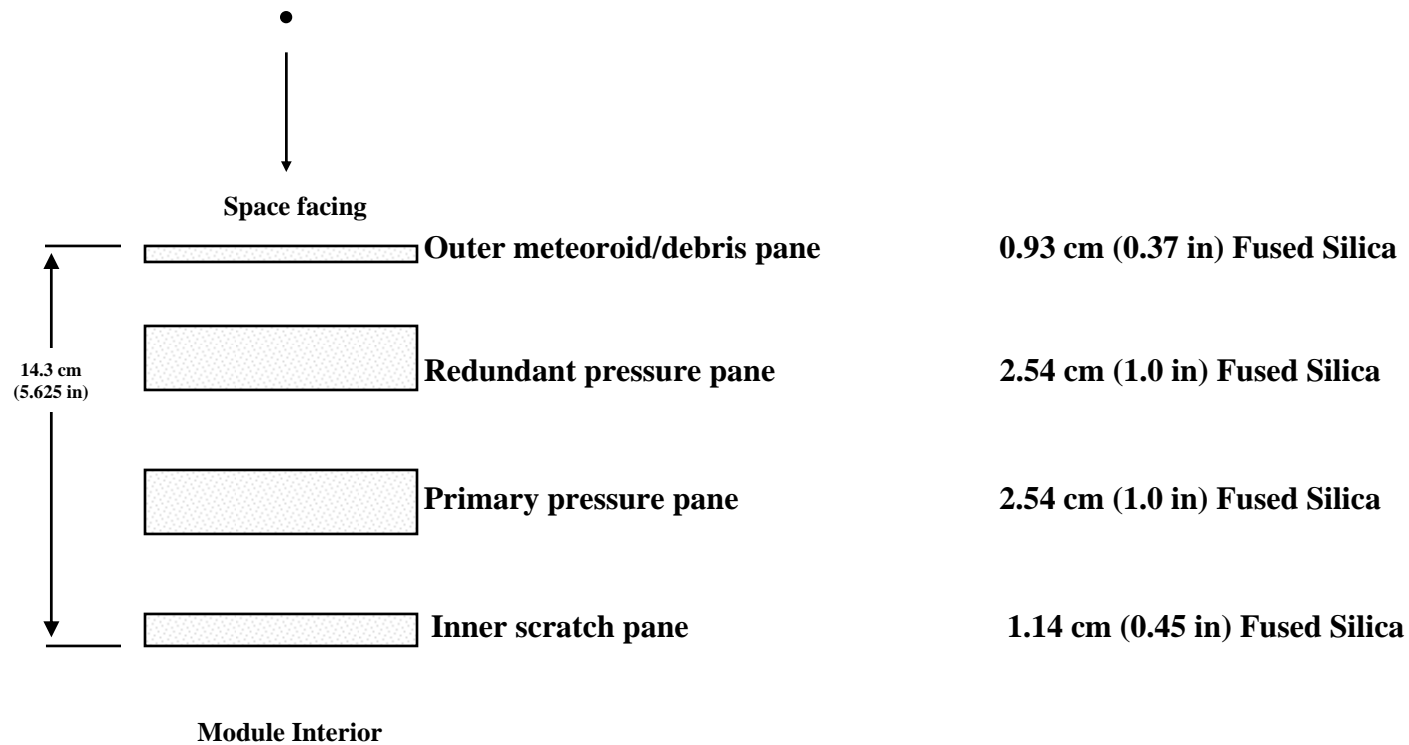

# Dust Mitigation: Growth

