

SIZING OF FINAL STUMPS FOR SAFER PILLAR EXTRACTION

Christopher Mark, Chief, Rock Mechanics Section
NIOSH, Pittsburgh Research Laboratory
Pittsburgh, PA

Joseph C. Zelanko, Mining Engineer
PS&HTC
Mine Safety and Health Administration
Pittsburgh, PA

ABSTRACT

Pillar recovery continues to be one of the more hazardous activities in underground coal mining. Safety requires that the roof above the intersection remain stable until after the pillar has been extracted. Artificial supports (timbers and Mobile Roof Supports) are essential to roof stability, but so is the final remnant stump or pushout. Traditional mining practices usually called for the complete extraction of the final stump, but the recent trend (both in the U.S. and internationally) seems to be towards mining plans that leave a remnant stump.

For this study, a sample of roof control plans from the Mine Health and Safety Administration (MSHA) Coal Districts were analyzed to determine current pillar recovery practices. Both full- and partial-extraction plans were included. Special attention was paid to whether plans require that a final stump be left, and whether requirements regarding the dimensions of the remnant stump are included. Foreign experience with final stumps is also summarized.

It seems that the risk of major pillar falls can often be reduced by leaving final stumps that are large enough to protect the intersection, but small enough that they do not inhibit the caving of the gob. Because final stumps are often irregular in shape, a new approach for estimating their strength is described. Analyses were conducted to assess the effect of seam height and depth of cover on the potential variation in the size of remnant stumps.

INTRODUCTION

Although rarely in the spotlight, pillar recovery continues to be an important segment of the U.S. coal industry. Technology developed during the last 15 years, particularly mobile roof supports (MRS) and extended cuts, have improved both safety and productivity. Pillar recovery appeals particularly to room-and-pillar mines that cannot achieve acceptable coal recovery from development mining only. Today, less than 10% of underground coal comes from the second mining of pillars (1).

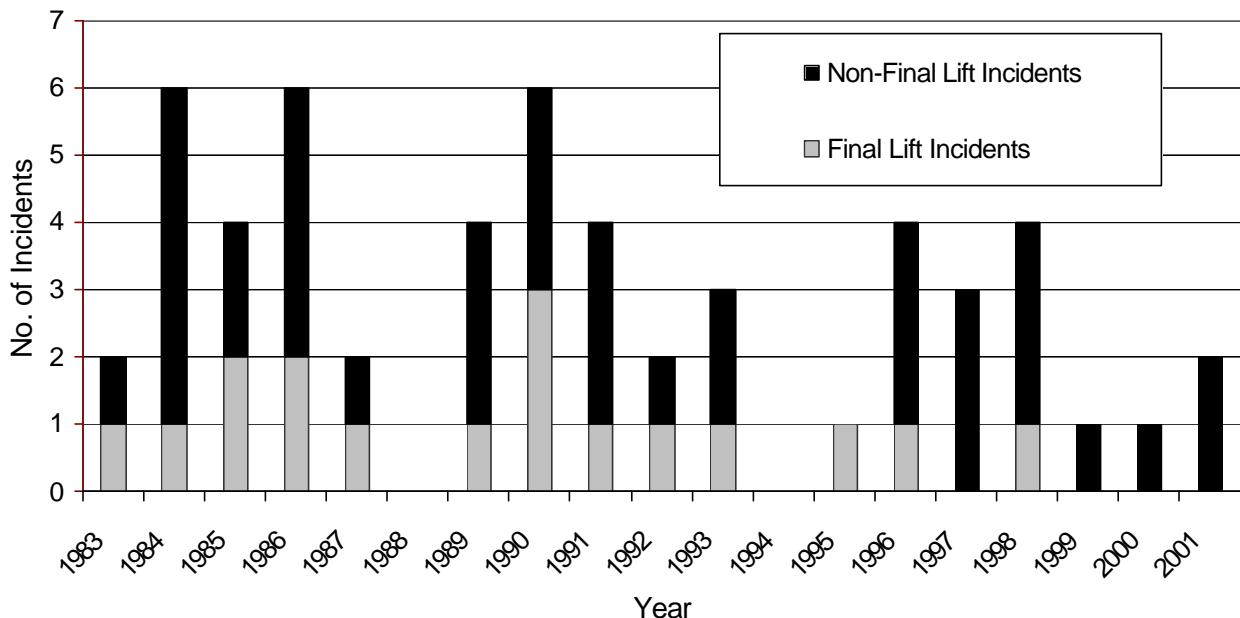

Figure 1. Fatal accidents occurring during pillar recovery operations, 1983-2001. Data current as of June 1, 2001.

In the past, pillar recovery has been associated with disproportionate rates of roof fall fatalities (1). Between 1980 and 1997, nearly 25% of all roof fall fatalities occurred on pillar sections. More than one-third of these took place during the mining of the final stump (or the last lift or pushout). The last five years, however, have seen a marked reduction in the number of pillar recovery fatalities (figure 1). More widespread use of MRS for roadway support can undoubtedly take some of the credit for the improvement. However, the authors believe that another important factor has been that more mines are using cut sequences that leave a final stump rather than trying to extract the entire pillar.

The goals of this paper are to document the role of final stumps in pillar recovery, and to help mine operators use them to reduce the risk of serious accidents. The paper begins with a discussion of the mechanics of pillar recovery. It then looks at recent trends in pillar recovery strategies, using representative Roof Control Plans from all the pertinent Districts. International experience with final stumps is also cited. Next, it analyzes MSHA Fatal Accident Reports involving final stumps from the past 18 years. The size of the rock fall, the size of the final stump, the mining sequence, and other key variables are evaluated. Finally, issues involved in sizing final stumps are discussed, and placed in the context of an overall pillar recovery strategy.

MECHANICS OF PILLAR EXTRACTION

Full pillar extraction has always involved a basic contradiction. On the one hand, the ground needs to cave to minimize the loads on the active pillar line. But on the other, the caving must not occur until after the miners have safely left the area.

The final stump is a critical element in this delicate balancing act (figure 2). While it is there, the stump helps protect the active intersection, which is generally the weakest link because of its wide span. Once the stump is removed, or is made too small to provide support, the intersection may become unstable—like a chair with one leg removed.

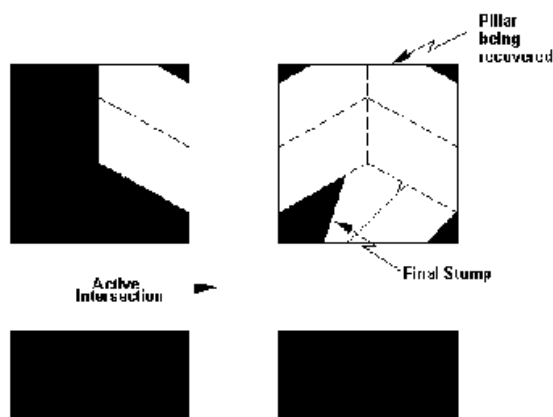

Figure 2. Typical retreat mining geometry, illustrating terminology used in this paper

Traditionally, however, miners have been reluctant to leave the final stump because they were concerned that caving might be inhibited. The conventional wisdom was that unless the pillars were totally extracted, the stumps left in the gob would provide too much support and would cause the rock to hang up. The extra “pressure”

would then be thrown on the outby pillars, resulting in a “ride” or “squeeze” (2, 3). Final stumps were only to be abandoned when poor roof conditions made their recovery too risky. This meant that the foreman and mining crew often had to make a difficult decision on a pillar-by-pillar basis, and a wrong choice could prove disastrous.

Recent experience seems to indicate that the fears about leaving stumps may have been exaggerated. Even 10 years ago several large companies were routinely leaving the final stump for safety reasons. Throughout the 1990's more mines adopted 3-cut and other mining sequences that left significant stumps of coal in the gob. Yet the incidence of squeezes does not seem to have noticeably increased. Better pillar design and faster mining rates may have helped. But it also seems that small stumps may not provide as much overburden support as had been thought. In many cases, it appears an optimum pillar extraction plan may be one that purposely leaves a final stump sized to provide roof support without inhibiting caving.

REGULATORY ISSUES

Several elements of 30 CFR 75, Mandatory Safety Standards-Underground Coal (4) deal specifically with pillar recovery operations. According to ¶75.220(a)(1), “Each mine operator shall develop and follow a roof control plan, approved by the District Manager, that is suitable to the prevailing geological conditions, and the mining system to be used at the mine.” The roof control plan must contain technical information regarding the method of pillar recovery and the sequence of mining pillars (¶75.221(a)(8)).

Pillar recovery criteria and specific criteria to be considered in the approval of the pillar recovery portion of the plan are identified in two sections of the standard. Section ¶75.207 discusses the use of breaker and turn posts, and the use of a single, 16 ft wide roadway to access the final stump. Section ¶75.222(d) addresses pillar dimensions, the width of splits and lifts, and the spacing of posts. These criteria generally reflect successful experience at a majority of mines. Some provisions were included as criteria rather than mandatory safety standards because MSHA recognized that individual criteria may not be appropriate for all mines due to the various geologic conditions encountered (5). The regulations have always purposely left the District Manager considerable discretion to account for local conditions and new technologies (3, 6).

Prior to 1988, 30 CFR 75 drew a distinction between “full” and “partial” pillar recovery. Full pillaring was defined as extraction that allows total caving of the main roof, while partial pillaring left sufficient coal in place to support the main roof and minimized the possibility of undue forces overriding the working places. However, many pillar plans fall between these two extremes, and the distinction can be blurred and confusing. This language was removed when the roof control regulations were revised and implemented in 1988.

PILLAR RECOVERY PRACTICE IN THE U.S. IN 2001

The popularity of room-and-pillar retreat mining varies substantially across the U.S. Currently, pillar recovery provisions are included in approved roof control plans in ten of eleven Coal Mine Safety and Health Districts nationwide. Pillar recovery operations are most common in mines in the central and southern Appalachians (Districts 4, 5, 6, and 7). Western mines (District 9) and those in the northern

Appalachians (Districts 2 and 3) have a greater abundance of reserves which can be longwalled. In these areas, longwall retreat has become much more common than room-and-pillar retreat for high recovery mining. One operator currently practices mechanized pillar recovery in the anthracite region of northeast PA (District 1) and several operators perform limited secondary mining (pillar splitting or perimeter mining) in the Illinois Basin (District 8). No pillar recovery operations are active in District 10 (Western Kentucky) and District 11 (Alabama) at this time.

For this evaluation, representative roof control plans were obtained from each pertinent MSHA district. Many mining companies maintain pillar recovery provisions in their roof control plans despite the fact that they do not rely on it as a primary production method. All 26 of the mines selected for this study were chosen to reflect operations which were actively engaged in pillar retreat mining. The provisions were evaluated in terms of pillar extraction method (e.g., pillar dimensions and cut sequence) with particular focus on criteria associated with pillar remnants.

By far the most popular methods of pillar recovery utilized at the subject mines were those which required no additional roof bolting during retreat. Fifty percent of the mines incorporate some form of Christmas tree (figure 3), 42% use outside lifts, and another 23% use a three-cut or some other form of unbolted slab cut. In contrast, split and fender and pocket and wing methods were used at 19% and 8% of the mines, respectively.

Of 26 roof control plans considered, nine contained provisions for a single pillar recovery plan. The remaining 17 plans each incorporated several different recovery plans. An individual mine may maintain multiple recovery plans for a variety of reasons. For example, outside lift plans are typically only used when the pillars are less than 40 ft wide. If deeper cover requires increased pillar dimensions, the mine may use Christmas tree or split and fender methods to achieve similar recoveries. Several plans might also be necessary to accommodate changing roof conditions or to respond to equipment problems (like an inoperable MRS unit). In other cases it appears that multiple plans were needed to accommodate various equipment types (e.g., one section uses shuttle cars, another uses continuous haulage). At other mines, different plans were developed for various support types (e.g., timber versus mobile roof supports).

Analysis of the plans suggests that remnant pillar sizing varies considerably among room and pillar retreat mines. Thirteen plans (from eight mines) could be considered partial pillar plans; these operations usually involve only pillar splitting or minimal slabbing. Twenty-four plans (from nine mines) contain provisions for taking the pushout while 38 plans (from 18 mines) leave the final stump. Of those 38 plans, 32 (from 14 mines) specify dimensions of the final stump; 11 mines have plans that call for minimum dimensions of at least 8 ft, while 8 have plans that call for minimums of less than 8 ft.

In many instances, the final dimensions of remnants including the pushout are not stated explicitly in the pillar recovery provisions of the roof control plan but are constrained nonetheless by the cut sequence and pillar dimensions. These implicit dimensions can be effective under usual circumstances but can easily be influenced by changes during the mining process. For example, even relatively small changes in fender thickness or angle of attack could compound in successive cuts and result in an undersized pushout. Specified minimum

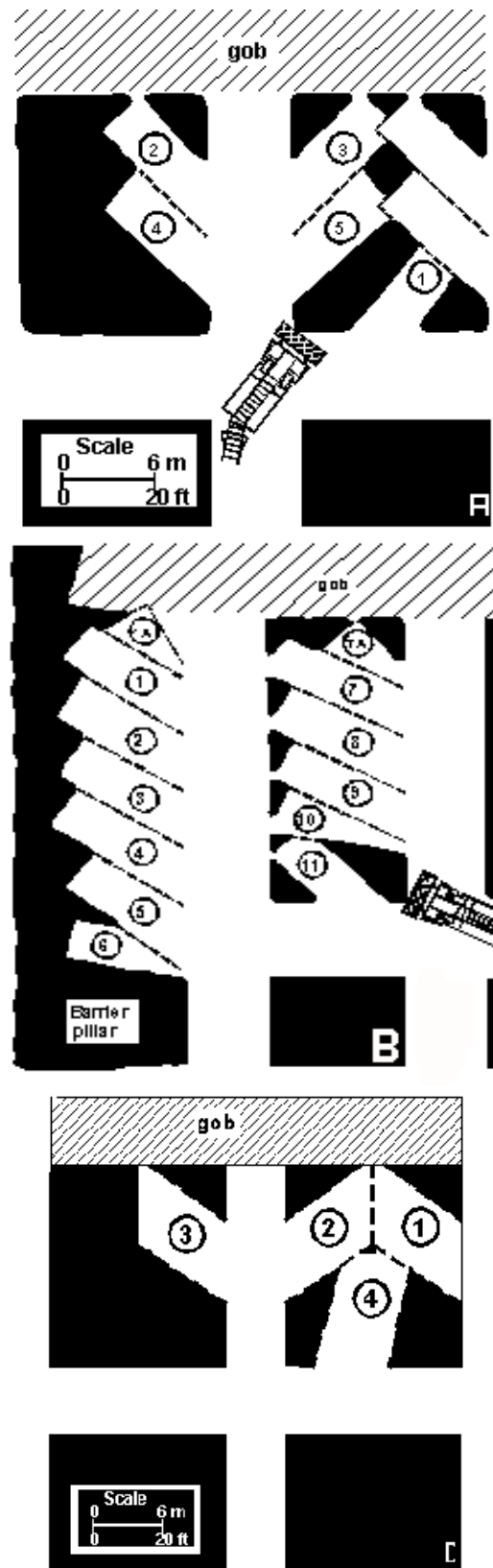

Figure 3. Pillar extraction mining methods; (a) Christmas tree, (B) outside lift and (C) three cut

dimensions may be preferable since they help ensure a prescribed minimum amount of support for the final lift.

It is interesting to compare current pillar recovery plans with those used in the past. During the late 1970's, MSHA roof control plans were evaluated as part of a U.S. Bureau of Mines (USBM) contract study of pillar extraction techniques (7). The results were later summarized in USBM information Circular 8849, "Room and Pillar Retreat Mining, A Manual for the Coal Industry" (6). The study found that about 38% of all U.S. mines employed room and pillar retreat methods at that time and these mines accounted for about 19% of the total U.S. underground production (7).

The report divided the various retreat mining methods into the broad headings "full" and "partial" recovery. Of the full retreat operations, the primary recovery methods were split and fender (73%), pocket and wing (17.2%), and outside lifts (6.2%). The main partial recovery methods were pillar splits (81%) and outside lifts (15.2%).

Clearly, pillar recovery techniques have changed dramatically during the past 20 years. The most obvious change is that few of today's plans require roof bolting while the pillars are being extracted. The widespread adoption of remote control operation of continuous mining machines, which makes it possible to mine "extended cuts," is responsible for this change.

MRS (or breaker line supports) are another technological development that has influenced recovery methods. Since their commercial introduction in 1988, the number of mobile roof supports in use in the U.S. has grown to about 50 sets (8). Other technologies such as continuous haulage systems, also have influenced pillar recovery methods.

INTERNATIONAL PILLAR RECOVERY PRACTICE

In South Africa, pillar recovery is the primary method of retreat mining. As in the U.S., miners there traditionally attempted total extraction of every pillar (9, 10). However, when the mining industry shifted from the thin seams in KwaZulu-Natal to the thicker seams in Mpumalanga and the Free State, total extraction was found to be unfeasible. As an alternative, the concept of "high extraction" was developed. With high extraction, final "stooks" (stumps) of pre-determined size are left in planned locations. The goal is to leave stumps that are large enough to support the intersection, but small enough to fail once they are in the gob (11). Typically, the final stumps measure 13 by 20 ft in a 13 ft high seam (12).

In Australia, where seams have always been thick, general practice has been to leave the final "stook x." In recent discussions with Australian pillar recovery specialists, the following general guidelines emerged:

- In *weak top*, the minimum stook x dimension is about 6 ft. Since the pillars are typically 30 ft wide, and the inby edge of the final stump measures about 12 ft, the total area is about 270 ft². In fractured ground, the minimum dimension may be increased to 8-10 ft.
- In *strong top*, no final stump is needed under normal conditions. However, 6 ft stumps will be left **before** the first fall or whenever caving is not occurring regularly.

Under deeper cover (1,000 ft in the South Coast mines for example), stumps as large as 750 ft² may be left. However, these are expected to crush out in the gob. In general, hard strong sandstones that bridge for long periods are considered the most difficult conditions.

Table 1. Pillar extraction fatalities occurring during mining of last lift or final stump

Year	State	Seam	No. of fatalities	Mining method ¹	Roof type	Seam height, ft	stump area, ft ²	Size of fall, tons	Fall type ²
1998	CO	Upper D	2	OL	siltstone	9	140	1950	1
1996	WV	Beckley	1	CT	shale	7	150	1000	1
1995	WV	Coalburg	1	CT	sandstone	8	65	38000	2
1993	WV	Poc. No. 3	1	CT	shale	5	70	600	3
1992	WV	U. Dorothy	1	CT	sandstone	7	100	2200	1
1991	WV	Hernshaw	1	CT	shale	4.5	40	1000	1
1990	KY	Creech	1	-	shale	3	20	2000	1
1990	KY	Highsplint	1	S&W	shale	5	200	5000	1
1990	PA	Pittsburgh	1	S&W	sandstone	10	180	?	?
1989	KY	U. Hignite	3	CT	? (slip)	5	120	450	3
1987	WV	Dorothy	1	S&T	shale	7	140	3200	1
1986	KY	"B"	1	S&W	sandstone	3.5	100	170	3
1986	VA	U. Banner	1	S&W	shale	5	40	4000	1
1985	WV	Coalburg	1		shale	6	175	200	3
1985	WV	Gilbert	2	S&W	shale	4	?	12500	2
1984	VA	L. Banner	1	S&W	sandstone	3.5	0	2000	1
1983	WV	Coalburg	1		shale	6	20	1700	1

¹Mining Method: OL=Outside Lift; CT=Christmas Tree; S&W=Split and Wing

²Fall Type: 1=Intersection Falls; 2=First Falls; 3=Small Falls.

ANALYSIS OF PILLAR RECOVERY FATALITIES

Roof falls that occurred during pillar extraction have claimed the lives of 67 miners since 1982. Of these, 21 were killed in 17 separate incidents involving the final stump or last lift. Details of these final stump fatalities are contained in table 1.

The final stump fatalities can be divided into three groups according to the type of roof fall involved:

Intersection collapses: These 10 incidents are the ones that most clearly might have been prevented by properly sized final stumps. They involved roof falls of 1,000 to 5,000 tons. In some cases, the final stump may have been too small, or it was in the process of being extracted. In other cases, the final stump appears to have been in the wrong place, resulting in an excessive span.

First falls: First falls are a special case of intersection falls. There have been two since 1982, and each involved a very large volume of rock. Stronger final stumps probably could not have prevented such falls from occurring, but they might have been able to break them off in by the active intersection.

Small falls: In 5 of the incidents, the size of the fatal rock fall weighed less than 1,000 tons. Such small loads clearly did not cause the failure of the final stump. Indeed, they are similar to the typical fatal roof falls that occur earlier in the retreat mining process. Such falls are caused by the stress redistributions and deformations that accompany pillar recovery. A stump that is too small might indirectly contribute to such falls by allowing too much deformation to occur.

The size of the final stump at the time of the roof fall was evaluated from the figures included with the reports. These figures are often not to scale, so the dimensions must be considered as estimates. In 5 of the 10 intersection collapse cases, the stump was less than 50 ft². In three cases, it was about 150 ft², and in one case it was 200 ft². The incident with the largest final stump also involved the largest volume of rock in the fall, 5,000 tons.

Some other characteristics of the fatal final stump roof falls are:

Roof quality: Most of the fatal roof falls occurred where the roof was shale or other weak rock. Surface cracks near the outcrop were a factor in four of the incidents, but the most recent one was in 1990. Horsebacks are mentioned in several incidents.

Mining method: The Christmas tree method has been disproportionately represented in recent years. Christmas tree mining can result in wider spans, particularly if mining is conducted too close to the active intersection on both sides of the entry. The outside lift method was only involved in one fatal incident.

Roof support: Only one of the final stump fatalities involved MRS. That case was also a first fall in which a relatively small stump was left. Perhaps most important, the MRS were not placed in the intersection where they could have done the most good (13).

SIZING THE FINAL STUMP

It seems that under many circumstances, a properly sized final stump could reduce the risk of a hazardous premature roof fall. The

purpose of this section is to provide information that can assist mine operators in sizing final stumps that are:

- Large enough to provide effective support to the roof above the intersection, but;
- Small enough that it does not prevent the main roof from caving.

The basic elements of any pillar design problem are the *applied load* and the *pillar strength* (or more precisely, the pillar load-bearing capacity). The final stump problem is unique because of the geometry of both the load and the stump itself.

The loading applied to a final stump is much less than the full overburden loading that a typical pillar carries. Calculated capacities clearly are smaller than tributary area load, indicating that these pillars must have shed much of their load (including transferred abutment load) to adjacent unmined pillars. However, the capacity provided by the remnant may still be sufficient to afford substantial support for the adjacent intersection. From the fatality report data presented in table 1, it appears that an approximate design load might be about 4,000 tons.

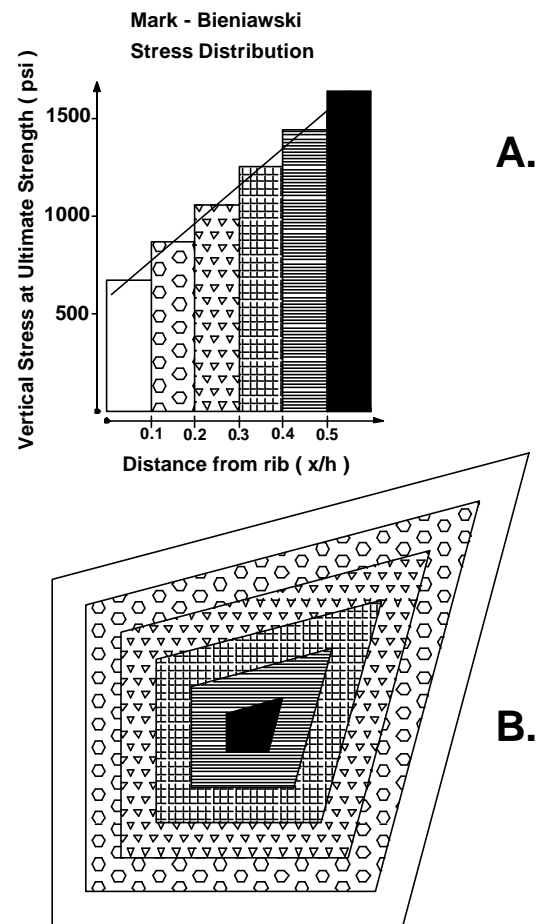

Figure 4. (A) Pillar stress distribution (cross-section to the pillar core). (B) Plan view of the stress distribution.

The load-bearing capacity depends on the strength of the stump and its load-bearing area. Traditional pillar strength formulas cannot be used directly because of the odd shape of the stump. However, the “method of slices” (figure 4) provides an approximation of the load bearing capacity, provided two assumptions are made (14):

- The strength of any pillar element is a function of its distance from the nearest pillar rib, and;
- The strength function is known.

For example, the Mark-Bieniawski stress function is:

$$\sigma_v = S_1 [0.64 + 2.16 (x/h)]$$

Where:

- σ_v = Pillar stress function
- S_1 = In situ coal strength
- x = Distance from the nearest pillar rib
- h = Pillar height

The load-bearing capacity of each slice is determined by multiplying the area of the slice by its vertical stress at ultimate strength. The total load-bearing capacity of the stump is the sum of the load-bearing capacity of the slices.

The area of a final stump depends on cut-to-corner distances L_1 and L_2 , and on the cut angles ϕ_1, ϕ_2 (figure 5). A spreadsheet program was prepared that calculates the stump area for any combination of these parameters.

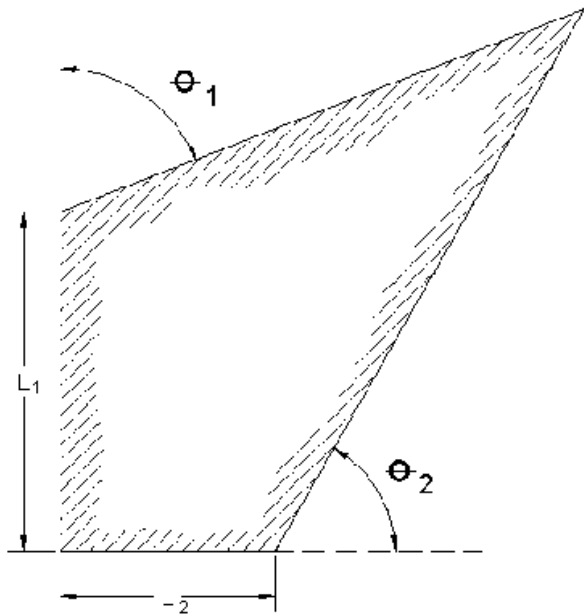

Figure 5. Determination of the load-bearing area of the final stump

Figure 6 shows the load bearing capacities of stumps for a variety of seam heights and cut-to-corner distances. It assumes that $L_1 = L_2$, and $\phi_1 = \phi_2 = 75$ deg. It appears that stump capacity is very sensitive to the cut-to-corner distance, and less sensitive to the seam height.

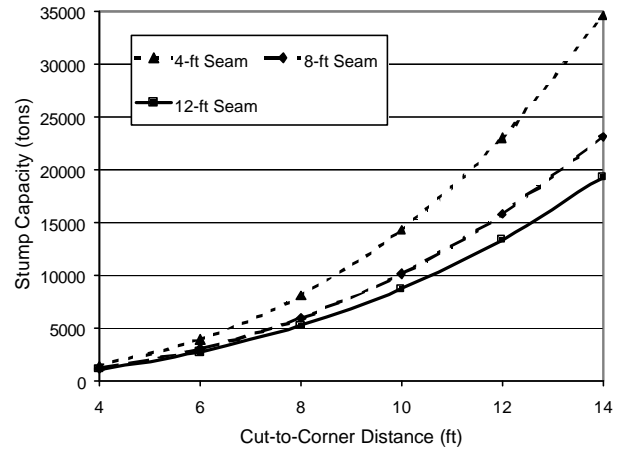

Figure 6. Load-bearing capacity of final stump for a variety of seam heights, assuming that $L_1 = L_2 = L$, $\phi_1 = \phi_2 = 75$ deg., and that the stump has not yielded. An SF of 2.5 is suggested to account for yielding of the stump.

When the cut-to-corner distances are not equal ($L_1 \neq L_2$), then a reasonable approximation is:

$$L_{eff} = \sqrt{L_1 * L_2}$$

This approximation is valid for $0.67 < L_1/L_2 < 1.5$. When the L_1/L_2 ratio is outside that range, one of the cuts is very close to the intersection and the performance of the stump has probably been compromised.

The next issue is the appropriate Stability Factor (SF), which is more precisely a capacity-to-load ratio. Unfortunately, there is not enough field data to determine an appropriate SF statistically. From the fatality reports, it appears that an SF of at least 2.5 might be appropriate. Two factors may contribute to the relatively high SF:

- *Final stumps usually consist of yielded coal.* The Mark-Bieniawski formula assumes that the pillar is initially intact, but the corners of a pillar are likely to yield as the pillar is extracted. The residual strength of the slender remnant stump is generally considerably less than the original strength (15).
- *Final stumps generally have w/h ratios in the 1-2 range.* The ARMPS data base contains few successful case histories from pillars so slender (16). Recent research suggests that traditional pillar strength formulas (like Mark-Bieniawski) may overestimate the strength of very slender pillars (17, 18).

Finally, the ability of the final stumps to resist gob caving should be evaluated. The SF of the stumps once they are isolated in the gob can be estimated by comparing their load-bearing capacity to the overburden load originally carried by the complete pillar. Figure 7 shows the SF as a function of depth for several common entry centers. Van der Merwe (11) suggests that stumps with $SF < 0.3$ will be too weak to inhibit caving. These final stumps meet his criterion once the depth of cover exceeds 100-150 ft.

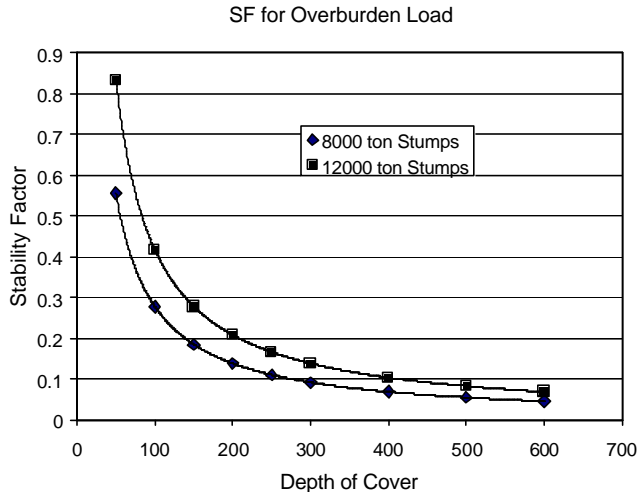

Figure 7. Capacity-to-load ratios for full overburden load of final stumps isolated in the gob, assuming stumps have not yielded.

COMPARISON WITH ROADWAY SUPPORTS

Since the purpose of final stumps is to serve as roof support, it is worthwhile to compare them to the other types of roadway support used in pillar recovery. Figure 6 shows that a typical 10 ft by 10 ft stump would have an estimated load-bearing capacity of about 10,000 tons if it had not yielded. For purposes of comparison, this value should be reduced by the SF of 2.5, giving an effective stump capacity of about 4,000 tons.

Wood posts have traditionally been used as roadway supports. A typical 6-in-diameter hardwood post can carry approximately 50 tons. If 12 such posts are used to support an active intersection, the total capacity is about 600 tons. The value of an effective final stump to supplement timber supports is obvious.

A single mobile roof support, on the other hand, is usually capable of carrying 600 tons. Four MRS are used in a typical pillar recovery operation. Their total capacity is, therefore, almost as great as a 10 ft final stump. The greater capacity, and better stiffness characteristics (13), of MRS compared to timbers is probably a big part of the excellent safety record they have established during the past decade.

CONCLUSIONS

Recent U.S. coal price increases will likely result in more room-and-pillar operations due to the relatively low capital investment and broad applicability of these systems. Undoubtedly, some of these operations will utilize pillar recovery methods to optimize resource recovery and/or mining productivity. As this segment of the industry expands, appropriate design and training will be imperative to avoid an associated increase in mining accidents. Lack of available skilled workers is a particular concern at the moment since the coal industry is facing a labor shortage in some areas (19, 20). As indicated in World Coal (21), "Pillar recovery requires a highly disciplined management

approach, with the need to carefully follow a detailed technical schedule to ensure that safety is maintained."

This paper has defined a "high extraction" approach to pillar recovery. Its basic principle is that a final stump is left in place to support the active intersection. The stump is more like a roof support than a pillar, which is why its size does not need to increase with depth. Guidelines have been provided to help size the final stump to carry the maximum anticipated rock load above the intersection. The stumps are also too small to seriously inhibit caving, at least at depths in excess of 150 ft. In general, the engineered final stumps require that no more than 5-10% of the original coal be left in place.

From a practical standpoint, the technique is simple to implement. Once the proper cut-to-corner distance has been selected, the foremen can use spray paint to mark the pillars in advance of mining. Explicit minimum dimensions and this type of visual marker should help maintain a minimum level of support for the adjacent intersection. However, these activities should be viewed as establishing a guideline; they should not deter miners from leaving larger stumps when necessary based on the conditions at hand. Ground conditions on the retreat section must be gauged to ensure that the minimum prescribed dimension is adequate.

Proper use of final stumps is just one element in safe pillar mining. Wherever possible, mobile roof supports should be used because of their superior support capacity. Other safety tips are listed on the "Best Practices" card available at the MSHA website (22).

During the past 5 years, the mining community seems to have largely succeeded in eliminating fatal roof falls associated with the mining of the last lift or final stump. It is hoped that the information presented in this paper can help to permanently make such incidents relics of the past.

REFERENCES

1. Mark, C., McCall, F.E. and Pappas, D.M. A Statistical Overview of Retreat Mining of Coal Pillars in the United States. Proceedings, New Technology for Ground Control in Retreat Mining, NIOSH Information Circular 9446, Pittsburgh, PA, 1997, pp. 2-16.
2. Stahl, R.W. Extracting Final Stump in Pillars and Pillar Lifts with Continuous Miners. BuMines RI 5631, 1960, 13 pp.
3. Montague, P.G. Pillar Recovery. Proceedings, American Mining Congress, Chicago, IL, Am. Min. Congr., Washington, DC, 1988, pp. 531-548.
4. U.S. Code of Federal Regulations (1998). Title 30—Mineral Resources: Chapter I—Mine Safety and Health Administration, Department of Labor; Subchapter O—Coal Mine Safety and Health; Part 75—Mandatory Safety Standards—Underground Coal Mines.
5. Federal Register, Vol. 53, No. 17, Wednesday, January 27, 1988, "Rules and Regulations," pp. 2354-2374.
6. Kauffman, P.W., Hawkins, S.A. and Thompson, R.R. Room and Pillar Retreat Mining, A Manual for the Coal Industry. U.S.

Department of the Interior, Bureau of Mines Information Circular 8849, 1981, 228 pp.

7. Kauffman, Peter W. and Steven A. Hawkins, "Operational Techniques for Room and Pillar Retreat Mining - Final Report," USBM Contract No. HO282021, March 1980, 76 pp.
8. Howe, Larry, International Sales Manager, J.H. Fletcher & Co., personal communication, 2001.
9. Galvin, J. M. Review of Overseas Pillar Extraction Techniques - South Africa. University of New South Wales, School of Mines, Strata Control for Coal Mine Design, Progress Report 4/93, 1993, 152 pp.
10. Beukes, J. S. Considerations in the Design and Layout of Pillar and Rib Pillar Extraction Panels. Proceedings SANGORM Symp: Advances in Rock Mechanics in Underground Coal Mining, 1989, pp. 105-111.
11. Van der Merwe, J.N. and Olivier, F.T. The Development of a Crush-Pillar System for High Extraction Coal Mining. Proceedings MASSIMIN 92, Johannesburg, SAIMM, 1992, pp. 403-407.
12. Mark C. Ground Control in South African Coal Mines—A U.S. Perspective. Proceedings, 18th International Conference on Ground Control in Mining. Morgantown, WV, 1999, pp. 186-193.
13. Chase, F. E., A. McComas, C. Mark, and C. D. Goble, Retreat Mining with Mobile Roof Supports. Proceedings, New Technology for Ground Control in Retreat Mining, NIOSH Information Circular 9446, Pittsburgh, PA, 1997, pp. 75-88.
14. Mark, C. Empirical Methods for Coal Pillar Design. Proceedings, 2nd International Conference on Coal Pillar Mechanics and Design, Vail, CO, NIOSH IC 9448, 1999, pp. 145-154.
15. Zipf, Jr. R.K. Using a Postfailure Stability Criterion in Pillar Design. Proceedings, 2nd International Conference on Coal Pillar Mechanics and Design, Vail, CO, NIOSH IC 9448, 1999, pp. 181-192.
16. Mark, C. and Chase, F.E. Analysis of Retreat Mining Pillar Stability. Proceedings, New Technology for Ground Control in Retreat Mining, NIOSH Information Circular 9446, Pittsburgh, PA, 1997, pp. 17-34.
17. Van der Merwe, J.N. New Strength Formula for Coal Pillars in South Africa. Proc. 2nd International Workshop on Coal Pillar Mechanics and Design, NIOSH IC 9448, 1999, pp. 163-172.
18. Madden, B.J. and Canbulat, I. Practical Design Considerations for Pillar Layouts in Coal Mines. Proc. SARES97, 1st Southern African Rock Engineering Symp., 1997, pp. 557-563.
19. Maimon, Alan, "Mines face labor shortage as young people shun coal, Industry's resurgence fuels demand for workers." The Courier-Journal, April 16, 2001.
20. McKay, Jim, "Miner shortage isn't happening locally—yet," Pittsburgh Post Gazette, " May 20, 2001.
21. Anonymous, "Room for a Rethink," World Coal, May 2000, pp 32-36.
22. Mine Safety and Health Administration (1999). Best Practices—Retreat Mining. Card available at website <http://www.msha.gov/S&HINFO/PROP/BESTPRAC/BP27.PDF>.