



USER'S GUIDE FOR  
8200 BUBBLER GAUGE  
(Installation and Operation)

Updated February 1998

Prepared by

Requirements and Engineering Branch  
Oceanographic Products and Services Division

National Ocean Service  
National Oceanic and Atmospheric Administration

## TABLE OF CONTENTS

BACKGROUND INFORMATION .....	Page 1
SYSTEM TRANSPORTATION .....	Page 2
Requirements .....	Page 2
SYSTEM INSTALLATION .....	Page 2
General .....	Page 2
System Tie-Down .....	Page 7
Connections .....	Page 7
1. Nitrogen supply .....	Page 9
2. Orifice connection .....	Page 9
3. Laptop connection .....	Page 9
4. Sutron 8200 connections .....	Page 9
5. Battery .....	Page 11
Start-Up .....	Page 11
Sutron 8200 Data Collection Platform .....	Page 11
Bubbler control unit .....	Page 12
8200 Gauges with GOES Capability .....	Page 12
SITE VISITS .....	Page 13
System Check .....	Page 13
Staff Observations: .....	Page 13
Direct Connection Data Retrieval: .....	Page 13
Battery Check .....	Page 13
Replace Desiccant Pack: .....	Page 13
Data Retrieval - Direct Connection .....	Page 14
Data Display - Direct Connection .....	Page 16
Transferring Data from Memory to a Ram Pack Cartridge .....	Page 17
APPENDIX A .....	Page 19
8200 DATA RECORDER SETUP .....	Page 19
APPENDIX B .....	Page 25
GUIDELINES FOR OPERATION AND DOCUMENTATION OF HYDRO GAGES WITH GOES CAPABILITY .....	Page 25
APPENDIX C .....	Page 27
SWAGELOK FITTING INSTRUCTION .....	Page 27

## BACKGROUND INFORMATION

The Sutron 8200 digital bubbler water level gauge was developed to provide a replacement system for the traditional analog chart-recording gauges. The gauges provide:

- ! Improved fittings, to assure more reliable and leak-free connections, allowing more operational life for the nitrogen cylinder.
- ! Completely electronic measurement and recording of pressure corresponding to the water level, to eliminate reliability problems caused by the chart drive, pen, and ink supply of the analog gauge.
- ! Retrieval of station data electronically. At present, there are three methods to retrieve data from the measurement system: (1) by connecting a lap-top computer directly to the gauge, (2) by remotely receiving the data via line-of-sight radio communications, or (3) by GOES.
- ! Direct entry of digital field data using diskettes into Oceanographic Products and Services Division, eliminating the manual digitization of analog chart records.

The development of the digitized bubbler gauge is due to culmination of cooperative efforts from Oceanographic Products and Services Division (OPSD) at Silver Spring, MD, field activities of the Coast Survey's Hydrographic Surveys Branch, and the Pacific Regional Office (PRO) of the Field Operations Branch (FOB) at Seattle, WA. Close interaction between all parties involved has resulted in measurement system modifications while taking into account suggestions and comments from the field user and maintaining the measurement performance and system compatibility required for data analysis.

General procedures on system installation and operation are summarized in this document. Each gauge enclosure contains a page of brief operating instructions summarized from this manual, setup parameters for the Sutron 8200 data collection platform, and a log sheet for recording field visits, operational problems, and/or services (e.g., battery replacement, etc.).

## SYSTEM TRANSPORTATION

### Requirements:

- ! Remove the system main battery.
- ! Secure loose components within the enclosure, tools, mounting brackets, desiccant bags, etc.
- ! Insert foam padding or bubble pack material if necessary to avoid damage during shipment.
- ! Open outlet valve on bubbler control unit prior to air shipping.
- ! Use shipping containers (cardboard boxes) and packing material to protect the enclosure and the system battery.

## SYSTEM INSTALLATION

### General

The digitized bubbler system is self-contained within a weatherproof polyester fiberglass reinforced enclosure. The system (refer to Figure 1) consists of a Sutron 8200 data collection platform (a); a bubbler control unit (b) containing pneumatic control elements along with the pressure sensor and temperature sensor (see block diagram in Figure 2); a battery (c); and interface connections for the nitrogen supply (f), the orifice tubing (e), the portable computer (h) and the line-of-sight radio antenna (g).

*Caution: The systems utilize a 15 psig pressure sensor; this limits the maximum height of water above the orifice to 34 feet. Greater water heights can cause calibration shifts; heights greater than 65 feet will cause permanent sensor damage.*

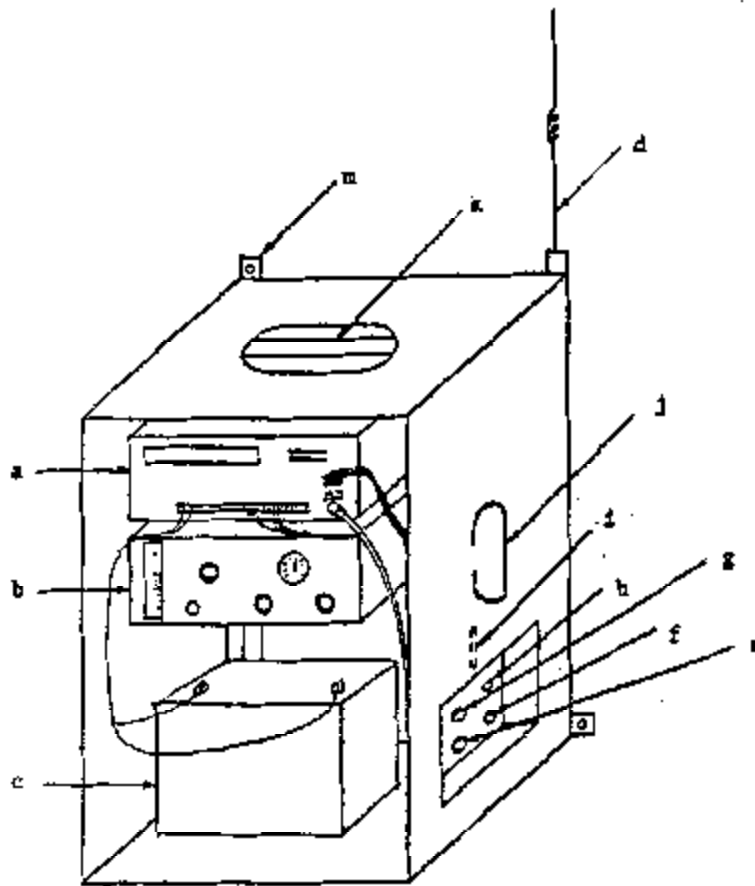

- a. Suttron 8200 Data Logger
- b. Bubbler control unit
- c. Battery
- d. Radio antenna
- e. Orifice connector
- f. Nitrogen supply connector
- g. Radio antenna connector
- h. Computer connector
- i. Atmospheric vent
- j. Side handle (for back anchoring)
- k. Top handle (for carrying and downward anchoring)
- m. Mounting brackets (see insert, for back anchoring)

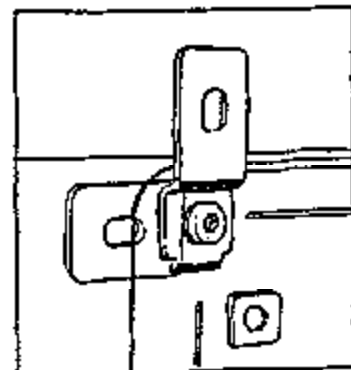

Wall mounting brackets are easily fixed in the vertical or horizontal position.

Figure 1. Gauge Components

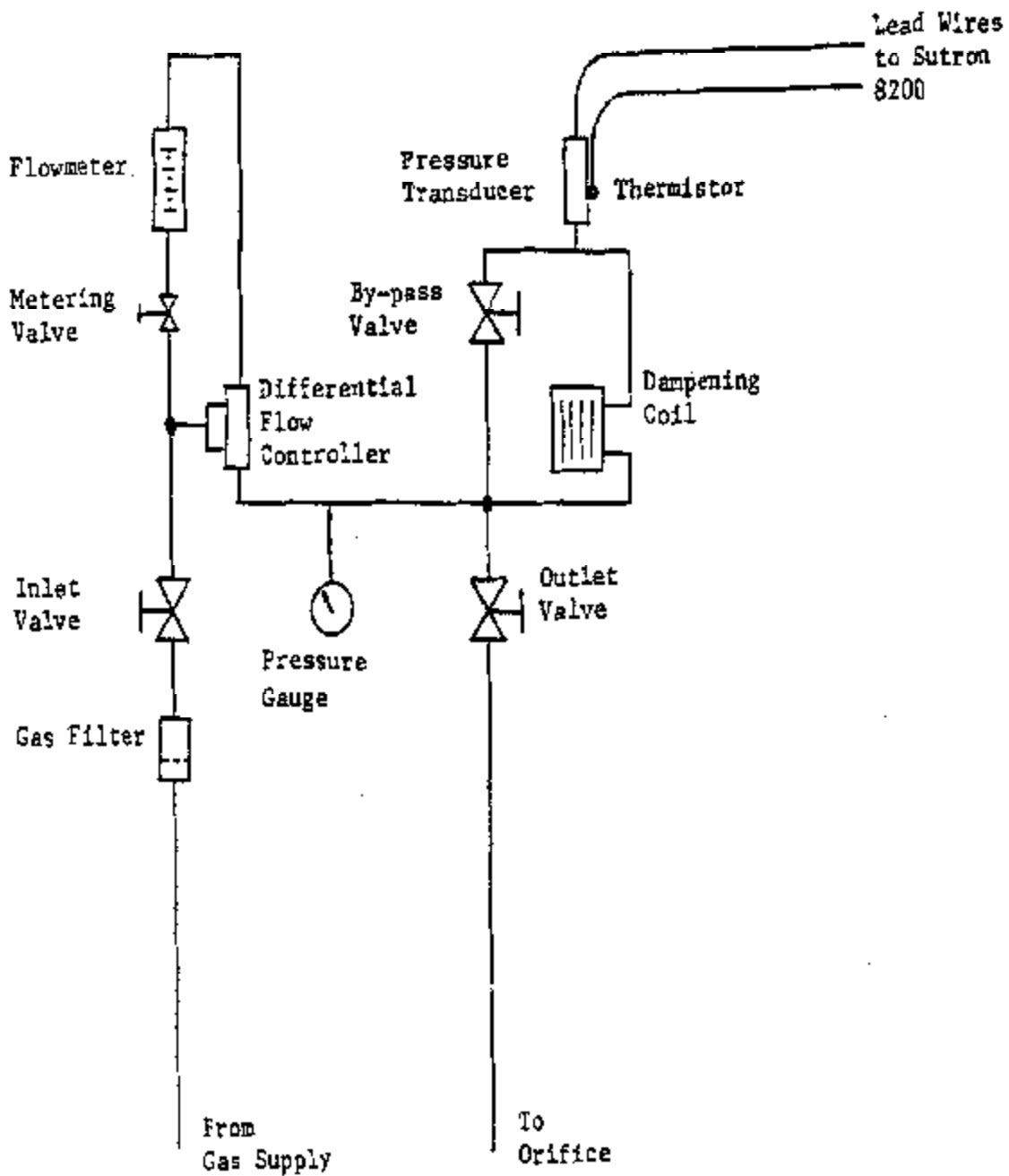

Figure 2. Components Inside the Bubbler Control Unit

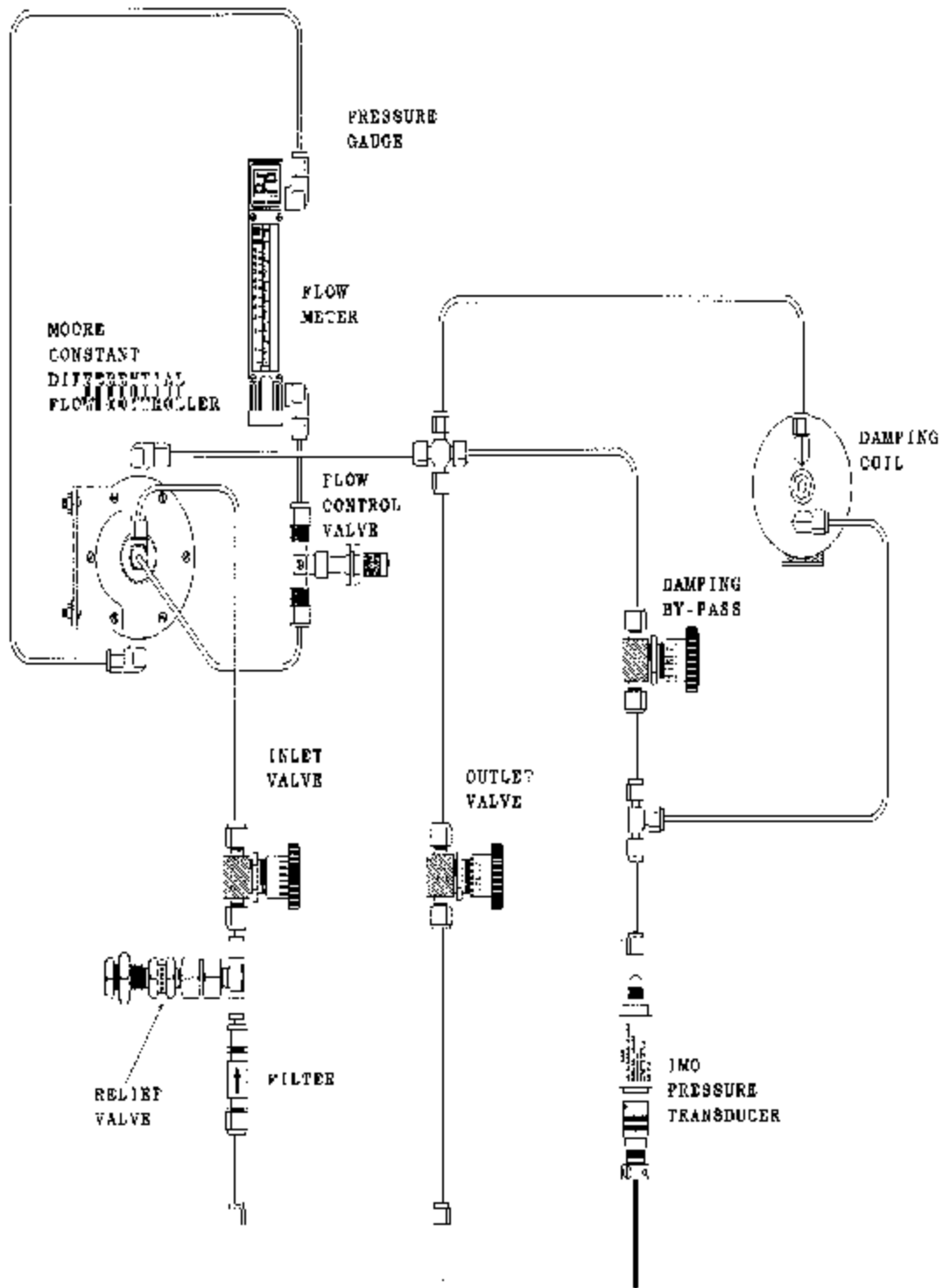

Figure 3. Schematic Diagram of Pneumatic Connections



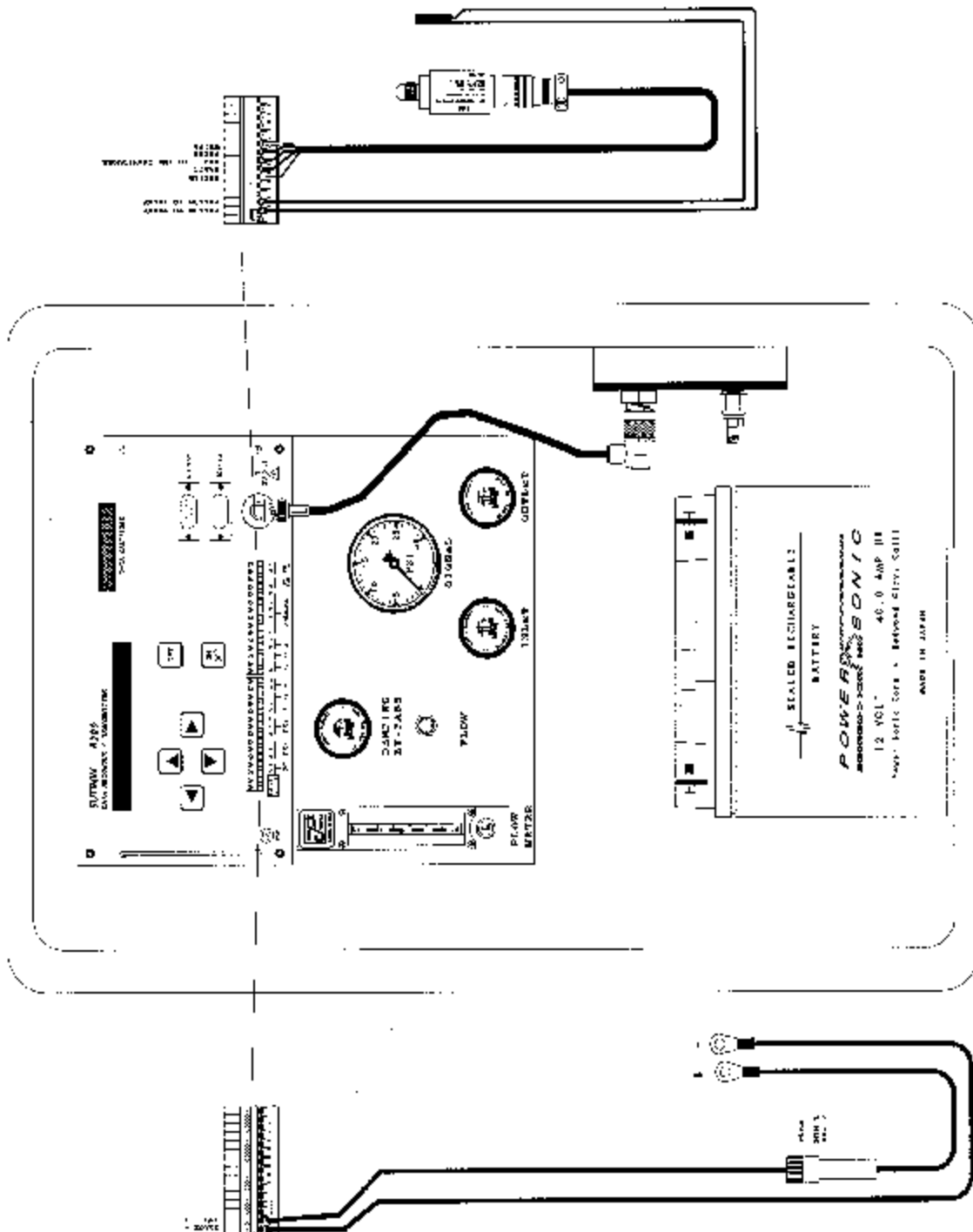

Figure 4. Sutron 8200 DCP Front Panel View

## System Tie-Down

Several attachment points are available on the bubbler system enclosure to provide for tie-down at the field site (refer to Figure 1):

- ! Metal brackets are provided with each system which can be bolted at each corner on the rear of the enclosure ("m" on Figure 1).
  
- ! A recessed carrying handle is located at the top of the enclosure; looping cables through this handle on each side would provide a four-point tie-down of the enclosure. If this method is selected, location of the front anchor points must be such that the tie-down cables do not interfere with the enclosure door ("k" on Figure 1).
  
- ! Handles have been added on each side of the enclosure which can also be used for tie-down purposes ("j" on Figure 1).

Figure 2 depicts the block diagram of the components inside the bubbler control unit.

## Connections

All external connections are located on the lower right side of the enclosure. The connections have been recessed to avoid possible entanglement during transportation to the deployment site. Connection of the digitized bubbler to the nitrogen supply and to the orifice line during deployment will require 7/16, 9/16, 11/16, and 1 inch open wrenches, an adjustable wrench, and a screwdriver.

The Swagelok fittings on the enclosure have retaining rings attached so that two wrenches are not required to attach the orifice and nitrogen source hoses. **Excessive torque in making these connections, however, must be avoided.** In Appendix C, a copy of instructions for Swagelok fittings is provided. Note the difference between new installation (1&1/4 turns past finger tight for 1/4 inch and larger tubing sizes) and re-tightening (only 1/4 turn past finger tight). **Tightening beyond these points will damage the mating surfaces, and result in a gas leak.**

If necessary, the polyethylene orifice tubing can be extended or repaired by joining pieces with Swagelok fittings. In order to avoid leaks, however, be sure that the tubing end is cut square and smooth, and that the tubing is free from scratches in the area that will be inserted in the fitting.

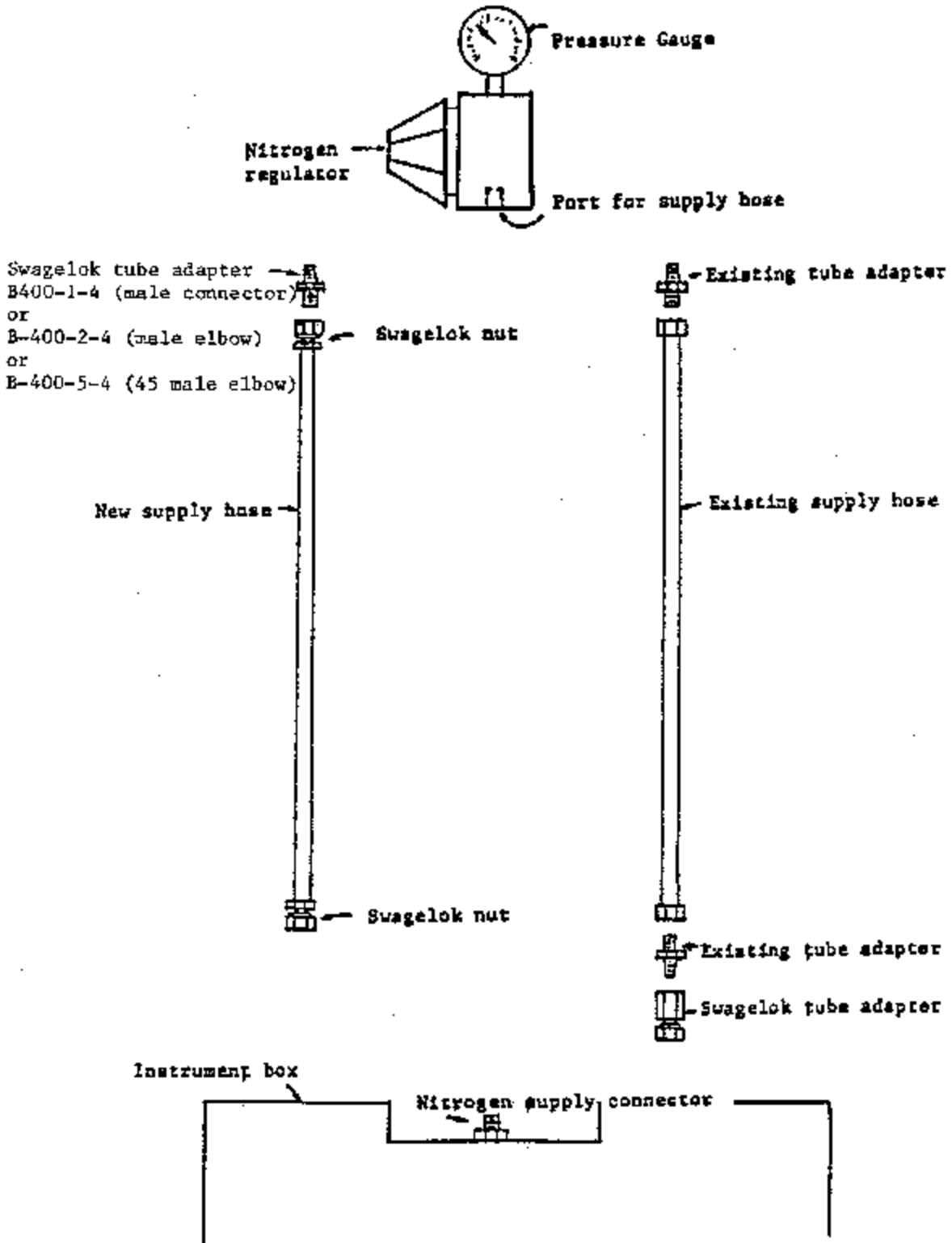

Figure 5. Gas Supply Hose Connection

### 1. Nitrogen supply (Figure 1, "f")

The nitrogen supply connection is a 1/4 inch stainless steel Swagelok fitting (see Figure 5). If the new gas supply hose (Swagelok fittings on both ends) is used, it will connect directly to the enclosure connection, but requires installation of the male pipe thread-to-Swagelok adapter (provided) in the nitrogen regulator. If a standard gas supply hose is used, a female pipe thread-to-Swagelok adapter (provided) must be connected to the hose prior to making the connection to the enclosure. When the Swagelok connection is made to the enclosure, **tighten only 1/4 turn past finger tight**, since this is a "re-tightening".

### 2. Orifice connection (Figure 1, "e")

The orifice connection is a 3/8 inch brass Swagelok fitting. Connection of the orifice tubing will be a new installation, requiring 1&1/4 turns past finger tight. It is preferable to make this "new installation" by using a spare 3/8 inch Swagelok fitting to swage the ferrules onto the bubbler tubing; connecting this pre-swaged tubing to the enclosure fitting would then only require 1/4 turn past finger tight.

### 3. Laptop connection (Figure 1, "h")

For the initial installation, it is not necessary to connect the laptop computer. To use the computer for data retrieval, the laptop computer connects to the gauge connector (shown "h" in figure 1) using the cable provided. The computer connection is to the "RS-232" connector located on the back of the computer.

### 4. Sutron 8200 connections (Figure 6)

The Sutron 8200 front panel connections are not changed during deployment; the following is provided as background information. As shown in Figure 6-b, the pressure sensor and thermistor leads are all connected to the right terminal block. A 29 K ohm resistor, part of the thermistor circuit, is also connected on this block. The rechargeable battery is connected to the left side of the left terminal block. The external computer connector ("h" in Figure 1) is brought to a 9 pin "D" type connector, which mates with the "RS-232" connector on the front panel. The "SDI-12" connector, and the data cartridge connector are not used in the present application. A small flat-blade screwdriver is required if it is necessary to re-tighten any of the leads on the terminal block.

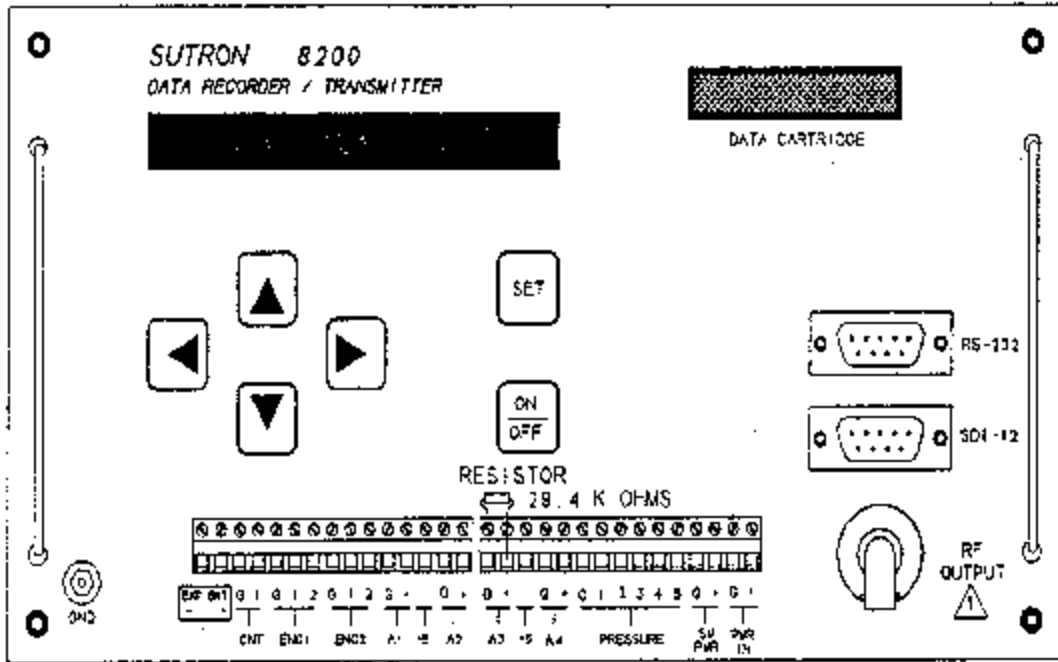

(A) FRONT PANEL

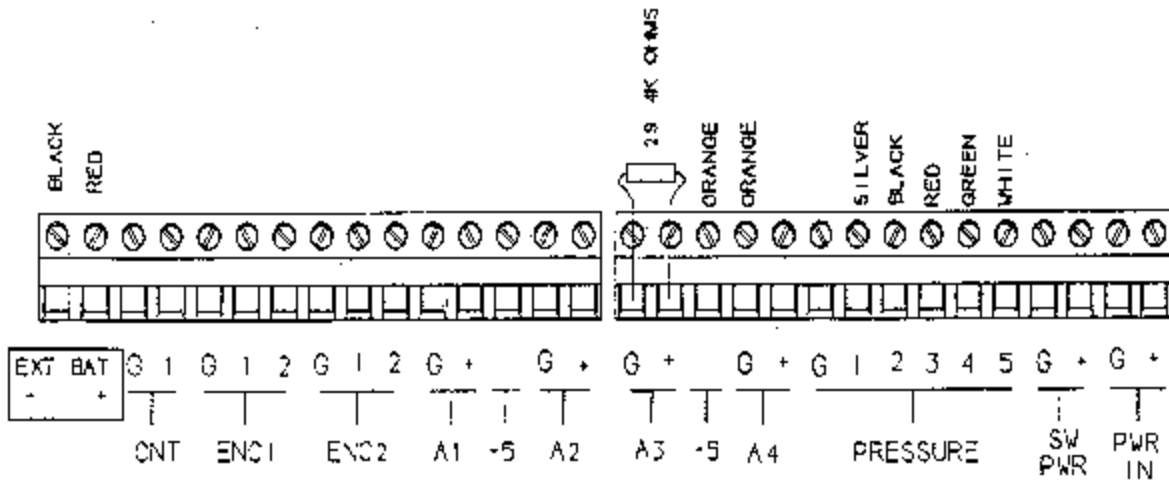

(B) 8200 Terminal Strip

Figure 6. Sutron 8200 Data Collection Platform Connections

## 5. Battery

The 12-volt 40 AHr rechargeable battery which powers the gauge will operate the gauge for approximately 45 days. If the battery voltage drops below 12.0 volts, it should be replaced with a freshly charged battery. The internal lithium RAM backup battery has a minimum life of one year, and should be replaced if the voltage is less than 2.8 volts.

### Start-Up

#### Sutron 8200 Data Collection Platform

The Sutron 8200 Data Collection Platform should be set up for measurement and recording prior to leaving the ship; thus the only steps required for the Sutron 8200 during system installation in field is to install and connect the battery and check the system date and time.

1. To connect the battery, remove the 8200 left front panel terminal strip by pulling it straight out from the panel. **DO NOT REMOVE THE WIRES FROM THIS TERMINAL STRIP.** Attach the black wire to the negative (-) terminal of the battery first. Then attach the red wire to the positive (+) battery terminal. After both battery leads are connected, plug the left terminal into the 8200 front panel. The 8200 display will be activated and the unit will perform a self-test then the display will turn off.
2. The date and time of the 8200 should be checked and reset if necessary. Press "ON/OFF" button to activate the display. Press the "DOWN" arrow twice to display the date. If the date needs to be changed, press the "SET" button then use the "UP", "DOWN", "LEFT", "RIGHT" arrows and the "SET" button to adjust the date. Once the date has been set, press the "DOWN" to display the time and adjust if needed using the same technique as for the date. The time should be referenced to UTC (Universal coordinated time or Greenwich Mean Time). UTC time is eight hours ahead of Pacific Standard Time and five hours ahead of Eastern Standard Time.
3. Verify the 8200 has recording enabled by pressing the "DOWN" arrow once after setting the time. The display should indicate "Recording ON". If recording is off, press "SET" to enable recording.

## Bubbler control unit

The following steps describe start-up procedures for the bubbler control unit; valve identifications correspond to labels on this unit.

1. Before opening the nitrogen bottle valve, be sure that the bubbler outlet valve is OPEN and the inlet valve is CLOSED. The dampening bypass valve should be open as it is no longer used. Also, to protect the pressure sensor and the mechanical pressure gauge (marked "SIGNAL") from over-pressure damage, the pressure regulator adjustment should be set to minimum pressure (turned fully counterclockwise).
2. Open nitrogen bottle valve; set regulator to 18 psi.
3. Open bubbler inlet valve and purge orifice line (a higher-than-normal flow rate may be used to accelerate purging).
4. Set to normal flow rate. The flow rate setting used depends on the tide range at the deployment site. For tide ranges of less than 4.5 m (15 ft), the flow rate should be set to 5 cc/minute. For tide ranges of 4.5 - 6 m (15 to 20 ft), set the flow rate to 6 to 7 cc/minute; and for 6 - 7.5 m (20 to 25 ft) tide ranges, use a flow rate of 7 to 9 cc/minute.
5. Verify that the mechanical gauge (SIGNAL) indicates a pressure approximately equal to the height of water above the bubbler orifice. To estimate the pressure assume 0.5 psi per 0.3 m (1 ft) of water, i.e. 3.7 m (12 ft) of water above the orifice should equal approximately 6 psi.
6. Place a desiccant bag in the enclosure on top of the system battery and close the enclosure.

## 8200 Gauges with GOES Capability

A Tiny Basic program NGFMT4.BAS needs to be uploaded in the 8200 if the GOES satellite capability would be used for data transmission. Appendix A provides information on the configuration of parameters required for the GOES Setup Menu and Appendix B provides information on operational and documentation requirements for the 8200 hydro gauges with GOES capability.

## SITE VISITS

### System Check

#### Staff Observations:

The digitized bubbler stores time referenced to UTC along with the pressure, temperature, and battery voltage measurements. Therefore, when making staff-gauge comparisons during periodic site visits, time should be recorded referenced to UTC along with the staff reading. Note that UTC time is eight hours ahead of Pacific Standard Time and five hours ahead of Eastern Standard Time. Data are recorded in the digitized bubbler at 0, 6, 12, etc. minutes past the hour; staff readings should be made as close as possible to these times. To view the recorded data from the 8200 use the "NEWEST" display option to provide the gauge measurements which correspond to the staff observations. *Do not use the "LIVE READINGS" from the 8200 for staff comparisons; this does not reflect the actual measurement of water level being recorded in the system.*

#### Direct Connection Data Retrieval:

Data from the internal storage of the Sutron 8200 should be uploaded to the external computer during each site visit. The following sections on "Data Retrieval" and "Data Display" describe the data upload and display procedures. In order to see "flat spots" or other indications of problems in the orifice/bubbler hose, the retrieved data should be displayed and checked on the computer **prior to leaving the station**. The figure 7 shows examples of several typical problems which might be encountered.

#### Battery Check

The 8200 external battery voltage should be checked using the 8200 display from the "VIEW DATA", "NEWEST READINGS", "BATTERY" selection from the menu structure. If the battery voltage is below 12 volts, it should be replaced with a freshly charged battery.

#### Replace Desiccant Pack:

The final step before leaving the station should be to replace the desiccant pack in the enclosure with a fresh pack. This should reduce the moisture which might accumulate in the enclosure due to condensation. The desiccant packs can be recycled by placing them in a 250EF oven for 12 hours and then placing the dried packs in sealed bags until they are installed.





(a) gas supply pressure set too low



(d) orifice is located in a tidal lagoon

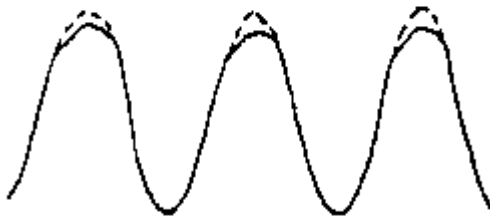

(b) insufficient gas purge rate,  
water run up the orifice tube

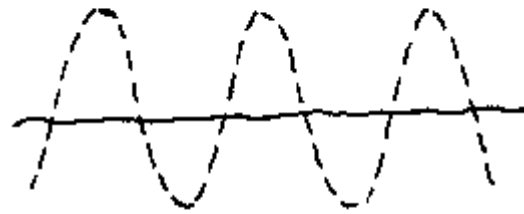

(e) severe leak in connections above water

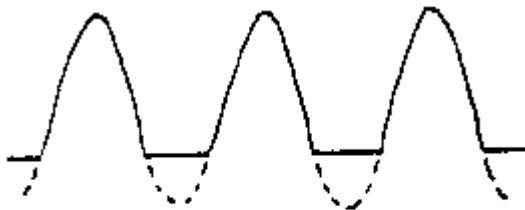

(c) orifice is above low tide levels

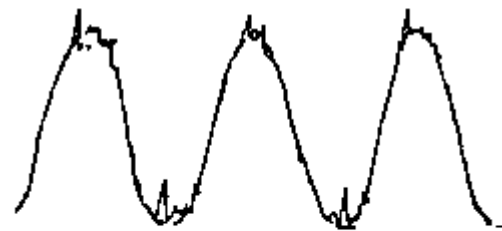

(g) orifice may be covered with sand

Figure 7. Cases of Improper Tidal Signals  
(dashed portion indicates correct tide)

#### Data Retrieval - Direct Connection

Water level data can be retrieved periodically from the digitized bubbler using a laptop computer and a Sutron program called "TW8200.EXE". This program provides for general communications between the laptop and the Sutron 8200; its data upload option creates a file on the laptop containing the retrieved data in a compressed binary format. This data can subsequently be displayed using another Sutron software package, "LOGPLOT.EXE", described in the next section.

! Turn on the laptop. When the laptop has completed booting, the HYDRO MENU will appear

on the screen. Select menu item "7" to run the program **TW8200.exe**. This program enables the laptop to communicate with the Sutron 8200.

- ! Connect the data cable to the upper right connector on the outside panel of the enclosure (shown "h" in Figure 1, and normally covered by a weather-tight cap). The other end of the data cable connects to the serial port on the computer (a 9 pin sub-D male on most laptops; a 25 pin sub-D male on older PC's, which will require a 9-pin male to 25 pin female adaptor). The computer serial port must be set for COM1, as the Sutron software will only communicate through COM1.
- ! Press <**F10**>. This will wake up the Sutron 8200 and display a menu screen on the laptop. The time will be updating every second. This is UTC time, which is eight hours ahead of Pacific Standard Time and five hours ahead of Eastern Standard Time.
- ! Press <**U**>. This will display the Upload menu. The date listed will be the first full day of data to be transferred. This can be changed by pressing <**D**> and then typing the month, the day and the 4-digit year, each followed by an <**Enter**>.
- ! Press <**S**>. This will start the upload of data to your computer. The word "DUMPING" will appear at the bottom of the screen. If "CHECKSUM ERROR" appears, you will have to press <**S**> again to restart the upload. When completed, it will say something like "COMPLETE 5K", where the "5K" is a measure of how much data was transferred.
- ! Press <**Esc**>. This returns to the initial Sutron 8200 menu.
- ! Press <**X**>. This deactivates the 8200 communications interface. Deactivation occurs automatically after 100 seconds if <**X**> is not pressed.
- ! Press <**F1**>. This exits the TW8200.EXE program.

The data upload option saves the retrieved data in a file on the laptop hard disk and assigns a file name based on the 8200 serial number combined with the start month and start day of the data dump, using a "log" extension. But, you can rename the data file later. Always name a log file with eight digit station and dcp# and three digit log extension. For more than one log file from a particular station, change the three digit extension as lg1, lg2, etc., as appropriate. For example, a data dump from a Sutron 8200 from station number 9414290 and dcp # 1 should be renamed as "94142901.log".

**The operator should graph the data on the laptop as soon as possible to assure that the desired data was collected and to verify the gauge is operation properly.** The following procedure describes the necessary steps to graph the data collected from a direct connect data download.

### Data Display - Direct Connection

Data uploaded to a disk file can be displayed in the form of a screen plot with "LOGPLOT.EXE", also written by Sutron. This program reads the compressed binary data file created by "TW8200.EXE", allows selection of parameters to be displayed, and allows selection of scaling on the vertical axis. The following steps demonstrate how to generate the screen plot on the laptop computer.

- ! Select option "A" from the HYDRO MENU. The program will prompt for the data file to be graphed such as "94142901" <Enter>, where "94142901" is the name of the data file to be plotted. It is not necessary to include the file extension (.log). The screen will display the measured parameters available to be plotted:

```
>ANALOG
WATERLEVEL
OUTLIERS
DEVIATION
BATTERY
```

- ! Press <cursor down> <Enter>. This selects water level data to be plotted.
- ! Press <P> to initiate plotting.
- ! The program will request a y-axis minimum value. Type **0** <Enter>.
- ! The program will next request a y-axis maximum value. Type **50** <Enter>.
- ! The program will display a graph of the tide in meters, with the horizontal axis being date and time. With this software you can change the time scale which is plotted by typing "1" for one day, "2" for two days, ..., "W" for a week and "M" for a month of data. The tide height scale can be change manually or, if the plot is re-initiated, the software will automatically select a vertical scale based on the data range:
  - ! Press <Enter>. This will bring back the parameter selection screen.
  - ! Press <P>.

- ! The program will request a minimum value (it will display the actual minimum found in the data file). Press <Enter>.
- ! The program will request a maximum value (it will display the actual maximum found in the data file). Press <Enter>.
- ! The program will display a graph with an expanded vertical scale, depending on the actual minimum and maximum values in the data file.
- ! To exit the "LOGPLOT" program, press <Esc>.

The screen plot can be printed on a printer. To do this, the DOS program "GRAPHICS.COM" must be run before running the "LOGPLOT" software. This program has been included in the laptop startup program (autoexec.bat). While the plot is displayed,

- ! Press <print\_screen>. On some computers, you must press both the <Shift> and the <print\_screen> keys simultaneously; on others, pressing <print\_screen> alone is adequate.

Two other Sutron-authored programs which can be run from the DOS prompt that may be helpful in examining the data are:

LOGPRN.EXE converts the compressed binary ".LOG" data files into ASCII files (".PRN" extension) to allow import into a spreadsheet program. This program has been included in the HYDRO MENU, selection "B". When the program is run, the file name should be followed with " /z/j", example ("94142901 /z/j"). These options will insert zeros for non-recorded data and display the Julian day numbers.

LOGSTAT.EXE reads the compressed binary (".LOG") files and displays daily statistics (maximum, minimum, mean, and number of data points) on the computer screen.

### Transferring Data from Memory to a Ram Pack Cartridge

The data from the 8200 can be quickly retrieved using a RAM pack to temporarily hold the data so that it can be read later with a RAM pack reader connected to a computer. The advantage of this method is that it is fast, easy and does not require additional equipment such as a laptop computer.

To dump to the RAM pack, turn on the 8200 by pressing the "ON/OFF" button on the front panel. Next press the "DOWN" arrow until "DUMP DATA" is displayed. Press the "RIGHT" arrow and the

display will now show the start date for the data download. This can be changed by pressing the "SET" button and using the "UP" and "DOWN" arrows to change each parameter of the start date.

Once the start date is correct, press the "DOWN" arrow to display the word "Cartridge". Insert a RAM pack into the slot located on the top right of the 8200 front panel. The cartridge must be inserted, Sutron label up. Press "SET" to start the dump to the data cartridge and when the display returns to "Cartridge" the download is complete. This process takes only a few seconds. Once completed, remove the cartridge and press the "LEFT" arrow to return to the start up display "Sutron 8200 v3.2". Press the "DOWN" arrow several times until "VIEW DATA" is displayed. Press the "RIGHT" arrow once then the "DOWN" arrow twice to display "NEWEST DATA". By using a similar procedure, "RIGHT" arrow and "UP" and "DOWN" arrows you will be able to view the most recent data which was logged for each sensor.

After verifying that the sensors are operating properly, press the "LEFT" arrow a couple times then "DOWN" to the "INSPECT SYSTEM" menu. Next press the "RIGHT" arrow and the "DOWN" arrow twice to the "Display Status". Now press "SET" and the system status will scroll across the 8200 display. Verify that there are no system errors and that the GOES transmitter has been enabled. In addition to the status of the GOES, the display will indicate the times of the last and next GOES transmission. The status display can be activated again if you were not able to read all the information as it scrolled across the screen. If all looks ok, press the "ON/OFF" to shut off the 8200 display.

## APPENDIX A

### 8200 DATA RECORDER SETUP

#### MAIN MENU

N - Unit Name	Station & DCP#
D - Set Date	02/18/1998
T - Set Time	16:46:24
R - Recording Status	ON/TX
C - Clear Alarm	NORMAL
V - View Sensor Data	
S - System Setup Options	
U - Upload/Download Data	
E - EEROM Setup Options	
P - Protocol Setup Options	
I - Inspect System	
A - Application Menu	
X - Exit	

Choose:

#### System Setup Menu

- M - Measurement Schedules
- E - Enable Sensors
- C - Configure Sensors
- A - Alarm Options
- B - Basic Program
- P - Change Password
- S - Save Setup
- R - Restore Setup
- I - Init Setup
- Z - Zero Counters

Choose:

Measurement Schedules

M - Measurement Interval	00:06:00
I - Sampling Interval	00:00:01
T - Measurement Time	00:07:40
S - Sampling Time	00:04:30
P - Switched Power Time	00:04:30
A - Samples to Average	181
L - Measurements per Log	1
B - Basic Run Interval	00:06:00
R - Basic Run Time	24:00:00
O - Switched Power Options	OFF

Choose:

CONFIGURE SENSORS

Choose [U]p [D]n [M]es [L]og [A]vg [I]nt [V]al [S]lo [O]fs [E]lev [R]d:

Active Sensors

- >Airtemp
- Waterlevel
- Outliers
- Deviation
- Battery

Configuration

M - Measure	ON
L - Log	ON
A - Average	OFF
I - Interval	00:00:00

Calibration

V - Value	Current Value
S - Slope	1.0000
O - Offset	0.000
E - Elevation	0
R - Right Digits	2

Active Sensors

- Airtemp
- >Waterlevel
- Outliers
- Deviation
- Battery

Configuration	
M - Measure	OFF
L - Log	ON
A - Average	ON
I - Interval	00:00:00
Calibration	
V - Value	Current value
S - Slope	????.????
O - Offset	??.???
E - Elevation	0
R - Right Digits	3

Active Sensors

- Airtemp
- Waterlevel
- >Outliers
- Deviation
- Battery

Configuration	
M - Measure	OFF
L - Log	ON
A - Average	OFF
I - Interval	00:00:00
Calibration	
V - Value	Current value
S - Slope	1.0000
O - Offset	00.000
E - Elevation	0
R - Right Digits	0



Active Sensors  
Airtemp  
Waterlevel  
Outliers  
>Deviation  
Battery

Configuration	
M - Measure	OFF
L - Log	ON
A - Average	OFF
I - Interval	00:00:00
Calibration	
V - Value	Current value
S - Slope	1.0000
O - Offset	00.000
E - Elevation	0
R - Right Digits	3

Active Sensors  
Airtemp  
Waterlevel  
Outliers  
Deviation  
>Battery

Configuration	
M - Measure	ON
L - Log	ON
A - Average	OFF
I - Interval	00:00:00
Calibration	
V - Value	Current value
S - Slope	1.0000
O - Offset	00.000
E - Elevation	0
R - Right Digits	2

NOTE:

1. The "Current value" is an instantaneous sensor reading.

GOES Setup Menu		
T - Transmit Mode		Basic
S - Satellite ID	_____	
I - International		OFF
F - Format	(ST)	BINARY
C - Carrier	(ST)	SHORT
1 - Channel	(ST)	_____
2 - TX Time	(ST)	_____
3 - TX Rate	(ST)	03:00:00
4 - # Data Items/TX	(ST)	31
5 - Data Time	(ST)	00:00:00
6 - Data Interval	(ST)	00:06:00
R - Random Setup Menu		

NOTE:

1. The satellite id, channel #, and TX time information is on a green tag inside each gauge.

EEROM SETUP:

EEROM Setup Menu		
M - Serial Port Mode		USER
U - User Baud Rate		9600
T - Transfer Baud Rate		9600
S - SDI-12 Baud Rate		1200
E - Entry Key Required		OFF
D - Log Dump Mode		ALL-BIN
L - User Time Limit (sec)		100
O - Power on Delay (10*ms)		1
P - Pressure Delay (10*ms)		5
A - Analog Delay (10*ms)		5
K - Auto Startup Keys		
1 - Time Format		24 HOUR
2 - Date Format		MDY
B - Basic Prog Sixe (KB)		6
G - Amplifier Gain	_____	

NOTE:

1. The AMP gain info will be different for each unit, see additional slope/offset sheet provided.

## 8200 GOES SET-UPS

*AQTEMP1	counter2	windspeed2	*DEVIATION	datapack
*AQTEMP2	counter3	windspeed3	serial	excitation
*AIRTEMP	counter4	windspeed4	*battery	ground
*ANALOG1	frequency	*WINDDIR	shaft8500	reference
*BARO	*FREQ1	winddir2	*#BUF	amplifier
encoder1	frequency2	winddir3	org100	optional
encoder2	frequency3	*WTRTEMP	org700	goesclock
counter	frequency4	*WATERLEVEL	timer1	sdI2_1
counter1	*WINDSPD	*OUTLIERS	timer2	sdI1_1
*AQAVG	*AQSTD	*AQOUT	sdI6_1	sdI8_1

\* Enable the marked sensors.

## ALARM SENSOR OPTIONS

This will be the same for the sensors being transmitted over GOES. All other sensors enabled in sensor select will have the alarm options enabled to OFF.

Waterlevel  
 Airtemp \*Group0000  
 Outliers  
 Deviation

Alarm Options	
E - Enable	GOES
G - Groups	0100
C - Control	OFF
1 - High Alarm	OFF
2 - Low Alarm	OFF
3 - ROC Alarm	OFF
Alarm Limits	
H - High Limit	OFF
L - Low Limit	OFF
R - ROC Limit	OFF
B - Deadband	OFF



## APPENDIX B

### GUIDELINES FOR OPERATION AND DOCUMENTATION OF HYDRO GAGES WITH GOES CAPABILITY

The following guidelines shall be followed by hydrographic field parties regarding the operation and documentation of portable 8200A digital and digibub gages transmitting data using GOES. It is critical that these lines of communication be followed and that time allowances be considered in the field planning. Lack of advance notification may cause a delay in the permission to start transmissions, or the possible loss of data during the first few days of data collection.

1. Assignment of platform IDs and station numbers for tide station installations:

In general, unless the platform IDs have been preassigned to gauge units as done for the West Coast hydro operations, request in writing<sup>1</sup> by fax or via telephone, the platform IDs for each gauge scheduled to collect and transmit data by GOES at least one month prior to the start of the hydro survey. The request must include the station number, name, latitude, and longitude of each upcoming installation. If an exact station location is unknown and no station number has been assigned, provide the name of the general area and an approximate latitude and longitude if site reconnaissance has been performed. The request will be forwarded for platform ID assignment and Radio Frequency Authorization; a response is usually made within two weeks, at which time the installation log sheets (copy attached) will be faxed to the appropriate field party.

In cases where platform IDs have been preassigned to data collection platforms (DCPs), such as Sutron 8200 hydro gauges, the field party needs to provide information such as location and the appropriate gauge number (and the corresponding platform ID). For new station installations, request the assignment of station numbers as stated above.

2. Record and documentation requirements:

Prior to the start of data transmission at a site, confirm the gage platform ID, related transmission parameters such as channel and transmit time, station installation date, gage and all sensor serial numbers, by faxing the Next Generation Water Level Measurement System (NGWLMS) Site Report and Field Tide Note to headquarters<sup>1</sup>. This facilitates the configuration of that station in the Data Processing and Analysis Subsystem (DPAS) prior to the receipt of the first data transmission before the beginning of the hydro operations.

**NOTE: failure to provide advance confirmation as stated in Section 2 above may result in the loss of transmitted data until the station is configured in DPAS.**

3. Removal of tide stations and reinstallation of gauges:

Always contact headquarters and inform in advance the date of removal of a hydro gauge. Generally, the data collection efforts are monitored and if a platform transmission ceases from a particular site, then it would be difficult to judge whether the loss of transmission is caused by malfunction of a gauge or actual removal.

If an installed gauge at an original site is to be removed and reinstalled at a different site, then the following additional information shall be provided at least one month prior to the reinstallation of that gauge at the new site:

- Station number, name, and expected date of removal of the existing gauge.
- Station number, name, latitude, longitude, and expected date of installation of the gauge at the new location. If the new location is uncertain, but within a specified area, provide an estimated latitude and longitude to the nearest minute.

If deemed necessary, a new installation log sheet will be issued, as appropriate, with the same GOES ID and different related parameters, such as pointing angle of the antenna. The new log sheet will then be faxed to the field party requesting the information. Otherwise, all other information remains the same except for the station number, name, latitude and longitude.

CAUTION: transmission of data by GOES requires advance planning and absolute certainty regarding the documentation requirements. Please follow these guidelines and all should go well. If there are any questions or help needed, please contact the following personnel.

**<sup>1</sup> COMMUNICATIONS CONTACTS**

EAST COAST HYDRO PARTIES

Thomas F. Landon  
Tel: 301-713-2897x191  
Fax: 301-713-4465 or 4435

WEST COAST HYDRO PARTIES

Manoj R. Samant  
Tel: 301-713-2897x190  
Fax: 301-713-4465 or 4435

Common address:

NOAA/NOS - N/CS41  
1305 East-West Highway SSMC4,

Sta. 6432 (Tom) or Sta. 6350 (Manoj)  
Silver Spring, MD 20910-3281



**APPENDIX C**

**SWAGELOK FITTING INSTRUCTION**