

Hydrogen Sprint – Wheels, Axles & Bearings

Student Objective

The student

- given a scenario of a design with wheels, will be able to predict how the design will function as variables to the wheels, axles and bearings are manipulated.
- will be able to explain how friction, traction, bearings, lubrication, weight distribution and wheel alignment affect the performance of things with wheels.
- will be able to explain the difference between simple bearings, ball bearings and bushings and explain why they are used

Key Words

alignment
axle
ball bearing
bearing
bushing
friction
thrust bearing
traction
weight distribution

Time:

1.5 - 2 hours for investigation

Materials

- Various hobby and toy wheels, recycled items that wheels can be made from such as cds, small cans, lids, spools, etc. and pieces of material that wheels can be cut from such as: plastic, wood, balsa, and wood dowels
- compass
- X-acto™ knives
- safety goggles
- tin snips, electric drill and other hand tools as necessary to cut the materials above
- pieces of various axle and bearing and chassis materials (shape unimportant) such as wood, plastic, metals, styrofoam, polyflute. Include balsa sheet and some steel objects
- ruler
- plank that can be lifted at one end
- soup can (1 per group)
- marbles (approx. 12 per group)
- plasticine clay
- pencils
- lid that fits over top of soup can—not tight (1 per group)
- large textbook
- coins (15 per group)

Internet Sites

http://www.exploratorium.edu/snacks/downhill_race.html

Supplemental experiment/demonstration from the Exploratorium Teacher Institute demonstrating how the distribution of mass in a cylinder (wheel) affects how quickly an object accelerates.

<http://www.rahul.net/mcgrew/derby/speed.html>

Site written by an engineer/physicist on making a derby car faster. Basic principles of design and physics may be helpful in the H2S design process.

Procedure

1. Students should work in their sprint teams (2 - 6 students).
2. Lead a classroom discussion/review of key words and terms, asking them what they already know about friction, traction, wheel alignment, weight distribution and bearings as it relates to automobiles, bicycles and skateboards. Some key points that you might want to make sure that they cover are:
 - friction wastes energy and slows down a vehicle
 - traction is ‘good’ friction, as in keeping a tire from slipping on the road.
 - wheels that are not aligned will affect performance
3. Pass out, or have in stations the materials that all the groups will be using – soup cans, marbles, clay, lids, rulers, plank. Students can pick their materials for the wheel and axle/bushing investigations from a box of miscellaneous materials in the classroom.
4. Students should complete the exercises in their Laboratory Manual in groups. Encourage brainstorming of the scenarios in the exercises; teams should see how many solutions they can come up with.
5. Give teams time to discuss how they plan to incorporate these findings in their vehicle design.
6. Teams should sketch their ideas in their team journals.
7. Teams should then continue constructing their vehicles.

Hydrogen Sprint – Wheels, Axles & Bearings

			.1	.2	.3	.4	.5	.6	.7	.8
The Nature of Science	Standard 1	SC.H.1.4-	X							
	Standard 2	SC.H.2.4-								
	Standard 3	SC.H.3.4	X					X		
Mathematics: MA.B.1.4.1										

Benchmark SC.H.1.4.1 - The students knows that investigations are conducted to explore new phenomena, to check on previous results, to test how well a theory predicts, and to compare different theories.

Benchmark SC.H.3.4.1 - The students knows that performance testing is often conducted using small-scale models, computer simulations, or analogous systems to reduce the chance of system failure.

Benchmark SC.H.3.4.6 - The student knows that scientific knowledge is used by those who engage in design and technology to solve practical problems, taking human values and limitations into account.

Benchmark MA.B.1.4.1 - The students uses concrete and graphic models to derive formulas for finding perimeter, area, surface area, circumference, and volume of the- and three-dimensional shapes, including rectangular solids, cylinders, cones, and pyramids.

Hydrogen Sprint – Wheels, Axles & Bearings

alignment – the position of parts in relation to each other, such as perpendicular or parallel. In wheel alignment, the proper alignment is rolling directly forward.

axle – a shaft that a wheel or a pair of wheels revolve on

ball bearing – a type of bearing that uses small balls to reduce friction.

bearing – the interface between two parts. In your H₂S vehicle we will be referring to the interface between the axle and the chassis. This can be as simple as a hole, or as complex as bushings or ball bearings.

bushing – a smooth sleeve that gives the axle a low friction surface

friction – the resisting force between two materials that are in contact and moving past each other. Friction usually results in some energy being changed to heat.

thrust bearing – in your H₂S vehicle it is a device that keeps the axle from falling out of the chassis. It can also keep the wheels from rubbing onto the side of the car

traction – friction that keeps two things from slipping; for example tire traction refers to how well the tire keeps from slipping on the road surface.

weight distribution – the arrangement of the weight in an object.

Hydrogen Sprint – Wheels, Axles & Bearings

The purpose of the wheels is to move your vehicle as efficiently and quickly as possible. If you have not yet decided what kind of wheels you want to use on your vehicle, and how you are going to attach your wheels to your chassis, this investigation into some of the principals involved in the wheels, axles and bearings of your vehicle should give your team a place to start or a way to test your ideas.

Part 1 – Wheels

1. Make a list of the different wheels that you could use. Include materials that you could make a wheel from as well as common items that could be turned into a wheel.

Weight of Material

2. Choose six materials that you would like to investigate for wheels. These could be purchased wheels, wheels from toys, or raw materials that you could use to cut out wheels. Put the name of the material (for example – small lego wheel, or balsa wood) in the top row. Complete the chart to compare the materials.

Material						
Weight						
Volume						
Grams per cm²						

3. Why would the weight of the wheel be important?

4. Imagine that another team has decided to use a balsa wood wheel 3" in diameter. Without changing the diameter of the wheel, can you think of some ways that they could reduce the weight of the wheel?

5. Traction is important with any vehicle. Traction is the 'gripping' of the road by the wheels, and it is traction that enables the wheels to go forward rather than just spinning. Imagine that your group finds during the testing stage of your vehicle that your cd wheels don't have enough traction. What could you add to your wheels to increase their traction on the racing surface?

6. Weight distribution can also have an effect on traction. Imagine your group's car from question 6 is still slipping even with the addition of 'tires'. One of your team members suggests that the car needs to be firmer on the ground. Remembering the weight distribution experiment from the previous chassis investigation, how could you increase the traction of your vehicle?

Part 2 – Axles

7. Axles need to be stiff, strong and very straight. Make a list of the different axles that your team could use. Include materials that you could make an axle from, common items that could be turned into an axle (for example a bicycle spoke or an umbrella rib), and materials that can be purchased and used for your axles.

Part 3 – Bearings

Friction is very undesirable in the wheel axle. The axle must be supported and attached to the chassis, but it still must be able to spin as freely as possible. Components which allow the relative motion of the two parts are called bearings. A plain bearing can be as simple as an axle running through a hole, or it could be a bushing. A bushing is a smooth sleeve that gives the axle a low friction surface to spin in. The illustration below shows some different bearing designs.

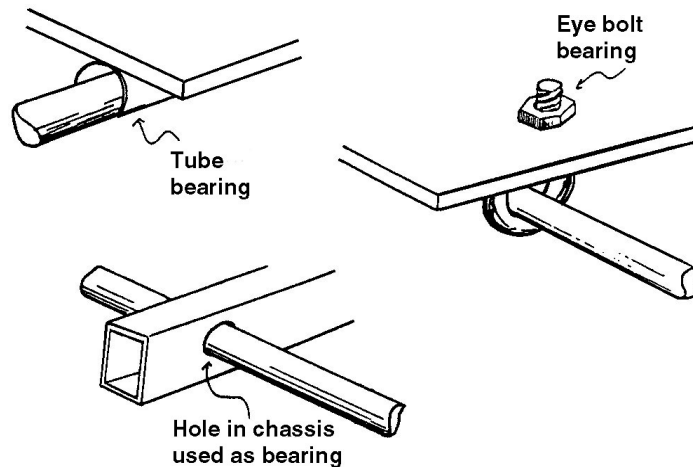

Bearing Materials

To choose the best materials for the axles and bearings you can test the friction between different types of materials. For instance, you can test the friction between metal (axle) and wood (bearing/chassis). The best bearing and axle combination will have the least amount of friction, allowing the axle to spin freely. This test will determine at what angle a sample piece of material overcomes the forces of gravity and friction and starts to slide. This test works because the weight of the object is not important. A steel paper clip will start sliding at the same angle as a heavy steel object.

- Pick three sets of materials (axle/bearing) that you would like to test and put them in the top two rows of the chart below. Balsa and steel have already been picked for you. Taking one set of materials at a time, stack one on top of the other at one end of the plank. Slowly tilt the plank by raising the end that the materials are on, until the top object starts to slide just a little. Measure the height that the plank was raised and put that number in the chart below.

Bearing Material	<i>Balsa</i>			
Axle Material	<i>Steel</i>			
Height plank was raised				

- Which combination of materials started to slide first (at the lowest plank angle)? Does this mean that those materials have more or less friction between them?

10. What would you expect to happen if you coated these two pieces with a little bit of oil or powdered graphite?

Ball Bearings

A common type of bearing is the ball bearing. The following investigation demonstrates how a ball bearing works.

11. Make sure you have the following materials for the investigation: can, lid, pencil, clay, marbles (approximately 12). Attach 1" balls of clay to both ends of a pencil. Using another 1" ball of clay, securely attach the pencil by its midpoint to the center of the lid. The two ends of the pencil should extend like paddles from the top of the lid. Place the lid on top of the soup can. Spin the lid. Does the lid seem to spin easy or hard?

Take the lid off the can and put about 12 marbles on top. Place the lid back on top of the can. Spin the lid. Does the lid spin easier? Why do you think this is so?

Part 4 – Thrust bearings

The thrust bearing keeps the axle from falling out of the side of the car and can keep the wheel from rubbing on the body of the car.

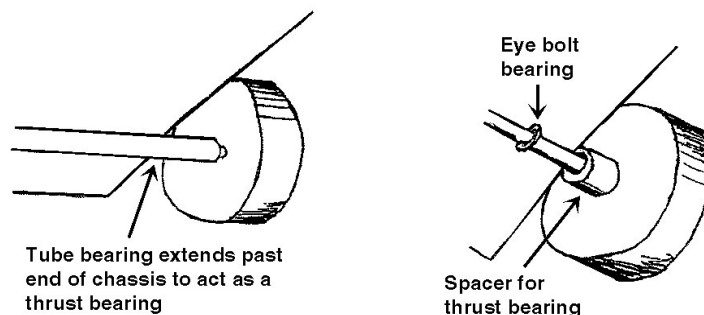

12. If there is something around the axles that let the center portion of the wheel touch first, the drag will be lower than if the outer part of the wheel touches. To demonstrate this,

put a large heavy textbook flat on the table. Rotate it slowly back and forth to get a feel for how hard it is to turn. Next, put a stack of three coins on the table under the center of the book and balance the book on the coins. Make sure that the corners of the book don't touch the table and try rotating the book slowly back and forth again. Was it easier or harder to turn the book with the coins underneath?

Next, add a stack of coins under each corner and rotate the book slowly back and forth to get a feel for how hard it is to turn with a stack also on each corner. Then move the outer stacks of coins towards the center stack a little bit at a time, and test after each move (For example, try placing the coins approximately 4" apart, then 3", 2" and finally 1" apart.) Does it get easier or harder as the coins move toward the center?

Discussion and Design

With your group, discuss how you might use the findings from your investigations to help you design your Sprint vehicle. Remember, there are a lot of variables in the design of your vehicle, especially when you are designing moving parts! Your challenge here is to reduce friction on the vehicle, have enough traction on the surface, and do it with the least amount of weight as possible! Here are some points to also consider:

- A narrow wheel has a smaller 'footprint' than a wider wheel of the same diameter. This means less friction, but will you still have enough traction with the narrower wheel?
- Poor wheel alignment can waste a lot of energy. When the wheels on your vehicle are not lined up properly, some of the wheels must slide sideways, or steer your vehicle off to the side which can make your vehicle crash or rub into the lane sides. Make sure you double check your wheel alignment. When the car is not in a race lane, does it still go straight?
- Tires may not be necessary on your vehicle. If they are, narrow and firm tires will keep the rolling resistance (friction) low.
- The faster the axle rotates in the bearing, the more friction and drag it will have. A larger wheel will allow the axle to rotate more slowly (if the car is to go at the same speed), and will waste less power in the bearings.
- Sources of bearings could be brass or plastic tubing (drinking straws), parts from videocassettes, or screw eyes/eyebolts. Axles could be wooden rods, wire hangers, nails, and metal or plastic tubing. Materials that are rough or rubber-like and can be used to add traction are rubber o-rings, rubber bands, cloth tape or silicone caulking. Sources of wheels (or materials to make wheels from) could be toy wheels, thin plywood, foam core, tape spool, wood dowels, balsa wood, stiff plastic sheeting, thread spool, cds, small cans, and lids.
- The axle needs to go through the absolute center of your wheel. If you make your own wheels, extremely accurate measurement is important. Also, the wheels must be perfectly round!
- You can either design your wheel and axle assembly to be one solid unit that rotates together, or you can design your wheel to spin on your axle by using wheels that have ball bearings in the hubs. If your wheels rotate with the axle, they must be firmly attached to the axle – slippage will cause a loss in momentum. Some manufactured wheels have a

slightly smaller hole than the diameter of the axle. This is known as a ‘push-fit’, and is one way of making sure the two fit very tight.

- If you choose to use a lubricant, different lubricants work better with different materials. Some appropriate lubricants for your Sprint car bearings may be light oil, light grease, or graphite powder. Experiment with several lubricants to find out what works best.
- Remember that the diameter of the drive wheels affect the final transmission ratio of your car – a larger wheel diameter gives a higher overall gear ratio. Gearing will be investigated in the next section.
- Test and retest your vehicle during different stages of construction. When you get your wheels attached to your chassis, check them to make sure they spin freely! You may even want to test a couple different types of wheels on a slanted board to see which rolls the easiest. Remember, it’s easier to change and modify your vehicle now than it is when it’s completely assembled.

After you assemble and attach your wheels and axles to your chassis, be sure to perform a ‘spin test’ on each of your wheels. If your wheels do not spin freely you need to figure out what the problem is and correct it before going further on your vehicle’s construction.