

OXFORD CRYOSYSTEMS

600 Series Cryostream Cooler

Operation & Instruction Guide

600 SERIES CRYOSTREAM COOLER

Operation & Instruction Guide v4.3a

Oxford Cryosystems
3 Blenheim Office Park
Lower Road
Long Hanborough
Oxford OX8 8LN
United Kingdom
Phone +44 1993 883488 • Fax +44 1993 883988
Email CryostreamSupport@OxfordCryosystems.co.uk

© 1997, © 1998, © 1999 Oxford Cryosystems. All Rights Reserved.

Introduction	4
Please Register your Cryostream Cooler!.....	4
How the Cryostream Cooler Works	5
Items Required for Assembling your Cryostream Cooler	7
Items Supplied for the Cryostream Cooler Maintenance.....	7
Getting Started.....	8
Setting Up.....	9
Using the Varibeam Coldhead Support Stand.....	9
Assembly and Positioning of the Varibeam Coldhead Support Stand.....	9
Mounting of the Cryostream Cooler Coldhead on the X-ray System	9
Connecting Up the Cryostream Cooler.....	12
The Nylon Tubing and Quick-Fit Connectors.....	13
Connecting up a Dry Air Shroud Gas.....	14
Dewar Vessels.....	14
Ice Blocks.....	16
How and why Ice Blocks Occur.....	16
Causes of an Ice Block.....	16
Ice Block Message Appears on the Screen	17
Stainless Steel Line Drier Units	18
Before Fitting and Using your Line Drier Unit.....	18
Fitting and Using your Line Drier Unit	18
Regenerating the Line Drier Unit	18
Evaporator Heater	20
Running the 600 Series Cryostream Cooler	21
600 Series Cryostream Cooler Temperature Controller.....	21
Final Checks Before Switch On.....	22
Warm Flow Test.....	22
How to Switch the Cryostream Controller On	22
Cryostream Cooler Initialisation and Screen Options.....	22
Cryostream Cooler Status Screen.....	23
Cryostream Cooler Phase Table.....	25
How to Program the 600 Series Cryostream Controller	26
Example of a More Detailed Program	27
While the Cryostream Cooler is Running.....	28
HOLD Button.....	29
Refilling the Dewar Vessel.....	29
How to Shut Down the Cryostream Cooler.....	29
List of Phases	30
Cryostream Cooler Shut Downs.....	31
10 Steps to Program the Cryostream Cooler to 100K	31
Adjusting the Evaporator Heater Temperature	33
Measuring the True Crystal Temperature.....	34
Connecting the Controller to a Computer via the Remote Interface	35

Chart Output	38
Pumping Down the Vacuum Space in the Cryostream Cooler.....	39
The Cryostream Cooler Diaphragm Pump.....	41
Cryostream Cooler Service.....	42
Liquid and Gaseous Nitrogen Safety Sheet.....	43
General.....	43
General Properties.....	43
Fire and Explosion Hazards.....	43
Health Hazards	43
Precautions.....	44
Personnel Protection.....	45
Emergencies	45
Asphyxiation	45
Treatment of Cold Burns and Frostbite.....	45
First Aid.....	45
Treatment by Medical Practitioner or Hospital.....	45
Hypothermia	46
Liquid Nitrogen Spillage.....	46
Cryostream Cooler Troubleshooting Guide	47
Condensation and/or ice covering the outside of the blue Coldhead or the flexible transfer line.....	47
Localised ice spot on the flexible line.....	48
Localised icing on the Coldhead SUCT connector and tubing.....	48
Localised ice formation around the neck of the Dewar and the Cryostream Cooler leg	48
Inability to reach low temperatures	49
Inability to reach low temperatures and the base temperature begins to rise.....	49
Controller Status reads 'Ice Block warning will trip at 2 l/min'.....	50
Ice formation on the sample	51
Feather of ice forming from inside the cold stream nozzle and extending towards sample.....	53
Ice formation on outer edge of the nitrogen gas cold stream nozzle.....	54
Concentric formation of ice around the nozzle.....	54
Spitting of liquid nitrogen from the nozzle	54
Unstable gas temperature.....	55
Cryostream Cooler maintains an error of a few degrees that disappears when the Dewar is topped up.....	56
Cryostream Cooler Shutdown due to low flow after a few seconds of running.....	56
Cryostream Cooler Shutdown due to low flow - no explicable reason.....	57
Cryostream Cooler Shutdown due to ice block	57
Cryostream Cooler Shutdown due to large temperature error.....	59
Cryostream Cooler Shutdown due to large temperature error with unusually high or low GasT.....	60
Cryostream Cooler Shutdown due to large temperature error when refilling the Dewar.....	60
Cryostream Cooler fails to initialise due to Gas Heater >64 ohms or <30 ohms.....	61
Cryostream Cooler fails to initialise due to Gas Sensor Error.....	61
Cryostream Cooler fails to initialise due to Evap Heater or Evap Sensor error	61
Diaphragm Pump is making a strange noise.....	62

Nitrogen Circuit Gas Leak Test.....	62
Flashlight Test.....	63
Technical Support	63

Introduction

Welcome to the Oxford Cryosystems Cryostream Cooler operating and instruction guide. The Cryostream Cooler is the world's leading nitrogen gas low temperature attachment for x-ray crystallography and is designed for use in the freezing of macromolecular, small molecule and powder samples during the collection of x-ray data. It can be used for all applications from shock cooling to lengthy data sets lasting many weeks.

Its versatility and flexibility means it can be fitted to practically any x-ray system including an Image Plate System, CCD Detector, Eulerian Cradle Four Circle Diffractometer, Kappa Diffractometer or Powder Diffractometer. Due to its unique design, the Cryostream Cooler operates from 80K to 375K, with a gas stability of 0.1K and a very economic liquid nitrogen consumption of 0.6 litres of liquid nitrogen per hour. The outstanding performance of the Cryostream Cooler has been achieved by drawing the liquid nitrogen out of an unpressurised Dewar vessel using a continuous flow gas pump.

Before using the Cryostream Cooler, please read the section, 'Liquid and Gaseous Nitrogen Safety Sheet'.

Please Register your Cryostream Cooler!

Help us to help support you when you need it. Please visit our Cryostream Cooler Registration Page at www.OxfordCryosystems.co.uk.

Please fill in the fields on the form as comprehensively as possible to allow us to make contact with you.

How the Cryostream Cooler Works

The figure below illustrates the gas flow circuit of the Cryostream Cooler.

Cryostream Cooler
Layout

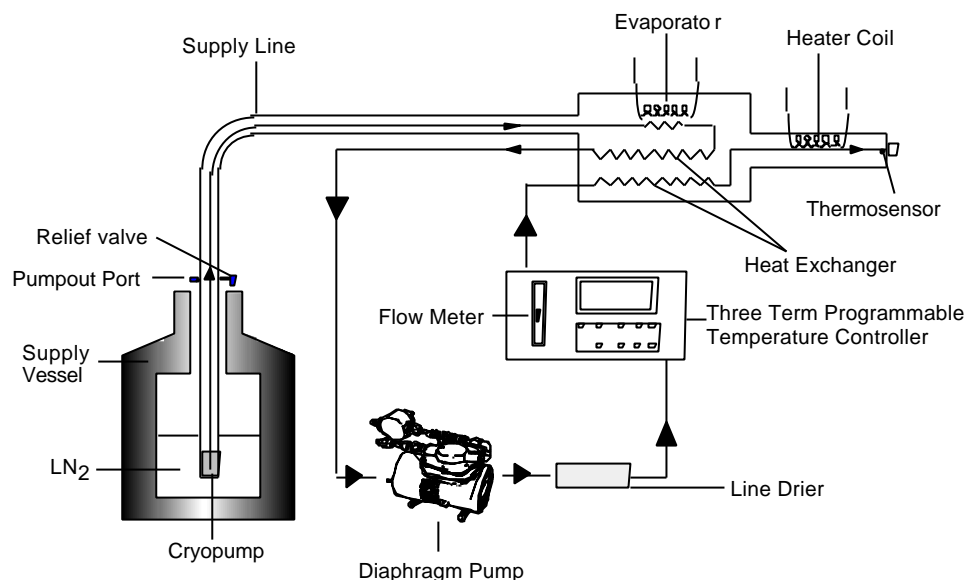

Liquid nitrogen is drawn up by the action of the Diaphragm Pump from an unpressurised Supply Vessel, through a flexible vacuum insulated Supply Line, into the Cryostream Cooler Coldhead. The Supply Vessel can be any convenient container of liquid nitrogen such as a conventional metal Dewar. Please note that the Dewar vessel is *not* sealed. This is a unique feature to Cryostream Cooler.

The liquid nitrogen, once inside the Cryostream Cooler Coldhead, passes through a heater called the Evaporator Heater, which evaporates most of the liquid into vapour at the boiling point of liquid nitrogen. This vapour then flows outward along one path of the Heat Exchanger, through the Cryostream Cooler Temperature Controller, to arrive at the inlet of the Diaphragm Pump at approximately 10K below room temperature. The nitrogen gas from the pump is then dried with a Line Drier Unit. The flow rate of the gas from the pump is then regulated by a needle valve in the Cryostream Cooler Temperature Controller. This gas flows back into the Cryostream Cooler Coldhead where it is re-cooled along the second path of the Heat Exchanger.

Therefore, the main Heat Exchanger carries the gas streams to and from the constant-flow pump that operates at room temperature. The nitrogen flow rate is pre-set by the needle valve at 5 litres / minute. After returning to the cold end of the Heat Exchanger, the gas enters the delivery nozzle to pass over a gas heating coil called the Gas Heater, and a Thermosensor which regulate the temperature of the gas stream, before emerging to cool the sample.

The flexible liquid nitrogen Supply Line, the Heat Exchanger, Evaporator Heater and delivery nozzle share a common high-vacuum insulation jacket which is pumped out and sealed before use. An Adsorption Cryopump is built into the end of the rigid part (leg) of the Supply Line to increase the strength of the vacuum when plunged into liquid nitrogen.

The 600 Series Cryostream Controller is designed specifically to manage the Cryostream Cooler. The three terms of this programmable Controller are used to control the Evaporator Heater and its temperature sensor, the Gas Heater and Thermosensor, and to monitor ice blocks in the Coldhead.

The Cryostream Cooler flow rate is fixed by the flow valve at approximately 5 litres / minute of gas, this equated to approximately 0.6 litre / hour of liquid nitrogen. This means an average 25 litre Dewar will last for more than one day of continuous use and a 60 litre Dewar will last from Friday afternoon to Monday morning. The rate of consumption does not depend on the temperature of the experiment, but it is worth noting that different Dewars have different rates of boil off, so it is worthwhile taking this into consideration when running the Cryostream Cooler and leaving it unattended for long periods.

Because the Cryostream Cooler applies the same gas pressure at the crystal as it does in the Dewar, it is safe to replenish the supply of liquid nitrogen to your Dewar at any time without any fluctuations in gas temperature. This can be simply done by pouring or using a mild pressure secondary Dewar or an automatic refilling system.

Items Required for Assembling your Cryostream Cooler

The component parts of the system are:

1. The Cryostream Cooler Coldhead and flexible transfer line (integral)- Supplied
2. 600 Series Cryostream Controller - Supplied
3. A Diaphragm (Gas) Pump - Supplied
4. Interconnecting nylon tubeset. Including:
 5. One long blue tube and one short blue tube - Supplied
 6. One long green tube and one short green tube - Supplied
 7. One red dry air tube - Supplied
8. Grey Coldhead cable - Supplied
9. A Varibeam Coldhead Support Stand - Optional Extra
10. An AD31 or AD41 Dry Air Unit- Optional Extra (or alternative dry gas supply).
11. Line Drier Units – Optional Extra
12. Dewar Vessel – Either an Oxford Cryosystems ES-60 Dewar or a suitable alternative (See later.)

Items Supplied for the Cryostream Cooler Maintenance

1. A CRH25 Reactivation Heater - Supplied
2. A Pumpout Adaptor - Supplied

Getting Started

Matching the Cryostream Cooler Coldhead and 600 Series Controller

The Cryostream Cooler Coldhead and 600 Series Controller are supplied as a matched pair - the individual characteristics of the Coldhead sensors are programmed into the Controller. Please contact your supplier if you believe you may have unmatched units.

The serial number of the Coldhead is engraved on the stainless steel top flange in amongst the connectors near the flexible transfer line. The serial number of the Controller is shown on the top right-hand corner of the rear panel and the number of the matched Coldhead is also shown near the Coldhead connections on the rear panel.

Oxford Cryosystems request that you always quote this number in any communications to allow us to provide comprehensive technical support.

Operating Voltage

It is essential that the Cryostream Cooler is configured to operate on the local mains electrical supply. Check the following:

Item	Operating Voltage Requirements
Cryostream Controller	The voltage selector switch on the rear panel must be set to the correct position, 200-240 Volts AC, 50Hz, 3 Amps 100-120 Volts AC, 50-60Hz, 6 Amps. Make sure an 'Anti-Surge' (T) type fuse of the correct rating is fitted.
Diaphragm (Gas) Pump	Three voltage variants are currently available: 220-240 Volts AC, 50 Hz 115 Volts AC, 60Hz 100 Volts AC, 50-60Hz Make sure you have the correct pump.
CRH25 Reactivation Heater	Two voltage variants are available: 230 Volts AC 115 Volts AC

Setting Up

Using the Varibeam Coldhead Support Stand

The Varibeam is an extremely robust and rigid stand that will support the Cryostream Cooler Coldhead on almost all x-ray systems. The Varibeam has a leadscrew positioner that allows the Cryostream Cooler nozzle to be positioned very accurately at the crystal and then retracted along a scale when access is required. This facility is often very useful where accurate and repeatable alignment is important.

The stand can be assembled in various configurations; the rotation of the horizontal arm; angling the nozzle between 20° and 90°; and the block gripping the Cryostream Cooler Coldhead can be removed and fitted onto the other side of its support plate. This stand will support and guide the Coldhead in all configurations.

Assembly and Positioning of the Varibeam Coldhead Support Stand

The Varibeam column and cross-arm are tough anodised aluminium to give an extremely tough finish. When the stand is being put together, try to avoid bolting the Varibeam in a position which causes obstruction where access to the crystal is important, collision with any microscopes or circles of the diffractometer, or obstruction to x-ray tube housing.

If you are unsure of exactly where you want to position the Cryostream Cooler on your system, try setting it up on a desktop first to give you a chance to consider all the options. Alternatively, use the blue Mounting Pin supplied with the support stand as a guide for aligning the real Coldhead nozzle. For determining the exact crystal position, simply place a fibre in the small hole at the end of the blue Mounting Pin, or use the Nozzle Alignment Tool (available separately).

The Varibeam is supplied with bolts to allow the user to securely fix the stand to the cabinet tabletop. Users are often reluctant to drill holes without first experimenting with various positions first. If this is so, use a G-clamp (C-clamp) to temporarily fix the Varibeam to the tabletop. If the positioning point of the Varibeam base is not close enough to the edge of the table top, try bolting the stand to a flat sheet of metal which can be clamped to the edge of a cabinet top.

In many cases bolting the Varibeam to a cabinet top can prove quite a lot of work or is just not practical, so try using tapping screws to fix the support stand in place. Make sure the cabinet top is sufficiently strong enough to prevent the tapped screws from tearing from it.

Mounting of the Cryostream Cooler Coldhead on the X-ray System

The mounting of the Cryostream Cooler Coldhead depends on the particular x-ray system being used. Oxford Cryosystems recommend the use of the Varibeam Coldhead Support Stand to mount the Cryostream Cooler Coldhead on all x-ray systems.

Note:

The following rules and instructions are guidelines only and if a user has an alternative technique for mounting the Cryostream Cooler then they are welcome to use it. If the user is in anyway unsure of the mounting of the Cryostream Cooler contact your local Cryostream Cooler supplier or Oxford Cryosystems for advice.

General Rules

There are a few general rules the user should consider when mounting the Coldhead and fixing the support stand in position.

1. Do not point the nitrogen cold stream at the detector.
2. Try to limit the amount the Cryostream nozzle infringes the path of the x-rays.
3. Do not point the cold stream at any optical device or gearing. (These devices need to be more than 15cm away).
4. Do not mount the cold stream coaxial with the goniometer head, this will cause icing problems.
5. Do not fix the stand to your cabinet top so it prevents access to your x-ray tube, prevents the detector being swung in theta or makes access to the crystal difficult.
6. The Cryostream Cooler Coldhead should only be mounted between 90° (vertical) and 20°. This avoids condensation collecting inside the nozzle and puddling of liquid nitrogen in the Heat Exchanger which can result in the spitting of liquid nitrogen from the nozzle.
7. The crystal should be less than 8mm from the end of the nozzle in the centre 3-4mm of the gas stream, this will help to prevent icing. The Oxford Cryosystems Nozzle Alignment Tool is idea for this application (available separately).
8. The Supply Line is made out of flexible tubing containing a very fine continuous metal capillary. This should not be flexed to a radius of less than 200mm so **DO NOT BEND THE FLEXIBLE SUPPLY LINE TOO SHARPLY**. Obviously, the more the Supply Line is flexed the more likely it is to fatigue.

Setting Up on Eulerian Cradle Four Circle Geometry (eg Bruker AXS P4)

The Cryostream Cooler Coldhead should be mounted so that the nozzle enters the chi circle over or close to the collimator at an angle of 45°. There maybe a need to reduce the movement of the omega circle so that the goniometer does not hit the nozzle of Cryostream Cooler. The Varibeam stand should be mounted behind the x-ray housing and toward the back of the cabinet, with respect the path of the x-rays.

In the newer Bruker AXS cabinets, there is often a slot in the back for the cooling hose of their CDD Detector. This also makes for a very useful access point for the Supply Line. It is likely the Dewar vessel will need to be raised off the floor so the Supply Line can reach the bottom of the vessel. This slot is also a very good port for the nylon tubing and Coldhead Cable.

Setting Up on Kappa Four Circle Geometry (eg Nonius CAD4)

The Varibeam Support Stand should be mounted either to the left or right of the x-ray housing to reduce interference when accessing the crystal and the movement of the detector. The Cryostream Cooler Coldhead should then be mounted vertically over the crystal. There is some freedom to move away from vertical if necessary. This set up will require a hole to be machined in the cabinet top and it is likely the Dewar vessel will need to be raised off the floor so the Supply Line can reach the bottom.

Setting Up on the Marresearch Image Plate Detector

There is plenty of access into the crystal on the Marresearch image plate system and although there is a temptation to mount the Cryostream Cooler vertically over the horizontal goniometer one must be careful to avoid pointing the cold stream at the CCD camera pointing up from underneath. We recommend the user tilts the Coldhead from 90° vertically to about 55° either away from the goniometer housing or towards the goniometer housing. The position will depend on which side the user wishes to gain access to the crystal.

On the Marresearch image plate the crystal is mounted very close to the collimator and often results in the collimator infringing on the dry air shroud or cold stream of the Cryostream Cooler. This can cause icing and temperature fluctuations, so it may be necessary to modify the collimator. Do not rush into this modification.

Modification to Marresearch Image Plate Collimator

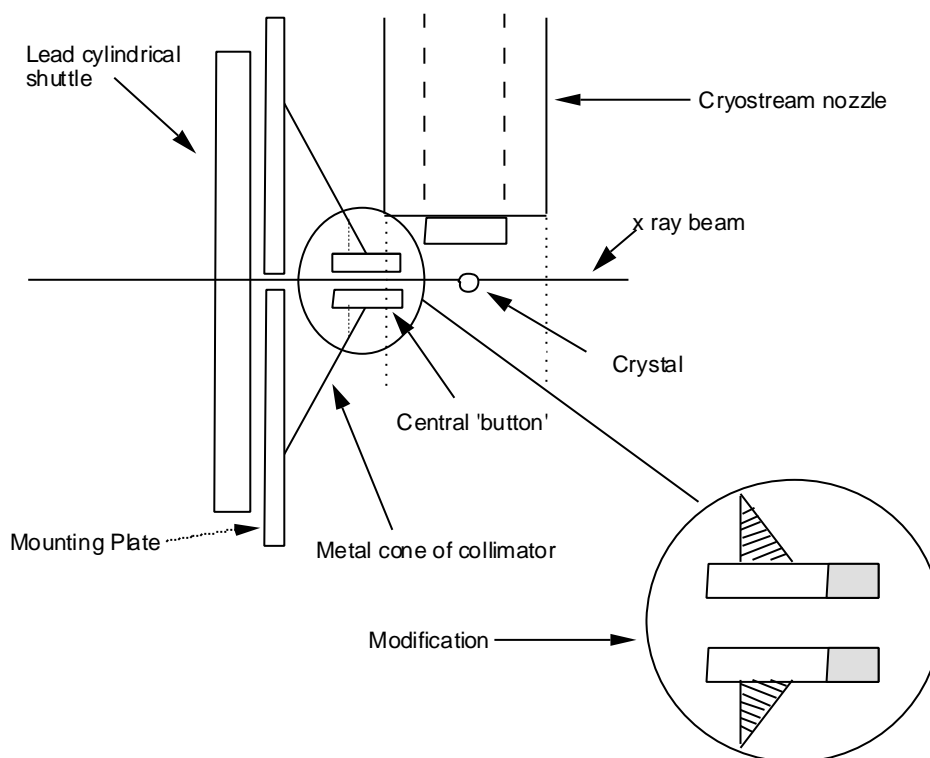

Setting Up on the Rigaku R-Axis Image Plate Detector

The Cryostream Cooler Coldhead should be mounted opposite the microscope, perpendicular to the x-ray beam path, at a fairly unrestricted angle of between 55° and 20° from horizontal (ideally about 45°). If the R-Axis is fitted with both a CCD camera and a microscope, then one may need to be removed depending on the amount of space available. If the Coldhead is any steeper than 55° the goniometer may interfere with the Laminar Flow of the cold stream and cause icing to occur. The Varibeam Coldhead Support Stand is ideal for this application.

Setting Up on the Bruker AXS SMART CCD System

The Cryostream Cooler should be mounted so the Coldhead is as close to vertical as possible. If 90° is vertical, then mount the Coldhead at about 80°. This steep angle is necessary as manufacturers continue to increase the diameter of the detector. The Varibeam stand should be mounted behind the x-ray housing and toward the back of the cabinet, with respect the path of the x-rays.

In the newer Bruker AXS cabinets, there is often a slot in the back for the cooling hose of their CDD Detector. This also makes for a very useful access point for the Supply Line. It is likely the Dewar vessel will need to be raised off the floor so the Supply Line can reach the bottom of the vessel. This slot is also a very good port for the nylon tubing and Coldhead Cable.

Connecting Up the Cryostream Cooler

Tube and Cable
Connection Scheme

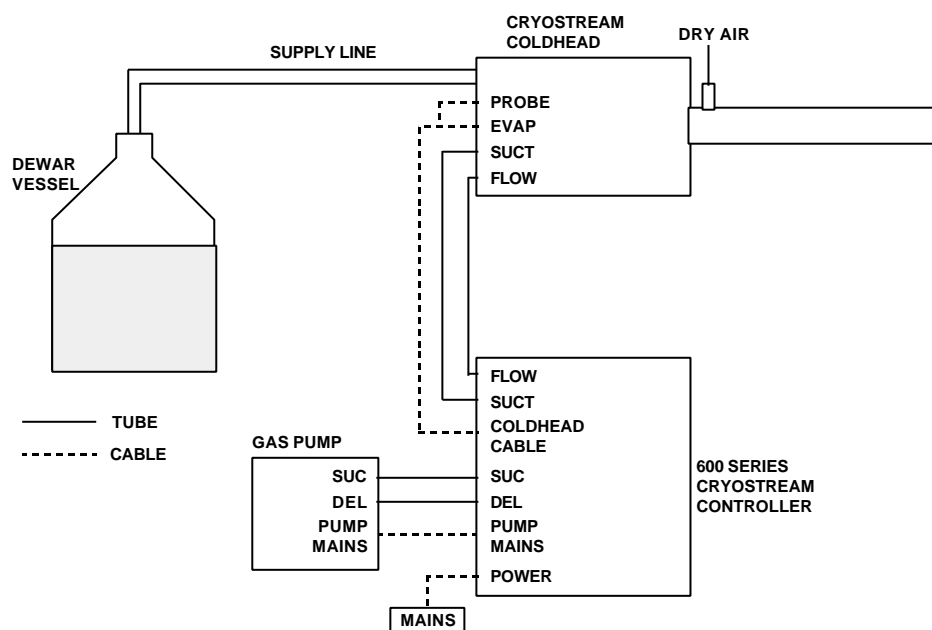

The diagram above illustrates all the connections that have to be made, full lines denote 6mm (outside diameter) nylon tubing and the dotted lines denote electrical cables. Connections are generally labelled equivalently at each end. (The table below outlines which tubes go in which connectors). The Nylon Tubeset provided with the Cryostream Cooler consists of five 6mm (outside diameter) nylon tubes:

1. one long blue tube
2. one short blue tube
3. one long green tube
4. one short green tube
5. one red tube.

The Nylon Tubing and Quick-Fit Connectors

The tubing fits into the Quick-Fit Connectors on the Cryostream Cooler Coldhead, in the back of the Cryostream Controller and into the connectors on the Diaphragm Pump. Each tube must be cut squarely with a sharp knife to ensure it seats correctly into each Quick-Fit Connector. Make sure the ends of the tubes are circular and not crushed.

Please use the following Oxford Cryosystems convention for fitting each tube into its connector:

Tube Type	Connector / Location	connected to	Connector / Location
Long Blue Tube	SUCT / Coldhead	connected to	SUCT / Controller
Short Blue Tube	SUC / Controller	connected to	SUC / Diaphragm Pump
Short Green Tube	DEL / Diaphragm Pump	connected to	DEL / Controller
Long Green Tube	FLOW / Controller	connected to	FLOW Coldhead

Push firmly on each nylon tube to be sure that it does not leak. Each tube should be pushed 15-16mm into each of the connectors. Ensure that none of the nylon tubes are pulled to one side in any of the connectors.

Quick-Fit Connector

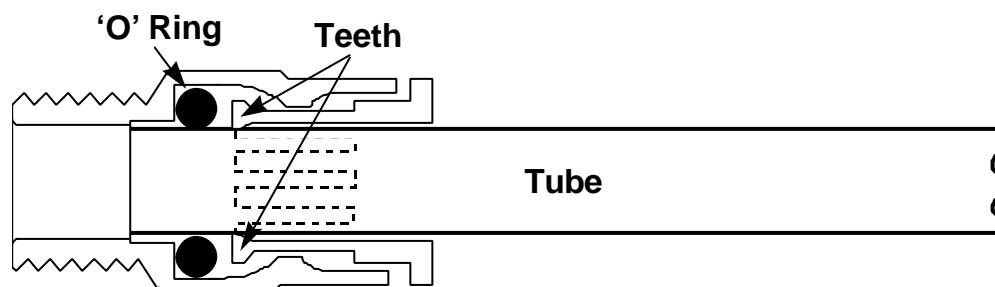

The above diagram shows a cross section of a nylon tube in a Quick-Fit Connector. The teeth (indicated) grip the tube when it is pushed into the connector. THIS DOES NOT SEAL THE TUBE IN THE CONNECTOR. THE TUBE MUST BE PUSHED THROUGH THE 'O' RING TO MAKE IT AIR TIGHT, A TOTAL DISTANCE OF 15-16MM.

Take the opportunity, when the system is first put together, to mark each nylon tube with a black marker pen to ensure they are seated properly. Each tube should be pushed in 15-16mm.

Connecting up a Dry Air Shroud Gas

The system is now set up to deliver nitrogen gas but in order to operate in an ice free environment at low temperatures, the nitrogen gas stream requires a shroud gas as it exits the nozzle. This gas can be either dry air with a dew point of less than -60°C or an inert gas such as nitrogen that is often fed in and piped around laboratories. Oxford Cryosystems manufacture the AD41 Dry Air Unit that is a stand-alone unit that provides a constant stream of clean dry air and is ideal for this application.

Attach the red nylon tube from the tube set to the side connector on the delivery nozzle of the Cryostream Cooler Coldhead, a right angle connector is provided.

Insert the rigid leg at the end of the flexible Supply Line into an open Dewar vessel (see next section on Dewar Vessels) containing liquid nitrogen. Always make sure that there is enough nitrogen in the Dewar vessel to cover the bottom five or six inches of the rigid Supply Line. This is vital, as the Cryopump in the leg needs to be plunged in liquid nitrogen to insure a good vacuum.

Press some insulating material into the neck of the Dewar, (a white Teflon bung is provided with the Oxford Cryosystems ES-60 Dewar Vessel), and around the Supply Line in order to minimise boil off and to prevent the development of ice. However, the Dewar must not be sealed! More elaborate neck fittings can be constructed, but always remember to vent the Dewar.

Dewar Vessels

The purpose of the Dewar vessel is to hold the liquid nitrogen supply used by the Cryostream Cooler. There are a number of variables to consider when deciding on which Dewar vessel to purchase for use with the Cryostream Cooler.

1. Capacity - this is the most important consideration when deciding on a Dewar.

Note

It is important to remember that the rigid Supply Line of the Cryostream Cooler is plunged into the Dewar and is only 700mm long, so it can only utilise the top 650mm of a Dewar vessel. It is all very well using a 100 litre Dewar, but if the rigid Supply Line does not reach the bottom, the Cryostream Cooler can not utilise its full capacity.

The recommended capacity is between 30 and 60 litres, although be warned that most commercially available 60 litre Dewars are too deep for the Cryostream Cooler to utilise. Oxford Cryosystems supply a 60 litre Dewar called the ES-60 which when filled, will allow the Cryostream Cooler to run from Friday lunch time to Monday lunch time without needing to be refilled.

2. Construction – either stainless steel or aluminium (aluminum).
3. Neck Opening Size – Dewar necks vary in size. If the opening is too small, there may be problems refilling the Dewar. If the Dewar opening is too large, then the rate of boil off will be very high and contaminants will get into the liquid nitrogen. The Oxford Cryosystems ES-60 Dewar vessel has a neck opening of 5cm.

Ice Blocks

How and why Ice Blocks Occur

For a variety of reasons, it is quite common for small quantities of water vapour to contaminate the nitrogen gas stream flowing through the Cryostream Cooler. If sufficient water is present, an ice blockage will form which can reduce the flow rate or cause a Low Flow trip - this process should take 5-7 days or even several weeks, depending on water vapour content.

Causes of an Ice Block

The block forms in the FLOW path of the Cryostream Cooler as the nitrogen gas is cooled from room temperature back down to liquid nitrogen temperature in the Heat Exchanger. Two possible sources of water vapour are ice in the liquid nitrogen or an inward leak in the SUCT or SUC paths of the gas circuit usually resulting from a badly nested Quick-Fit Connector. A third source is a split diaphragm in the Diaphragm Pump but this is not likely to happen until the Diaphragm Pump has run for approximately 10,000 hours.

Ice Block Message Appears on the Screen

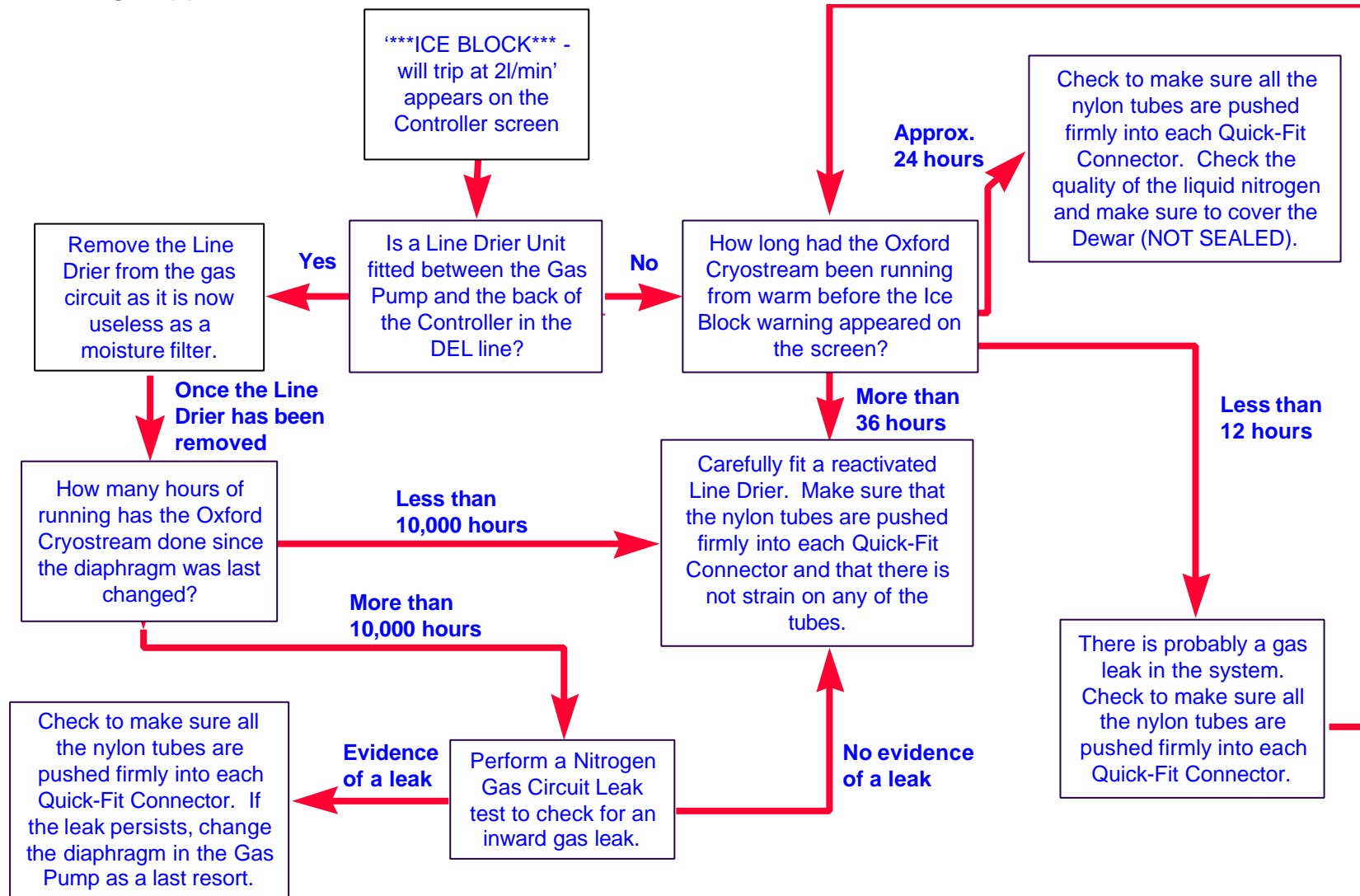

Stainless Steel Line Drier Units

Line Drier Unit



Before Fitting and Using your Line Drier Unit

When first installing your Cryostream Cooler, run the system without fitting the Line Drier. If there are any inward leaks or a high level of ice in the liquid nitrogen, the Cryostream Cooler will block in a few days but will not contaminate the Line Drier with water. If this occurs, recheck all the Quick-Fit Connectors (pressing them in 15-16mm,) check the liquid nitrogen in the Dewar vessel for ice contamination then rerun the system. The Cryostream Cooler should run for about 5-7 days before a block occurs, although poor quality nitrogen can reduce this to 2-3 days. (An ice block warning will appear within two or three days, in the Status line on the 600 series Cryostream Cooler only.) If none of these signs appear then the quality of the liquid nitrogen is very good.

Note

Use the flow diagram on the previous page before fitting the Line Drier.

Once the system has run for about a week, fit your Line Drier.

Fitting and Using your Line Drier Unit

The Line Drier is designed to remove traces of water vapour from the nitrogen stream before an ice block can form. It will not cope with gross contamination of the nitrogen supply or a large inward leak.

Check that all the nylon tubes are pushed firmly (approx 15-16mm) into each Quick-Fit Connectors. Also warm up and clean out the liquid nitrogen vessel at regular intervals, keep the vessel neck covered to prevent atmospheric moisture and 'rubbish' getting into the Dewar. Also ensure the liquid nitrogen is of good quality.

Remove the Blanking Plugs, (these plugs must be fitted to the Line Drier during transit and storage.) Fit the Line Drier Unit in the FLOW gas circuit pipework. This is between the FLOW connector on the Cryostream Coldhead and the FLOW connector on the Cryostream Controller. Fit the Line Drier as close to the Cryostream Coldhead FLOW connector as possible. Do not leave the line drier open to the atmosphere, this will avoid contamination.

Regenerating the Line Drier Unit

Eventually the Line Drier will become saturated by water and require regenerating. To regenerate, disconnect the Line Drier and unscrew the Metal End Fittings at each end to avoid heat damage to the rubber 'O' ring seals.

There are two important things to achieve when reactivating Line Driers:

To heat the Line Drier evenly all around its body to at least 250°C. Do not exceed 300°C. This is achieved most successfully using:

1. Heating Tape / Strip (1.5 metres, 240 watts).
2. Oven with access for the purging gas stream.

DO NOT USE:

1. Sealed oven with no gas flow through the Line Drier.
2. Heating Mantle.
3. Naked flame!!

Purge the Line Drier with a steady stream of inert cylinder gas (eg. Nitrogen, helium etc). Inject the purge gas through a short (300mm) length of stainless steel tube to act as a heat break to the OUT connector of the Line Drier, small leaks at the couplings do not matter. The OUT connector size is ¼" BSP. The gas flow should be set to 1-2 litres/minute. DO NOT USE DRY AIR FROM THE DRY AIR UNIT. THIS GAS IS NOT DRY ENOUGH.

After a minimum of 4 hours switch off the supply of heat, but allow the gas flow to continue until the Line Drier is cool (approx 2 hours). Replace the Metal End Fittings and Blanking Plugs immediately.

Typical Reactivation
Set Up

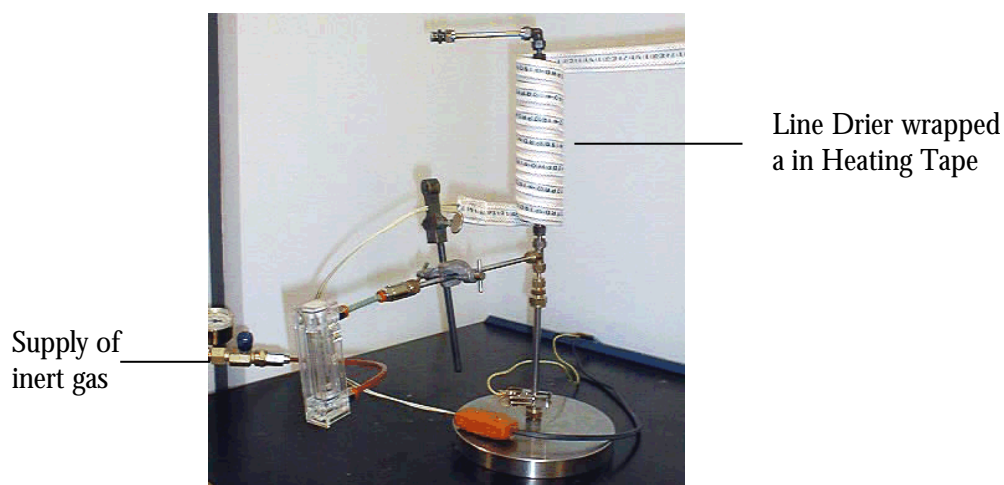

The picture above illustrates an example of the reactivation procedure used by Oxford Cryosystems.

Evaporator Heater

In addition to the Gas Heater (and Thermosensor) a second heater/sensor combination is fitted to the Cryostream Cooler, called the Evaporator Heater. The purpose of the Evaporator Heater is to convert most of the liquid nitrogen flowing into the Cryostream Cooler Coldhead to gas at its boiling point. This is necessary because the Latent Heat of Evaporation of liquid nitrogen represents excess refrigeration of which only a fraction is needed to make up for heat leaks and Heat Exchanger inefficiency. If both paths of the Cryostream Cooler Heat Exchanger contain gaseous nitrogen, the Cryostream Cooler can control the heat exchange process with more control than with an interphase Heat Exchanger.

For most purposes the Evaporator is automatic and the EVAP key can be ignored. However, it may be necessary to adjust EvapT manually when operating at a Gas Temperature below about 95K, although this number varies from system to system. The reason for adjusting the Evaporator Heater setting is to allow colder gas to pass through the SUCT path of the Heat Exchanger. This means that the heat exchange gas passing down the FLOW path of the Heat Exchanger is cooled down to a lower temperature. (To adjust the setting of the Evaporator Heater see 'Adjusting the Evaporator Heater'.)

The temperature of the Evaporator is displayed on the Status Screen in the EvapT box.

Due to the inefficiencies of the Heat Exchanger, EvapT does not indicate the minimum Gas Temperature obtainable.

Running the 600 Series Cryostream Cooler

600 Series Cryostream Cooler Temperature Controller



600 Series Cryostream Controller- Front View



600 Series Cryostream Controller- Back View

The 600 Series Cryostream Cooler Temperature Controller is designed to provide a completely flexible means of controlling temperature with up to about 10¹¹ temperature segments. This is achieved by allowing the user to enter up to 99 phases, each one itself providing a complex series of segments.

Final Checks Before Switch On

Make sure:

1. All the nylon tubes are pushed firmly into their Quick-Fit Connectors. Each one should be seated 15-16mm into its connector.
2. There is liquid nitrogen in the Dewar and the Cryostream Cooler rigid Supply Line is in the Dewar vessel.
3. That if a dry air shroud is required, it is connected to the Quick-Fit connector at the top of the Cryostream nozzle.

Warm Flow Test

Once the system has been connected together, it is worthwhile checking to see this has been done properly. There is a simple procedure called the Warm Flow Test where the gas flow path is checked by connecting the Diaphragm Pump power cable directly to the mains supply. This can be done by disconnecting the power cable for the Diaphragm Pump and the mains cable from the back of the Controller. These two cables are Male and Female and can be connected together.

The Diaphragm Pump draws liquid out of the Dewar vessel into the Cryostream Cooler Coldhead. The heaters are not functioning and there is no mains power to the Controller, but by looking at the flowmeter on the front panel of the Controller it is possible to see how the gas is behaving. The float will be at about 4 litres / minute. This is normal and will increase to 5 litres / minute as the system cools down. If the gas flow is correct, reconnect the mains cable and the Diaphragm Pump power cable.

How to Switch the Cryostream Controller On

If the system has been connected up correctly and the supply line has been placed into the liquid nitrogen Dewar vessel, press the 'ON' switch for the Cryostream Controller which is on the left hand side of the rear panel of the Controller, underneath the Heat Exchanger.

Cryostream Cooler Initialisation and Screen Options

As the Controller is switched on, it undergoes an Initialisation process and a Self Check procedure. During the Self Check, the Cryostream Controller checks to make sure all parts of the Cryostream Cooler system are working properly. A small tick appears by each item being checked.

Initialisation Screen

*****		*****	
CRYOSTREAM CONTROLLER		Type 611	
Self-Check Screen		Ver: 2.5	
*****		*****	
Coldhead Cable	✓	✓ Evap. Th.	0.513 V 292K
Flow/Ice Sensor	✓	✓ Gas Th.	0.592 V 291K
Overheat Sensor	✓	✓ Gas Heater	51 Ohms

The CONTRAST control on the rear panel may need to be adjusted to obtain the best display on the screen. If everything is working properly, each item should be ticked and with values similar to those indicated here, (the figures will vary slightly with different Cryostream Coolers).

The 600 Series Cryostream Controller interface consists of two screens:

The Status Screen – Shows the current state of the Cryostream Cooler including its current gas temperature, error, Evaporator temperature and Heat%. The Status Screen also shows the current phase the Cryostream Cooler is performing.

Note:

A Phase is a procedure performed by the Cryostream Cooler RAMPing, PLATeau, HOLD, END, SLAVE. See the List of Phases for further details.)

The Phase Table – This is where the instructions can be entered. It contains a table in which to enter Phases.

Cryostream Cooler Status Screen

The Initialisation screen will disappear to be replaced by a Status Screen similar to this:

Status Screen

293.4	Gas Temp K	Error	EvapT 293 K	Heat 0%
STATUS: Ready				
PROMPT: Press PROGRAM to start next phase				
Press SCREEN to view phase table				

The Status Screen is made up of seven parts:

1. The top left-hand box (293.4K Gas Temp) is the temperature of the gas stream. When the system is first switched on, it should read room temperature. This number is measure by the Thermosensor just inside the Cryostream nozzle. (See 'How the Cryostream Cooler Works').
2. The next box contains the gas temperature error (Error). This is how much the gas temperature varies based on an internal voltage reference and is functional when the Cryostream Cooler is running.
3. The next box is the Evaporator temperature (EvapT 293K). This is a measure of the temperature of the Evaporator Heater (See Evaporator Heater).
4. The last box contains Heat 0%. This is a very useful reading and tells the user how much heat the Gas Heater is putting in to warm up the gas stream from liquid nitrogen temperatures to the required temperature. For example, at room temperature this heater may read around 70% as the Cryostream Cooler needs to warm it up a lot from about 80K. At 100K this value will be much lower as the Gas Heater does not heat the gas too much so will be about 17-19%.

Note:

These numbers vary from system to system and are only used as an example.)

5. The line beginning 'STATUS:' is the Status line. This informs the user of the current status of the Cryostream Cooler. Examples of this line may be:

HOLD at 100K – holding the gas temperature at 100K or,

RAMP to 120K @ 360K/HR (5.6) – Ramping the gas temperature to 120K at a rate of 360K/HR. This will take 5.6 minutes.

6. The 'PROMPT' section is a series of options in inverse video prompting the user to select an option. In this case, PROGRAM – to enter a new phase in the Phase Table, or SCREEN – to flip to view the other screen. As the Status Screen is currently visible the SCREEN key will switch to show the Phase Table.
7. The final section of the screen is only used when there is an ice block in the FLOW path of the Coldhead. When an ice block occurs, the message '*Ice Block - will trip at 2 l/min' will appear in the blank line between the Status Line and the Prompt Section.

Note that room temperature should be indicating at the top left-hand corner. When the screen backlight times out, pressing the SCREEN key switches the backlight on again.

Cryostream Cooler Phase Table

When the PROGRAM key is pressed, the user is then presented with the following screen:

Phase Table

Rate	Temp	Step	Plat	Loops
K/hr	K	K	mins	
293.4				
RAMP	120			

← Gas Temp

← Phase Column

← Default Ramp Rate

↑ Column Headings

The Phase Table is made up of four parts:

1. Gas Temp – This is the current gas temperature measured at the Thermosensor in the end of the nozzle. This number will vary depending on the current room temperature.
2. Phase Column – This is the column in the Phase Table where the type of phase is selected.
3. Column Headings – The five columns of the Phase Table where data can be entered have a heading.

Rate K/hr – The rate at which the Controller ramps to a selected temperature. The limits of the Rate are 1-360K/hr. The Cryostream Controller is programmed to cope with this whole range.

Temp K – The desired temperature the particular selected phase is programmed to reach.

Step K – The STEP phase function allows the user to reach a certain gas temperature in Kelvin step increments. This column allows the user to enter the increment.

Plat mins – The user can ramp to a desired gas temperature and hold that temperature for a specified amount of time.

Loop – It is possible to loop over the last phase in the Phase Table. See List of Phase for examples.

4. Matrix (Default Ramp Rate) – Where the data is entered.

How to Program the 600 Series Cryostream Controller

When the PROGRAM button is first pressed the user is presented with a default RAMP, (as the Cryostream Cooler can do nothing until it has ramped to a designated temperature,) and a default ramp rate.

293.4	Rate	Temp	Step	Plat	Loops
	K/hr	K	K	mins	
RAMP	120				

1. The Default Ramp Rate is highlighted so it can be changed, Use the Arrow keys on the front of the Controller to change this number from 1-360K/hr. Double headed Arrow keys change the numbers by a factor of 10 and the single Arrow keys change the numbers by a factor of 0.1.
2. Press ENTER to accept the rate.

293.4	Rate	Temp	Step	Plat	Loops
	K/hr	K	K	mins	
RAMP	310	293.4			

3. The highlighted prompt will switch to the 'Temp K' column and the gas temperature will default to the current gas temperature. Use the Arrow keys to select the required gas temperature between 77.4-375K.

When selecting an initial temperature to ramp to, it is worth running the Cryostream Cooler at room temperature until the Evaporator in the Cryostream Cooler Coldhead has cooled to its minimum temperature (around 83K.) If there is not time to perform this

function before ramping to lower temperature it will not cause the Cryostream Cooler a problem, it just means the ramp rate down to cryogenic temperatures could be somewhat erratic. This is not a problem except when a steady ramp rate is required. The stability of the final gas temperature is unaffected.

4. Press ENTER to accept the selected gas temperature.

293.4	Rate	Temp	Step	Plat	Loops
	K/hr	K	K	mins	
RAMP	310	105.5			
RAMP					

5. Having accepted the required gas temperature the highlighter then drops to the next line to prompt a new phase. For the list of available phases, see List of Phases, below. Once the Cryostream Controller has reached the end of the programmed phases, it will automatically enter a HOLD to hold the Cryostream Cooler at the current temperature.
6. To start the Cryostream Cooler running, press SCREEN to return to the Status Screen. The PROMPT section of the screen now prompts the user to press START to begin the program.
7. Press START.

Example of a More Detailed Program

The combination of phases can become quite complex depending on what needs to be achieved. Here is an example of a more detailed program.

265.5	Rate	Temp	Step	Plat	Loops
	K/hr	K	K	mins	
RAMP ↵	240	278.4			
PLAT ↵		278.4		10.0	
> STEP	120	260.0	0.1	60.0	
LOOP ↵	220	278.4			3/10
LOOP ↵					1/4

1. Starting from room temperature ramp down to 278.4K at a rate of 240 K/hour.

2. Now maintain the temperature at a plateau of 278.4 K for 10 minutes.
3. Ramp down to 260 K at a rate of 120 K/hour, but after each 0.1 K change, hold the temperature constant for 60 minutes before doing the next ramp. The > sign to the left means that this is the active phase i.e. the one that the programmer is running at the time this screen was drawn. Note that the temperature reading at the top left-hand corner (265.5 K) is the actual temperature at this time.
4. Once 260 K has been reached go back to the plateau instruction. To do this ramp to 278.4 K at a rate of 220 K/hour. This is done a total of 10 times in all. At the present time the program is on its 3rd loop.
5. Finally go back to the first ramp instruction. The whole program is rerun 4 times, and at present is on its first cycle.

It can be seen from this example that with a few lines of programming it is possible to specify a very complex set of instructions, thus making this control system almost infinitely extensive.

While the Cryostream Cooler is Running

On pressing the START button, the Diaphragm Pump will start up and at first the gas flowmeter will indicate approximately 4 litres / minute and rise to 5 litres / minute within 5 minutes. A typical screen during the control looks like this:

265.5	Gas Temp K	Error 0.1	EvapT 85.0 K	Heat 65%
<p>STATUS: RAMP to 265K @ 120K/hr (12.5)</p> <p>PROMPT: Press START to start next phase Press SCREEN to view phase table</p>				

During the first 30 minutes of operation the gas temperature may fluctuate by $\pm 0.3\text{K}$ to $\pm 0.4\text{K}$ for brief intervals as the Heat Exchanger and Evaporator cool down; avoid Ramping rapidly to below 120K during this period. The active phase is indicated by the ">" sign at the left of the Phase Table screen (press SCREEN to swap between the Status Screen and the Phase Table).

To achieve a gas temperature near 80K it maybe necessary to manually adjust the temperature of the Evaporator Heater. See the section on 'Adjusting the Evaporator Temperature.'

It is possible to ERASE any of the phases up to and including the active phase (see above). If the active phase is erased the control safely changes to a programmed HOLD.

It is also possible to add new phases while the temperature is being controlled. To do this press the PROGRAM button and add more phases. The screen automatically scrolls to the correct position to allow phases to be added as required.

HOLD Button

The HOLD button may be pressed at any time, and will temporarily suspend the active phase, maintaining the temperature at its current value until the HOLD button is again pressed, whereupon the active phase will continue from where it stopped. The START button is used to restart after a programmed HOLD phase.

Refilling the Dewar Vessel

The Cryostream Cooler Dewar Vessel can be refilled at any time by the user. Although the Cryostream Cooler can operate at atmospheric pressure, it is important that the liquid nitrogen is delivered into the Cryostream Cooler Dewar Vessel correctly.

1. Make sure the pressure in the Storage Tank being used to refill the Cryostream Cooler Dewar vessel is no greater than 2 bar.
2. The Transfer Line from the Storage Tank to the Cryostream Cooler Dewar vessel is less than 2 metres long.
3. Vent the Transfer Line to begin with to avoid spraying warm air from the Transfer Line in the Cryostream Cooler Dewar vessel. This will evaporate the liquid from the Dewar.
4. The end of the Transfer Line should not be submerged into the liquid nitrogen in the Cryostream Cooler Dewar vessel.
5. Insulate the blue "T" bar at the top of the Cryostream Cooler rigid leg from being sprayed by cold gas or liquid as the Dewar Vessel is being refilled. This can be done using a cloth or pipe insulator. The blue "T" bar contains rubber 'O' ring seals. Freezing these seals will not damage them but will cause them to leak and for the vacuum to fail.

How to Shut Down the Cryostream Cooler

To shut down the Cryostream Cooler correctly, the user should program in an END phase into the Phase Table. Program it to ramp to room temperature, when it reaches this temperature, the Cryostream Cooler will shut down. It will also mean the nozzle will be warm to help prevent moisture from the air migrating up the nozzle.

In the case of an emergency, press the red STOP button. This can also, if required, be used if the gas temperature is close to room temperature, although a programmed END maybe more convenient.

Once the Cryostream Cooler has shut down it is necessary to switch the Cryostream Controller off and on again.

In the case of an unexpected shut down, record all the information on the Status Screen before switch the Cryostream Controller off.

List of Phases

Phase	Description
RAMP	Change temperature at a controlled rate. When ramping down in temperature, if the selected rate is too fast for the Cryostream Cooler to follow, the Controller will automatically enter the RAMP / WAIT mode (this will be indicated on the screen). The effect of this is to stop the ramp in order for the gas temperature to catch up to within 5K of the gas temperature.
PLAT	Maintain temperature fixed for a certain time. The user is prompted to enter a temperature at which to plateau and to specify a time to plateau.
HOLD	Maintain temperature fixed indefinitely until the START button is pressed (a programmed HOLD should not be confused with the HOLD button)
STEP	Make a series of plateaus and ramps, each plateau being held for a certain time.
ERASE	Allow phases to be erased, one at a time, from the last one backwards, up to and including the currently active phase, which will then be replaced by a HOLD.
LOOP	Allow loops to be made from the last phase to one of the preceding ones (the head of the loop can be positioned with the arrow keys). If necessary, the program requests you to ramp back to the original temperature, in order to prevent discontinuous jumps. Four nested loops are allowed. These must be completely nested; they cannot overlap. Note that the loop number N is the number of times that the sequence within the loop will be executed. Loops can be completely "un-nested" with the ERASE option.
PURGE	This allows all of the programmed phases to be removed at once. This option will only operate when the final and current phase is a programmed HOLD. If necessary, use the ERASE option to convert the final phase into a HOLD.
SLAVE	This disables most of the front panel keys and permits the Cryostream Cooler to be controlled remotely. For more details read the section concerning the REMOTE option.
END	System shutdown. You are asked to ramp back to a final temperature and then everything is shut down. This is the controlled way to finish an experiment and should be used whenever possible.
EXIT	Exit from loading phases .

Note that not all these options will be available at any one time. The Controller will only allow those options that are possible.

Cryostream Cooler Shut Downs

The 600 Series Cryostream Controller has been designed to fully protect the Cryostream Cooler under its normal mode of operation as outlined in this manual. The control program will shut down the Cryostream Cooler if:

1. The Gas Temp or Evaporator thermometer registers an error greater than ± 25 K.
2. Gas flow drops below 2 litres/minute.
3. The Controller overheats.
4. A temperature sensor (Gas temperature or Evaporator temperature) fault occurs.
5. A Coldhead cable fault is detected.

In each case the Status Screen variables are fixed and a suitable error message is displayed.

After the Cryostream Cooler has been switched off it is advisable to leave the liquid nitrogen leg in the LN₂ Dewar (e.g. until the next day) so that the Cryopump can maintain a good vacuum while the Heat Exchanger warms up gradually. This will prevent condensation or ice forming on the blue vacuum case which may cause nuisance to surrounding equipment.

Cold start. If the Cryostream Cooler is started whilst still cold (eg. after a power interruption) the gas temperature can drop briefly, but rapidly, before proper control is established. To prevent the system shutting down due to a large error, 'Cryostream Cooler Shut Downs' (1) above is disabled for 1 minute after start-up if EvapT is less than 250K.

10 Steps to Program the Cryostream Cooler to 100K

1. Perform 'Final Checks Before Switch On'.
2. Perform a 'Warm Flow Test'.
3. Read about 'How to Switch the Cryostream Cooler On'.
4. Once the system has finished initialising, press the PROGRAM key.
5. Use the Arrow keys to select a Ramp Rate. Select a rate between 1 and 360K/hr.
6. Press ENTER to accept the Ramp Rate.
7. Press the Arrow keys to select 100K.
8. Press ENTER to accept the gas temperature of 100K.
9. Press SCREEN to revert to the Status Screen.
10. Press START to begin.

To shut down safely, see 'How to Shut Down the Cryostream Cooler'.

Adjusting the Evaporator Heater Temperature

Auto Mode

This is the default mode. On start-up, when the Cryostream Cooler Coldhead is at room temperature, EvapT will be approx 293K falling to 85K within 30 minutes.

At Gas Temperatures below 150K the value of EvapT is automatically reduced slightly to produce the extra refrigeration required.

In order to reach a Gas Temperature below 95-100K it may be necessary to allow 2+ hours running for the heat exchangers inside the Coldhead to cool down fully.

Manual Mode

To operate at a very low Gas Temperature you may need to reduce the EvapT manually - this provides the extra refrigeration required to reach the lowest temperature.

Always allow the Cryostream Cooler to run for 2+ hours before attempting this adjustment.

To select Manual Mode the EvapT must be less than 100K.

Select the Status Screen and press the EVAP key - the EVAP lamp will glow and the EvapT display will show the EvapT Set Point Value highlighted as shown below:-

88.9	Gas Temp K	Error 0.1	EvapT 81.5 K	Heat 10%
STATUS: RAMP to 85.0K @ 120K/hr (4.7)				
PROMPT: Press START to start next phase				
Press SCREEN to view phase table				

Change the EvapT set point value using the ▼ and ▲ keys and then the ENTER key - the EvapT display will change back to normal but the EVAP lamp will flash to indicate Manual Evap Mode. Reduce the EvapT by 0.1-0.2K steps and allow 5-10 mins for the change to have an effect. If the EvapT is reduced too much, liquid nitrogen droplets will form in the exit nozzle gas stream and cause temperature instability of ±0.5K or greater.

If the EVAP key is pressed during Manual Evap Mode the EvapT display will first change to AUTO, to revert to Auto Evap Mode press the ENTER key or to adjust EvapT to a new value press the EVAP key again.

Measuring the True Crystal Temperature

The absolute measurement of temperature is generally very difficult, especially in the heterogeneous environment of an open cold stream. The flow rate in the Cryostream Cooler has been designed to produce laminar flow for a few millimetres from the nozzle tip. Therefore, in order to have the crystal at a temperature close to that indicated on the Controller, we advise wherever possible to ensure that the crystal sample is within 10 mm of the nozzle.

We do not recommend measuring the temperature with a thermocouple placed in the stream. In the heterogeneous environment of a narrow cold gas stream, there are several factors that lead to spurious voltages on the thermocouple, creating errors in apparent temperature of possibly tens of degrees! For instance, conduction of heat down the wires creates a heat leak. At the point of entry of the thermocouple wires into the stream a cold junction is formed whose temperature is much lower than the room temperature assumed by the Controller, thus making the measured temperature *appear* to be much higher than indicated. Also, the sharp temperature change at the interface between the cold stream and the surrounding warm air can induce stresses into the thermocouple wires and then generate spurious EMF's. We believe that the only satisfactory way to find the error in absolute temperature at the crystal position is to calibrate with a sample that undergoes a known phase transition or change of state. For instance, we have found that the low -temperature phase transition in the langbeinite $(\text{NH}_4)_2\text{Cd}_2(\text{SO}_4)_3$ was observed from intensity measurements to be in the range 88-89K (established elsewhere to be at 88K). Similarly, lattice parameter measurements of sodium ammonium tartrate tetrahydrate gave a transition temperature in agreement to within 0.5K of the published value of 109K. A most useful compilation of transitions in hundreds of crystals has been published by P. Tomaszewski (*Phase Transitions*, **38**, 127).

Connecting the Controller to a Computer via the Remote Interface

This allows the 600 Series Controller to operate in SLAVE mode on instructions received via the REMOTE port.

The Cryostream Cooler must be started up manually in the normal way before selecting SLAVE mode. It is important to ensure that the Cryostream Cooler is functioning correctly, the dry air flow is set correctly and the liquid nitrogen is replenished regularly.

STATUS responses can be obtained from the Remote port at *any* time the 600 Series Cryostream Controller is switched on (Cryostream off, running manually or in SLAVE mode). Thus temperature and error data can be logged automatically.

Properties of the SLAVE phase

The SLAVE phase is entered into the phase table in the same manner as any other phase. However, because its final temperature is indeterminate, no phases may be added beyond a SLAVE (although an existing SLAVE may obviously be deleted in the normal way and other phases added).

When in SLAVE mode, the Controller executes a HOLD at the current set temperature until it receives a legal command request that it then executes. If another legal command request is received before the first command is complete, the first command is simply overwritten and the new one instigated. In this way running RAMPs may be replaced by HOLDS or by RAMPs with different parameters.

A SLAVE phase can be terminated either locally by pressing PROG and choosing LOCAL, or remotely by issuing a command request to leave SLAVE mode. In either case the SLAVE phase is deleted from the phase table and replaced with a HOLD at the current set temperature. The Controller is then “back to normal”, and more phases may be added and executed in the normal way - another SLAVE phase can be selected if required.

Communication

The Controller understands, and responds with, packets of the form:

Identifier <:data:data:...data:>\$

Note that all data items are surrounded by colons and the whole packet terminated by a dollar sign. Two packets are recognised at all times, namely S\$ for status request, and V\$ for version request.

The response packets have the form:

Status response: S:S/L:TS:E:TF:RR:ET:B0/1:\$

Here S is the status response identifier, the next field (i.e. the first data field) contains a single letter - either S for SLAVE mode or L for LOCAL mode, TS is the current set temperature, E the current error, TF and RR the final temperature and ramp rate of the current phase, ET is the current Evaporator Temperature and

B0/1 represents the presence of ice block messages where B0 is no ice block and B1, ice block.

Example
Send \$\$

Receive S:L:109.0:-1.2:100.0:360.0:82.5:B0:\$

This means the current gas temperature is 107.8K, and the machine is ramping to a final temperature of 100.0K at a rate of 360K/hour. The Evaporator Heater is running at 82.5K and there is no ice block present.

Version response: V:Version string:B:Baud rate:\$

Here V is the version response identifier and the other fields are self-explanatory.

When the Controller is in SLAVE mode a third type of packet is recognised - the command request.

Command request: C:R/S/H/L:<TF:RR:>\$

Here C is the command request identifier. The next field contains a single letter: R for a simple RAMP, S for a RAMP followed by a SHUTDOWN, H for HOLD at the current temperature, L for leave SLAVE mode. The other fields are meaningful only for the first two commands: TF is the final temperature and RR the ramp rate of the requested RAMP.

When a command request is received an acknowledgment will be issued with the identifier A:

Acknowledgment: A:0/1:\$

The data field contains either '0' to indicate that the packet was not a legal one and has been ignored (also issued in response to illegal packets received in LOCAL mode), or '1' to confirm receipt of a valid request which has been instigated.

Example 1
Send C:R:295.0:180.0:\$

Receive A:1:\$

This command is instructing the Cryostream to ramp to a final temperature of 295.0K at a rate of 180K/hour. The command was properly received by the Cryostream and is being executed.

Example 2
Send C:H:\$

Receive A:0:\$

This command is requesting a HOLD phase. The Controller has not received the packet correctly, or the machine is not in the SLAVE mode.

When the requested command has been completed, a completion packet with identifier D (for "done") is issued:

Completion: D:0/1:\$

The data field contains either '0' to indicate failure (SLAVE mode was terminated locally before the command was completed) or '1' for successful completion.

Remote Port

The REMOTE connection is situated on the rear panel of the 600 Series Cryostream Controller and consists of a 9-way "D" plug with pin connections as follows:

PIN No.	FUNCTION
2	Receive Data (Rc)
3	Transmit Data (Tx)
5	Signal Earth (Gnd)

N.B. The REMOTE port is a partial implementation of RS232 and some difficulty may be experienced in making the communication link work. In this case it may help to link Data Terminal Ready, Data Set Ready and Carrier Detect and also to link the Ready To Send and Clear To Send at the host RS232 end of the cable.

RS232 Settings

Baud Rate	9600
Data Bits	8
Stop Bits	1
Parity	NONE

Intercharacter Delay

When sending a stream of information in ASCII format, it is usual to insert a delay between the subsequent characters to allow time for them to be processed. The Cryostream Controller requires a 300ms intercharacter delay to allow reliable reception.

Note:

The REMOTE port may be tested with the 600 Series Cryostream Controller switched on but the Cryostream Cooler not running - send a version request (V\$) or a status request (S\$) to evoke the correct output from the 600 Series Cryostream Controller. From windows, the applications "Terminal" or "HyperTerminal" can be used to set up an ASCII link via the COM ports. Open a channel directly to the port and configure it with the above settings. Characters can be sent by entering them directly into the console.

Chart Output

The Chart Output of the 600 Series Cryostream Controller gives a continuous analogue signal proportional to the Error display. Error is the difference between the required gas temperature and measured Gas Temp.

The signal level is ± 5 Volts D.C that represents an Error of ± 5 K.

Connection is to two 4mm sockets on the rear panel. A Digital-to-Analogue Converter is used for this output so that the signal varies in steps of 19.5mV or approximately 0.02K. The Chart Output has an impedance of 1K Ω and is short-circuit protected.

Pumping Down the Vacuum Space in the Cryostream Cooler

From time to time you may need to repump the vacuum insulation space of the Cryostream Cooler Coldhead (the blue can). This will be apparent when the outside of the Coldhead becomes excessively cold or wet all over during operation or the Cryostream Cooler is unable to reach the required gas temperature and the Heat% valve is zero.

Do not be misled by similar symptoms that are not due to a vacuum problem. For instance, an incorrect setting of the Evaporator could cause the end flange of the Coldhead (where the electrical and gas connections emerge) to become icy. Similarly, if the liquid nitrogen supply runs low or when the nitrogen leg is removed from the storage vessel the operation of the built-in cryopump is defeated and the Coldhead may become cold or damp externally.

It has been established that the Cryostream Cooler vacuum can be repumped using a good rotary vacuum pump (with air ballast valve), a Pirani gauge and the CRH25 Reactivation Heater. It is not necessary to use a diffusion pump.

The correct procedure is as follows:

1. Determine that the unit really does require repumping as described above (see Troubleshooting Guide or contact Oxford Cryosystems or your local agent if you are unsure.)
2. Switch the Cryostream Cooler off and leave it standing for 24 hours. This will allow it to warm up internally.
3. Take the rigid section of the transfer line out of the storage vessel. Leave the rigid leg to warm up for an hour and then dry it carefully.
4. Place the end of the nitrogen leg into the hole in the hot block of the CRH25 heater. Ensure that nothing else can come into contact with the heater to cause damage. Do not switch the heater on at this stage.
5. Connect a good rotary pump (preferably 2-stage) to the Cryostream Cooler Pump-out Port using the Pumping Adaptor (see picture below) supplied. Screw the adaptor onto the Pumpout Port positioned at the top of the rigid leg of the transfer line.

Do not withdraw the sealing plug at this stage.

Attaching the Pumping Adaptor

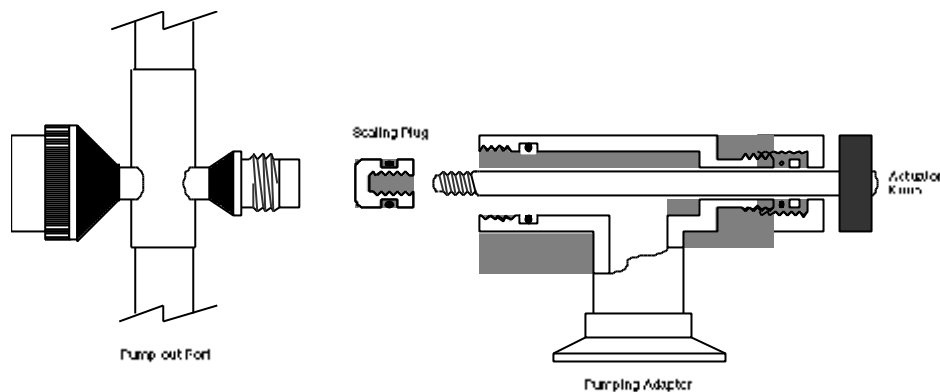

6. Start the rotary pump and ensure that a pressure of 0.1 mbar can be obtained up to the pumping adaptor. It may be necessary to run the pump with its air ballast valve open for about 30 minutes.
7. When the rotary pump pressure is 0.1mbar, use the Pumping Adaptor Actuator Knob to locate and withdraw the Sealing Plug very slowly to avoid a rush of gas. An extra valve in the pumping line would help in this operation.
8. Wait until the pressure falls towards 0.1mbar - this may take 60 minutes. If necessary, use the rotary pump air ballast again. If you cannot obtain a sufficiently low pressure at this stage you may have a leak (or bad pump!) which should be investigated. Contact your Cryostream Cooler supplier if all else fails.
9. When a pressure near to 0.1mbar is obtained, the CRH25 reactivation heater can be switched on. The heater raises the temperature of the cryopump situated in the bottom of the nitrogen leg to 150-200°C in order to drive off water and other condensable vapours. This is likely to cause the vacuum space pressure to rise and it may well be necessary to use the rotary pump air ballast yet again to purge the pump of these condensables.
10. The vacuum should be pumped and baked for approximately 6 hours. The final pressure should be 0.01mbar (or better) with a 2-stage rotary pump.
11. To finish pumping and baking, the Sealing Plug should be pushed back in using the Actuator Knob of the Pumping Adaptor.

This must be done whilst the CRH25 heater is still hot.
12. Switch the CRH25 heater off immediately and allow to cool. Unscrew the Actuator Knob from the Sealing Plug and remove the Pumping Port Adaptor. Replace the Pumping Port Cover.

The Cryostream Cooler Diaphragm Pump

Diaphragm Pump

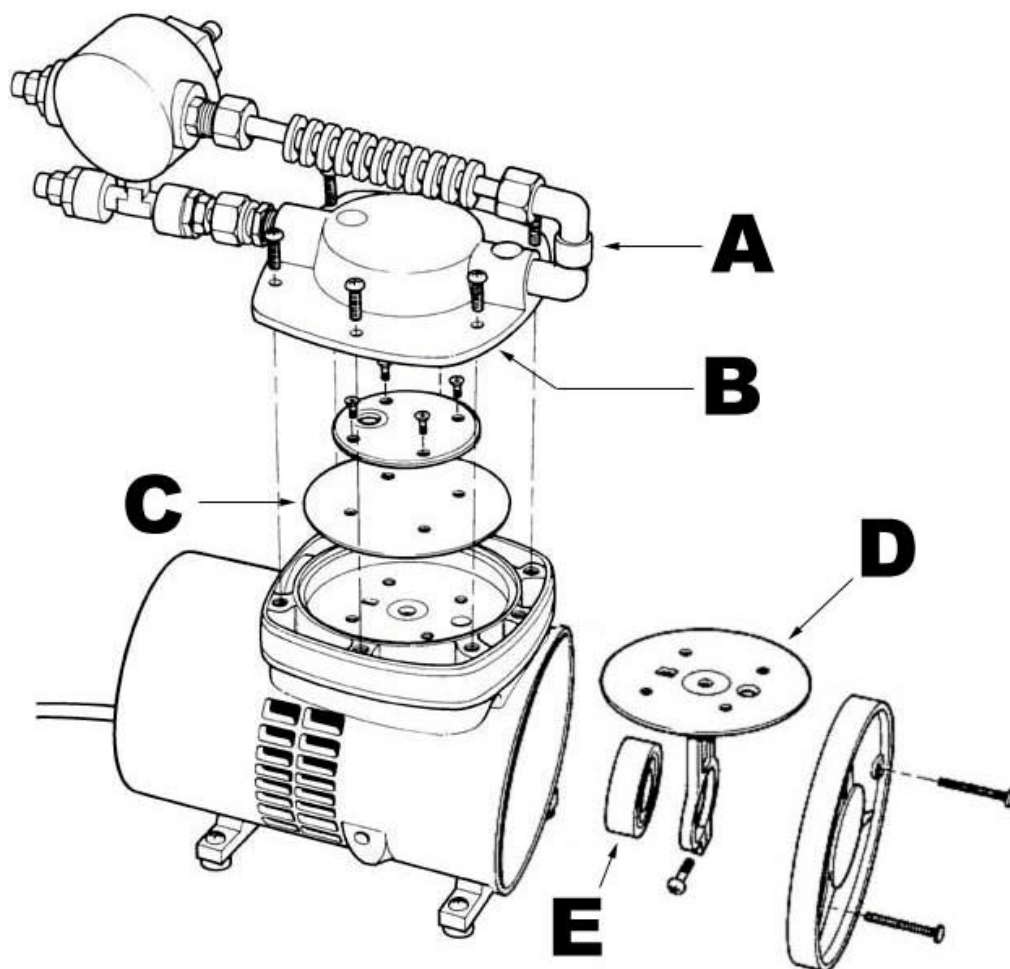

Part	Description
A	Cylinder Head
B	Valve Flapper
C	Diaphragm
D	Connecting Rod Assembly
E	Pump Bearing

Cryostream Cooler Service

The Cryostream Cooler has been designed to be as easy to use as possible and should run without the need for constant attention, once the user is accustomed to the system. However, there are some important points to look out for:

1. If the outer blue case of the Cryostream Coldhead becomes wet or frosty, this probably indicates a loss of vacuum. The Gas Temperature may also be higher than the Set Temperature and it may be necessary to decrease the Evaporator power in order to maintain temperature. The lower the required temperature, the more important the vacuum becomes. The remedy is to pump out the system as described in Pumping 'Down the Vacuum Space in the Cryostream Cooler'.
2. Always make sure all the nylon tubes are pushed firmly into each of their Quick-Fit connectors. Each tube should fit in 15-16mm. Make sure that none of the tubes are strained to one side, this can sometimes cause a leak in an otherwise reliable vacuum connector. Regularly trimming these tubes will help keep them seated correctly.
3. Regular maintenance of the Line Drier Units are recommended as they will become saturated with ice from the nitrogen supply. Use of, and instructions for maintaining the Line Driers can be found in the section 'Stainless Steel Line Drier Units'.
4. The Cryostream Cooler Diaphragm Pump contains a rubber diaphragm. This diaphragm is designed to last 10000 hours of running. Possible symptoms of a diaphragm failure can be found in the Troubleshooting Guide. Do not rush to change this diaphragm as failure to replace it properly can result in the introduction of gas leaks.
5. The AD41 Dry Air Unit (optionally supplied for use as a dry air supply) has a service interval of 10000 hours. The Counter on the front of the AD41 indicates when this system needs servicing. If demand on the AD41 is high, plan to service the AD41 before it fails at a time that is convenient. Instructions for servicing the AD41 are in its manual. An AD41 Service Kit can be obtained from Oxford Cryosystems or a local Cryostream Cooler agent.

Liquid and Gaseous Nitrogen Safety Sheet

General

These safety points are a guideline to outline the potential hazards and procedures involved in the handling of liquid or gaseous nitrogen. Anyone handling liquid or gaseous nitrogen should first inform their departmental or laboratory safety advisor and receive advice about local safety procedures.

All users are requested to read this safety sheet before handling the Cryostream Cooler. Oxford Cryosystems accept no responsibility for injury or damage caused by the mishandling of liquid or gaseous nitrogen.

General Properties

1. Gaseous nitrogen is colourless, odourless and tasteless and is slightly lighter than air at equal temperatures; cold nitrogen vapour is, however, denser than atmospheric air.
2. Liquid nitrogen is odourless, colourless and boils at -195.8°C . One volume of liquid nitrogen gives approximately 700 volumes of gas at ambient conditions.
3. Nitrogen is not flammable. It is chemically inert, except at high temperatures and pressures. Its volume concentration in air is 78%.
4. Liquid and cold gaseous nitrogen can cause severe burns or frostbite when in contact with the skin or respiratory tract.
5. Gaseous and liquid nitrogen is non-corrosive.
6. Nitrogen does not support life and acts as an asphyxiant.
7. Nitrogen is intrinsically non-toxic.

Fire and Explosion Hazards

Gaseous and liquid nitrogen are flammable and do not on themselves constitute a fire or explosion risk. However, both gaseous and liquid nitrogen are normally stored under pressure and the storage vessels whether gas cylinders or liquid tanks, should not be located in areas where there is a high risk of fire or where they may normally be exposed to excessive heat.

Health Hazards

Asphyxia

Nitrogen, although non-toxic, can constitute an asphyxiation hazard through the displacement of the oxygen in the atmosphere. Nitrogen gas nor oxygen depletion are detectable by the normal human senses.

Oxygen is necessary to support life and its volume concentration in the atmosphere is 21%. At normal atmospheric pressure persons may be exposed to oxygen concentrations of 18% or even less, without adverse effects. However, the response of individuals to oxygen deprivation varies appreciably. The minimum oxygen content of breathing atmospheres should be 18% by volume but to ensure a wider margin of operational safety it is recommended that persons are not

exposed to atmospheres in which the oxygen concentration is, or may become, less than 20% by volume.

Symptoms of oxygen deprivation, such as increased pulse and rate of breathing, fatigue, and abnormal perceptions or responses, may be apparent at an oxygen concentration of 16%.

Permanent brain damage or death may arise from breathing atmospheres containing less than 10% oxygen. Initial symptoms will include nausea, vomiting and gasping respiration. Persons exposed to such atmospheres may be unable to help themselves or warn others of their predicament. The symptoms are an inadequate warning of the hazard. BREATHING A PURE NITROGEN ATMOSPHERE WILL PRODUCE IMMEDIATE LOSS OF CONSCIOUSNESS AND ALMOST IMMEDIATE DEATH.

Cold Burns

Liquid and cold nitrogen vapours or gases can produce effects on the skin similar to a burn. Naked parts of the body coming into contact with uninsulated parts of equipment may also stick fast (as all available moisture is frozen) and the flesh may be torn on removal.

Frostbite

Severe or prolonged exposure to cold nitrogen vapour or gases can cause frostbite. Local pain usually gives warning of freezing but sometimes no pain is experienced. Frozen tissues are painless and appear waxy with a pallid yellowish colour. Thawing of the frozen tissues can cause intensive pain. Shock may also occur if the burns are at all extensive.

Effect of Cold on Lungs

Prolonged breathing of extremely cold atmospheres may damage the lungs.

Hypothermia

Low environmental temperatures can cause hypothermia and all persons at risk should wear warm clothing. Hypothermia is possible in any environmental temperature below 10°C but susceptibility depends on time, temperature and the individual. Older persons are more likely to be affected. Individuals suffering from hypothermia may find that their physical and mental reactions are adversely affected.

Precautions

Operations and Maintenance

It is essential that operations involving the use of gaseous or liquid nitrogen particularly where large quantities are used, are conducted in well-ventilated areas to prevent the formation of oxygen deficient atmospheres.

Ideally, nitrogen should be vented into the open air well away from areas frequented by personnel. It should never be released or vented into enclosed areas or buildings where the ventilation is inadequate. Cold nitrogen vapours are denser than air and can accumulate in low lying areas such as pits and trenches.

Where large spills of liquid nitrogen occur, a fog forms in the vicinity of the spill caused by the condensation of water vapour in the surrounding air. The fog, in addition to severely reducing visibility may contain oxygen concentrations appreciably lower than that of the air presenting a local asphyxiation hazard.

Personnel Protection

Persons handling equipment in service with liquid nitrogen should wear protective face shields, loose fitting gauntlets and safety footwear.

Emergencies

In the event of an accident or emergency the instructions below should be implemented without delay.

Asphyxiation

Persons showing symptoms of oxygen deprivation should be moved immediately to a normal atmosphere. Persons who are unconscious or not breathing must receive immediate first aid. Medical assistance should be summoned without delay. First aid measures included inspection of the victim's airway for obstruction, artificial respiration and simultaneous administration of oxygen. **THESE PROCEDURES SHOULD ONLY BE CARRIED OUT BY TRAINED FIRST AID STAFF.** The victim should be kept warm and resting.

It is important that the personnel carrying out rescue operations should minimise the risk to themselves.

Treatment of Cold Burns and Frostbite

Cold burns should receive medical attention as quickly as possible. However, such injuries are not an everyday occurrence and doctors, hospital staff or works first aid personnel may not be aware of the basic methods of treatment. The following notes describe the first aid treatment and recommended advice for further treatment to be given by a medical practitioner or a hospital.

First Aid

In severe cases summon medical attention immediately. Flush affected areas of skin with copious quantities of tepid water to reduce freezing of tissue. Loosen any clothing that may restrict blood circulation. Move the victim to a warm place but not to a hot environment and do not apply direct heat to the affected parts. Every effort should be made to protect frozen parts from infection and further injury. Dry, sterilised bulky dressings may be used but should not be applied so tightly that blood circulation is restricted.

Treatment by Medical Practitioner or Hospital

1. Remove any clothing that may constrict the circulation to the frozen area. Remove patient to sick bay or hospital.
2. Immediately place the part of the body exposed to the cryogenic material in a water bath which has a temperature of not less than 40° C but no more than 45°C. **NEVER USE DRY HEAT OR HOT WATER.** Temperatures in excess of 45°C will superimpose a burn upon the frozen tissue.
3. If there has been a massive exposure to the super cooled material so that the general body temperature is depressed, the patient must be re-warmed gradually. Shock may occur during re-warming, especially if this is rapid.

4. Frozen tissues are painless and appear waxy with a pallid yellowish colour. They become painful, swollen and very prone to infection when thawed. Therefore, do not re-warm rapidly if the accident occurs in the field and the patient cannot be transported to hospital immediately. Thawing may take from 15-60 minutes and should be continued until the blue, pale colour of the skin turns to pink or red. Morphine, or some potent analgesic, is required to control the pain during thawing and should be administered under professional medical supervision.
5. If the frozen part of the body has thawed by the time medical attention has been obtained, not re-warm. Under these circumstances cover the area with dry sterile dressings with a large bulky protective covering.
6. Administer a tetanus booster after hospitalisation.

Hypothermia

Persons suspected to be suffering from hypothermia should be wrapped in blankets and moved to a warm place. Slow restoration of temperature is necessary and forms of locally applied heat should not be used. Summon medical attention.

Liquid Nitrogen Spillage

If large spills of liquid nitrogen spillage occur, large quantities of water should be used to increase the rate of liquid vaporisation.

Cryostream Cooler Troubleshooting Guide

Very important guidelines for using this document

1. This guide is designed for operators responsible for looking after Cryostream Coolers and have, at least, some experience of them. It is aimed at users of the 600 Series Cryostream Cooler.
2. This guide is not designed to cover every technical eventuality but to provide the correct interpretation of, and solution to, a variety of common symptoms. As a user, symptoms may arise that are not covered here. If, at any time, you are unsure of the cause of the Cryostream Cooler problem, contact your local agent or Oxford Cryosystems directly.
3. If you experience a shutdown or unusual behaviour from your system, please record as much information as possible including GasT, Error, EvapT, Heat%, gas flow rate from the flowmeter and any physical symptoms you feel are a concern. Then contact Oxford Cryosystems or your local agent.
4. DO NOT rush into changing components or fixing something until you have spoken to Oxford Cryosystems (remember technical support and advice are free of charge) or your local agent. Changing components can VERY OFTEN create more problems and mask the original fault.

Condensation and/or ice covering the outside of the blue Coldhead or the flexible transfer line

Cause

Condensation and/or ice over the outside of the Cryostream Cooler transfer line or blue can indicates a loss of vacuum. This should not be confused with localised spots of ice or condensation. Remember, it's impossible to lose a vacuum from one small area of vacuum space! This loss of vacuum can be for two reasons:

1. Natural out-gassing over a period time depending on the physical treatment of the Coldhead.
2. If these symptoms arise more frequently than twice a year, there is a chance the Pumpout Port and Relief Valve under the two blue dust caps at the top of the rigid section of the transfer leg may be freezing during refilling of the Dewar. These ports contain rubber O-rings that can harden and leak when sprayed with cold gas or liquid. This freezing will not permanently damage the O-rings as they will defrost, but it will cause them to leak.
3. Vacuum leak at an internal or external joint or cracked flexible line, although this is rare.

Solution

Consult the instruction manual on repumping the vacuum and be sure to protect the Pumpout Port and Relief Valve when refilling.

If it is believed there is a leaky joint or cracked flexible hose, contact Oxford Cryosystems or your local agent as this is not user serviceable.

Associated Symptoms

Inability to reach low temperatures and the base temperature begins to rise

Localised ice spot on the flexible line

Cause

This is due to the flexible line being bent too sharply beyond its 200mm minimum radius so that the transfer capillary inside the flexible vacuum jacket touches the wall of the vacuum jacket.

Solution

The Cryostream Cooler will continue to run happily like this, but it may be worth contacting Oxford Cryosystems or your local agent. Try to increase the bend radius at the point where the ice spot occurs.

Localised icing on the Coldhead SUCT connector and tubing

Cause

This is due to an imbalance in the heat exchanger inside the Coldhead of the Cryostream Cooler.

The Cryostream Cooler requires 5 litres/minute of gas along both paths of its heat exchanger so that the 5 litres of gas in the SUCT path can absorb the heat from the 5 litres of gas in the FLOW path. If gas has leaked out between the gas exiting the SUCT side of the heat exchanger (SUCT connector on the top of the Coldhead,) and entering the FLOW side of the heat exchanger (FLOW connector on the top of the Coldhead,) excess cold gas spills out into the nylon tubing in the SUCT connector causing condensation and icing.

Solution

Check to make sure all the nylon tubing is pushed 15-16mm into each quick-fit connector on the Cryostream Cooler and then perform the Nitrogen Circuit Gas Leak Test . Run the system again and if the problem persists, contact Oxford Cryosystems or your local agent of your findings.

Associated Symptoms

Unstable gas temperature

Spitting of liquid nitrogen from the nozzle

Localised ice formation around the neck of the Dewar and the Cryostream Cooler leg

Cause

If the Dewar is open to the atmosphere, it is common for ice to build up at the interface between the warm air and the cold gas emanating from the Dewar. This ice can fall into the Dewar and contaminate the nitrogen as its concentration builds up.

Solution

Find a way to cover the Dewar opening. This can be done quite comprehensively but **BE SURE NOT TO SEAL THE DEWAR**. Simply plugging the Dewar with a cloth will prevent most atmospheric moisture getting into the Dewar, but more

elaborate setups involve clamping a bung on to the top of the Dewar and then drilling holes for the Cryostream Cooler leg, venting and refilling. If the Dewar is sealed up, a vent hole is VERY important otherwise the Cryostream Cooler will NOT work.

Associated Symptoms

Controller Status reads 'Ice Block warning will trip at 2 l/min'

Cryostream Cooler Shutdown due to ice block

Cryostream Cooler Shutdown due to low flow after a few seconds of running

Cryostream Cooler Shutdown due to low flow - no explicable reason

Inability to reach low temperatures

Cause

If the gas temperature will not drop below a certain temperature, (for example, the programmed gas temperature is 100K and the Cryostream Cooler will only reach 105K but is stable and not rising,) there are two possible causes:

1. The Evaporator Heater setting is too high. This is usually only the case when the required temperature is below about 95K.
2. If the minimum gas temperature has been rising over a period of time and it is not possible to reach the required temperature, the vacuum may be failing.

Solution

Manually adjust your Evaporator setting. Please see your manual for this procedure. If the base gas temperature that the Cryostream Cooler reaches continues to rise, it is likely that the vacuum is degrading and will require repumping. See the manual for this procedure.

Associated Symptoms

Condensation and/or ice covering the outside of the blue Coldhead or the flexible transfer line

Inability to reach low temperatures and the base temperature begins to rise

Cryostream Cooler maintains an error of a few degrees that disappears when the Dewar is topped up

Inability to reach low temperatures and the base temperature begins to rise

Cause

These symptoms indicate a loss of vacuum. This loss of vacuum can be for two reasons:

1. Natural out gassing over a period time depending on the physical treatment of the Coldhead.
2. If these symptoms arise more frequently than twice a year, there is a chance the Pumpout Port and Relief Valve under the two blue dust caps at the top of the rigid section of the transfer leg may be freezing

during refilling of the Dewar. These ports contain rubber O-rings that will turn to glass when sprayed with cold gas or liquid. This freezing will not permanently damage the O-rings as they will defrost, but it will cause them to leak.

Solution

Repump the vacuum and be sure to protect the Pumpout Port and Relief Valve when refilling the Dewar with nitrogen.

Associated Symptoms

Condensation and/or ice covering the outside of the blue Coldhead or the flexible transfer line

Inability to reach low temperatures

Controller Status reads 'Ice Block warning will trip at 2 l/min'

Cause

The Cryostream Cooler has detected the beginnings of an ice block inside the Coldhead. The ice block is detected by a pressure switch in the Controller and is designed to give the user an advance warning of an ice block that will eventually cause the system to trip.

This is due to a build up of ice in the FLOW path capillary of the heat exchanger. The water vapour in the nitrogen gas freezes out onto the wall of the capillary of the heat exchanger and eventually blocks it. It is not blocked by large particles of ice by the slow narrowing of the capillary wall as the water vapour freezes out. If the Cryostream Cooler has been running well up to this point, it may continue to run for long enough to finish a data collection. The next symptom to be seen is a gradual fall in the nitrogen gas flow rate.

There are two possible sources for the water vapour:

1. Ice in the nitrogen supply - small particles of ice are sucked up the leg and flexible transfer line into the Coldhead. These particles pass through the Evaporator Heater and along the SUCT path of the heat exchanger. The ice then passes out of the Coldhead along the tubing marked SUCT, through the Controller, through the pump, back through the Controller and back into the Coldhead along the tubing marked FLOW or DEL. During its course along the nylon tubing, the ice melts to water vapour which, on entry into the FLOW path of the heat exchanger, refreezes causing narrowing of the capillary and an impending ice block. ICE PARTICLES DO NOT CAUSE THE BLOCK, WATER VAPOUR THAT FREEZES CAUSES THE BLOCK.

Note:

There is no easy way of completely removing particles of ice from your nitrogen supply. This means you will get this warning eventually, so do not panic!!

2. An inward leak - Atmospheric moisture is sucked into the gas stream on the SUCT path of the gas flow circuit at some point. The likely cause of this is a nylon tube NOT pushed its full 15-16mm into the quick-fit connector. If all the tubing has been resealed properly, it is possible the diaphragm in the Diaphragm Pump has split.

Solution

First, to remove the ice block, let your system warm up over night. The EvapT value on the Controller must reach room temperature as this indicates that the ice block has melted. When the system is restarted, the water vapour will blow, unnoticed, out of the end of the nozzle. If the Cryostream Cooler is required for use and it can not be left over night, disconnect the dry air supply for the Cryostream Cooler at the top of the nozzle and reconnect it to the FLOW connector on the top of the Coldhead. IMPORTANT: Reduce the flow on the dry air supply to 5 litres/minute to avoid any damage to the Gas Sensor in the nozzle. The dry air should be left running for a few hours until the EvapT value on the Controller reaches room temperature, this will blow out all the water vapour. Once this process has finished, reconnect all the tubing.

Ice in your nitrogen supply - empty the Dewar vessel and let it warm up to room temperature. Mop up any moisture in the bottom. Check on the purity of your liquid nitrogen by shining a flashlight into the Dewar. The liquid should look clean like water but do not worry if you see a few particles in the bottom, as this is fairly normal. If your liquid nitrogen is milky, you have a chronic contamination of ice, the Cryostream Cooler can not handle this so talk to your liquid nitrogen supplier. Try to avoid pushing the rigid leg of the Cryostream Cooler into the bottom of the Dewar, this prevents particles in the bottom of the Dewar being sucked up the leg. Dewars that are continually topped up should be emptied and cleaned out at least every three months, more often if possible.

An inward leak - Check to make sure all the nylon tubing is pushed 15-16mm into each quick-fit connector. It is worth marking each tube with a marker pen to be sure that each tube is seated correctly. Perform the Nitrogen Circuit Gas Leak Test and inform Oxford Cryosystems or your local agent of your findings. Do not rush into changing a diaphragm as opening up the Diaphragm Pump can often cause a leak. The diaphragm in the grey Diaphragm Pump will last for approximately one year of continuous running. Speak to Oxford Cryosystems first.

Once the ice contamination problem has been rectified, fit an Oxford Cryosystems Line Drier Unit. If there is already one in circuit, it will now be contaminated and will require reactivation (see instructions). DO NOT fit a new one or a reactivated one until you have rectified the ice contamination. You will create unnecessary work and confusion for yourself.

Associated Symptoms

Cryostream Cooler Shutdown due to ice block

Ice formation on the sample

Cause

Ice formation on the sample can begin at the point of flash cooling the sample or it can build up over time to eventually cover the sample and thus ruin the diffraction image.

Note:

Ice on the sample does not come from the nitrogen gas travelling down the nozzle. Nitrogen gas from the Cryostream Cooler is very dry (circa 0.1ppm of water vapour).

Ice on the thin film supporting the crystal in the loop can arise from a number of sources.

1. Insufficient cryoprotection of the buffer solution.
 - a. Too much mother liquor results in dilution of the cryoprotectant to the point where it is no longer adequate.
 - b. A thick film around the crystal may result in a larger thermal mass that must then be cooled.
2. Rate of flash cooling is too slow.
3. The sample is too far away from the nozzle or not aligned in the centre of the cold stream. The cold stream and the dry air stream mix and draw in atmospheric moisture that is frozen out on the sample.
4. The loop is unclean. Any particles on the loop will propagate ice formation.
5. A wet dry air supply or a disturbance of the laminar flow system due to drafts in your laboratory or an oversized sample mount (ie capillary or pin is too thick).
6. It is important that the velocities of the two gases are the same. If they are grossly unmatched, atmospheric moisture will encroach the streams and cause ice to build up. A true laminar flow will prevent attack from atmospheric moisture.

Solution

To increase the effectiveness of the cryoprotectant, increase its concentration.

Position the nozzle as close to the sample as possible without affecting the path of the x-rays or casting an image on to the detector. The ideal position is inside the first 6mm from the end of the nozzle and the centre 2mm cross section. Be sure to clean the loop before use as ice build up will only compound the problem.

Check the laboratory for drafts. The most likely cause of turbulence is an air conditioning unit, a cooling fan from an x-ray generator or the rotating anode generator. Create a screen between the source of the draft and your cold stream. This will greatly reduce the turbulence. If you are unsure of the source of the draft, try the Flashlight Test.

Try adjusting the flow of the outer dry gas stream. In a draft-free environment 7-8 litres per minute is fine, but when the air is more turbulent, try turning the outer

stream flow rate up to 12 or 13 litres per minute; this can often cure the problem. (See Flashlight Test)

If the icing persists and there is also a concentric build up of ice on the nozzle, the most likely cause is a wet dry air supply. If you have an Oxford Cryosystems Dry Air Unit, change the Compressor Filter Delivery Element. If the icing persists, contact Oxford Cryosystems or your local agent about a Dry Air Unit service.

Associated Symptoms

Concentric formation of ice around the nozzle

Feather of ice forming from inside the cold stream nozzle and extending towards sample

Feather of ice forming from inside the cold stream nozzle and extending towards sample

Cause

An ice build up of this type is caused by a disturbance of the laminar flow system where the cold stream mixes with the outer dry air stream and atmospheric moisture. This is due to drafts in the laboratory or a foreign body in the Cryostream Cooler nozzle.

Solution

Check the laboratory for drafts. The most likely cause of turbulence is an air conditioning unit, a cooling fan from an x-ray generator or the rotating anode generator. Create a screen between the source of the draft and your cold stream. This will greatly reduce the turbulence. If you are unsure of the source of the draft, try the Flashlight Test.

Try adjusting the outer dry gas stream. In a draft-free environment 7-8 litres/minute is fine but when the air is more turbulent, try turning the outer stream flow rate up to 12 or 13 litres per minute; this can often cure the problem. (See Flashlight Test)

If the ice build up continues, look carefully up the nozzle to make sure there are no obvious foreign bodies disturbing the laminar flow system (eg. blob of solder or modelling clay). If there is, contact Oxford Cryosystems or your local agent, immediately; **DO NOT TRY TO REMOVE THE OBJECT WITHOUT SPEAKING TO US FIRST**. Damage to the Gas Sensor is expensive and time consuming to fix.

Associated Symptoms

Ice formation on the sample

Concentric formation of ice around the nozzle

Ice formation on outer edge of the nitrogen gas cold stream nozzle

Ice formation on outer edge of the nitrogen gas cold stream nozzle

Cause

The likely cause of ice on one side only of the nitrogen nozzle is a misaligned dry air shroud tube. This is not the same as a feather of ice growing from inside the cold nitrogen gas nozzle.

Solution

Look up the nozzle of the Cryostream Cooler and check to make sure the outer dry air shroud is concentric with the inner nitrogen nozzle. A small misalignment may be corrected by pushing the inner nozzle to one side. The shroud tube is locked into its 26mm diameter mounting bush using a low strength retainer compound (eg Loctite 222e). To release the shroud tube, grasp it gently and push to one side to release the retainer bond. Movement of the shroud tube will be limited as it touches the outside of the inner nitrogen nozzle - this prevents the shroud tube from kinking. Once the outer dry air shroud has been removed, refit the shroud tube using a little retainer compound, check that the tube is concentric and allow the retainer to set.

Associated Symptoms

Feather of ice forming from inside the cold stream nozzle and extending towards sample

Concentric formation of ice around the nozzle

Cause

This is likely to be wet air from the dry air supply or a high flow rate from the dry air supply. The cold stream requires a dry air shroud of dewpoint -60°C . If the stream is wet, the moisture in the air will freeze onto the nozzle and sample.

Solution

Make sure an unruly student has not turned the flow rate up to 25 litres/minute!! If the Cryostream Cooler utilises an Oxford Cryosystems AD31 Dry Air Unit, change the Compressor Delivery Filter Element; a spare is provided. If the ice persists, contact Oxford Cryosystems or your local agent who will supply a service kit.

Associated Symptoms

Ice formation on the sample

Feather of ice forming from inside the cold stream nozzle and extending towards sample

Ice formation on outer edge of the nitrogen gas cold stream nozzle

Spitting of liquid nitrogen from the nozzle

Cause

Spitting of liquid nitrogen is caused by recondensation of nitrogen gas in the FLOW path of the heat exchanger. This can be caused by a number of factors:

1. The gas flowing through the heat exchanger in the Coldhead is unbalanced. The amount of gas flowing through the SUCTION path of the heat exchanger is greater than the amount of gas flowing along the FLOW path. This causes the gas in the FLOW path to get too cold and recondense. This is commonly due to an outward gas leak.

2. The Evaporator heater is set too low. If the Evaporator has been adjusted to a lower setting, there is more cooling in the heat exchanger than is required. This causes recondensation of nitrogen in the FLOW path and liquid nitrogen is spat out of the nozzle.
3. The Coldhead is angled too close to horizontal. The Cryostream Cooler relies a little on gravity so that any condensed liquid nitrogen can run unnoticed from the nozzle. If the Coldhead is running horizontally or upward, there is often a small build up of pressure behind droplets of liquid nitrogen that are then spat from the heat exchanger out of the nozzle.

Solution

It is worth considering these solutions in order:

1. Adjust the angle of your Coldhead to greater than 10° from the horizontal.
2. Increase your Evaporator setting until the spitting has stopped. (600 Series Users: If you are running at around 90K your Heat% value should be no more than a 2-5%.)
3. Check to make sure all the nylon tubing is pushed 15-16mm into each quick-fit connector then perform the Nitrogen Circuit Gas Leak Test and contact Oxford Cryosystems or your local agent with your findings.

Associated Symptoms

Localised icing on the Coldhead SUCT connector and tubing

Unstable gas temperature

Unstable gas temperature

Cause

There are a couple of possible causes of an unstable gas temperature:

1. When the Cryostream Cooler experiences recondensation of nitrogen in its heat exchanger the liquid spits down the nozzle and hits the Gas Heater and Gas Sensor causing the temperature to jump around as it reacts to keep the temperature stable. This will also be associated with a fluctuation in the Heater power (Heat%). This imbalance in the heat exchangers can be caused by an outward gas leak or an Evaporator Heater set too low.
2. The Gas Sensor in the Cryostream Cooler nozzle is misaligned.
3. If after months of use, the Cryostream Cooler starts to lose its vacuum insulation, then it will struggle to maintain its base temperature and the gas temperature error will increase, positively.

Solution

It is worth considering these solutions in order:

1. Increase your Evaporator setting by a few tenths of a degree at a time until the spitting has stopped. (600 Series Users: If you are running at around 90K your Heat% value should be typically 5-7%).
2. Look up the end of the nozzle. The Gas Sensor is a small chip that lies in the gas stream. It is possible to just make out the edge of it if you look carefully. DO NOT, UNDER ANY CIRCUMSTANCES, TOUCH THIS SENSOR. IT CAN BE EASILY DAMAGED AND IS EXPENSIVE TO FIX. If the sensor is not in the centre of the stream, the temperature will jump around, as it is not seeing the true gas temperature. Contact Oxford Cryosystems who will be able to fix the problem.
3. If you suspect an outward gas leak, check to make sure all the nylon tubing is pushed 15-16mm into each quick-fit connector then perform the Nitrogen Circuit Gas Leak Test and contact Oxford Cryosystems or your local agent with your findings.
4. As a very last resort, repump your vacuum insulation in accordance with the instructions in the manual.

Associated Symptoms

Condensation and/or ice covering the outside of the blue Coldhead or the flexible transfer line

Spitting of liquid nitrogen from the nozzle

Localised icing on the Coldhead SUCT connector and tubing

Inability to reach low temperatures and the base temperature begins to rise

Cryostream Cooler maintains an error of a few degrees that disappears when the Dewar is topped up

Cause

In the bottom five inches of the Cryostream Cooler transfer leg there is a Cryopump. This maintains the vacuum in the Cryostream Cooler when the leg is plunged into liquid nitrogen. If the nitrogen level gets sufficiently low to uncover the Cryopump, the vacuum insulation can be weakened to cause the gas temperature to rise.

Solution

Top up the Dewar. If the Dewar is fitted with a level detector, make sure it is set up to refill before the Cryopump is exposed.

Cryostream Cooler Shutdown due to low flow after a few seconds of running

Cause

If, after a few seconds of running the pump can not generate any gas flow the system will shut down. The most likely cause of this is a restriction in the transfer line from the Dewar caused by a solid piece of matter (usually ice) restricting the flow of liquid nitrogen.

Solution

Take the leg out of the Dewar vessel. Wait 15 minutes for the end of the leg to warm up to room temperature. Disconnect the dry air shroud gas from its connector at the top of the nozzle and reconnect it to the SUCT connector on top of the Coldhead. Set the gas flow to about 5 litres/minute. This will blow air down the Cryostream Cooler transfer line and will both remove any solid matter or ice from the line and dry it out. This should be done for about half an hour until the leg has warmed up. Once the block is cleared reconnect the tubing to its correct connectors.

Associated Symptoms

Cryostream Cooler Shutdown due to low flow - no explicable reason

Cryostream Cooler Shutdown due to low flow - no explicable reason

Cause

There are two possible causes the Cryostream Cooler can not diagnose itself:

1. A restriction in transfer line from the Dewar caused by a solid piece of matter (usually ice) restricting the flow of liquid nitrogen.
2. The optical Gas Flow Sensor in the flowmeter has been subjected to a source of infra red light which will fool it and cause the Cryostream Cooler to trip.

Solution

1. 1. Wait for the Cryostream Cooler to warm up over a few hours (EvapT must reach room temperature) then take the leg out of the Dewar vessel. Disconnect the dry air shroud gas from its connector at the top of the nozzle and reconnect it to the SUCT connector on top of the Coldhead. Set the gas flow to about 5 litres/minute. This will blow air down the Cryostream Cooler transfer line and will both remove any solid matter or ice from the line and dry it out. **DO NOT CONNECT THIS DRY AIR SUPPLY TO THE FLOW PATH WITH A FLOW RATE OF >5 LITRES/MINUTE. THIS MAY DAMAGE THE GAS SENSOR IN THE NOZZLE.**
2. 2. Make sure the front panel of the Cryostream Cooler is not facing a window or a bright light. Turn it away from the light source.

Associated Symptoms

Cryostream Cooler Shutdown due to low flow after a few seconds of running

Cryostream Cooler Shutdown due to ice block

Cause

This is due to a build up of ice in the FLOW side of the heat exchanger. This ice has come from water vapour frozen out on the wall of the capillary of the heat exchanger. It is not a block caused by large particles of ice but by the slow narrowing of the FLOW path capillary wall as the water vapour freezes out.

There are two possible sources for the water vapour:

1. Ice in the nitrogen supply - small particles of ice are sucked up the leg and flexible transfer line into the Coldhead. These particles pass through the Evaporator Heater and along the SUCT path of the heat exchanger. The ice then passes out of the Coldhead along the tubing marked SUCT, through the Controller, through the pump, back through the Controller and back into the Coldhead along the tubing marked FLOW or DEL. During its course along the nylon tubing, the ice melts to water vapour which, on entry into the FLOW path of the heat exchanger, refreezes causing narrowing of the capillary and an impending ice block. ICE PARTICLES DO NOT CAUSE THE BLOCK, WATER VAPOUR THAT FREEZES CAUSES THE BLOCK.

Note:

There is no easy way of completely removing particles of ice from your nitrogen supply. This means you will get this warning eventually, so do not panic!!

2. An inward leak - Atmospheric moisture is sucked into the gas stream on the SUCT path of the gas flow circuit at some point. The likely cause of this is a nylon tube NOT pushed its full 15-16mm into the quick-fit connector. If all the tubing has been resealed properly, it is possible the diaphragm in the Diaphragm Pump has split.

Solution

First, to remove the ice block, let your system warm up over night. The EvapT value on the Controller must reach room temperature as this indicates that the ice block has melted. When the system is restarted, the water vapour will blow, unnoticed, out of the end of the nozzle. If the Cryostream Cooler is required for use and it can not be left over night, disconnect the dry air supply for the Cryostream Cooler at the top of the nozzle and reconnect it to the FLOW connector on the top of the Coldhead. IMPORTANT: Reduce the flow on the dry air supply to 5 litres/minute to avoid any damage to the Gas Sensor in the nozzle. The dry air should be left running for a few hours until the EvapT value on the Controller reaches room temperature, this will blow out all the water vapour. Once this process has finished, reconnect all the tubing.

Ice in your nitrogen supply - empty the Dewar vessel and let it warm up to room temperature. Mop up any moisture in the bottom. Check on the purity of your liquid nitrogen by shining a flashlight into the Dewar. The liquid should look clean like water but do not worry if you see a few particles in the bottom, as this is fairly normal. If your liquid nitrogen is milky, you have a chronic contamination of ice, the Cryostream Cooler can not handle this so talk to your liquid nitrogen supplier. Try to avoid pushing the rigid leg of the Cryostream Cooler into the bottom of the Dewar, this prevents particles in the bottom of the Dewar being sucked up the leg. Dewars that are continually topped up should be emptied and cleaned out at least every three months, more often if possible.

An inward leak - Check to make sure all the nylon tubing is pushed 15-16mm into each quick-fit connector. It is worth marking each tube with a marker pen to be

sure that each tube is seated correctly. Perform the Nitrogen Circuit Gas Leak Test and inform Oxford Cryosystems or your local agent of your findings. Do not rush into changing a diaphragm as opening up the Diaphragm Pump can often cause a leak. The diaphragm in the grey Diaphragm Pump will last for approximately one year of continuous running. Speak to Oxford Cryosystems first.

Once the ice contamination problem has been rectified, fit an Oxford Cryosystems Line Drier Unit. If there is already one in circuit, it will now be contaminated and will require reactivation (see instructions). DO NOT fit a new one or a reactivated one until you have rectified the ice contamination. You will create unnecessary work and confusion for yourself.

Associated Symptoms

Controller Status reads 'Ice Block warning will trip at 2 l/min'

Cryostream Cooler Shutdown due to large temperature error

Cause

If the Cryostream Cooler has shut down after a period of time during which the gas temperature has risen steadily and the Heat% has read zero, there is a good chance the vacuum is deteriorating.

When the Cryostream Cooler experiences recondensation of nitrogen in its heat exchanger, the liquid will spit down the nozzle and hit the Gas Heater and Gas Sensor. This causes the temperature to jump around as it reacts to keep the temperature stable, (this instability may cause the shutdown after a period of time.) This will also be associated with a fluctuation in the Heater power (Heat%). This unbalance in the heat exchangers can be caused by an outward gas leak or an Evaporator Heater set too low.

Solution

It is worth considering these solutions in order:

1. If you suspect an outward gas leak, check to make sure all the nylon tubing is pushed 15-16mm into each quick-fit connector then perform the Nitrogen Circuit Gas Leak Test and contact Oxford Cryosystems or your local agent with your findings.
2. Increase your Evaporator setting by a few tenths of a degree at a time until the spitting has stopped. (600 Series Users: If you are running at around 90K your Heat% value should be typically 5-7%).
3. Repump your vacuum insulation in accordance with the instructions in the manual.

Associated Symptoms

Condensation and/or ice covering the outside of the blue Coldhead or the flexible transfer line

Spitting of liquid nitrogen from the nozzle

Cryostream Cooler Shutdown due to large temperature error with unusually high or low GasT

Cryostream Cooler Shutdown due to large temperature error when refilling the Dewar

Cryostream Cooler maintains an error of a few degrees that disappears when the Dewar is topped up

Cryostream Cooler Shutdown due to large temperature error with unusually high or low GasT

Cause

If the Cryostream Cooler has shutdown due to a large gas temperature error and either the error or gas temperatures are nonsense values, (eg 30K or 600K,) the system is suffering from electrical noise. Possible sources of electrical noise are a Rotating Anode generator, noisy mains supply or static electricity.

Solution

Often moving a large (100-200 litre) storage Dewar across a lab on rubber wheels can cause enough static to build up when the transfer hose it stuck in the opening of the Dewar. Be sure to earth the nitrogen storage Dewar before placing the transfer hose into the Dewar used by the Cryostream Cooler.

If the problem persists, contact Oxford Cryosystems or your local agent.

Cryostream Cooler Shutdown due to large temperature error when refilling the Dewar

Cause

1. It is important to remember that the inside of the Dewar used by the Cryostream Cooler is at about 80K. The air in the transfer hose from the storage Dewar is at about 300K. Spraying the warm air / nitrogen mixture into the Dewar without venting it first, CAN evaporate large amounts of liquid in the Dewar. This will cause a shutdown due to the presence of no nitrogen.
2. The pressure in the storage Dewar should be no greater than 1-2 bar. Refilling the Cryostream Cooler Dewar with a storage Dewar or cylinder under very high pressure will produce warmer liquid nitrogen. This warm nitrogen will cause a large temperature error.
3. Refilling the Cryostream Cooler Dewar with the transfer hose in the liquid nitrogen can blow enough gas into the liquid to turn it into Cryogenic Soda Water. This effervescence will cause the Cryostream Cooler to shut down.

Solution

1. Vent the transfer hose until the exit gas is cold.
2. In the short term, vent the storage Dewar to reduce the pressure. In the long term, modify the relief valve so the liquid nitrogen is stored between 1-2 bar.
3. Make sure the liquid nitrogen transfer hose from the supplier Dewar is out of the liquid nitrogen in the Cryostream Cooler Dewar during the refilling.

Associated Symptoms

Cryostream Cooler Shutdown due to large temperature error

Cryostream Cooler fails to initialise due to Gas Heater >64 ohms or <30 ohms

Cause

The Cryostream Cooler Gas Heater is either open circuit (>64 ohms) or short circuit (<30 ohms). This can be caused by corrosion or contamination from particles or liquids in the lab or letting the Dewar frequently run dry.

Solution

Make sure the Cryostream Cooler nozzle is not angled at less than 20° from the horizontal. This will prevent condensable from attacking the Gas Heater when the system is switched off.

Make sure there is always, at least, 5 inches of liquid nitrogen in the bottom of the Dewar.

Contact your local agent or Oxford Cryosystems to arrange of the component to be repaired.

Cryostream Cooler fails to initialise due to Gas Sensor Error

Cause

The Cryostream Cooler Gas Sensor is a very delicate silicon diode positioned just inside the end of the nozzle. If an object such as a pen, mounting pin or goniometer arc is inserted into the nozzle, this can cause damage to the sensor. Very much like the Gas Heater, damage to the Gas Sensor can be caused by corrosion from particles or liquids in the lab.

Solution

Warn all users not to push anything up the nozzle. Take extra care when placing and removing Top hats / Caps from the goniometer. No maintenance should take place via the nozzle exit.

Make sure the Cryostream Cooler nozzle is not angled at less than 20° from the horizontal. This will prevent condensable material from attacking the Gas Heater when the system is switched off.

Contact your local agent or Oxford Cryosystems to arrange of the component to be repaired.

Cryostream Cooler fails to initialise due to Evap Heater or Evap Sensor error

Cause

As these components are secured tightly inside the blue body of the Coldhead, it is very rare for them to get damaged. The most likely cause of damage to these components is from an electrical surge.

Solution

Contact Oxford Cryosystems or your local agent immediately. Do not try to service this yourself as there are no user serviceable parts inside the Coldhead.

Diaphragm Pump is making a strange noise

Cause

Although sounds are often difficult to interpret it is worth noting a few things. The noises from the Diaphragm Pumps vary from pump to pump and voltage to voltage. If you are unhappy with the noise your pump is making, possible causes are:

1. a rattling or knocking can often indicate a broken con rod.
2. a grinding usually indicates a failed bearing.
3. a slapping noise can be produced by the diaphragm. IT IS NOT USUALLY A FAULT.

Solution

Contact your local agent or Oxford Cryosystems to get the replacement part or the pump serviced.

Nitrogen Circuit Gas Leak Test

Wait for the Cryostream Coldhead to reach room temperature. This will usually require leaving the system overnight. Once the inside of the Coldhead has warmed up, remove the leg from the liquid nitrogen and allow that to also warm up (15-20 minutes.) These precautions prevent atmospheric moisture from contaminating the inside of Cryostream.

Disconnect the nylon tubes from the FLOW and SUCT Quick-Fit Connectors on the top of the Cryostream Coldhead flange.

If a Line Drier Unit is fitted, remove it from the nitrogen gas flow circuit. (If the Line Drier Unit is not removed, it will be contaminated with atmospheric moisture. Leaving the Line Drier Unit in the circuit will smooth the flowmeter reading.)

Disconnect the two mains cables from the back of the Cryostream Controller. (500 Series Cryostream Cooler users should disconnect the mains cable from the back of the Cryostream Controller and the cable from the back of the Gas Flow Unit.) Run the Diaphragm Pump directly from the mains by connecting the two cables together.

The gas flowrate should read 5 litres / minute on your flowmeter. The top edge of the float should touch the bottom of the number '6' on the float.

To Check for an Inward Leak

While the Diaphragm Pump is running directly from the mains, place a finger over the tube taken from the SUCT connector on the Coldhead. If the flow does not fall slowly to zero, then the system has an INWARD leak.

Likely Causes of Inward Leaks

1. Check to make sure all the nylon tubes are firmly nested in all the Quick-Fit Connectors, (15-16mm).
2. A split in the Pump Diaphragm. Contact your local Cryostream agent or Oxford Cryosystems, about getting a new one.

To Check for an Outward Leak

While the Diaphragm Pump is running directly from the mains, place a finger over the tube taken from the FLOW Connector on the Cryostream Coldhead. If the flow does not fall to zero, then the system has an OUTWARD leak. If a Line Drier Unit is not fitted, the float may bobble around at the bottom of the flowmeter, this is expected.

Likely Causes of Outward Leaks

1. Check to make sure all the nylon tubes are firmly nested in all the Quick-Fit Connectors, (15-16mm).
2. Check for cracks in the flowmeter on the front of the Cryostream Controller, (or Gas Flow Unit on the 500 Series Cryostream Cooler.)

Flashlight Test

To be sure the flow rate of the outer dry air stream is correct, it is often better to set the flow by eye rather than by trying to guess what the flow should be by looking at the numbers.

Turn all the lights off in the x-ray room and shine a flashlight up towards the nozzle of the Cryostream Cooler in an attempt to highlight the plume created by the cold gas stream. As the gas stream leaves the nozzle it is really made up of two parts; the first 'invisible' 10 or 12 mm and the remaining plume of ice. The object of the exercise is to maximise the length of the 'invisible' section. This should only be done over the first 15 litres / minute of air from the dry air source. One should not be fooled into thinking that at 25 litres / minute there is no plume, and therefore, no ice because the ice will build rapidly around the end of the nozzle and blow the sample from its support.

Technical Support

To allow Oxford Cryosystems to offer fast and accurate technical support please quote your Cryostream Cooler Serial Number with all technical issues. This is a three digit number and can be found etched on the top of the blue Coldhead section of the Cryostream Cooler. This number is also on the back panel of the controller. Please do not confuse it with the six-digit controller number. It is worth keeping a record of this number in a convenient place:

Cryostream Cooler Serial Number

This Cryostream Cooler Serial Number is

To make contact with Oxford Cryosystems you can telephone, fax, or email us at:

Oxford Cryosystems
3 Blenheim Office Park
Lower Road
Long Hanborough
Oxford OX8 8LN
UK
Tel: +44 1993 883488 Fax: +44 1993 883988
Email CryostreamSupport@OxfordCryosystems.co.uk