

SENSOTEC



Model SC2001

SC Instrumentation

*Signal Conditioning,
Self-Calibrating
Digital Indicators*



Models SC1000 & SC2000

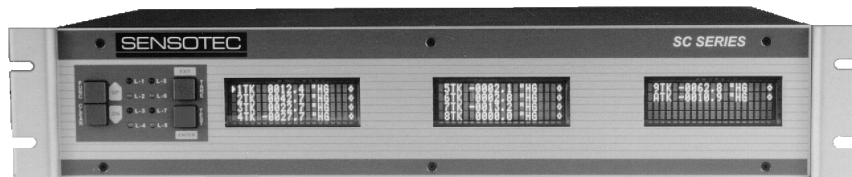

Model SC3004

*Pressure
Transducers*

Load Cells

Accelerometers

*Displacement
Transducers*

Instrumentation

Sensotec, Inc.
2080 Arlingate Lane
Columbus, Ohio 43228 USA
Copyright © 2000 by Sensotec, Inc. all rights reserved
Telephone: (614)850-5000
FAX: (614)850-1111
Toll Free: 1-800-848-6564
E-mail: service@sensotec.com
WWW: <http://www.sensotec.com>

SC Series Instruction Manual
Models SC1000, SC2000, SC2001 and SC3004

Sensotec Document Number: 008-0608-00
Rev. B: January, 2002

IMPORTANT

It is recommended that you read “Getting Started Quickly” on page 15 thoroughly before applying power to this unit.



CAUTION: The operator of this instrument is advised that if the equipment is not used in a manner not specified in this manual, the protection provided by the equipment may be impaired.



CAUTION: Only qualified, service-trained personnel who are aware of the hazards involved should remove the cover from the instrument or connect external wiring to the instrument.

Sensotec and the Sensotec logo are registered trademarks of Sensotec, Inc.

Printed in U.S.A.

Sensotec continually improves its products, and thus the information herein is subject to change without notice.

Contents	3
Chapter 1	
Introduction	9
1.1 About This Manual	9
1.1.1 Scope	9
1.1.2 Conventions	9
1.1.3 Organization	9
1.2 Related Documents	11
1.3 What is the SC Series?	12
1.3.1 Features	12
1.3.2 Chassis Models	12
1.3.3 Channel Types	12
1.4 What is <i>Signature Calibration</i> ?	14
1.4.1 Overview	14
1.4.2 Benefits	14
1.4.3 Information Stored	14
Chapter 2	
Getting Started Quickly	15
2.1 Locate Required Parts and Information	15
2.2 Connect the Transducer to the Correct Channel of the Instrument	15
2.3 Turn on the Instrument	16
2.4 Use the SETUP Menus to Enter Transducer Information	17
2.5 Calibrate the Transducers to Their Channels	17
2.6 The SC Series Instrument is Ready for Use	17
Chapter 3	
Operating Modes	19
3.1 Operating Modes	19
3.2 INITIALIZE Mode	19
3.3 RUN Mode	20
3.3.1 Display	20
3.3.2 [VALUE] button	20
3.3.3 [CLEAR] Button	20
3.3.4 [CHANNEL] button	21
3.3.5 [TARE] button	21
3.3.6 Indicator Lights	21
3.4 ERROR mode	22
3.5 SETUP Menu mode	23
3.5.1 Available Menus	23
3.5.2 Entering and Exiting the SETUP Menu mode	23
3.5.3 Moving Through SETUP Menus and Menu Items	23
3.5.4 Exiting the SETUP Menu mode	23

Chapter 4	
Chassis Models	25
4.1 Introduction	25
4.2 Specifications	26
4.3 Models SC1000 and SC2000	27
4.3.1 Differences	27
4.3.2 External Arrangement	27
4.3.3 Rear Panel	27
4.3.4 Panel Mounting	27
4.3.5 Rack Mounting	28
4.3.6 Bench Mounting	28
4.3.7 Case Removal	28
4.3.8 Internal Arrangement	29
4.3.9 Cleaning	30
4.3.10 Vehicle Power Option	30
4.3.11 Fuse Replacement	30
4.4 Model SC2001	31
4.4.1 Differences	31
4.4.2 External Arrangement	31
4.4.3 Front Panel	31
4.4.4 Case Removal	31
4.4.5 Internal Arrangement	32
4.4.6 Cleaning	32
4.4.7 Vehicle Power Option	32
4.4.8 Fuse Replacement	32
4.5 Model SC3004	33
4.5.1 External Arrangement	33
4.5.2 Rear Panel	33
4.5.3 Panel Mounting	33
4.5.4 Bench Mounting	34
4.5.5 Case Removal	34
4.5.6 Rear Panel	34
4.5.7 Internal Arrangement	34
4.5.8 Cleaning	34
4.5.9 Fuse Replacement	34
 Chapter 5	
System Connector	35
5.1 Introduction	35
5.2 System Connector Pinout	36
5.3 Function Input Pins	37
5.3.1 Overview	37
5.3.2 Example	37
5.4 Limit Output Pins	38
5.4.1 Overview	38
5.4.2 Example	38
 Chapter 6	
System Menu	41
6.1 Overview	41
6.2 Menu Items	41
6.2.1 SOFTWARE REVISION Menu Item	41
6.2.2 CONFIGURATION Sub-Menu	41
6.2.3 DIAGNOSTICS Sub-Menu	41

6.2.4 INSTALL CHANNEL Menu Item	42
6.2.5 DELETE CHANNEL Menu Item	44
6.2.6 DEFAULT CHANNEL Menu Item	44
Chapter 7	
Serial Communications	47
7.1 Overview	47
7.2 Rear Panel Connector	47
7.3 Communications Protocol	48
7.3.1 RS-232 vs. RS-485	48
7.3.2 Parameters	48
7.4 Serial Com. Menu	49
7.4.1 Overview	49
7.4.2 INTERFACE Menu Item	49
7.4.3 ADDRESS Menu Item	49
7.4.4 BAUD RATE Menu Item	49
7.4.5 AUTO LINE-FEED Menu Item	49
7.4.6 TRANSMIT TEST Menu Item	49
7.4.7 LEAVE MENU Menu Item	49
Chapter 8	
Display Menu	51
8.1 Overview	51
8.2 Menu Items for Models SC1000, SC2000, SC2001	51
8.2.1 UPPER CHANNEL Menu Item	51
8.2.2 LOWER CHANNEL Menu Item	51
8.2.3 LOWER MODE Menu Item	51
8.2.4 DISPLAY DISABLE Menu Item	51
8.3 Menu Items for Model SC3004	52
8.3.1 POWER-ON CHANNEL Menu Item	52
Chapter 9	
Limits	53
9.1 Understanding Limits, Set Points and Return Points	53
9.2 Limit Operation	54
9.2.1 Actions When Activated	54
9.2.2 Scan Time	54
9.3 Limit Menus	55
9.3.1 Overview	55
9.3.2 LIMIT. ENABLE Menu Item	55
9.3.3 LIMIT. SETPOINT Menu Item	55
9.3.4 LIMIT. RETURN PNT Menu Item	55
9.3.5 LIMIT. ENERGIZE Menu Item	55
9.3.6 LIMIT. LATCHING Menu Item	57
9.3.7 LIMIT. CHANNEL Menu Item	57
9.3.8 LIMIT. SOURCE Menu Item	57
9.3.9 LEAVE MENU Menu Item	57
Chapter 10	
Strain-Gage Input Channel	59
10.1 Features	59
10.2 Wiring	60
10.3 Calibration Procedure	61

10.4 Specifications	62
10.5 Channel Menu	63
10.5.1 OPERATION Sub-Menu	63
10.5.2 DISPLAY SETUP Sub-Menu	65
10.5.3 AUX _n FUNCTION Menu Items	66
10.5.4 CALIBRATION TYPE Menu Item	67
10.5.5 CALIBRATION DATA Sub-Menu	69
10.5.6 CALIBRATE Menu Item	71
10.5.7 DAC SETUP Sub-Menu	73
10.5.8 SIGNATURE MODULE Sub-Menu	74
10.5.9 DIAGNOSTICS Sub-Menu	75
10.6 Analog Output Configuration	76
10.6.1 Identifying the Output Type	76
10.6.2 Channel Menu Items	76
10.6.3 Output Selection	76
10.7 Troubleshooting	77
10.7.1 Error Messages	77
10.7.2 Common Problems and Solutions	77

Chapter 11

AC/AC-LVDT Input Channel	79
11.1 Features	79
11.2 Wiring	80
11.3 Calibration Procedure	81
11.4 Specifications	82
11.5 Channel Menu	83
11.5.1 OPERATION Sub-Menu	83
11.5.2 DISPLAY SETUP Sub-Menu	85
11.5.3 AUX _n FUNCTION Menu Items	85
11.5.4 CALIBRATION TYPE Menu Item	87
11.5.5 CALIBRATION DATA Sub-Menu	88
11.5.6 CALIBRATE Menu Item	89
11.5.7 DAC SETUP Sub-Menu	91
11.5.8 DIAGNOSTICS Sub-Menu	92
11.6 Electrical Null and Transducer Mounting	93
11.6.1 Overview	93
11.6.2 Procedure	93
11.7 Analog Output Configuration	94
11.7.1 Identifying the Output Type	94
11.7.2 Channel Menu Items	94
11.7.3 Output Selection	94
11.8 Troubleshooting	95
11.8.1 Error Messages	95
11.8.2 Common Problems and Solutions	95

Chapter 12

High-Level Input Channel	97
12.1 Features	97
12.2 Wiring	98
12.2.1 Channel Connector	98
12.2.2 Bi-polar Voltage Amplifiers	99
12.2.3 Vehicle Voltage Amplifiers	100
12.2.4 “3-wire Current” Amplifiers	101

12.2.5 “2-wire Current” Amplifiers with Buffered Shunt Cal	102
12.2.6 “2-wire Current” Amplifiers with Single-wire Shunt Cal	103
12.2.7 Low Voltage DC-DC LVDTs	104
12.3 Excitation and Signal Jumpers	105
12.3.1 Overview	105
12.3.2 Setting Jumpers	105
12.4 Calibration Procedure	106
12.5 Specifications	107
12.6 Channel Menu	108
12.6.1 OPERATION Sub-Menu	108
12.6.2 DISPLAY SETUP Sub-Menu	110
12.6.3 AUX _n FUNCTION Menu Items	111
12.6.4 CALIBRATION TYPE Menu Item	112
12.6.5 CALIBRATION DATA Sub-Menu	114
12.6.6 CALIBRATE Menu Item	116
12.6.7 DAC SETUP Sub-Menu	118
12.6.8 DIAGNOSTICS Sub-Menu	119
12.7 Analog Output Configuration	120
12.7.1 Identifying the Output Type	120
12.7.2 Channel Menu Items	120
12.7.3 Output Selection	120
12.8 Troubleshooting	121
12.8.1 Error Messages	121
12.8.2 Common Problems and Solutions	121
Chapter 13	
Relay Output Channel	123
13.1 Features	123
13.1.1 First Channel Installed	123
13.1.2 Second Channel Installed	123
13.1.3 Third Channel Installed	123
13.1.4 Fourth Channel Installed	123
13.2 Wiring	124
13.3 Setup Procedure	125
13.4 Specifications	126
13.5 Channel Menu	127
13.5.1 DIAGNOSTICS Sub-Menu	127
Chapter 14	
DAC Output Channel	129
14.1 Features	129
14.2 Wiring	130
14.3 Setup Procedure	131
14.4 Specifications	132
14.5 Channel Menu	133
14.5.1 DAC SETUP Sub-Menu	133
14.5.2 DIAGNOSTICS Sub-Menu	134
14.6 Analog Output Configuration	135
14.6.1 Identifying the Output Type	135
14.6.2 Channel Menu Items	135
14.6.3 Output Selection	135
14.7 Troubleshooting	136
14.7.1 Error Messages	136

14.7.2 Common Problems and Solutions	136
--	-----

Chapter 15

Split Display Virtual Channel	139
15.1 Features	139
15.2 Wiring	139
15.3 Setup Procedure	139
15.4 Channel Menu	140

Chapter 16

Mathematics Virtual Channel	141
16.1 Features	141
16.2 Wiring	142
16.3 Setup Procedure	143
16.4 Channel Menu	144
16.4.1 SENSOCODE P/N Menu Item	144
16.4.2 USER VALUES Sub-Menu	144
16.4.3 VIEW SENSOCODE Menu Item	144
16.4.4 VIEW COMMANDS Sub-Menu	144
16.4.5 DISPLAY SETUP Sub-Menu	145
16.4.6 POWER-ON SOURCE Menu Item	146
16.5 Troubleshooting	147

Chapter 17

Error Messages	149
17.1 Overview	149
17.2 Error Message List	150

Chapter 18

Setup Menu Reference	155
18.1 Navigation instructions	155

Index	167
--------------------	------------

Warranty/Repair Policy	171
-------------------------------------	------------

1.1 About This Manual

1.1.1 Scope This manual will explain the setup, features and operation of Sensotec's 3rd generation SC Series instruments. This series includes the models SC1000, SC2000, SC2001, and SC3004.

Further information about customer specific programming and setup will be explained on the Customer Information Sheet that is provided with every instrument.

1.1.2 Conventions This manual uses the following conventions to present information:

[TEXT IN BRACKETS]	The label of a front panel button.
DISPLAY	Text that appears on the display, such as error messages or menu items.
->	Indicates that what follows is an item from a sub-menu, such as SYSTEM MENU -> DIAGNOSTICS .

1.1.3 Organization **Chapter 1, "Introduction"**, offers general information about the SC Series and this instruction manual.

Chapter 2, "Getting Started Quickly", provides an overview of how to get started quickly if your instrument and transducers were ordered at the same time from Sensotec, or if *Signature Calibration* is used.

Chapter 3, "Operating Modes", discusses the significant features of the SC Series and operation procedures when the instrument is in the INITIALIZE, RUN, ERROR or SETUP modes.

Chapter 4, "Chassis Models", explains the differences between the SC1000, SC2000, SC2001 and SC3004 chassis. Information relating to the hardware chassis such as panel and rack mounting is given.

Chapter 5, "System Connector", contains information about wiring to the 25-pin System connector to access the Limit Outputs, Function Inputs and serial communications.

Chapter 6, "System Menu", discusses the System menu which allows you to examine and change settings that affect the operation of the chassis.

Chapter 7, "Serial Communications", briefly describes RS-232 and RS-485 communications. It also shows how to use the **Serial Com.** Menu to examine the settings and test the RS-232 or RS-485 communications.

Chapter 8, "Display Menu", describes the Display Menu which allows you to change what is displayed on the lower line of the SC2000 and SC2001 instruments.

Chapter 9, “Limits”, discusses how the limits operate and describes how to alter their settings via the Limit Menus.

Chapter 10, “Strain-Gage Input Channel”, explains how to wire, configure, operate and calibrate Strain-Gage Input Channels with your transducers.

Chapter 11, “AC/AC-LVDT Input Channel”, explains how to wire, configure, operate and calibrate AC/AC-LVDT Input Channels with your transducers.

Chapter 12, “High-Level Input Channel”, explains how to wire, configure, operate and calibrate High-Level Input Channels with your amplified transducers, in-line amplifiers, or DC-DC LVDTs.

Chapter 13, “Relay Output Channel”, describes how a Relay Output channel can enable additional limits in the instrument.

Chapter 14, “DAC Output Channel”, explains the configuration and operation of additional digital-to-analog voltage or current outputs.

Chapter 15, “Split Display Virtual Channel”, shows how you can display two values from any of the channels in the instrument at the same time.

Chapter 16, “Mathematics Virtual Channel”, describes the flexibility of customer-specific SensoCode programming.

Chapter 17, “Error Messages”, lists error messages that the instrument may display, describes their causes and, where possible, suggests solutions.

Chapter 18, “Setup Menu Reference”, is a list of all SETUP menus and a cross-reference to related information in this instruction manual.

1.2 Related Documents

Customer Information Sheet	<p>Every instrument is shipped with a Customer Information Sheet which documents important information specific to each instrument, such as:</p> <ul style="list-style-type: none">• Sensotec part number,• date of manufacture,• list of all installed channels and their setup information,• customer specific SensoCode programming of Mathematics Virtual channels and operation notes.
Communications Guide	<p>The “SC Series Communications Guide”, Sensotec p/n 008-0610-00, describes in detail how to communicate with an SC Series instrument using RS-232 and RS-485. Wiring diagrams, sample programs, and descriptions of each command are included.</p> <p>A printed copy of this document is available for order, or you may download it from Sensotec’s web site, www.sensotec.com.</p>

1.3 What is the SC Series?

The Sensotec SC Series of Signal Conditioners/Indicators are versatile, multi-channel devices designed to operate with many different types of sensors. Several different chassis types, Input channels, and Output channels are available to allow the configuration of an SC instrument to meet a variety of measurement and control needs. The operation of an SC instrument is based on digital technology to provide improved accuracy, superior ease of setup, and a wealth of features.

1.3.1 Features

The main features of the SC Series are:

- Four alarm limits (optional sixteen), with versatile setup (not available on Model SC1000)
- Automatic setup, calibration, and scaling of strain-gage sensors through the use of *Signature Calibration*TM
- Field selectable, digital, low-pass filtering (“damping”) on each Input channel
- Up to $\pm 50,000$ part resolution
- Field selectable five-, six - or seven-digit (9,999,999 maximum) display
- RS-232 communications standard (RS-485 optional)
- Local or remote setup using the RS-232 or RS-485 port
- Push-button on/off tare feature
- No knobs or adjustments

1.3.2 Chassis Models

Several models (i.e chassis types) are available:

- **SC1000**: 1 to 4 physical channels, 3/8 DIN case, no limits or peak detector
- **SC2000**: 1 to 4 physical channels, 3/8 DIN case
- **SC2001**: 1 to 4 physical channels, portable case
- **SC3004**: 1 to 14 physical channels, 19” rack mount case, 1 to 3 quad-line displays

1.3.3 Channel Types

Channels can be one of three types: Input, Output, or Virtual

Input Channels

Input channels are hardware circuit boards with a unique channel number. Currently, they are available for the following types of sensors:

- Strain-gage sensors, such as unamplified pressure transducers and load cells
- Sensors with voltage outputs, such as Sensotec transducers with the Option 2a, 2b, 2c or 2t internal amplifier
- Sensors with current outputs, such as Sensotec transducers with the Option 2j, 2k or 2n internal amplifier
- AC-AC LVDT's (Linear Variable Displacement Transducers)
- DC-DC LVDTs

Output Channels

Output channels are hardware circuit boards with a unique channel number. They include:

- Relay Output channels, which can add additional limits to the standard four (N/A on Model SC1000).
- DAC Output channels, which provide additional voltage or current outputs.

Virtual Channels

Virtual channels are software based devices that occupy a channel number, but not a physical slot, in an instrument.

- Split Display Virtual channels allow the displaying of any two channel's track, peak or valley values at the same time.
- Mathematics Virtual channels run small programs written in an interpretive language called SensoCode. This provides great flexibility which allows the SC Series to do many jobs which otherwise requires a personal computer or PLC.

1.4 What is *Signature Calibration*?

1.4.1 Overview

A small integrated circuit is located either inside the transducer, in an in-line package between the instrument and the transducer, or in the connector of a cable. All data necessary to set up the transducer with the instrument are stored (even linearity data), and setup is automatic when the a new transducer is connected to the instrument.

The Strain-Gage Input channel of the Sensotec SC Series is designed to operate with *Signature Calibration*. It will automatically set itself up with transducers which contain the memory device, but can also be set up using a front-panel interactive procedure. The *Signature Calibration* module can also be programmed from the instrument's front panel.

Signature Calibration is only available with unamplified strain-gage transducers.

1.4.2 Benefits

The benefits are:

- The transducer's Calibration Record is always located where it is needed most... with the transducer.
- The instrument is always set up correctly with the transducer.
- Interchanging of transducers and instruments is a quick process.
- A User Calibration Data area that can be altered by customers to fit their requirements.
- A Factory Calibration Sheet Data area, unalterable by the customer, can be copied back into the User Calibration Data.

1.4.3 Information Stored

The following information is stored inside transducers equipped with *Signature Calibration* :

- Full-scale mV/V: The full-scale millivolt-per-volt (mV/V) rating of the transducer when its full load is applied; also called "calibration factor".
- Shunt-Cal mV/V: The millivolt-per-volt output of the transducer when the shunt calibration resistor is placed across its -SIGNAL and -EXCITATION leads.
- Shunt Resistance: The resistance value, in Ohms, that was used to obtain the shunt-cal mV/V value above.
- Full-Scale Value: The full scale value of the transducer, in engineering units.
- Engineering Units: The engineering units that the transducer is calibrated in (i.e. pounds, grams, pascals, inches of water, etc.)
- Serial Number: The serial number of the transducer.
- Excitation Voltage: The magnitude and type of signal used to excite the transducer.
- Linearization Points (optional): These can be used by an instrument using Shunt Calibration or Millivolt-per-Volt Calibration to correct any non-linearity in the transducer and thus improve the accuracy of the system. An additional "multiple-point calibration" can be purchased with the transducer that allows linearity correction information to be placed into its *Signature Calibration* module.

Chapter 2

Getting Started Quickly

2.1 Locate Required Parts and Information

The following items are required to set up an SC Series instrument with your transducer:

- SC Series instrument
- Transducers that are to be connected to the instrument
- For each transducer to be connected to the instrument, a connecting cable. This cable will have a 12-pin, green, plastic connector on one end and the transducer's mating connector on the other end. Usually, this cable is ordered along with the instrument and transducer. If the connecting cable was not ordered from Sensotec, you may need to make this cable.
- The transducer's Calibration Record or Certificate of Calibration.
- The Customer Information Sheet that shipped with your instrument. This sheet describes which cards are installed in each channel.
- Power cord for the instrument.

2.2 Connect the Transducer to the Correct Channel of the Instrument

For each transducer, attach its connecting cable to the transducer, and then to the correct 12-pin channel-connector on the instrument.

The Customer Information Sheet indicates which serial numbered transducer is to be connected to each channel of the instrument.

If the instrument and transducer(s) were not purchased with a connecting cable from Sensotec, you may need to make this cable. For the transducer's pin connections, see that transducer's calibration record. For the pin connections for that channel of the instrument, see the appropriate chapter in this manual. For example, if you wish to wire to a Strain-Gage Input Channel see the chapter "Strain-Gage Input Channel" on page 59.

2.3 Turn on the Instrument

Connect the power cord between the instrument power source and the instrument, and turn the On/Off switch on the back of the instrument to the On position.

The instrument enters its INITIALIZE mode that lasts a few seconds per channel. As each channel in the instrument is initialized, the transducer's serial number may be seen on the display if the transducer has a *Signature Calibration Module* in it.

If the channel's display flashes "APPLY 00000." (or some other load value), the instrument has detected a transducer other than the one which was last calibrated with that channel. The instrument is prompting you to apply the requested load to the transducer so that a "mV/V Calibration" or a "Shunt Calibration" can take place.

After making certain that the correct transducer is connected this channel, press the [ENTER] button after you have applied the requested load to perform the calibration.

If the instrument displays error code 57 or 68, it has detected a transducer other than the one which was last calibrated with that channel. Furthermore, the channel cannot perform an automatic calibration because its calibration type has been set to "Known Load Calibration".

Either re-connect the correct transducer to the channel, or see "CALIBRATION TYPE Menu Item" on page 67 to select another calibration type.

When the instrument enters its normal operating mode (RUN mode), you will see the following format on the front panel display:

1▲ 00000. PSIG ◇

where:

- **Channel number:** "1" is the channel number.
- **Value type:** The next character indicates the nature of the following value. A blank character indicates the tracking value. The instrument is "tracking" the signal, continuously updating the display in response to the signal from the transducer. A "▲" character indicates the peak value (highest value seen since the [CLEAR] button was last pressed). A "▼" character indicates the valley value (lowest value seen since the [CLEAR] button was last pressed).
- **Data value:** "00000." displays the value from the transducer in engineering units.
- **Units label:** "PSIG" indicates the engineering units being used (up to 4 characters).
- **Tare indicator:** A "◇" symbol indicates tare is off; a "◆" symbol indicates tare is on.

2.4 Use the SETUP Menus to Enter Transducer Information

You can skip this step if:

- You are using a transducer equipped with *Signature Calibration*, or
- The transducer and instrument were purchased together and set up by Sensotec.

Otherwise, you must enter information about your transducer into the SETUP menu of the channel to which it is connected. See the appropriate chapter of this manual for that card type.

2.5 Calibrate the Transducers to Their Channels

You can skip this step if:

- You are using a transducer equipped with *Signature Calibration*, or
- The transducer and instrument were purchased together and set up by Sensotec.

Otherwise, you must choose a calibration method (e.g. Shunt Calibration, mV/V Calibration, or Known Load Calibration) appropriate for your application and use the SETUP menu for that channel to calibrate the channel to the transducer. See the appropriate chapter of this manual for that card type.

2.6 The SC Series Instrument is Ready for Use

See "RUN Mode" on page 20 for information on how to operate the instrument while it is in the RUN mode.

Apply some test stimulus on the transducer to observe changes in the display.

Chapter 3

Operating Modes

3.1 Operating Modes

The SC Series instruments have four modes of operation:

- INITIALIZE, to test the instrument upon power up
- RUN, normal operation
- ERROR, which indicates that an abnormal situation has occurred that stopped the operation of the instrument
- SETUP, a menu which allows setup and calibration of the chassis and its channels.

Each of these will be described in this chapter.

3.2 INITIALIZE Mode

When the instrument is powered up or otherwise reset, it enters the INITIALIZE mode. As the instrument enters this mode, all segments of the display and all front panel indicator lights (if available) illuminate momentarily. Next, each channel in the instrument is checked for proper operation.

If a problem is detected, the instrument may enter the ERROR mode.

Depending on the type of channel, other actions may occur. For example, a Strain-Gage channel will calibrate its analog-to-digital converter and attempt to read the transducer's *Signature Calibration* information. If the transducer is equipped with *Signature Calibration*, the transducer's serial number is displayed momentarily.

3.3 RUN Mode

After the INITIALIZE mode finishes, the instrument enters the RUN mode, its normal mode of operation.

3.3.1 Display

Model SC3004 and
upper line of SC1000,
SC2000, SC2001

The display will show a channel number on the far left, followed by the channel's operation messages.

For example, a Strain Gage amplifier channel will use the format below:

1▲ 00000. PSIG ◇

where:

- **Channel number:** "1" is the channel number.
- **Value type:** The next character indicates the nature of the following value. A blank character indicates the display is being continuously updated by "tracking" the input signal to the channel. A "▲" character indicates the peak value (highest value seen since the [CLEAR] button was last pressed). A "▼" character indicates the valley value (lowest value seen since the [CLEAR] button was last pressed).
- **Data value:** "00000." displays the value from the transducer in engineering units.
- **Units label:** "PSIG" indicates the engineering units being used (up to 4 characters).
- **Tare indicator:** A "◇" symbol indicates tare is off; a "◆" symbol indicates tare is on.

Lower Line of SC1000,
SC2000, SC2001

The contents of the display's lower line is selected with the "DISPLAY MENU -> LOWER MODE" menu item as either displaying a channel or indicating the status of Limits. See "Indicator Lights" on page 21.

3.3.2 [VALUE] button

The [VALUE] button is not used by SC1000 instruments in the RUN mode.

After the channel number, the next characters indicate which data value for the displayed channel is shown. There are three (possibly four) data values available from each channel:

- (blank), tracking data value
- "▲", peak data value, (highest value since the peak/valley detector was cleared)
- "▼", valley data value, (lowest value since the peak/valley detector was cleared)
- "□", percentage of the Analog-to-Digital converter's full-scale digitizing capability. This data value is only available when the channel's "DIAGNOSTICS->DISPLAY ADC" menu item is set to "ON".

Pressing and releasing the [VALUE] button cycles through the available sources for data values for the displayed channel.

3.3.3 [CLEAR] Button

Pressing and releasing the [CLEAR] button will reset the peak and valley values of the channel being monitored by the display to the track value. Additionally, any limits in the instrument that are "latched" will be reset.

The [CLEAR] button is not used by SC1000 instruments in RUN mode.

To clear the peak and valley values of all channels simultaneously, use the System connector's Function Input #2 pin. See "System Connector" on page 35 for details.

To clear the peak and valley values of a single channel regardless of which channel is being monitored by the display, use the channel's AUX1 or AUX2 control pins on its connector. See the particular chapter regarding that channel for details.

3.3.4 [CHANNEL] button

If the configuration of the instrument contains more than one channel, the left most characters of the display indicates which channel the display is monitoring. Pressing and releasing the [CHANNEL] button will cause the next channel to be displayed.

On instruments with a dual-line display, the [CHANNEL] button cannot be used to change which channel the lower line is monitoring. That is selected with the "DISPLAY MENU -> LOWER CHANNEL" menu item.

If the [CHANNEL] button is held down for more than 3 seconds, the present channel's shunt calibration value (if the channel has shunt calibration available) will be displayed.

3.3.5 [TARE] button

To reset the channel's display to zero, press the [TARE] button while in RUN mode. To restore the tare value, press the [TARE] button again. The "Tare" indicator will illuminate when tare is on.

To tare all channels simultaneously, use the System connector's Function 1 Input pin. See "System Connector" on page 35.

To tare a single channel regardless of which channel is being monitored by the display, use the channel's AUX1 or AUX2 control pins on its connector. See the particular chapter regarding that channel for details.

3.3.6 Indicator Lights

Models SC1000, SC2000, SC2001

A "◇" symbol on the right side of a channel's display indicates tare is off for that channel; a "◆" symbol indicates tare is on.

If the lower line of the display is configured with the "DISPLAY MENU -> LOWER MODE" menu item as "LIMIT 01-04", then the lower line will monitor the status of Limits 1, 2, 3 and 4. A "◇" symbol indicates a limit is deactivated; a "◆" symbol indicates a limit is activated. For example:

L1◇ L2◇ L3◆ L4◆

indicates that Limit 1 and Limit 2 are deactivated and Limit 3 and Limit 4 are activated. Since the SC1000 is not equipped with limits, the lower line of the display will be blank. See "LOWER MODE Menu Item" on page 51.

These indicators may be overridden by the operation of a Mathematics channel in special applications.

Model SC3004

Front panel lights "L-1", "L-2", "L-3", and "L-4", monitor the status of Limits 1, 2, 3, and 4. Model SC3004 instruments also include front panel lights labeled "L-5", "L-6", "L-7" and "L-8" which monitor the status of optional Limits 5, 6, 7, and 8.

The function of the front panel lights may be overridden by the operation of a Mathematics channel in special applications.

3.4 ERROR mode

The instrument enters the ERROR mode when a critical error occurs that prevents the instrument from operating. The display alternates between displaying a two-digit code in the form "ERROR xx ON CH.yy" and a short description of the error. The first two digits "xx" hold the error code. The last two digits, "yy" is channel number that caused the error. For example, "ERROR 60 ON CH.01" indicates that error number 60 occurred on channel 1.

While the instrument is in the ERROR mode, no other operations are taking place. See "Error Message List" on page 150 for a list of error codes and their probable causes.

3.5 SETUP Menu mode

The SETUP Menu mode is used to display or change the settings that control the operation of the instrument.

3.5.1 Available Menus

Each major function of the instrument has its own SETUP Menu. See “Setup Menu Reference” on page 155.

3.5.2 Entering and Exiting the SETUP Menu mode

To enter the SETUP Menu mode, press and hold the [UP] and [DOWN] buttons at the same time until you see “SETUP” on the display. When you release the buttons, you will see the first SETUP Menu item.

To leave SETUP mode and return to the RUN mode, press [EXIT].

3.5.3 Moving Through SETUP Menus and Menu Items

The following table shows how to move through menus and menu items, and how to display or change the setting of a particular item.

Table 3-1: Navigating the Menus

Button	Action
[UP] or [DOWN]	Scroll through available menus, sub-menus or menu items.
[ENTER]	Select a menu, sub-menu or menu item
[EXIT]	If changing a setting...abandons changes to a menu item otherwise...leaves the SETUP mode.

To change the setting of a menu item...

Press [ENTER] to display the current setting, which is preceded by the ‘*’ character. Press [UP] or [DOWN] until you see the setting you want. To abandon changes, press [EXIT]. To accept the new setting and move to the next item, press [ENTER].

3.5.4 Exiting the SETUP Menu mode

To leave SETUP mode and return to the RUN mode, press [EXIT] at any time.

Chapter 4

Chassis Models

4.1 Introduction

The Sensotec SC Series of Signal Conditioners/Indicators are available in several different chassis models. In general, each chassis model operates in an identical fashion and can be ordered with any type of Input channels, Output channels, or Virtual channels.

Input channels and Output channels are printed circuit boards that occupy a physical slot inside the instrument's chassis. 12-pin connectors are located on the rear panel to connect to each Input or Output Channel. Each channel in the instrument is identified by a number (channel 01, channel 02, etc.).

A Virtual channel exists in software only; it does not occupy a physical slot inside of the instrument's chassis. There is no rear-panel connector for a Virtual channel. However, a Virtual channel does require a channel number.

4.2 Specifications

	Model SC1000	Model SC2000	Model SC2001	Model SC3004
GENERAL				
# Physical channels	1 to 4	1 to 4	1 to 4	1 to 14
# Virtual channels	8	8	8	8
Case Material	Aluminum	Aluminum	Aluminum	Aluminum
PHYSICAL				
Form factor	3/8 DIN	3/8 DIN	suitcase	2U rack
Mounting	bench, panel or rack		portable	rack
DISPLAY				
# characters/line	16	16	16	20
# lines/display	2	2	2	4
# displays	1	1	1	1, 2 or 3
Display type	Vacuum Fluorescent	Vacuum Fluorescent	Vacuum Fluorescent	Vacuum Fluorescent
ENVIRONMENTAL				
Storage temp.	-30° C to 90° C	-30° C to 90° C	-30° C to 90° C	-30° C to 90° C
Operating temp.	5° C to 40° C	5° C to 40° C	5° C to 40° C	5° C to 40° C
Relative Humidity	80% max. for temperatures up to 31° C; decreasing linearly to 50% max. at 40° C			
Other	indoor use at altitudes up to 2000 m; Pollution Degree 2; Overvoltage Category II			
SPECIAL FEATURES				
Limits Quantity	N/A	4 std., 16 max.	4 std., 12 max.	4 std., 16 max.
Digital, isolated control inputs	N/A	4	4	4
POWER				
Standard AC powered (automatic selection)	100 to 230 VAC, 47 to 63Hz	100 to 230 VAC, 47 to 63Hz	100 to 230 VAC, 47 to 630Hz	100 to 230 VAC, 47 to 63Hz
Optional Vehicle Powered	11-28 VDC, 20W	11-28VDC, 20W	11-28 VDC, 20W	N/A
Total Excitation Drive	120 mA max.	120 mA max.	120 mA max.	400 mA max.

4.3 Models SC1000 and SC2000

4.3.1 Differences Model SC1000 instruments do not include peak/valley capture or limits features. All other SC instruments include peak/valley capture and 4 limit (“alarm”) outputs.

4.3.2 External Arrangement The external arrangement of the AC powered SC1000 and SC2000 is given below.

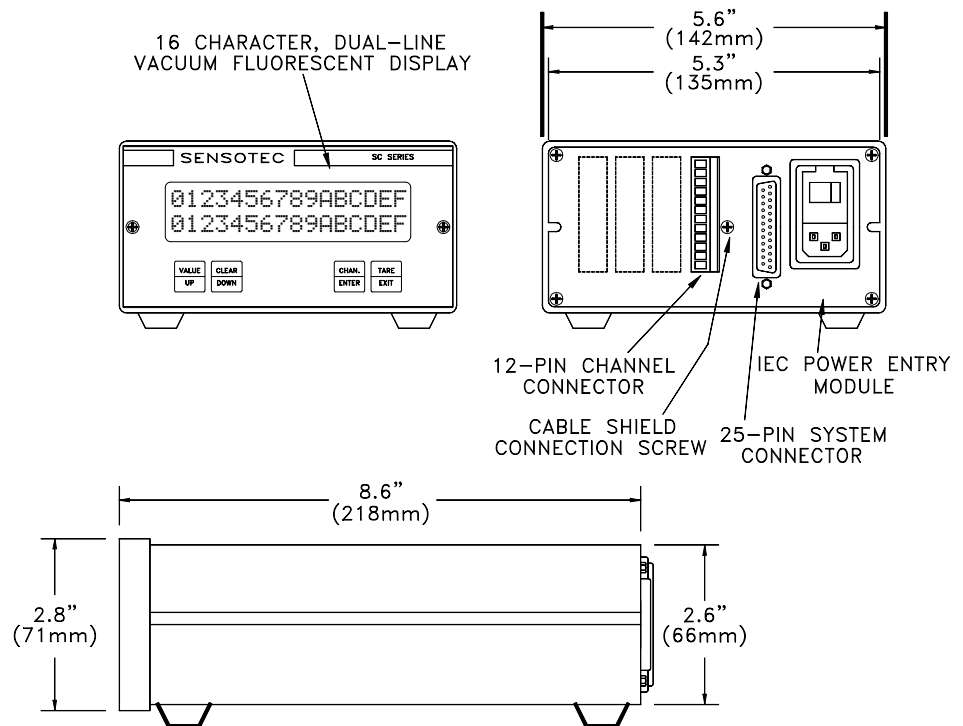

Figure 4-1: External Arrangement of AC powered SC1000 and SC2000

4.3.3 Rear Panel The pinout for the 25-pin System connector is provided later in this chapter. The pinouts for the individual channels are located in the chapter for that channel.

4.3.4 Panel Mounting The panel cutout size conforms to the 3/8 DIN standard. Panel-Mounting Jacks (order code AA928) are available that slide into two slots at the sides of the instrument. Use the following procedure to mount an SC1000 or SC2000 into a panel.

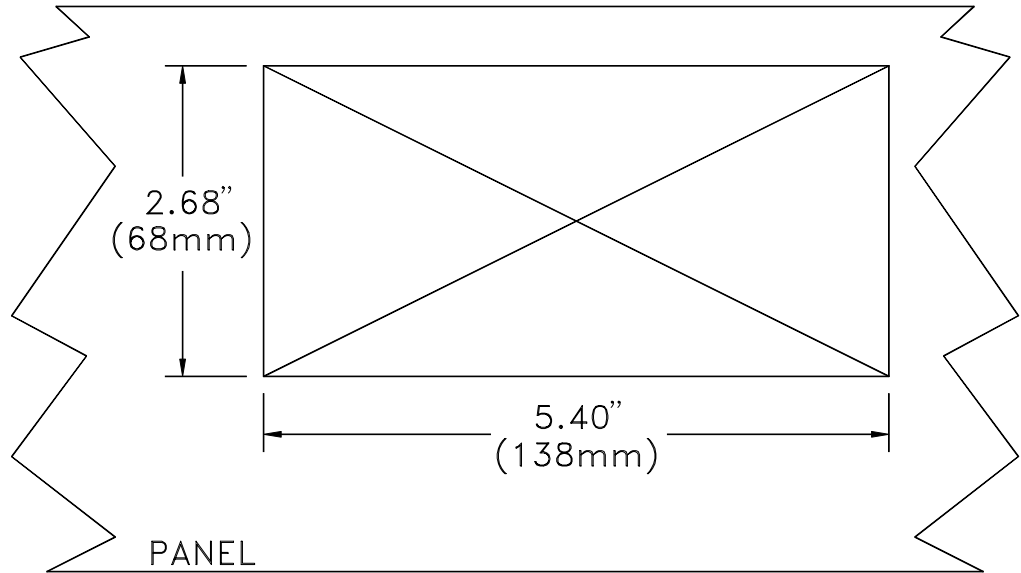

Figure 4-2: Panel Cutout Drawing for SC1000 & SC2000 (not to scale)

- In the panel or rack, cut a hole as shown above. The panel may be up to 1/4" in thickness.
- Use an 0.062" Allen wrench to remove two set screws that hold the Panel-Mounting Jacks to the case. To do this, insert the wrench into the side slots at the rear. Remove the screws completely.
- Remove the Panel-Mounting Jacks by sliding them toward the rear. If the jacks don't slide easily, tap them gently.
- Put the instrument through the hole in the panel.
- Reinsert the Panel-Mounting Jacks into the slide slots. Slide them as far toward the panel as possible.
- Reinsert the setscrews and tighten them. This will force the Panel-Mounting Jacks toward the rear side of the panel, drawing the instrument tightly into place.

4.3.5 Rack Mounting

A Rack Mounting Kit (order code AA934) is available for mounting a single SC1000 or SC2000 into a 19", 2U rack. It includes the Panel-Mounting Jacks described above as well as the 19" rack panel.

4.3.6 Bench Mounting

If bench mounting the instrument, you may want the optional carrying handle/bench stand (order code AA926).

4.3.7 Case Removal

Be sure to remove the power cord from the power source before attempting to remove the instrument from its case.

Use a #0 Phillips screwdriver on the black screws to avoid damaging them.



Removal of rear panel

The rear panel must be removed in order to install or remove channels.

Remove of case from entire circuit board assembly

Step 1: Remove the four black Phillips-head machine screws that secure the back panel of the instrument to the case. These screws are located on the rear of the case, one at each of the four corners.

Step 2: Remove the cable shield connection screw to allow the installation or remove of channels per “Input or Output Channel Installation Procedure” on page 42.

Step 1: Remove the two Phillips-head screws that secure the front panel.

Step 2: Remove the front panel and disconnect its two connecting cables.

Step 3: Remove the four black Phillips-head machine screws that secure the back panel of the instrument to the case. These screws are located on the rear of the case, one at each of the four corners. Do not remove the cable shield connection screw in the center.

Step 4: The circuit boards will slide out of the rear of the case as a unit.

4.3.8 Internal Arrangement

The figure below shows the names and locations of the printed circuit boards.

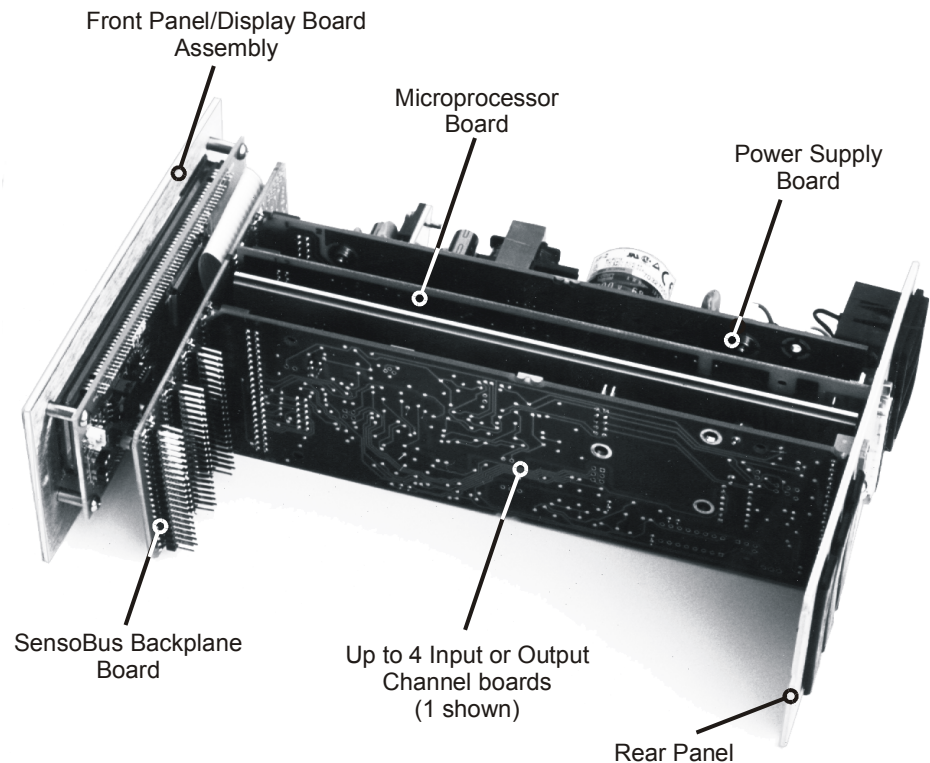

Figure 4-3: Internal Arrangement of SC1000 and SC2000

Below is a description of each printed circuit board.

- The **SensoBus Backplane Board** serves as the connection between all boards in the instrument.
- The **Front Panel/Display Board Assembly** contains the display and all front panel controls.
- The **Power Supply Board** contains the +15V, -15V and +5V power supplies.
- The **Microprocessor Board** contains the microprocessor, ROM software storage chip, and the System connector.
- The **Hardware Input/Output Channel Boards** plug into the remaining four

slots of the SensoBus Backplane Board.

4.3.9 Cleaning

Turn off the instrument and unplug all connectors. Use a soft cloth or tissue and a mild cleaner. Do not use liquid or aerosol cleaners. Do not allow any cleaner inside the instrument.

4.3.10 Vehicle Power Option

Model SC1000 and SC2000 instruments are available with a vehicle power option for operation with batteries and linear DC power supplies. See "Specifications" on page 26 voltage and power requirements.

Due to the momentary startup inrush current of the instrument's power supply, the use of switching power supplies with the SC are not recommended.

4.3.11 Fuse Replacement

The power-line fuses of AC-powered instruments are located within the instrument's power entry module on the rear panel. Use two 2A, 250V fast-blow fuses (Sensotec p/n 029-3026-00).

4.4 Model SC2001

4.4.1 Differences Model SC2001 instruments are SC2000 instruments housed in a portable case.

4.4.2 External Arrangement The external arrangement of the AC powered SC2001 is given below

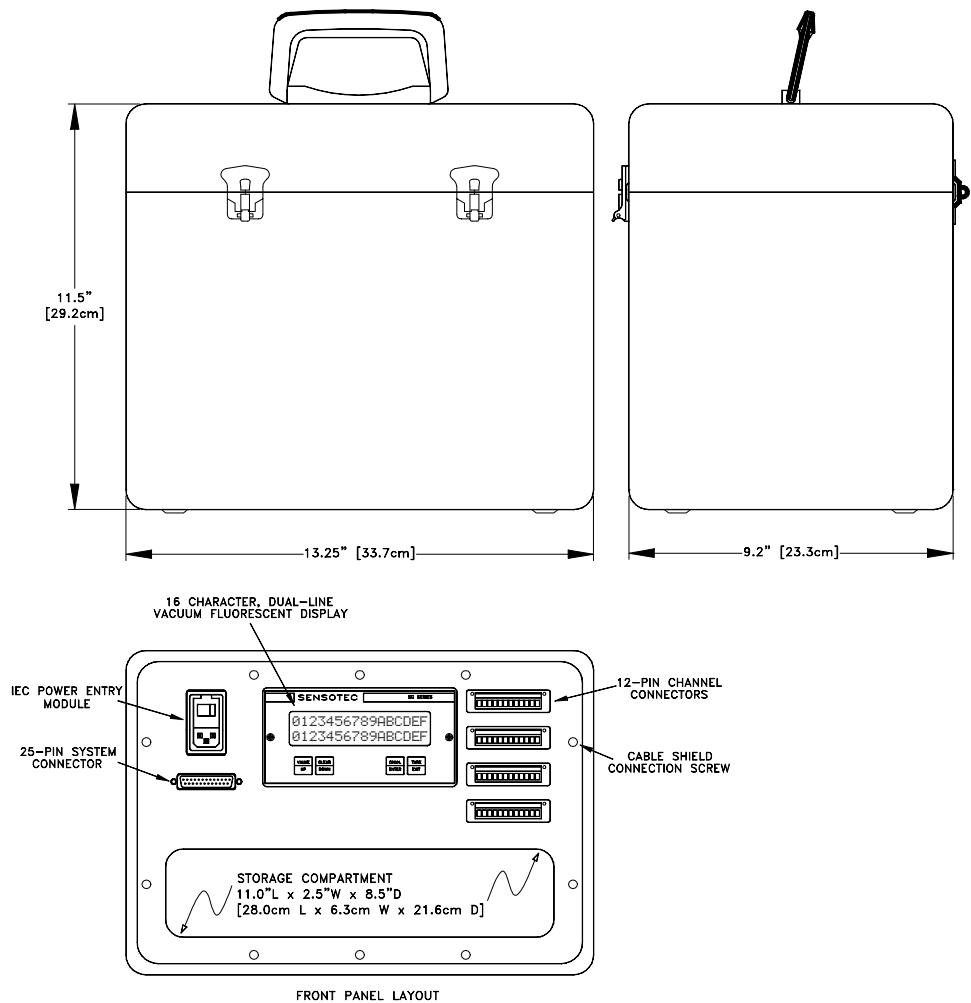

Figure 4-4: External Arrangement of AC powered Model SC2001

4.4.3 Front Panel The pinout for the 25-pin System connector is provided later in this chapter. The pinouts for the individual channels are located in the chapter for that channel.

4.4.4 Case Removal Be sure to remove the power cord from the power source before attempting to remove the instrument from its case.

Step 1: Remove the 10 Phillips-head machine screws that secure the front panel to the case.

Step 2: Pull the front panel assembly out of the case.

Step 3: Proceed with Model SC2000 “Case Removal” on page 28.

4.4.5 Internal Arrangement

See the Model SC2000 “Internal Arrangement” on page 29.

4.4.6 Cleaning

Turn off the instrument and unplug all connectors. Use a soft cloth or tissue and a mild cleaner. Do not use liquid or aerosol cleaners. Do not allow any cleaner inside the instrument.

4.4.7 Vehicle Power Option

The Model SC2001 is available with a vehicle power option for operation with batteries and linear DC power supplies. See “Specifications” on page 26 voltage and power requirements.

Due to the momentary startup inrush current of the instrument's power supply, the use of switching power supplies with the SC are not recommended.

4.4.8 Fuse Replacement

The power-line fuses of AC-powered instruments are located within the instrument's power entry module on the rear panel. Use two 2A, 250V fast-blow fuses (Sensotec p/n 029-3026-00).

4.5 Model SC3004

4.5.1 External Arrangement

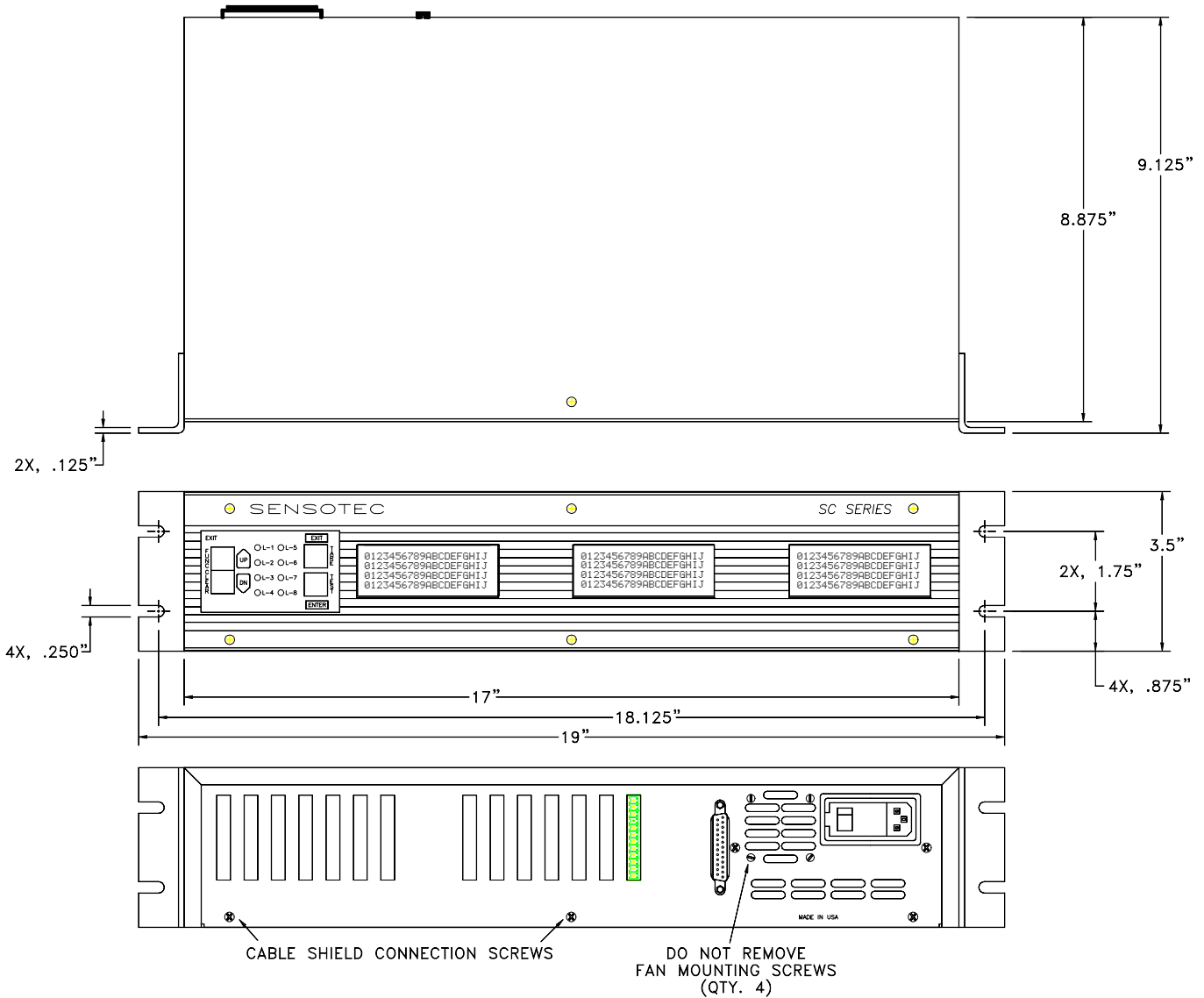

Figure 4-5: External Arrangement of Model SC3004

4.5.2 Rear Panel

The pinout for the 25-pin System connector is provided later in this chapter. The pinouts for the individual channels are located in the chapter for that channel.

4.5.3 Panel Mounting

The panel space necessary conforms to the EIA 19" rack-mount standard. Panel mounting ears are attached to the instrument.

4.5.4 Bench Mounting

Panel mounting ears are attached to the instrument, and may be removed if they are not needed.

4.5.5 Case Removal

Be sure to remove the power cord from the power source before attempting to remove the case from the instrument.



Use a #0 Phillips screwdriver on all screws to avoid damaging them.

Step 1: Remove the four, silver rack-mounting ears from the left and right sides.

Step 2: Remove one Phillips screw from the top of the case.

Step 3: Remove two Phillips screws from the bottom of the black case cover.

Step 4: Remove the black case cover from the instrument.

Step 5: Remove eight Phillips screws from the rear panel, including the two cable shield connection screws. NOTE: Do not remove the four screws which secure the cooling fan to the rear panel.

Step 6: Remove the rear panel.

4.5.6 Rear Panel

The pinout for the 25-pin System connector is provided later in this chapter.

4.5.7 Internal Arrangement

User installable printed circuit boards will slide out of the rear of the case once the case and rear panel have been removed as described above.

4.5.8 Cleaning

Turn off the instrument and unplug all connectors. Use a soft cloth or tissue and a mild cleaner. Do not use liquid or aerosol cleaners. Do not allow any cleaner inside the instrument.

4.5.9 Fuse Replacement

The power-line fuses are located within the instrument's power entry module on the rear panel. Use two 2A, 250V fast-blow fuses (Sensotec p/n 029-3026-00).

Chapter 5

System Connector

5.1 Introduction

The 25-pin D-subminiature System connector is used for the following:

- Communication by RS-232 or RS-485. RS-232 DCE standard designations have been maintained.
- Digital Function Inputs, such as for resetting tare, peak and latched limits
- Open-collector digital Limit Outputs for limits 1 through 4 (not available on Model SC1000).

5.2 System Connector Pinout

Table 5-1: System Connector

Pin	Name	Function	Input/Output	Reference Pin
1	N/C	No Connection	N/A	
2	RS-232 IN	RS-232 Data In	Input	7
3	RS-232 OUT	RS-232 Data Out	Output	7
4	CTS	RS-232 Clear to Send (connected to pin 5)	N/A	N/A
5	RTS	RS-232 Request to Send (connected to pin 4)	N/A	N/A
6	DSR	RS-232 Data Set Ready	Output	7
7	GND	RS-232/RS-485 reference	Reference	-
8	DCD	RS-232 Data Carrier Detect (not connected)	N/A	N/A
9	FUNC 2	Function Input #2: Clear Peak/Valley & Limits	Input	19
10	FUNC 1	Function Input #1: Tare Off for all channels	Input	19
11	FUNC 0	Function Input #0	Input	19
12	RS-485 TB	RS-485 Transmit B	Output	7
13	RS-485 TA	RS-485 Transmit A	Output	7
14	L1	Limit 1 Output (Open Collector)	Output	19
15	L2	Limit 2 Output (Open Collector)	Output	19
16	L3	Limit 3 Output (Open Collector)	Output	19
17	L4	Limit 4 Output (Open Collector)	Output	19
18	N/C	No Connection	N/A	
19	DGND	DGND (Digital Ground)	Reference	
20	DTR	RS-232 Data Terminal Ready (not connected)	N/A	N/C
21	FUNC 3	Function Input #3: Tare On for all channels	Input	19
22	RI	RS-232 Ring Indicator (pulled up to 5V)	Output	
23	N/C	No Connection	N/A	N/C
24	RS-485 RB	RS-485 Receive B	Input	7
25	RS-485 RA	RS-485 Receive A	input	7

The Limit Output pins and Function Input pins are electrically isolated from the rest of the instrument.

The RS-232 and RS-485 communications pins are electrically isolated from the rest of the instrument.

The RS-232 and RS-485 interfaces are exclusive; an instrument cannot have both.

5.3 Function Input Pins

5.3.1 Overview To use a Function Input pin (9, 10, 11 or 21), connect it to the DGND (pin 19) momentarily. This can be accomplished by a push button switch, relay contact closure, or PLC output.

Usually, the Function Input pins perform the default actions described in the “System Connector Pinout” on page 36. However, a SensoCode program running on a Mathematics Virtual Channel may replace these default actions. Consult the Customer Information Sheet included with your instrument for details.

5.3.2 Example For example, assume that you wish to use Function Input #3 to tare all channels in the instrument simultaneously. Connect a push-button switch as shown below.

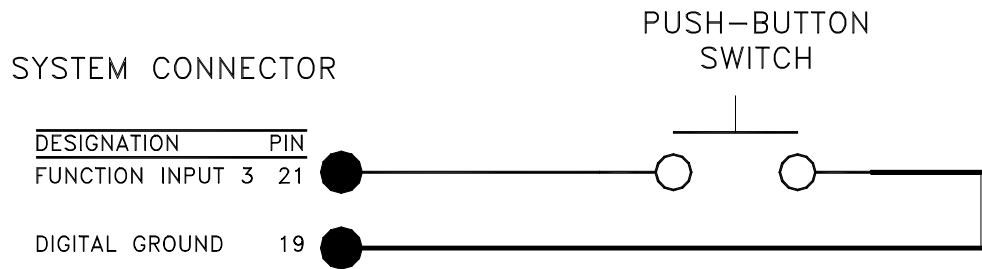

Figure 5-1: Function Input Example

5.4 Limit Output Pins

5.4.1 Overview

An open-collector output is a transistor logic output that can be used to control DC loads, drive opto-isolators or relays, or interface directly to logic circuitry. They act very much like switches: low resistance when turned on and high resistance when turned off. You can use them as you would a dry relay contact, with the following restrictions:

- The voltage applied must be DC
- The polarity of the DC voltage must be observed
- Maximum voltage: 50VDC
- Maximum power: 2.0W

When Limits 1, 2, 3, or 4 are activated, the corresponding open-collector Limit Output pin on the System connector will be connected to the DGND (Digital Ground) pin. However, a SensoCode program running on a Mathematics Virtual Channel may override this behavior. Consult the Customer Information Sheet included with your instrument for details.

5.4.2 Example

For example, assume that a remote indicator is to be lighted when Limit 1 is activated. An external 24 VDC power supply connects to the indicator.

When Limit 1 is deactivated, there is high resistance between the Limit 1 Output pin and the DGND (Digital Ground) pin; little current flows in the circuit and the light is off. When Limit 1 is activated, there is low resistance between the Limit 1 Output pin and the DGND (Digital Ground) pin; the light turns on.

The resistor limits the current flowing in the circuit when the light is lighted to 48 mA. According to Ohm's Law:

$$I = \frac{V}{R}$$

$$48\text{mA} = \frac{24\text{V}}{500\Omega}$$

Lights or other indicators have voltage, current, and/or power ratings that must be observed in order to avoid damaging them.

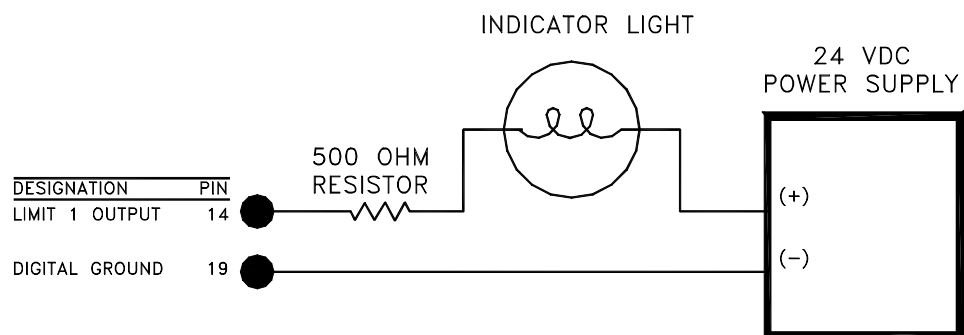

Figure 5-2: Open-Collector Output Example

Chapter 6

System Menu

6.1 Overview

The System menu allows you to examine and change settings that affect the chassis of the SC instrument. You can view the internal software revision and the instrument's configuration (i.e. what types of cards are installed in each channel).

Detailed instructions on operating the SC instrument in the SETUP Menu mode can be found in "SETUP Menu mode" on page 23. A diagram of all menus is located in the "Setup Menu Reference" on page 155.

6.2 Menu Items

6.2.1 SOFTWARE REVISION Menu Item

This displays the software part number and revision that is resident in the Micro-processor Board of the SC instrument.

6.2.2 CONFIGURATION Sub- Menu

When selected, a sub-menu is displayed which lists all available channels in an SC Series instrument. By pressing [ENTER] when a channel number is displayed, the card type installed in that channel is shown. If a card is not installed in that channel, the message "NOT INSTALLED" is shown. Press [ENTER] again to return to the sub-menu listing of all channels.

6.2.3 DIAGNOSTICS Sub- Menu

This sub-menu allows exercising and monitoring of the System connector's output and input pins.

OUTPUT TEST Sub-Menu

Select an output pin to turn "on" (connected to pin 19) or "off" (disconnected from pin 19). The output pins are updated immediately.

INPUT TEST Menu Item

When this item is selected, the status of all four digital inputs are continuously scanned and displayed. A "0" means that an input is not connected to pin 19 (not asserted), and a "1" means that it is connected (asserted). Press any button to exit this operation.

SCAN TIME Menu Item

When selected, this menu item displays the time, in seconds, that it last took for the chassis to service all of the channels. In the RUN mode, the chassis reads each channel's track, peak and valley value sequentially. After each channel has been serviced, the limits are processed.

The value displayed is obtained from the last execution of the RUN mode prior to entering the SETUP menu mode. If you enter the SETUP mode immediately after power up, the display will read "NOT AVAILABLE".

6.2.4 INSTALL CHANNEL Menu Item

This menu item will add an Input, Output or Virtual channel as the next highest channel number in the system.

Installing a channel will cause it to use the “default” or “empty” configuration information for that channel. Any calibration data, SensoCode mathematics programs, display setup, or other information will be erased to default values! All other channels are unaffected.

Input or Output Channel Installation Procedure



Before installing an Input or Output card, make certain that you know the “card type” (a two-digit hexadecimal number) of the card you wish to install.

Use Electrostatic Discharge (ESD) precautions when unpacking and handling circuit boards.

Use the following procedure to install an Input or Output card:

- 1) When the instrument is in the RUN mode, use the [ENTER] button to change which channel the display is monitoring. Note the highest channel number that is presently installed. The new circuit card for the new channel will be installed as the next channel number.
- 2) Examine the circuit card to be installed and orient it as shown below. On it you will find the address jumper block.

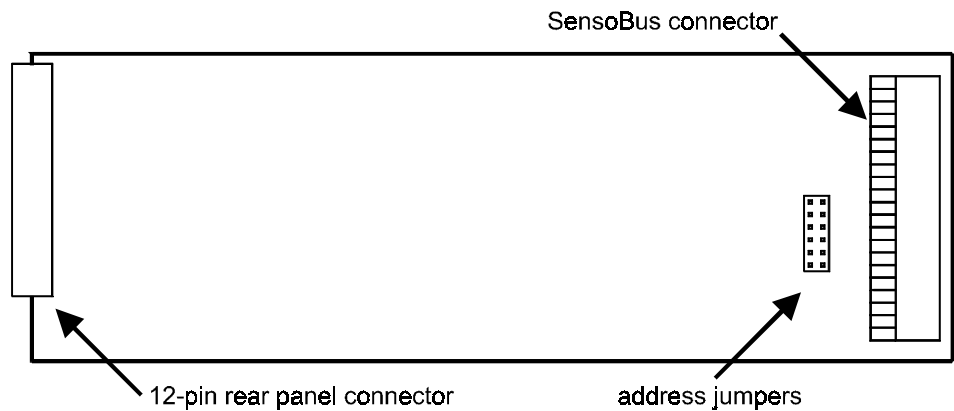

Figure 6-1: Address Jumper Block Location

- 3) Change **both** address jumpers to match the next available channel in the instrument according to the chart below. Do not skip any channel numbers.

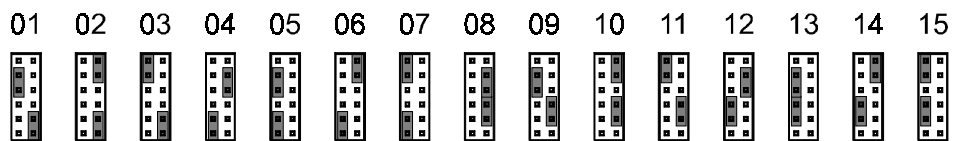

Figure 6-2: Address Jumper Settings

Input Channels, Output Channels and Virtual Channels (such as Mathematics Channels and Split Display Channels) all require an unique address.

- 4) Turn the instrument off and remove the power cord from the power source.
- 5) Find the "Case Removal" in Chapter 4 "Chassis Models" on page 25 that matches the particular chassis model. Follow the directions and remove the rear panel.
- 6) Locate an unused 42-pin SensoBus connector on the SensoBus mother board and make certain that all of its pins are not bent out of shape. It does not matter into which slot you install the card as the addressing is implemented with the address jumpers. However, it is most convenient to match the card's address with the channel numbers silk-screened on the rear panel.
- 7) Install the card into an unused 42-pin SensoBus connector on the SensoBus mother board. Make certain the card is fully seated.
- 8) Replace the rear panel.
- 9) Re-connect the power cord to the power source. Turn the instrument on.
- 10) Enter the SETUP menu mode, then select "SYSTEM MENU -> INSTALL CHANNEL". The instrument will then present a menu of card types available for installation.
- 11) Use the [UP] and [DOWN] buttons to select the card type of the card you wish to install. After you select the card type to be installed, you are asked "ARE YOU SURE?". To cancel this operation, select "NO" or press the [EXIT] button. If "YES" is selected, "WORKING..." is displayed and the installation will commence.
- 12) If the installation was successful, "DONE" will be displayed. If the installation failed, you will see one of the following messages:
 - "SYSTEM IS FULL": There are no unused channels available in the instrument.
 - "WON'T INSTALL": The Output Relay card type you selected to install does not match the next available set of Limits. For example, the Limit 09-12 card type will not install unless the Limit 05-08 card type has been installed.
 - "ERROR 28 ON CH. xx": The instrument could not communicate with the card's EEPROM memory. This is usually caused by the address jumpers being set incorrectly or if the card is not physically inside the chassis.

Virtual Channel Installation Procedure

Use the following procedure to install a Virtual Channel:

- 1) Enter the SETUP menu mode, then select "SYSTEM MENU -> INSTALL CHANNEL". The instrument will then present a menu of card types available for installation.
- 2) Select the card type of the card you wish to install. After you select the card type to be installed, you are asked "ARE YOU SURE?". To cancel this operation, select "NO" or press the [EXIT] button. If "YES" is selected, "WORKING..." is displayed and the installation will commence.
- 3) If the installation was successful, "DONE" will be displayed. If the installation failed, you will see one of the following messages:
 - "CAN'T INSTALL": There is no more memory available for Virtual channels.
 - "SYSTEM IS FULL": There are no unused channels available in the instrument.

After installing a Mathematics Virtual channel, you must re-load the SensoCode program into the channel with a computer running the Sensotec "Instrument Utility Software". See "Mathematics Virtual Channel" on page 141 for more information.

6.2.5 DELETE CHANNEL Menu Item

This menu item will delete the last channel in the instrument. Before deletion occurs, the number of the channel to be deleted is displayed and you are asked "ARE YOU SURE". To cancel this operation, select "NO" or press the [EXIT] button. If "YES" is selected, the last channel in the system will be deleted.

After a hardware channel has been deleted, you can safely physically remove it from the chassis. See "Case Removal" on page 28 for SC1000 and SC2000 instruments. See "Case Removal" on page 34 for SC3004 instruments.

Re-installing a deleted channel will erase all of its configuration information!

6.2.6 DEFAULT CHANNEL Menu Item

This menu item will reset all settings for the channel you select to their factory default values. Before the channel settings are reset, you are asked "ARE YOU SURE?". To cancel this operation, press the [EXIT] button. If "YES" is selected, the channel's settings will be reset.

Defaulting a channel is an operation that cannot be undone. All calibration information and other settings will be erased.

Chapter 7

Serial Communications

7.1 Overview

The SC Series instruments are designed to communicate with a remote computer system or terminal for the purpose of transferring data values from the instrument to the remote system. The remote computer or terminal also can control many of the functions performed by the instrument.

This chapter is a brief introduction to serial communications with SC Series instruments. A separate instruction manual is available to assist with the hookup and wiring for data communications as well as provide detailed information of all the available commands. Ask for manual 008-0610-00, "SC Series Communications Guide" or download it from Sensotec's web site, www.sensotec.com.

7.2 Rear Panel Connector

The System connector on the instrument's rear panel is used, among other things, for serial communications. See "System Connector" on page 35 for wiring information.

All of the serial communications pins on the 25-pin System connector have 500V of electrical isolation from all other pins and connectors on the instrument. Additionally, all serial communications pins are protected against electrostatic discharge (ESD).

7.3 Communications Protocol

7.3.1 RS-232 vs. RS-485

SC Series instruments are available with either of two communications protocols, RS-232 or RS-485. Only one of these can be installed at a time at the factory.

- RS-232 provides for only one receiver and transmitter per loop, and a loop length of no more than 50 feet.
- RS-485 allows up to 32 devices per loop, and a loop length of no more than 4000 feet. All devices receive messages in parallel on the line, the so-called “multi-drop” system. To avoid garbled transmissions, only one device should respond to a particular message. Therefore, every device on the loop must have a unique address.

If you have an instrument with more than one channel, transmission must be addressed to the appropriate channel within the instrument.

7.3.2 Parameters

All SC instruments use no parity, 8 data bits, and 1 stop bits (“N,8,1”) for serial communications. Baud rates available are 300, 600, 1200, 2400, 4800, 9600, 19200 and 38400. As shipped from the factory, all instruments are set at 9600 baud. The baud rates are selected via the RS-232 or RS-485 and not through the front panel.

7.4 Serial Com. Menu

7.4.1 Overview

The Serial Com menu allows you to examine the settings for serial communications as well as test the communications link. You cannot change the settings for serial communications through the menus; these settings can only be changed via serial communications.

Detailed instructions on operating the SC instrument in the SETUP Menu mode can be found in "SETUP Menu mode" on page 23. A diagram of all menus is located in "Setup Menu Reference" on page 155.

7.4.2 INTERFACE Menu Item

This menu item indicates which serial communications interface is installed in the instrument: "R5-232" or "R5-485".

7.4.3 ADDRESS Menu Item

This allows you to examine the two-character address that the instrument will respond to. The default address of "00" (ASCII codes decimal 30, decimal 30). Please see the "SC Series Serial Communications Guide" for information on using the "W4" command to change the address.

7.4.4 BAUD RATE Menu Item

This allows you to examine the baud rate that the instrument uses for serial communications. The default baud rate is 9600. Please see the "SC Series Serial Communications Guide" for information on using the "W1" command to change the baud rate.

7.4.5 AUTO LINE-FEED Menu Item

This allows you to examine the setting (on/off) of the auto line-feed function. When set to "on", a line-feed character (ASCII code decimal 10) is transmitted just before the carriage return (ASCII code decimal 13) that signifies the end of the instrument's response.

If the instrument is connected to a dumb terminal or printer, inserting a line feed before the carriage return will make each message sent by the instrument appear on a separate line and thus be easier to read.

The default setting is "on".

7.4.6 TRANSMIT TEST Menu Item

When this menu item is selected, the instrument immediately transmits the message "ADDRESS nn TEST" where "nn" is the two-character address of the instrument. Then the message "MESSAGE SENT" is shown on the display. This helps detect wiring or other problems with serial communications from the instrument to the computer or PLC.

7.4.7 LEAVE MENU Menu Item

When the menu item is displayed, press [ENTER] to leave this menu. Press [EXIT] to return to the RUN mode.

Chapter 8

Display Menu

8.1 Overview

The Display menu allows you to examine and change settings that affect the operation of the display of the SC instrument. You can change which channel is displayed when the instrument is powered-up and what information is shown on the lower line of SC1000, SC2000 and SC2001 instruments.

Detailed instructions on operating the SC instrument in the SETUP Menu mode can be found in "SETUP Menu mode" on page 23. A diagram of all menus is located in the "Setup Menu Reference" on page 155.

8.2 Menu Items for Models SC1000, SC2000, SC2001

These instruments have a dual-line display which consists of an upper line and a lower line.

8.2.1 UPPER CHANNEL Menu Item

Specifies the channel that is displayed on the upper line when the instrument is powered-up.

To change whether the channel's track, peak or valley data value is displayed on power-up, use the channel's "OPERATION -> POWER-ON SOURCE" menu item.

8.2.2 LOWER CHANNEL Menu Item

Specifies the channel that is displayed on the lower line when the "LOWER MODE" menu item is set to "CHANNEL".

To change whether the channel's track, peak or valley data value is displayed on power-up, use the channel's "OPERATION -> POWER-ON SOURCE" menu item.

8.2.3 LOWER MODE Menu Item

Determines what is displayed on the lower line. The choices are:

- "BLANK" means that nothing is displayed.
- "LIMIT 01-04" means that the status of Limit 1, Limit 2, Limit 3, and Limit 4 are displayed as described in "Indicator Lights" on page 21
- "CHANNEL" means that the channel specified with the "LOWER CHANNEL" menu item is displayed.

8.2.4 DISPLAY DISABLE Menu Item

Determines if the display is enabled or not. In some applications, the display is not used in order to reduce power consumption; the instrument is then completely controlled with the Serial Communications interface. The choices are:

- "OFF" means that the display operates normally.
- "ON" means that the display is blanked after the instrument is powered up. Pressing any button on the front panel will temporarily re-enable the display until the instrument is reset.

8.3 Menu Items for Model SC3004

8.3.1 POWER-ON CHANNEL Menu Item

Specifies the channel that is selected when the instrument is powered up.

To change whether the channel's track, peak or valley data value is displayed on power-up, use the channel's "OPERATION -> POWER-ON SOURCE" menu item.

9.1 Understanding Limits, Set Points and Return Points

Limits are signal levels at which some action (such as a light to come on or go out, or a switch to close) is desired to take place. The point at which this action takes place is the *SET POINT*. The *RETURN POINT* is the point at which the action that took place at the *SET POINT* returns to its original state.

If the *SET POINT* and *RETURN POINT* are identical and the signal level is changing slowly near these points, “chatter” may result and the limit rapidly energizes and de-energizes. To keep this from happening, we can specify the *SET POINT* at which the action would occur as well as the *RETURN POINT* where we want the action to cease. If the amount of “dead band” between these two values is more than the expected noise, the desired action will take place only once. The *SET POINT* and the *RETURN POINT* should always be separated to insure that small amounts of noise on the signal will not become a problem.

A good general rule for *SET POINT* and *RETURN POINT* values is that they should be separated by at least one percent of the full-scale value.

9.2 Limit Operation

9.2.1 Actions When Activated

When Limits 1, 2, 3, or 4 are activated, the following actions occur:

- The front panel light for the limit will illuminate.
- The corresponding open-collector Limit Output pin on the System connector will be connected to the DGND (Digital Ground) pin.
- If a Relay Output channel is installed, the relay for the limit will activate.

A Relay Output channel can be installed for Limits 5, 6, 7, and 8. When these limits are activated, the following actions occur:

- If the display is monitoring the channel of this Relay Output channel, the display will indicate the status of these limits.
- On a Model SC3004, the front panel light for the limit will illuminate.
- The relay for the limit on this Relay Output channel will activate.

A Relay Output channel can be installed for Limits 9, 10, 11 and 12. When these limits are activated, the following actions occur:

- If the Relay Output channel is displayed, the display will indicate the status of these limits.
- The relay for the limit on this Relay Output channel will activate.

A Relay Output channel can be installed for Limits 13, 14, 15 and 16. When these limits are activated, the following actions occur:

- If the Relay Output channel is displayed, the display will indicate the status of these limits.
- The relay for the limit on this Relay Output channel will activate.

9.2.2 Scan Time

The “scan time” or update rate of the limits depends on how many channels are installed in the instrument. To determine the scan time of the limits for your particular instrument, see “SCAN TIME Menu Item” on page 41.

9.3 Limit Menus

9.3.1 Overview

There are four, eight, twelve or sixteen Limit menus depending on how many Relay Output channels are installed in the instrument. These menus determine the operation of the each of the limits.

If no Relay Output channels are installed, there are four Limit menus which control the operation of the open-collector Limit Outputs on the System connector.

Detailed instructions on operating the instrument in the SETUP Menu mode can be found in "SETUP Menu mode" on page 23. A diagram of all menus is located in "Setup Menu Reference" on page 155.

9.3.2 LIMIT. ENABLE Menu Item

This enables or disables the operation of this limit. The two options for this menu item are "ON" and "OFF".

9.3.3 LIMIT. SETPOINT Menu Item

This is the numeric value in engineering units for the signal level that activates the limit.

9.3.4 LIMIT. RETURN PNT Menu Item

This is the numeric value at which the limit deactivates. In general, this number should differ from the set point values by at least 1% of full scale.

Carefully consider what value should be entered for the *RETURN POINT*. If the signal is expected to approach the *SET POINT* from a lower value, the *RETURN POINT* value should be less (algebraically) than the *SET POINT*. If the signal is expected to approach the *SET POINT* from a higher level, the *RETURN POINT* should be higher (algebraically) than the *SET POINT*.

9.3.5 LIMIT. ENERGIZE Menu Item

This specifies when to activate the limit relative to the set point and return point.

The options for this menu item are:

- "SIGNAL > SETPOINT" means the limit will activate when the signal is higher than the set point.
- "SIGNAL < SETPOINT" means the limit will activate when the signal is lower than the set point.
- "SIGNAL INSIDE" means the limit will activate when the signal is in between the set point and the return point.
- "SIGNAL OUTSIDE" means the limit will activate when the signal is not in between the set point and the return point.

The figures below further illustrate the differences between these settings.

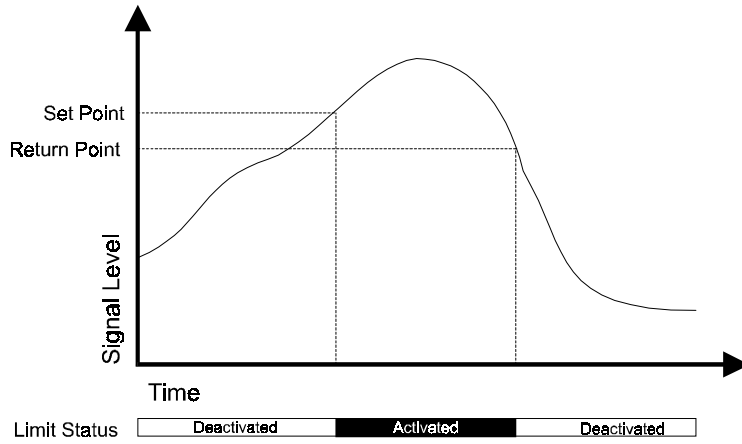

Figure 9-1: Limit Operation when $LIMIT. ENERGIZE = SIGNAL > SETPOINT$

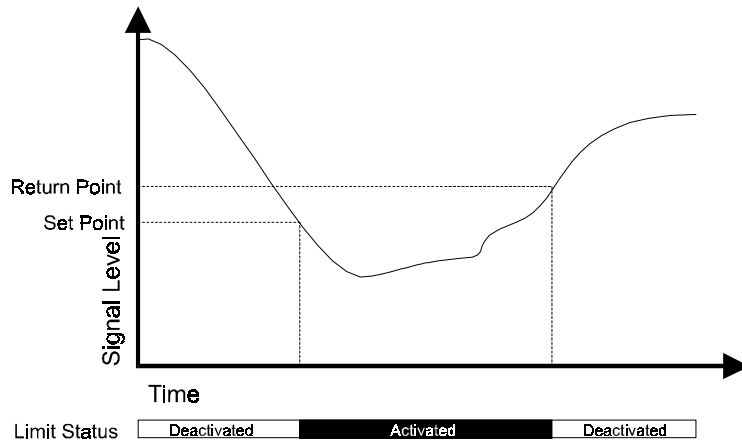

Figure 9-2: Limit Operation when $LIMIT. ENERGIZE = SIGNAL < SETPOINT$

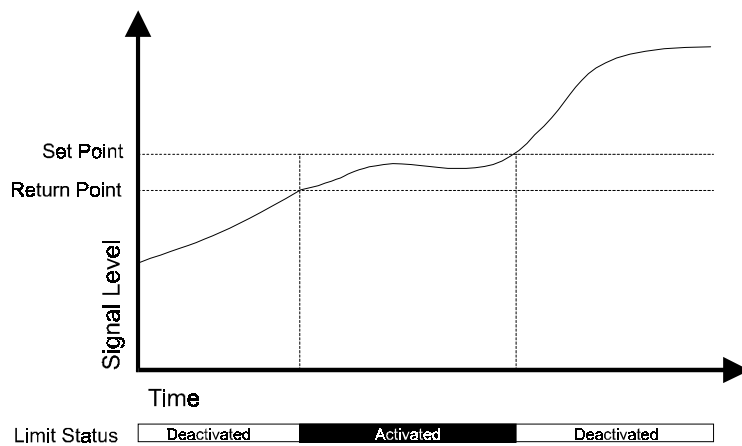

Figure 9-3: Limit Operation when $LIMIT. ENERGIZE = SIGNAL$ INSIDE

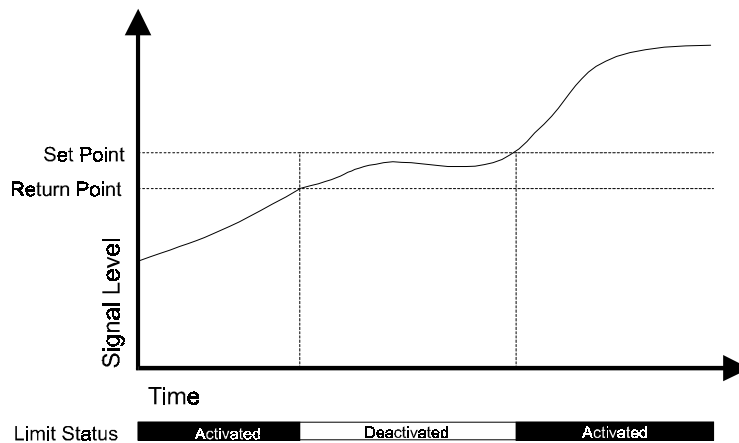

Figure 9-4: Limit Operation when LIMIT. ENERGIZE = SIGNAL OUTSIDE

9.3.6 LIMIT. LATCHING Menu Item

This specifies whether to latch the activated limit so that only manually clearing the limit will deactivate it. A latched limit can be manually cleared by pressing the [CLEAR] button, sending the “F8” serial communications command, or by using the Function Input #2 (Clear Peak/Valley & Limits pin on the System Connector. See “Function Input Pins” on page 37.

The options for this menu item are:

- “ON” means that once a signal activates the limit, the limit will remain activated until it is reset.
- “OFF” means that the limit will deactivate immediately when the signal crosses the return point.

9.3.7 LIMIT. CHANNEL Menu Item

This specifies the channel that is monitored by this limit.

9.3.8 LIMIT. SOURCE Menu Item

This designates the data source of the channel monitored by this limit. Each channel has three data sources: the live tracking value (TRACK), its highest value (PEAK), and its lowest value (VALLEY).

The options for this menu item are:

- “TRACK” means the live tracking value of the channel.
- “PEAK” means the highest value of the channel since the peak/valley detector was last cleared.
- “VALLEY” means the lowest value of the channel since the peak/valley detector was last cleared.

9.3.9 LEAVE MENU Menu Item

When the menu item is displayed, press [ENTER] to leave this menu. Press [EXIT] to return to the RUN mode.

Chapter 10

Strain-Gage Input Channel

10.1 Features

The Strain-Gage Input channel provides a DC excitation voltage to and accepts millivolt signals from strain-gage transducers. These millivolt signals are digitized, converted into engineering units, and placed into the track, peak and valley data values of the channel. Setup and calibration of the channel can be made manually through the SETUP mode or automatically if the transducers are equipped with *Signature Calibration*. See “What is Signature Calibration?” on page 14.

The analog-to-digital converter input circuit is ratiometric to the excitation voltage, features adjustable digital, low-pass filtering, 12- to 18-bit resolution (depending on the filter setting) and has several different mV/V input ranges. These many input ranges allow $\pm 50,000$ count resolution (at the slowest filter setting) across a wide variety of mV/V input ranges.

Three methods of calibrating the Strain-Gage Input channel to the transducer are available: known-load calibration, shunt calibration and mV/V calibration. The benefits of each are discussed in “CALIBRATION TYPE Menu Item” on page 67.

Two rear panel control inputs can be field-configured for such functions as remote tare, disabling peak/valley detection and clearing the peak/valley values. A voltage or current digital-to-analog output is also provided.

Many diagnostic functions are performed automatically to insure correct wiring and operation of the transducer.

FP2000 Transducers

The Strain-Gage Input channel has its own internal shunt resistor for use in Shunt Calibration. It is not compatible with FP2000 mV/V output transducers that are equipped with “Buffered Shunt Calibration”. If you wish to use Shunt Calibration with an FP2000 transducer, use an FP2000 with Buffered Shunt cal and amplified output (e.g. 5 VDC, 10 VDC or 4-20mA) connected to an SC's High-Level Input channel.

10.2 Wiring

Connect the transducer to a Strain-Gage Input channel by wiring it to the 12-pin connector of that channel. The Customer Information Sheet that shipped with the instrument describes which cards are installed in each channel. The pin-out for this connector is shown on the following table.

Table 10-1: Strain-Gage Input Channel Pin Connections

Pin	Label	Function	Reference Pin
1 (top)	+EXC	(+)Excitation	10
2	+SEN	(+)Sense	10
3	-SEN	(-)Sense	10
4	-EXC	(-)Excitation	10
5	+SIG	(+)Signal	10
6	-SIG	(-)Signal	10
7	+OUT	Analog Output	8
8	-OUT	Analog Return	-
9	+MEM	(+)Signature	10
10	-MEM	(-)Signature / Digital Ground	-
11	AUX1	Auxiliary Function 1 (connect to pin 10 to activate)	10
12 (bottom)	AUX2	Auxiliary Function 2 (connect to pin 10 to activate)	10

The Analog Output and Analog Return pins are electrically isolated from all other pins on the instrument.

The maximum recommended cable length to a Signature Module is 100 feet [30m].

If you are not using remote sensing of excitation, jumper (+)Sense to (+)Excitation and (-)Sense to (-)Excitation. If nothing is connected to (+)Sense and (-)Sense, the instrument will enter the ERROR mode with error code 46.

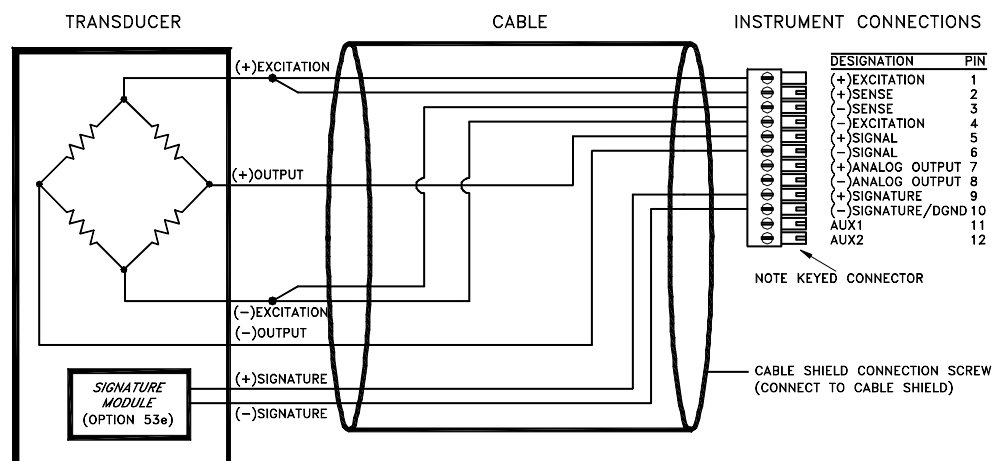

Figure 10-1: Unamplified Transducer Connection to Strain-Gage Input Channel

10.3 Calibration Procedure

If you are not familiar with operating the instrument in the SETUP menu mode, see “SETUP Menu mode” on page 23. A listing of all menu items is given in “Setup Menu Reference” on page 155.

Step 1: Wire the transducer to the channel’s connector.
See “Wiring” on page 60 for details.

Step 2: Enter the CALIBRATION TYPE.

There are three methods that can be used to calibrate the transducer to the Input Channel. Each has advantages and disadvantages as described in the CALIBRATION TYPE menu item section. It is important to know your application in order to select the appropriate calibration type.

Step 3: Enter the CALIBRATION DATA.

If your transducer has *Signature Calibration*, you don’t need to enter these values as they are entered automatically.

If your transducer was ordered and shipped along with the instrument, you don’t need to enter these values as they have been entered at the factory.

Otherwise, consult the Certificate of Calibration for the transducer when entering information in the CALIBRATION DATA sub-menu.

Step 4: Perform the calibration.

Otherwise, use the CALIBRATE menu item starts the calibration process. You will be prompted to apply loads to the transducer as required.

10.4 Specifications

TRANSDUCER INPUT

Transducer type	full-bridge, strain gage
Excitation Voltage	5 or 10 VDC, short circuit protected with sensing
Transducer full-scale output	.5 to 21 mV/V @ 5V excitation .5 to 10.5 mV/V @ 10 V excitation
Amplifier Gain Selection	automatic
Calibration Type	shunt, mV/V or 2-, 3- or 5- point known load
Differential Input Voltage	+/- 105mV (max.)
A/D Converter	24-bit Sigma-Delta
Low-pass filter	digital, 24-tap FIR
Resolution and Frequency Response	see "FREQ. RESPONSE Menu Item" on page 63

INSTRUMENT-ONLY ACCURACY

(Sense wires used; Frequency Response setting <= 16Hz;
Linearity, repeatability & hysteresis)

mV/V Calibration	±0.1% F.S.
Known -Load Calibration	±0.01% F.S.

AUXILLIARY INPUTS

Quantity	2
Type	momentary contact closure
Response Time	< 5ms
Field-Selectable Functions	tare on, tare off, peak/valley clear, peak/valley hold, track hold

ANALOG OUTPUT

Output voltage range	5, ±5, 10 or ±10 VDC (field selectable)
Output current range (optional current output channels)	4-20 mA
Source	any channel's track, peak or valley value
Isolation	500V
Resolution	13 bits
Frequency Response	same as input when driven by the same channel's tracking data

10.5 Channel Menu

Each Strain-Gage Input channel is configured and calibrated via its channel menu. Detailed instructions on operating the instrument in the SETUP Menu mode can be found in "SETUP Menu mode" on page 23. A diagram of all menus is located in "Setup Menu Reference" on page 155.

10.5.1 OPERATION Sub-Menu

This menu controls the operation of this channel when the instrument is in the RUN mode.

AUTO-ZERO Menu Item

This enables or disables the channel's automatic zeroing function. The auto-zero function can be beneficial by removing the effect of slight temperature shifts in the transducer's output. The two options for this menu item are "ON" and "OFF".

When enabled, the channel will reset its tracking value to zero when the tracking value has never been more positive than +10 or more negative than -10 display counts for any 10 second period.

For example, assume that the DISPLAY.DECPT menu item is set to 000.00 (two decimal points). If the tracking value never leaves the range of -000.10 to +000.10 for any 10 second period, then tracking value will reset to 000.00 automatically.

To compensate for the transducer's initial warm-up shift, the auto-zero function operates every 2 seconds during the first 60 seconds of RUN mode operation.

FREQ. RESPONSE Menu Item

This sets the frequency response, step response, and resolution of the channel according to the table below. The tracking value, peak/valley detector values and analog output on this channel are all affected. The default value of 016. HERTZ is suitable for most applications.

Frequency Response	Step Response (ms) (typical)	Resolution (counts) (not including min. 10% overrange/underrange capability)
002. HERTZ/FAST	40	±50000
002. HERTZ	440	±50000
008. HERTZ	110	±25000
016. HERTZ	55	±20000
032. HERTZ	28	±10000
050. HERTZ	16	±5000
100. HERTZ	8	±5000
250. HERTZ	3	±2000
500. HERTZ	2	±2000
800. HERTZ	2	±2000

POWER-ON SOURCE Menu Item

This menu selects which value is displayed by the channel when first entering the RUN mode.

The choices are:

- "TRACK" means the live tracking value of the channel.
- "PEAK" means the highest value of the channel.
- "VALLEY" means the lowest value of the channel.
- "TRACK / PEAK" means the live tracking value and the highest value of the channel.
(Only available on Model SC3004).
- "TRACK / VALLEY" means the live tracking value and the lowest value of the channel.
(Only available on Model SC3004).
- "PEAK / VALLEY" means the highest and lowest values of the channel.
(Only available on Model SC3004).

10.5.2 DISPLAY SETUP Sub-Menu

This menu controls how data values are displayed by the channel and transmitted via serial communications.

DISPLAY. DIGITS Menu Item

Selects the number of digits displayed by the channel. The choices are:

- "5 DIGIT-BIPOLAR" displays both positive and negative numbers with five full digits (± 99999).
- "6 DIGIT-UNIPLAR" displays positive numbers with six full digits (999999) and negative numbers with five full digits (-99999).
- "7 DIGIT UNIPOLAR" displays positive number with seven full digits (9999999) and negative numbers with six digits (-999999).

This menu item may be automatically updated by a transducer's *Signature Module*.

DISPLAY. DECPY Menu Item

Selects the decimal point location on the channel's display and serial communications output. Use the [UP] and [DOWN] buttons to move the decimal point to the right and left.

This menu item may be automatically updated by a transducer's *Signature Module*.

DISPLAY. COUNT-BY Menu Item

Determines by what value the display increments or decrements. This will make the display less sensitive to a noisy signal. The choices are:

- "00001"
- "00002"
- "00005"
- "00010"
- "00020"
- "00050"
- "00100"
- "00200"

This menu item may be automatically updated by a transducer's *Signature Module*.

DISPLAY. UNITS Menu Item

Specifies the four character label that is displayed to the right of the channel's values.

This menu item doesn't change the mathematical scaling of the channel's values; that can be changed by altering the "CALIBRATION DATA -> FULL SCALE VALUE" menu item and then performing a re-calibration.

When a character position is flashing press the [UP] or [DOWN] button to change the character. Press [ENTER] to advance to the next character.

This menu item may be automatically updated by a transducer's *Signature Module*.

DISPLAY. AVERAGE Menu Item

Controls the speed with which the channel's display values will update. Display averaging does not affect the channel's analog output or its peak/valley detection, which will proceed at the speed selected by the "OPERATION -> FREQ. RESPONSE" menu item. The choices are:

- "ON" means that the display will update four times each second. The channel's values will be averaged for 1/4 second, then displayed.
- "OFF" means that the channel's display will update as quickly as possible.

10.5.3 AUX_n FUNCTION Menu Items

The AUX1 FUNCTION and AUX2 FUNCTION menu items determine what happens when the Auxiliary Function pins (labeled as “AUX1” and “AUX2”) on the channel’s connector are activated. These pins are “activated” when they are connected to the (-)Signature (labeled as “-MEM”) pin. The choices are:

- “DISABLED” means that activating the pin does nothing.
- “TRACK HOLD” means that the tracking, peak and valley values will not be updated.
- “HIGH/LOW HOLD” means that the peak and valley values will not be updated.
- “HIGH/LOW CLEAR” means that the peak and valley values are reset.
- “TARE ON” activates the channel’s Tare function (resets it to zero).
- “TARE OFF” deactivates the channel’s Tare function.

As the Auxiliary Function pins are not isolated, it is recommended that a push-button switch or relay is used to connect these pins to the (-)Signature pin.

**10.5.4 CALIBRATION TYPE
Menu Item**

This chooses the type of calibration technique to be used. There are three methods that can be used to calibrate the transducer to the Input Channel. Each has advantages and disadvantages as described in the table below.

Table 10-1: Comparison of Calibration Types

	Shunt Calibration	mV/V Calibration	2-, 3-, or 5- point Known Load Calibration
RECOMMENDED...			
...for most applications	no	yes	no
...when frequently swapping transducers	yes	yes	no
...when best possible accuracy required	no	no	yes
PROS and CONS			
Relative accuracy	good	better	best
Requires actual, calibrated loads to be applied	no	no	yes
Automatically calibrates with <i>Signature Calibration</i> transducers	yes	yes	no
Max. distance of transducer from instrument w/out sense wires	15' [5m]	50' [15m]	300' [100m]
Max. distance of transducer from instrument with sense wires	15' [5m]	100' [30m]	300' [100m]
CALIBRATION TECHNIQUE			
Zero-scale point from...	applied load	applied load	applied load
Full-scale point from...	transducer output when shunt resistor applied	internal reference	applied load
Linearity correction from...	data stored in <i>Signature Module</i> (if available)	data stored in <i>Signature Module</i> (if available)	2-point: none 3- or 5-point: applied load

It is important to know your application in order to select the appropriate calibration type. mV/V (“millivolt-per-volt”) Calibration is recommended for most applications because it doesn’t require known loads and it allows easy swapping of transducers equipped with *Signature Calibration*. When the best possible accuracy is required, Known-Load Calibration is recommended.

The choices for this menu item are:

- “TYPE= SHUNT CAL” means Shunt Calibration. First, you are prompted to apply the load entered in the “ZERO SCALE VALUE” register. Next, the instrument inserts

a known, precision resistor into the transducer circuit, which causes a predictable apparent signal. The instrument then takes a reading and adjusts itself using the "SHUNT CAL VALUE" register.

- "TYPE= MV/V CAL" means Millivolt-per-Volt Calibration. First, you are prompted to apply the load entered in the "ZERO SCALE VALUE" register. Next, the instrument takes a reading from an accurate, internal mV/V reference. The instrument then uses the "FULL SCALE MV/V" and "FULL SCALE VALUE" values in mathematical calculations to scale its tracking values.
- "TYPE= 2 POINT CAL" means 2-Point Known Load Calibration. You are prompted to apply the loads to the transducer that were entered in the "KNOWN POINT 1/2" and "KNOWN POINT 2/2" registers. This technique assumes that the transducer is linear, so the usual loads used are zero scale and full scale.
- "TYPE= 3 POINT CAL" means 3-Point Known Load Calibration. You are prompted to apply the loads to the transducer that were entered in the "KNOWN POINT 1/3" and "KNOWN POINT 2/3" and "KNOWN POINT 3/3" registers. This technique can be used to compensate for the non-linearity in the transducer. The usual loads used are zero scale, half scale and full scale, but you are not restricted to these loads.
- "TYPE= 5 POINT CAL" means 5-Point Known Load Calibration. You are prompted to apply the loads to the transducer that were entered in the "KNOWN POINT 1/5", "KNOWN POINT 2/5", "KNOWN POINT 3/5", "KNOWN POINT 4/5" and "KNOWN POINT 5/5" registers. This technique can be used to compensate for the non-linearity in the transducer. The usual loads used are zero scale, one-quarter scale, half scale, three-quarters scale and full scale, but you are not restricted to these loads.

The selection of the calibration type affects what menu items appear in the CALIBRATION DATA sub-menu.

10.5.5 CALIBRATION DATA Sub-Menu

This enters the values that will be used by the instrument when it calibrates itself to the transducer. The menu items that are displayed will change according to what the CALIBRATION TYPE is set for.

EXCITATION Menu Item

This sets the excitation voltage used to power up the transducer. The choice are:

- "EXCITATION=5VDC" means 5 volts DC excitation.
- "EXCITATION=10VDC" means 10 volts DC excitation.

This menu item may be automatically updated by a transducer's *Signature Module*.

FULL SCALE MV/V Menu Item

The transducer output when its full-scale load is applied to it, in milliVolts-per-Volt. This menu item is used by the instrument to set the gain of its amplifier circuit, and (when the CALIBRATION TYPE is set to mV/V Calibration) to calibrate the instrument. This value is normally found on the transducer's Certificate of Calibration issued by its manufacturer.

This menu item may be automatically updated by a transducer's *Signature Module*. It is available for all calibration types.

FULL SCALE VALUE Menu Item

The transducer's full-scale output in engineering units.

This menu item may be automatically updated by a transducer's *Signature Module*. It is available only with the Shunt Calibration and mV/V Calibration types.

ZERO SCALE VALUE Menu Item

The transducer's zero-scale output in engineering units, which is usually zero.

This menu item may be automatically updated by a transducer's *Signature Module*. It is available only with the Shunt Calibration and mV/V Calibration types.

SHUNT CAL VALUE Menu Item

The shunt calibration value must be calculated by using information found on the transducer's Certificate of Calibration and the following formula:

$$SHUNT\ CAL\ VALUE = \frac{Shunt-Calibration\ Output}{Full-Scale\ Output} \times Full-Scale\ Capacity$$

The terms have the following meanings:

- *Shunt-Calibration Output*: The transducer's output under shunt calibration conditions in mV/V. Sometimes called "Shunt Cal. Factor".
- *Full-Scale Output*: The transducer's full-scale output in mV/V. Sometimes called "Calibration Factor".
- *Full-Scale Capacity*: The transducer's desired full-scale reading in engineering units (PSI, lbs, Kg, etc.). You may wish to convert the engineering units of this value. For example, if the transducer full scale is 3000PSIG and you wish the channel to read in bar, you must convert 3000PSIG into 206.84 bar.

This menu item may be automatically updated by a transducer's *Signature Module*.

The shunt resistor's ohmic value used to generate the Shunt-Calibration Output is given on the transducer's Certificate of Calibration. Normally, the instrument has a shunt calibration resistor of 59000 (59K) ohms installed. If your transducer and instrument were purchased at the same time from Sensotec, the correct shunt resistor has been installed.

This menu item is only available with the Shunt Calibration type.

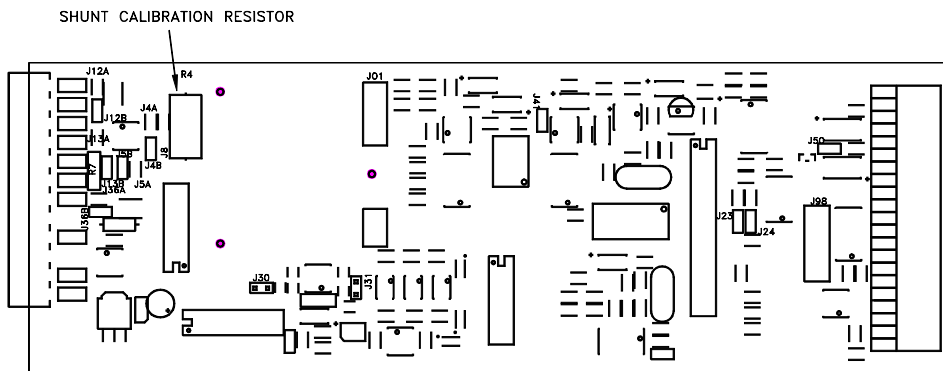

Figure 10-2: Shunt Calibration Resistor Location

To verify proper transducer operation, you can apply the shunt resistor to the transducer while the instrument is in the RUN mode. Press and hold the [ENTER] button for three seconds; this will apply the shunt resistor and display the reading.

KNOWN POINT x/y Menu Items

This enters the engineering units for the known-load calibration points. These points must match the actual loads that you will apply to the instrument during calibration. The number of calibration points depends on the CALIBRATION TYPE.

When using the 2-Point Known Load Calibration type, the following menu items are available:

- “KNOWN POINT 1/2”: point 1 of 2, usually 0% of the transducer’s full-scale capacity.
- “KNOWN POINT 2/2”: point 2 of 2, usually 100% of the transducer’s full-scale capacity.

When using the 3-Point Known Load Calibration type, the following menu items are available:

- “KNOWN POINT 1/3”: point 1 of 3, usually 0% of the transducer’s full-scale capacity.
- “KNOWN POINT 2/3”: point 2 of 3, usually 50% of the transducer’s full-scale capacity.
- “KNOWN POINT 3/3”: point 3 of 3, usually 100% of the transducer’s full-scale capacity.

When using the 5-Point Known Load Calibration type, the following menu items are available:

- “KNOWN POINT 1/5”: point 1 of 5, usually 0% of the transducer’s full-scale capacity.
- “KNOWN POINT 2/5”: point 2 of 5, usually 25% of the transducer’s full-scale capacity.
- “KNOWN POINT 3/5”: point 3 of 5, usually 50% of the transducer’s full-scale capacity.
- “KNOWN POINT 4/5”: point 4 of 5, usually 75% of the transducer’s full-scale capacity.
- “KNOWN POINT 5/5”: point 5 of 5, usually 100% of the transducer’s full-scale capacity.

To insure both correct operation of the transducer and application of the load, the instrument expects the voltage applied at each known-load point to be increasing. For example, the load applied at Known-Load Point 2/2 must cause the transducer to produce a more positive voltage than at Known-Load Point 1/2.

These menu items are only available with the Known-Load Calibration types.

10.5.6 CALIBRATE Menu Item



This menu item performs a calibration according to what was entered in the CALIBRATION TYPE and CALIBRATION DATA menu items.

Before performing a calibration, the transducer must be connected to the instrument, the CALIBRATION TYPE must be selected (see “CALIBRATION TYPE Menu Item” on page 67), and the CALIBRATION DATA must be entered (see “CALIBRATION DATA Sub-Menu” on page 69).

For maximum accuracy, allow at least twenty minutes of warm-up with the excitation voltage applied to the transducer before calibration.

If the CALIBRATION TYPE is **Shunt Calibration...**

- The display will read **DOING SHUNT CAL**, and prompt you to **APPLY 00000 UNIT** (where 00000 and UNIT are previously entered as **ZERO SCALE VALUE** and **DISPLAY UNITS**). When you have applied this load to the transducer, press [ENTER].
- The display will then read **WORKING** and calibration will take place. Upon completion, the display will indicate **DONE** and the instrument will return to the **RUN** mode.

If the CALIBRATION TYPE is **mV/V Calibration...**

- The display will read **DOING MV/V CAL**, and prompt you to **APPLY 00000 UNIT** (where 00000 and UNIT are previously entered as **ZERO SCALE VALUE** and **DISPLAY UNITS**). When you have applied this load to the transducer, press [ENTER].
- The display will then read **WORKING** and calibration will take place. Upon completion, the display will indicate **DONE** and the instrument will return to the **RUN** mode.

If the CALIBRATION TYPE is **2-Point Known Load Calibration...**

- The display will read **DOING 2POINT CAL**, and prompt you to **APPLY 00000 UNIT** (where 00000 and UNIT are previously entered as **KNOWN POINT 1/2** and **DISPLAY UNITS**). When you have applied this load to the transducer, press [ENTER].
- The display will read **WORKING**, then **APPLY 01000 UNIT** (where 01000 and UNIT are previously entered as **KNOWN POINT 2/2** and **DISPLAY UNITS**). When you have applied this load to the transducer, press [ENTER].
- Upon completion, the display will indicate **DONE** and the instrument will return to the **RUN** mode.

If the CALIBRATION TYPE is **3-Point Known Load Calibration...**

- The display will read **DOING 3POINT CAL**, and prompt you to **APPLY 00000 UNIT** (where 00000 and UNIT are previously entered as **KNOWN POINT 1/3** and **DISPLAY UNITS**). When you have applied this load to the transducer, press [ENTER].
- The display will read **WORKING**, then **APPLY 00500 UNIT** (where 00500 and UNIT are previously entered as **KNOWN POINT 2/3** and **DISPLAY UNITS**). When you have applied this load to the transducer, press [ENTER].
- The display will read **WORKING**, then **APPLY 01000 UNIT** (where 01000 and UNIT are previously entered as **KNOWN POINT 3/3** and **DISPLAY UNITS**). When you have applied this load to the transducer, press [ENTER].
- Upon completion, the display will indicate **DONE** and the instrument will return to the **RUN** mode.

If the CALIBRATION TYPE is **5-Point Known Load Calibration...**

- The display will read **DOING 5POINT CAL**, and prompt you to **APPLY 00000 UNIT** (where 00000 and UNIT are previously entered as **KNOWN POINT 1/5** and **DISPLAY. UNITS**). When you have applied this load to the transducer, press [ENTER].
- The display will read **WORKING**, then **APPLY 00250 UNIT** (where 00250 and UNIT are previously entered as **KNOWN POINT 2/5** and **DISPLAY. UNITS**). When you have applied this load to the transducer, press [ENTER].
- The display will read **WORKING**, then **APPLY 00500 UNIT** (where 00500 and UNIT are previously entered as **KNOWN POINT 3/5** and **DISPLAY. UNITS**). When you have applied this load to the transducer, press [ENTER].
- The display will read **WORKING**, then **APPLY 00750 UNIT** (where 00750 and UNIT are previously entered as **KNOWN POINT 4/5** and **DISPLAY. UNITS**). When you have applied this load to the transducer, press [ENTER].
- The display will read **WORKING**, then **APPLY 01000 UNIT** (where 01000 and UNIT are previously entered as **KNOWN POINT 5/5** and **DISPLAY. UNITS**). When you have applied this load to the transducer, press [ENTER].
- The display will now read **RETURN PNTS. =NO**. If you press [ENTER], the display will indicate **DONE** and the instrument will return to the **RUN** mode. If you use the [UP] button and [ENTER] to select **RETURN POINTS=YES**, you may now apply the same loads again but in reverse order. This will allow the instrument to measure and partially eliminate any hysteresis that may be present in the transducer. After the loads have been applied again, the display will indicate **DONE** and the instrument will return to the **RUN** mode.

10.5.7 DAC SETUP Sub-Menu

This sub-menu contains four items that control the Digital-to-Analog Converter (DAC) output of the channel.

DAC. CHANNEL Menu Item

This chooses which channel will drive the DAC output. Normally, the DAC located on a particular channel will be driven by that channel, but that need not be the case. For example, if several channels were assigned to load cells on a weighing platform, the sum of all channels could (mathematically) drive one channel's DAC output.

If the DAC is set-up to be driven by its own channel's tracking value, the Analog Output will have the frequency response specified by the channel's **FREQ. RESPONSE** menu item. Otherwise, the Analog Output will operate more slowly.

DAC. SOURCE Menu Item

This designates the data source of the channel monitored by the analog output. Each channel has three data sources: the live tracking value (TRACK), its highest value (PEAK), and its lowest value (VALLEY).

The options for this menu item are:

- "TRACK" means the live tracking value of the channel.
- "PEAK" means the highest value of the channel since the peak/valley detector was last cleared.
- "VALLEY" means the lowest value of the channel since the peak/valley detector was last cleared.

If the DAC is set-up to be driven by its own channel's tracking value, the Analog Output will have the frequency response specified by the channel's **FREQ. RESPONSE** menu item. Otherwise, the Analog Output will operate more slowly.

DAC. ZERO-SCALE Menu Item

This specifies what value, in engineering units, corresponds to zero output on the Analog Output.

"Zero output" might be 0 Volts, 2.5 Volts, 5 Volts, 4 mA or 12 mA depending on if the channel has a voltage or current output and how it is configured. See the "Digital-to-Analog Output" section of this chapter for details.

If the **UPDATE DAC SETUP** menu item is set to "ON" and the **DAC. CHANNEL** menu item is set to this channel, this menu item may be automatically updated by a transducer's *Signature Module*. If the **UPDATE DAC SETUP** menu item is "OFF", a transducer's *Signature Module* will not change this menu item.

DAC. FULL-SCALE Menu Item

Specifies what value, in engineering units, corresponds to full output on the Analog Output.

"Full output" might be 5 Volts, 10 Volts or 20 mA depending on if the channel has a voltage or current output and how it is configured. See the "Digital-to-Analog Output" section of this chapter for details.

If the **UPDATE DAC SETUP** menu item is set to "ON" and the **DAC. CHANNEL** menu item is set to this channel, this menu item may be automatically updated by a transducer's *Signature Module*. If the **UPDATE DAC SETUP** menu item is "OFF", a transducer's *Signature Module* will not change this menu item.

10.5.8 SIGNATURE MODULE Sub-Menu

UPDATE SIG. MOD? Menu Item

Updates the information stored in the transducer's *Signature Module* with any new settings that is entered into the instrument with the SETUP menus. The settings that will be updated are:

EXCITATION
FULL SCALE MV/V
FULL SCALE VALUE
SHUNT CAL VALUE
DISPLAY. UNITS

Note that changes made to the instruments display setup (such as decimal point and count-by settings) are not updated into the *Signature Module*.

Updating enters these new settings from the instrument into the *Signature Module*. If you do not update the *Signature Module*, connect a different transducer to the instrument and then re-connect the original transducer again, the instrument will revert to the settings that are stored inside the *Signature Module*.

The options for this menu item are:

- "NO" will not update the *Signature Module*.
- "YES" will display WORKING, update the *Signature Module*, then display DONE.

DEFAULT SIG. MOD? Menu Item

This menu item will overwrite any user settings in the *Signature Module* with the original default settings. The *Signature Module* always maintains a copy of the original default settings that were created at the factory.

The options for this menu item are:

- "NO" will not restore original default settings.
- "YES" will display WORKING, update the *Signature Module*, with the original factory settings, then display DONE.

UPDATE DAC SETUP Menu Item

This menu item determines whether or not the DAC. FULL SCALE and DAC. ZERO SCALE Analog Output settings are overwritten with information from a *Signature Module* when a new transducer is detected by the instrument.

The options for this menu item are:

- "YES" will allow a newly detected *Signature Module* to update the Analog Output settings.
- "NO" will not allow automatic updating of the Analog Output settings.

10.5.9 DIAGNOSTICS Sub-Menu

- DAC FULL SCALE Menu Item** When this menu item is selected, the Analog Output of the channel is forced to its full-scale output, then **DAC UPDATED** is displayed. This is useful when calibrating or trimming the readout connected to the Analog Output.
- DAC ZERO SCALE Menu Item** When this menu item is selected, the Analog Output of the channel is forced to its zero-scale output, then **DAC UPDATED** is displayed. This is useful when calibrating or trimming the readout connected to the Analog Output.
- VERSION INFO Menu Item** This menu item displays the part number and revision level of the firmware used by this channels microprocessor.
- DISPLAY ADC Menu Item** The options for this menu item are:
- “OFF” will allow the [VALUE] button to cycle through “TK” (tracking value), “HI” (peak value) and “LO” (valley value). This is the recommended option.
 - “ON” will allow the “AD” (percentage of the Analog-to-Digital converter’s full-scale digitizing capability) display source to be available along with “TK” (tracking value), “HI” (peak value) and “LO” (valley value) when the [VALUE] button is pressed on the front panel.
- The Analog-to-Digital converter counts are displayed as a percentage from -100.00% to 100.00%.
- This can be used to verify that the transducer’s output does not exceed the input range of the instrument. If the Analog-to-Digital converter readings display more than +/-10% when there is no load on the transducer, the transducer has a high zero offset.
- LINEARIZATION Menu Item** The options for this menu item are:
- “ON” will allow linearization data obtained from either the Signature Module or a 3-Point or 5-Point Known Load Calibration to affect a channel’s scaled values. This is the recommended option.
 - “OFF” will not allow linearization data to effect the channel’s scaled values. This is useful when diagnosing problems in a calibration procedure.
- DISABLE CHANNEL Menu Item** The options for this menu item are:
- “ON” will bypass the INITIALIZE and RUN modes of the channel. The track, peak and valley values of the channel are forced to 0. This option is helpful when a channel is installed but not being used. ERROR 46, which will normally occur when the (+)Sense and (-)Sense wires are not connected properly, will be suppressed.
 - “OFF” will allow normal operation of the channel.

10.6 Analog Output Configuration

10.6.1 Identifying the Output Type

A Strain-Gage Input channel is available with one of two types of digital-to-analog (DAC) outputs: voltage or current. You can determine which type of output a channel has by one of three ways:

- Consulting the instrument's Customer Information Sheet
- Examining the `SYSTEM MENU -> CONFIGURATION -> CHANNEL nn TYPE` menu item where `nn` is the number of the channel. If the channel's type is `STRAIN GAGE V`, it has a voltage output. If the channel's type is `STRAIN GAGE I`, it has a current output.
- Examining the channel's circuit board as shown in the figure below.

10.6.2 Channel Menu Items

The Analog Output can be driven by any channel's track, peak or valley value.

See the "Channel Menu" section earlier in this chapter for a complete listing of `SETUP` menu items available on the `DAC. SETUP` sub-menu.

10.6.3 Output Selection

Jumpers located on the channel's circuit board determine what outputs are generated when the value selected to drive the Analog Output (from the `DAC. CHANNEL` and `DAC. SOURCE` menu items) equals the `DAC. FULL SCALE` and `DAC. ZERO SCALE` settings.

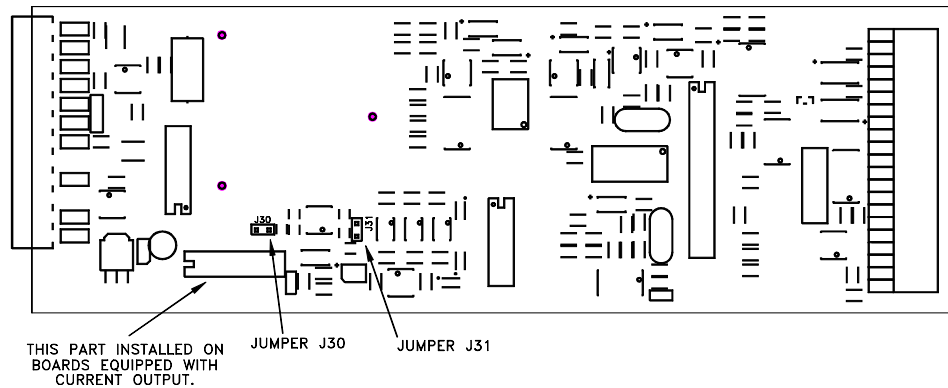

Figure 10-3: Digital-to-Analog Output Jumper Locations

	DAC. ZERO SCALE Output	DAC. FULL SCALE Output	J30 jumper	J31 jumper
CHANNELS WITH VOLTAGE OUTPUT				
0-5V	2.5 Volts	5 Volts	open	closed
±5V	0 Volts	5 Volts	open	open
0-10V	5 Volts	10 Volts	closed	closed
±10V	0 Volts	10 Volts	closed	open
CHANNELS WITH CURRENT OUTPUT				
4-20mA	4 mA	20 mA	open	open
4-20mA	12 mA	20 mA	open	closed

10.7 Troubleshooting

10.7.1 Error Messages See “Error Messages” on page 149 for information relating to error messages.

10.7.2 Common Problems and Solutions

Erratic Display Check electrical connections for continuity and the transducer’s wiring code from its Certificate of Calibration.

Make sure that the load on the transducer is constant.

Check millivolt input to the (+)Signal (“+SIG”) and (-)Signal (“-SIG”) pins with a voltmeter.

+OVLD or -OVLD on Display Indicates that the voltage across the (+)Signal (“+SIG”) and (-)Signal (“-SIG”) pins is overranging or underranging the amplifier circuit. Make certain all wires are connected properly.

If you remove all load from the transducer and you still see this message, the (+)Excitation (“+EXC”) or (-)Excitation (“-EXC”) pins may be shorted to the (+)Signal (“+SIG”) or (-)Signal (“-SIG”) pins.

If you remove all load from the transducer and you get a numeric reading, the transducer may have a high zero offset. Use the channel’s SETUP menu and set **DIAGNOSTICS -> DISPLAY ADC** to “ON”; in the RUN mode this will allow the [VALUE] button to display raw A/D readings as a percentage of its full-scale. If the raw A/D readings display more than +/-10% when there is no load on the transducer, the transducer has a high zero offset.

Analog Output Incorrect Make certain of the type of Analog Output (voltage or current) that the channel is equipped with; see “Identifying the Output Type” on page 76.

Use the **DIAGNOSTICS -> DAC FULL SCALE** and **DIAGNOSTICS -> DAC ZERO SCALE** menu items to force the Analog Output to a known output. Then, adjust your readout device, panel meter, PLC or data acquisition system to match.

Check the output selection jumpers; see “Output Selection” on page 76.

“APPLY 00000” on Power-up The channel has detected that the transducer connected to the instrument is different than the one the channel was last calibrated with. Because the **CALIBRATION TYPE** is set to either Shunt Calibration or mV/V Calibration, the instrument is prompting you to apply zero load in order to auto-calibrate to this new transducer.

Do one of the following, depending on the situation:

- Re-connect the original transducer to the channel and re-start the instrument.
- Press [ENTER] to re-calibrate the channel to this new transducer using Shunt or mV/V Calibration and accept the presently applied load as “0”. (In situations where one can’t apply “0” load to an absolute pressure transducer or a load cell with a pre-load, you can change the **CALIBRATION DATA -> ZERO-SCALE VALUE** menu item from “0” to a load that can be applied. For example, 14.7 PSIA or the known pre-load on the load cell.
- Use the **CALIBRATE** menu item to perform a Known-Load Calibration with this new transducer.

**Auxiliary Function Pins
Not Operating**

Make sure that the **AUX1 FUNCTION** or **AUX2 FUNCTION SETUP** menu items are set correctly; if they are set to **DISABLED** then they will not operate.

The Auxiliary Function (“AUX1” and “AUX2”) pins must be connected to pin 10, not pin 8, to activate them.

Sensitivity to EMI/RFI

To obtain maximum immunity to electromagnetic or radio frequency interference, make certain that the shields of the transducer cables are connected to the “cable shield connection screw” on the rear panel of the instrument. See “Unamplified Transducer Connection to Strain-Gage Input Channel” on page 60, “External Arrangement of AC powered SC1000 and SC2000” on page 27 and “External Arrangement of Model SC3004” on page 33.

Chapter 11

AC/AC-LVDT Input Channel

11.1 Features

The AC/AC-LVDT Input channel provides an AC excitation voltage to and accepts AC signals from LVDT (Linear Variable Differential Transformer) transducers. These signals are digitized, converted into engineering units, and placed into the track, peak and valley data values of the channel. Setup and calibration of the channel are made manually through the SETUP mode.

The analog-to-digital converter features adjustable digital, low-pass filtering, 12- to 18-bit resolution (depending on the filter setting) and has several different input ranges. These many input ranges allow $\pm 25,000$ count resolution (at the slowest filter setting) for a wide variety of LVDT outputs.

The AC/AC-LVDT Input channel is calibrated to the transducer by using known-displacement calibration.

Two rear panel control inputs can be field-configured for such functions as remote tare, disabling peak/valley detection and clearing the peak/valley values. A standard voltage or optional current digital-to-analog output is also provided.

To use a DC/DC LVDT with an SC instrument, use a High-Level Input channel instead of an AC/AC-LVDT Input channel.

11.2 Wiring

Connect your transducer to an AC/AC-LVDT Input channel by wiring it to the 12-pin connector of that channel. The Customer Information Sheet that shipped with the instrument describes which cards are installed in each channel. The pin-out for this connector is shown on the following table.

Table 11-1: AC/AC-LVDT Input Channel Pin Connections

Pin	Label	Function	Reference Pin
1 (top)	+EXC	(+)Excitation	10
2	N/C	No connection	
3	N/C	No connection	
4	-EXC	(-)Excitation	10
5	+SIG	(+)Signal	10
6	-SIG	(-)Signal	10
7	+OUT	Analog Output	8
8	-OUT	Analog Return	-
9	N/C	No connection	
10	DGND	Digital Ground	-
11	AUX1	Auxiliary Function 1 (connect to pin 10 to activate)	10
12 (bottom)	AUX2	Auxiliary Function 2 (connect to pin 10 to activate)	10

The Analog Output and Analog Return pins are electrically isolated from all other pins on the instrument.

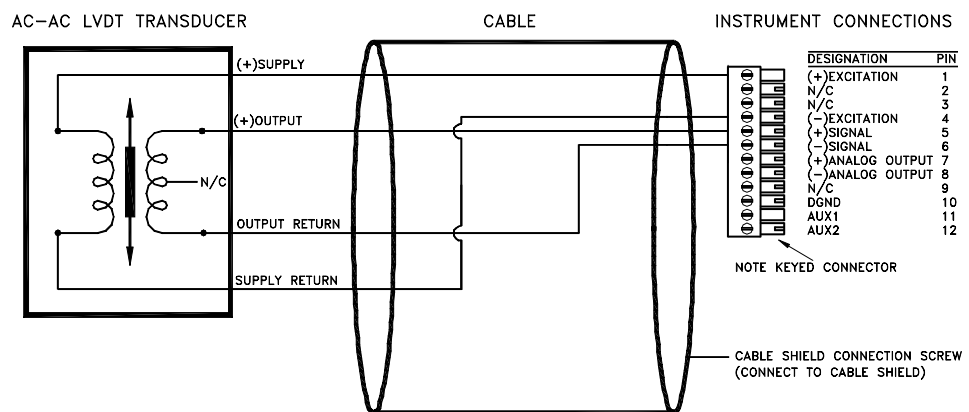

Figure 11-1: Connection of Four- or Five-wire AC/AC-LVDT

11.3 Calibration Procedure

If you are not familiar with operating the instrument in the SETUP menu mode, see “SETUP Menu mode” on page 23. A listing of all menu items is given in “Setup Menu Reference” on page 155.

Step 1: Wire the transducer to the channel’s connector.

See “Wiring” on page 80 for details.

Step 2: Enter the CALIBRATION TYPE.

You must have the capability to apply either two, three, or five known displacements to the transducer. The CALIBRATION TYPE menu item allows you to specify how many known displacements will be applied during calibration.

Step 3: Enter the CALIBRATION DATA.

Consult the Certificate of Calibration for the transducer when entering information in the CALIBRATION DATA sub-menu.

Step 4: Determine the LVDT’s electrical null point, then physically mount it.

The electrical null is the armature position that produces the least electrical output. Once this point has been determined, the transducer is physically clamped into position. See “Electrical Null and Transducer Mounting” on page 93.

Step 5: Perform the calibration.

Using the CALIBRATE menu item starts the calibration process. You will be prompted to apply displacements to the transducer as required.

11.4 Specifications

TRANSDUCER INPUT

Transducer type	full-bridge, AC/AC-LVDT
Excitation Voltage	3 VRMS @ 5kHz, short circuit protected
Transducer full-scale output	.1 to 15 VRMS @ 3 VRMS excitation
Amplifier Gain Selection	automatic
Calibration Type	2-, 3- or 5- point known displacement
A/D Converter	24-bit Sigma-Delta
Low-pass filter	digital, 24-tap FIR
Resolution	see page 83
Frequency Response	see page 83

AUXILLIARY INPUTS

Quantity	2
Type	momentary contact closure
Response Time	< 5ms
Field-Selectable Functions	tare on, tare off, peak/valley clear, peak/valley hold, track hold

ANALOG OUTPUT

Voltage range (voltage output channels)	5, ± 5 , 10 or ± 10 VDC
Current range (current output channels)	4-20 mA
Source	any channel's track, peak or valley value
Isolation	500V
Resolution	13 bits
Frequency Response	same as input if driven by the same channel's tracking data

11.5 Channel Menu

Each AC/AC-LVDT Input channel is configured and calibrated via its channel menu. Detailed instructions on operating the instrument in the SETUP Menu mode can be found in “SETUP Menu mode” on page 23. A diagram of all menus is located in “Setup Menu Reference” on page 155.

11.5.1 OPERATION Sub-Menu

This menu controls the operation of this channel when the instrument is in the RUN mode.

AUTO-ZERO Menu Item

This enables or disables the channel's automatic zeroing function. When enabled, the channel will reset its tracking value to zero when the tracking value is less than 10 display counts for a period of 10 seconds. This removes the effect of slight temperature shifts in the transducer's output.

To compensate for the transducer's initial warm-up shift, the auto-zero function operates every 2 seconds during the first 60 seconds of RUN mode operation.

The two options for this menu item are “ON” and “OFF”.

FREQ. RESPONSE Menu Item

This sets the frequency response, step response, and resolution of the channel according to the table below. The tracking value, peak/valley detector values and analog output on this channel are all affected. The default value of 016. HERTZ is suitable for most applications.

Frequency Response	Step Response (ms) (typical)	Resolution (counts) (not including minimum 10% overrange/underrange capability)
002. HERTZ/FAST	40	±25000
002. HERTZ	440	±25000
008. HERTZ	110	±15000
016. HERTZ	55	±10000
032. HERTZ	28	±10000
050. HERTZ	16	±5000
100. HERTZ	8	±5000
250. HERTZ	3	±2000
500. HERTZ	2	±2000
800. HERTZ	2	±2000

Your particular LVDT may have a lower frequency response than the AC-AC LVDT Input channel.

POWER-ON SOURCE Menu Item

This menu selects which value is displayed by the channel when first entering the RUN mode.

The choices are:

- "TRACK" means the live tracking value of the channel.
- "PEAK" means the highest value of the channel.
- "VALLEY" means the lowest value of the channel.
- "TRACK / PEAK" means the live tracking value and the highest value of the channel. (Only available on Model SC3004).
- "TRACK / VALLEY" means the live tracking value and the lowest value of the channel. (Only available on Model SC3004).
- "PEAK / VALLEY" means the highest and lowest values of the channel. (Only available on Model SC3004).

11.5.2 DISPLAY SETUP Sub-Menu

This menu controls how data values are displayed by the channel and transmitted via serial communications.

DISPLAY. DIGITS Menu Item

Selects the number of digits displayed by the channel. The choices are:

- “5 DIGIT-BIPOLAR” displays both positive and negative numbers with five full digits (± 99999).
- “6 DIGIT-UNIPLAR” displays positive numbers with six full digits (999999) and negative numbers with five full digits (-99999).
- “7 DIGIT UNIPOLAR” displays positive number with seven full digits (9999999) and negative numbers with six digits (-999999).

DISPLAY. DECPY Menu Item

Selects the decimal point location on the channel's display and serial communications output. Use the [UP] and [DOWN] buttons to move the decimal point to the right and left.

DISPLAY. COUNT-BY Menu Item

Determines by what value the display increments or decrements. This will make the display less sensitive to a noisy signal. The choices are:

- “00001”
- “00002”
- “00005”
- “00010”
- “00020”
- “00050”
- “00100”
- “00200”

DISPLAY. UNITS Menu Item

Specifies the four character label that is displayed to the right of the channel's values.

This menu item doesn't change the mathematical scaling of the channel's values; that can be changed by altering the “CALIBRATION DATA -> KNOWN POINT X/Y” menu items and then performing a re-calibration.

When a character position is flashing press the [UP] or [DOWN] button to change the character. Press [ENTER] to advance to the next character.

DISPLAY. AVERAGE Menu Item

Controls the speed with which the channel's display values will update. Display averaging does not affect the channel's analog output or its peak/valley detection, which will proceed at the speed selected by the “OPERATION -> FREQ. RESPONSE” menu item. The choices are:

- “ON” means that the display will update four times each second. The channel's values will be averaged for 1/4 second, then displayed.
- “OFF” means that the channel's display will update as quickly as possible.

11.5.3 AUXn FUNCTION Menu Items

The AUX1 FUNCTION and AUX2 FUNCTION menu items determine what happens when the Auxiliary Function pins (labeled as “AUX1” and “AUX2”) on the channel's connector are activated. These pins are “activated” when they are connected to the DGND pin. The choices are:

- “DISABLED” means that activating the pin does nothing.
- “TRACK HOLD” means that the tracking, peak and valley values will not be updated.

- "HIGH/LOW HOLD" means that the peak and valley values will not be updated.
- "HIGH/LOW CLEAR" means that the peak and valley values are reset.
- "TARE ON" activates the channel's Tare function (resets it to zero).
- "TARE OFF" deactivates the channel's Tare function.

As the Auxiliary Function pins are not isolated, it is recommended that a push-button switch or relay is used to connect these pins to the DGND pin.

11.5.4 CALIBRATION TYPE Menu Item

The choices for this menu item are:

- "TYPE= 2 POINT CAL" means 2-Point Known Displacement Calibration. You are prompted to apply the displacements to the transducer that were entered in the "KNOWN POINT 1/2" and "KNOWN POINT 2/2" registers. This technique assumes that the transducer is linear throughout the entire stroke, so the usual displacements used are zero scale and full scale.
- "TYPE= 3 POINT CAL" means 3-Point Known Displacement Calibration. You are prompted to apply the displacements to the transducer that were entered in the "KNOWN POINT 1/3" and "KNOWN POINT 2/3" and "KNOWN POINT 3/3" registers. This technique can be used to compensate for the different sensitivities that an LVDT may have on each side of its electrical null. The usual displacements used are zero scale, half scale and full scale, but you are not restricted to these displacements.
- "TYPE= 5 POINT CAL" means 5-Point Known Displacement Calibration. You are prompted to apply the displacements to the transducer that were entered in the "KNOWN POINT 1/5", "KNOWN POINT 2/5", "KNOWN POINT 3/5", "KNOWN POINT 4/5" and "KNOWN POINT 5/5" registers. This technique can be used to compensate for the non-linearity in the transducer as well as the different sensitivities on each side of its electrical null. The usual displacements used are zero scale, one-quarter scale, half scale, three-quarters scale and full scale, but you are not restricted to these displacements.

The selection of the calibration type affects what menu items appear in the CALIBRATION DATA sub-menu.

11.5.5 CALIBRATION DATA Sub-Menu

This sub-menu enters the values that will be used by the instrument when it calibrates itself to the transducer. The menu items that are displayed will change according to what the CALIBRATION TYPE is set for.

FULL SCALE VRMS Menu Item

The transducer output when its full-scale displacement is applied to it, in Volts RMS (root-mean-squared) assuming 3 VRMS excitation. This menu item is used by the instrument to set gain of its amplifier circuit. This value is normally found on the transducer's Certificate of Calibration issued by its manufacturer.

KNOWN POINT x/y Menu Items

This enters the engineering units for the known-displacement calibration points. These points must match the actual displacements that you will apply to the transducer during calibration. The number of calibration points depends on the CALIBRATION TYPE.

When using the 2-Point Known Displacement Calibration type, the following menu items are available:

- "KNOWN POINT 1/2": point 1 of 2, usually 0% of the transducer's full-scale capacity.
- "KNOWN POINT 2/2": point 2 of 2, usually 100% of the transducer's full-scale capacity.

When using the 3-Point Known Displacement Calibration type, the following menu items are available:

- "KNOWN POINT 1/3": point 1 of 3, usually 0% of the transducer's full-scale capacity.
- "KNOWN POINT 2/3": point 2 of 3, usually 50% of the transducer's full-scale capacity.
- "KNOWN POINT 3/3": point 3 of 3, usually 100% of the transducer's full-scale capacity.

When using the 5-Point Known Displacement Calibration type, the following menu items are available:

- "KNOWN POINT 1/5": point 1 of 5, usually 0% of the transducer's full-scale capacity.
- "KNOWN POINT 2/5": point 2 of 5, usually 25% of the transducer's full-scale capacity.
- "KNOWN POINT 3/5": point 3 of 5, usually 50% of the transducer's full-scale capacity.
- "KNOWN POINT 4/5": point 4 of 5, usually 75% of the transducer's full-scale capacity.
- "KNOWN POINT 5/5": point 5 of 5, usually 100% of the transducer's full-scale capacity.

To insure both correct operation of the transducer and application of the displacement, the instrument expects the voltage applied at each known-displacement point to be increasing. For example, the displacement applied at Known-Displacement Point 2/2 must cause the transducer to produce a more positive voltage than at Known-Displacement Point 1/2. You may need to swap the (+)Signal and (-)Signal wires on the 12-pin channel connector to accomplish this.

11.5.6 CALIBRATE Menu Item



This menu item performs a calibration according to what was entered in the CALIBRATION TYPE and CALIBRATION DATA menu items.

Before performing a calibration, the transducer must be connected to the instrument, the CALIBRATION TYPE must be selected (see "CALIBRATION TYPE Menu Item" on page 87) and the CALIBRATION DATA must be entered (see "CALIBRATION DATA Sub-Menu" on page 88).

For maximum accuracy, allow at least twenty minutes of warm-up with the excitation voltage applied to the transducer before calibration.

If the CALIBRATION TYPE is **2-Point Known Displacement Calibration...**

- The display will read `DOING 2POINT CAL`, and prompt you to `APPLY 00000 UNIT` (where 00000 and UNIT are previously entered as `KNOWN POINT 1/2` and `DISPLAY. UNITS`). When you have applied this displacement to the transducer, press [ENTER].
- The display will read `WORKING`, then `APPLY 01000 UNIT` (where 01000 and UNIT are previously entered as `KNOWN POINT 2/2` and `DISPLAY. UNITS`). When you have applied this displacement to the transducer, press [ENTER].
- Upon completion, the display will indicate `DONE` and the instrument will return to the RUN mode.

If the CALIBRATION TYPE is **3-Point Known Displacement Calibration...**

- The display will read `DOING 3POINT CAL`, and prompt you to `APPLY 00000 UNIT` (where 00000 and UNIT are previously entered as `KNOWN POINT 1/3` and `DISPLAY. UNITS`). When you have applied this displacement to the transducer, press [ENTER].
- The display will read `WORKING`, then `APPLY 00500 UNIT` (where 00500 and UNIT are previously entered as `KNOWN POINT 2/3` and `DISPLAY. UNITS`). When you have applied this displacement to the transducer, press [ENTER].
- The display will read `WORKING`, then `APPLY 01000 UNIT` (where 01000 and UNIT are previously entered as `KNOWN POINT 2/3` and `DISPLAY. UNITS`). When you have applied this displacement to the transducer, press [ENTER].
- Upon completion, the display will indicate `DONE` and the instrument will return to the RUN mode.

If the CALIBRATION TYPE is **5-Point Known Displacement Calibration...**

- The display will read `DOING 5POINT CAL`, and prompt you to `APPLY 00000 UNIT` (where 00000 and UNIT are previously entered as `KNOWN POINT 1/5` and `DISPLAY. UNITS`). When you have applied this displacement to the transducer, press [ENTER].
- The display will read `WORKING`, then `APPLY 00250 UNIT` (where 00250 and UNIT are previously entered as `KNOWN POINT 2/5` and `DISPLAY. UNITS`). When you have applied this displacement to the transducer, press [ENTER].
- The display will read `WORKING`, then `APPLY 00500 UNIT` (where 00500 and UNIT are previously entered as `KNOWN POINT 3/5` and `DISPLAY. UNITS`). When you have applied this displacement to the transducer, press [ENTER].
- The display will read `WORKING`, then `APPLY 00750 UNIT` (where 00750 and UNIT are

previously entered as `KNOWN POINT 4.5` and `DISPLAY. UNITS`). When you have applied this displacement to the transducer, press `[ENTER]`.

- The display will read `WORKING`, then `APPLY 01000 UNIT` (where `01000` and `UNIT` are previously entered as `KNOWN POINT 5.5` and `DISPLAY. UNITS`). When you have applied this displacement to the transducer, press `[ENTER]`.
- Upon completion, the display will indicate `DONE` and the instrument will return to the `RUN` mode.

11.5.7 DAC SETUP Sub-Menu

This sub-menu contains four items that control the Digital-to-Analog (DAC) output of the channel.

DAC. CHANNEL Menu Item

This chooses which channel will drive the DAC output. Normally, the DAC located on a particular channel will be driven by that channel, but that need not be the case. For example, if several channels were assigned to various transducers in a system, the sum of all channels could (mathematically) drive one channel's DAC output.

If the DAC is set-up to be driven by its own channel's tracking value, the Analog Output will have the frequency response specified by the channel's **FREQ. RESPONSE** menu item. Otherwise, the Analog Output will operate more slowly.

DAC. SOURCE Menu Item

This designates the data source of the channel monitored by the analog output. Each channel has three data sources: the live tracking value (TRACK), its highest value (PEAK), and its lowest value (VALLEY).

The options for this menu item are:

- "TRACK" means the live tracking value of the channel.
- "PEAK" means the highest value of the channel since the peak/valley detector was last cleared.
- "VALLEY" means the lowest value of the channel since the peak/valley detector was last cleared.

If the DAC is set-up to be driven by its own channel's tracking value, the Analog Output will have the frequency response specified by the channel's **FREQ. RESPONSE** menu item. Otherwise, the Analog Output will operate more slowly.

DAC. ZERO-SCALE Menu Item

This specifies what value, in engineering units, corresponds to zero output on the Analog Output.

"Zero output" might be 0 Volts, 2.5 Volts, 5 Volts, 4 mA or 12 mA depending on if the channel has a voltage or current output and how it is configured. See the "Digital-to-Analog Output" section of this chapter for details.

DAC. FULL-SCALE Menu Item

This specifies what value, in engineering units, corresponds to full output on the Analog Output.

"Full output" might be 5 Volts, 10 Volts or 20 mA depending on if the channel has a voltage or current output and how it is configured. See the "Digital-to-Analog Output" section of this chapter for details.

11.5.8 DIAGNOSTICS Sub-Menu

DAC FULL SCALE Menu Item	When this menu item is selected, the Analog Output of the channel is forced to its full-scale output, then DAC UPDATED is displayed. This is useful when calibrating or trimming the readout connected to the Analog Output.
DAC ZERO SCALE Menu Item	When this menu item is selected, the Analog Output of the channel is forced to its zero-scale output, then DAC UPDATED is displayed. This is useful when calibrating or trimming the readout connected to the Analog Output.
VERSION INFO Menu Item	This menu item displays the part number and revision level of the firmware used by this channels microprocessor.
DISPLAY ADC Menu Item	<p>The options for this menu item are:</p> <ul style="list-style-type: none">• “OFF” will allow the [VALUE] button to cycle through “TK” (tracking value), “HI” (peak value) and “LO” (valley value). This is the recommended option.• “ON” will allow the “AD” (percentage of the Analog-to-Digital converter’s full-scale digitizing capability) display source to be available along with “TK” (tracking value), “HI” (peak value) and “LO” (valley value) when the [VALUE] button is pressed on the front panel. <p>The Analog-to-Digital converter counts are displayed as a percentage from -100.00% to 100.00%.</p> <p>This can be used to establish the transducer’s electrical null prior to mounting. See “Electrical Null and Transducer Mounting” on page 93 for this procedure.</p>
LINEARIZATION Menu Item	<p>The options for this menu item are:</p> <ul style="list-style-type: none">• “ON” will allow linearization data obtained from a 3-Point or 5-Point Known Displacement Calibration to affect a channel’s scaled values. This is the recommended option.• “OFF” will not allow linearization data to effect the channel’s scaled values.
DISABLE CHANNEL Menu Item	<p>The options for this menu item are:</p> <ul style="list-style-type: none">• “ON” will bypass the INITIALIZE and RUN modes of the channel. The track, peak and valley values of the channel are forced to 0.• “OFF” will allow normal operation of the channel.

11.6 Electrical Null and Transducer Mounting

11.6.1 Overview The mechanical travel of an LVDT transducer is not the same as its usable measuring range. All LVDTs exhibit some non-linearity near the ends of its armature's mechanical travel. To insure that the LVDT will be used in its linear measuring range, its electrical null point must be determined. This electrical null point is the armature position which produces the minimal electrical signal output. After electrical null has been established, the LVDT is clamped down into final position in its mounting fixture.

As long as the LVDT remains clamped in this position, you do not need to re-establish the electrical null prior to every calibration.

- 11.6.2 Procedure**
- Step 1: Use the channel's SETUP menu and set **DIAGNOSTICS -> DISPLAY ADC** to "ON". Exit the SETUP menu and re-start the instrument.
 - Step 2: Display the channel to which the LVDT is connected. Press and release the [VALUE] button until the "RD" display source is shown. This is the raw analog-to-digital converter readings displayed as a percentage of its full-scale (-100% to +100%).
 - Step 3: Move the LVDT's armature to the position which displays the lowest value of raw analog-to-digital converter readings (i.e. a number close to 00.000%. This is the LVDT's electrical null.
 - Step 4: Firmly clamp down the LVDT's body.
 - Step 5: Move the LVDT's armature to roughly the position you wish to define as "positive full scale". If the displayed analog-to-digital converter reading is a negative value, you must swap the wires connected to the (+)Signal and (-)Signal pins (labeled as "+SIG" and "-SIG") on the channel's 12-pin connector to make the reading positive.

11.7 Analog Output Configuration

11.7.1 Identifying the Output Type

An AC/AC-LVDT Input channel is available with one of two types of digital-to-analog (DAC) outputs: voltage or current. You can determine which type of output a channel has by one of three ways:

- Consulting the instrument's Customer Information Sheet
- Examining the **SYSTEM MENU -> CONFIGURATION -> CHANNEL nn TYPE** menu item where nn is the number of the channel. If the channel's type is **AC-AC LVDT V**, it has a voltage output. If the channel's type is **AC-AC LVDT I**, it has a current output.
- Examining the channel's circuit board as shown in the figure below.

11.7.2 Channel Menu Items

The Analog Output can be driven by any channel's track, peak or valley value.

See the "Channel Menu" section earlier in this chapter for a complete listing of **SETUP** menu items available on the **DAC. SETUP** sub-menu.

11.7.3 Output Selection

Jumpers located on the channel's circuit board determine what outputs are generated when the value selected to drive the Analog Output (from the **DAC. CHANNEL** and **DAC. SOURCE** menu items) equals the **DAC. FULL SCALE** and **DAC. ZERO SCALE** settings.

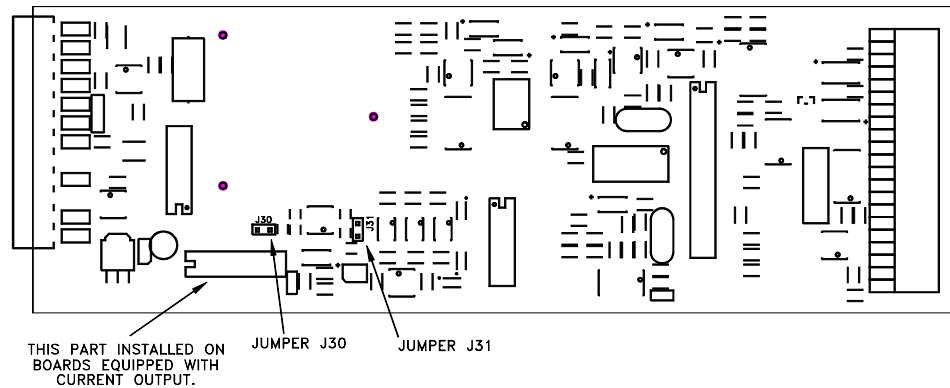

Figure 11-2: Digital-to-Analog Output Jumper Locations

	DAC. ZERO SCALE Output	DAC. FULL SCALE Output	J30 jumper	J31 jumper
CHANNELS WITH VOLTAGE OUTPUT				
0-5V	2.5 Volts	5 Volts	open	closed
±5V	0 Volts	5 Volts	open	open
0-10V	5 Volts	10 Volts	closed	closed
±10V	0 Volts	10 Volts	closed	open
CHANNELS WITH CURRENT OUTPUT				
4-20mA	4 mA	20 mA	open	open
4-20mA	12 mA	20 mA	open	closed

11.8 Troubleshooting

11.8.1 Error Messages

See “Error Messages” on page 149 for information relating to error messages.

11.8.2 Common Problems and Solutions

Erratic Display

Check electrical connections for continuity and the transducer’s wiring code from its Certificate of Calibration.

Make sure that the displacement on the transducer is constant.

Check the input to the (+)Signal (“+SIG”) and (-)Signal (“-SIG”) pins with an RMS voltmeter in its “AC Voltage” mode. Using a voltmeter in its DC Voltage mode will always display 0.

+OVLD or -OVLD on Display

Indicates that the voltage across the (+)Signal (“+SIG”) and (-)Signal (“-SIG”) pins is overranging or underranging the amplifier circuit. Make certain all wires are connected properly, the “CALIBRATION DATA -> FULL SCALE VRMS” menu item is set correctly, and that a calibration has been performed per “Calibration Procedure” on page 81.

If you move the armature back to its electrical null point and you still see this message, the (+)Excitation (“+EXC”) or (-)Excitation (“-EXC”) pins may be shorted to the (+)Signal (“+SIG”) or (-)Signal (“-SIG”) pins.

Analog Output Incorrect

Make certain of the type of Analog Output (voltage or current) that the channel is equipped with; see “Identifying the Output Type” on page 94.

Use the DIAGNOSTICS -> DAC FULL SCALE and DIAGNOSTICS -> DAC ZERO SCALE menu items to force the Analog Output to a known output. Then, adjust your readout device, panel meter, PLC or data acquisition system to match.

Check the output selection jumpers; see “Output Selection” on page 94.

Auxiliary Function Pins Not Operating

Make sure that the AUX1 FUNCTION or AUX2 FUNCTION SETUP menu items are set correctly; if they are set to DISABLED then they will not operate.

The Auxiliary Function (“AUX1” and “AUX2”) pins must be connected to pin 10, not pin 8, to activate them.

Sensitivity to EMI/RFI

To obtain maximum immunity to electromagnetic or radio frequency interference, make certain that the shields of the transducer cables are connected to the “cable shield connection screw” on the rear panel of the instrument. See “Connection of Four- or Five-wire AC/AC-LVDT” on page 80, “External Arrangement of AC powered SC1000 and SC2000” on page 27 and “External Arrangement of Model SC3004” on page 33.

Non-linearity at the end of the LVDT’s mechanical range

Most LVDTs have a usable measuring range that is smaller than their mechanical range. See “Electrical Null and Transducer Mounting” on page 93 for information on establishing the LVDT’s electrical null point to insure that the LVDT will be operated in its usable measuring range.

Chapter 12

High-Level Input Channel

12.1 Features

The High-Level Input channel provides a DC supply voltage to and accepts voltage or current signals from amplified transducers such as pressure transducers, load cells and DC-DC LVDTs. These signals are digitized, converted into engineering units, and placed into the track, peak and valley data values of the channel. Setup and calibration of the channel is made manually through the SETUP menu mode. *Signature Calibration* is not available with amplified transducers.

The analog-to-digital converter input circuit features adjustable digital, low-pass filtering, 12- to 18-bit resolution (depending on the filter setting) and has several different input ranges. These many ranges allow $\pm 50,000$ count resolution (at the slowest filter setting) across a wide variety of input ranges.

A combination of SETUP menu items and hardware jumpers are used to configure the excitation supply output voltage (+28 VDC, ± 15 VDC, +15 VDC or +12 VDC), the input type (voltage or current) and input reference (differential or single ended).

Two methods of calibrating the High-Level Input channel to the transducer are available: known-load calibration and shunt calibration. The benefits of each are discussed in "CALIBRATION TYPE Menu Item" on page 112.

Two rear panel control inputs can be field-configured for such functions as remote tare, disabling peak/valley detection and clearing the peak/valley values. A voltage or current digital-to-analog output is also provided.

12.2 Wiring

12.2.1 Channel Connector

Connect the amplified transducer, in-line amplifier or DC-DC LVDT to a High-Level Input channel by wiring it to the 12-pin connector of that channel. The Customer Information Sheet that shipped with the instrument describes which cards are installed in each channel. The pin-out for this connector is shown on the following table.

Table 12-1: High-Level Input Channel Pin Connections

Pin	Label	Function	Reference Pin
1 (top)	+EXC	(+)Excitation	10
2	SHUNT1	Shunt Cal Relay	3
3	-SHUNT2	Shunt Cal Relay	2
4	-EXC	(-)Excitation	10
5	+SIG	(+)Signal	10
6	-SIG	(-)Signal	10
7	+OUT	Analog Output	8
8	-OUT	Analog Return	-
9	N/C	No Connection	-
10	DGND	Digital Ground	-
11	AUX1	Auxiliary Function 1 (connect to pin 10 to activate)	10
12 (bottom)	AUX2	Auxiliary Function 2 (connect to pin 10 to activate)	10

The Analog Output and Analog Return pins are electrically isolated from all other pins on the instrument.

12.2.2 Bi-polar Voltage Amplifiers

Use the following wiring diagram when connecting an amplified transducer, in-line amplifier or DC-DC LVDT with a bi-polar voltage amplifier to a High-Level Input channel. Examples of such devices include

- transducers with Option 2a or Option 2b internal amplifiers (with shunt cal)
- Models UBP or UBP-10 Universal In-Line amplifiers (with shunt cal)
- Models MDL, DLA, MDLC, DW7U, DW7C and DW7S DC-DC LVDTs (no shunt cal)

See “Low Voltage DC-DC LVDTs” on page 104 for information on wiring Model DLB, DLE and DLF low-voltage DC-DC LVDTs

The High-Level Input channel's Configuration Jumpers must be set as follows for proper operation. See “Excitation and Signal Jumpers” on page 105.

- (+)Excitation supply: “+15 VDC”
- (-)Excitation supply: “-15 VDC”
- Signal type: “voltage”
- Signal reference: “single ended”

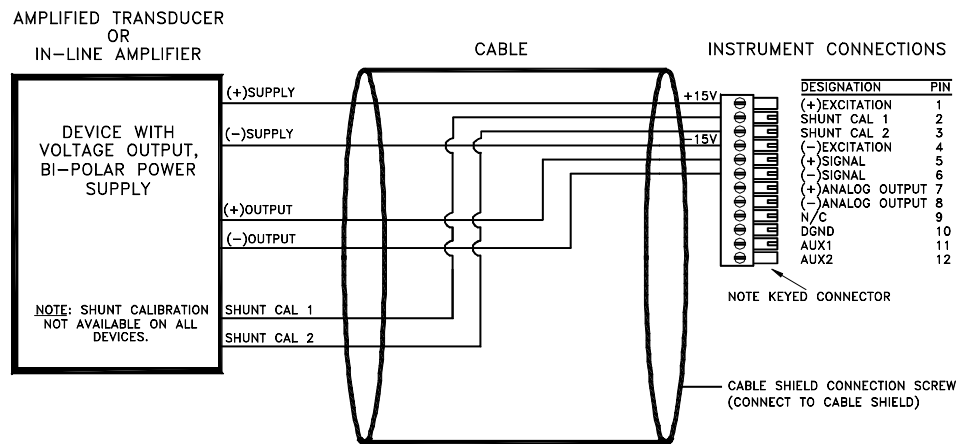

Figure 12-1: “Bi-polar Voltage Amp” Connection to High-Level Input Channel

12.2.3 Vehicle Voltage Amplifiers

Use the following wiring diagram when connecting an amplified transducer or in-line amplifier with a vehicle voltage amplifier to a High-Level Input channel. Examples of such devices include

- transducers with Option 2c or Option 2t internal amplifiers (with shunt cal)
- Models UV or UV-10 Universal In-Line amplifiers (with shunt cal)

The High-Level Input channel's Configuration Jumpers must be set as follows for proper operation. See "Excitation and Signal Jumpers" on page 105.

- (+)Excitation supply: "+28 VDC"
- (-)Excitation supply: "GND"
- Signal type: "voltage"
- Signal reference: "differential"

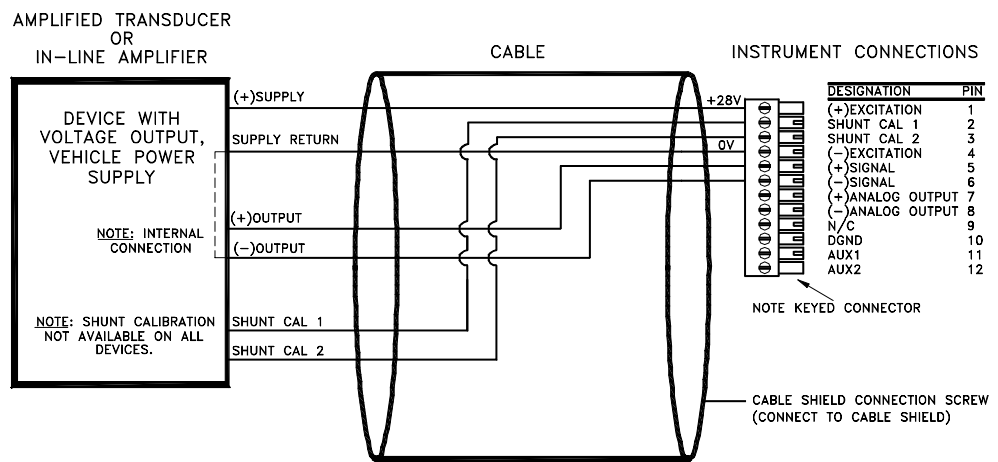

Figure 12-2: "Vehicle Voltage Amp" Connection to High-Level Input Channel

12.2.4 “3-wire Current” Amplifiers

Use the following wiring diagram when connecting an amplified transducer or in-line amplifier with a 3-wire current amplifier to a High-Level Input channel. Examples of such devices include

- transducers with the Option 2j internal amplifier (with shunt cal)
- Model U3W Universal In-Line amplifiers (with shunt cal)

The High-Level Input channel's Configuration Jumpers must be set as follows for proper operation. See “Excitation and Signal Jumpers” on page 105.

- (+)Excitation supply: “+28 VDC”
- (-)Excitation supply: “GND”
- Signal type: “current”
- Signal reference: “single ended”

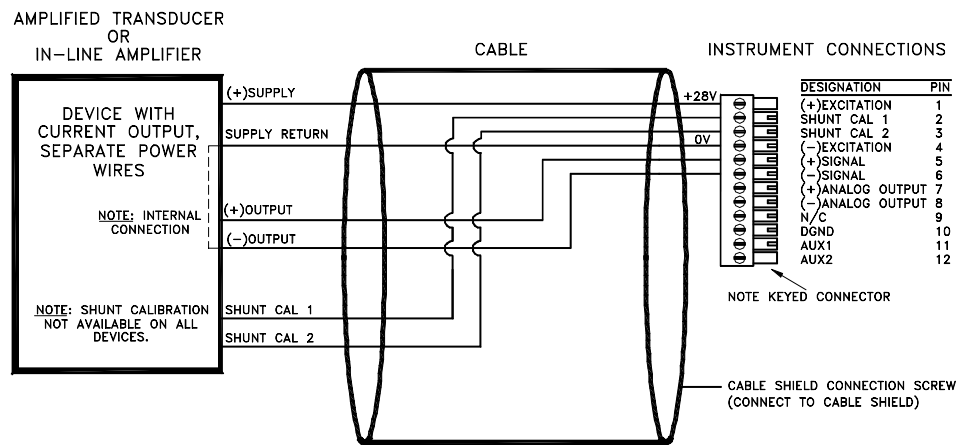

Figure 12-3: “3-wire Current Amp” Connection to High-Level Input Channel

12.2.5 “2-wire Current” Amplifiers with Buffered Shunt Cal

Use the following wiring diagram when connecting an amplified transducer or in-line amplifier with a 2-wire current amplifier to a High-Level Input channel. Examples of such devices include

- transducers with the Option 2k internal amplifier (not equipped with shunt cal)
- transducers with the Option 2k,3d internal amplifier (buffered shunt cal)
- Model U2W Universal In-Line amplifiers (not equipped with shunt cal)

The High-Level Input channel’s Configuration Jumpers must be set as follows for proper operation. See “Excitation and Signal Jumpers” on page 105.

- (+)Excitation supply: “+28 VDC”
- (-)Excitation supply: “GND”
- Signal type: “current”
- Signal reference: “single ended”

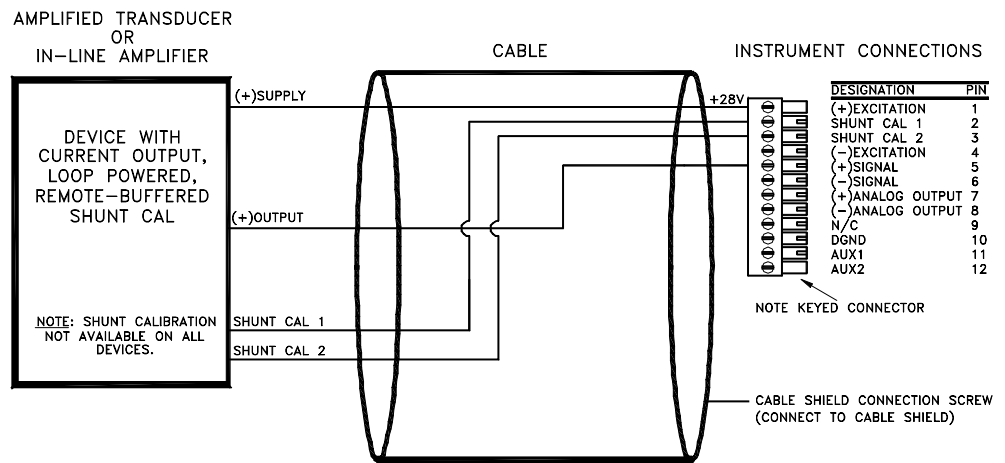

Figure 12-4: “2-wire Current Amp w/Buffered Shunt Cal” Connection to High-Level Input Channel

12.2.6 “2-wire Current” Amplifiers with Single-wire Shunt Cal

Use the following wiring diagram when connecting an amplified transducer or in-line amplifier with a 2-wire current amplifier to a High-Level Input channel. Examples of such devices include

- transducers with the Option 2p internal amplifier (not equipped with shunt cal)
- transducers with the Option 2p,3d internal amplifier (single-wire shunt cal)
- transducers with the Option 2y internal amplifier (not equipped with shunt cal)
- transducers with the Option 2y,3d internal amplifier (single-wire shunt cal)

The High-Level Input channel's Configuration Jumpers must be set as follows for proper operation. See “Excitation and Signal Jumpers” on page 105.

- (+)Excitation supply: “+28 VDC”
- (-)Excitation supply: “GND”
- Signal type: “current”
- Signal reference: “single ended”

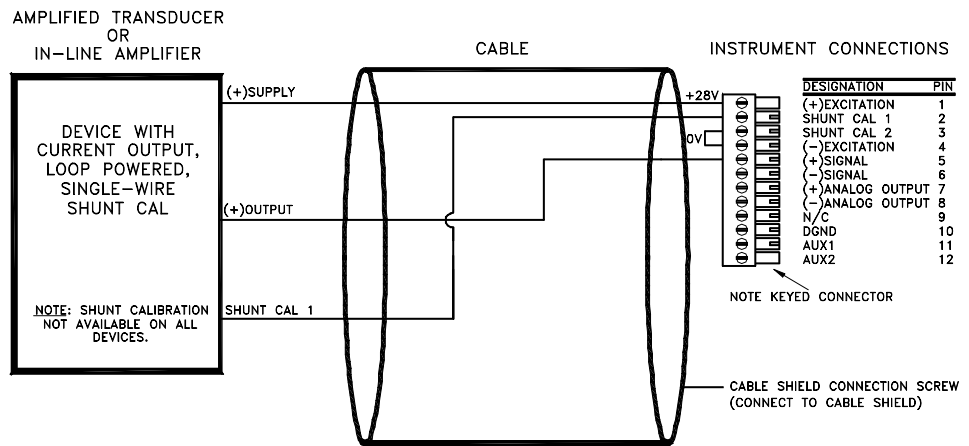

Figure 12-5: “2-wire Current Amp w/Single-Wire Shunt Cal” Connection to High-Level Input Channel

12.2.7 Low Voltage DC-DC LVDTs

Use the following wiring diagram when connecting a low-voltage DC-DC LVDT to a High-Level Input channel. Examples of such devices include

- Models DLB, DLE and DLF DC-DC LVDTs

The High-Level Input channel's Configuration Jumpers must be set as follows for proper operation. See "Excitation and Signal Jumpers" on page 105.

- (+)Excitation supply: "+12 VDC"
- (-)Excitation supply: "GND"
- Signal type: "voltage"
- Signal reference: "single ended"

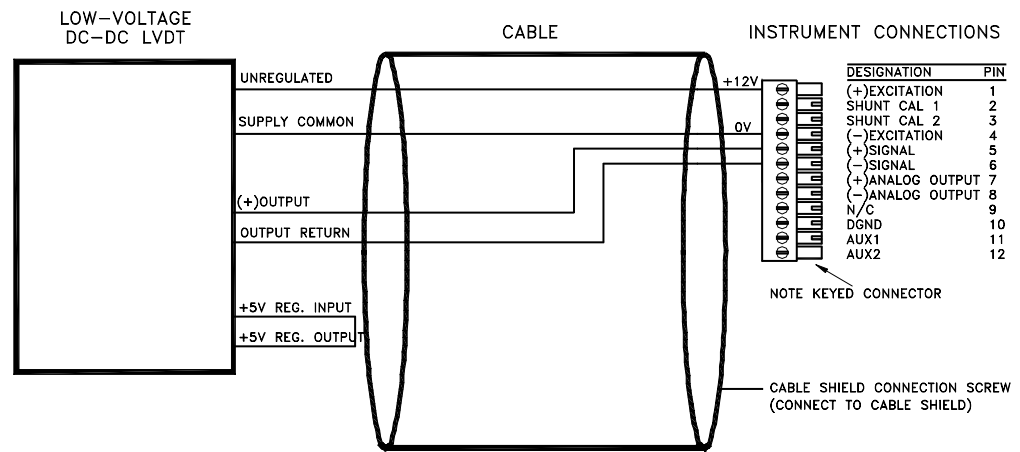

Figure 12-6: "Low Voltage" DC-DC LVDT Connection to High-Level Input Channel

12.3 Excitation and Signal Jumpers

12.3.1 Overview

The High-Level Input channel has hardware jumpers which allows configuration of excitation supply voltages and signal inputs to match the wide variety of amplified pressure, load and DC-DC LVDT transducers produced by Sensotec. "Wiring" on page 98 explains which jumpers settings are required for a particular transducer.



Make certain that you are setting the jumpers correctly. Incorrect placement of the Excitation and Signal jumpers can damage both the transducer and the instrument.

12.3.2 Setting Jumpers

Step 1: Find the "Case Removal" section in Chapter 4 "Chassis Models" on page 25 that matches the particular chassis model. Follow the directions and remove the rear panel.

Step 2: Remove the channel board from the chassis.

Step 3: Change the jumper settings according to the figure below. *Note that there are two separate jumpers for the "signal type"; both must match.*

Step 4: Re-install the channel board and replace the rear panel.

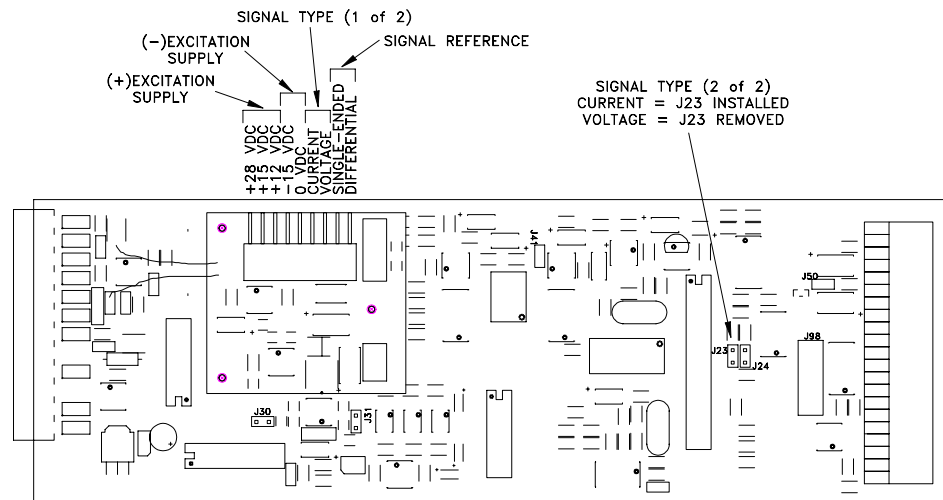

Figure 12-7: Excitation and Signal Jumper Locations on the High-Level Input Channel

12.4 Calibration Procedure

If you are not familiar with operating the instrument in the SETUP menu mode, see “SETUP Menu mode” on page 23. A listing of all menu items is given in “Setup Menu Reference” on page 155.

Step 1: Wire the transducer to the channel’s connector.

See “Wiring” on page 98 for details.

Step 2: Set the Excitation and Signal jumpers appropriate for the transducer, amplifier or DC-DC LVDT.

See “Wiring” on page 98 and “Excitation and Signal Jumpers” on page 105.

Step 3: Enter the CALIBRATION TYPE.

There are two methods that can be used to calibrate the transducer to the Input Channel. Each has advantages and disadvantages as described in the CALIBRATION TYPE menu item section. It is important to know your application in order to select the appropriate calibration type.

Step 4: Enter the CALIBRATION DATA.

Otherwise, consult the Certificate of Calibration for the transducer when entering information in the CALIBRATION DATA sub-menu.

Step 5: Perform the calibration.

Using the CALIBRATE menu item starts the calibration process. You will be prompted to apply loads to the transducer as required.

12.5 Specifications

TRANSDUCER INPUT

Transducer types	amplified with voltage or current output, (field selectable)
Excitation Voltage ⁽¹⁾	±15 VDC @ 40 mA max. +28 VDC @ 75 mA max. +12 VDC @ 40 mA max. (field selectable)
Transducer full-scale output	±1, ±5, ±10 VDC 4-20 mA (field selectable)
Calibration Type	shunt, or 2-, 3- or 5- point known load
A/D Converter	24-bit Sigma-Delta
Low-pass filter	digital, 24-tap FIR
Resolution and Frequency Response	see "FREQ. RESPONSE Menu Item" on page 108

INSTRUMENT-ONLY ACCURACY

(Sense wires used; Frequency Response setting ≤ 16Hz; Linearity, repeatability & hysteresis)

Known -Load Calibration	±0.01% F.S.
-------------------------	-------------

AUXILLIARY INPUTS

Quantity	2
Type	momentary contact closure
Response Time	< 5ms
Field-Selectable Functions	tare on, tare off, peak/valley clear, peak/valley hold, track hold

ANALOG OUTPUT

Output voltage range	5, ±5, 10 or ±10 VDC (field selectable)
Output current range (optional current output channels)	4-20 mA
Source	any channel's track, peak or valley value
Isolation	500V
Resolution	13 bits
Frequency Response	same as input when driven by the same channel's tracking data

⁽¹⁾Total excitation current of all channels must not exceed 120mA for Models SC1000, SC2000 or SC2001 and 310 mA for Model SC3004.

12.6 Channel Menu

Each High-Level Input channel is configured and calibrated via its channel menu. Detailed instructions on operating the instrument in the SETUP Menu mode can be found in "SETUP Menu mode" on page 23. A diagram of all menus is located in "Setup Menu Reference" on page 155.

12.6.1 OPERATION Sub-Menu

This menu controls the operation of this channel when the instrument is in the RUN mode.

AUTO-ZERO Menu Item

This enables or disables the channel's automatic zeroing function. The auto-zero function can remove the effect of slight temperature shifts in the transducer's output. The two options for this menu item are "ON" and "OFF".

When enabled, the channel will reset its tracking value to zero when the tracking value has never been more positive than +10 or more negative than -10 display counts for any 10 second period.

For example, assume that the DISPLAY.DECPT menu item is set to 000.00 (two decimal points). If the tracking value never leaves the range of -000.10 to +000.10 for any 10 second period, then tracking value will reset to 000.00 automatically.

To compensate for the transducer's initial warm-up shift, the auto-zero function operates every 2 seconds during the first 60 seconds of RUN mode operation.

FREQ. RESPONSE Menu Item

This sets the frequency response, step response, and resolution of the channel according to the table below. The tracking value, peak/valley detector values and analog output on this channel are all affected. The default value of 016. HERTZ is suitable for most applications.

Frequency Response	Step Response (ms) (typical)	Resolution (counts) (not including min. 10% overrange/underrange capability)	
		5V & 10V Inputs	1V & 4-20mA Inputs
002. HERTZ/FAST	40	±50000	±50000
002. HERTZ	440	±50000	±50000
008. HERTZ	110	±25000	±25000
016. HERTZ	55	±25000	±20000
032. HERTZ	28	±20000	±10000
050. HERTZ	16	±15000	±10000
100. HERTZ	8	±10000	±5000
250. HERTZ	3	±10000	±5000
500. HERTZ	2	±4000	±2500
800. HERTZ	2	±2500	±2500

POWER-ON SOURCE Menu Item

This menu selects which value is displayed by the channel when first entering the RUN mode.

The choices are:

- "TRACK" means the live tracking value of the channel.
- "PEAK" means the highest value of the channel.
- "VALLEY" means the lowest value of the channel.
- "TRACK / PEAK" means the live tracking value and the highest value of the channel.
(Only available on Model SC3004).
- "TRACK / VALLEY" means the live tracking value and the lowest value of the channel.
(Only available on Model SC3004).
- "PEAK / VALLEY" means the highest and lowest values of the channel.
(Only available on Model SC3004).

**12.6.2 DISPLAY SETUP
Sub-Menu**

This menu controls how data values are displayed by the channel and transmitted via serial communications.

**DISPLAY. DIGITS Menu
Item**

Selects the number of digits displayed by the channel. The choices are:

- "5 DIGIT-BIPOLAR" displays both positive and negative numbers with five full digits (± 99999).
- "6 DIGIT-UNIPLAAR" displays positive numbers with six full digits (999999) and negative numbers with five full digits (-99999).
- "7 DIGIT UNIPOLAR" displays positive number with seven full digits (9999999) and negative numbers with six digits (-999999).

DISPLAY. DECPY Menu Item

Selects the decimal point location on the channel's display and serial communications output. Use the [UP] and [DOWN] buttons to move the decimal point to the right and left.

This menu item may be automatically updated by a transducer's *Signature Module*.

**DISPLAY. COUNT-BY Menu
Item**

Determines by what value the display increments or decrements. This will make the display less sensitive to a noisy signal. The choices are:

- "00001"
- "00002"
- "00005"
- "00010"
- "00020"
- "00050"
- "00100"
- "00200"

DISPLAY. UNITS Menu Item

Specifies the four character label that is displayed to the right of the channel's values.

This menu item doesn't change the mathematical scaling of the channel's values; that can be changed by altering the "CALIBRATION DATA -> FULL SCALE VALUE" menu item and then performing a re-calibration.

When a character position is flashing press the [UP] or [DOWN] button to change the character. Press [ENTER] to advance to the next character.

**DISPLAY. AVERAGE Menu
Item**

Controls the speed with which the channel's display values will update. Display averaging does not affect the channel's analog output or its peak/valley detection, which will proceed at the speed selected by the "OPERATION -> FREQ. RESPONSE" menu item. The choices are:

- "ON" means that the display will update four times each second. The channel's values will be averaged for 1/4 second, then displayed.
- "OFF" means that the channel's display will update as quickly as possible.

12.6.3 AUX_n FUNCTION Menu Items

The AUX1 FUNCTION and AUX2 FUNCTION menu items determine what happens when the Auxiliary Function pins (labeled as "AUX1" and "AUX2") on the channel's connector are activated. These pins are "activated" when connected to the (-)Signature (labeled as "-MEM") pin. The choices are:

- "DISABLED" means that activating the pin does nothing.
- "TRACK HOLD" means that the tracking, peak and valley values will not be updated.
- "HIGH/LOW HOLD" means that the peak and valley values will not be updated.
- "HIGH/LOW CLEAR" means that the peak and valley values are reset.
- "TARE ON" activates the channel's Tare function (resets it to zero) .
- "TARE OFF" deactivates the channel's Tare function.

As the Auxiliary Function pins are not isolated, it is recommended that a push-button switch or relay is used to connect these pins to the Digital Ground pin.

**12.6.4 CALIBRATION
TYPE Menu Item**

This chooses the type of calibration technique to be used. There are two methods that can be used to calibrate the transducer to the Input Channel. Each has advantages and disadvantages as described in the table below.

Table 12-1: Comparison of Calibration Types

	Shunt Calibration	2-, 3-, or 5-point Known Load Calibration
RECOMMENDED...		
...for most applications	no	yes
...when frequently swapping transducers	yes	no
...when best possible accuracy required	no	yes
PROS and CONS		
Relative accuracy	good	best
Requires actual, calibrated loads to be applied	no	yes
CALIBRATION TECHNIQUE		
Zero-scale point from...	applied load	applied load
Full-scale point from...	transducer output when Shunt Cal pins connected	applied load
Linearity correction from...	N/A	2-point: none 3- or 5-point: applied load

It is important to know your application in order to select the appropriate calibration type. When the best possible accuracy is required, Known-Load Calibration is recommended. However, if known-loads are not available, Shunt Calibration may be used instead.

The choices for this menu item are:

- “TYPE= SHUNT CAL” means Shunt Calibration. First, you are prompted to apply the load entered in the “ZERO SCALE VALUE” register. Next, the instrument interconnects the Shunt Cal 1 and Shunt Cal 2 pins. This activates the transducer’s or in-line amplifier’s shunt calibration circuit which causes a predictable apparent signal. The instrument then takes a reading and adjusts itself using the “SHUNT CAL VALUE” register.
- “TYPE= 2 POINT CAL” means 2-Point Known Load Calibration. You are prompted to apply the loads to the transducer that were entered in the “KNOWN POINT 1/2” and “KNOWN POINT 2/2” registers. This technique assumes that the transducer is linear, so the usual loads used are zero scale and full scale.
- “TYPE= 3 POINT CAL” means 3-Point Known Load Calibration. You are prompted to apply the loads to the transducer that were entered in the “KNOWN POINT 1/3” and “KNOWN POINT 2/3” and “KNOWN POINT 3/3” registers. This technique can be used to

compensate for the non-linearity in the transducer. The usual loads used are zero scale, half scale and full scale, but you are not restricted to these loads.

- "TYPE= 5 POINT CAL" means 5-Point Known Load Calibration. You are prompted to apply the loads to the transducer that were entered in the "KNOWN POINT 1/5", "KNOWN POINT 2/5", "KNOWN POINT 3/5", "KNOWN POINT 4/5" and "KNOWN POINT 5/5" registers. This technique can be used to compensate for the non-linearity in the transducer. The usual loads used are zero scale, one-quarter scale, half scale, three-quarters scale and full scale, but you are not restricted to these loads.

The selection of the calibration type affects what menu items appear in the CALIBRATION DATA sub-menu.

12.6.5 CALIBRATION DATA Sub-Menu

This enters the values that will be used by the instrument when it calibrates itself to the transducer. The menu items that are displayed will change according to what the CALIBRATION TYPE is set for.

FULL SCALE VOLT or FULL SCALE CURR Menu Item

The nominal transducer/amplifier output when its full-scale load is applied to it, in volts or milliamps. This menu item is used by the instrument to set gain of its amplifier circuit. This value is normally found on the transducer's Certificate of Calibration or amplifier's Application Note.

FULL SCALE VALUE Menu Item

The transducer's full-scale output in engineering units.
It is available only with the Shunt Calibration type.

ZERO SCALE VALUE Menu Item

The transducer's zero-scale output in engineering units, which is usually zero.
It is available only with the Shunt Calibration type.

SHUNT CAL VALUE Menu Item

The shunt calibration value must be calculated by using information found on the transducer's Certificate of Calibration and the following formula:

$$SHUNT\ CAL\ VALUE = \frac{Shunt-Calibration\ Output}{Full-Scale\ Output} \times Full-Scale\ Capacity$$

The terms have the following meanings:

- *Shunt-Calibration Output*: The transducer's output when its shunt calibration function is activated in Volts or milliamps. Sometimes called "Shunt Cal. Factor".
- *Full-Scale Output*: The transducer's full-scale output in Volts or milliamps. Sometimes called "Calibration Factor".
- *Full-Scale Capacity*: The transducer's desired full-scale reading in engineering units (PSI, lbs, Kg, etc.). You may wish to convert the engineering units of this value. For example, if the transducer full scale is 3000 PSIG and you wish the channel to read in bar, you must convert 3000 PSIG into 206.84 bar. This menu item is only available with the Shunt Calibration type.

To verify proper transducer/amplifier operation, you can activate the transducer's/amplifier's shunt calibration function while the instrument is in the RUN mode. Press and hold the [ENTER] button for three seconds; this will activate the transducer's/amplifier's shunt calibration function and display the reading.

KNOWN POINT x/y Menu Items

This enters the engineering units for the known-load calibration points. These points must match the actual loads that you will apply to the instrument during calibration. The number of calibrations points depends on the CALIBRATION TYPE.

When using the 2-Point Known Load Calibration type, the following menu items are available:

- "KNOWN POINT 1/2": point 1 of 2, usually 0% of the transducer's full-scale capacity.
- "KNOWN POINT 2/2": point 2 of 2, usually 100% of the transducer's full-scale capacity.

When using the 3-Point Known Load Calibration type, the following menu items are available:

- "KNOWN POINT 1/3": point 1 of 3, usually 0% of the transducer's full-scale capacity.

- ity.
- "KNOWN POINT 2/3": point 2 of 3, usually 50% of the transducer's full-scale capacity.
- "KNOWN POINT 3/3": point 3 of 3, usually 100% of the transducer's full-scale capacity.

When using the 5-Point Known Load Calibration type, the following menu items are available:

- "KNOWN POINT 1/5": point 1 of 5, usually 0% of the transducer's full-scale capacity.
- "KNOWN POINT 2/5": point 2 of 5, usually 25% of the transducer's full-scale capacity.
- "KNOWN POINT 3/5": point 3 of 5, usually 50% of the transducer's full-scale capacity.
- "KNOWN POINT 4/5": point 4 of 5, usually 75% of the transducer's full-scale capacity.
- "KNOWN POINT 5/5": point 5 of 5, usually 100% of the transducer's full-scale capacity.

To insure both correct operation of the transducer and application of the load, the instrument expects the voltage or current applied at each known-load point to be increasing. For example, the load applied at Known-Load Point 2/2 must cause the transducer to produce a more positive voltage or current than at Known-Load Point 1/2.

These menu items are only available with the Known-Load Calibration types.

12.6.6 CALIBRATE Menu Item



This menu item performs a calibration according to what was entered in the CALIBRATION TYPE and CALIBRATION DATA menu items.

Before performing a calibration, the transducer must be connected to the instrument, the channel's Excitation and Signal Jumpers must be set, the CALIBRATION TYPE must be selected (see "CALIBRATION TYPE Menu Item" on page 112), and the CALIBRATION DATA must be entered (see "CALIBRATION DATA Sub-Menu" on page 114).

For maximum accuracy, allow at least twenty minutes of warm-up with the excitation voltage applied to the transducer before calibration.

If the CALIBRATION TYPE is **Shunt Calibration**...

- The display will read **DOING SHUNT CAL**, and prompt you to **APPLY 00000 UNIT** (where 00000 and UNIT are previously entered as **ZERO SCALE VALUE** and **DISPLAY UNITS**). When you have applied this load to the transducer, press [ENTER].
- The display will then read **WORKING** and calibration will take place. Upon completion, the display will indicate **DONE** and the instrument will return to the **RUN** mode.

If the CALIBRATION TYPE is **2-Point Known Load Calibration**...

- The display will read **DOING 2POINT CAL**, and prompt you to **APPLY 00000 UNIT** (where 00000 and UNIT are previously entered as **KNOWN POINT 1/2** and **DISPLAY UNITS**). When you have applied this load to the transducer, press [ENTER].
- The display will read **WORKING**, then **APPLY 01000 UNIT** (where 01000 and UNIT are previously entered as **KNOWN POINT 2/2** and **DISPLAY UNITS**). When you have applied this load to the transducer, press [ENTER].
- Upon completion, the display will indicate **DONE** and the instrument will return to the **RUN** mode.

If the CALIBRATION TYPE is **3-Point Known Load Calibration**...

- The display will read **DOING 3POINT CAL**, and prompt you to **APPLY 00000 UNIT** (where 00000 and UNIT are previously entered as **KNOWN POINT 1/3** and **DISPLAY UNITS**). When you have applied this load to the transducer, press [ENTER].
- The display will read **WORKING**, then **APPLY 00500 UNIT** (where 00500 and UNIT are previously entered as **KNOWN POINT 2/3** and **DISPLAY UNITS**). When you have applied this load to the transducer, press [ENTER].
- The display will read **WORKING**, then **APPLY 01000 UNIT** (where 01000 and UNIT are previously entered as **KNOWN POINT 3/3** and **DISPLAY UNITS**). When you have applied this load to the transducer, press [ENTER].
- Upon completion, the display will indicate **DONE** and the instrument will return to the **RUN** mode.

If the CALIBRATION TYPE is **5-Point Known Load Calibration**...

- The display will read **DOING 5POINT CAL**, and prompt you to **APPLY 00000 UNIT** (where 00000 and UNIT are previously entered as **KNOWN POINT 1/5** and **DISPLAY UNITS**).

- UNITS). When you have applied this load to the transducer, press [ENTER].
- The display will read **WORKING**, then **APPLY 00250 UNIT** (where 00250 and UNIT are previously entered as **KNOWN POINT 2.5** and **DISPLAY. UNITS**). When you have applied this load to the transducer, press [ENTER].
 - The display will read **WORKING**, then **APPLY 00500 UNIT** (where 00500 and UNIT are previously entered as **KNOWN POINT 3.5** and **DISPLAY. UNITS**). When you have applied this load to the transducer, press [ENTER].
 - The display will read **WORKING**, then **APPLY 00750 UNIT** (where 00750 and UNIT are previously entered as **KNOWN POINT 4.5** and **DISPLAY. UNITS**). When you have applied this load to the transducer, press [ENTER].
 - The display will read **WORKING**, then **APPLY 01000 UNIT** (where 01000 and UNIT are previously entered as **KNOWN POINT 5.5** and **DISPLAY. UNITS**). When you have applied this load to the transducer, press [ENTER].
 - The display will now read **RETURN PNTS. =NO**. If you press [ENTER], the display will indicate **DONE** and the instrument will return to the RUN mode. If you use the [UP] button and [ENTER] to select **RETURN POINTS=YES**, you may now apply the same loads again but in reverse order. This will allow the instrument to measure and partially eliminate any hysteresis that may be present in the transducer. After the loads have been applied again, the display will indicate **DONE** and the instrument will return to the RUN mode.

12.6.7 DAC SETUP Sub-Menu

This sub-menu contains four items that control the Digital-to-Analog Converter (DAC) output of the channel.

DAC. CHANNEL Menu Item

This chooses which channel will drive the DAC output. Normally, the DAC located on a particular channel will be driven by that channel, but that need not be the case. For example, if several channels were assigned to load cells on a weighing platform, the sum of all channels could (mathematically) drive one channel's DAC output.

If the DAC is set-up to be driven by its own channel's tracking value, the Analog Output will have the frequency response specified by the channel's **FREQ. RESPONSE** menu item. Otherwise, the Analog Output will operate more slowly.

DAC. SOURCE Menu Item

This designates the data source of the channel monitored by the analog output. Each channel has three data sources: the live tracking value (TRACK), its highest value (PEAK), and its lowest value (VALLEY).

The options for this menu item are:

- "TRACK" means the live tracking value of the channel.
- "PEAK" means the highest value of the channel since the peak/valley detector was last cleared.
- "VALLEY" means the lowest value of the channel since the peak/valley detector was last cleared.

If the DAC is set-up to be driven by its own channel's tracking value, the Analog Output will have the frequency response specified by the channel's **FREQ. RESPONSE** menu item. Otherwise, the Analog Output will operate more slowly.

DAC. ZERO-SCALE Menu Item

This specifies what value, in engineering units, corresponds to zero output on the Analog Output.

"Zero output" might be 0 Volts, 2.5 Volts, 5 Volts, 4 mA or 12 mA depending on if the channel has a voltage or current output and how it is configured. See the "Digital-to-Analog Output" section of this chapter for details.

DAC. FULL-SCALE Menu Item

Specifies what value, in engineering units, corresponds to full output on the Analog Output.

"Full output" might be 5 Volts, 10 Volts or 20 mA depending on if the channel has a voltage or current output and how it is configured. See the "Digital-to-Analog Output" section of this chapter for details.

12.6.8 DIAGNOSTICS Sub-Menu

- DAC FULL SCALE Menu Item** When this menu item is selected, the Analog Output of the channel is forced to its full-scale output, then **DAC UPDATED** is displayed. This is useful when calibrating or trimming the readout connected to the Analog Output.
- DAC ZERO SCALE Menu Item** When this menu item is selected, the Analog Output of the channel is forced to its zero-scale output, then **DAC UPDATED** is displayed. This is useful when calibrating or trimming the readout connected to the Analog Output.
- VERSION INFO Menu Item** This menu item displays the part number and revision level of the firmware used by this channels microprocessor.
- DISPLAY ADC Menu Item** The options for this menu item are:
- “OFF” will allow the [VALUE] button to cycle through “TK” (tracking value), “HI” (peak value) and “LO” (valley value). This is the recommended option.
 - “ON” will allow the “AD” (percentage of the Analog-to-Digital converter’s full-scale digitizing capability) display source to be available along with “TK” (tracking value), “HI” (peak value) and “LO” (valley value) when the [VALUE] button is pressed on the front panel.
- The Analog-to-Digital converter counts are displayed as a percentage from -100.00% to 100.00%.
- This can be used to verify that the transducer’s output does not exceed the input range of the instrument. If the Analog-to-Digital converter readings display more than +/-10% when there is no load on the transducer, the transducer has a high zero offset.
- LINEARIZATION Menu Item** The options for this menu item are:
- “ON” will allow linearization data obtained from either the Signature Module or a 3-Point or 5-Point Known Load Calibration to affect a channel’s scaled values. This is the recommended option.
 - “OFF” will not allow linearization data to effect the channel’s scaled values. This is useful when diagnosing problems in a calibration procedure.
- DISABLE CHANNEL Menu Item** The options for this menu item are:
- “ON” will bypass the INITIALIZE and RUN modes of the channel. The track, peak and valley values of the channel are forced to 0. This option is helpful when a channel is installed but not being used. ERROR 46, which will normally occur when the (+)Sense and (-)Sense wires are not connected properly, will be suppressed.
 - “OFF” will allow normal operation of the channel.

12.7 Analog Output Configuration

12.7.1 Identifying the Output Type

A High-Level Input channel is available with one of two types of digital-to-analog (DAC) outputs: voltage or current. You can determine which type of output a channel has by one of three ways:

- Consulting the instrument's Customer Information Sheet
- Examining the **SYSTEM MENU -> CONFIGURATION -> CHANNEL nn TYPE** menu item where nn is the number of the channel. If the channel's type is **HIGH-LEVEL V**, it has a voltage output. If the channel's type is **HIGH-LEVEL I**, it has a current output.
- Examining the channel's circuit board as shown in the figure below.

12.7.2 Channel Menu Items

The Analog Output can be driven by any channel's track, peak or valley value.

See the "Channel Menu" section earlier in this chapter for a complete listing of **SETUP** menu items available on the **DAC. SETUP** sub-menu.

12.7.3 Output Selection

Jumpers located on the channel's circuit board determine what outputs are generated when the value selected to drive the Analog Output (from the **DAC. CHANNEL** and **DAC. SOURCE** menu items) equals the **DAC. FULL SCALE** and **DAC. ZERO SCALE** settings.

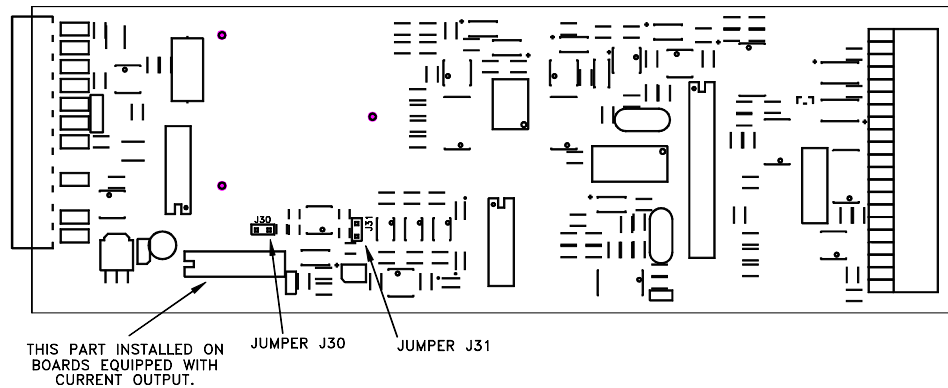

Figure 12-8: Digital-to-Analog Output Jumper Locations

	DAC. ZERO SCALE Output	DAC. FULL SCALE Output	J30 jumper	J31 jumper
CHANNELS WITH VOLTAGE OUTPUT				
0-5V	2.5 Volts	5 Volts	open	closed
±5V	0 Volts	5 Volts	open	open
0-10V	5 Volts	10 Volts	closed	closed
±10V	0 Volts	10 Volts	closed	open
CHANNELS WITH CURRENT OUTPUT				
4-20mA	4 mA	20 mA	open	open
4-20mA	12 mA	20 mA	open	closed

12.8 Troubleshooting

12.8.1 Error Messages See “Error Messages” on page 149 for information relating to error messages.

12.8.2 Common Problems and Solutions

Erratic Display Check electrical connections for continuity and the transducer’s and amplifier’s wiring code from its Certificate of Calibration and Application Note.

Make sure that the load on the transducer is constant.

Check input voltage or current to the (+)Signal (“+SIG”) and (-)Signal (“-SIG”) pins with a multi-meter.

+OVLD or -OVLD on Display Indicates that the voltage across the (+)Signal (“+SIG”) and (-)Signal (“-SIG”) pins is overranging or underranging the amplifier circuit. Make certain all wires are connected properly.

If you remove all load from the transducer and you still see this message, the (+)Excitation (“+EXC”) or (-)Excitation (“-EXC”) pins may be shorted to the (+)Signal (“+SIG”) or (-)Signal (“-SIG”) pins.

If you remove all load from the transducer and you get a numeric reading, the transducer may have a high zero offset. Use the channel’s SETUP menu and set **DIAGNOSTICS -> DISPLAY ADC** to “ON”; in the RUN mode this will allow the [VALUE] button to display raw A/D readings as a percentage of its full-scale. If the raw A/D readings display more than +/-10% when there is no load on the transducer, the transducer has a high zero offset.

Analog Output Incorrect Make certain of the type of Analog Output (voltage or current) that the channel is equipped with; see “Identifying the Output Type” on page 120.

Use the **DIAGNOSTICS -> DAC FULL SCALE** and **DIAGNOSTICS -> DAC ZERO SCALE** menu items to force the Analog Output to a known output. Then, adjust your readout device, panel meter, PLC or data acquisition system to match.

Check the output selection jumpers; see “Output Selection” on page 120.

“APPLY 00000” on Power-up The channel has detected that the transducer connected to the instrument is different than the one the channel was last calibrated with. Because the **CALIBRATION TYPE** is set to Shunt Calibration, the instrument is prompting you to apply zero load in order to calibrate to this new transducer.

Do one of the following, depending on the situation:

- Re-connect the original transducer to the channel and re-start the instrument.
- Press [ENTER] to re-calibrate the channel to this new transducer using Shunt and accept the presently applied load as “0”. (In situations where one can’t apply “0” load to an absolute pressure transducer or a load cell with a pre-load, you can change the **CALIBRATION DATA -> ZERO-SCALE VALUE** menu item from “0” to a load that can be applied. For example, 14.7 PSIA or the known pre-load on the load cell.
- Use the **CALIBRATE** menu item to perform a Known-Load Calibration with this new transducer.

**Auxiliary Function Pins
Not Operating**

Make sure that the **AUX1 FUNCTION** or **AUX2 FUNCTION SETUP** menu items are set correctly; if they are set to **DISABLED** then they will not operate.

The Auxiliary Function (“AUX1” and “AUX2”) pins must be connected to pin 10, not pin 8, to activate them.

Sensitivity to EMI/RFI

To obtain maximum immunity to electromagnetic or radio frequency interference, make certain that the shields of the transducer cables are connected to the “cable shield connection screw” on the rear panel of the instrument. See “Wiring” on page 98, “External Arrangement of AC powered SC1000 and SC2000” on page 27 and “External Arrangement of Model SC3004” on page 33.

Chapter 13

Relay Output Channel

13.1 Features

13.1.1 First Channel Installed

The first Relay Output channel installed in an instrument supplements the standard four limits (Limit 1, Limit 2, Limit 3 and Limit 4) . Its four, dry contact relay outputs will mirror the Limit Outputs pins of the System connector.

In the **SYSTEM -> CONFIGURATION** sub-menu, channels of this type are identified as **LIMIT 01-04**.

13.1.2 Second Channel Installed

The second Relay Output channel installed in an instrument adds another four limits to the instrument (Limit 5, Limit 6, Limit 7 and Limit 8). Its relay outputs show the status of these limits.

In the **SYSTEM -> CONFIGURATION** sub-menu, channels of this type are identified as **LIMIT 05-08**.

13.1.3 Third Channel Installed

The third Relay Output channel installed in an instrument adds another four limits to the instrument (Limit 9, Limit 10, Limit 11 and Limit 12). Its relay outputs show the status of these limits.

In the **SYSTEM -> CONFIGURATION** sub-menu, channels of this type are identified as **LIMIT 09-12**.

13.1.4 Fourth Channel Installed

The fourth Relay Output channel installed in an instrument adds another four limits to the instrument (Limit 13, Limit 14, Limit 15 and Limit 16). Its relay outputs show the status of these limits.

In the **SYSTEM -> CONFIGURATION** sub-menu, channels of this type are identified as **LIMIT 13-16**.

13.2 Wiring

The pin-out for the Relay Output channel's 12-pin connector is shown in the following table.

Table 13-1: Relay Output Channel Pin Connections

Pin	Label	Function	Reference Pin
1 (top)	RELAY1 NC	Relay 1 normally closed	2
2	RELAY1 C	Relay 1 common	-
3	RELAY1 NO	Relay 1 normally open	2
4	RELAY2 NC	Relay 2 normally closed	5
5	RELAY2 C	Relay 2 common	-
6	RELAY2 NO	Relay 2 normally open	5
7	RELAY3 NC	Relay 3 normally closed	8
8	RELAY3 C	Relay 3 common	-
9	RELAY3 NO	Relay 3 normally open	8
10	RELAY4 NC	Relay 4 normally closed	11
11	RELAY4 C	Relay 4 common	-
12 (bottom)	RELAY4 NO	Relay 4 normally open	11

13.3 Setup Procedure

If you are not familiar with operating the instrument in the SETUP menu mode, see “SETUP Menu mode” on page 23. A listing of all menu item is given in “Setup Menu Reference” on page 155.

Step 1: Wire to the channel’s connector.

See the “Wiring” section earlier in this chapter for details.

Step 2: Use the appropriate Limit Menu to setup the limits.

See “Limits” on page 53 for information about limits.

A SensoCode program running on a Mathematics Virtual Channel may override the default behavior of the relay outputs. Consult the Customer Information Sheet included with your instrument for details.

13.4 Specifications

RELAY OUTPUT

Quantity and Type	4 form C
Contact Rating	0.5A @ 50VAC max. (consult factory for 125VAC max. operation) 1A @ 30VDC max.

13.5 Channel Menu

The Relay Output channel's SETUP menu allows you to manually turn the relays on and off to verify that they are functioning. To change the operation of the limits, see "Limit Menus" on page 55.

Detailed instructions on operating the instrument in the SETUP Menu mode can be found in "SETUP Menu mode" on page 23. A diagram of all menus is located in "Setup Menu Reference" on page 155.

13.5.1 DIAGNOSTICS Sub-Menu

- | | |
|--------------------------|---|
| RELAY 1 Menu Item | The options for this menu item are: <ul style="list-style-type: none">• "ON" will turn the relay on.• "OFF" will turn the relay off. |
| RELAY 2 Menu Item | The options for this menu item are: <ul style="list-style-type: none">• "ON" will turn the relay on.• "OFF" will turn the relay off. |
| RELAY 3 Menu Item | The options for this menu item are: <ul style="list-style-type: none">• "ON" will turn the relay on.• "OFF" will turn the relay off. |
| RELAY 4 Menu Item | The options for this menu item are: <ul style="list-style-type: none">• "ON" will turn the relay on.• "OFF" will turn the relay off. |

Chapter 14

DAC Output Channel

14.1 Features

The DAC Output channel uses a digital-to-analog converter to generate a voltage or current from any channel's track, peak or valley value. This type of channel is often used to provide a Mathematics Virtual channel with an analog output.

14.2 Wiring

Connect your readout instrument to a DAC Output channel by wiring it to the 12-pin connector of that channel. The Customer Information Sheet that shipped with the instrument describes which cards are installed in each channel. The pin-out for this connector is shown on the following table.

Table 14-1: DAC Output Channel Pin Connections

Pin	Label	Function	Reference Pin
1 (top)	N/C	No connection	
2	N/C	No connection	
3	N/C	No connection	
4	N/C	No connection	
5	N/C	No connection	
6	N/C	No connection	
7	+OUT	Analog Output	8
8	-OUT	Analog Return	-
9	N/C	No connection	
10	N/C	No connection	
11	N/C	No connection	
12 (bottom)	N/C	No connection	

The Analog Output and Analog Return pins are electrically isolated from all other pins on the instrument.

14.3 Setup Procedure

If you are not familiar with operating the instrument in the SETUP menu mode, see “SETUP Menu mode” on page 23. A listing of all menu items is given in “Setup Menu Reference” on page 155.

Step 1: Determine if you have a Voltage DAC Output channel or a Current DAC Output channel.

Check the instrument’s Customer Information Sheet, or see “Identifying the Output Type” on page 135.

Step 2: Wire the readout instrument to the channel’s connector.

See the “Wiring” section earlier in this chapter for details.

Step 3: Select the value (channel and source) used to drive the Analog Output

See the “Channel Menu” on page 133 for details.

Step 4: Select the full-scale and zero-scale settings used to drive the Analog Output.

See the “Channel Menu” on page 133 for details.

14.4 Specifications

ANALOG OUTPUT

Voltage range (voltage output channels)	5, ± 5 or 10 VDC
Current range (current output channels)	4-20 mA
Source	any channel's track, peak or valley value
Isolation	500V
Resolution	12 bits
Update Rate	depends on how many channels are installed in the instrument

14.5 Channel Menu

Each DAC Output channel is configured and calibrated via its channel menu. Detailed instructions on operating the instrument in the SETUP Menu mode can be found in “SETUP Menu mode” on page 23. A diagram of all menus is located in “Setup Menu Reference” on page 155.

14.5.1 DAC SETUP Sub-Menu

This sub-menu contains four items that controls the analog output of the channel.

DAC. CHANNEL Menu Item

This chooses which channel will drive the Digital-to-Analog Converter (DAC) output.

DAC. SOURCE Menu Item

This designates the data source of the channel monitored by the analog output. Each channel has three data sources: the live tracking value (TRACK), its highest value (PEAK), and its lowest value (VALLEY).

The options for this menu item are:

- “TRACK” means the live tracking value of the channel.
- “PEAK” means the highest value of the channel since the peak/valley detector was last cleared.
- “VALLEY” means the lowest value of the channel since the peak/valley detector was last cleared.

DAC. ZERO-SCALE Menu Item

This specifies what value, in engineering units, corresponds to zero output on the Analog Output.

“Zero output” might be 0 Volts, 2.5 Volts, 5 Volts, 4 mA or 12 mA depending on if the channel has a voltage or current output and how it is configured. See the “Digital-to-Analog Output” section of this chapter for details.

This menu item is **not** automatically updated by another channel’s *Signature Module* equipped transducer.

DAC. FULL-SCALE Menu Item

This specifies what value, in engineering units, corresponds to full output on the Analog Output.

“Full output” might be 5 Volts, 10 Volts or 20 mA depending on if the channel has a voltage or current output and how it is configured. See the “Digital-to-Analog Output” section of this chapter for details.

This menu item is **not** automatically updated by another channel’s *Signature Module* equipped transducer.

14.5.2 DIAGNOSTICS Sub-Menu

- DAC FULL SCALE Menu Item** When this menu item is selected, the Analog Output of the channel is forced to its full-scale output, then **DAC UPDATED** is displayed. This is useful when calibrating or trimming the readout connected to the Analog Output.
- DAC ZERO SCALE Menu Item** When this menu item is selected, the Analog Output of the channel is forced to its zero-scale output, then **DAC UPDATED** is displayed. This is useful when calibrating or trimming the readout connected to the Analog Output.

14.6 Analog Output Configuration

14.6.1 Identifying the Output Type

A DAC Output channel is available with one of two types of digital-to-analog (DAC) outputs: voltage or current. You can determine which type of output a channel has by one of three ways:

- Consulting the instrument's Customer Information Sheet
- Examining the **SYSTEM MENU -> CONFIGURATION -> CHANNEL nn TYPE** menu item where nn is the number of the channel. If the channel's type is **VOLTAGE DAC**, it has a voltage output. If the channel's type is **CURRENT DAC**, it has a current output.
- Examining the channel's circuit board as shown in the figure below.

14.6.2 Channel Menu Items

The Analog Output can be driven by any channel's track, peak or valley value.

See the "Channel Menu" section earlier in this chapter for a complete listing of **SETUP** menu items available on the **DAC. SETUP** sub-menu.

14.6.3 Output Selection

Jumpers located on the channel's circuit board determine what outputs are generated when the value selected to drive the Analog Output (from the **DAC. CHANNEL** and **DAC. SOURCE** menu items) equals the **DAC. FULL SCALE** and **DAC. ZERO SCALE** settings.

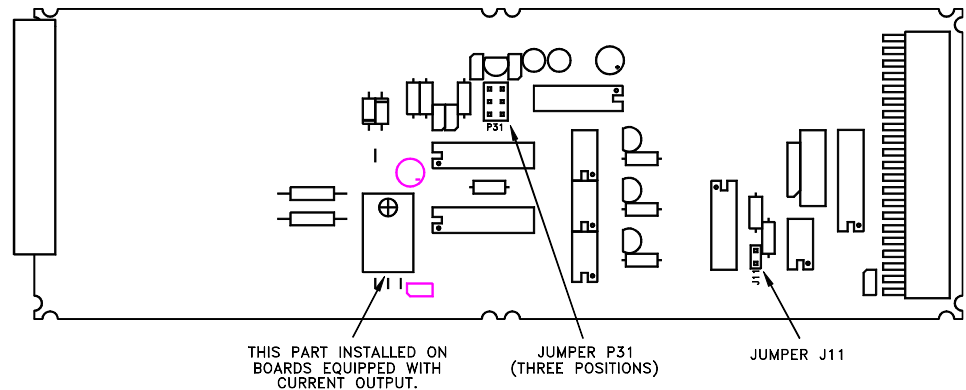

Figure 14-1: Digital-to-Analog Output Jumper Locations

	DAC. ZERO SCALE Output	DAC. FULL SCALE Output	P31 jumper	J11 jumper
CHANNELS WITH VOLTAGE OUTPUT				
0-5V	2.5 Volts	5 Volts	bottom	open
0-5V	0 Volts	5 Volts	bottom	closed
±5V	0 Volts	5 Volts	top	open
0-10V	5 Volts	10 Volts	middle	open
0-10V	0 Volts	10 Volts	middle	closed
CHANNELS WITH CURRENT OUTPUT				
4-20mA	4 mA	20 mA	bottom	closed
4-20mA	12 mA	20 mA	bottom	open

14.7 Troubleshooting

14.7.1 Error Messages

See “Error Messages” on page 149 for information relating to error messages.

14.7.2 Common Problems and Solutions

Analog Output Incorrect

Make certain of the type of Analog Output (voltage or current) that the channel is equipped with; see “Identifying the Output Type” on page 135.

Use the `DIAGNOSTICS -> DAC FULL SCALE` and `DIAGNOSTICS -> DAC ZERO SCALE` menu items to force the Analog Output to a known output. Then, adjust your readout device, panel meter, PLC or data acquisition system to match.

Check the output selection jumpers; see “Output Selection” on page 135.

Check the “`DAC SETUP -> DAC. ZERO-SCALE`” and “`DAC SETUP -> DAC FULL-SCALE`” menu items.

Sensitivity to EMI/RFI

To obtain maximum immunity to electromagnetic or radio frequency interference, make certain that the shield of the cable is connected to ground/earth only at the read-out device. The shield of the cable should not be connected to the instrument.

Chapter 15

Split Display Virtual Channel

15.1 Features

The Split Display Virtual Channel allows the display of two track, peak or valley values from any two channels at the same time. One value is displayed on the left side of the display, and another value is displayed on the right side.

The display setup used to format each value is inherited from the source channel of the value.

Split Displays are most useful on chassis with a 16-character display such as the Models SC1000, SC2000 and SC2001. The quad-line, 20-character display of the Model SC3004, however, already allows an Input Channel to show its own Track & Peak, Track & Valley or Peak & Valley values on the display at the same time. Thus, a Split Display Virtual Channel is not generally used on an Model SC3004.

15.2 Wiring

A Virtual Channel exists in software only; it does not occupy a physical slot inside of the instrument's chassis. However, a Virtual Channel does require a channel number.

There is no rear-panel connector for a Virtual Channel.

15.3 Setup Procedure

If you are not familiar with operating the instrument in the SETUP menu mode, see "SETUP Menu mode" on page 23. A listing of all menu item is given in "Setup Menu Reference" on page 155.

Step 1: Enter the value to be displayed on the left side with `LEFT CHANNEL` and `LEFT SOURCE`.

Step 2: Enter the value to be displayed on the right side with `RIGHT CHANNEL` and `RIGHT SOURCE`.

15.4 Channel Menu

Detailed instructions on operating the instrument in the SETUP Menu mode can be found in "SETUP Menu mode" on page 23. A diagram of all menus is located in "Setup Menu Reference" on page 155.

- LEFT CHANNEL Menu Item** This specifies the channel that is displayed on the left half of the split display.
- LEFT SOURCE Menu Item** This lets you designate the data source of the channel monitored by the left half of the split display. Each channel has three data sources: the live tracking value (TRACK), its highest value (PEAK), and its lowest value (VALLEY).
- The options for this menu item are:
- "TRACK" means the live tracking value of the channel.
 - "PEAK" means the highest value of the channel since the peak detector was last cleared.
 - "VALLEY" means the lowest value of the channel since the valley detector was last cleared.
- RIGHT CHANNEL Menu Item** This specifies the channel that is displayed on the right half of the split display.
- RIGHT SOURCE Menu Item** This lets you designate the data source of the channel monitored by the right half of the split display. Each channel has three data sources: the live tracking value (TRACK), its highest value (PEAK), and its lowest value (VALLEY).
- The options for this menu item are:
- "TRACK" means the live tracking value of the channel.
 - "PEAK" means the highest value of the channel since the peak detector was last cleared.
 - "VALLEY" means the lowest value of the channel since the valley detector was last cleared.
- LEAVE MENU Menu Item** When the menu item is displayed, press [ENTER] to leave this menu. Press [EXIT] to return to the RUN mode.

Chapter 16

Mathematics Virtual Channel

16.1 Features

The Mathematics Virtual Channel is a powerful, flexible means to allow SC Series Instruments to perform simple to moderate functions that previously required the use of expensive programmable logic controllers (PLC).

A Mathematics Virtual Channel is akin to a PLC; it can execute programs written in an interpretive language called SensoCode. At the time of order, your specific application is analyzed by our sales and engineering staff and one or more SensoCode programs are created. These SensoCode programs are loaded into the Mathematics Virtual channels of the instrument at the factory. The end result is an instrument that meets your specific needs but is built with proven hardware and software.

SensoCode programs allow the instrument to perform a variety of functions including:

- **Mathematics:** addition, subtraction, multiplication, division, square roots, etc.
- **Logical:** if/then condition statements, comparison of values
- **Timing**
- **Input:** from any channel's track, peak or valley values, open-collector inputs, constant user-entered values from the SETUP menu
- **Output:** Each Mathematics Channel generates its own track, peak, and valley values. A SensoCode program can "take control" of the Limit Output and/or front panel indicator lights.

16.2 Wiring

A Virtual Channel exists in software only; it does not occupy a physical slot inside of the instrument's chassis. However, a Virtual Channel does require a channel number.

A SensoCode program that is executed by a Mathematics Virtual Channel can use the System connector's Limit Output pins and Function Input pins for its own purposes. Consult the Customer Information Sheet included with the particular instrument for details.

16.3 Setup Procedure

If you are not familiar with operating the instrument in the SETUP menu mode, see “SETUP Menu mode” on page 23. A listing of all menu item is given in “Setup Menu Reference” on page 155.

Step 1: Examine the Customer Information Sheet.

The instrument’s Customer information Sheet contains important information about what each Mathematics Channel does and what Function Inputs and/or Limit Output pins of the System connector are used.

Step 2: Wire to the pins on the System connector.

See “System Connector” on page 35. It is important to read the Customer Information Sheet to determine the wiring for your application.

Step 3: Verify operation.

16.4 Channel Menu

Each Mathematics Virtual Channel can have its configuration and SensoCode programming examined via its channel menu. It is not possible to alter the SensoCode program with the SETUP menu. Detailed instructions on operating the instrument in the SETUP Menu mode can be found in "SETUP Menu mode" on page 23. A diagram of all menus is located in "Setup Menu Reference" on page 155.

16.4.1 SENSOCODE P/N Menu Item

This menu item displays the part number and revision level of the SensoCode program loaded in this Mathematics Virtual Channel.

16.4.2 USER VALUES Sub-Menu

This sub-menu contains menu items for each of the User Values. User Values are constant numeric values that can be edited by the user and read by a SensoCode program. The use of each User Value depends on the SensoCode program loaded in the Mathematics Virtual Channel.

By default, the four items on this menu are USER VALUE 1, USER VALUE 2, USER VALUE 3 and USER VALUE 4. However, a SensoCode program can alter the menu item text for each of the User Values to make them more relevant to the operator. For example, USER VALUE 1 might be re-titled JELLY BEAN COUNT.

16.4.3 VIEW SENSOCODE Menu Item

This menu item allows the display of each "step" (either an operand or an instruction) of the SensoCode program presently loaded into a Mathematics Virtual Channel. Pressing [ENTER] will display the next step of the SensoCode program until the entire program has been viewed.

SensoCode programs cannot be altered with the SETUP Mode menu; they can only be loaded via the serial port with the Instrument Utility Software.

16.4.4 VIEW COMMANDS Sub-Menu

This sub-menu contains menu items for each of the Command Strings that can be used by a SensoCode program. Command Strings are text constants that can be read by a SensoCode program. They are not able to be changed with the SETUP menu. The use of each Command String depends on the SensoCode program loaded in the Mathematics Virtual Channel.

The items on this menu are COMMAND 0, COMMAND 1, COMMAND 2, COMMAND 3, COMMAND 4, COMMAND 5, COMMAND 6, and COMMAND 7.

16.4.5 DISPLAY SETUP Sub-Menu

This menu controls how data values are displayed by the channel and transmitted via serial communications.

DISPLAY. DIGITS Menu Item

Selects the number of digits displayed by the channel. The choices are:

- "5 DIGIT-BIPOLAR" displays both positive and negative numbers with five full digits (± 99999).
- "6 DIGIT-UNIPOAR" displays positive numbers with six full digits (999999) and negative numbers with five full digits (-99999).
- "7 DIGIT UNIPOLAR" displays positive number with seven full digits (9999999) and negative numbers with six digits (-999999).

DISPLAY. DECPY Menu Item

Selects the decimal point location on the channel's display and serial communications output. Use the [UP] and [DOWN] buttons to move the decimal point to the right and left.

DISPLAY. COUNT-BY Menu Item

Determines by what value the display increments or decrements. This will make the display less sensitive to a noisy signal. The choices are:

- "00001"
- "00002"
- "00005"
- "00010"
- "00020"
- "00050"
- "00100"
- "00200"

DISPLAY. UNITS Menu Item

Specifies the four character label that is displayed to the right of the channel's values. This menu item doesn't change the mathematical scaling of the channel's values; that is determined by the "CALIBRATION DATA -> FULL SCALE VALUE" menu item.

When a character position is flashing press the [UP] or [DOWN] button to change the character. Press [ENTER] to advance to the next character.

DISPLAY. AVERAGE Menu Item

Controls the speed with which the channel's display values will update. The choices are:

- "ON" means that the display will update four times each second. The channel's values will be averaged for 1/4 second, then displayed.
- "OFF" means that the channel's display will update as quickly as possible.

16.4.6 POWER-ON SOURCE Menu Item

This menu selects which value is displayed by the channel when first entering the RUN mode.

For single-line displays, the choices are:

- "TRACK" means the live tracking value of the channel.
- "PEAK" means the highest value of the channel.
- "VALLEY" means the lowest value of the channel.

For multi-line displays, the choices are:

- "TRACK" means the live tracking value of the channel.
- "PEAK" means the highest value of the channel.
- "VALLEY" means the lowest value of the channel.
- "TRACK / PEAK" means the live tracking value and the highest value of the channel.
- "TRACK / VALLEY" means the live tracking value and the lowest value of the channel.
- "PEAK / VALLEY" means the highest and lowest values of the channel.

16.5 Troubleshooting

See “Error Messages” on page 149 for information relating to error messages.

The instrument’s Customer information Sheet contains important information about what indicator lights and which Function Input pins and/or Limit Output pins of the System connector are used.

Chapter 17

Error Messages

17.1 Overview

If the instrument detects an error during the RUN, INITIALIZE, or SETUP modes, it stops operation and enters its ERROR mode as described in “Operating Modes” on page 19.

The most frequent causes of error messages are:

- Wiring/electrical connection problems
- Misplaced address jumpers when installing or removing channel circuit boards
- Swapping channel circuit boards between instruments

17.2 Error Message List

- Error 05, DIVIDE BY ZERO** A Mathematics Virtual channel has attempted to divide by zero.
- Error 07, SQUARE ROOT** A Mathematics Virtual channel has attempted to take the square root of a negative number.
- Error 09, LOG/LN** A Mathematics Virtual channel has attempted to take the logarithm of either zero or a negative number.
- Error 20, CHANNEL >MAXCH** An invalid channel number has been encountered by the instrument. Restart the instrument. If this error persists, contact Sensotec with the information found in the SYSTEM MENU -> SOFTWARE REV. menu item.
- Error 21, BLOWN STACK** The instrument's software stack has overflowed. Restart the instrument. If this error persists, contact Sensotec with the information found in the SYSTEM MENU -> SOFTWARE REV. menu item.
- Error 22, TYPE NOT FOUND** The instrument has not been programmed to understand the type of channel. Contact Sensotec with the information found in the SYSTEM MENU -> SOFTWARE REV. menu item.
- Error 23, CAN'T RENDER FS** The full-scale value of the transducer cannot be rendered on the display with the selected DISPLAY SETUP menu settings. Change the DISPLAY SETUP menu settings to better match the transducer's capacity.
- Error 24, SIG. MOD CRC ROM** A checksum error occurred while reading a *Signature Module's* read-only-memory. Check the wiring and restart the instrument. This error may occur with very long cable lengths.
- Error 25, SIG. MOD CRC READ** A checksum failure occurred reading data from a Signature Module. Check the wiring. This error may be caused by a faulty *Signature Module*.
- Error 26, NO SIG. MOD.** No *Signature Module* was detected during UPDATE SIG. MOD. or DEFAULT SIG. MOD. Check wiring.
- Error 27, S. EE WRITE NAK** The channel's EEPROM could not be detected during a write operation. Check that the channel's address jumpers are set properly so that each card has a unique address.
- Error 28, S. EE READ NAK** The channel's EEPROM could not be detected during a read operation. Check that the channel's address jumpers are set properly.
- Error 29, S. EE VERIFY FAIL** A verification failure occurred during a write operation to the channel's EEPROM. Restart the instrument.
- Error 30, S. EE ERASE NAK** The channel's EEPROM could not be detected during an erase operation. Check that the channel's address jumpers are set properly.
- Error 31, BLANK IDENT** The channel does not appear to have been installed properly. This occurs if you swap Input or Output boards without using SYSTEM MENU -> INSTALL CHANNEL to format the channel's EEPROM.

- Error 32, BOGUS EE ADDR** An invalid address has been passed to the programmer. Restart the instrument. If this problem persists, contact Sensotec with the information found in the SYSTEM MENU -> SOFTWARE REV. menu item.
- Error 33, SIG. MOD WIRES** The instrument has detected that the (+)Signature and (-)Signature pins (labeled as "+MEM" and "-MEM") are likely reversed.
- Error 34, SIG. MOD MISMATCH** The excitation type byte found inside a *Signature Module* indicates that the channel is not designed to operate with that type of transducer.
- Error 35, BOGUS MENU TYPE** A menu contains an invalid menu type. Contact Sensotec with the information found in the SYSTEM MENU -> SOFTWARE REV. menu item.
- Error 36, BAD EE TABLE** The instrument doesn't understand the EEPROM type setting for the channel. Contact Sensotec with the information found in the SYSTEM MENU -> SOFTWARE REV. menu item.
- Error 37, BAD PERSONALITY** The channel doesn't understand the given card type. Contact Sensotec with the information found in the SYSTEM MENU -> SOFTWARE REV. menu item.
- Error 38, BAD FORMAT** The channel's EEPROM memory contains a display setting which is not understood by the instrument. Check that every item in the channel's DISPLAY SETUP menu has a valid setting.
- Error 39, WRONG HARDWARE** The channel type expected by the instrument for the channel number is not the channel type that is physically installed. If you have changed the address jumpers on one or more channels, replace them in their original configuration.
- Error 41, SHUNT CAL ERROR** The application of the shunt resistor did not affect the transducer's output. Check the wiring and the transducer output with a voltmeter to verify proper operation.
- If this is a Strain Gage Channel, make certain that the shunt calibration resistor installed on the circuit board is the correct value per the transducer's Calibration Record.
- If this is a High-Level Input Channel, make certain that the Shunt Cal 1 and Shunt Cal 2 pins are connected to the correct pins of the transducer/amplifier.
- Error 43, BAD IDENT CRC** A checksum failure has occurred when reading a channel's EEPROM. Restart the instrument.
- Error 44, BAD FUNCTION** The instrument has requested that the channel perform a function that it is not capable of. Restart the instrument.
- Error 45, A/D NAK** Hardware error. The channel's Analog-to-Digital converter is not communicating with the channel's microprocessor. Restart the instrument.
- Error 46, SENSE WIRES** The Strain Gage Channel's (+)Sense and (-)Sense pins (labeled as "+SEN" and "-SEN") are not connected to the (+)Excitation and (-)Excitation pins (labeled as "+EXC" and "-EXC"), respectively. This is most likely caused by the connector being unplugged from the channel.
- If you are not interested in the using this channel and you wish to surpress this error, see "DISABLE CHANNEL Menu Item" on page 75.
- Error 47, BAD EE TYPE REQ** When installing a channel, the EEPROM type requested by the channel is not valid. Contact Sensotec with the information found in the SYSTEM MENU -> SOFTWARE REV. menu item.

- Error 48, NULL MENU** A menu contains a NULL item. Contact Sensotec with the information found in the SYSTEM MENU -> SOFTWARE REV. menu item.
- Error 49, NULL ACTION FCN** A menu contains a NULL action function. Contact Sensotec with the information found in the SYSTEM MENU -> SOFTWARE REV. menu item.
- Error 50, EXCITATION** The channel's excitation voltage regulator has shut down because the protection circuit that limits the output current has activated. This is most likely caused by a short of the (+)Excitation and (-)Excitation pins (labeled as "+EXC" and "-EXC").
- Error 51, CAN'T DO EXC.** The channel's EEPROM memory contains an excitation setting which is not understood by the instrument. Change the channel's CALIBRATION DATA -> EXCITATION menu item to another setting.
- Error 52, SIG. MOD LENGTH R** An unexpected length byte was found inside a *Signature Module* during a read operation. Check the wiring.
- Error 53, SIG. MOD RECTYPE** An unexpected record type was found inside a *Signature Module* during a read operation. Check the wiring.
- Error 54, SIG. MOD LENGTH W** An unexpected record type was found inside a *Signature Module* during a write operation. Check the wiring and re-start the instrument.
- Error 55, SIG. MOD VERIFY SP** A data verification error occurred during a write operation to a *Signature Module's* scratchpad. Check the wiring and re-start the instrument.
- Error 56, SIG. MOD VERIFY** A data verification error occurred during a write operation to a *Signature Module*. Check the wiring and re-start the instrument.
- Error 57, WRONG SIG. MOD.** You have attempted to perform an UPDATE SIG. MOD. operation with a different *Signature Module* than what was connected when the instrument was powered up. Re-connect the original transducer/*Signature Module* and restart the instrument.
Another cause of this error is described in the description for Error 68 below.
- Error 58, WRONG EE VERSION** The channel's EEPROM memory data is not able to be used by this version of firmware. Make certain that you have not accidentally swapped channel circuit boards between instruments. If you are certain that you want to use the channel circuit board with this instrument, you may reset the channel's EEPROM memory data to factory defaults with the SYSTEM MENU -> DEFAULT CHANNEL menu item.
- Error 59, CAN'T DO SIG. MOD** A *Signature Module* is connected to a channel which doesn't support *Signature Calibration*. Only Strain Gage Input channels are designed to operate with *Signature Calibration*.
- Error 60, SLAVE TIMEOUT** The channel's microprocessor did not respond because the channel's analog-to-digital converter did not calibrate properly. Restart the instrument.
- Error 61, LOAD NOT GT LOAD** A load applied during a known-load calibration was not greater than a previously applied load. To insure both correct operation of the transducer and application of the load, the instrument expects the voltage applied at each known-load point to be increasing. For example, the load applied at Known-Load Point 2/2 must cause the transducer to produce a more positive voltage than at Known-Load Point 1/2.

If you are calibrating with a AC-AC LVDT Input channel, make certain that you have followed the procedure described in "Electrical Null and Transducer Mounting" on page 93.

Error 62, SLAVE NAK	The channel's microprocessor is responding to a message, but it did not acknowledge it correctly. Restart the instrument.
Error 67, LOADS NOT CLOSE	During a 5-Point Known-Load calibration, you would typically apply loads at 0%, 25%, 50%, 75% and 100% of the transducer's full-scale and optionally calibrate the return points of 75%, 50%, 25% and 0%. The instrument makes sure that transducer readings taken during the second application of the load are close to the readings taken during the first application of the load. This insures both correct operation of the transducer and application of the loads.
Error 68, CAN'T CALIBRATE	The instrument has detected that the transducer presently connected to the channel is different than the transducer the channel was last calibrated with. Ordinarily, the instrument would perform a Shunt Calibration or mV/V Calibration. However, since the channel's CALIBRATION TYPE menu item is set to one of the Known-Load Calibration settings, no calibration can take place. Either re-connect the original transducer or use the SETUP menu to perform a calibration.
Error 70, CAN'T DO GAIN	The channel's EEPROM memory contains an input range setting which is beyond the capabilities of the channel. Change the channel's CALIBRATION DATA -> FULL SCALE MV/V menu item to another setting.
Error 71, SLAVE CHECKSUM	The channel's microprocessor did not send a correct checksum to the instrument. Restart the instrument.
Error 72, CAN'T DO FILTER	The channel's EEPROM memory contains a frequency response setting which is not understood by the instrument. Change the channel's OPERATION -> FREQ. RESPONSE menu item to another setting.
Error 73, SLAVE NOT INIT	The channel's microprocessor has not yet been initialized by the instrument. Restart the instrument.
Error 74, SLAVE BAD REPLY	The channel's microprocessor replied with a message that was either not understood or different than expected. Restart the instrument.
Error 75, SLAVE NOT FOUND	The channel's microprocessor did not respond. Restart the instrument.
Error 81, OPERAND EXPECTED	The first step of a SensoCode program must be an Operand. The SensoCode program loaded in the Mathematics Virtual channel is invalid.
Error 82, BAD OPERAND	The SensoCode program loaded into a Mathematics Virtual channel contains a bad operand.
Error 83, BAD INSTRUCTION	The SensoCode program loaded into a Mathematics Virtual channel contains a bad instruction.
Error 84, BAD VALUE	A Mathematics Virtual channel has attempted to get a value from a channel not installed in the instrument.
Error 85, UNREACHABLE GOTO	The destination step of a "Go to" Instruction is beyond the end of the SensoCode program. The SensoCode program loaded in the Mathematics Virtual channel is invalid.
Error 87, GOTO NOT JUMP	The SensoCode program contains a "Go to" Instruction that has not been converted into a "Jump" Instruction. Restart the instrument.

Chapter 18

Setup Menu Reference

18.1 Navigation instructions

- Press [UP]+[DOWN] to enter the SETUP menu mode.
- Press [UP] to move up.
- Press [DOWN] to move down.
- Press [ENTER] to select an item.
- Press [EXIT] to re-start the instrument.

Table 18-1: SETUP Menu

CHANNEL 01 MENU	——	(menu varies according to channel type)
CHANNEL 02 MENU	——	(menu varies according to channel type)
CHANNEL 03 MENU	——	(menu varies according to channel type)
CHANNEL 04 MENU	——	(menu varies according to channel type)
CHANNEL 05 MENU	——	(menu varies according to channel type)
CHANNEL 06 MENU	——	(menu varies according to channel type)
CHANNEL 07 MENU	——	(menu varies according to channel type)
CHANNEL 08 MENU	——	(menu varies according to channel type)
CHANNEL 09 MENU	——	(menu varies according to channel type)
CHANNEL 10 MENU	——	(menu varies according to channel type)
CHANNEL 11 MENU	——	(menu varies according to channel type)
CHANNEL 12 MENU	——	(menu varies according to channel type)
CHANNEL 13 MENU	——	(menu varies according to channel type)
CHANNEL 14 MENU	——	(menu varies according to channel type)
CHANNEL 15 MENU	——	(menu varies according to channel type)
CHANNEL 16 MENU	——	(menu varies according to channel type)
CHANNEL 17 MENU	——	(menu varies according to channel type)
CHANNEL 18 MENU	——	(menu varies according to channel type)
CHANNEL 19 MENU	——	(menu varies according to channel type)
CHANNEL 20 MENU	——	(menu varies according to channel type)
CHANNEL 21 MENU	——	(menu varies according to channel type)
CHANNEL 22 MENU	——	(menu varies according to channel type)
CHANNEL 23 MENU	——	(menu varies according to channel type)
LIMIT 01 MENU	——	(see LIMIT MENU)
LIMIT 02 MENU	——	(see LIMIT MENU)
LIMIT 03 MENU	——	(see LIMIT MENU)
LIMIT 04 MENU	——	(see LIMIT MENU)
LIMIT 05 MENU	——	(optional)(see LIMIT MENU)
LIMIT 06 MENU	——	(optional)(see LIMIT MENU)
LIMIT 07 MENU	——	(optional)(see LIMIT MENU)
LIMIT 08 MENU	——	(optional)(see LIMIT MENU)
LIMIT 09 MENU	——	(optional)(see LIMIT MENU)
LIMIT 10 MENU	——	(optional)(see LIMIT MENU)
LIMIT 11 MENU	——	(optional)(see LIMIT MENU)
LIMIT 12 MENU	——	(optional)(see LIMIT MENU)
LIMIT 13 MENU	——	(optional)(see LIMIT MENU)
LIMIT 14 MENU	——	(optional)(see LIMIT MENU)
LIMIT 15 MENU	——	(optional)(see LIMIT MENU)
LIMIT 16 MENU	——	(optional)(see LIMIT MENU)
SYSTEM MENU	——	(see SYSTEM MENU)
SERIAL COM MENU	——	(see SERIAL COM MENU)
DISPLAY MENU	——	(see DISPLAY MENU)

Table 18-2: System Menu

SYSTEM MENU	SOFTWARE REVISION			page 41
	CONFIGURATION	<ul style="list-style-type: none"> — DISPLAY TYPE — CHANNEL 01 TYPE — CHANNEL 02 TYPE — CHANNEL 03 TYPE — CHANNEL 04 TYPE — CHANNEL 05 TYPE — CHANNEL 06 TYPE — CHANNEL 07 TYPE — CHANNEL 08 TYPE — CHANNEL 09 TYPE — CHANNEL 10 TYPE — CHANNEL 11 TYPE — CHANNEL 12 TYPE — CHANNEL 13 TYPE — CHANNEL 14 TYPE — CHANNEL 15 TYPE — CHANNEL 16 TYPE — CHANNEL 17 TYPE — CHANNEL 18 TYPE — CHANNEL 19 TYPE — CHANNEL 20 TYPE — CHANNEL 21 TYPE — CHANNEL 22 TYPE — CHANNEL 23 TYPE — LEAVE SUB-MENU 		page 41
	DIAGNOSTICS	<ul style="list-style-type: none"> — OUTPUT 1, PIN 14 — OUTPUT 2, PIN 15 — OUTPUT 3, PIN 16 — OUTPUT 4, PIN 17 — INPUT TEST — SCAN TIME — LEAVE SUB-MENU 	<ul style="list-style-type: none"> — ON — OFF — ON — OFF — ON — OFF — ON — OFF 	page 41
	INSTALL CHANNEL	<ul style="list-style-type: none"> — 65 STRAIN GAGE V — 66 STRAIN GAGE I — 67 HIGH-LEVEL V — 68 HIGH-LEVEL I — 6B LVDT V OUT — 6C LVDT I OUT — 90 LIMIT 01-04 — 91 LIMIT 05-08 — 92 LIMIT 09-12 — 93 LIMIT 13-16 — AB SPLIT DISPLAY — AE MATHEMATICS 		page 42
	DELETE CHANNEL			page 44
	LEAVE MENU			

Table 18-3: LIMIT MENU

LIMIT xx MENU	LIMIT. ENABLE	ON	page 55
		OFF	
	LIMIT. SETPOINT		page 55
	LIMIT. RETURN PNT		page 55
	LIMIT. ENERGIZE	SIGNAL>SETPOINT	page 55
		SIGNAL<SETPOINT	
		SIGNAL INSIDE	
		SIGNAL OUTSIDE	
	LIMIT. LATCHING	ON	page 57
		OFF	
LIMIT. CHANNEL		page 57	
LIMIT. SOURCE	TRACK	page 57	
	PEAK		
	VALLEY		
LEAVE MENU			

Table 18-4: SERIAL COMMUNICATIONS Menu

SERIAL COM MENU	INTERFACE	page 49
	ADDRESS	page 49
	BAUD RATE	page 49
	AUTO LINE-FEED	page 49
	TRANSMIT TEST	page 49
	LEAVE MENU	

Table 18-5: DISPLAY Menu for Models SC2000, SC2001

DISPLAY MENU	UPPER CHANNEL	page 51	
	LOWER CHANNEL	page 51	
	LOWER MODE	BLANK	page 51
		LIMITS 01-04	
		CHANNEL	
	DISPLAY DISABLE	ON	page 51
		OFF	
LEAVE MENU			

Table 18-6: DISPLAY Menu for Model SC3004

DISPLAY MENU	POWERON CHANNEL	page 52
	LEAVE MENU	

Table 18-7: Strain Gage Input Channel Menu

CHANNEL xx MENU	OPERATION	AUTO-ZERO	ON	page 63
			OFF	
		FREQ. RESPONSE	002. HERTZ/FAST	page 63
			002. HERTZ	
			008. HERTZ	
			016. HERTZ	
			032. HERTZ	
			050. HERTZ	
			100. HERTZ	
			250. HERTZ	
		500. HERTZ		
		800. HERTZ		
		POWER-ON SOURCE	TRACK	page 64
			PEAK	
			VALLEY	
	DISPLAY SETUP	LEAVE SUB-MENU		
		DISPLAY. DIGITS	5 DIGIT-BIPOLAR	page 65
			6 DIGIT-UNIPOLAR	
			7 DIGIT-UNIPOLAR	
		DISPLAY. DECPY	99999.	page 65
			9999.9	
			999.99	
			99.999	
			9.9999	
			.99999	
	AUX1 FUNCTION	DISPLAY. COUNTRY	00001	page 65
			00002	
			00005	
		00010		
		00020		
		00050		
		00100		
		00200		
DISPLAY. UNITS			page 65	
DISPLAY. AVERAGE		ON	page 65	
	OFF			
AUX2 FUNCTION	LEAVE SUB-MENU			
	DISABLED		page 59	
	TRACK HOLD			
	HIGH/LOW HOLD			
	HIGH/LOW CLEAR			
	TARE ON			
CALIBRATION TYPE	TARE OFF			
	DISABLED		page 59	
	TRACK HOLD			
	HIGH/LOW HOLD			
	HIGH/LOW CLEAR			
	TARE ON			
CALIBRATION TYPE	TARE OFF			
	TYPE=SHUNT CAL		page 67	
	TYPE=MU/V CAL			

Table 18-7: Strain Gage Input Channel Menu (Continued)

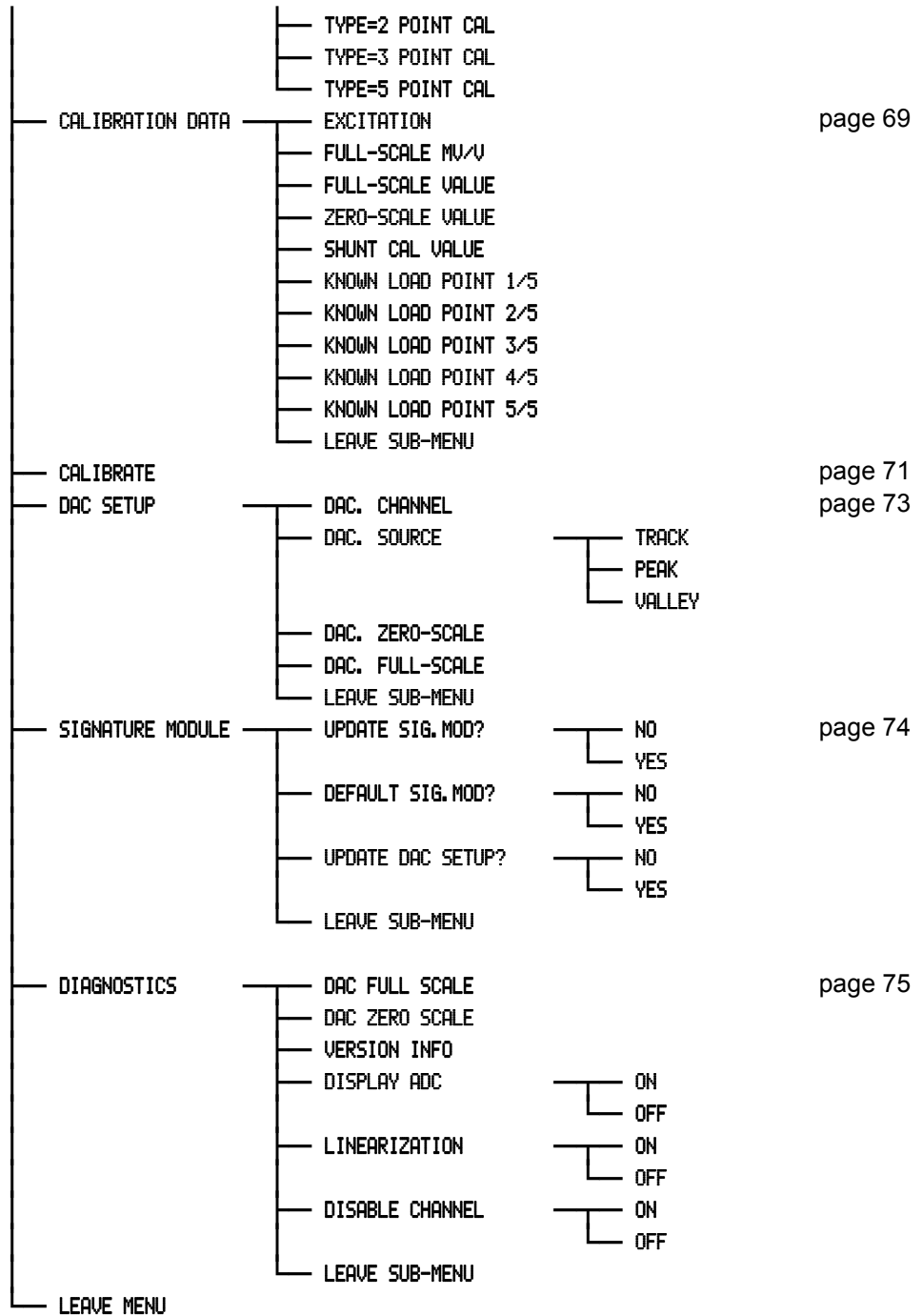

Table 18-8: AC-AC LVDT Input Channel Menu

CHANNEL xx MENU	OPERATION	AUTO-ZERO	ON	page 83
			OFF	
		FREQ. RESPONSE	002. HERTZ/FAST	page 83
			002. HERTZ	
			008. HERTZ	
			016. HERTZ	
			032. HERTZ	
			050. HERTZ	
			100. HERTZ	
			250. HERTZ	
		500. HERTZ		
		800. HERTZ		
		POWER-ON SOURCE	TRACK	page 84
			PEAK	
			VALLEY	
	DISPLAY SETUP	LEAVE SUB-MENU		
		DISPLAY. DIGITS	5 DIGIT-BIPOLAR	page 85
			6 DIGIT-UNIPOLAR	
			7 DIGIT-UNIPOLAR	
		DISPLAY. DECPT	99999.	page 85
			9999.9	
			999.99	
			99.999	
			9.9999	
			.99999	
	DISPLAY. COUNBY	00001	page 85	
		00002		
		00005		
	00010			
	00020			
	00050			
	00100			
	00200			
DISPLAY. UNITS		page 85		
DISPLAY. AVERAGE	ON	page 85		
	OFF			
LEAVE SUB-MENU				
AUX1 FUNCTION	DISABLED		page 85	
	TRACK HOLD			
	HIGH/LOW HOLD			
	HIGH/LOW CLEAR			
	TARE ON			
	TARE OFF			
AUX2 FUNCTION	DISABLED		page 85	
	TRACK HOLD			
	HIGH/LOW HOLD			
	HIGH/LOW CLEAR			
	TARE ON			
	TARE OFF			
CALIBRATION TYPE	TYPE=2 POINT CAL		page 87	
	TYPE=3 POINT CAL			

Table 18-8: AC-AC LVDT Input Channel Menu (Continued)

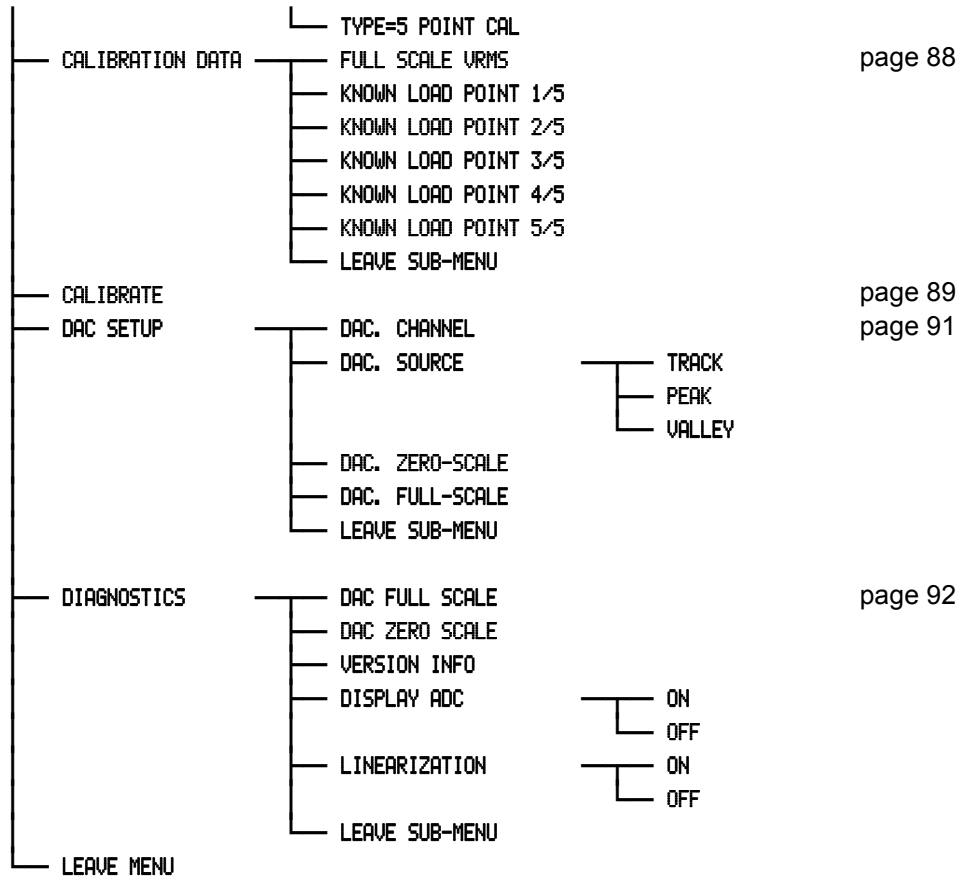

Table 18-9: High-Level Input Channel Menu

CHANNEL xx MENU	OPERATION	AUTO-ZERO	ON	page 108
			OFF	
		FREQ. RESPONSE	002. HERTZ/FAST	page 108
			002. HERTZ	
			008. HERTZ	
			016. HERTZ	
			032. HERTZ	
			050. HERTZ	
			100. HERTZ	
			250. HERTZ	
		500. HERTZ		
		800. HERTZ		
		POWER-ON SOURCE	TRACK	page 109
			PEAK	
			VALLEY	
	DISPLAY SETUP	LEAVE SUB-MENU		
		DISPLAY. DIGITS	5 DIGIT-BIPOLAR	page 110
			6 DIGIT-UNIPOLAR	
			7 DIGIT-UNIPOLAR	
		DISPLAY. DECPT	99999.	page 110
		9999.9		
		999.99		
		99.999		
		9.9999		
		.99999		
DISPLAY. COUNTRY	DISPLAY. COUNTRY	00001	page 110	
		00002		
		00005		
		00010		
		00020		
		00050		
		00100		
		00200		
DISPLAY. UNITS		page 110		
DISPLAY. AVERAGE	ON	page 110		
	OFF			
LEAVE SUB-MENU				
AUX1 FUNCTION	DISABLED	page 111		
	TRACK HOLD			
	HIGH/LOW HOLD			
	HIGH/LOW CLEAR			
	TARE ON			
	TARE OFF			
AUX2 FUNCTION	DISABLED	page 111		
	TRACK HOLD			
	HIGH/LOW HOLD			
	HIGH/LOW CLEAR			
	TARE ON			
	TARE OFF			
CALIBRATION TYPE	TYPE=SHUNT CAL	page 112		
	TYPE=2 POINT CAL			

Table 18-9: High-Level Input Channel Menu (Continued)

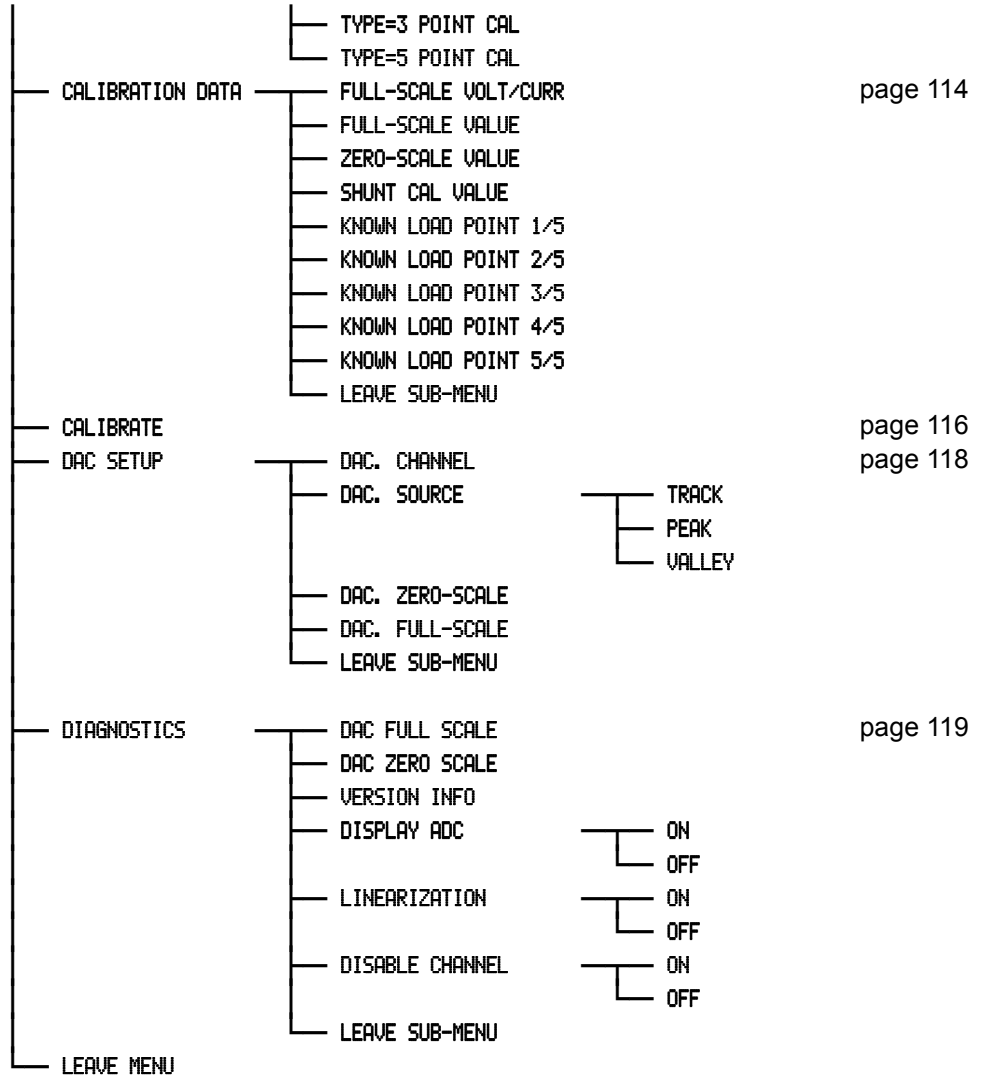

Table 18-10: Relay Output Channel

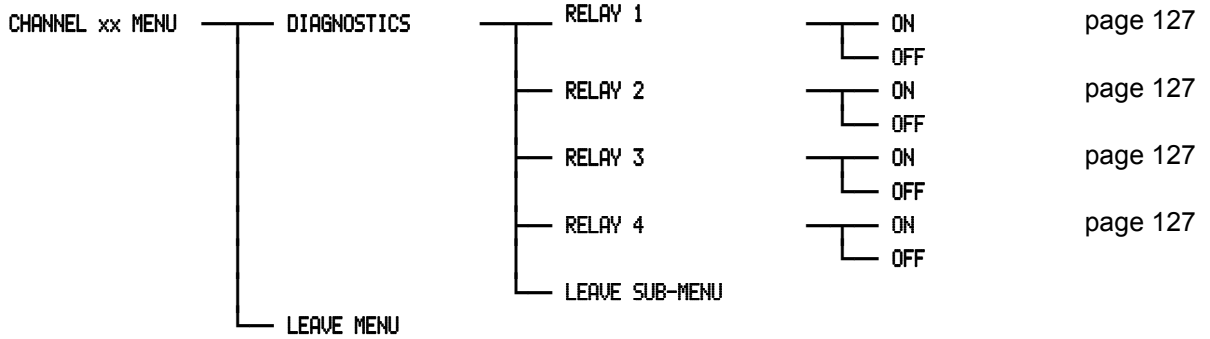

Table 18-11: DAC Output Channel Menu

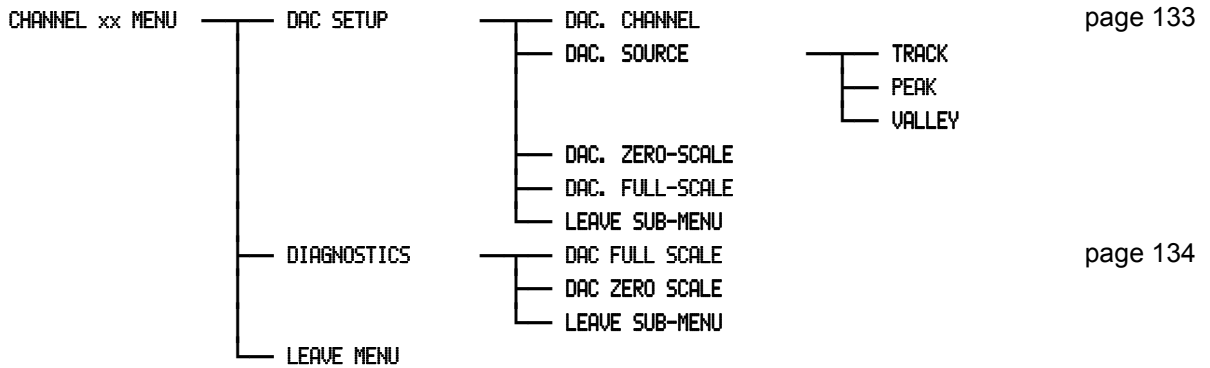

Table 18-12: Split Display Virtual Channel

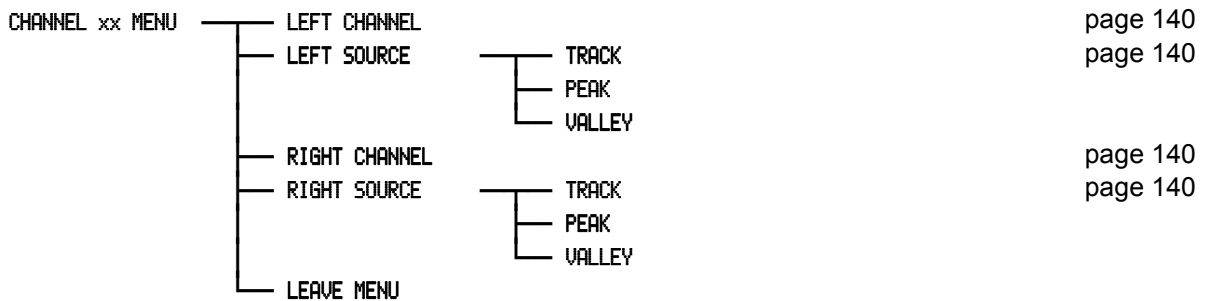

Table 18-13: Mathematics Virtual Channel

CHANNEL xx MENU	SENSOCODE P/N USER VALUES	USER VALUE 1	(item name may vary)	page 144	
		USER VALUE 2	(item name may vary)	page 144	
		USER VALUE 3	(item name may vary)		
		USER VALUE 4	(item name may vary)		
		LEAVE SUB-MENU			
	VIEW SENSOCODE				page 144
	VIEW COMMANDS	COMMAND 0			
		COMMAND 1			
		COMMAND 2			
		COMMAND 3			
		COMMAND 4			
		COMMAND 5			
		COMMAND 6			
		COMMAND 7			
	LEAVE SUB-MENU				
DISPLAY SETUP	DISPLAY. DIGITS	5 DIGIT-BIPOLAR		page 145	
		6 DIGIT-UNIPOLAR			
		7 DIGIT-UNIPOLAR			
	DISPLAY. DECP	99999.			page 145
		9999.9			
		999.99			
		99.999			
		9.9999			
	DISPLAY. COUNBY	.99999			
		00001			page 145
00002					
00005					
00010					
00020					
00050					
00100					
00200					
DISPLAY. UNITS				page 145	
DISPLAY. AVERAGE	ON			page 145	
OFF					
LEAVE SUB-MENU					
POWER-ON SOURCE	TRACK			page 146	
	PEAK				
	VALLEY				
	TRACK / PEAK	(SC3004 only)			
	TRACK / VALLEY	(SC3004 only)			
	PEAK / VALLEY	(SC3004 only)			
LEAVE MENU					

A

- AC/AC-LVDT Input channel 79
 - 2-Point Known Displacement Calibration 87–89
 - 3-Point Known Displacement Calibration 87–89
 - 5-Point Known Displacement Calibration 87–89
 - Analog Output 91–92, 94–95
 - auto-zero function 83
 - Auxilliary Function pins 85, 95
 - calibration procedure 81
 - calibration types comparison 87
 - display setup 85
 - Electrical Null 93
 - EMI/RFI interference 95
 - frequency response 83
 - OVER message 95
 - remote control of Track/Hold, Peak/Valley clear, Peak/Valley hold or Tare 85, 95
 - resolution 83
 - SETUP menu 83
 - software revision 92
 - specifications 82
 - step response time 83
 - Transducer Mounting 93
 - troubleshooting 95
 - wiring 80
- Analog Output
 - AC/AC-LVDT Input channel 91–92, 94–95
 - DAC Output channel 134–136
 - High-Level Input channel 118–121
 - Strain-Gage Input channel 73–77
 - auto-zero function
 - AC/AC-LVDT Input channel 83
 - High-Level Input channel 108
 - Strain-Gage Input channel 63
 - Auxilliary Function pins
 - AC/AC-LVDT Input channel 85, 95
 - High-Level Input channel 111, 122
 - Strain-Gage Input channel 66, 78

B

- buttons
 - CHANNEL 21
 - CLEAR 20, 57
 - DOWN 23
 - ENTER 23
 - EXIT 23
 - TARE 21

- UP 23
- VALUE 20

C

- calibration
 - AC/AC-LVDT Input channel 81
 - High-Level Input channel 106
 - Strain-Gage Input channel 61
- case removal
 - of SC1000 and SC2000 28
 - of SC2001 31
 - of SC3004 34
- channel
 - address jumpers 42
 - changing which is displayed 21, 51–52
 - clearing peak and valley 20
 - deleting last in instrument 44
 - Input 12
 - installation 42
 - list of all in instrument 41
 - Output 12
 - reset to default settings 44
 - types 12
 - Virtual 13
- CHANNEL button 21
- Chassis 25
- CLEAR button 20, 57
- Communications Guide 11, 47
- connectors
 - System 36
- Customer Information Sheet 11

D

- DAC Output channel 129
 - Analog Output 134–136
 - EMI/RFI interference 136
 - SETUP menu 133
 - setup procedure 131
 - specifications 132
 - troubleshooting 136
 - wiring 130
- display
 - averaging
 - AC/AC-LVDT Input channel 85
 - High-Level Input channel 110
 - Mathematics Virtual channel 145
 - Strain-Gage Input channel 65

- changing channel shown on 21, 51–52
- decimal points
 - AC/AC-LVDT Input channel 85
 - High-Level Input channel 110
 - Mathematics Virtual channel 145
 - Strain-Gage Input channel 65
- disabling 51
- lower line 20, 51
- OVER message
 - AC/AC-LVDT Input channel 95
 - High-Level Input channel 121
 - Strain-Gage Input channel 77
- percentage of Analog-to-Digital converter input 20
- symbols 20
- track, peak or valley 20
- units of measure
 - AC/AC-LVDT Input channel 85
 - High-Level Input channel 110
 - Mathematics Virtual channel 145
 - Strain-Gage Input channel 65
- when shunt calibration resistor applied 21
- DOWN button 23

E

- EMI/RFI interference
 - AC/AC-LVDT Input channel 95
 - DAC Output channel 136
 - High-Level Input channel 122
 - Strain-Gage Input channel 78
- ENTER button 23
- error messages 149
- ERROR mode 22
- excitation
 - Strain-Gage Input channel 69
- EXIT button 23

F

- frequency response
 - AC/AC-LVDT Input channel 83
 - High-Level Input channel 108
 - Strain-Gage Input channel 63
- fuse replacement
 - of SC1000 and SC2000 30
 - of SC2001 32
 - of SC3004 34

H

- High-Level Input channel 97
 - 2-Point Known Load Calibration 112, 114, 116
 - 3-Point Known Load Calibration 112, 114, 116
 - 5-Point Known Load Calibration 112–113, 115–116
- Analog Output 118–121
- auto-zero function 108
- Auxilliary Function pins 111, 122

- calibration procedure 106
- calibration types comparison 112
- display setup 110
- EMI/RFI interference 122
- frequency response 108
- OVER message 121
- remote control of Track/Hold, Peak/Valley clear, Peak/Valley hold or Tare 111, 122
- resolution 108
- SETUP menu 108
- Shunt Calibration 112, 114, 116
- software revision 119
- specifications 107
- step response time 108
- troubleshooting 121
- wiring 98

I

- indicator lights
 - limits 54
 - lower line display of 51
 - Tare 21
- INITIALIZE mode 19
- installation of channels 42

L

- LEDs. See indicator lights.
- lights. See indicator lights.
- limits
 - clearing latched limits 20
 - enabling 55
 - indicator lights
 - latching 57
 - Limits 01-04 54, 123
 - Limits 05-08 54, 123
 - Limits 09-12 54, 123
 - Limits 13-16 54, 123
 - open-collector outputs 38
 - operation 54–55, 57
 - Relay Output channels 54
 - scan time 54
 - SETUP menu 55
 - wiring 36
- LVDT Input channel
 - See AC/AC-LVDT Input channel

M

- Mathematics Virtual channel 141
 - display setup 145
 - operation 143
 - SensoCode 141
 - part number 144
 - viewing program 144
 - SETUP menu 144

- troubleshooting 147
- user values 144
- wiring 142

menu. See SETUP menu mode.

O

- operating modes 19
 - ERROR 22
 - INITIALIZE 19
 - RUN 20
 - SETUP menu 23
- OVL message
 - AC/AC-LVDT Input channel 95
 - High-Level Input channel 121
 - Strain-Gage Input channel 77

P

- panel mounting
 - of SC1000 and SC2000 27
 - of SC3004 33
- Peak/Valley values
 - AC/AC-LVDT Input channel 83
 - displaying 20
 - High-Level Input channel 108
 - remote clearing of all 36
 - Strain-Gage Input channel 63

Q

- quick start 15

R

- rack mounting
 - of SC1000 and SC2000 28
- Relay Output channel 123
 - diagnostics 127
 - SETUP menu 127
 - specifications 126
 - wiring 124
- remote control. See Auxilliary Function pins 66, 85, 111
- resolution
 - AC/AC-LVDT Input channel 83
 - High-Level Input channel 108
 - Strain-Gage Input channel 63
- RS-232
 - wiring 36
- RS-232. See Serial Communications
- RS-485
 - wiring 36
- RS-485. See Serial Communications
- RUN mode 20

S

- SC Series

- features 12
- SC1000 20, 27
- SC2000 27
- SC2001 31
- SC3004 33, 139
- SensoCode 141
 - part number 144
 - software revision 144
 - viewing 144
- Serial Communications 47
 - communications parameters 48–49
 - RS-232 defined 48
 - RS-485 defined 48
- Serial Communications Guide 11
- SETUP menu mode
 - navigation instructions 155
 - overview 23
 - reference 156
- shunt calibration check 21
- Signature Calibration
 - defined 14
 - with Strain-Gage Input channel 67, 74
- Signature Module 74
 - defaulting to factory settings 74
 - updating channel's Analog Output settings 74
 - writing with information from SETUP menus 74
- software revision
 - AC/AC-LVDT Input channel 92
 - chassis 41
 - High-Level Input channel 119
 - Mathematics Virtual channel 144
 - SensoCode program 144
 - Strain-Gage Input channel 75
- specifications
 - AC/AC-LVDT Input channel 82
 - Chassis Models 26
 - DAC Output channel 132
 - High-Level Input channel 107
 - Relay Output channel 126
 - Strain-Gage Input channel 62
- Split Display Virtual channel 139
 - display formatting 139
 - SETUP menu 140
- step response time
 - AC/AC-LVDT Input channel 83
 - High-Level Input channel 108
 - Strain-Gage Input channel 63
- Strain-Gage Input channel
 - 2-Point Known Load Calibration 67–68, 70–71
 - 3-Point Known Load Calibration 67–68, 70–71
 - 5-Point Known Load Calibration 67–68, 70, 72
 - Analog Output 73–77
 - auto-zero function 63
 - Auxilliary Function pins 66, 78
 - calibration procedure 61
 - calibration types comparison 67
 - display setup 65

- EMI/RFI interference 78
- excitation 69
- frequency response 63
- mV/V Calibration 67–68, 71
- OVER message 77
- remote control of Track/Hold, Peak/Valley clear, Peak/Valley hold or Tare 66, 78
- resolution 63
- SETUP menu 63
- Shunt Calibration 67, 69, 71
- software revision 75
- specifications 62
- step response time 63
- troubleshooting 77
- wiring 60

- System Connector
 - diagnostics 41
 - pinout 36

T

Tare

- activating or deactivating 21
- remote of all channels 36
- See also Auxilliary Function pins.

- Tare light 21
- troubleshooting
 - AC/AC-LVDT Input channel 95
 - DAC Output channel 136
 - High-Level Input channel 121
 - Strain-Gage Input channel 77

U

- UP button 23
- user values 144

V

- VALUE button 20

W

wiring

- AC/AC-LVDT Input channel 80
- DAC Output channel 130
- High-Level Input channel 98
- Mathematics Virtual channel 142
- Relay Output channel 124
- Strain-Gage Input channel 60

Warranty/Repair Policy

Limitation of Remedy and Disclaimer of Warranty

Any of our products which, under normal operating conditions, proves defective in material or in workmanship within one year from the date of shipment by Sensotec, Inc., will be repaired or replaced free of charge, provided that the buyer (1) promptly notifies Sensotec, Inc. of any such defect; (2) provides Sensotec, Inc. with satisfactory proof of the defect and that the product was properly installed, maintained, and operated within the limits of rated and normal usage; and (3) obtains from Sensotec, Inc. authorization to return the product. Any such product shall be returned with transportation charges prepaid. The replacement product will be shipped F.O.B. our plant.

The remedy set forth herein does not extend to any product or part thereof which, under normal usage, has an inherently shorter useful life than one year. The remedy set forth herein does not apply to damage or to defects in any product caused by the buyer's misuse or neglect, nor does it apply to any product which has been repaired or disassembled which, in the sole judgement of Sensotec, Inc. affects the performance of the product.

The remedy set forth herein is the buyer's exclusive remedy, and will satisfy all obligations of Sensotec, Inc. whether based on contract, negligence, or otherwise. Sensotec, Inc. is not responsible for any incidental or consequential loss or damage which might result from a failure of any Sensotec, Inc. product.

THIS EXPRESS WARRANTY IS MADE IN LIEU OF ANY AND ALL OTHER WARRANTIES, EXPRESSED OR IMPLIED, INCLUDING IMPLIED WARRANTY OF MERCHANTABILITY OR FITNESS FOR PARTICULAR PURPOSE.

Obtaining Service Under Warranty

Advanced authorization is required prior to the return to Sensotec, Inc. Before returning the items, either write to the Repair Department c/o Sensotec, Inc., 2080 Arlingate Lane, Columbus, Ohio 43228, or call (800) 848-6564 with: 1) a part number; 2) a serial number of the defective product; 3) a technical description* of the defect; 4) a no-charge purchase order number (so products can be returned to you correctly); and 5) ship and bill addresses. Shipment to Sensotec, Inc. shall be at Buyer's expense and repaired or replacement items will be shipped F.O.B. our plant in Columbus, Ohio. Non-verified problems or defects may be subject to an evaluation charge. Please return the original calibration data with the unit.

Obtaining Non-warranty Service

Advance authorization is required prior to the return to Sensotec, Inc. Before returning the item, either write to the Repair Department c/o Sensotec, Inc., 2080 Arlingate Lane, Columbus, Ohio 43228, or call (800) 848-6564 with: 1) a part number; 2) a serial number of the defective product; 3) a technical description* of the malfunction; 4) a purchase order number to cover Sensotec, Inc.'s repair cost; and 5) ship and bill addresses. After the product is evaluated by Sensotec, Inc., we will contact you to provide the estimated repair costs before proceeding. The minimum evaluation charge is \$95. Shipment to Sensotec, Inc. shall be at Buyer's expense and repaired items will be shipped to you F.O.B., our plant in Columbus, Ohio. Please return the original calibration data with the unit.

Repair Warranty

All repairs of Sensotec, Inc. products are warranted for a period of 90 days from date of shipment. This warranty applies only to those items which were found defective and repaired. It does not apply to products in which no defect was found and returned as is or merely re-calibrated. Out of warranty products may not be capable of being returned to the exact original specifications or dimensions.

*Technical description of the defect: In order to properly repair a product, it is necessary for Sensotec, Inc. to receive information specifying the reason the product is being returned. Specific test data, written observations on the failure and specific corrective action you require is needed.

SENSOTEC

(800)848-6564

2080 Arlingate Lane
Columbus, Ohio 43228

Tel: (614)850-5000

Fax: (614)850-1111

E-mail: service@sensotec.com

<http://www.sensotec.com>