

ENDURANCE: THE REWARDS AND CHALLENGES OF LANDING A SPACECRAFT ON EUROPA

A. Rager⁽¹⁾, T. R. Hanley⁽²⁾, C. Calvin⁽³⁾, T. Balint⁽⁴⁾, D. Santiago⁽⁵⁾, J. Anderson⁽⁶⁾, T. Cassidy⁽⁷⁾,
D. Chavez-Clemente⁽⁸⁾, B. M. Corbett⁽⁹⁾, H. Hammerstein⁽¹⁰⁾, A. Letcher⁽¹¹⁾, E. M. McGowan⁽¹²⁾,
D. S. McMenamin⁽¹³⁾, N. Murphy⁽¹⁴⁾, M. D. Obland⁽¹⁵⁾, J. S. Parker⁽¹⁶⁾, T. Perron⁽¹⁷⁾, N. Petro⁽¹⁸⁾,
M. Pulupa⁽¹⁹⁾, R. Schofield⁽²⁰⁾, and H. G. Sizemore⁽²¹⁾

- ⁽¹⁾ UNLV, Dept of Geoscience, Las Vegas, NV 89154-4010 (U.S.A.), Email: ahrager@unlv.nevada.edu
⁽²⁾ Georgia Institute of Technology, School of Electrical and Computer Engineering, Atlanta, GA, 30332-0250, (U.S.A.), Email: gtg237n@mail.gatech.edu
⁽³⁾ Brown University, Dept of Geo Science 324 Brook Street, Box 1846, Providence, RI 02905, (U.S.A.), Email: Christina_Calvin@brown.edu
⁽⁴⁾ JPL/CalTech, 4800 Oak Grove Drive Mail Stop 301-170U, Pasadena, CA 91109 (U.S.A.), Email: Tibor.Balint@jpl.nasa.gov
⁽⁵⁾ UC Santa Cruz, Dept of Earth Sciences, Santa Cruz, CA 95064 (U.S.A.), Email: santiago@es.ucsc.edu
⁽⁶⁾ Winona State Univ, Dept of Geosciences, Winona, MN 55987 (U.S.A.), Email: JAnderson@winona.edu
⁽⁷⁾ Univ of Virginia, Dept of Environmental Sciences, Charlottesville, VA 22904-4123 (U.S.A.), Email: tac2z@virginia.edu
⁽⁸⁾ Stanford Univ, Dept of Aeronautical Engineering, Stanford, CA 94305-4035 (U.S.A.), Email: dchavez@stanford.edu
⁽⁹⁾ Univ of Denver, Dept of Engineering and Materials Science, Denver, CO 80208 (U.S.A.), Email: bmyers@du.edu
⁽¹⁰⁾ Gulfstream Aerospace, Gulfstream Aerospace Corp., Savannah, GA 31407, (U.S.A.), Email: Heidi_Hammerstein@hotmail.com
⁽¹¹⁾ Stanford Univ, School of Earth Sciences, Stanford, CA 94305 (U.S.A.), Email: aletcher@stanford.edu
⁽¹²⁾ UMass, Amherst, Dept of Geosciences, Amherst, MA 01003-9297 (U.S.A.), Email: emcgowan@geo.umass.edu
⁽¹³⁾ UMass, Amherst, Dept of Geosciences, Amherst, MA 01003-9297 (U.S.A.), Email: dianna@geo.umass.edu
⁽¹⁴⁾ Univ of Colorado, Dept of Astrophysics and Planetary Science, Boulder, CO 80309 (U.S.A.), Email: nmurphy@lasp.colorado.edu
⁽¹⁵⁾ Montana State Univ, Department of Physics, Bozeman, MT 59717 (U.S.A.), Email: obland@physics.montana.edu
⁽¹⁶⁾ Univ of Colorado, Aerospace Engineering Sciences, Boulder, CO 80309 (U.S.A.), Email: parkerjs@colorado.edu
⁽¹⁷⁾ UC Berkeley, Department of Earth & Planetary Science, Berkeley, CA 94720 (U.S.A.), Email: perron@eps.berkeley.edu
⁽¹⁸⁾ Brown University, Dept of Geo Science 324 Brook Street, Box 1846, Providence, RI 02905 (U.S.A.), Email: Noahpetro@brown.edu
⁽¹⁹⁾ UC Berkeley, Space Sciences Lab, Berkeley, CA 94720-4767 (U.S.A.), Email: pulupa@ssl.berkeley.edu
⁽²⁰⁾ Univ of Colorado, NOAA-David Skaggs Research Center, Boulder, CO 80309 (U.S.A.), Email: Robyn.Schofield@noaa.gov
⁽²¹⁾ Univ of Colorado, Dept of Astrophysics and Planetary Science, Boulder, CO 80309 (U.S.A.), Email: hanna.sizemore@colorado.edu

ABSTRACT

The possibility that a water ocean exists beneath Europa's icy shell makes it one of the most likely places in our solar system for life to have formed and prospered. In this study, we discuss "Endurance," a proposed lander mission to Europa, and the issues involved in landing a spacecraft on the surface of Europa. Our lander was designed to

meet the science objectives laid out in the Jupiter Icy Moons Orbiter (JIMO) Science Definition Team (SDT) Report [1], namely to: 1) assess the habitability of the environment beneath the surface of Europa; 2) assess the geochemical and physical structure of the surface of Europa and provide ground truth for orbital studies; and 3) provide ground based geophysical studies of Europa's icy shell. Additionally, the mission is designed to

assess surface conditions, such as surface structure and radiation levels, for future Europa lander missions. Although much can be learned from this mission, landing on Europa presents many challenges such as radiation, extreme cold, and the need to decontaminate the spacecraft to meet planetary protection requirements. Despite the harsh environment, the Endurance lander demonstrates the feasibility of landing and collecting valuable scientific data of the surface of Europa.

1. INTRODUCTION

In July, 2005, 20 Ph.D. students and recent Ph.D. graduates attended NASA's 17th Annual Planetary Science Summer School at the Jet Propulsion Laboratory. During this one-week intensive team exercise, the primary goal was to learn the process of developing a robotic mission concept into reality through concurrent engineering. Thus, with the guidance of Tibor Balint (JPL) and with the help of Team X, our team carried out a design exercise for a Europa lander mission concept.

This paper describes the science objectives, science payload, landing site selection, mission design, and lander design that resulted from this effort. In addition, the challenges of designing such a mission are discussed.

2. SCIENCE OBJECTIVES

Science objectives for this mission are adapted from [1] and [2] and include astrobiological, geophysical, and geochemical and physical structure of Europa's surface. In addition, a major objective of this study is to gather information that will help develop mission requirements for future missions.

2.1 Astrobiology

If Europa's subsurface is composed of liquid water, Europa will be one of the most likely places in the solar system for life to have developed. Therefore, astrobiological studies are at the forefront of this mission. These studies are loosely grouped into two types. The first looks for direct evidence that life existed on Europa in the past and/or continues to thrive today. These indicators, which are measured through direct chemical analysis at the surface, include the presence of complex and/or chiral compounds, stable isotopic signatures, etc. The second type of study will look at the conditions necessary for life to develop. This includes assessments of the physical properties of

the subsurface, the magnetic field at the surface, etc.

2.2 Geophysics

The nature of Europa's physical structure provides a great number of unanswered questions including how thick is Europa's crust, what is the chemical and physical nature of the mantle beneath the icy shell, how does the magnetic field vary at the surface relative to orbital data, and how does the crust of Europa deform. This mission will constrain the answers to these questions through a combination of seismic and magnetic studies at the surface. Tab. 1. List of instruments and the science objectives they support.

Tab. 1. Instruments and Associated Science Objectives (A = Astrobiology; B = Geophysics; C = Geochemistry & Geomorphology; and D = Future Mission Support)

Instrument	Science Objective (<i>DS</i> = Direct Support; <i>IS</i> = Indirect Support)			
	A	B	C	D
Seismometer	<i>IS</i>	<i>DS</i>	<i>IS</i>	<i>IS</i>
Magnetometer	<i>IS</i>	<i>DS</i>		
Cameras	<i>IS</i>		<i>DS</i>	<i>DS</i>
Surface Grinder	<i>IS</i>		<i>IS</i>	<i>IS</i>
Microscopic Imager	<i>DS</i>		<i>DS</i>	
Geochemical Analysis Device	<i>DS</i>		<i>DS</i>	
Radiation sensor	<i>IS</i>		<i>IS</i>	<i>DS</i>

2.3 Geochemistry/Geomorphology

Current understanding of Europa's surface comes from orbital data. However, several important issues remain including the nature of salts integrated into the icy matrix, the ratio of contamination in the ice, etc. Developing an understanding of the chemical nature of the icy crust and interior will allow models of tectonic activity of Europa's crust to be refined. In addition, chemical studies of Europa's crust will provide ground truth for orbital missions.

2.4 Future Mission Support

In addition to these scientific objectives, this mission is designed to assess surface conditions for future missions. Placing a lander on the surface of Europa comes with many complex challenges. The cold surface temperature means that the surface is extremely hard, the lack of atmosphere makes landing a significant challenge, and the high

radiation means that the instruments have a short life span once they reach the surface. Therefore, this mission will gather data on surface conditions such as temperature, radiation level, ice structure and hardness. This will allow designs for future lander missions to be tailored to the specific hazards of Europa's surface.

3. SCIENCE PAYLOAD

The payload of Endurance consists of a suite of seven instruments capable of addressing the previously stated objectives. There is redundancy in the instruments that allows for the majority of each science objective to be met even in the event of a single instrument failure. The original design called for a ground penetrating radar, but due to mass and size constraints it was determined that radar would be a greater asset on an orbiter.

3.1 Broadband Seismometer

The broadband seismometer is the most important instrument on Endurance in that it either directly or indirectly addresses all four of the science goals. The seismometer is tri-axial and determines the amplitude and direction of high and low frequency seismic waves. It can verify the existence of a subsurface ocean by characterizing seismic activity, including high frequency oscillations due to ice cracking and surface impacts and low frequency flexing due to the Jovian gravitational field. It has a relatively high mass (2.3 kg) and requires a deployment mechanism to place it in solid contact with the European surface. It would also require several days of operating time to measure tidal flexing during the 3.5 day revolution period.

3.2 Magnetometer

The other instrument that addresses the geophysical goals of the mission is a magnetometer. A magnetometer would be able to verify and characterize Europa's magnetic induction field due to a subsurface ocean and the time varying field of Jupiter's origin while producing continuous time series records of the vector magnetic field near Europa. Two light-weight fluxgate magnetometers (~0.2 kg each), one placed on a boom halfway down its length, and the other at the tip would be capable of measuring at least 10 vectors/second. The magnetometers operate on DC and require low power (1 W) electronics within the bus.

3.3 Cameras

Endurance is equipped with four cameras with multispectral imagers and a descent imager used for hazard avoidance, landing site determination, and geomorphology characterization. The original

design called for a panoramic camera mounted on a mast, but the mast exceeded the mass allocations. Instead, four cameras were chosen, three equidistant on the center support structure and one mounted to view a footpad for surface characterization. Each camera weighs approximately 0.26 kg, uses 3 W of power and is of similar heritage to the HazCam flown on MER. The cameras are used mainly for broadside-looking surface imaging and are an excellent tool for education and public outreach.

3.4 Microscopic Imager

For a closer look at the European surface, Endurance uses a microscopic imager mounted on the underside of the spacecraft. The 0.5 kg device uses about 3 W of power and will allow greater insight into the surface composition and structure as well as any potential astrobiological finds.

3.5 Surface Grinder

A surface grinder similar to the Rock Abrasion Tool (RAT) flown on MER is also included in the Endurance design. This apparatus would be lowered from the spacecraft to abrade the surface to assess its hardness and to release particles that could be characterized by the microscopic imager. The grinder has a mass of approximately 0.7 kg and uses 11 W of power. Additional development is required to allow the grinder to be able to efficiently abrade the cold, hardened surface.

3.6 Geochemical Analysis Device

In order to assess the European surface composition, a geochemical analysis device similar to the Plasma Experiment for Planetary Exploration (PEPE) flown on Deep Space I was chosen. The geochemical analysis device is capable of measuring and resolving the velocity distribution of electrons and ions and the mass composition of ions near Europa and in the Jovian magnetosphere in general. It resolves energy, angle, and mass & charge composition by using toroidal electrostatic angular scanning and energy/charge analyzers coupled to a linear-electric-field time-of-flight ion mass/charge analyzer. The instrument has a mass of approximately 5.5 kg, and requires less than 10 W of power, with a maximum data rate of 1.0 kbps. It has pointing requirements and preferred mounting locations on the spacecraft.

3.7 Radiation Sensor

The greatest asset Endurance provides to future mission planning is the data taken by its radiation sensor. It is able to measure high energy radiation doses while using very little power, mass, and volume. The radiation sensor would run

continuously, generating 172,800 bits of data per day. Additional data on the surface radiation environment would be obtained through the degradation of the cameras' optics, and potential degradation of electronics inside the vault.

4. LANDING SITE SELECTION

Europa's rugged terrain makes landing site selection difficult. Fig. 1 shows a variety of rough textures that dominate the surface of Europa. Locating a safe landing site which will also support Europa science objectives is even more challenging. A landing site must be relatively smooth and flat and encompass an area large enough for a landing ellipse. The authors followed the recommendation of Castalia Macula by Prockter and Schenk [3] as a landing site (Fig. 2).

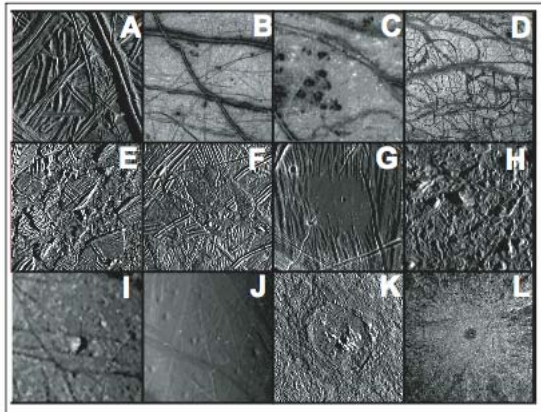

Fig. 1. Various Landscapes and Features on Europa: A = Ridges and Lineaments (27 m/pixel); B = Triple Bands (1.6 km/pixels); C = Dark Spots; D = "Pull-apart" Terrain (1.6 km/pixel); E = "Raft" Terrain (250 m/pixel); F = Flows (225 m/pixel); G = "Puddle" (27 m/pixel); H = Mottled Terrain (35 m/pixel), I = Knobs (1.6 km/pixel); J = Pits (1.6 m/pixel), K = Crater (300 m/pixel), L = Crater Ejecta. (Adapted from NASA Planetary Science Photojournal Image PIA00746 (<http://photojournal.jpl.nasa.gov>))

Prockter and Schenk [3] recommended Castalia Macula (Fig. 2) as a landing site for a future lander mission to Europa for two reasons. First, Castalia Macula is a relatively low-risk place to land. Second, topographic and geologic mapping of the Macula indicates it may include material that has been recently erupted from the subsurface, making it a good place to sample material that may have

been in communication with Europa's putative subsurface ocean.

Castalia Macula (1.6° S, 225.7° W) is a depression about 350 m deep and 30km in diameter [3]. The Macula encompasses about 600m², making it large enough to accommodate the landing ellipse. Its smooth texture indicates the Macula is relatively smooth and flat. The smooth texture and large size make Castalia Macula a relatively safe place to land.

The dark and reddish material filling the Macula stands out against its lighter and more textured surroundings [3]. Castalia Macula is bounded by two large uplifted domes to the north (900 m high) and south (750 m high). Although superposition and topographic relationships indicate that Castalia Macula is older than the adjacent domes and the relatively young Pwyll impact crater, the albedo, color, and lack of cross-cutting features suggest that the Macula and domes are relatively young [3].



Fig. 2. Castalia Macula ((1.6° S, 225.7° W). (Image from PDS Map-A-Planet, <http://pdsmaps.wr.usgs.gov/maps.html>).

In addition to providing a relatively safe landing site, Castalia Macula meets many of the criteria for meeting astrobiological science goals on Europa set forth by [4] including evidence of high material mobility, concentration of non-ice components, and relative youth. These features also make it a good location to support the geochemistry science objective. The relatively smooth, flat surface should ensure safe deployment of the seismometers and promote communication with the orbiter to support the geophysics science objective.

Although Castalia Macula is a topographic depression, it is surrounded by high domes; this large variation in topography should enable the cameras to image the landscape in support of the geomorphology science goal.

5. MISSION DESIGN

This section summarizes the Endurance Lander mission and associated challenges and assumptions.

5.1 Challenges

Design of a lander mission to Europa poses many challenges including planetary protection, radiation shielding, and landing.

Since determining whether chemical evidence of life exists on Europa is a primary science goal, forward contamination is of utmost concern. However, the one-week time frame for design of this mission did not afford us an opportunity to adequately address this issue.

Because it is situated within Jupiter's magnetosphere, Europa has an extremely high radiation environment. This makes it necessary to include radiation shielding around the instruments and electronics, essentially enclosing them in a vault. In spite of the shielding, the high radiation environment results in shorter lifespan for instruments.

Europa has virtually no atmosphere. Therefore, a propulsive landing is required. The increased mass from radiation shielding and greater delta V increases the wet mass of the propulsion system.

5.2 Assumptions

The Endurance lander was designed during the first one-week session of the 2005 NASA/JPL Planetary Science Summer School. The orbiter was designed by another team of students during the second one-week session. The Endurance lander and mission design are based upon several assumptions about the orbiter. These assumptions include (1) 110° retrograde orbit, (2) 100 km circular orbit, (3) Orbital period = 125.6 minutes, (4) ~30 day nominal mission, (5) ~5.25 AU from Earth, (6) Will provide landing site validation, and (7) Science payload will complement lander.

5.3 Mission Design Summary

Fig. 3 summarizes the Endurance Lander mission launch and VEEGA cruise. Separation of the Endurance Lander from the orbiter and the lander's entry, descent, and landing are summarized in Fig. 4 and Fig. 5.

The Endurance orbiter/lander mission will launch on December 2, 2014 with a VEEGA Cruise lasting 7.76 years. The spacecraft will intercept Jupiter's orbit on about September 5, 2022; Europa Orbital Insertion will occur about June 7, 2023. The spacecraft will orbit Europa approximately 8 days during which time it will gather images to validate the primary landing site within Castalia Macula.

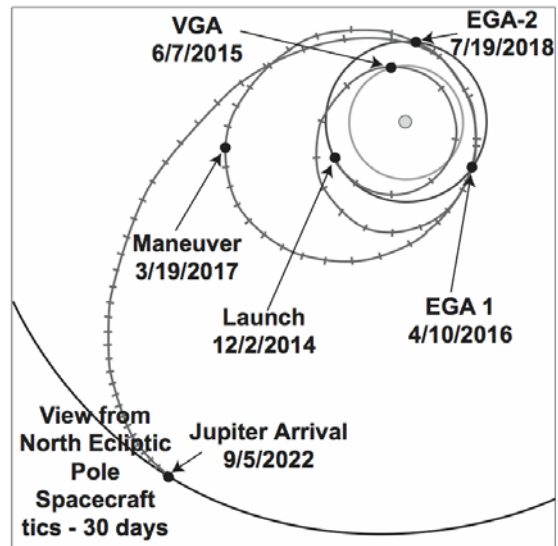

Fig. 3. Endurance launch and VEEGA cruise schedule.

Landing will occur on about June 15, 2023. Endurance's deorbit burn will begin 30 sec after separation from the orbiter at a 100 km parking orbit and last 42 sec. After exiting the 100 km parking orbit, Endurance will coast for 49.3 min and execute its stop burn for 668 sec. At the end of the stop burn at an altitude of 2 km, Endurance will reorient for landing. Endurance will then go through a 50 sec free fall to an altitude of 700 m with a radar altimeter and descent imager active. During a powered descent lasting 20 seconds, the Endurance lander will have hover and ~2000 m divert capability. Engine cutoff will occur at 10 m altitude with touchdown at T = 62.35 min after separation. Most science instruments have a 3.5-day lifetime, while the seismometer has a 7 – 14 day lifetime.

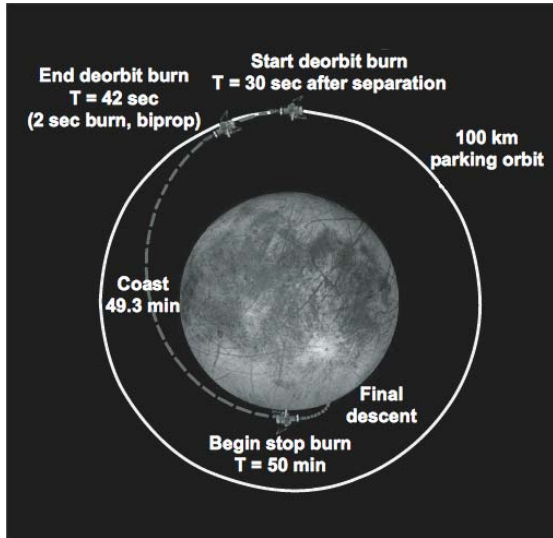

Fig. 4. Endurance lander separation from orbiter, entry, and descent.

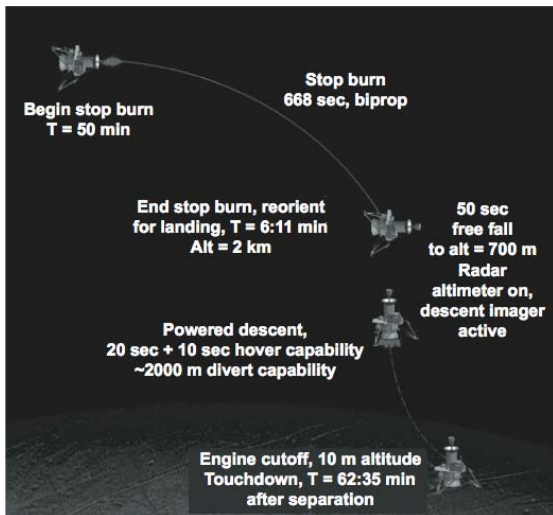

Fig. 5. Endurance landing.

6. ENDURANCE LANDER

JPL/NASA Planetary Science Summer School students who co-authored this paper worked with JPL's TeamX to design the Endurance Europa lander. The lander and its launch and landed configurations are shown in Fig. 6 and Fig. 7.

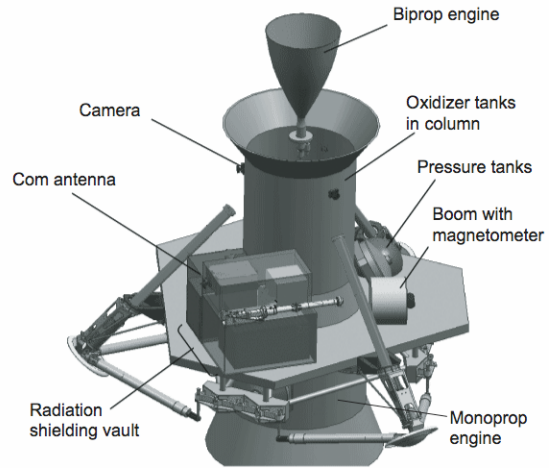

Fig. 6. Endurance Europa lander.

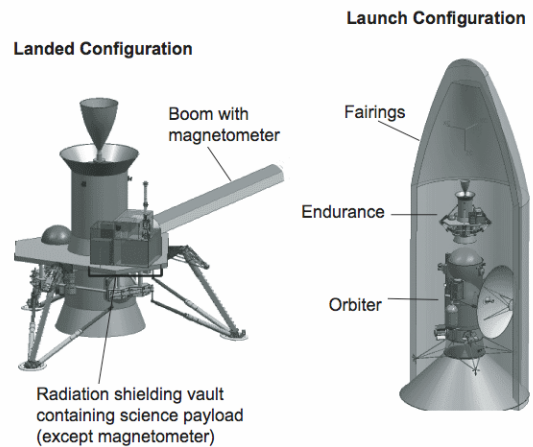

Fig. 7. Endurance landed configuration and launch configuration.

Fig. 8 shows the final mass budget for the Endurance lander. The final mass of the Endurance lander is about 820 kg, 320kg more than the 500kg goal (Fig. 9).

In an attempt to reduce the mass of the lander to 500kg or less, some instruments were descope. Mass of a Europa lander with a minimum number of instruments to cover the science floor was about 680 kg (Fig. 9). Finally, all instruments, except those required for landing (i.e., altimeter and descent imager) were dropped. The result was an "empty box" with a mass of about 640 kg (Fig. 9).

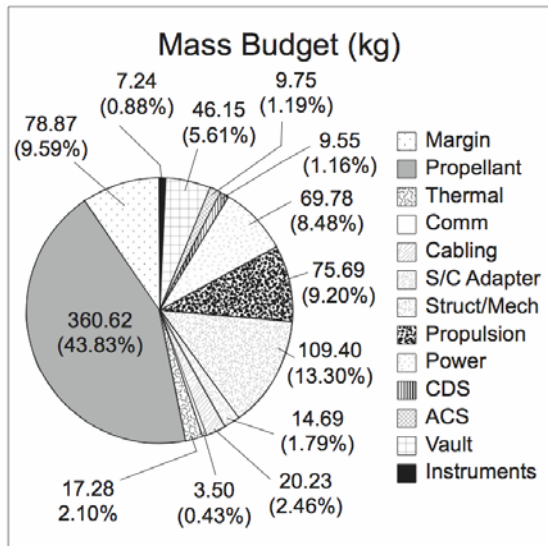

Fig. 8. Endurance mass budget with complete science package.

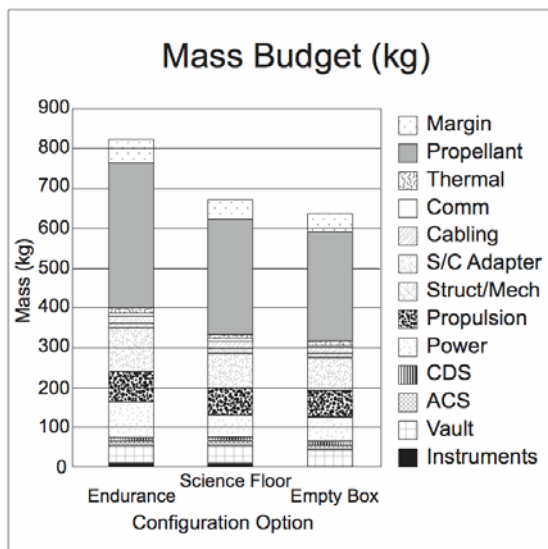

Fig. 9. Mass budget for Endurance lander with complete science package, lander with science floor option, and lander with no sensors to support the science package. None of the options met the 500 kg requirement.

7. CONCLUSIONS

Exploration of the Jovian system, including Jupiter and Europa, is a high priority science goal, which also presents significant technological difficulties.

The extreme environment of Europa can be characterized by high radiation and low temperatures. These must be mitigated. The

proposed Europa Geophysical Explorer mission was identified in [5] as the highest priority first decade flagship mission. This orbiter could also include a small lander to provide in-situ validation of remote sensing measurements.

Previous assessments assumed 375 to 500 kg mass allocation for add-on Europa landers. The present study resulted in a lander mass allocation requirement of ~640 to ~820 kg. However, the current study had limited scope and resources, thus the design was not optimized.

It is recommended to carry out follow-on studies to refine the findings and to optimize the design.

8. ACKNOWLEDGEMENTS

Funding for the NASA/JPL Planetary Science Summer School was provided by the NASA Science Mission Directorate. We would like to thank the following individuals and groups for their help and hard work in making the Planetary Science Summer School such a rewarding experience for all of us: Anita Sohus (Task Manager), Corinne Karpinski (Coordinator and Escort), James Harrington (Goddard Space Flight Center/Mu-SPIN Program), Daniel Sedlacko (Webmaster and Escort), Jean Clough (Escort), Kay Ferrari (Solar System Ambassador Program), JPL Team X (Robert Carnright, Adrian Downs, Luke Dubord, Michael Ethers, Gerardo Flores, Gani Ganapathi, Robert Haw, David Hansen, Cate Heneghan, Robert Kinsey, Gerhard Klose, Masashi Mizukami, David Mulier, Mark Schwochert, Abhijit Sengupta, Parthasar Shakkottai, William Smythe, Christopher Swan, Farinaz Tehrani, Yuwen Tung, Keith Warfield, and Daniel Winterhalter), and our reviewers (James Cutts, Celeste Satter, David Senske, William Smythe, Theodore Sweetser, and Greg Wilson).

9. REFERENCES

1. Greeley, R. and Johnson, T. (2004), *Report of the NASA Science Definition Team for the Jupiter Icy Moons (JIMO)*. Technical Report, National Aeronautics and Space Administration, February 13, 2004.
2. Balint, T. (2004), *Europa Surface Science Package Feasibility Assessment*. 60 p. JPL D-30050, NASA Jet Propulsion Laboratory / California Institute of Technology, Pasadena, CA, September 22, 2004.

3. Prockter, L, Schenk, P (2004), Origin and Evolution of Castalia Macula, An Anomalous Young Depression on Europa, *Eos Trans. AGU*, 85(47), Fall Meet. Suppl., Abstract P31A-0962.
4. Figueredo, P. H., Greeley, R., Neuer, S., Irwin, L., and Schulze-Makuch, D. (2003), Locating Potential Biosignatures on Europa from Surface Geology Observations, *Astrobiology*, vol 3, pp 851-861.
5. NASA. *Solar System Exploration*. JPL 400-1077, Office of Space Sciences, National Aeronautics and Space Administration, Jet Propulsion Laboratory / California Institute of Technology, Pasadena, CA, 2003.