

# HARDWARE REFERENCE MANUAL

## TURBO PMAC2 VME ULTRALITE

Programmable Multi-Axis Controller

4Ax-603616-xHxx

July 16 2003



**DELTA TAU**  
Data Systems, Inc.

*NEW IDEAS IN MOTION ...*

*Single Source Machine Control*

*Power // Flexibility // Ease of Use*

*21314 Lassen Street Chatsworth, CA 91311 // Tel. (818) 998-2095 Fax. (818) 998-7807 // [www.deltatau.com](http://www.deltatau.com)*

## **Copyright Information**

© 2003 Delta Tau Data Systems, Inc. All rights reserved.

This document is furnished for the customers of Delta Tau Data Systems, Inc. Other uses are unauthorized without written permission of Delta Tau Data Systems, Inc. Information contained in this manual may be updated from time-to-time due to product improvements, etc., and may not conform in every respect to former issues.

To report errors or inconsistencies, call or email:

### **Delta Tau Data Systems, Inc. Technical Support**

Phone: (818) 717-5656

Fax: (818) 998-7807

Email: [support@deltatau.com](mailto:support@deltatau.com)

Website: <http://www.deltatau.com>

## **Operating Conditions**

All Delta Tau Data Systems, Inc. motion controller products, accessories, and amplifiers contain static sensitive components that can be damaged by incorrect handling. When installing or handling Delta Tau Data Systems, Inc. products, avoid contact with highly insulated materials. Only qualified personnel should be allowed to handle this equipment.

In the case of industrial applications, we expect our products to be protected from hazardous or conductive materials and/or environments that could cause harm to the controller by damaging components or causing electrical shorts. When our products are used in an industrial environment, install them into an industrial electrical cabinet or industrial PC to protect them from excessive or corrosive moisture, abnormal ambient temperatures, and conductive materials. If Delta Tau Data Systems, Inc. products are exposed to hazardous or conductive materials and/or environments, we cannot guarantee their operation.

# TABLE OF CONTENTS

<b>INTRODUCTION</b> .....	<b>1</b>
Overview.....	1
Board Configuration .....	1
<i>Base Version</i> .....	1
<i>MACRO Ring Connector Options</i> .....	2
<i>Option 1: Additional MACRO Interface Ics</i> .....	2
<i>Option 2: Dual Ported RAM</i> .....	2
<i>Option 5: CPU &amp; Memory Configurations</i> .....	2
<i>Option 7: Plate Mounting</i> .....	3
<i>Option 8: High-Accuracy Clock Crystal</i> .....	3
<i>Option 9: Auxiliary Serial Port</i> .....	3
<i>Option 10: Firmware Version Specification</i> .....	4
<i>Option 16A: Battery-Backed Parameter Memory</i> .....	4
<i>Option 18A: Electronic Identification</i> .....	4
<b>JUMPER DESCRIPTION</b> .....	<b>5</b>
E0: Reset Lock Enable.....	6
E1: Card 0 (Clock Direction) Select .....	6
E2: 40/60 MHz Operation.....	6
E3: Re-Initialization on Reset Control.....	6
E4-E6: (Reserved for Future Use) .....	6
E10A, B, C: Flash Memory Bank Select .....	6
E17 – E18: Serial Port Select.....	7
E19: Watchdog Disable Jumper.....	7
E20 – E22: Power-Up/Reset Load Source.....	8
E23: Firmware Reload Enable .....	8
E40: Electrical/Optical MACRO Input Select .....	8
<b>SOFTWARE SETUP</b> .....	<b>9</b>
PMAC I-Variables: .....	9
<b>MATING CONNECTORS</b> .....	<b>11</b>
<i>J1: JTAG/OnCE (for factory use only): 10-pin IDC header</i> .....	11
<i>J2 (JTHW)/MULTIPLEXER PORT</i> .....	11

<i>J3 (JIO)/DIGITAL I/O</i> .....	11
<i>J5 (JRS232)/RS-232 SERIAL COMMUNICATIONS</i> .....	11
<i>J5A (JRS422)/RS-422 SERIAL COMMUNICATIONS</i> .....	11
<i>J6 (JDISP)/DISPLAY</i> .....	11
<i>J7 (JHW)/AUXILIARY CHANNEL</i> .....	12
<i>J9: JISP (for factory use only): 8-pin SIP connector</i> .....	12
<i>J11 (JEXP)/EXPANSION</i> .....	12
<i>J14: MACRO Electrical Input Connector: 8-pin RJ-45 socket</i> .....	12
<i>J17: MACRO Electrical Output Connector: 8-pin RJ-45 socket</i> .....	12
<i>P1: VME Bus 3U Connector</i> .....	12
<i>P2: VME Bus 3U Connector</i> .....	12
<i>TB1: JPWR Power Supply Connector: 2-point terminal block</i> .....	12
<i>TB2: WD Watchdog Output Connector: 4-point terminal block</i> .....	12
<i>U4: MACRO Fiber Optic Transceiver: Double SC fiber-optic socket</i> .....	12
<b>CONNECTOR PINOUTS</b> .....	<b>13</b>
<i>J2 (JTHW) Multiplexer Port Connector</i> .....	13
<i>J3 (JI/O) General Input/Output Connector</i> .....	14
<i>J5 (JRS232) Serial Port Connector</i> .....	15
<i>J5A: RS422 Serial Port Connector</i> .....	16
<i>J6 (JDISP) Display Connector</i> .....	17
<i>J7 (JHW) Handwheel Encoder Connector</i> .....	18
<i>TB1 (2/4-Pin Terminal Block)</i> .....	19
<i>TB2 (4-Pin Terminal Block)</i> .....	19
<i>MACRO Interface Connectors</i> .....	20
<i>Option A: Fiber Optic Transceiver</i> .....	20
<i>Option C: RJ-45 "Phone Jack" Connectors</i> .....	20
<b>SCHEMATICS</b>	

## INTRODUCTION

---

### Overview

---

The Turbo PMAC2 VME Ultralite is a member of the Turbo PMAC family of boards optimized for interface to the system through the MACRO ring, and therefore does not contain on-board axis interface circuitry (which is what makes it “Ultralite”). It can command up to 32 axes through the MACRO ring. It can also support up to 32 channels of off-board axis interface circuitry through its expansion port, connected to ACC-24P or ACC-24P2 boards.

The Turbo PMAC2 VME Ultralite is a VME-bus card. This card is capable of VME bus communications, with or without the optional dual-ported RAM. Standalone operation is also possible and communications can be done through RS-232 or RS-422.

### Board Configuration

---

#### Base Version

The base version of the Turbo PMAC2 VME Ultralite provides –

- 80 MHz DSP56303 CPU (120 MHz PMAC equivalent)
- 128k x 24 SRAM compiled/assembled program memory (5C0)
- 128k x 24 SRAM user data memory (5C0)
- 1M x 8 flash memory for user backup & firmware (5C0)
- Latest released firmware version
- RS-232/422 serial interface, PCI bus interface
- 1 16-node MACRO interface IC
- MACRO ring circuitry (without connectors; see Opts. A & C)
- (No on-board axis interface circuitry)
- 2 channels supplemental interface circuitry, each including:
  - 2-channel differential/single-ended encoder input
  - 1 output command signal set, configurable as pulse-&-direction or PWM top-and-bottom pair
  - Display, MACRO, muxed I/O, direct I/O interface ports
  - PID/notch/feedforward servo algorithms
  - Extended "pole-placement" servo algorithms
  - 1-year warranty from date of shipment
  - One manual per set of 1 to 4 PMACs in shipment
  - (Cables, mounting plates, mating connectors not included)

## MACRO Ring Connector Options

If a MACRO interface is desired (which is the usual reason for use of the board), at least one of the MACRO connector options must be selected.

- Option A provides the MACRO-ring fiber optic SC-style interface connector. The key component on the board is U4.
- Option C provides the MACRO-ring RJ-45 electrical interface connectors. The key components on the board are J14 and J17.

## Option 1: Additional MACRO Interface Ics

The basic board has one MACRO interface IC and space for three more. Variations of Option 1 fill these spaces as follows:

- **Option 1A** provides the first additional MACRO interface IC (2 total) for 16 additional MACRO nodes, 8 additional servo nodes and 8 additional I/O nodes (32 nodes total, 16 servo and 16 I/O). The key component on the board is U23.
- **Option 1B** provides the second additional MACRO interface IC (3 total) for 16 additional MACRO nodes, 8 additional servo nodes and 8 additional I/O nodes (48 nodes total, 24 servo and 24 I/O). The key component on the board is U24. Option 1A is a pre-requisite.
- **Option 1C** provides the third additional MACRO interface IC (4 total) for 16 additional MACRO nodes, 8 additional servo nodes and 8 additional I/O nodes (64 nodes total, 32 servo and 32 I/O). The key component on the board is U25. Options 1A and 1B are pre-requisites.

## Option 2: Dual Ported RAM

Dual-ported RAM provides a very high-speed communications path for bus communications with the host computer through a bank of shared memory. DPRAM is advised if more than about 100 data items per second are to be passed between the controller and the host computer in either direction. Option 2 provides a 32k x 16 bank of dual-ported RAM. The key component on the board is U191.

## Option 5: CPU & Memory Configurations

The various versions of Option 5 provide different CPU speeds and main memory sizes. Only one Option 5xx may be selected for the board.

The CPU is a DSP563xx IC as component U56. The CPU is available in several speed options: 80 MHz CPU is a DSP56303 (Option 5Cx), 100 MHz CPU is a DSP56309 (Option 5Dx), and 160 MHz CPU is a DSP56311 (Option 5Ex). The maximum frequency of operation is indicated with a sticker on the CPU in U56.

The compiled/assembled-program memory SRAM ICs are located in U40, U43, and U47. These ICs form the active memory for the firmware, compiled PLCs, and user-written phase/servo algorithms. These can be 128k x 8 ICs (for a 128k x 24 bank), fitting in the smaller footprint, or they can be the larger 512k x 8 ICs (for a 512k x 24 bank), fitting in the full footprint.

The user-data memory SRAM ICs are located in U39, U42, and U46. These ICs form the active memory for user motion programs, uncompiled PLC programs, and user tables and buffers. These can be 128k x 8 ICs (for a 128k x 24 bank), fitting in the smaller footprint, or they can be the larger 512k x 8 ICs (for a 512k x 24 bank), fitting in the full footprint.

The flash memory IC is located in U45. This IC forms the non-volatile memory for the board's firmware, the user setup variables, and for user programs, tables, and buffers. It can be 1M x 8, 2M x 8, or 4M x 8 in capacity.

- **OPT-5C0:** Default CPU speed and memory configuration: 80MHz DSP56303 CPU (8Kx24 internal memory), 128Kx24 SRAM compiled/assembled program memory, 128Kx24 SRAM user data memory, 1Mx8 flash memory.
- **OPT-5C3:** 80MHz DSP56303 CPU (8Kx24 internal memory), expanded 512Kx24 SRAM compiled/assembled program memory, expanded 512Kx24 RAM user data memory, 4Mx8 flash memory.
- **OPT-5D0:** 100MHz DSP56309 CPU (34Kx24 internal memory), 128Kx24 SRAM compiled/assembled program memory, 128Kx24 SRAM user data memory, 1Mx8 flash memory.
- **OPT-5D3:** 100MHz DSP56309 CPU (34Kx24 internal memory), expanded 512Kx24 SRAM compiled/assembled program memory, expanded 512Kx24 SRAM user data memory, 4Mx8 flash memory.
- **OPT-5E0:** 160MHz DSP56311 CPU (128Kx24 internal memory), 128Kx24 SRAM compiled/assembled program memory, 128Kx24 SRAM user data memory, 1Mx8 flash memory.
- **OPT-5E3:** 160MHz DSP56311 CPU (128Kx24 internal memory), expanded 512Kx24 SRAM compiled/assembled program memory, expanded 512Kx24 SRAM user data memory, 4Mx8 flash memory.

### **Option 7: Plate Mounting**

Option 7 provides a mounting plate connected to the PMAC with standoffs. It is used to install the PMAC in standalone applications.

### **Option 8: High-Accuracy Clock Crystal**

The Turbo PMAC2 VME Ultralite has a clock crystal (component Y5 of nominal frequency 19.6608 MHz (~20 MHz). The standard crystal's accuracy specification is +/-100 ppm. Option 8A provides a nominal 19.6608 MHz crystal with a +/-15 ppm accuracy specification.

### **Option 9: Auxiliary Serial Port**

The Turbo PMAC2 VME Ultralite comes standard with a single serial port, configurable as RS-232 or RS-422. Optionally a second serial port can be added. Option 9T adds an auxiliary RS-232 port in the CPU section.

### **Option 10: Firmware Version Specification**

Normally the Turbo PMAC2 VME Ultralite is provided with the newest released firmware version. A label on the U45 flash memory IC shows the firmware version loaded at the factory. Option 10 provides for a user-specified firmware version.

### **Option 16A: Battery-Backed Parameter Memory**

The contents of the standard memory are not retained through a power-down or reset unless they have been saved to flash memory first. Option 16A provides a 32k x 24 bank of battery-backed parameter RAM in components U41, U44, and U48 for real-time parameter storage. This is ideal for holding machine state parameters in case of an unexpected power-down. The battery is located at component BT1.

### **Option 18A: Electronic Identification**

Option 18A provides a module at location U67 that contains an electronic identification feature.



# JUMPER DESCRIPTION

The drawing below is a road map to the E-Point locations shown in the tables following.

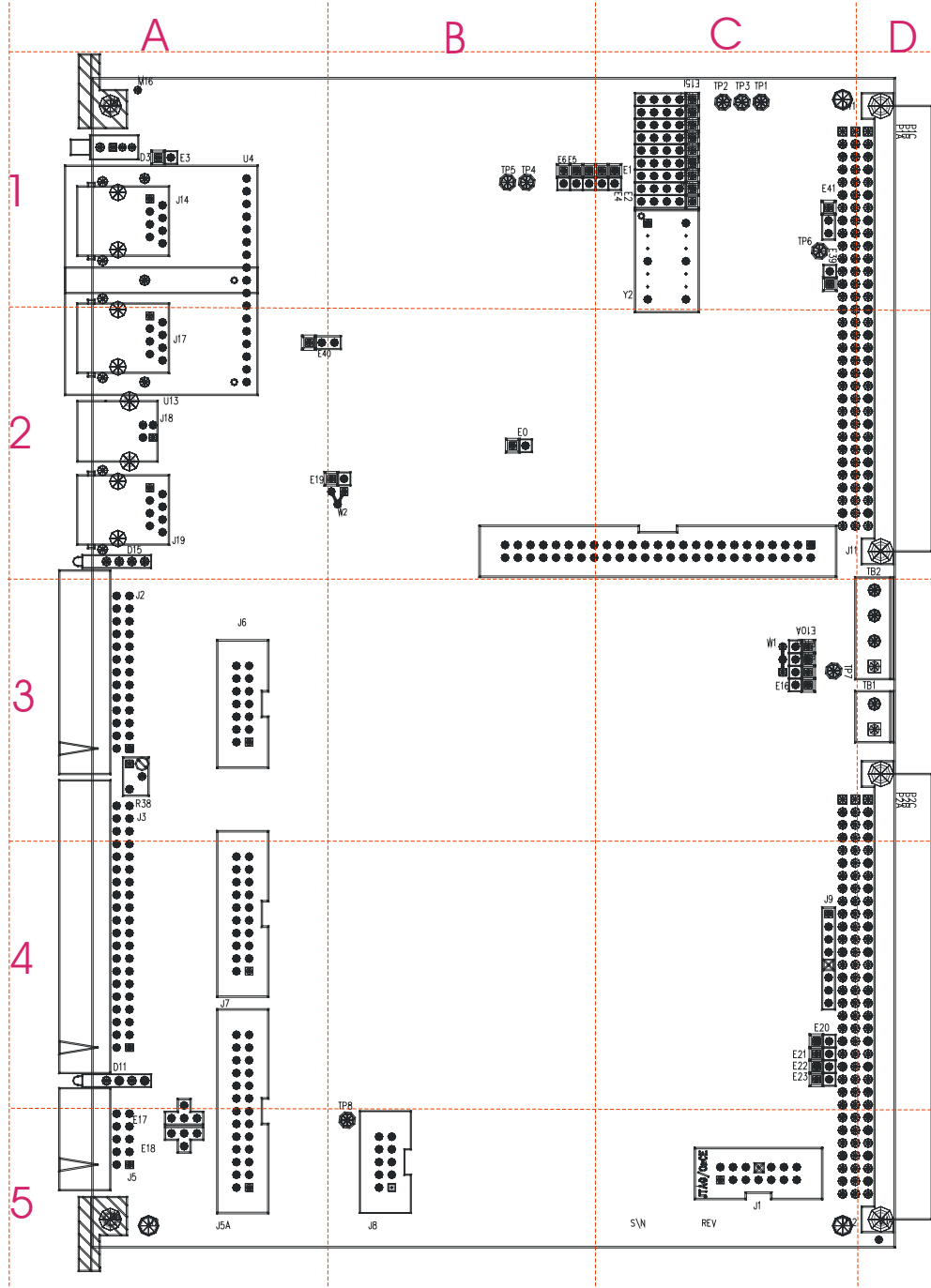

**E0: Reset Lock Enable**

E Point & Physical Layout	Location	Description	Default
<b>E0</b> 	B-2	Remove jumper for normal operation. Jump pins 1 to 2 to force the card to stay in the “reset” state.	No jumper installed

**E1: Card 0 (Clock Direction) Select**

E Point & Physical Layout	Location	Description	Default
<b>E1</b> 	C-1	Remove jumper to specify that this PMAC is Card 0, which generates its own phase and servo clock (default). Jump pins 1 to 2 to specify that this PMAC is not Card 0, but Card 1 to F (15), which requires external phase and servo clock signals from the serial port to operate.	No jumper installed

**E2: 40/60 MHz Operation**

E Point & Physical Layout	Location	Description	Default
<b>E2</b> 	C-1	Remove jumper for 40MHz operation. Jump pins 1 to 2 for 60MHz operation.	No jumper installed

**E3: Re-Initialization on Reset Control**

E Point & Physical Layout	Location	Description	Default
<b>E3</b> 	A-1	Remove jumper for normal reset mode (default). Jump pins 1 to 2 for re-initialization on reset.	No jumper installed

**E4-E6: (Reserved for Future Use)****E10A, B, C: Flash Memory Bank Select**

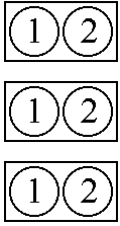
E Point & Physical Layout	Location	Description	Default
<p><b>E10A</b></p>  <p><b>E10C</b></p>	C-3	<p>Remove all 3 jumpers to select flash memory bank with factory-installed firmware.</p> <p>Use other configuration to select one of the 7 other flash memory banks.</p>	No jumpers installed

### E17 – E18: Serial Port Select

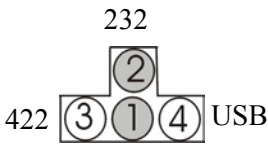
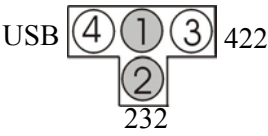
E Point & Physical Layout	Location	Description	Default
<p><b>E17</b></p> 	A-5	<p>Jump E17 pin 1 to 2 to select RS-232 serial data input from J5.</p> <p>Jump E17 pin 1 to 3 to select RS-422 serial data input from J5A.</p> <p>Jump E17 pin 1 to 4 for future use of USB.</p>	Pins 1 – 2 jumpered
<p><b>E18</b></p> 	A-5	<p>Jump E18 pin 1 to 2 to select RS-232 serial handshake input from J5.</p> <p>Jump E18 pin 1 to 3 to select RS-422 serial handshake input from J5A.</p> <p>Jump E18 pin 1 to 4 for future use of USB.</p>	Pins 1 – 2 jumpered

### E19: Watchdog Disable Jumper

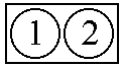
E Point & Physical Layout	Location	Description	Default
<p><b>E19</b></p> 	B-2	<p>Jump pin 1 to 2 to disable WATCHDOG timer (for test purposes only!).</p> <p>Remove jumper to enable WATCHDOG timer.</p>	No jumper installed

## E20 – E22: Power-Up/Reset Load Source

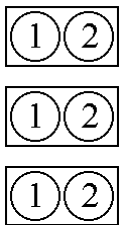
E Point & Physical Layout	Location	Description	Default
<p><b>E20</b></p>  <p><b>E22</b></p>	C-4	<p>Remove jumper E20.</p> <p>Jump E21 pin 1 to 2.</p> <p>Jump E22 pin 2 to 3 to read flash IC on power-up/reset.</p> <p>Other combinations are for factory use only; the board will not operate in any other configuration.</p>	<p>No E20 jumper installed;</p> <p>E21 and E22 jump pin 1 to 2</p>

## E23: Firmware Reload Enable

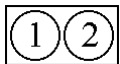
E Point & Physical Layout	Location	Description	Default
<p><b>E23</b></p> 	C-4	<p>Jump pin 1 to 2 to reload firmware through serial or bus port.</p> <p>Remove jumper for normal operation.</p>	No jumper installed

## E40: Electrical/Optical MACRO Input Select

E Point & Physical Layout	Location	Description	Default
<p><b>E16</b></p> 	A-2	<p>Jump E16 pin 1 to 2 to select MACRO input from fiber optic receiver.</p> <p>Remove E16 jumper to select MACRO input from electrical RJ45 receiver.</p>	<p>Jumper installed (Option A)</p> <p>No jumper installed (Option C)</p>

## **SOFTWARE SETUP**

---

### **PMAC I-Variables:**

---

PMAC has a large set of Initialization parameters (I-variables) that determine the "personality" of the card for a specific application. Many of these are used to configure a motor properly. Once set up, these variables may be stored in non-volatile EAROM memory (using the SAVE command) so the card is always configured properly (PMAC loads the EAROM I-variable values into RAM on power-up).

The easiest way to program, setup and troubleshoot PMAC is by using the PMAC Executive Program PEWIN32 and its related add-on packages TurboSetup32 and PMACPlot32. These software packages are available from Delta Tau, ordered through the ACC-9WN accessory. The programming features and configuration variables for the PMAC-VME are fully described in the PMAC User's and Software manuals.



## **MATING CONNECTORS**

---

### **J1: JTAG/OnCE (for factory use only): 10-pin IDC header**

#### **J2 (JTHW)/MULTIPLEXER PORT**

1. 26-pin female flat cable connector Delta Tau P/N 014-R00F26-0K0 qty. 2 - T&B Ansley P/N 609-2641
2. 171-26 T&B Ansley stan. flat cable stranded 26-wire
3. Phoenix varioface module type FLKM 26 (male pins) P/N 22 81 05 0

#### **J3 (JIO)/DIGITAL I/O**

1. 40-pin female flat cable connector Delta Tau P/N 014-R00F40-0K0 qty. 2 - T&B Ansley P/N 609-4041
2. 171-40 T&B Ansley stan. flat cable stranded 40-wire
3. Phoenix varioface module type FLKM 40 (male pins)

#### **J5 (JRS232)/RS-232 SERIAL COMMUNICATIONS**

1. 10-pin female flat cable connector Delta Tau P/N 014-ROOF10-0K0 qty. 2 - T&B Ansley P/N 609-1041
2. 171-10 T&B Ansley stan. flat cable stranded 10-wire
3. Phoenix varioface module type FLKM 10 (male pins) P/N 22 81 01 8

#### **J5A (JRS422)/RS-422 SERIAL COMMUNICATIONS**

1. 26-pin female flat cable connector Delta Tau P/N 014-R00F26-0K0 qty. 2 - T&B Ansley P/N 609-2641
2. 171-26 T&B Ansley stan. flat cable stranded 26-wire
3. Phoenix varioface module type FLKM 26 (male pins) P/N 22 81 05 0

#### **J6 (JDISP)/DISPLAY**

1. 14-pin female flat cable connector Delta Tau P/N 014-R00F14-0K0  
Qty. 2 - T&B Ansley P/N 609-1441
2. 171-14 T&B Ansley stan. flat cable stranded 14-wire
3. Phoenix varioface modules type FLKM14 (male pins) P/N 22 81 02 1

**J7 (JHW)/AUXILIARY CHANNEL**

1. 20-pin female flat cable connector Delta Tau P/N 014-R00F20-0K0  
Qty. 2 - T&B Ansley P/N 609-2041
2. 171-20 T&B Ansley stan. flat cable stranded 20-wire
3. Phoenix varioface modules type FLKM20 (male pins)

**J9: JISP (for factory use only): 8-pin SIP connector**

**J11 (JEXP)/EXPANSION**

1. 50-pin female flat cable connector Delta Tau P/N 014-R00F50-0K0 qty. 2 - T&B Ansley P/N 609-5041
2. 171-50 T&B Ansley stan. flat cable stranded 50-wire
3. Phoenix varioface module type FLKM 50 (male pins) P/N 22 81 08 9

**J14: MACRO Electrical Input Connector: 8-pin RJ-45 socket**

**J17: MACRO Electrical Output Connector: 8-pin RJ-45 socket**

**P1: VME Bus 3U Connector**

**P2: VME Bus 3U Connector**

**TB1: JPWR Power Supply Connector: 2-point terminal block**

**TB2: WD Watchdog Output Connector: 4-point terminal block**

**U4: MACRO Fiber Optic Transceiver: Double SC fiber-optic socket**



## CONNECTOR PINOUTS

### J2 (JTHW) Multiplexer Port Connector

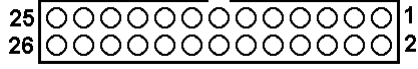
J2/JTHW (26-PIN HEADER)				
Pin #	Symbol	Function	Description	Notes
1	GND	Common	PMAC Common	
2	GND	Common	PMAC Common	
3	DAT0	Input	Data-0 Input	Data input from MUX port accessories
4	SEL0	Output	Select-0 Output	Address data output for MUX port accessories
5	DAT1	Input	Data -1 Input	Data input from MUX port accessories
6	SEL1	Output	Select -1 Output	Address data output for MUX port accessories
7	DAT2	Input	Data -2 Input	Data input from MUX port accessories
8	SEL2	Output	Select -2 Output	Address data output for MUX port accessories
9	DAT3	Input	Data -3 Input	Data input from MUX port accessories
10	SEL3	Output	Select -3 Output	Address data output for MUX port accessories
11	DAT4	Input	Data -4 Input	Data input from MUX port accessories
12	SEL4	Output	Select -4 Output	Address data output for MUX port accessories
13	DAT5	Input	Data -5 Input	Data input from MUX port accessories
14	SEL5	Output	Select -5 Output	Address data output for MUX port accessories
15	DAT6	Input	Data -6 Input	Data input from MUX port accessories
16	SEL6	Output	Select -6 Output	Address data output for MUX port accessories
17	DAT7	Input	Data -7 Input	Data input from MUX port accessories
18	SEL7	Output	Select -7 Output	Address data output for MUX port accessories
19	N.C.	N.C.	No Connection	
20	GND	Common	PMAC Common	
21	BRLD/	Output	Buffer Request	Low is "BUFFER REQ."
22	GND	Common	PMAC Common	
23	IPLD/	Output	In Position	Low is "IN POSITION"
24	GND	Common	PMAC Common	
25	+5V	Output	+5VDC Supply	Power supply out
26	INIT/	Input	PMAC Reset	Low is "RESET"

The JTHW multiplexer port connector provides 8 inputs and 8 outputs at TTL levels; these are typically used to create multiplexed I/O with accessory boards such as ACC-18 (Thumbwheel) and ACC-34 (Discrete I/O). The port I/O may also be used directly, as non-multiplexed I/O.

## J3 (JI/O) General Input/Output Connector

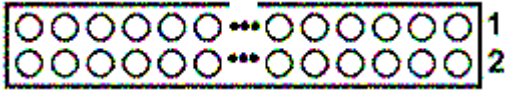
J3/JIO (40-PIN HEADER)				
Pin #	Symbol	Function	Description	Notes
1	I/O00	In/Out	Digital I/O 0	Software Direction Control.
2	I/O01	In/Out	Digital I/O 1	Software Direction Control.
3	I/O02	In/Out	Digital I/O 2	Software Direction Control.
4	I/O03	In/Out	Digital I/O 3	Software Direction Control.
5	I/O04	In/Out	Digital I/O 4	Software Direction Control.
6	I/O05	In/Out	Digital I/O 5	Software Direction Control.
7	I/O06	In/Out	Digital I/O 6	Software Direction Control.
8	I/O07	In/Out	Digital I/O 7	Software Direction Control.
9	I/O08	In/Out	Digital I/O 8	Software Direction Control.
10	I/O09	In/Out	Digital I/O 9	Software Direction Control.
11	I/O10	In/Out	Digital I/O 10	Software Direction Control.
12	I/O11	In/Out	Digital I/O 11	Software Direction Control.
13	I/O12	In/Out	Digital I/O 12	Software Direction Control.
14	I/O13	In/Out	Digital I/O 13	Software Direction Control.
15	I/O14	In/Out	Digital I/O 14	Software Direction Control.
16	I/O15	In/Out	Digital I/O 15	Software Direction Control.
17	I/O16	In/Out	Digital I/O 16	Software Direction Control.
18	I/O17	In/Out	Digital I/O 17	Software Direction Control.
19	I/O18	In/Out	Digital I/O 18	Software Direction Control.
20	I/O19	In/Out	Digital I/O 19	Software Direction Control.
21	I/O20	In/Out	Digital I/O 20	Software Direction Control.
22	I/O21	In/Out	Digital I/O 21	Software Direction Control.
23	I/O22	In/Out	Digital I/O 22	Software Direction Control.
24	I/O23	In/Out	Digital I/O 23	Software Direction Control.
25	I/O24	In/Out	Digital I/O 24	Software Direction Control.
26	I/O25	In/Out	Digital I/O 25	Software Direction Control.
27	I/O26	In/Out	Digital I/O 26	Software Direction Control.
28	I/O27	In/Out	Digital I/O 27	Software Direction Control.
29	I/O28	In/Out	Digital I/O 28	Software Direction Control.
30	I/O29	In/Out	Digital I/O 29	Software Direction Control.
31	I/O30	In/Out	Digital I/O 30	Software Direction Control.
32	I/O31	In/Out	Digital I/O 31	Software Direction Control.
33	GND	common	Reference Voltage	
34	GND	common	Reference Voltage	
35	PHASE/	output	Phase Clock	For latching data
36	SERVO/	output	Servo Clock	For latching data
37	GND	common	Reference Voltage	
38	GND	common	Reference Voltage	
39	+5V	output	Supply Voltage	To power ext. circuitry
40	+5V	output	Supply Voltage	To power ext. circuitry

The JI/O connector provides 32 input/output pins at TTL levels. Direction can be controlled in byte-wide groups.

## J5 (JRS232) Serial Port Connector

J5/JRS232 (10-PIN HEADER)		 Front View		
Pin #	Symbol	Function	Description	Notes
1	PHASE	In/Out	Phasing Clock	See Notes 1, 2
2	DTR	Bidirect	Data Terminal Ready	Tied to "DSR"
3	TXD/	Input	Receive Data	Host transmit data
4	CTS	Input	Clear to Send	Host ready bit
5	RXD/	Output	Send Data	Host receive data
6	RTS	Output	Request to Send	PMAC ready bit
7	DSR	Bidirect	Data Set Ready	Tied to "DTR"
8	SERVO	In/Out	Servo Clock	See Note 2
9	GND	Common	PMAC Common	
10	+5V	Output	+5VDC Supply	Power supply out

The JRS232 connector provides the PMAC2-PC with the ability to communicate serially with an RS232 port. This connector cannot be used for daisychain communication interconnection of multiple PMACs, although it can be used to share servo and phase clocks for synchronicity. The J5A RS-422 interface is required for daisychain communication.

Jumpers E17 and E18 must connect pins 1 and 2 to use this port for serial communications.

**Note 1:** If communicating to PMAC2 over this connector with a "modem" style terminal emulator such as Microsoft Windows Terminal, line 1 should not be connected.

**Note 2:** SERVO and PHASE are outputs if jumper E1 is OFF; they are inputs if jumper E1 is ON.

## J5A: RS422 Serial Port Connector

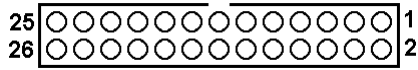
J5A/JRS422 (26-PIN HEADER)			 Front View	
Pin #	Symbol	Function	Description	Notes
1	CHASSI	Common	PMAC Common	
2	S+5V	Output	+5VDC Supply	Deactivated by "E8"
3	RD-	Input	Receive Data	Diff. I/O low TRUE **
4	RD+	Input	Receive Data	Diff. I/O high TRUE *
5	SD-	Output	Send Data	Diff. I/O low TRUE **
6	SD+	Output	Send Data	Diff. I/O high TRUE *
7	CS+	Input	Clear to Send	Diff. I/O high TRUE **
8	CS-	Input	Clear to Send	Diff. I/O low TRUE *
9	RS+	Output	Request to Send	Diff. I/O high TRUE **
10	RS-	Output	Request to Send	Diff. I/O low TRUE *
11	DTR	Bidirect	Data Terminal Ready	TIED TO "DSR"
12	INIT/	Input	PMAC Reset	Low is "RESET"
13	GND	Common	PMAC Common	**
14	DSR	Bidirect	Data Set Ready	TIED TO "DTR"
15	SDIO-	Bidirect	Special Data	Diff. I/O low TRUE
16	SDIO+	Bidirect	Special Data	Diff. I/O high TRUE
17	SCIO-	Bidirect	Special Control	Diff. I/O low TRUE
18	SCIO+	Bidirect	Special Control	Diff. I/O high TRUE
19	SCK-	Bidirect	Special Clock	Diff. I/O low TRUE
20	SCK+	Bidirect	Special Clock	Diff. I/O high TRUE
21	SERVO-	Bidirect	Servo Clock	Diff. I/O low TRUE ***
22	SERVO+	Bidirect	Servo Clock	Diff. I/O high TRUE ***
23	PHASE-	Bidirect	Phase Clock	Diff. I/O low TRUE ***
24	PHASE+	Bidirect	Phase Clock	Diff. I/O high TRUE ***
25	GND	Common	PMAC Common	
26	+5V	Output	+5VDC Supply	Power supply out

The JRS422 connector provides the PMAC with the ability to communicate both in RS422 and RS232. In addition, this connector is used to daisychain interconnect multiple PMACs for synchronized operation.

Jumpers E17 and E18 must connect pins 2 and 3 to use this port for serial communications.

## J6 (JDISP) Display Connector

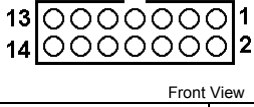
J6/JDISP (14-PIN HEADER)				
Pin #	Symbol	Function	Description	Notes
1	Vdd	Output	+5V Power	Power supply out
2	Vss	Common	PMAC Common	
3	Rs	Output	Read Strobe	TTL signal out
4	Vee	Output	Contrast Adjust Vee	0 TO +5 VDC *
5	E	Output	Display Enable	High is ENABLE
6	R/W	Output	Read or Write	TTL signal out
7	DB1	Output	Display Data1	
8	DB0	Output	Display Data0	
9	DB3	Output	Display Data3	
10	DB2	Output	Display Data2	
11	DB5	Output	Display Data5	
12	DB4	Output	Display Data4	
13	DB7	Output	Display Data7	
14	DB6	Output	Display Data6	

The JDISP connector is used to drive the 2 line x 24 character (Acc-12), 2 x 40 (Acc-12A) LCD, or the 2 x 40 vacuum fluorescent (Acc 12C) display unit. The DISPLAY command may be used to send messages and values to the display.

## J7 (JHW) Handwheel Encoder Connector

<b>J7/JHW (20-PIN HEADER)</b>				
<b>Pin #</b>	<b>Symbol</b>	<b>Function</b>	<b>Description</b>	<b>Notes</b>
1	GND	Common	Reference Voltage	
2	+5V	Output	Supply Voltage	To power ext. circuitry
3	HWA1+	Input	HW Pos A Chan.	Also pulse input
4	HWA1-	Input	HW Neg A Chan.	Also pulse input
5	HWB1+	Input	HW Pos B Chan.	Also direction input
6	HWB1-	Input	HW Neg B Chan.	Also direction input
7	HWA2+	Input	HW Pos A Chan.	Also pulse input
8	HWA2-	Input	HW Neg A Chan.	Also pulse input
9	HWB2+	Input	HW Pos B Chan.	Also direction input
10	HWB2-	Input	hw Neg B Chan.	Also direction input
11	PUL1+	Output	PFM Pos Pulse	Also PFM output
12	PUL1-	Output	PFM Neg Pulse	Also PFM output
13	DIR1+	Output	PFM Pos Dir. Out	Also PFM output
14	DIR1-	Output	PFM Neg Dir. Out	Also PFM output
15	PUL2+	Output	PFM Pos Pulse	Also PFM output
16	PUL2-	Output	PFM Neg Pulse	Also PFM output
17	DIR2+	Output	PFM Pos Dir. Out	Also PFM output
18	DIR2-	Output	PFM Neg Dir. Out	Also PFM output
19	GND	Common	Reference Voltage	
20	+5V	Output	Supply Voltage	To power ext. circuitry

This connector provides the interface for 2 quadrature encoders, typically to be used as "handwheel" or time base master encoders. It also provides two channels of pulse-and-direction or PWM top-and-bottom pair outputs.

## TB1 (2/4-Pin Terminal Block)

---

Pin #	Symbol	Function	Description	Notes
1	GND	Common	Reference Voltage	
2	+5V	Input	Positive Supply Voltage	Supplies all PMAC digital circuits

This terminal block can be used to provide the input for the power supply for the circuits on the PMAC2 board when it is not in a bus configuration. When the PMAC2 is in a bus configuration, these supplies automatically come through the bus connector from the bus power supply; in this case, this terminal block should not be used.

## TB2 (4-Pin Terminal Block)

---

Pin #	Symbol	Function	Description	Notes
1	WD_NC	Output	Watchdog Relay Out	Normally closed
2	COM	Input	Watchdog Return	+V or 0V
3	WD_NO	Output	Watchdog Relay Out	Normally open
4	COM	Input	Watchdog Return	+V or 0V

This terminal block provides the output for PMAC2's watchdog timer relay, both normally open and normally closed contacts

**Note:** The "normally-closed" relay contact is open while PMAC2 is operating properly -- it has power and the watchdog timer is not tripped -- and closed when the PMAC2 is not operating properly -- either it has lost power or the watchdog timer has tripped. The "normally-open" relay contact is closed while PMAC2 is operating properly, and open when PMAC2 is not operating properly.

## **MACRO Interface Connectors**

---

### **Option A: Fiber Optic Transceiver**

U4 Lower port: Transmit Optical Data

U4 Upper port: Receive Optical Data

### **Option C: RJ-45 "Phone Jack" Connectors**

J14: Receive Data

J17: Transmit Data



THIS DOCUMENT IS THE CONFIDENTIAL PROPERTY OF DELTA TAU DATA SYSTEMS INC. AND IS LOANED SUBJECT TO RETURN UPON DEMAND. TITLE TO THIS DOCUMENT IS NEVER SOLD OR TRANSFERRED FOR ANY REASON. THIS DOCUMENT IS TO BE USED ONLY PURSUANT TO WRITTEN LICENSE OR WRITTEN INSTRUCTIONS OF DELTA TAU DATA SYSTEMS INC. ALL RIGHTS TO DESIGN AND INVENTIONS ARE RESERVED BY DELTA TAU DATA SYSTEMS INC. POSSESSION OF THIS DOCUMENT INDICATES ACCEPTANCE OF THE ABOVE AGREEMENT.

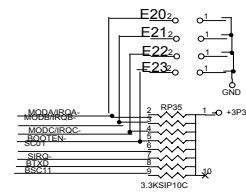
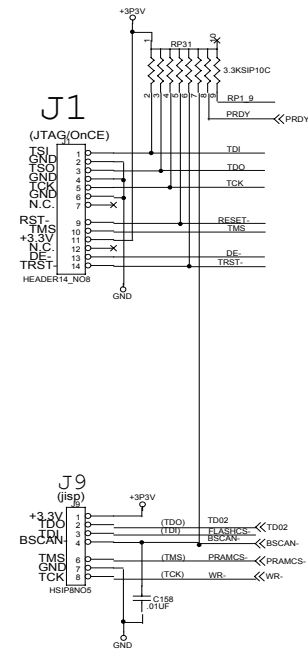

P-8000000-80FFFF  
 XY-8000000-80107FF STANDARD MEMORY OPTION (64K)  
 XY-8000000-803FFFF EXTENDED MEMORY OPTION (448K)

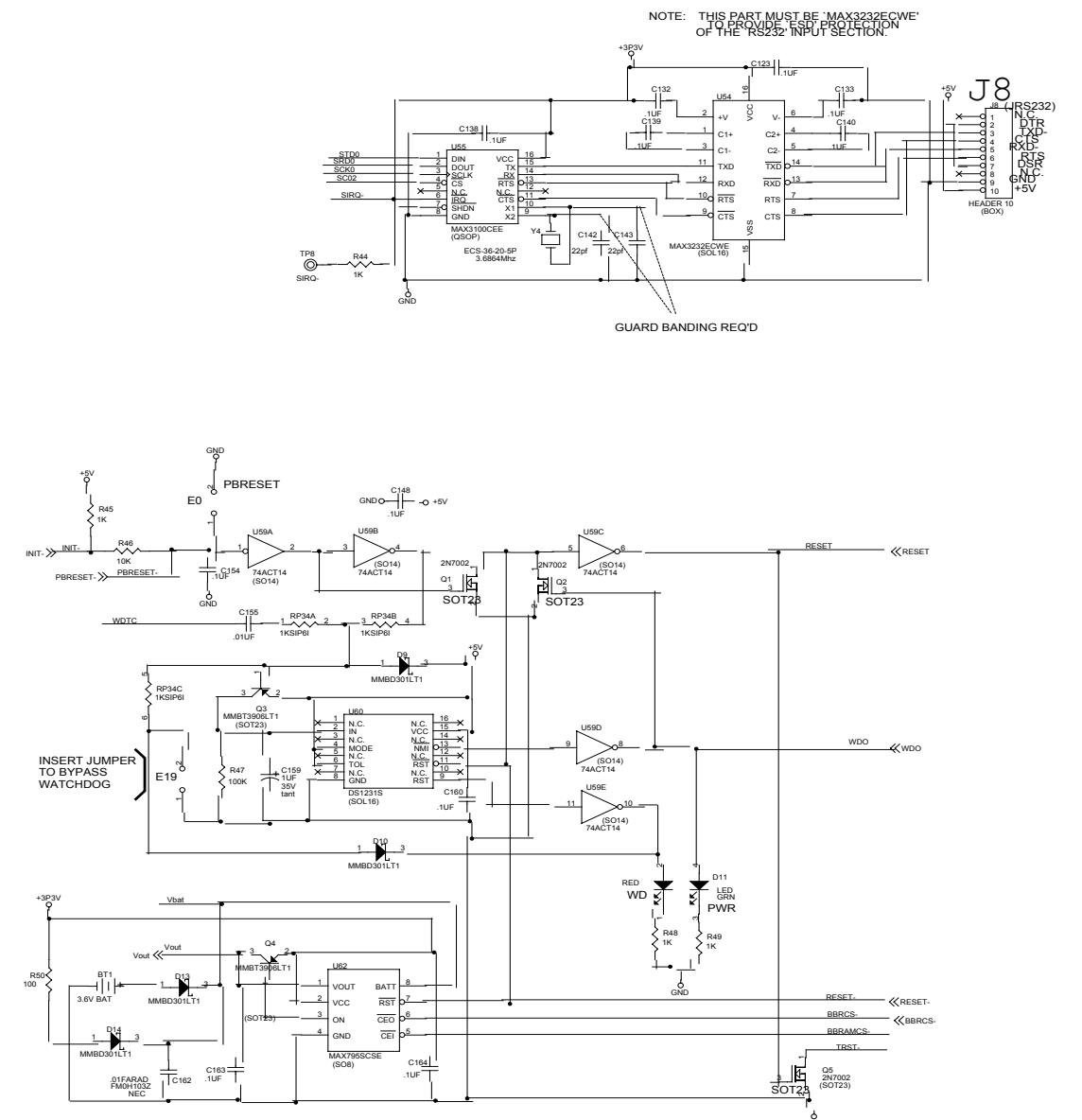
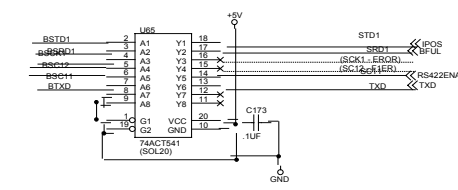
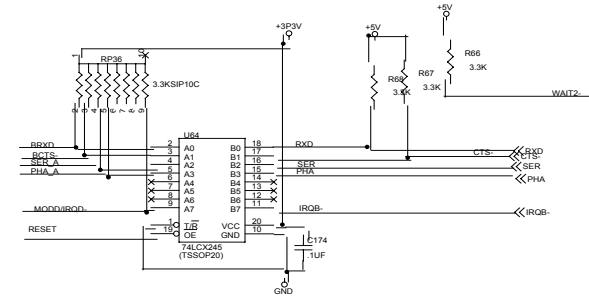
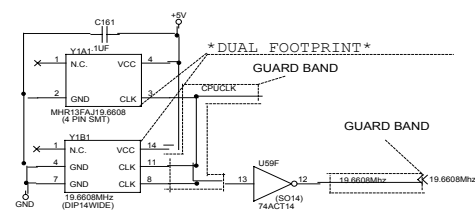

NOTE: THIS PART MUST BE MAX3232CWE TO PROVIDE ESD PROTECTION OF THE RS232 INPUT SECTION.

GUARD BANDING REQ'D

PRAM MEMORY P:  
 \$000000-\$00FFFF Firmware (64K)  
 \$040000-\$0403FF User Written Phase (1K)  
 \$040400-\$040BFF User Written Servo (2K)  
 \$050000-\$05FFFF Plcc Standard Memory Option (64K)  
 \$050000-\$0BFFFF Plcc Extended Memory Option (448K)

(CPU Section)

DELTA TAU DATA SYSTEMS, Inc.	
File	PMAC2-VME FLEX ULTRALITE
Size	Document Number 603616-322
Date	Friday, June 13, 2003 Sheet 1 of 6

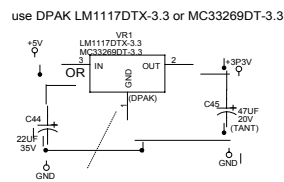
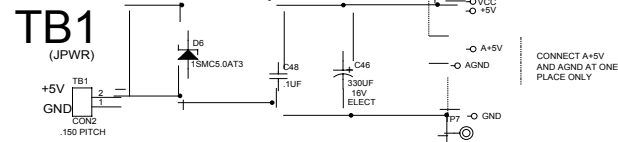

PLACE COPPER FOR CIRCUIT BOARD HEAT SINK

"E10" FLASH BANK SELECT

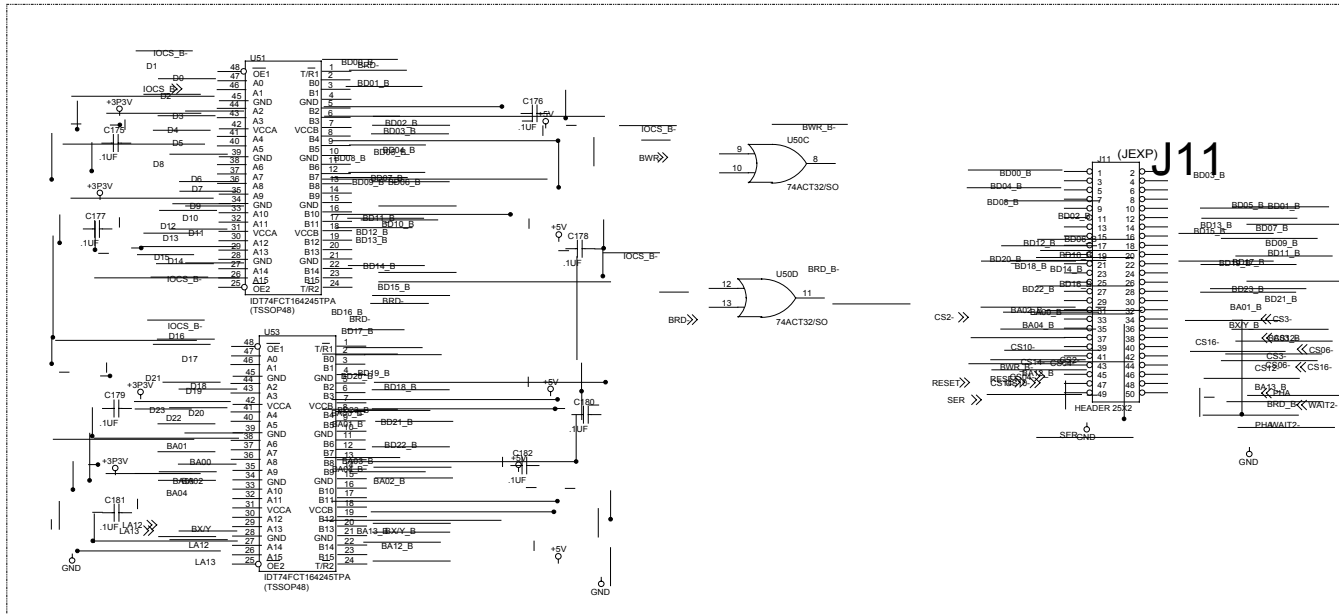
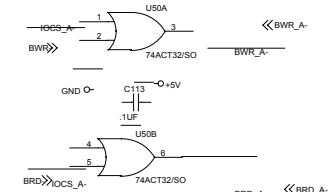
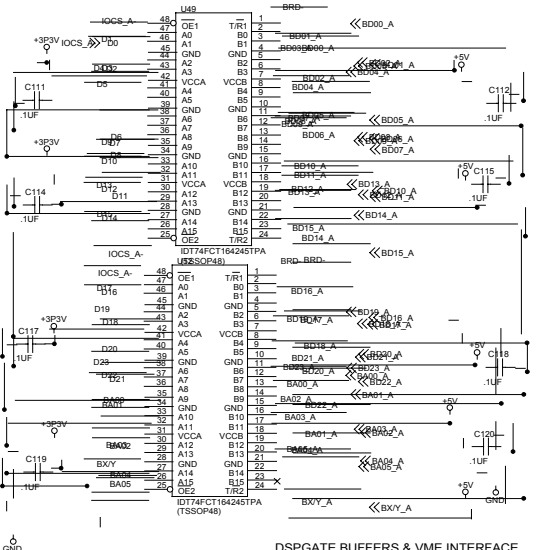
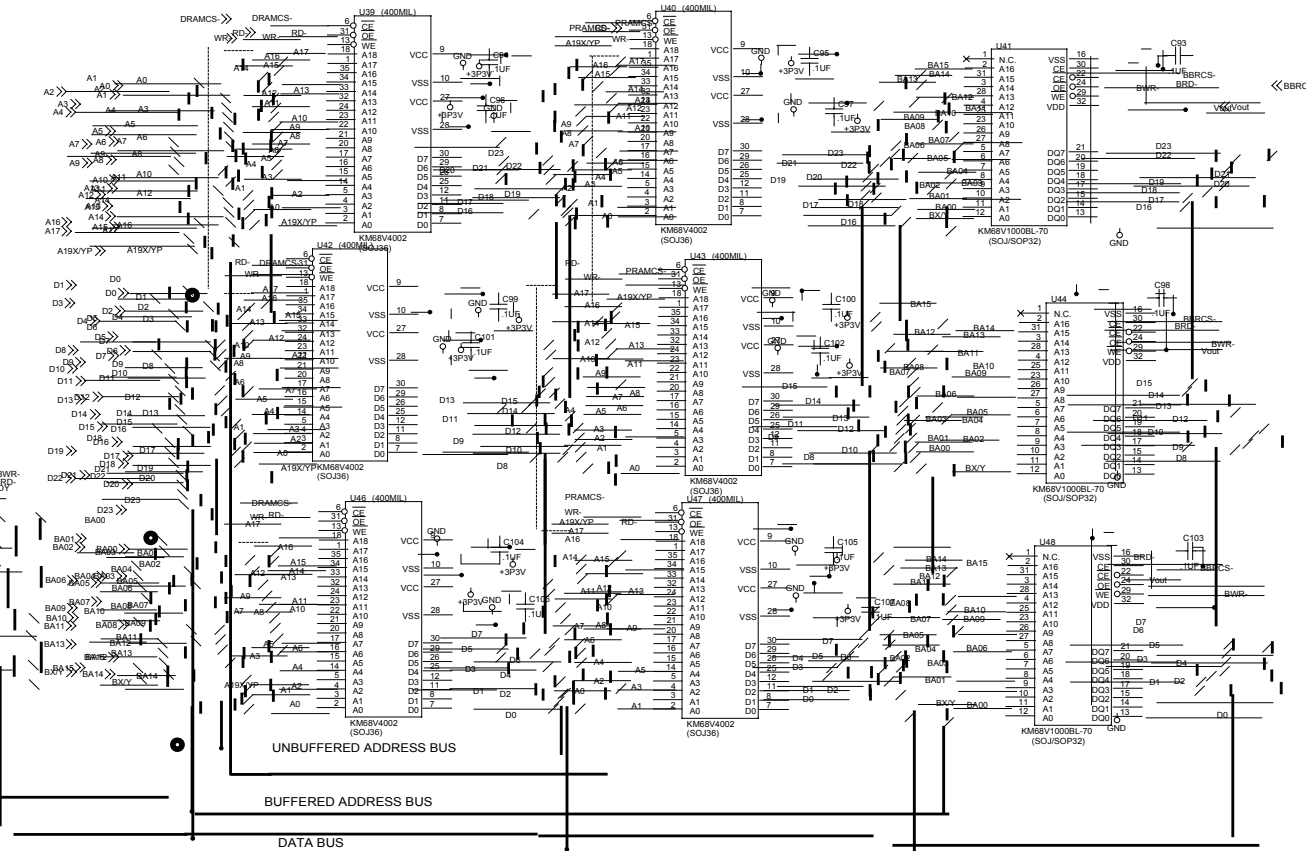
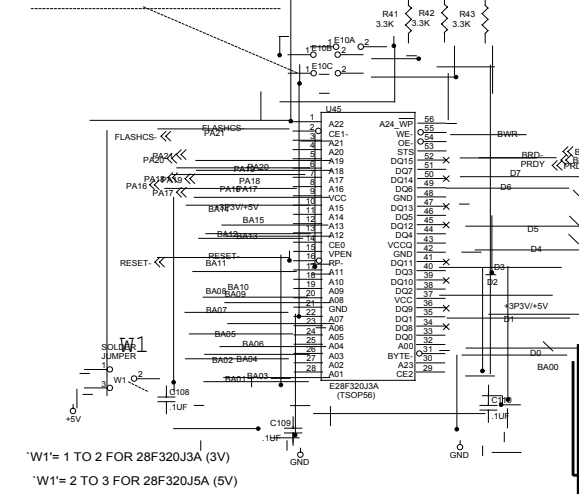

EXPANSION PORT DRIVERS AND CONNECTOR

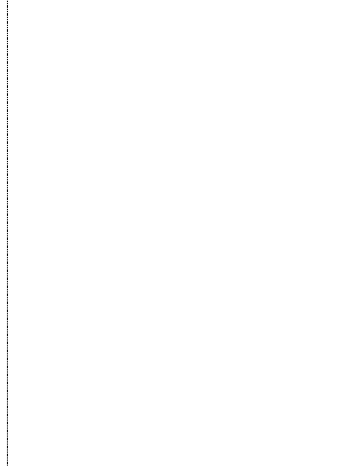

THIS DOCUMENT IS THE CONFIDENTIAL PROPERTY OF DELTA AND DATA SYSTEMS INC. AND IS LOANED UNDER THE "LOAN/LEASE/RENTAL" TITLE TO THIS DOCUMENT IS NEVER SOLD OR TRANSFERRED FOR ANY REASON. THIS DOCUMENT IS TO BE USED ONLY PURSUANT TO THE "LOAN/LEASE/RENTAL" AGREEMENT OF DELTA AND DATA SYSTEMS INC. ALL RIGHTS IN PATENTS AND INVENTIONS ARE RESERVED BY DELTA AND DATA SYSTEMS INC. CONFIDENTIALITY OF THIS DOCUMENT IS ACCEPTED BY THE ABOVE AGREEMENT.

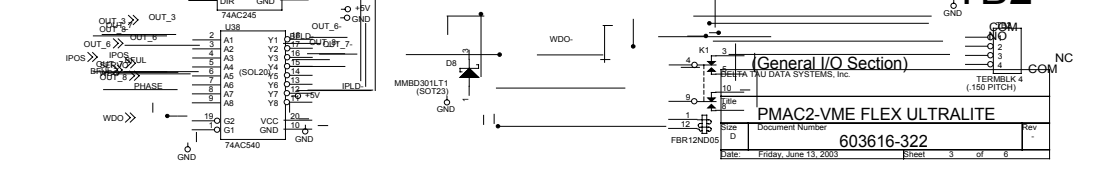
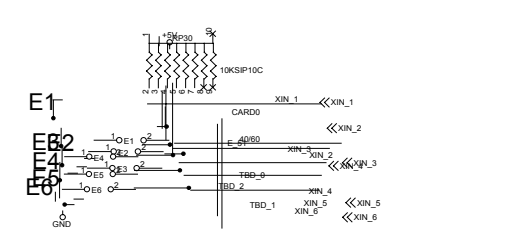
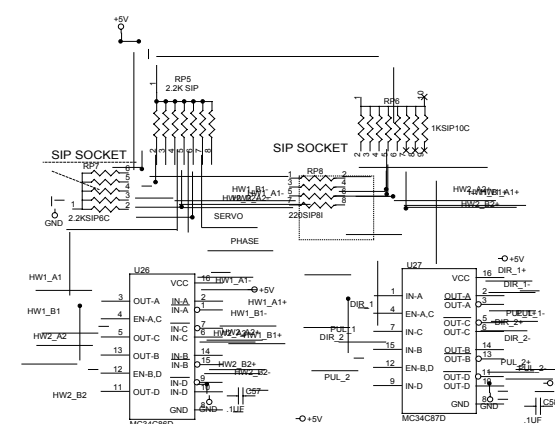
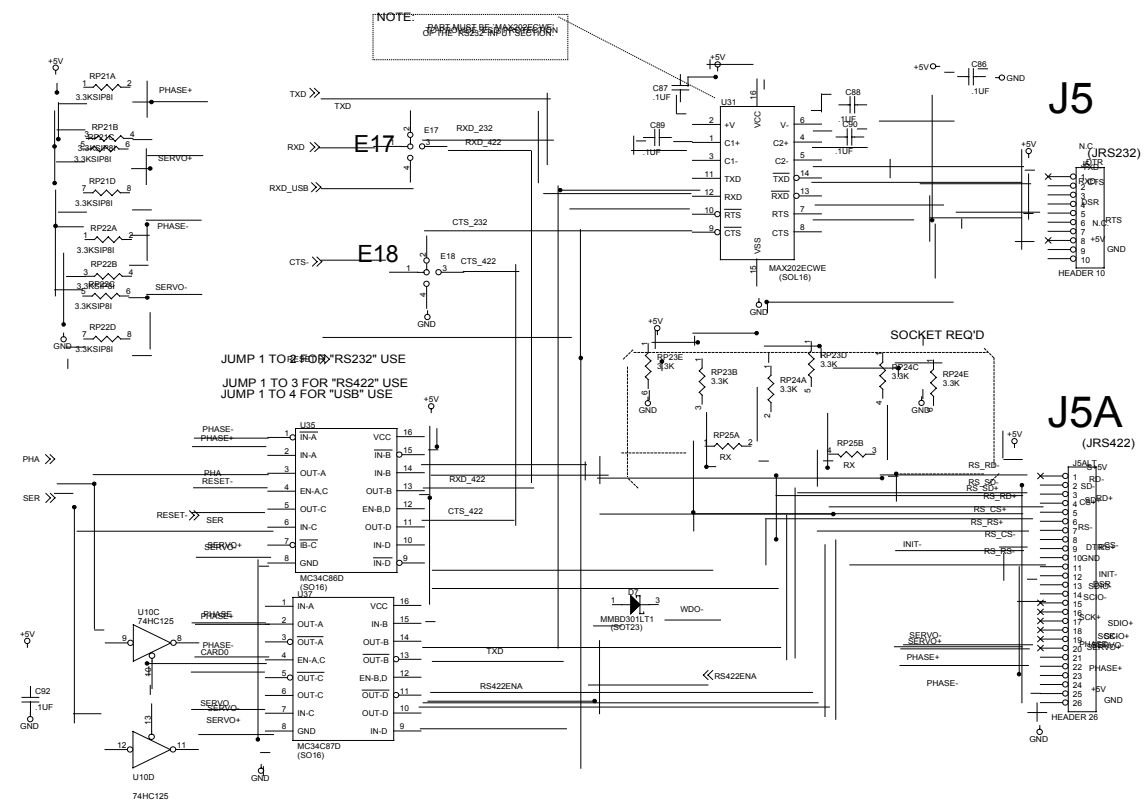
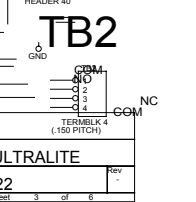
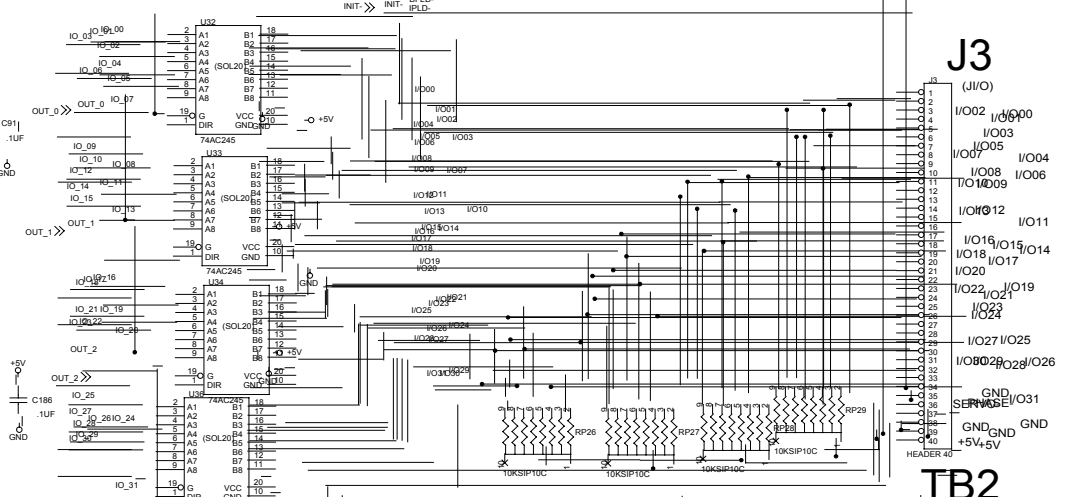
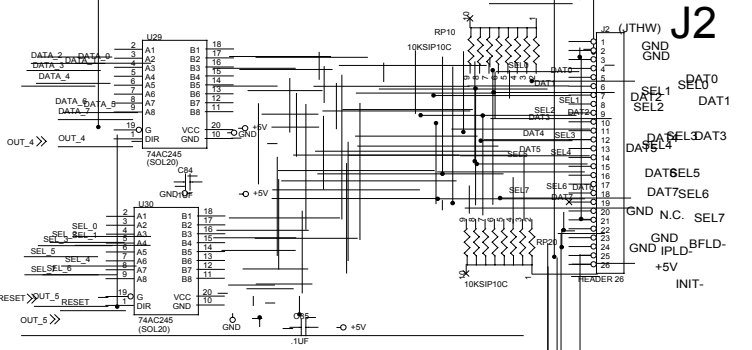
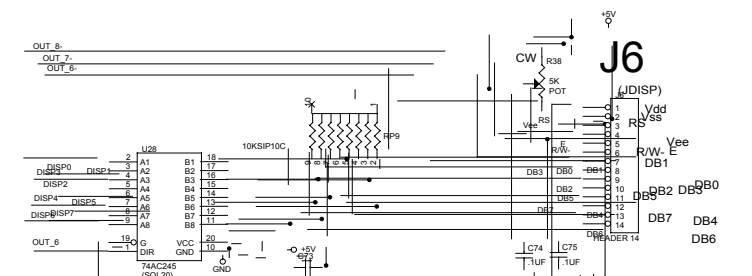
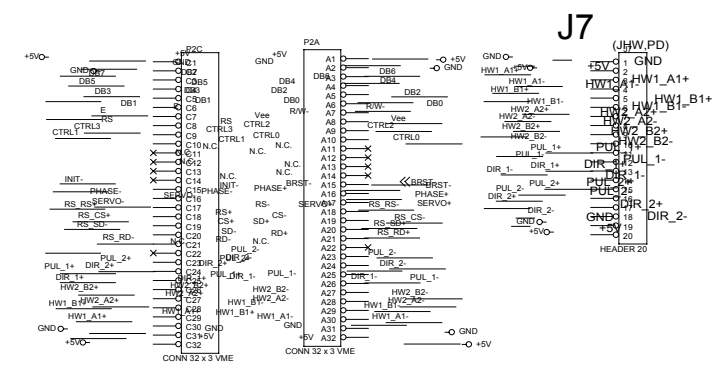
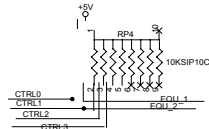

THIS DOCUMENT IS THE CONFIDENTIAL PROPERTY OF DELTA TWO DATA SYSTEMS INC. AND IS LOANED SUBJECT TO RETURN UPON DEMAND. IT IS NOT TO BE REPRODUCED OR TRANSMITTED IN ANY FORM OR BY ANY MEANS, ELECTRONIC OR MECHANICAL, INCLUDING PHOTOCOPYING, RECORDING, OR BY ANY INFORMATION STORAGE AND RETRIEVAL SYSTEM. DELTA TWO DATA SYSTEMS INC. ASSUMES NO LIABILITY FOR THE LOSS OF OR DAMAGE TO ANY INFORMATION STORED IN OR TRANSMITTED BY THIS SYSTEM. DELTA TWO DATA SYSTEMS INC. ASSUMES NO LIABILITY FOR THE LOSS OF OR DAMAGE TO ANY INFORMATION STORED IN OR TRANSMITTED BY THIS SYSTEM.

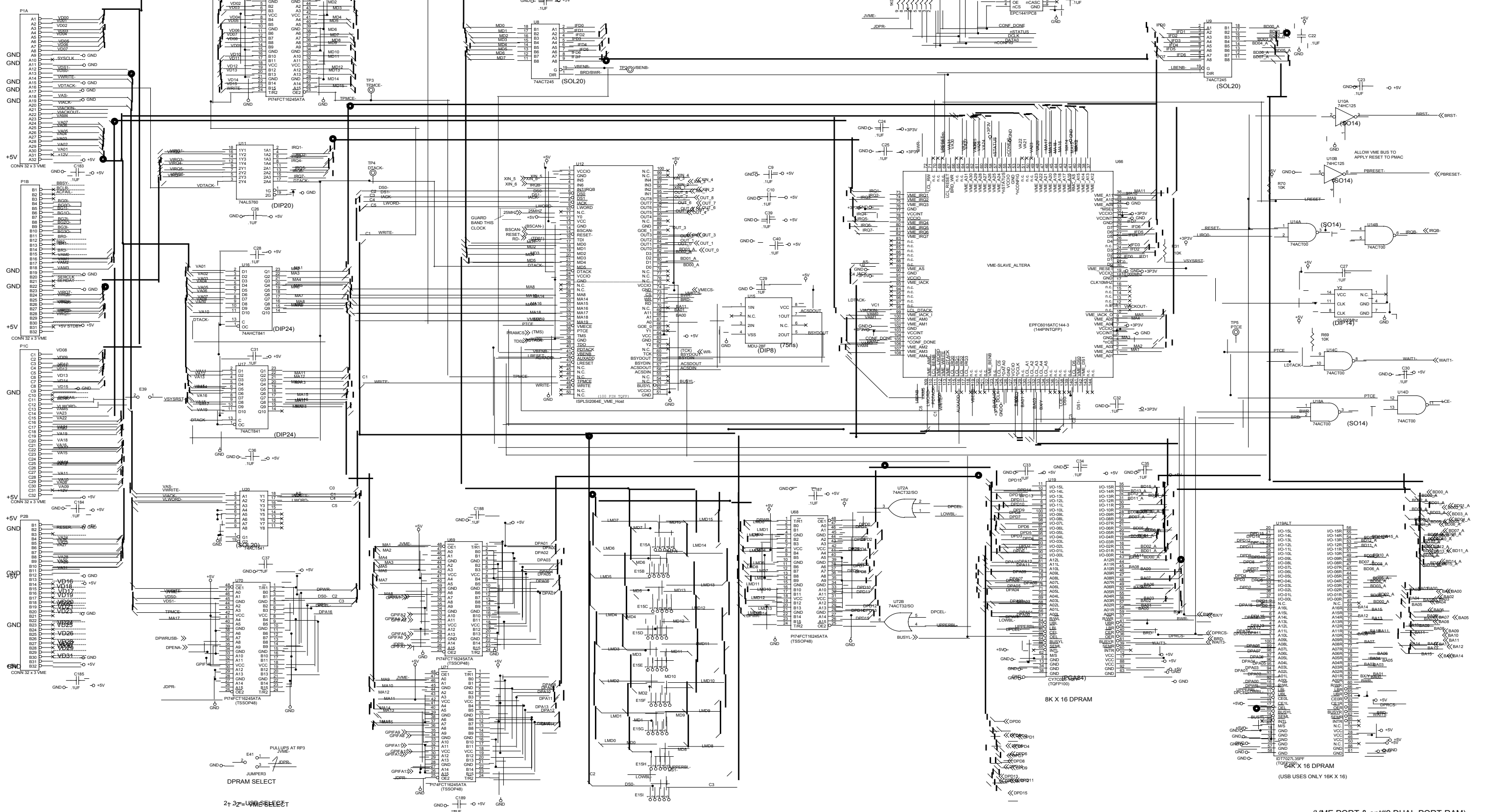

(VME PORT & opt#2 DUAL-PORT-RAM)

REV	603616-322	REV
Doc	Document Number	
Date	Friday, June 13, 2003	Sheet
		4 of 8