

UNITED STATES DEPARTMENT OF LABOR
Mine Safety and Health Administration

**EVALUATION OF AUSTIN ELECTRO*STAR (E*STAR)
ELECTRONIC DETONATOR BLASTING SYSTEM--
REQUIREMENTS FOR
SHUNTING & CIRCUIT TESTING**

PAR 0093501
March 2007

By

Harry Verakis and Dean Nichols

-Originating Office-

**MSHA TECHNICAL SUPPORT
APPROVAL AND CERTIFICATION CENTER**
Industrial Park Road
P. O. Box, Box 251
Triadelphia, West Virginia 26059
(304) 547-0400

TABLE OF CONTENTS

1. Purpose
2. Introduction--Electric Detonators
3. Technical Discussion
4. Mine Field Trials
5. Conclusions
6. Summary

CAPTIONS

- Figure 1 - Electric Detonator Components
- Figure 2 - An Example of Electronic Detonator Components
- Figure 3 - Austin E*Star Electronic Detonator
- Figure 4 - Austin E*Star Electronic Detonator Blasting System
- Figure 5 -- Austin Electro*Star Electronic Detonators with Connector Block
- Figure 6 -- E*Star Electronic Detonator Connected to the Dash 1 Logger
- Figure 7 -- Current Test of an E*Star Electronic Detonator using the Dash 1 Logger
- Figure 8 -- Dash 1 and Dash 100 Loggers
- Figure 9 -- Dash 100 Logger Showing Defective Detonator (Dummy)
- Figure 10 - Check on Depth of Blast Hole
- Figure 11-- Booster Placed at a Blast Hole
- Figure 12 - Loading a Blast Hole with ANFO
- Figure 13 - Connecting an E*Star Electronic Detonator to the Buss Line
- Figure 14 -- Arming and Firing the Dan-Mar Digital Blasting Machine
- Figure 15 -- Blast Fired with Austin E*Star Electronic Detonator Blasting System

1. Purpose

This report presents the technical findings and the evaluation of “shunting” and “circuit testing” for the Austin Electro Star (E*Star) electronic detonator blasting system. This evaluation is made with respect to the MSHA explosive and blasting requirements as indicated below. The E*Star electronic detonator blasting system consists of the E*Star electronic detonator with connecting wires, the Dan-Mar digital logger DLG1600-1-N (Dash 1) and digital logger DLG1600-100 (Dash 100) and the Dan-Mar digital blasting machine DBM1600-2-KN.

For electric detonators, the coal and metal-nonmetal mine requirements for shunting and circuit testing are specified in Title 30, Code of Federal Regulations (30 CFR) 77.1303 (y)(1),(2),(3) and 77.1303(z); 56.6401(a),(b),(c); 56.6407(a),(b),(c),(d) and 57.6401 (a),(b),(c) and 57.6407 (a) and 57.6407 (b). Electric blasting systems are designed differently than electronic detonator systems and the operational features are not the same. Also, each electronic detonator blasting system differs in design, construction, operation and testing features.

To resolve the issue of “shunting” and “circuit testing”, technical information was provided by the Austin Powder Company on the details of their E*Star electronic detonator combined as a blasting system with the Dan-Mar Company digital loggers and blasting machine. A trip was also made to examine the Austin E*Star electronic detonator blasting system during use in the field at a surface coal mine blast site.

2. Introduction—Electric Detonators

Electric detonators for blasting operations. Electric detonator systems for performing blasting operations have been in use in the mining industry for many decades. They are used in both series and parallel blasting circuits. All electric detonators produced in the USA have shunts on the free ends of the leg wires. The shunt provides a low resistance path to prevent current from flowing through the bridge wire of the electric detonator. In other words, with a shunt both of the leg wires are at the same potential to prevent extraneous current flow into the detonator. In addition, some designs completely enclose the ends of the wires in order to prevent corrosion and to prevent bare wires from contacting extraneous electrical current sources. The shunt is removed when an electric detonator is connected into the blasting circuit. Electric detonators are supplied with a distinctive, numbered tag to facilitate easy identification of the delay period.

Since electric detonators are designed to fire when electrical energy is supplied to them, any extraneous source of electric current represents a potential source for initiation. Sources such as lightning, high voltage power lines, radio transmitters, and static electricity must be avoided. There are also occurrences where the energy from lightning has traveled several miles along pipes or cables into an underground mine and can represent an unsuspected source for initiation of electric detonators.

When using electric detonators, the continuity and resistance of the individual detonator as well as the entire circuit needs to be tested with a blasting galvanometer. A blasting galvanometer is used to check the individual detonators prior to making the primer and again prior to stemming the borehole. Care should be taken when stemming a borehole to prevent any possible damage to the detonator leg wires. Once the circuit is completely wired, it should be checked again. If several circuits are wired in parallel, the total resistance of the firing circuit must be checked after each individual circuit is wired into the main circuit. When the blast line is connected to the circuit, the resistance needs to be checked prior to connecting the blasting machine.

When electric detonators are initiated, current leakage from the blasting circuit must also be prevented. If bare wires are allowed to come into contact with another conductor or even a conductive portion of the ground, some of the electric energy may leak out of the circuit causing misfires.

3. Technical Discussion

Electric detonator components. An electric detonator consists of two leg wires embedded into a metal shell which contains a high explosive base charge designed to initiate other explosives. Electric detonators are typically designed with an ignition mixture, a pyrotechnic fuse train (for the delay element) and a base charge, respectively (Figure 1). A thin metal filament, known as a bridge-wire, is attached between each end of the leg wires and is embedded in an ignition mixture. The pyrotechnic delay element is designed to burn at an approximated rate. The length and composition of the pyrotechnic train control the approximate rate of burn and thus the timing of when the detonator fires. Since the approximate rate of burn is subject to variation, the firing time accuracy of the electric detonator is affected. When sufficient electrical current passes through the bridge wire, it becomes hot enough to ignite the ignition mixture. This event initiates the pyrotechnic element in the delay train which then initiates the base charge.

Electronic detonator systems. Electronic detonator systems are a technological advancement for the initiation of blasts in mining operations. Their use,

although currently not widespread, continues to expand. Several advantages for electronic detonators are precise timing, reduced vibrations, reduced sensitivity to stray electrical currents and radio frequency emitting devices, and a reduction in misfires through more precise circuit testing.

Electronic detonators have been designed to eliminate the pyrotechnic fuse train that is a component of electric detonators, thus improving timing accuracy and safety. Typically an integrated circuit and a capacitor system internal to each electronic detonator physically separates the leg wires from the base charge and depending on the design features can greatly enhance safety and timing accuracy. The electronic detonator is obviously a more complex design compared to an electric detonator. The core of the electronic detonator is a micro chip timer and a capacitor which takes the place of the pyrotechnic fuse train used in electric detonators. The location of the electronic circuitry inside an electronic detonator provides a barrier to stray current that might cause initiation in a conventional electric detonator. Furthermore, electrical shunts which are built into the circuitry to protect the electronic detonator from static charges eliminate the need for external shunts used with conventional electric detonators. Figure 2 is an example of an electronic detonator.

A blaster's galvanometer cannot be used for resistance and continuity tests because circuit tests must be done with very low voltages and electronic detonator components can be damaged by the voltage a blaster's galvanometer normally generates. Specific circuit testing equipment is designated to perform continuity and resistance tests when electronic detonators are used in the blasting circuit. Tests for continuity and resistance can be done at each borehole and for the network as a whole quickly and safely.

In terms of the electronic blasting system, a specially designed blast controller unique to each manufactured system transmits a selectable digital signal to each wired electronic detonator. The signal is identified by each electronic detonator and the detonation firing sequence is accurately assigned. The manufacturer's control unit or specified logger is used to show any incomplete circuits during hookup prior to initiation of the explosive round. The wired round won't fire until all detonators in the circuit are properly accounted for according to the blasting plan layout.

Austin E*Star Electronic Detonator Blasting System

As part of the resolution of the "shunting" and "circuit testing" issues, a technical evaluation was made of the Austin E*Star electronic detonator blasting system. The design aspects of the E*Star system were evaluated from technical information and details provided by Austin Powder. The basic components of

the Electro*Star (E*Star) electronic detonator are shown in Figure 3. The Electro*Star electronic detonators contain a capacitor, a logic and timing circuit, and pyrotechnic ignition system manufactured by Special Devices Inc., which is integrated with Austin Powders' detonator technology to provide a complete system. The means of shunting for the E*Star electronic detonator is provided by its different design and constructional features than the conventional electric detonator. Internal shunting by protective devices contained in the E*Star detonator replaces the need for an exterior mechanical means of shunting.

Connection of the E*Star electronic detonators into the blasting circuitry is accomplished by using connection blocks. Connector adapters can also be used with connection blocks for a more efficient connection procedure. The Electro*Star electronic detonators are specifically designed for use with the Dan-Mar digital loggers, DLG1600-1-N (Dash 1) and DLG1600-100 (Dash 100) and the Dan-Mar blasting machine (DBM1600-2-KN). These Dan-Mar digital loggers and the Dan-Mar digital blasting machine are shown in Figure 4.

The delay timing for the E*Star detonator can be set individually or as a group. The delays can be set using the Dash 1 or the Dash 100 loggers. The Dash 1 can program E*Star detonators and measure the current of an individual detonator. The Dash 100 can program E*Star detonators, check the current leakage of up to 100 E*Star detonators connected to a buss line, and verify that all detonators are connected to that buss line after all the blast holes are loaded and stemmed. Programming an E*Star detonator includes assigning the detonator number and the delay period. The E*Star detonator delays can be set in 1-millisecond increments from 1 millisecond to 10,000 milliseconds using either the Dash 1 or the Dash 100 digital loggers.

*As part of the improvement in safety to address a previous field issue, the Dash 1 and Dash 100 digital loggers have been programmed to identify a "critical condition" within the E*Star electronic ignition module that can cause the detonator or blast hole in which it is loaded to detonate prematurely when connected to the Dan-Mar DBM1600-2-KN blasting machine. Using the Dash 1 or Dash 100 for E*Star programming, the "critical condition" is detected automatically. Another method to verify the "critical condition" is by placing the Dash 1 or Dash 100 in the current measuring mode which is explained in detail in the Austin Operation Manual for the E*Star system. If the "critical condition" is detected, the defective detonator must not be used in the blast or it must be removed from the buss line or blasting circuit if it has already been loaded into the blast hole.*

A total of 1600 detonators can be programmed at one time using the Dash 100, but not all can be programmed on the same branch. Once the E*Star detonators

are programmed and the blast holes are finished being loaded and stemmed, the detonator connection blocks can be attached to the buss line. After all E*Star electronic detonators have been connected to the buss line, the Dash 100 logger is used to verify the status of all detonators. The logged E*Star detonators can be checked for current up to 100 detonators on a single branch with the Dash 100. Once the shot plan has been electronically verified and compared with the written blasting plan, the entire network is then connected to the lead wire which is extended and connected to the Dan-Mar digital blasting machine.

Subsequent to programming, checking and verifying the E*Star detonators, the data entered into the Dash 1 or Dash 100 loggers is transferred into the Dan-Mar digital blasting machine using a transfer cable. The Dan-Mar digital blasting machine is then used to poll the detonators to verify that each and all of them are communicating and ready to be armed. The Dan-Mar digital blasting machine can charge and fire up to 1600 E*Star detonators. The bench/blast area must be cleared of equipment and personnel before using the Dan-Mar digital blasting machine to communicate with the E*Star detonators. After the bench/blast area is cleared, a verification of the circuit is performed with the Dan-Mar digital blasting machine and the shot is fired after all detonator and circuit tests are positive.

4. Mine Field Trials

A field trip was made to a surface coal mine operation in eastern Ohio on February 9, 2007, to examine and witness the use of the Austin E*Star electronic detonator blasting system. The visit at the mine site included an examination of the primary components of the Austin E*Star blasting system which consisted of the E*Star electronic detonator, the Dan-Mar digital loggers, DLG1600-1-N (Dash 1) and DLG1600-100 (Dash 100) and the Dan-Mar blasting machine (DBM1600-2-KN). Each step of the blasting procedure was witnessed. The system performed very well in the field. The system detected open blasting circuits which enabled the blasting crew to specifically locate and correct the fault while setting up the blasting network. This feature serves to prevent misfires from occurring and causing a safety hazard.

The blast pattern consisted of 49 holes that were six and three fourth inches in diameter. The depth of the blast holes ranged from 20 to 24 feet. There were five rows of blast holes with a spacing of 15 feet. The face height was 24 feet and the burden was 15 feet.

The Austin E*Star electronic detonators used were packed in 10 count cardboard boxes bundled with 40 foot leg wires and a connector block as shown in Figure 5. The wires for each E*Star detonator were plugged into the Dash 1 logger via the

connector block and adapter (Figure 6) and assigned an identification number and firing time. The detonator was also tested for circuit continuity and current integrity (Figure 7). Each branch of E*Star detonators was checked from the end of the branch using the Dash 100 logger to verify that each detonator was communicating and in the correct location. The Dash 100 logger is shown in Figure 8 along with the Dash 1 logger. Each E*Star detonator was queried and an E*Star detonator (#49) was found to be missing. This situation was corrected and demonstrated that the logger could detect the condition of the circuitry in the blast layout and report it accurately to the blaster.

In another example, a defective detonator (dummy) was connected to the Dash 100 logger. The Dash 100 logger detected the defect as shown in Figure 9.

As part of the blasting procedure, a depth-of-blast-hole check was made (Figure 10). The boosters and E*Star electronic detonators were laid out near the collar of each blast hole. A booster is shown in Figure 11. An E*Star detonator was inserted into a booster to create a primer. The primer was lowered into each blast hole prior to loading with an ammonium nitrate and fuel oil (ANFO) blasting agent. The blasting agent was pumped into each blast hole from an ANFO bulk loading truck (Figure 12). The E*Star detonators were then connected to the buss line (Figure 13).

After verifying the shot to be fire was properly set up, the entire network was then connected to the lead wire. The lead wire was then extended from the bench to the blast initiation area for it to be connected to the Dan-Mar digital blasting machine once the blast area was cleared. After the blast area was secured, the lead wire was inserted into the appropriate terminals of the Dan-Mar digital blasting machine, the blaster keyed his personal identification code and activated communication with the E*Star detonator in each blast hole. The blaster then ran another diagnostic on the entire blasting network and verified the shot area was properly cleared of personnel and equipment before radioing for the blast warning sirens to sound. After the third and final siren, the Dan-Mar digital blasting machine was armed to fire the detonators (Figure 14). Thirty seconds passed for the electronic arming procedure to complete and then the blast was initiated. All the blast holes fired and there was little vibration and noise from the blast. Figure 15 shows an overview of the blast result.

The Austin E*Star electronic detonator blasting system performed as intended. The diagnostic evaluation and testing and field performance of the E*Star detonators with the Dash 1 and Dash 100 loggers and the Dan-Mar digital blasting machine satisfied the MSHA requirement for circuit testing.

State of Virginia, Division of Mineral Mining – Field Trials

In addition to the field trial witnessed by MSHA as indicated above, the Austin Powder Company used the E*Star electronic detonator blasting system at two mine quarry sites in Virginia. Both of the trials were witnessed by personnel from the Division of Mineral Mining, State of Virginia. One trial was conducted on February 20, 2007, at a mine quarry east of Lynchburg, VA. The trial consisted of 21 blast holes loaded with 24 electronic detonators. Three blast holes were loaded with two detonators each as a precaution due to the wet conditions encountered in those holes. The second trial was conducted on February 23, 2007, at a mine quarry north of Amherst, VA. This trial consisted of 41 blast holes loaded with 43 electronic detonators. Two of the blast holes were doubled capped due to wet conditions. The Austin E*Star electronic detonator blast system performed as designed in the two mine quarry trials.

5. Conclusions

The shunting issue was evaluated in the technical review of the Austin E*Star electronic detonator. The internal means of shunting for the E*Star electronic detonator is provided by its different design and constructional features than the conventional electric detonator. Extensive testing was performed on the E*Star electronic detonator components which included sources of stray and extraneous electricity and the safety aspects are a significant improvement over conventional electric detonators. The internal shunting via protective devices contained in the Austin E*Star electronic detonator replaces the need for a mechanical means of shunting. The Austin E*Star electronic detonator blasting system with the Dash 1 and Dash 100 digital loggers and with the verification provided by Dan-Mar digital blasting machine (DBM1600-2-KN) meets the intended MSHA requirements for circuit testing. From the detailed technical and field evaluation made by MSHA, the Austin E*Star electronic detonator blasting system does not need to be physically shunted and circuit tested by using a blaster's galvanometer as would be performed for conventional electric detonators. Physical shunts as used on conventional electric detonators and circuit testing with a blaster's galvanometer are not appropriate for the Austin E*Star electronic detonator blasting system.

Also, the Dash 1 and Dash 100 digital loggers have been programmed to identify a "critical condition" within the E*Star electronic ignition module that can cause the detonator or blast hole in which it is loaded to detonate prematurely when connected to the Dan-Mar DBM1600-2-KN blasting machine. Using the Dash 1 or Dash 100 for E*Star programming, the "critical condition" is detected automatically. If the "critical condition" is detected, the defective detonator

must not be used in the blast or it must be removed from the buss line or blasting circuit if it has already been loaded into the blast hole.

Because of the design and construction of the Austin E*Star electronic detonator blasting system, it must be used according to the manufacturer's instructions. Proper training must be obtained prior to using the Austin E*Star electronic detonator blasting system.

6. Summary

Electronic detonator systems are a technological advancement in blasting for the mining industry. Their advantage is thorough pre-blast circuit testing procedures and far more precise detonator firing times than available with electric detonators. These safety features are obtained via the use of integrated circuit chips, internal capacitors, and other proprietary electronic features. The electronic detonator blasting systems MSHA has observed offer unparalleled security in that they cannot be initiated by a conventional blast control unit nor can they be activated without entering security codes. However, electronic detonators are not hazard free and can still be initiated by extraneous sources such as lightning, fire, and high physical impacts. Therefore they must be stored and handled with the same prudence currently used with any other high explosive. It is anticipated that a decrease in misfires and other typical detonator malfunctions should result from the use of electronic detonator systems, thereby increasing the level of safety in blasting operations.

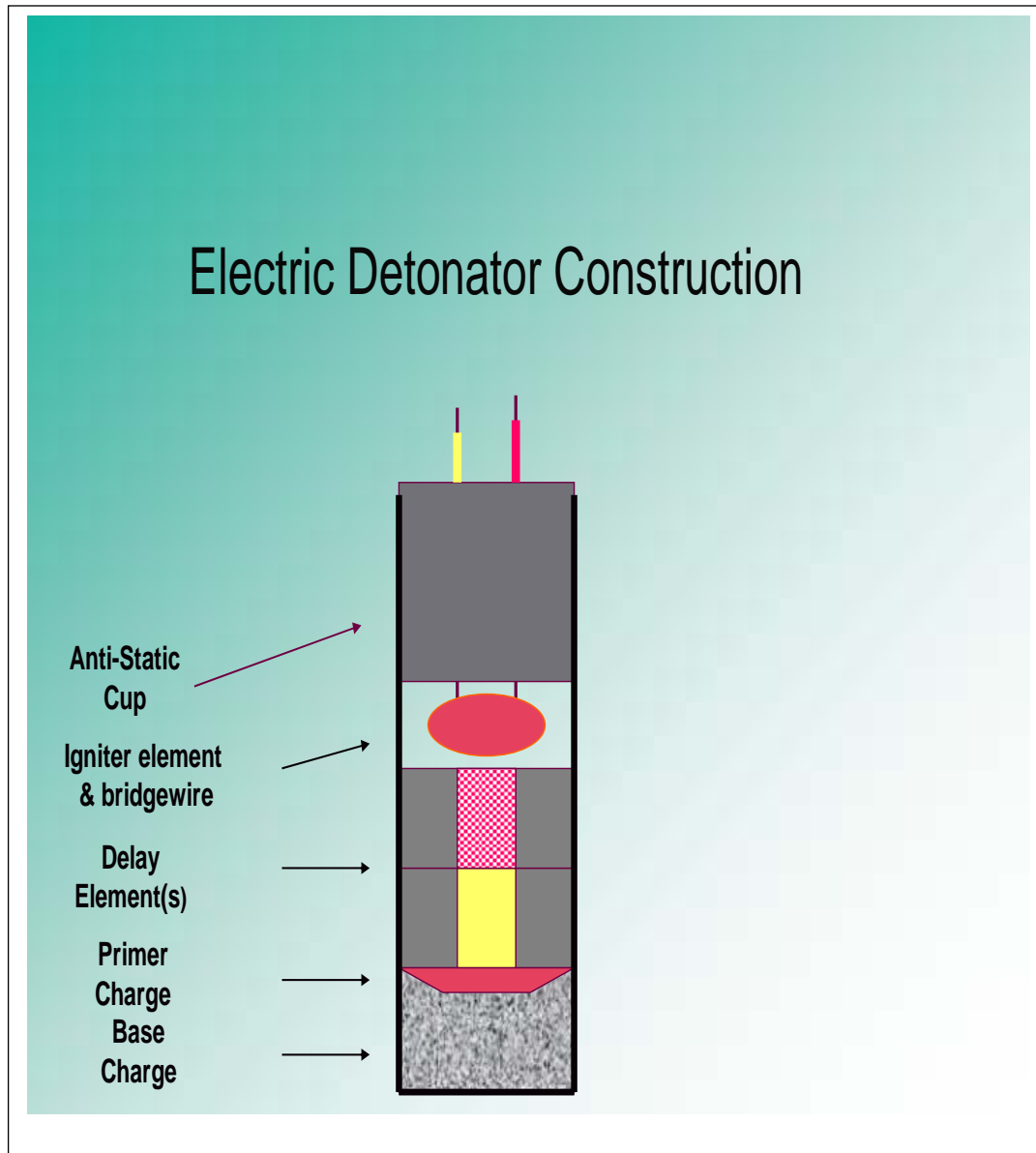

Figure 1 - Electric Detonator Components

Electronic Detonator

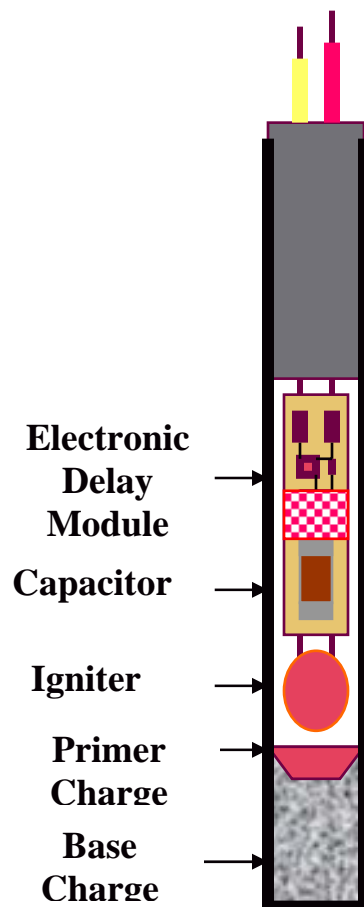

Figure 2 – An Example of Electronic Detonator Components

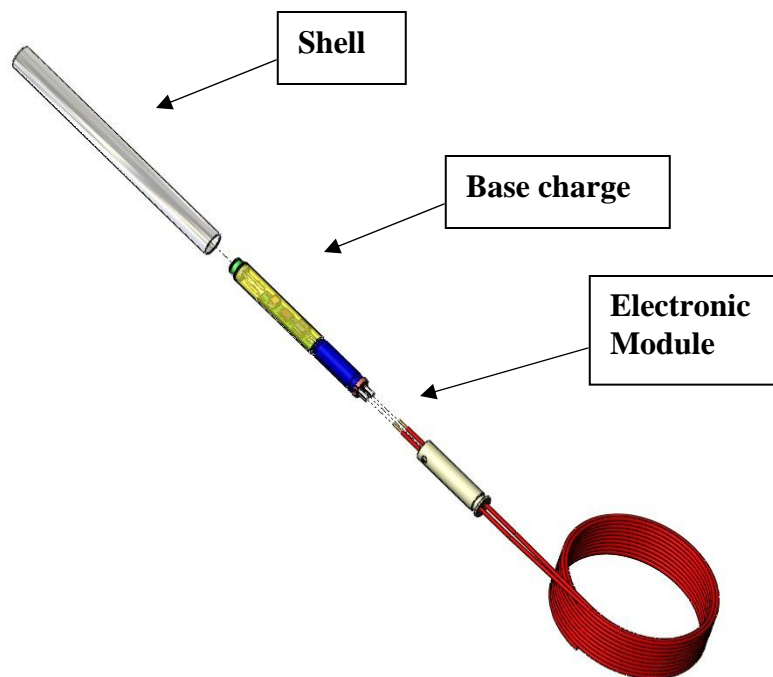

Figure 3 – Austin E*Star Electronic Detonator



Figure 4 – Austin E*Star Electronic Detonator Blasting System



Figure 5 – Austin Electro*Star Electronic Detonators with Connector Block

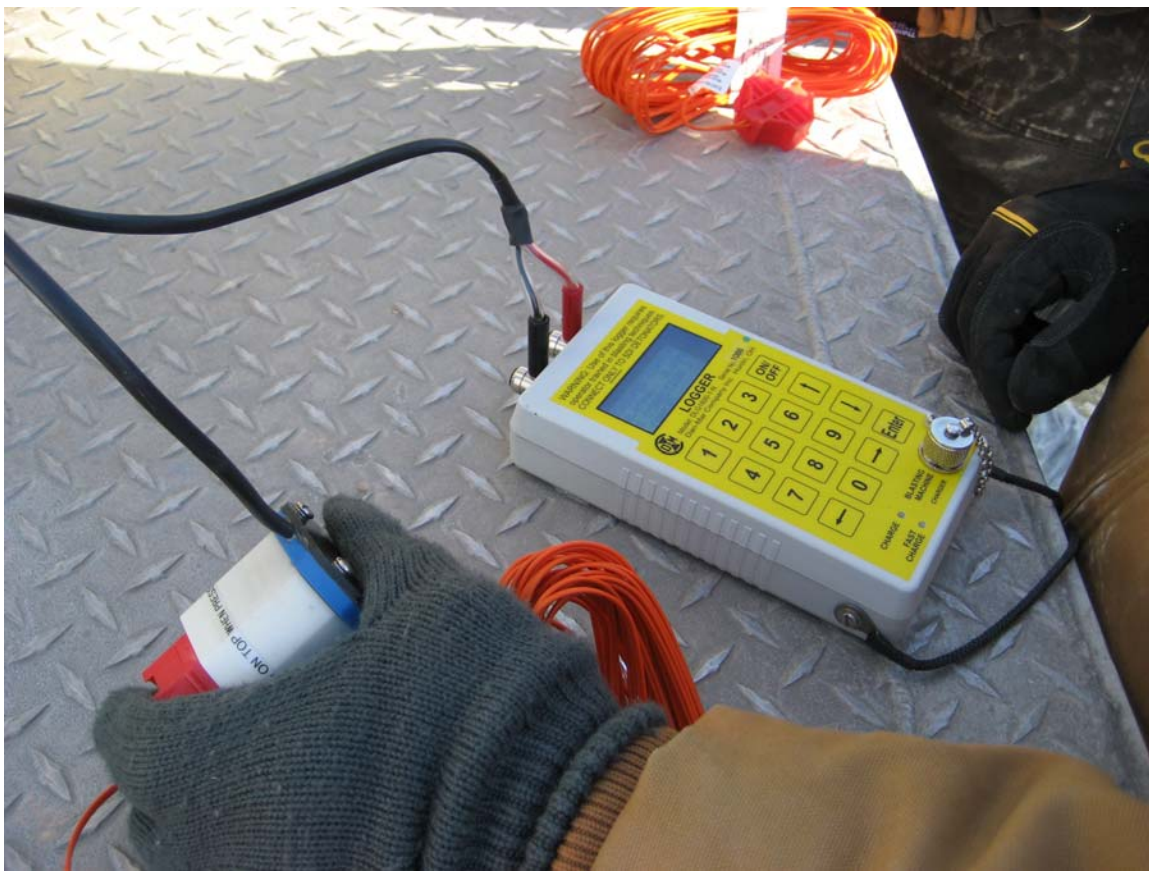

Figure 6 – E*Star Electronic Detonator Connected to the Dash 1 Logger



Figure 7 – Current Test of an E*Star Electronic Detonator using the Dash 1 Logger

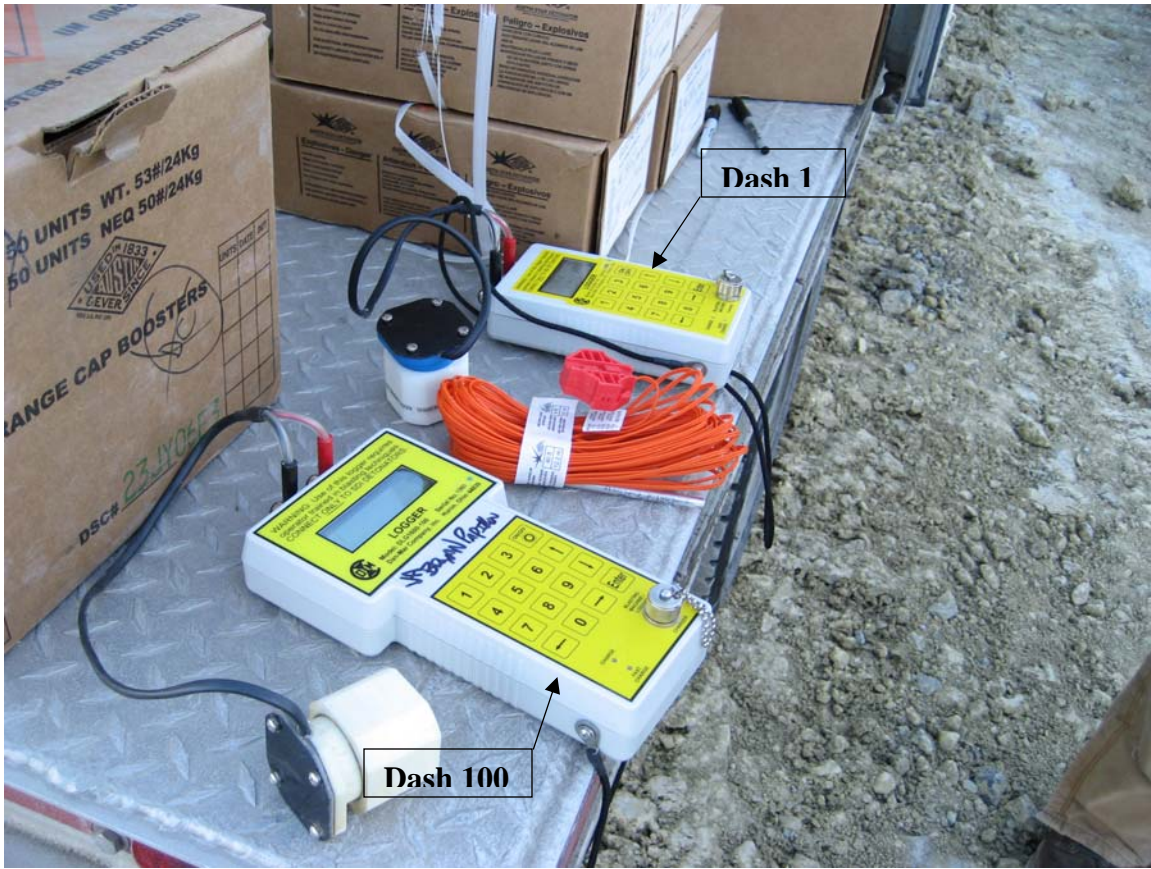

Figure 8 – Dash 1 and Dash 100 Loggers



Figure 9 – Dash 100 Logger Showing Defective Detonator (Dummy)



Figure 10 – Check on Depth of Blast Hole



Figure 11 – Booster Placed at a Blast Hole



Figure 12 – Loading a Blast Hole with ANFO



Figure 13 – Connecting an E*Star Electronic Detonator to the Buss Line



Figure 14 – Arming and Firing the Dan-Mar Digital Blasting Machine



Figure 15 – Blast Fired with Austin E*Star Electronic Detonator Blasting System