

Table of contents

4	Designing equipment for maintenance	4-1
4.1	General.....	4-1
4.1.1	General design guidance.....	4-1
4.1.2	Emphasizing maintenance during design.....	4-3
4.1.3	Optimize skills and training.....	4-4
4.1.4	Minimizing need for maintenance	4-5
4.2	Designing equipment for handling.....	4-5
4.2.1	General.....	4-5
4.2.2	Weight.....	4-6
4.2.3	Size.....	4-8
4.2.4	Shape.....	4-8
4.2.5	Handles	4-8
4.2.5.1	When handles are needed.....	4-8
4.2.5.2	Handle characteristics	4-9
4.2.5.3	Dimensions	4-10
4.2.5.4	Location	4-12
4.2.6	Grasp areas.....	4-13
4.2.7	Stands and rests.....	4-13
4.2.8	Alignment aids	4-14
4.2.9	Designing for remote handling.....	4-14
4.2.10	Designing for use of hoists, jacks, and cranes	4-15
4.3	Packaging, arrangement, and mounting of equipment.....	4-15
4.3.1	Unitization of equipment	4-16
4.3.2	Interchangeability, non-interchangeability	4-17
4.3.3	Mounting in drawers, on racks, and on hinges	4-18
4.3.3.1	General.....	4-18
4.3.3.2	Restraints and supports	4-19
4.3.3.3	External connectors and interlocks	4-19
4.3.4	Positioning equipment	4-20
4.3.4.1	Physical accessibility	4-20
4.3.4.2	Relative accessibility	4-21
4.3.5	Labeling and marking	4-22
4.3.5.1	Types of labels.....	4-22
4.3.5.2	Location and orientation	4-23
4.3.5.3	Typographic matters	4-24
4.3.5.4	Wording.....	4-25
4.3.5.5	Markings	4-26
4.4	Access openings.....	4-27
4.4.1	General.....	4-27
4.4.2	Access	4-27
4.4.3	Size.....	4-28
4.4.4	Shape.....	4-31
4.4.5	Location	4-31
4.4.6	Labeling and marking	4-32
4.5	Cases, covers, guards, and shields	4-33

4.5.1	General.....	4-33
4.5.2	Size.....	4-36
4.5.3	Shape.....	4-37
4.5.4	Hinged covers.....	4-37
4.5.5	Sliding doors and caps.....	4-37
4.5.6	Interlocks.....	4-38
4.5.7	Labeling and marking.....	4-39
4.6	Fasteners.....	4-40
4.6.1	General.....	4-40
4.6.2	Number.....	4-43
4.6.3	Types.....	4-43
4.6.3.1	Nuts and bolts.....	4-43
4.6.3.2	Screws.....	4-44
4.6.3.3	Screw and bolt heads.....	4-45
4.6.3.4	Latches and catches.....	4-46
4.6.3.5	Other fastening devices.....	4-47
4.6.3.6	Quick fastening and releasing devices.....	4-49
4.6.3.7	Captive versus removable.....	4-50
4.6.4	Labeling, marking, and coding.....	4-50
4.7	Connectors.....	4-51
4.7.1	General.....	4-51
4.7.2	Types.....	4-52
4.7.2.1	Distinctive.....	4-52
4.7.2.2	Plug-in.....	4-52
4.7.2.3	Threaded.....	4-52
4.7.2.4	Quick-action.....	4-53
4.7.3	Location and accessibility.....	4-53
4.7.4	Alignment aids.....	4-54
4.7.5	Electrical connections.....	4-55
4.7.5.1	Plugs and receptacles.....	4-55
4.7.5.2	Wire connections.....	4-56
4.7.6	Labeling, marking, and coding.....	4-58
4.8	Lines and cables.....	4-59
4.8.1	Electrical.....	4-59
4.8.1.1	General.....	4-59
4.8.1.2	Length of cables and leads.....	4-61
4.8.1.3	Routing and mounting.....	4-63
4.8.1.4	Leads.....	4-65
4.8.1.5	Clamps and mounting plates.....	4-65
4.8.1.6	Test and extension cables.....	4-67
4.8.1.7	Bench mockup cables.....	4-68
4.8.1.8	Labeling, marking, and coding.....	4-69
4.8.2	Fluid and gas lines.....	4-71
4.8.2.1	General.....	4-71
4.8.2.2	Routing and mounting.....	4-72
4.8.2.3	Clamps and supports.....	4-73

4.8.2.4 Gaskets and seals	4-73
4.8.2.5 Labeling, marking, and coding	4-75
4.9 Packaging, layout, and mounting of internal components	4-79
4.9.1 General	4-79
4.9.2 Packaging	4-80
4.9.2.1 Modularization	4-80
4.9.2.2 Modularization methods	4-81
4.9.3 Layout	4-82
4.9.3.1 Accessibility	4-82
4.9.3.2 Grouping of parts	4-83
4.9.3.3 Hazard protection	4-84
4.9.4 Mounting	4-85
4.9.5 Labeling and marking	4-87
4.10 Adjustment controls	4-89
4.11 Fuses and circuit breakers	4-91
4.11.1 General	4-91
4.11.2 Fuses	4-92
4.11.3 Push-pull circuit breakers	4-93
4.11.4 Toggle bat and legend switch circuit breakers	4-95
4.11.5 Labeling and marking	4-97
4.12 Test points and service points	4-97
4.12.1 Adjustment controls	4-97
4.12.2 Location and arrangement	4-98
4.12.3 Drain points	4-99
4.12.4 Accessibility	4-100
4.12.5 Safety	4-101
4.12.6 Labeling, marking, and coding	4-102
4.13 Test equipment	4-103
4.13.1 General	4-103
4.13.1.1 General characteristics	4-103
4.13.1.2 Safety	4-104
4.13.1.3 Ease of use	4-104
4.13.1.4 Controls and displays	4-105
4.13.2 Built-in test equipment (and partially built-in, portable, and test panels)	4-106
4.13.2.1 Completely built-in test equipment	4-106
4.13.2.2 Partially built-in test equipment	4-106
4.13.2.3 Portable test equipment	4-107
4.13.2.4 Built-in test panel	4-107
4.13.3 Test equipment	4-108
4.13.4 Bench mockups	4-109
4.13.5 Storage space	4-110
4.14 Tools	4-110
4.14.1 General	4-110
4.14.2 Common hand tools	4-111
4.14.3 Special tools	4-111
Glossary	4-112

References.....	4-114
Index	4-115

List of exhibits

Exhibit 4.2.2.1	Maximum weight limits for objects lifted by one person using both hands	4-6
Exhibit 4.2.5.1.5	Maximum force limits for pulling and pushing units of equipment using handles or grasp areas.	4-9
Exhibit 4.2.5.3.1	Minimum handle dimensions	4-11
Exhibit 4.2.5.3.2	Minimum handle diameter required by weight of unit of equipment	4-12
Exhibit 4.3.5.3.1	Minimum character height for various viewing distances	4-24
Exhibit 4.3.5.5.2	Recommended colors	4-26
Exhibit 4.3.5.5.3	Good and bad arrows	4-26
Exhibit 4.4.3.2	Minimum dimensions of openings designed for access by one or two fingers without visual access.....	4-28
Exhibit 4.4.3.3	Minimum dimensions of openings designed for access by one hand or arm without visual access.....	4-29
Exhibit 4.4.3.4	Minimum dimensions of openings designed for access by two hands without visual access.....	4-30
Exhibit 4.5.1.2	Type of covering for type of access and environmental conditions.....	4-34
Exhibit 4.6.3.3.2	Examples of combination-head bolts and screws	4-45
Exhibit 4.6.3.3.4	Example of an internal-wrenching bolt and nut.....	4-46
Exhibit 4.7.2.4	Example of a quick-action connector.....	4-53
Exhibit 4.7.5.2.2	Example of a crimp-on splice.	4-57
Exhibit 4.7.5.2.5	Examples of a U-lug and an O-lug.....	4-57
Exhibit 4.8.1.1.5	Fanning out cables.....	4-60
Exhibit 4.8.1.1.13	Cable winder	4-61
Exhibit 4.8.1.2.6	Recoiling slack cable.....	4-63
Exhibit 4.8.1.5.3	Quick-release clamps, hinged and spring.....	4-66
Exhibit 4.8.1.6.6	An example of a line and cable reel cart.....	4-67
Exhibit 4.8.1.6.8	Line and cable mobile support.....	4-68
Exhibit 4.8.1.8.4	Electrical cable coding	4-70
Exhibit 4.8.2.4.7	Externally visible seals.....	4-74
Exhibit 4.8.2.5.1	Color-coding of fluid conductors.....	4-75
Exhibit 4.8.2.5.2	Valve color-coding scheme.....	4-76
Exhibit 4.8.2.5.3	Hydraulic and pneumatic line color-coding scheme.....	4-77
Exhibit 4.8.2.5.5	Value position labeling	4-78
Exhibit 4.9.4.1	Example of foldout mounting construction.....	4-85
Exhibit 4.9.4.7	Error-free mounting provisions.....	4-86
Exhibit 4.11.1.1	General comparison of fuses and circuit breakers	4-92
Exhibit 4.11.3.1	Push-pull circuit breaker specifications	4-94
Exhibit 4.11.4.1	Toggle bat specifications.....	4-95
Exhibit 4.11.4.2	Legend switch specifications.	4-96
Exhibit 4.12.2.13	Terminal strips	4-99
Exhibit 4.12.4.4 (a)	Test plug with sliding cover	4-101
Exhibit 4.12.4.4 (b)	Test point adapter	4-101

4 Designing equipment for maintenance

This section contains human factors rules intended to make equipment maintenance easy, fast, and safe. Equipment maintenance does not, of course, occur in isolation. The overall system of which the equipment is a part affects the design of the equipment; for example, if the system must run continuously, the equipment might be designed to allow maintenance while it is in operation, or some sort of redundancy might be provided. The system maintenance concept also affects equipment design; for example, is a particular unit of equipment intended to be repaired on site? Is it intended to be removed and repaired at another location? Or is it intended to be discarded and replaced with another unit? A third factor affecting equipment design is the physical environment in which it will be located; will it be exposed to weather or to temperature extremes? Will the user be wearing gloves or other protective clothing? Finally, equipment must accommodate characteristics of the users themselves, their sizes and shapes, their skills, and their training.

4.1 General

This section contains rules for: (a) designing equipment in general, (b) emphasizing maintenance during the design of equipment, modules, and components, (c) maximizing the use of existing equipment and tools, (d) minimizing the skill and training requirements for users, and (e) minimizing the need for maintenance.

4.1.1 General design guidance

One of the most important aspects of designing equipment for maintenance is the breaking up of a unit of equipment into modules that are independent, interchangeable, and easily replaced. If warranted, these modules can also be disposable. Other important aspects are: ease of access to test and service points, ease of access to internal parts and components, and, if warranted, built-in testing, diagnostic and fault localization capability.

Definitions. A **unit of equipment** is an assemblage of items that may include modules, components, and parts that are packaged together into a single hardware package. For example, a computer, its keyboard, and its visual display are all units of equipment, as are radio transmitters and receivers. A **module** is an assemblage of two or more interconnected parts or components that comprise a single, physical and functional entity. It is this singular functionality that defines a module. A **component** is a subdivision of a unit of equipment that can be treated as an object by the user, but which can be further broken down into parts. A mounting board together with its mounted parts is an example of a component. A **part** is an object that cannot normally be broken down further

without destroying its designated use. Fuses, resistors, and capacitors are examples of parts.

- **4.1.1.1 General design guidance.** The following features should be incorporated into the design of all equipment, modules, and components, as appropriate:
 - a. simplification of maintenance functions,
 - b. modularization of equipment and components,
 - c. minimization of the number and complexity of maintenance tasks,
 - d. use of built-in testing, diagnostic, and fault localization capabilities,
 - e. use of disposable modules, components, and parts, where cost effective and appropriate,
 - f. simplification of design,
 - g. quick and easy access to all units of equipment, modules, components and parts that require maintenance, inspection, removal, or replacement,
 - h. compliance with lifting, carrying, and force criteria,
 - i. minimization of the numbers and types of tools and test equipment required for maintenance,
 - j. design alternatives dependent on the skills and training needed by maintainers and operators,
 - k. maximization of the safety and protection of users and equipment,
 - l. ease of assembly, disassembly, installation, and removal,
 - m. elimination of precise torque requirements,
 - n. ability to perform maintenance from above and outside rather than from underneath and inside,
 - o. use of self lubrication, and
 - p. use of sealed and lubricated modules. [Source: Department of Defense (MIL-HDBK-759B), 1992]

- **4.1.1.2 Use of existing items.** If an existing unit of equipment, module, component, or part meets the relevant requirements and the applicable human engineering criteria in this document, designers shall use that existing item rather than design a new one. [Source: AFSC DH 1-3, 1980; MIL-STD-1472F, 1999]

Discussion. Relevant requirements include performance, maintainability, and reliability criteria designated by the acquisition program office. [Source: AFSC DH 1-3, 1980; MIL-STD-1472F, 1999]

Definition. Item is a nonspecific term used to denote any product, available or in design or development, including parts, components, modules, and units of equipment. [Source: AFSC DH 1-3, 1980; MIL-STD-1472F, 1999]

4.1.2 Emphasizing maintenance during design

- **4.1.2.1 Non-interruption of continuous operation.** Equipment that is part of a system that must operate continuously shall be capable of undergoing maintenance without interrupting the operation. [Source: NASA-STD-3000A, 1989]
- **4.1.2.2 Redundancy to prevent interruption.** If continuous operation is required and required maintenance on a unit of equipment would interrupt the operation, redundant equipment shall be provided. [Source: NASA-STD-3000A, 1989]
- **4.1.2.3 Degraded operation.** When warranted by its importance in a system, a unit of equipment that has a partial failure shall be designed to operate in a degraded mode while awaiting maintenance. This degraded operation shall not cause damage to other equipment or components, nor shall it aggravate the original fault. Degraded operation and faults shall be sensed and appropriate information identified, displayed, or transmitted to users and, if appropriate, to operators. [Source: NASA-STD-3000A, 1989]
- **4.1.2.4 Automation of fault detection and isolation.** When warranted, equipment shall have automatic fault detection and isolation capability. [Source: NASA-STD-3000A, 1989]
- **4.1.2.5 Equipment independence for maintenance.** Units of equipment shall be as independent (functionally, mechanically, electrically, and electronically) as is practical (see Paragraph 4.3.1.1). [Source: NASA-STD-3000A, 1989]

- **4.1.2.6 Designing for safety of users.** Equipment shall not present hazardous conditions to users as they perform maintenance procedures. A positive means (for example, disconnects or lockouts) shall be designed into equipment and used to control hazardous conditions and facilitate safety as outlined in OSHA 29 CFR 1910.147. [Source: 29 CFR 1910.147; NASA-STD-3000A, 1989]

Definitions. A **hazardous condition** is the presence of energy or a substance which is likely to cause death or injury by reason of physical force, shock, radiation, explosion, flames, poison, corrosion, oxidation, irritation or other debilitation. Biological and chemical hazards can have debilitating effects through disease or interference with physiological functions. A **hazardous location** is a space within a facility, room, or open environment where a hazardous condition exists or is accessible or exposed within the system or equipment located within the space. [Source: NASA-STD-3000A, 1989]

- **4.1.2.7 Dividing equipment into modules.** Heavy, large, or complex equipment should be divided into modules. [Source: AFSC DH 1-3, 1980]

Discussion. Modularization of equipment can make it easier to: (a) locate and isolate malfunctions, (b) properly allocate maintenance functions and responsibilities, (c) reach, remove, and maintain components, and (d) handle the equipment for installation and repair. [Source: AFSC DH 1-3, 1980]

- **4.1.2.8 Replacement of failed components.** Equipment shall be designed so that components that fail frequently (such as lamps and fuses) can be easily replaced. [Source: NASA-STD-3000A, 1989]

4.1.3 Optimize skills and training

- **4.1.3.1 Optimize balance between use, maintenance, and special skills.** As practical, the balance between ease of use, maintenance, and the need for special skills on the part of the users should be optimized. [Source: NASA-STD-3000A, 1989]
- **4.1.3.2 Optimize balance between ease of use and training.** As practical, optimize the balance between ease of use and training on the part of the users. Special training shall only be required when equipment or automation is implemented or has undergone major modification. [Source: NASA-STD-3000A, 1989]

4.1.4 Minimizing need for maintenance

- **4.1.4.1 Ease of servicing.** Equipment shall be designed so that it can be serviced in its installed position. [Source: AFSC DH 1-3, 1980]
- **4.1.4.2 Minimize maintenance time.** Equipment shall be designed to minimize the time required for maintenance. [Source: NASA-STD-3000A, 1989]

4.2 Designing equipment for handling

The purpose in designing equipment for handling is to increase the efficiency of the user and to reduce the likelihood of injury to the user or damage to the equipment. The topics covered in this section include (a) the weight, size, and shape of the equipment, (b) the provision of handles and grasp areas, (c) the provision of stands, rests, and alignment aids, (d) designing for remote handling, and (e) designing for the use of hoists, jacks, and cranes.

4.2.1 General

- **4.2.1.1 Prevention of damage.** Units of equipment shall be designed, located, and protected so that they will not be damaged when they are stored, shipped, handled, installed, operated, or maintained. Susceptibility to damage shall be clearly identified. Procedural guidance and suitable warning labels shall be provided to help prevent such damage. [Source: MIL-STD-1800A, 1990]
- **4.2.1.2 Minimal number of maintainers.** Units of equipment shall be designed, placed, and mounted so that they can be installed and removed by a minimum number of people wearing clothing appropriate to the environment. [Source: MIL-STD-1472F, 1999]

4.2.2 Weight

The weight limits provided in this section assume that they will be lifted by able-bodied people.

- **4.2.2.1 Maximum weight of units of equipment to be lifted by one person.** If a unit of equipment is designed to be lifted by a single person, its weight shall not exceed the value in Exhibit 4.2.2.1 that is appropriate for the height to which it is to be lifted and the size of the unit as it affects the distance between the body and the grip. [Source: MIL-HDBK-759B, 1992; MIL-STD-1472F, 1999]

Exhibit 4.2.2.1 Maximum weight limits for objects lifted by one person using both hands

Height to which lifted	460 mm (18 in)	610 mm (24 in)	150 mm (6 in)	300 mm (12 in)
.9 m (3 ft)	20.2 kg (44 lb)	13.3 kg (29.3 lb)	10.1 kg (22 lb)	6.6 kg (14.7 lb)
1.5 m (5 ft)	16.8 kg (37 lb)	11.2 kg (24.7 lb)	8.4 kg (18.5 lb)	5.6 kg (12.3 lb)

- **4.2.2.2 Lifting in the presence of obstacles.** The values given in Exhibit 4.2.2.1 assume that there are no obstacles between the person lifting and the surface onto which the object is to be placed. If there is an obstacle, such as a lower shelf, the weight limit shall be reduced by 33% for an obstacle protruding 300 mm (12 in), 50% for an obstacle protruding 460 mm (18 in), and 66% for an obstacle protruding 610 mm (24 in). No lift shall be performed at a reach distance greater than 635 mm (25 in). If the allowable weight must be reduced by both size (distance between body and grip) and obstacle considerations, only the more restrictive single value shall apply, that is, two reductions shall not be applied. [Source: MIL-STD-1472F, 1999]
- **4.2.2.3 Maximum weight of units of equipment to be lifted by two people.** If a unit of equipment is designed to be lifted by two people, the weight lifted by either one of them shall not exceed the appropriate value given in Exhibit 4.2.2.1; thus, if the weight of the unit is distributed uniformly, the maximum weight is twice that for a single person. [Source: MIL-STD-1472F, 1999]

- **4.2.2.4 Maximum weight of units of equipment to be lifted by three or more people.** If a unit of equipment is designed to be lifted by three or more people, the weight lifted by any one of them shall not exceed the appropriate value given in Exhibit 4.2.2.1. The maximum weight of the unit may be increased by three-fourths of the single person value for each person in addition to the first. Thus, the maximum weight shall not exceed

$$X + 0.75(N-1) X$$

where X is the appropriate value from Exhibit 4.2.2.1, and N is the number of people lifting. This increase assumes that the unit is large enough that the people lifting do not interfere with each other. [Source: MIL-STD-1472F, 1999]

- **4.2.2.5 Maximum weight of units of equipment to be carried by one person.** The weight of a unit of equipment designed to be carried by one person shall not exceed 16 kg (35 lb). This limit applies to carrying distances up to 10 m (33 ft). [Source: MIL-STD-1472F, 1999]
- **4.2.2.6 Maximum weight of units of equipment to be carried by more than one person.** If a unit of equipment is designed to be carried by two people, the weight carried by either one of them shall not exceed 19 kg (42 lb); thus, if the weight of the unit is distributed uniformly, the maximum weight of the unit is 38 kg (84 lb). This limit applies to carrying distances up to 10 m (33 ft). [Source: MIL-STD-1472F, 1999]
- **4.2.2.7 Maximum weight of units of equipment to be carried by more than two people.** If a unit of equipment is designed to be carried by more than two people, the total weight shall not exceed 19 kg (42 lb) plus 14.3 kg (31.5 lb) for each person carrying in addition to the first. This increase in weight assumes that the unit is large enough that the people carrying do not interfere with each other. This limit applies to carrying distances up to 10 m (33 ft). [Source: MIL-STD-1472F, 1999]
- **4.2.2.8 Lifting eyes or jacking points.** Units of equipment weighing more than 68 kg (150 lb) shall have lifting eyes or jacking points (see Paragraph 4.2.10 Designing for use of hoists, jacks, and cranes). [Source: AFSC DH 1-3, 1980; MIL-HDBK-759B, 1992; MIL-STD-1800A, 1990]
- **4.2.2.9 Reducing weight by removing parts.** Heavy pieces of equipment should be made more manageable by designing them with removable parts. [Source: AFSC DH 1-3, 1980]
- **4.2.2.10 Labeling heavy units.** Any unit of equipment heavier than 13.6 kg (30 lbs) or designed to be lifted or carried by more than one person shall be labeled according to Paragraph 4.3.5.1.3. [Source: MIL-STD-1800A, 1990]

4.2.3 Size

The size of a unit of equipment affects its weight limits; a large unit intended to be handled by one person cannot weigh as much as a smaller one, as can be seen in Exhibit 4.2.2.1. Similarly, a unit intended to be handled by two or more people that is so small that the people interfere with each other cannot weigh as much as a unit that is large enough to avoid such interference.

- **4.2.3.1 Desirable size.** Each unit of equipment should be small enough for one person to lift or carry. [Source: AFSC DH 1-3, 1980]
- **4.2.3.2 Reducing size by removing parts.** Units of equipment that are too large to be handled by one person should be designed with removable parts to reduce their size. [Source: AFSC DH 1-3, 1980]

4.2.4 Shape

- **4.2.4.1 Avoiding protuberances.** Equipment shall be designed with a minimum number of bulges or extensions that might interfere with handling. [Source: MIL-STD-1472F, 1999]
- **4.2.4.2 Removing protuberances.** If a unit of equipment includes irregular bulges or extensions that make handling difficult, the bulges or extensions shall be easily removable by hand or with common hand tools. [Source: MIL-STD-1472F, 1999; MIL-STD-1800A, 1990]

4.2.5 Handles

A handle is a permanent part of a unit of equipment that is designed to be grasped by the hand. Handles may extend out from the unit so that the fingers wrap around them, or they may be recessed areas so that the fingers fit inside an opening. Extended handles may be rigid or folding.

The size, number, and location of handles depend upon: (a) the weight and center of gravity of the unit, (b) the number of people lifting or carrying the unit, (c) the type of clothing worn and whether or not gloves are worn, (d) the position of the unit before handling and its final position, (e) the frequency with which the unit is handled, and (f) any additional uses the handles may serve. [Source: UCRL-15673, 1985]

4.2.5.1 When handles are needed

- **4.2.5.1.1 Units of equipment designed for carrying.** Units of equipment intended to be carried shall have handles or grasp areas. [Source: MIL-HDBK-759B, 1992; MIL-STD-1800A, 1990]

- **4.2.5.1.2 Units of equipment weighing less than 4.5 kg (10 lb).** Units of equipment weighing less than 4.5 kg (10 lb) shall have handles if they would otherwise be difficult to grasp, remove, or carry. [Source: AFSC DH 1-3, 1980; MIL-HDBK-759B, 1992]
- **4.2.5.1.3 Units of equipment weighing between 4.5 and 18 kg (10 to 40 lb).** Units of equipment weighing between 4.5 kg (10 lb) and 18 kg (40 lb) shall have one or more handles that permit easy handling of the unit by one person. If the unit is bulky or if its weight is unevenly distributed, the handles shall permit easy handling by two people. [Source: AFSC DH 1-3, 1980; UCRL-15673, 1985]
- **4.2.5.1.4 Units of equipment weighing between 18 and 68 kg (40 to 150 lb).** Units of equipment weighing between 18 kg (40 lb) and 68 kg (150 lb) shall have handles that provide easy handling of the unit by two or more people. If the unit is very large, it shall have lifting eyes (see Paragraph 4.2.10.1). [Source: AFSC DH 1-3, 1980; UCRL-15673, 1985]
- **4.2.5.1.5 Force limits.** The force exerted pulling or pushing a handle or grasp area shall not exceed the values given in Exhibit 4.2.5.1.5 for the appropriate elbow angle. The values provided in the Exhibit shall be reduced by 30% if the work is performed in excess of 30 minutes. The values given are projected to a mixed male and female population by taking two-thirds of the values for a male population. For a more detailed coverage of pulling and pushing limits, see Snook & Ciriello (1991). [Source: MIL-STD-1472F, 1999]

Exhibit 4.2.5.1.5 Maximum force limits for pulling and pushing units of equipment using handles or grasp areas.

Degree of elbow flexion	Pulling		Pushing	
	Left arm N (lbf)	Right arm N (lbf)	Left arm N (lbf)	Right arm N (lbf)
180	148 (33)	154 (35)	125 (28)	148 (33)
150	125 (28)	166 (37)	89 (20)	125 (28)
120	101 (23)	125 (28)	77 (17)	107 (24)
90	95 (21)	110 (25)	65 (15)	107 (24)
60	77 (17)	71 (16)	65 (15)	101 (23)

4.2.5.2 Handle characteristics

- **4.2.5.2.1 Handle comfort.** Handles shall be comfortable and easy to grasp; they shall not cut into the hand or cause undue pressure on the fingers. [Source: AFSC DH 1-3, 1980; MIL-HDBK-759B, 1992; UCRL-15673, 1985]
- **4.2.5.2.2 Handle surface.** The surface of handles shall be sufficiently hard that grit and grime do not become embedded during normal use. [Source: MIL-STD-1472F, 1999]



- **4.2.5.2.3 Handle conductivity.** The handle material that comes into contact with a user's hand shall not conduct heat or electricity. [Source: MIL-STD-1472F, 1999]
- **4.2.5.2.4 Handle attachment.** Handles shall be permanently attached to the unit of equipment. [Source: MIL-HDBK-759B, 1992]
- **4.2.5.2.5 Stops for hinged or folding handles.** Hinged or folding handles shall have a stop that holds them perpendicular to the surface on which they are mounted when they are moved into carrying position. It shall require only one hand to move them into this position. [Source: AFSC DH 1-3, 1980; MIL-STD-1800A, 1990; MIL-STD-1472F, 1999]

4.2.5.3 Dimensions

The dimensions of handles depend primarily upon the type of handle, the weight of the unit of equipment, and the type of hand covering the user wears (none, gloves, or mittens). Other factors affecting handle dimensions include the normal operating position of the unit, the frequency and distance it is lifted or carried, and whether or not the handle has an additional purpose, such as protecting the front of the equipment or serving as a stand when the equipment is in its maintenance position. [Source: MIL-HDBK-759B, 1992]

- **4.2.5.3.1 Minimum handle dimensions by type of handle and hand covering.** Handles shall equal or exceed the dimensions in Exhibit 4.2.5.3.1 for the appropriate type of handle and the user's hand covering. [Source: MIL-HDBK-759B, 1992; MIL-STD-1472F, 1999; UCRL-15673, 1985]

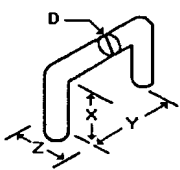
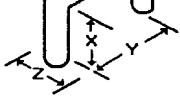
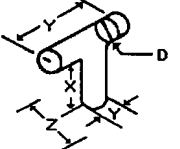
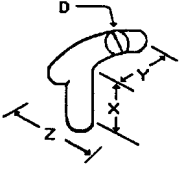
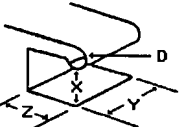
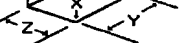
Exhibit 4.2.5.3.1 Minimum handle dimensions

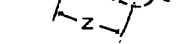
Type of handle		Bare hand			Gloved hand			Mittened hand		
		X	Y	Z	X	Y	Z	X	Y	Z
Two-finger bar	mm (in)	32 (1.25)	65 (2.50)	75 (3.0)	38 (1.5)	75 (3.0)	75 (3.0)	N/A N/A		
 One-hand bar	mm (in)	48 (1.88)	111 (4.37)	75 (3.0)	50 (2.0)	125 (5.0)	100 (4.0)	75 (3.0)	135 (5.25)	150 (6.0)
 Two-hand bar	mm (in)	48 (1.88)	215 (8.5)	75 (3.0)	50 (2.0)	270 (10.5)	100 (4.0)	75 (3.0)	280 (11.0)	150 (6.0)
 T-bar	mm (in)	38 (1.5)	100 (4.0)	75 (3.0)	50 (2.0)	115 (4.5)	100 (4.0)	N/A N/A		
 J-bar	mm (in)	50 (2.0)	100 (4.0)	75 (3.0)	50 (2.0)	115 (4.5)	100 (4.0)	75 (3.0)	125 (5.0)	150 (6.0)
 Two-finger recess	mm (in)	32 (1.25)	65 (2.5)	50 (2.0)	38 (1.5)	75 (3.0)	50 (2.0)	N/A N/A		
 One-hand recess	mm (in)	50 (2.0)	110 (4.25)	90 (3.5)	90 (3.5)	135 (5.25)	100 (4.0)	90 (3.5)	135 (5.25)	125 (5.0)
 Finger-tip recess	mm (in)	19 (0.75)	-	13 (0.5)	25 (1.0)	-	19 (0.75)	N/A N/A		
 One-finger recess	mm (in)	32 (1.25)	-	50 (2.0)	38 (1.5)	-	50 (2.0)	N/A N/A		

- **4.2.5.3.2 Minimum handle diameter by weight of unit of equipment.** Heavier units require handles of greater diameter. The diameter of the handle shall equal or exceed the value given in Exhibit 4.2.5.3.2 for the appropriate weight range. [Source: AFSC DH 1-3, 1980; MIL-STD-1472F, 1999]

Exhibit 4.2.5.3.2 Minimum handle diameter required by weight of unit of equipment

Weight	Diameter
Up to 6.8 kg: (15 lb)	6 mm: (¼ in)
6.8 to 9.1 kg: (15 to 20 lb)	13 mm: (½ in)
9.1 to 18.1 kg: (20 to 40 lb)	19 mm: (¾ in)
Over 18.1 kg: (40 lb)	25 mm: (1 in)

- **4.2.5.3.3 Finger curl.** The size and shape of a handle shall allow the user's fingers to curl around the handle at least 120°. [Source: MIL-STD-1472F, 1999]

4.2.5.4 Location

The location of handles with respect to the center of gravity of a unit of equipment determines the tendency of the unit to tip or sway when it is lifted or carried. Placing the handles above the center of gravity and placing pairs of handles on opposite sides of the unit on a line passing through the center of gravity horizontally ensure the stability of the unit. However, other considerations may outweigh these "balance" considerations. For example, if a unit is intended to be pulled out of a rack, its handles will probably be located on the front of the unit.

- **4.2.5.4.1 Single handles.** A single handle should be located directly above the center of gravity of a unit of equipment. [Source: MIL-STD-1472F, 1999; UCRL-15673, 1985]
- **4.2.5.4.2 Pairs of handles.** The two handles of a pair of handles should be located on opposite sides of the unit of equipment on or above a line passing horizontally through the unit's center of gravity. [Source: MIL-STD-1472F, 1999; UCRL-15673, 1985]
- **4.2.5.4.3 Exposure to hazards.** Handles shall be located so that their use does not expose a user to thermal or electrical hazards. [Source: MIL-STD-1800A, 1990]

- **4.2.5.4.4 Structural clearance.** Handles shall be located to provide a clearance of at least 50 mm (2 in) between the handle and any obstruction when the equipment is in its installed or maintenance position. [Source: MIL-STD-1472F, 1999]

4.2.6 Grasp areas

- **4.2.6.1 Location of grasp area.** Grasp areas should be located above the center of gravity of a unit of equipment so that the unit does not tend to tip or sway when it is lifted or carried. [Source: MIL-STD-1472F, 1999; MIL-STD-1800A, 1990]
- **4.2.6.2 Grasp area finish.** Grasp areas shall have a nonslip finish. If the bottom of a unit of equipment is designed to serve as a grasp area, the bottom surface shall have a nonslip finish. [Source: AFSC DH 1-3, 1980; MIL-STD-1472F, 1999; MIL-STD-1800A, 1990]
- **4.2.6.3 Grasp area material.** The material used for the grasp area shall be sufficiently hard that grit and grime do not become embedded in it during normal use. [Source: MIL-STD-1472F, 1999; MIL-STD-1800A, 1990]
- **4.2.6.4 Grasp area conductivity.** Grasp area material shall not conduct heat or electricity. [Source: MIL-STD-1472F, 1999]

4.2.7 Stands and rests

If a unit of equipment contains components that could be damaged easily during maintenance, stands or rests might be provided to protect the susceptible parts. If the unit has handles, the handles can be designed to serve as the stands or rests.

- **4.2.7.1 Prevention of damage.** If appropriate and practical, units of equipment that contain components that are susceptible to damage shall have stands or rests that protect the susceptible components when the unit is in its maintenance position. [Source: AFSC DH 1-3, 1980; MIL-STD-1472F, 1999; MIL-STD-1800A, 1990]
- **4.2.7.2 Integral to chassis.** When provided, stands or rests shall be part of the basic chassis of the unit of equipment. [Source: AFSC DH 1-3, 1980; MIL-STD-1472F, 1999; MIL-STD-1800A, 1990]
- **4.2.7.3 Handles as stands or rests.** If a unit of equipment requiring stands or rests has handles, the handles should be designed to serve as the stands or rests. [Source: AFSC DH 1-3, 1980]

4.2.8 Alignment aids

Ideally, it would be impossible to install equipment incorrectly. Alignment aids can help to achieve correct installation. The emphasis in this section is on physical devices, such as guides and pins, but labels can also serve as alignment aids.

- **4.2.8.1 Guides, tracks, and stops.** Guides, tracks, and stops shall be provided wherever appropriate to facilitate handling and to prevent damage to equipment and injury to users. [Source: MIL-STD-1472F, 1999]
- **4.2.8.2 Prevention of improper mounting.** Units of equipment shall include physical features (such as supports, guides, or alignment pins) that prevent improper mounting. [Source: AFSC DH 1-3, 1980; MIL-HDBK-759B, 1992; MIL-STD-1472F, 1999; MIL-STD-1800A, 1990; NASA-STD-3000A, 1989]
- **4.2.8.3 Alignment of light-weight units of equipment.** Units of equipment weighing less than 9 kg (20 lb) should have bottom-mounted alignment pins. [Source: MIL-HDBK-759B, 1992]
- **4.2.8.4 Alignment of heavy units of equipment.** Units of equipment weighing more than 9 kg (20 lb) should have side-aligning guides so that the unit can be slid into place. [Source: MIL-HDBK-759B, 1992]
- **4.2.8.5 Labeling units of equipment.** Units of equipment shall have labels that identify their proper alignment, unless the alignment is immediately obvious. [Source: MIL-STD-1472F, 1999]
- **4.2.8.6 Labeling insertion holes.** If a unit of equipment has holes through which connectors or other objects that require proper alignment are inserted, the holes shall have labels showing proper alignment of the object to be inserted. [Source: AFSC DH 1-3, 1980; UCRL-15673, 1985]

4.2.9 Designing for remote handling

- **4.2.9.1 Alignment aids.** All units of equipment designed for remote handling shall have alignment aids. [Source: MIL-STD-1800A, 1990]
- **4.2.9.2 Quick-action connectors.** All connectors on units of equipment designed for remote handling shall be of the quick-action type. [Source: MIL-STD-1800A, 1990]
- **4.2.9.3 Fasteners.** All fasteners on units of equipment designed for remote handling shall be of the captive type and shall be operable by remote handling techniques. [Source: MIL-STD-1800A, 1990]

- **4.2.9.4 Latches.** All latches on units of equipment designed for remote handling shall: (a) be operable from a single point, (b) have positive catches, and (c) provide a clear visual indication of the latch position. [Source: MIL-STD-1800A, 1990]

4.2.10 Designing for use of hoists, jacks, and cranes

- **4.2.10.1 Location of assistance points.** The lifting eyes or jacking points shall be located so that the unit of equipment does not tilt or swing uncontrollably while it is being lifted. [Source: MIL-STD-1472F, 1999]
- **4.2.10.2 Labeling.** Lifting eyes and jacking points shall be labeled conspicuously. [Source: MIL-HDBK-759B, 1992; MIL-STD-1800A, 1990]

4.3 Packaging, arrangement, and mounting of equipment

Equipment can be packaged, arranged, and mounted in a variety of ways. This section gives rules to narrow the choices. Several goals and principles underlie the requirements and rules of this section. They include:

- a. avoiding irregular, fragile, or awkward extensions to equipment, or, if they cannot be avoided, ensuring that such extensions are easy to remove,
- b. packaging equipment so that it can be handled by one person or as few people as possible,
- c. arranging different units of equipment so that maintenance by one specialist does not require moving or handling equipment maintained by another specialist,
- d. mounting equipment so that it is easily installed or removed and readily accessible for maintenance,
- e. mounting equipment in a way that minimizes the need for the user to bend, stretch, crawl, assume awkward positions, or move from place to place in performing maintenance tasks, and
- f. minimizing the need for tools, particularly specialized tools.

4.3.1 Unitization of equipment

Unitization is the packaging of equipment in physically and functionally distinct units that can be easily removed and replaced. This sort of separation can have a number of advantages, such as providing easy access to malfunctioning equipment, allowing a high degree of standardization, simplifying and speeding equipment design by using previously developed standardized designs, and reducing the skill and training requirements for users.

Definitions. A **unit of equipment** is an assemblage of items that may include modules, components, and parts that are packaged together into a single hardware package. For example, a computer, its keyboard, and its visual display are all units of equipment, as are radio transmitters and receivers. A **module** is an assemblage of two or more interconnected parts or components that comprise a single, physical and functional entity. It is this singular functionality that defines a module. A **component** is a subdivision of a unit of equipment that can be treated as an object by the user, but which can be further broken down into parts. A mounting board together with its mounted parts is an example of a component. A **part** is an object that cannot normally be broken down further without destroying its designated use. Fuses, resistors, and capacitors are examples of parts. The **packaging** of a unit of equipment is the assembling, mounting, and enclosing of the items it includes.

- **4.3.1.1 Functional independence.** Units of equipment shall correspond to the functional design of the equipment and shall maximize the functional independence of each unit while minimizing the interaction between units (see Paragraph 4.1.2.5). [Source: UCRL-15673, 1985]
- **4.3.1.2 Packaging equipment.** Whenever possible, units of equipment shall be independent, interchangeable, and easy to replace. [Source: AFSC DH 1-3, 1980; MIL-STD-1472F, 1999; UCRL-15673, 1985]
- **4.3.1.3 Ease of installation.** All equipment shall be easy to mount and easy to connect to other equipment. [Source: MIL-HDBK-759B, 1992]
- **4.3.1.4 Independent adjustment.** Units of equipment shall be capable of being checked and adjusted separately; when interconnected with other units, they shall require little or no additional adjustment. [Source: AFSC DH 1-3, 1980; UCRL-15673, 1985]
- **4.3.1.5 Handling by one person.** Units of equipment should be installable and removable by one person (see Paragraph 4.2.2 on weight limits). [Source: UCRL-15673, 1985]

- **4.3.1.6 Interconnectivity.** The number of inputs and outputs associated with a unit of equipment shall be minimized. [Source: AFSC DH 1-3, 1980]
- **4.3.1.7 Protrusions.** Any irregular protrusions on a unit of equipment, such as cables, waveguides, or hoses shall be easily removable to prevent damage during installation and maintenance. [Source: AFSC DH 1-3, 1980]
- **4.3.1.8 Prevention of incorrect mounting.** Units of equipment should be designed so that they cannot be mounted incorrectly. [Source: MIL-HDBK-759B, 1992]

4.3.2 Interchangeability, non-interchangeability

Units of equipment may be interchangeable physically, functionally, or both. This section contains rules that might be summarized in the general statements that if two units of equipment are interchangeable functionally, they will also be interchangeable physically; if they are not interchangeable functionally, they will not be interchangeable physically.

- **4.3.2.1 Interchangeability of equivalent units of equipment.** Units of equipment having the same form and function shall be interchangeable throughout a system and related systems. [Source: UCRL-15673, 1985]
- **4.3.2.2 Identifiable interchangeable units of equipment.** Interchangeable units of equipment shall be clearly identifiable and easily distinguishable from units that are similar, but not interchangeable. Identification methods might be physical (such as size, shape, and mounting provisions), visual (such as color-coding), or verbal (such as labeling). [Source: MIL-STD-1472F, 1999]
- **4.3.2.3 Non-interchangeability of nonequivalent units of equipment.** Units of equipment that are not functionally interchangeable shall not be physically interchangeable. [Source: MIL-STD-1472F, 1999; UCRL-15673, 1985]
- **4.3.2.4 Identifiable non-interchangeable units of equipment.** Non-interchangeable units of equipment shall be clearly identifiable and readily distinguishable from units that are interchangeable. Identification methods might be physical (such as size, shape, and mounting provisions), visual (such as color-coding), or verbal (such as labeling). [Source: UCRL-15673, 1985]

4.3.3 Mounting in drawers, on racks, and on hinges

4.3.3.1 General

- **4.3.3.1.1 Mounting frequently-moved units of equipment.** Units of equipment that must be moved frequently from their installed positions for maintenance shall be mounted in drawers, on sliding racks, or on hinges. [Source: AFSC DH 1-3, 1980; MIL-STD-1472F, 1999]
- **4.3.3.1.2 Mounting of heavy units of equipment.** Heavy, relatively inaccessible units of equipment that must be inspected or maintained shall be mounted in drawers, on sliding racks, or equipment covers on hinges. [Source: MIL-HDBK-759B, 1992]
- **4.3.3.1.3 Access to rear or bottom of units of equipment.** If the maintainer must have access to the rear or bottom of units of equipment mounted in drawers, on sliding racks, or equipment covers on hinges, the units shall open or rotate fully and remain in that position (held by braces, for example) without being supported by the maintainer. [Source: AFSC DH 1-3, 1980; MIL-HDBK-759B, 1992; MIL-STD-1800A, 1990]
- **4.3.3.1.4 Avoidance of instability.** If opening or extending a unit of equipment that is mounted in a drawer, on a sliding rack, or on hinges would shift the center of gravity of the mounting structure so that it becomes unstable, the structure shall be securely fastened. [Source: MIL-STD-1472F, 1999; MIL-STD-1800A, 1990]
- **4.3.3.1.5 Attachment of equipment.** Units of equipment mounted in drawers, on sliding racks, or on hinges should be attached only to the drawer, rack, or hinge and to interconnecting lines and cables. [Source: UCRL-15673, 1985]
- **4.3.3.1.6 Ease of moving mounted units of equipment.** When units of equipment are mounted in drawers, on sliding racks, or on hinges, the drawers, racks, or hinges shall be easy (require few operations) to open or extend. [Source: UCRL-15673, 1985]
- **4.3.3.1.7 Maximum force to move mounted units of equipment.** The force needed to open or rotate a drawer, slide, or hinged mount shall not exceed the values given in Paragraph 4.2.5.1.5. [Source: UCRL-15673, 1985]
- **4.3.3.1.8 Guards and shields.** If needed to protect fragile or sensitive components, drawers and racks should include guards or shields. [Source: UCRL-15673, 1985]

4.3.3.2 Restraints and supports

Equipment mounted in drawers, on sliding racks, or on hinges must be protected with stops or supports that prevent it from falling or tipping over and that hold it in position both for operation and for maintenance. These stops and supports must be easily overridden so that the equipment can be easily removed and replaced.

- **4.3.3.2.1 Limit stops.** Limit stops shall be provided on all drawer, slide, or hinge mounted equipment that must be moved from its operating position to a maintenance position. [Source: AFSC DH 1-3, 1980; MIL-HDBK-759B, 1992; MIL-STD-1472F, 1999; MIL-STD-1800A, 1990; NASA-STD-3000A, 1989]

Definition. Limit stops are mechanisms that restrict a moving object or part by stopping it at predetermined (limit) positions. [Source: AFSC DH 1-3, 1980; MIL-HDBK-759B, 1992; MIL-STD-1472F, 1999; MIL-STD-1800A, 1990; NASA-STD-3000A, 1989]

- **4.3.3.2.2 Automatic locks.** Drawers and slides shall lock automatically in both the operating and maintenance positions. [Source: MIL-STD-1472F, 1999; UCRL-15673, 1985]
- **4.3.3.2.3 Lock release.** The locks holding drawers and slides in the operating and maintenance positions shall be easy to release, preferably requiring only one hand to operate. [Source: AFSC DH 1-3, 1980; MIL-STD-1472F, 1999; MIL-STD-1800A, 1990; NASA-STD-3000A, 1989]
- **4.3.3.2.4 Supports for hinge-mounted equipment.** Hinge-mounted equipment shall have a means of support to hold it in both the operating and maintenance positions. [Source: AFSC DH 1-3, 1980; MIL-STD-1472F, 1999; MIL-STD-1800A, 1990]

4.3.3.3 External connectors and interlocks

- **4.3.3.3.1 Preservation of external connections.** If external connections are required for maintenance as well as for normal operation, mounting shall be designed so that these connections are not broken when the unit of equipment is slid or rotated into its maintenance position. [Source: UCRL-15673, 1985]
- **4.3.3.3.2 Breaking of external connections.** If it is required that external connections be broken for maintenance, interlocks shall be provided that break the connections when the equipment is slid or rotated into its maintenance position. [Source: MIL-STD-1472F, 1999; MIL-STD-1800A, 1990]
- **4.3.3.3.3 External connectors as part of supporting structure.** If equipment mounted in a drawer or on a sliding rack is intended to be removed and replaced by users, and if external connections are not required during maintenance, the drawer or rack shall be provided with connectors on the rear of the equipment that mate with connectors mounted on the structure. [Source: MIL-STD-1472F, 1999]

4.3.4 Positioning equipment

Some general considerations affecting the positioning of equipment are:

- a. Avoid locations where the equipment or the user would be exposed to damage or injury.
- b. Avoid locations where the equipment or the user would be exposed to oil, dirt, or other contaminants.
- c. Choose the most accessible locations for the most frequently serviced equipment.
- d. Choose the most accessible locations for the heaviest or bulkiest equipment.
- e. Choose the most protected locations for the most fragile or sensitive equipment.

4.3.4.1 Physical accessibility

- **4.3.4.1.1 Complete visual and physical access.** Equipment shall be positioned so that the maintainer has complete visual and physical access to all parts of the equipment on which maintenance is performed; this includes access openings, adjustment points, test points, cables, connectors, labels, and mounting fasteners. [Source: MIL-HDBK-759B, 1992; MIL-STD-1472F, 1999; MIL-STD-1800A, 1990; NASA-STD-3000A, 1989]
- **4.3.4.1.2 Freedom from structural obstruction.** Units of equipment shall be positioned so that neither visual nor physical access is obstructed by structural members or permanently installed equipment. [Source: MIL-HDBK-759B, 1992; MIL-STD-1472F, 1999; MIL-STD-1800A, 1990; UCRL-15673, 1985]
- **4.3.4.1.3 Working space.** Units of equipment shall be positioned so that there is sufficient space around them for the use of any tools and test equipment required for their maintenance [Source: MIL-HDBK-759B, 1992; MIL-STD-1472F, 1999; NASA-STD-3000A, 1989]
- **4.3.4.1.4 Room to open covers.** Units of equipment shall be positioned with sufficient clearance from other equipment and structures to permit unhindered opening of any covers that are opened during maintenance tasks. [Source: AFSC DH 1-3, 1980]
- **4.3.4.1.5 Stacking or blocking equipment.** Units of equipment shall not be stacked or placed in front of or behind other units; each unit shall be positioned so that it is both visually and physically accessible without the removal of another unit. [Source: AFSC DH 1-3, 1980; MIL-HDBK-759B, 1992; MIL-STD-1800A, 1990; NASA-STD-3000A, 1989; UCRL-15673, 1985]

- **4.3.4.1.6 Full extension or rotation.** Units of equipment mounted in drawers, on sliding racks, or on hinges shall be positioned so that the drawer, rack, or hinge can be opened or extended without hindrance. [Source: MIL-STD-1472F, 1999; NASA-STD-3000A, 1989]
- **4.3.4.1.7 Working level.** Units of equipment should be positioned so that they are at the most favorable working level; this is usually between the maintainer's hip and shoulder height, from approximately 1 to 1.5 m (3 to 5 ft). [Source: AFSC DH 1-3, 1980; MIL-HDBK-759B, 1992; UCRL-15673, 1985]
- **4.3.4.1.8 Visual access.** Units of equipment that require frequent visual inspection shall be positioned so that the components to be inspected (such as displays, test points, and labels) can be seen easily without the removal of any other equipment. [Source: AFSC DH 1-3, 1980; MIL-HDBK-759B, 1992]
- **4.3.4.1.9 Removal path.** Units of equipment intended to be replaceable by maintainers shall be positioned so that they can be removed along a straight or moderately curved path, not along a sharply bent path. [Source: AFSC DH 1-3, 1980; MIL-STD-1472F, 1999]

4.3.4.2 Relative accessibility

In addition to considerations of physical accessibility, the positioning of equipment is affected by its indispensability, the frequency with which it is serviced or maintained, the relationship of one unit of equipment to other units, and the difficulty with which it is serviced or maintained.

- **4.3.4.2.1 Criticality of equipment.** The most critical units of equipment shall be the most accessible. Accessibility may be compromised for highly reliable critical equipment. [Source: MIL-STD-1472F, 1999; NASA-STD-3000A, 1989]
- **4.3.4.2.2 Frequency of access.** If criticality is not a factor, equipment requiring the most frequent servicing or maintenance shall be the most accessible. [Source: AFSC DH 1-3, 1980; MIL-HDBK-759B, 1992; MIL-STD-1472F, 1999; NASA-STD-3000A, 1989; UCRL-15673, 1985]
- **4.3.4.2.3 Grouping to minimize movement.** Units of equipment maintained by the same person shall be positioned near each other (provided the operational grouping of equipment remains in close proximity) to minimize the amount of movement required of the maintainer. [Source: AFSC DH 1-3, 1980; MIL-HDBK-759B, 1992; MIL-STD-1472F, 1999]
- **4.3.4.2.4 Non-interaction with equipment maintained by others.** Access to units of equipment maintained by one type of maintenance specialist shall not require moving equipment maintained by another type of specialist. When conflicts with Paragraphs 4.3.4.2.1 through 4.3.4.2.3 occur, the previous paragraphs shall have priority. [Source: MIL-STD-1472F, 1999; MIL-STD-1800A, 1990]

- **4.3.4.2.5 Difficulty of moving.** Units of equipment that are difficult to move shall not prevent convenient access to other units. [Source: MIL-STD-1472F, 1999; MIL-STD-1800A, 1990]
- **4.3.4.2.6 Non-interaction with equipment not in need of maintenance.** It shall not be necessary to remove or disable an operable unit of equipment to obtain access to a unit requiring maintenance. [Source: NASA-STD-3000A, 1989]

4.3.5 Labeling and marking

Labels on equipment can be used to (a) identify the equipment, (b) state warnings or cautions, (c) supply useful information, such as instructions, the weight of the equipment, or calibration information, and (d) record and supply historical data, such as periodic readings or the date of servicing or replacement.

Definitions. A **label** is alphanumeric information that identifies or describes an object. Labels can be printed directly on or adjacent to the object, or they can be printed on a card or plate that is attached to the object or adjacent to the object. **Marking** is nonverbal information, such as colors or symbols, which identifies or describes an object. Marking can appear directly on or adjacent to the object, or it can be printed on a card or plate that is attached to the object or adjacent to the object.

4.3.5.1 Types of labels

- **4.3.5.1.1 Equipment identification.** All units of equipment shall have identifying labels. These labels shall be securely attached, permanent, nonfading, oil-, gasoline-, and corrosion-resistant, and shall include all of the following that are applicable: (a) contract order or task number, (b) equipment name, (c) specification number, (d) manufacturer's part number, (e) serial number, (f) manufacturer's name and address, and (g) if necessary, stock number. [Source: UCRL-15673, 1985]

Discussion. Note that OSHA 29 CFR 1910.303 (e) requires that electrical equipment itself must have a manufacturer's name or trademark or other descriptive material which identifies product responsibility and includes markings giving voltage, current, wattage or other ratings. [Source: 29 CFR 1910.303; UCRL-15673, 1985]

- **4.3.5.1.2 Hazard labels.** If any hazard exists in servicing or maintaining a unit of equipment, the equipment shall have a warning label attached that describes the hazard. [Source: MIL-HDBK-759B, 1992]

Discussion. Electrical equipment that is to be used in hazardous locations must be marked to show the hazardous location class and group (from National Fire Protection Association 70) and operating temperatures. [Source: MIL-HDBK-759B, 1992]

- **4.3.5.1.3 Weight labels.** Weight and center of gravity caution placards shall be placed on any unit of equipment to be moved for maintenance if its weight exceeds 13.6 kg (30 lbs). If it is designed to be lifted or carried by more than one person, the label shall include the number of people recommended to lift or carry it (see Paragraph 4.2.2.10). [Source: MIL-HDBK-759B, 1992; MIL-STD-1800A, 1990]
- **4.3.5.1.4 Instruction labels.** If there are critical instructions for the servicing or maintenance of a unit of equipment, and if these instructions are not likely to be available through other means, they shall be provided in a label on the equipment. [Source: UCRL-15673, 1985]
- **4.3.5.1.5 Data labels.** If there are critical data that must be available to or recorded by the maintainer of a unit of equipment, and if there is no other provision for them, a label shall be provided for these data. [Source: UCRL-15673, 1985]

4.3.5.2 Location and orientation

- **4.3.5.2.1 Readability.** Equipment labels shall be located so that they are visible and readable with the equipment in its installed position. [Source: UCRL-15673, 1985]
- **4.3.5.2.2 Preserving readability.** Equipment labels shall be located so that they will not become obscured by dirt, moisture, or other foreign materials. If these materials are likely to accumulate, the labels shall be mounted on a vertical surface. [Source: UCRL-15673, 1985]
- **4.3.5.2.3 Consistent location.** Labels on similar units of equipment should be placed in approximately the same location on each. [Source: UCRL-15673, 1985]
- **4.3.5.2.4 Horizontal orientation.** Labels shall be oriented so that alphanumeric characters are read horizontally, not vertically. [Source: UCRL-15673, 1985]

4.3.5.3 Typographic matters

- **4.3.5.3.1 Character height for viewing distance.** Unless circumstances require otherwise, labels shall be clearly legible at a viewing distance of 710 mm (28 in). The recommended height for letters and numerals at this distance is approximately 5 mm (.18 in). Exhibit 4.3.5.3.1 gives minimum character heights for other viewing distances. [Source: UCRL-15673, 1985]

Exhibit 4.3.5.3.1 Minimum character height for various viewing distances

<u>Viewing distance</u>	<u>Minimum height</u>
Less than 0.5 m (20 in)	2.3 mm (0.1 in)
0.5 - 1.0 m (20 - 40 in)	4.7 mm (0.2 in)
1.0 - 2.0 m (40 - 80 in)	9.4 mm (0.4 in)
2.0 - 4.0 m (80 - 160 in)	18 mm (0.75 in)

- **4.3.5.3.2 Stroke width in normal illumination.** If labels are expected to be read under normal illumination, characters shall be black on a white or light background, and stroke width shall be 1/6 to 1/7 of the height. [Source: UCRL-15673, 1985]
- **4.3.5.3.3 Stroke width in dim illumination.** If labels are expected to be read under dim illumination, characters shall be white on a black or dark background, and stroke width shall be from 1/7 to 1/8 of the height. [Source: UCRL-15673, 1985]
- **4.3.5.3.4 Width to height ratios.** The width to height ratio of letters and numerals shall be 3:5 with the exceptions of "M" and "W," which shall be 4:5, "4," which shall be one stroke width wider, and "I" and "1," which shall be one stroke wide. [Source: UCRL-15673, 1985]
- **4.3.5.3.5 Character spacing.** The spacing between characters shall be at least one stroke width. [Source: UCRL-15673, 1985]
- **4.3.5.3.6 Word spacing.** The spacing between words shall be approximately the width of one normal-width character. [Source: UCRL-15673, 1985]
- **4.3.5.3.7 Line spacing.** The spacing between lines shall be at least one-half the character height. [Source: UCRL-15673, 1985]
- **4.3.5.3.8 Case of letters.** If the text on a label is exclusively single words, such as names, the words shall appear as all capital letters; if the text is phrases or sentences, the text shall appear as mixed case letters. [Source: UCRL-15673, 1985]

- **4.3.5.3.9 Text and background combinations.** Text and background combinations shall provide sufficient contrast to ensure legibility. Black characters may appear on white, yellow, light gray, matte-finished brass or aluminum, or any bright plated backgrounds; white characters may appear on dark backgrounds; other acceptable combinations are blue on white, green on white, green on red, and red on yellow. [Source: UCRL-15673, 1985]

4.3.5.4 Wording

- **4.3.5.4.1 Consistency.** Designations and terms used on labels shall be consistent with designations and terms in user documentation and parts catalogs. [Source: UCRL-15673, 1985]
- **4.3.5.4.2 Wording.** The wording of labels should be brief but explanatory, using words that are familiar to maintainers. Abbreviations and abstract terms should be used only if it can be reasonably expected that they will be known to all maintainers. [Source: UCRL-15673, 1985]
- **4.3.5.4.3 Instructions.** Labels containing a series of steps to be carried out should list the steps, not present them in paragraph form. [Source: UCRL-15673, 1985]

4.3.5.5 Markings

- **4.3.5.5.1 Number of color codes.** If color-coding is used, the number of different colors shall not exceed nine. [Source: UCRL-15673, 1985]
- **4.3.5.5.2 Recommended colors.** If color-coding is used, the colors shall be distinguishable by both color-normal and color-deficient persons. Colors meeting this criterion are given in Exhibit 4.3.5.5.2. [Source: UCRL-15673, 1985]

Exhibit 4.3.5.5.2 Recommended colors

<u>Color</u>	<u>Spec No*</u>
Red	1110
Orange	1210
Yellow	1310
Blue	10B 7/6
Purple	2715
Gray	1625
Buff	1745
White	1755
Black	1770

* From Fed. Spec. II-C-595 except for blue, which is from Munsell (1942)

- **4.3.5.5.3 Arrows.** Arrows used in labels or markings should be clearly recognizable and easily identifiable from a distance. Sharp angles and a tapered overall shape are preferable to wide angles and a relatively uniform overall shape (see Exhibit 4.3.5.5.3). [Source: UCRL-15673, 1985]

Exhibit 4.3.5.5.3 Good and bad arrows

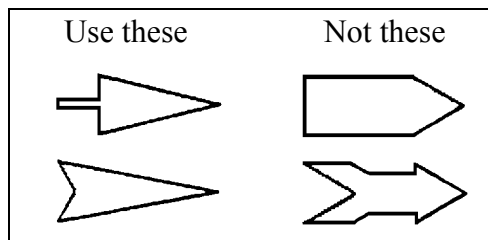

4.4 Access openings

This section contains rules for access openings, that is, openings in a case, cover, panel, or door through which a maintainer requires visual or physical access or both, to perform maintenance tasks. Rules are given for properties of the openings, how to ensure both visual and physical access, the size, shape, and location of the openings, and their labeling. Rules regarding covers for access openings are given in Section 4.5.

4.4.1 General

- **4.4.1.1 When an access opening is required.** An access opening shall be provided whenever a maintenance task would otherwise require removing a case or covering, opening a fitting, or dismantling a unit. [Source: AFSC DH 1-3, 1980; MIL-STD-1472F, 1999; MIL-STD-1800A, 1990; UCRL-15673, 1985]
- **4.4.1.2 Number of openings.** One large opening should be provided rather than several small ones. [Source: NASA-STD-3000A, 1989; UCRL-15673, 1985]
- **4.4.1.3 Prevention of injury or damage.** The edges of access openings shall be either (a) sufficiently rounded and smoothly finished or (b) covered or coated sufficiently to prevent injury to the maintainer's person, clothing, and equipment. [Source: AFSC DH 1-3, 1980; MIL-HDBK-759B, 1992; MIL-STD-1472F, 1999; MIL-STD-1800A, 1990; NASA-STD-3000A, 1989]
- **4.4.1.4 Uncovered openings.** When environmental, operational, and safety conditions permit, openings should be left uncovered. [Source: MIL-HDBK-759B, 1992; MIL-STD-1472F, 1999; UCRL-15673, 1985]
- **4.4.1.5 Unacceptability of rivets.** Riveted panels or doors shall not be used to cover access openings. Quick-action fasteners shall be used except in cases when the panel or door is subjected to stress or pressure, in which case screws shall be used. [Source: MIL-HDBK-759B, 1992]

4.4.2 Access



- **4.4.2.1 Visual and physical access.** If a maintainer must see what he or she is doing inside the opening, then either the opening shall be large enough and positioned so that the maintainer has the necessary view, or separate openings shall be provided for visual and physical access. [Source: MIL-HDBK-759B, 1992; MIL-STD-1472F, 1999; MIL-STD-1800A, 1990; NASA-STD-3000A, 1989; UCRL-15673, 1985]

- **4.4.2.2 Visual access only.** If a maintenance task requires only visual access, the access opening should be designed and positioned so that the maintainer can see whatever is needed without removing panels or other components. Such openings should not compromise personnel safety. [Source: MIL-HDBK-759B, 1992; UCRL-15673, 1985]
- **4.4.2.3 Physical access only.** Physical access without visual access, that is, access in which the maintainer cannot see what he or she is doing inside an access opening, shall not be provided without approval of the acquisition program office. [Source: MIL-STD-1472F, 1999]

4.4.3 Size







- **4.4.3.1 Accommodation.** An access opening shall be large enough to accommodate whatever combination of components, tools, body parts, clothing, and movements is required to perform the task. [Source: MIL-STD-1472F, 1999]
- **4.4.3.2 Dimensions for one- or two-finger access.** Dimensions of openings intended to allow access by one or two fingers shall equal or exceed those given in Exhibit 4.4.3.2. [Source: MIL-STD-1472F, 1999]

Exhibit 4.4.3.2 Minimum dimensions of openings designed for access by one or two fingers without visual access [Source: MIL-STD-1472F, 1999; AFSC DH 1-3, 1980]

	Action	Bare hand mm (in)	Gloved hand mm (in)
	Push button	32 (1.25)	38 (1.5)
	Turn knob having diameter X	X + 50 (2.0)	X + 65 (2.5)

- 4.4.3.3 **Dimensions for one hand or arm access.** Dimensions for openings intended to allow access by one hand or one arm shall equal or exceed those given in Exhibit 4.4.3.3. [Source: MIL-STD-1472F, 1999; AFSC DH 1-3, 1980]

Exhibit 4.4.3.3 Minimum dimensions of openings designed for access by one hand or arm without visual access.

	Height mm (in)	Width mm (in)	Diameter mm (in)
Empty hand, to wrist			
	Bare hand, flat 55 (2.25)	100 (4.0)	100 (4.0)
	Bare hand, rolled 95 (3.75)	95 (3.75)	95 (3.75)
	Glove or mitten 100 (4.0)	150 (6.0)	150 (6.0)
	Arctic mitten 125 (5.0)	165 (6.5)	165 (6.5)
Clenched hand, to wrist			
	Bare hand 5 (3.75)	125 (5.0)	125 (5.0)
	Glove or mitten 115 (4.5)	150 (6.0)	150 (6.0)
	Arctic mitten 180 (7.0)	215 (8.5)	215 (8.5)
Hand plus 25 mm object, to wrist			
	Bare hand 95 (3.75)	95 (3.75)	95 (3.75)
	Glove or mitten 150 (6.0)	150 (6.0)	150 (6.0)
	Arctic mitten 180 (7.0)	180 (7.0)	180 (7.0)
Hand plus X mm object, to wrist			
	Bare hand	X + 45 (1.75) clearance around object	
	Glove or mitten	X + 65 (2.5) clearance around object	
	Arctic mitten	X + 90 (3.5) clearance around object	
Arm to elbow			
	Light clothing 100 (4.0)	115 (4.5)	115 (4.5)
	Arctic clothing 180 (7.0)	180 (7.0)	180 (7.0)
	With object	Same clearances as hand plus object	
Arm to shoulder			
	Light clothing 125 (5.0)	125 (5.0)	125 (5.0)
	Arctic clothing 215 (8.5)	215 (8.5)	215 (8.5)
	With object	Same clearances as hand plus object	

- 4.4.3.4 Dimensions for two-hand access.** Dimensions of openings intended to allow access by two hands shall equal or exceed those given in Exhibit 4.4.3.4. [Source: MIL-STD-1472F, 1999; AFSC DH 1-3, 1980]

Exhibit 4.4.3.4 Minimum dimensions of openings designed for access by two hands without visual access

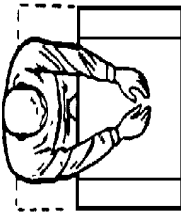
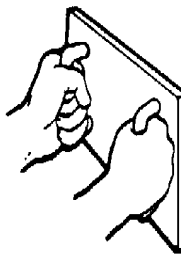
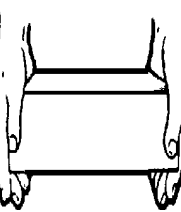
	<p><u>Reaching with both hands to depth of 150 to 500 mm (6 to 20 in):</u></p>
	<p><u>Light clothing:</u> Width: 200 mm (8 in) or depth of reach* Height: 125 mm (5 in)</p>
	<p><u>Arctic clothing:</u> Width: 150 mm (6 in) plus $\frac{3}{4}$ the depth of reach Height: 180 mm (7 in)</p>
	<p><u>Reaching full arm's length (to shoulders) with both arms:</u></p>
	<p>Width: 500 mm (20 in) Height: 125 mm (5 in)</p>
	<p><u>Inserting box grasped by handles on front:</u></p>
	<p>13 mm ($\frac{1}{2}$ in) clearance around box, assuming adequate clearance around handles</p>
	<p><u>Inserting box with hands on the sides:</u></p>
	<p><u>Light clothing:</u> Width: Box plus 115 mm ($4\frac{1}{2}$ in) Height: 125 mm (5 in) or 13 mm ($\frac{1}{2}$ in) around box*</p>
	<p><u>Arctic clothing:</u> Width: Box plus 180 mm (7 in)</p>

4.4.4 Shape

As with size, the shape of an access opening is influenced by (a) the body appendages and equipment that will pass through the opening, (b) the movements the maintainer will perform inside the opening, and (c) the maintainer's need for visual access through the opening. The shape need not be a conventional shape such as a circle or rectangle.

- **4.4.4.1 Shape appropriate to task.** The shape of an access opening shall allow the maintainer to perform those tasks requiring access through the opening. [Source: AFSC DH 1-3, 1980; MIL-HDBK-759B, 1992; MIL-STD-1472F, 1999; NASA-STD-3000A, 1989; UCRL-15673, 1985]

4.4.5 Location

- **4.4.5.1 On accessible surfaces.** Access openings shall be located on equipment surfaces that are accessible when the equipment is in its normal operating position. [Source: MIL-HDBK-759B, 1992; UCRL-15673, 1985]
- **4.4.5.2 Near related displays, controls, and connectors.** Access openings shall be located within easy view and reach of any test points, displays, controls, or connectors that require access in performing a particular maintenance task. [Source: MIL-HDBK-759B, 1992; UCRL-15673, 1985]
- **4.4.5.3 Away from hazards.** Access openings shall be located at a safe distance or shielded from any hazards such as high voltages or dangerous moving parts to which the maintainer might be exposed. [Source: MIL-HDBK-759B, 1992; UCRL-15673, 1985]
- **4.4.5.4 Comfortable for maintainer.** Access openings shall be located so that they do not require undue bending, stretching or other awkward body postures of the maintainer while he or she performs required tasks. [Source: MIL-HDBK-759B, 1992; MIL-STD-1472F, 1999; UCRL-15673, 1985]
- **4.4.5.5 Easy removal of components.** Access openings should be located so that heavy or bulky components can be pulled out rather than lifted out. [Source: MIL-HDBK-759B, 1992; UCRL-15673, 1985]
- **4.4.5.6 Conformance with related items.** If work stands or carts are used in the maintenance tasks, access openings shall conform to the height of the stands or carts. [Source: UCRL-15673, 1985]
- **4.4.5.7 Free of obstructions.** Access openings shall be located so that it is not necessary to remove any components or wires to reach them. [Source: MIL-HDBK-759B, 1992; UCRL-15673, 1985]

- **4.4.5.8 Impervious to environmental conditions.** Access openings shall be located so that environmental conditions such as rain, snow, and ice neither interfere with access nor damage components when the access is open. [Source: MIL-HDBK-759B, 1992]

4.4.6 Labeling and marking

The rules in this section apply only to labeling and marking access openings; if the opening has a cover, the relevant rules are given in Paragraphs 4.5.4 and 4.5.5.

- **4.4.6.1 Identification of opening.** Each access opening shall be labeled with a name, number, letter or other symbol and referred to by that identification in maintenance instructions. [Source: AFSC DH 1-3, 1980; UCRL-15673, 1985]
- **4.4.6.2 Identification of accessible components and maintenance tasks.** Each access opening should be labeled with identifiers for the maintainable components accessible through the opening. This labeling may also include information about equipment to be used in the maintenance tasks and procedural information about the tasks themselves. [Source: AFSC DH 1-3, 1980; MIL-STD-1472F, 1999; UCRL-15673, 1985]
- **4.4.6.3 Warning labels.** If any hazardous condition exists inside an access opening (such as high voltages or dangerous moving parts), the opening shall have a conspicuous warning label advising the maintainer of the hazard and stating any necessary precautions. [Source: AFSC DH 1-3, 1980; MIL-STD-1472F, 1999; UCRL-15673, 1985]

4.5 Cases, covers, guards, and shields

This section contains rules governing the size, mounts, shape, location, fasteners, interlocks, and labels of cases, covers, guards, and shields.

Definitions. A **case** is the part of a unit of equipment that encloses and protects the equipment from its surroundings. It may also serve to protect the surroundings - including users - from the equipment. A **cover** is a part of a unit of equipment that closes an access opening. A **guard** is an enclosure or barrier intended to prevent inadvertent or unauthorized operation of a control. A **shield** is an enclosure or barrier intended to protect components that are susceptible to damage or to protect maintainers from possible injury.

Covers, guards, and shields may take a variety of forms, including (a) hinged doors or caps, (b) sliding doors or caps, (c) removable doors or caps, (d) removable panels, and (e) physical barriers.

Hinged doors and caps allow the fastest and easiest access; they require few fasteners and, depending upon their orientation, may not need support in the open position. They do require "swinging" space, and they may intrude on the user's workspace.

Sliding doors or caps are particularly useful where "swinging" space is limited. They do not generally provide a tight seal.

Removable doors or caps require little space for opening and, once removed, do not interfere with working space. Handling them does take time and effort.

Removable panels can give access to large portions of a unit of equipment. They do not require "swinging" space, but they may be awkward to handle or susceptible to damage.

4.5.1 General

- **4.5.1.1 Fasteners.** Cases and covers should be fastened in accordance with Section 4.6 Fasteners.

- 4.5.1.2 **Preferred type of cover.** The cover of an access opening shall be appropriate to the type of access required and the prevailing environmental conditions as outlined in Exhibit 4.5.1.2. [Source: AFSC DH 1-3, 1980; MIL-STD-1472F, 1999; NASA-STD-3000A, 1989; UCRL-15673, 1985]

Exhibit 4.5.1.2 Type of covering for type of access and environmental conditions

Condition	Physical access	Visual access
No adverse condition	No cover	No cover
Debris, moisture, other foreign material present	Hand-operated, latched, sliding or hinged cap or door, or, less desirable, a removable panel with captive, quick-action fasteners	Transparent plastic window
Subject to wear or contact with solvents		Break-resistant glass window
Stress or pressure requirements	Removeable panel with the smallest number of the largest screws that meet the requirements	Opaque cover plate with the smallest number of the largest screws that meet the requirements

- 4.5.1.3 **Accessibility.** Cases shall be designed so that they can be opened, removed, and replaced without dismantling the equipment or associated equipment and items. [Source: MIL-HDBK-759B, 1992]
- 4.5.1.4 **How to open.** It shall be clear to the user how to open a case or cover, either through a property of the case or cover itself, such as its shape, or by the provision of instructions on or near the case or cover. [Source: AFSC DH 1-3, 1980]
- 4.5.1.5 **Lift case, not equipment.** The case for a unit of equipment shall be designed so that the case is lifted off the equipment, not so that the equipment is lifted out of the case. [Source: AFSC DH 1-3, 1980; MIL-HDBK-759B, 1992; MIL-STD-1472F, 1999]
- 4.5.1.6 **Ease of removal and replacement.** Cases shall be easy to open, remove, and replace. [Source: AFSC DH 1-3, 1980]
- 4.5.1.7 **Accessibility upon opening or removal.** Cases and units of equipment shall be designed so that when a case is opened or removed, all portions of the equipment that are relevant to the user task are accessible. The opened case shall not obscure or interfere with any controls, displays, test points, service points, or connections relevant to the user task. [Source: MIL-HDBK-759B, 1992]

- **4.5.1.8 Minimizing need for removal.** Cases and equipment should be designed to minimize the need to remove the case. [Source: MIL-HDBK-759B, 1992; UCRL-15673, 1985]

Example. Adjustment controls, test points, and service points might be made accessible without requiring opening or removing the case. [Source: MIL-HDBK-759B, 1992; UCRL-15673, 1985]

- **4.5.1.9 Ease of opening.** Cases, covers, and fasteners should be selected or designed so that their combination makes the easiest to remove, open, and close while meeting the closure and structural requirements of the equipment. [Source: AFSC DH 1-3, 1980; UCRL-15673, 1985]

Example. A case or cover that is opened relatively frequently but that does not need to be sealed tightly might be a hinged door with a quick-release latch. [Source: AFSC DH 1-3, 1980; UCRL-15673, 1985]

- **4.5.1.10 Fastened-unfastened indication.** Cases and covers shall be designed or mounted so that it is clear whether or not they are fastened when they are in place. [Source: AFSC DH 1-3, 1980; MIL-STD-1472F, 1999; UCRL-15673, 1985]

Example. Cases and covers might be spring loaded so that they stay open when they are not fastened. [Source: AFSC DH 1-3, 1980; MIL-STD-1472F, 1999; UCRL-15673, 1985]

- **4.5.1.11 Handles or grasp areas.** If a case or cover is heavy or difficult to open, remove, or replace, it shall have one or more handles, grasp areas, lifting eyes, or a combination of these. [Source: MIL-HDBK-759B, 1992; MIL-STD-1472F, 1999; MIL-STD-1800A, 1990; UCRL-15673, 1985]

- **4.5.1.12 Accommodate gloves.** If present, handles and grasp areas shall accommodate any gloves or other special clothing the user might be expected to wear. [Source: MIL-HDBK-759B, 1992; MIL-STD-1472F, 1999; MIL-STD-1800A, 1990; UCRL-15673, 1985]

- **4.5.1.13 Shift in balance of equipment.** Hinged or sliding doors shall not unbalance equipment when they are opened. [Source: MIL-HDBK-759B, 1992]

Discussion. If an imbalance would otherwise result, the case or cover or the equipment might have some sort of prop or support to prevent the unbalance. [Source: MIL-HDBK-759B, 1992]

- **4.5.1.14 Stops and retaining devices.** Attached cases and covers shall have stops or retaining devices that hold them in both the open and closed positions. These stops and retainers shall be appropriate to the ambient environment. [Source: MIL-HDBK-759B, 1992; UCRL-15673, 1985]

Example. An access door on equipment out of doors and subject to wind would need a more secure restraint than one on equipment located indoors. [Source: MIL-HDBK-759B, 1992; UCRL-15673, 1985]

- **4.5.1.15 Ventilation holes.** If a case, cover, or shield requires ventilation holes, the holes shall be small enough to prevent inadvertent insertion of objects that might touch high voltage sources or moving parts. [Source: AFSC DH 1-3, 1980]
- **4.5.1.16 Rounded edges.** The corners and edges of cases and covers shall be smooth or rounded so that they do not injure the user or damage his or her clothing. [Source: AFSC DH 1-3, 1980; MIL-STD-1472F, 1999; UCRL-15673, 1985]
- **4.5.1.17 Small removable covers.** Small removable caps or covers that might be susceptible to dropping or loss, perhaps with resulting damage to components inside the opening, shall be attached to the equipment or structure. [Source: MIL-HDBK-759B, 1992; MIL-STD-1472F, 1999; UCRL-15673, 1985]
- **4.5.1.18 Alignment aids.** If a case is heavy or awkward to handle, or if it encloses delicate, sensitive components, the case or the equipment shall have guide pins, tracks, or some other alignment device to help guide the case while it is being opened, removed, or replaced. [Source: MIL-HDBK-759B, 1992]
- **4.5.1.19 Sealing material.** If the equipment design includes sealing material between the case and the base to which it is attached, the sealing material and its mounting method shall be selected so that the material is not damaged while the case is being opened, removed, or replaced. [Source: AFSC DH 1-3, 1980; MIL-HDBK-759B, 1992]
- **4.5.1.20 Accessible with equipment in installed position.** When maintenance tasks require that a cover be opened with the equipment in its installed position, both the cover and its fasteners shall be located so that they are visually and physically accessible with the equipment in that position. [Source: AFSC DH 1-3, 1980; MIL-STD-1472F, 1999; MIL-STD-1800A, 1990]

4.5.2 Size

- **4.5.2.1 Size of covers.** Cases and covers shall be as small and light in weight as possible while meeting the closure, structural, and ease of maintenance requirements of the equipment. [Source: UCRL-15673, 1985]

Discussion. It is most desirable that covers be openable, removable, and transportable with one hand; next most desirable that they require handling by only one person; least desirable, that they require handling by two or more people. [Source: UCRL-15673, 1985]

- **4.5.2.2 Precise movements not required.** Cases shall be sufficiently larger than the items they cover so that they can be opened, removed, and replaced without requiring precise movements on the part of the user. [Source: MIL-STD-1472F, 1999]

- **4.5.2.3 Clearance between case and components.** Cases shall be large enough that they do not damage internal wiring or components when they are opened, removed, or replaced. [Source: AFSC DH 1-3, 1980; MIL-HDBK-759B, 1992; MIL-STD-1472F, 1999]

4.5.3 Shape

- **4.5.3.1 Appropriate to opening.** The shape of a case or cover shall be appropriate to the opening or item it covers and shall provide the degree of closure required. [Source: MIL-HDBK-759B, 1992]
- **4.5.3.2 Proper orientation.** If a removable access cover requires a particular orientation, the cover shall be designed to prevent attachment in any other orientation. [Source: UCRL-15673, 1985]

Example. This might be accomplished by: (a) giving the cover an asymmetric or irregular shape, (b) including alignment guides or pins, or (c) arranging the holes for fasteners asymmetrically. [Source: UCRL-15673, 1985]

4.5.4 Hinged covers

- **4.5.4.1 Safe operation.** Hinged cases and covers shall be designed so that opening and closing them will not interfere with, damage, or have the potential for harmful contact with wires or other components. [Source: UCRL-15673, 1985]
- **4.5.4.2 Self-supporting.** Hinged cases and covers shall have stops or retainers that hold them in the open position. These stops shall also prevent the case or cover from swinging into or falling on fragile equipment, from swinging into the users themselves, and from springing the hinges. [Source: MIL-HDBK-759B, 1992; MIL-STD-1472F, 1999; NASA-STD-3000A, 1989; UCRL-15673, 1985]
- **4.5.4.3 Operable with one hand.** The user should be able to open and close a hinged case or cover using only one hand. [Source: MIL-STD-1472F, 1999]
- **4.5.4.4 Noninterference of open cover with accessibility.** Hinged and sliding covers shall be located so that when they are open, they do not interfere with access to the openings themselves, or to related controls, displays, test points, and the like. [Source: MIL-HDBK-759B, 1992; MIL-STD-1472F, 1999; UCRL-15673, 1985]

4.5.5 Sliding doors and caps

- **4.5.5.1 Safe operation.** Sliding doors and caps shall be designed so that opening and closing them will not interfere with, damage, or have the potential for harmful contact with wires or other components. [Source: UCRL-15673, 1985]

- **4.5.5.2 Positive locking.** Sliding doors and caps should lock in the closed position, giving the user feedback, perhaps with a "snap" action or an audible click, when they are closed. They should also lock and give feedback in the open position unless they are removed when opened. [Source: UCRL-15673, 1985]
- **4.5.5.3 Non-jamming.** Sliding doors and caps should not bind or jam while being opened or closed. [Source: UCRL-15673, 1985]
- **4.5.5.4 Easy hand operation.** Sliding doors and caps should be easy to open and close without the use of tools. [Source: UCRL-15673, 1985]

4.5.6 Interlocks

Interlocks are distinguished from lockouts and tagouts.

Definitions. **Interlocks** are devices (for example, switches) connected with a cover, shield, or case that disable the associated internal hazard (usually electrical) when the cover, shield, or case is opened. OSHA regulations discuss lockout and tagout procedures to be used in the workplace during maintenance or operations to protect from electrical hazards. A **lockout** uses a mechanical means to disable a control or switch in its safe position (for example, electricity disconnected) and to prevent its activation without the use of undue force or tools. **Tagouts** are tags that are attached to a control or place of hazard to identify the required control condition and hazard associated with an ongoing mode of operation or maintenance.

- **4.5.6.1 Protection from hazards.** If a hazardous condition (such as a high voltage or moving parts) exists inside a case or behind a cover or shield, that cover or shield shall have an interlock that disables the hazard (including both ac and dc power sources) when the case, cover, or shield is removed or opened. [Source: AFSC DH 1-3, 1980; MIL-STD-1472F, 1999; MIL-STD-1800A, 1990; UCRL-15673, 1985]

Discussion. Human protection from hazardous conditions with unexpected energization or release of stored energy is treated in OSHA 29 CFR 1910.301 -308, 331 -335, and 399. The OSHA 29 CFR 1910.333 requires the simultaneous use of both tagout and lockout in the workplace; OSHA 29 CFR 1910.333 states that interlocks shall not be the sole means of de-energizing circuits of equipment and are not substitutes for lockout and tagout procedures and practice. [Source: AFSC DH 1-3, 1980; 29 CFR 1910.301 -308, 331 -335, and 399; MIL-STD-1472F, 1999; MIL-STD-1800A, 1990; UCRL-15673, 1985]

- **4.5.6.2 Interlock override switch.** If a task requires that a user work on hazardous equipment that is equipped with a disabling interlock, the equipment shall have an interlock override switch that permits manual bypassing or overriding of the interlock when the cover is open. This override switch shall automatically reset to the non-by-pass position, which is the safe operating position when the case or cover is replaced. OSHA 29 CFR 1910.333 requires that only qualified personnel be allowed to disable an interlock. [Source: AFSC DH 1-3, 1980; 29 CFR 1910.333; UCRL-15673, 1985]
- **4.5.6.3 Labeling covers with interlocks.** If a case, cover, or shield has an interlock, a label stating the presence of both the hazard and the interlock shall be placed on the equipment or the case or cover so that it is visible both when the case or cover is in place and when it is open or removed. [Source: MIL-STD-1472F, 1999]

Discussion. It is important that the label contain sufficient information, particularly if there is more than one hazard present. For example, if there is the possibility of an electrical hazard from either ac or dc current, such as when a system has battery backup, the label must inform of both hazards.

4.5.7 Labeling and marking

- **4.5.7.1 Method of opening.** If the method for opening a case or cover is not obvious, a label with opening instructions shall be attached to the outside of the cover itself or to the equipment adjacent to the cover. [Source: AFSC DH 1-3, 1980; MIL-STD-1472F, 1999; UCRL-15673, 1985]
- **4.5.7.2 Hazard labels.** If a hazardous condition exists inside a case or behind a cover, a label fully describing the hazard shall be attached to the case or cover itself or adjacent to the case or cover. Opening or removing the case or cover shall neither remove nor visually obstruct the label. [Source: MIL-STD-1472F, 1999]
- **4.5.7.3 Instructional labels.** If instructions are provided regarding maintenance tasks, components, test points or service points inside a case or opening, they shall be oriented horizontally with respect to the user and attached to the case or cover itself or adjacent to the equipment so that the instructions remain visible when the case or cover is opened. [Source: MIL-STD-1472F, 1999]

4.6 Fasteners

This section contains general rules for fasteners and specific rules for nuts and bolts, screws, the heads of bolts and screws, latches and catches, and other fastening devices. Additional rules are provided for quick fastening and releasing devices, captive fasteners, and the labeling and marking of fasteners.

Definition. Fasteners are devices that join, attach, and mount parts, components, cases, covers, and units of equipment. They include quick fastening and releasing devices, screws, bolts, latches, catches, rivets, retainer rings, and retainer chains. [Source: MIL-HDBK-759B, 1992; UCRL-15673, 1985]

Fasteners are available in a wide variety of types and sizes, and new types appear frequently. Designers are advised to review the varieties available before selecting fasteners for a particular application. Factors influencing the choice of a fastener for a particular application include (a) the stress and environmental factors the fastener must withstand, (b) the tools and clearance required to fasten and release the fastener, (c) the frequency with which the fastener will be fastened and released, (d) the speed with which the fastener must be fastened and released, (e) the types and varieties of other fasteners used in that and related applications, and (f) the clothing, especially gloves or mittens, the maintainer may be expected to wear. [Source: MIL-HDBK-759B, 1992; UCRL-15673, 1985]

4.6.1 General

- **4.6.1.1 Fastener security.** Fasteners shall hold securely in their operating environment, for example, withstanding the effects of vibration, wind gusts, and pressure. [Source: MIL-STD-1472F, 1999]
- **4.6.1.2 Number and ease of opening.** The fasteners for a given application shall be the fewest in number and the simplest to operate that meet the closure, structural, and ease of maintenance requirements for the application. [Source: MIL-STD-1472F, 1999]
- **4.6.1.3 Common fasteners.** To the extent possible, fasteners shall be interchangeable throughout a given application. [Source: MIL-HDBK-759B, 1992; UCRL-15673, 1985]
- **4.6.1.4 Self-alignment.** Fasteners shall be selected or designed so that they are easily aligned with their retaining catches, nuts, blocks, or inserts. This alignment shall occur without binding and without damage to fastener threads or receptacles. [Source: UCRL-15673, 1985]
- **4.6.1.5 Operable by hand or common hand tools.** Fasteners shall be operable by hand if possible; otherwise, by common hand tools. [Source: AFSC DH 1-3, 1980; MIL-STD-1472F, 1999; MIL-STD-1800A, 1990]

- **4.6.1.6 Open-closed indication.** Fasteners should give a clear indication that they are open (unfastened) or closed (fastened). [Source: MIL-STD-1472F, 1999]
- **4.6.1.7 Hole size.** The holes through which fasteners pass shall be large enough to permit inserting or "starting" the fasteners even when parts are not perfectly aligned. [Source: AFSC DH 1-3, 1980; MIL-HDBK-759B, 1992; MIL-STD-1800A, 1990]
- **4.6.1.8 Fastener variety.** The variety of fasteners used in a particular application (that is, the number of different types and sizes) shall be the minimum that meets the requirements for closure, structure, and ease of maintenance. These requirements include such aspects as stress, bonding, pressure, temperature, and shielding. [Source: MIL-HDBK-759B, 1992; MIL-STD-1472F, 1999; UCRL-15673, 1985]

Discussion. Minimizing the variety of fasteners simplifies the stocking of spare parts and reduces the danger that maintainers will damage fasteners or equipment by using the wrong tool or the wrong fastener. [Source: MIL-HDBK-759B, 1992; MIL-STD-1472F, 1999; UCRL-15673, 1985]

- **4.6.1.9 When different fasteners are required.** If removal or insertion of a wrong fastener could result in damage to equipment or a change in calibration settings, distinguishably different fasteners shall be used. [Source: MIL-STD-1472F, 1999]
- **4.6.1.10 Different fasteners must be distinguishable.** If more than one type of fastener is required for a unit of equipment:
 - a. The different types shall be easily distinguishable from each other, for example, screws with different threads might also be different in physical size. [Source: AFSC DH 1-3, 1980; MIL-HDBK-759B, 1992]
 - b. The fastener-receptacle interface shall permit the maintainer to distinguish the intended location of each fastener easily. [Source: MIL-STD-1472F, 1999]

- **4.6.1.11 Location of fasteners.** Fasteners shall be located so that they
 - a. are easily accessible to the maintainer without requiring the removal of other parts or units,
 - b. can be operated with little or no interference from other structures,
 - c. do not interfere with each other or with other components,
 - d. are not hazardous to maintainers or potentially damaging to wires or hoses, and
 - e. have adequate clearance to permit easy hand or tool operation. [Source: AFSC DH 1-3, 1980; MIL-HDBK-759B, 1992; UCRL-15673, 1985]
- **4.6.1.12 Strength of hand-operated fasteners.** Fasteners that are normally operated by hand shall be strong enough to withstand being operated with a tool. [Source: MIL-HDBK-759B, 1992]
- **4.6.1.13 Painted or coated fasteners.** If fasteners are painted or coated, the paint or coating shall not adversely affect their removal or installation. [Source: NASA-STD-3000A, 1989]
- **4.6.1.14 Precise torque requirements.** Equipment should be designed so that precise torque on fasteners is not required. If it is required, fasteners that incorporate torque indications should be used. [Source: AFSC DH 1-3, 1980]
 - Examples.** Some examples of fasteners that incorporate torque indications are (a) nuts that break away, (b) crushable washers that give a visual indication that correct torque has been reached, and (c) tools that crimp the nut and achieve the correct torque. [Source: AFSC DH 1-3, 1980]
- **4.6.1.15 Torqued fasteners.** If a precise torque is required, the fastener shall be located so that the torquing tool can be applied directly, without the use of irregular extensions. [Source: MIL-STD-1472F, 1999]
- **4.6.1.16 Quick-action fasteners.** Fasteners for cases and covers should be of the quick-action type, requiring only part of a turn or a snap action to fasten and unfasten. [Source: AFSC DH 1-3, 1980; MIL-HDBK-759B, 1992]
- **4.6.1.17 Covers as structural members.** When covers serve as stress-bearing structural members, their fasteners shall be large and strong enough to withstand the stress. [Source: UCRL-15673, 1985]

4.6.2 Number

- **4.6.2.1 Minimum that meets requirements.** The number of fasteners used in a particular application shall be the minimum number that meets the closure, structural, and ease of maintenance requirements. A few large fasteners are preferable to many small fasteners as long as they meet the requirements. [Source: AFSC DH 1-3, 1980; MIL-STD-1472F, 1999; MIL-STD-1800A, 1990; UCRL-15673, 1985]
- **4.6.2.2 Mounting.** No more than four fasteners should be used to mount a unit of equipment. [Source: UCRL-15673, 1985]
- **4.6.2.3 Minimize by using hinges, catches, latches, and quick fastening and releasing devices.** Hinges, catches, latches, and quick fastening and releasing devices should be used to reduce the number of fasteners whenever they meet the other relevant requirements. [Source: MIL-STD-1472F, 1999; UCRL-15673, 1985]
- **4.6.2.4 Minimize by using tongue-and-slot design.** Tongue-and-slot design should be used whenever possible in covers and cases to minimize the number of fasteners. [Source: AFSC DH 1-3, 1980; MIL-STD-1472F, 1999]

4.6.3 Types

This section lists rules for different types of fasteners. For ease of maintenance, the order of preference by type is: (a) quick fastening and releasing devices, (b) latches and catches, (c) captive fasteners, (d) screws, and (e) nuts and bolts. [Source: MIL-HDBK-759B, 1992]

4.6.3.1 Nuts and bolts

Nuts and bolts are relatively time consuming to install and remove. The maintainer usually has to have access to both ends of the bolt, to use both hands, and to make fairly precise movements in starting the nut. Often the maintainer has to use two tools, one for the bolt and one for the nut. The inclusion of washers increases the number of parts to handle and possibly lose.

- **4.6.3.1.1 Bolt length.** Bolts shall be no longer than necessary for their given application. If a nut is used, at least two threads of the bolt shall extend beyond the nut when the nut is tightened. [Source: MIL-HDBK-759B, 1992; UCRL-15673, 1985]
- **4.6.3.1.2 Bolt threads.** The bolt threads should be no finer than strength requirements dictate. [Source: MIL-HDBK-759B, 1992; UCRL-15673, 1985]
- **4.6.3.1.3 Turns to tighten.** The number of turns to tighten a bolt should be less than 10. [Source: UCRL-15673, 1985]
- **4.6.3.1.4 Hexagonal nuts.** Hexagonal nuts shall be used in high-torque applications. [Source: UCRL-15673, 1985]

- **4.6.3.1.5 Wing and knurled nuts.** Wing nuts or knurled nuts should be used in low-torque applications. [Source: MIL-HDBK-759B, 1992; UCRL-15673, 1985]
- **4.6.3.1.6 Left-hand threads.** Left-hand threaded nuts and bolts shall be used only when conditions require them, for example to prevent loosening due to rotation. When used, they shall be coded by marking, shape, or color so that they are easily distinguishable from right-hand threaded nuts and bolts. [Source: UCRL-15673, 1985; MIL-HDBK-759B, 1992]
- **4.6.3.1.7 Lock washers.** Lock washers or other restraining measures shall be used to prevent nuts and bolts from loosening under vibration. [Source: MIL-HDBK-759B, 1992]
- **4.6.3.1.8 Removal and replacement with one hand or tool.** Nuts and bolts that are removed and replaced frequently or that are relatively inaccessible should be mounted so that they can be removed and replaced with one hand or one tool. A recess should be provided to hold either the bolt or the nut. [Source: MIL-HDBK-759B, 1992]
- **4.6.3.1.9 Bolt mounting.** Bolts should be mounted with their heads up so that they remain in position if the nut falls off. [Source: UCRL-15673, 1985]

4.6.3.2 Screws

Screws are relatively time consuming to insert and remove, and their threads and slots are susceptible to damage. However, screwdrivers usually require less operating space than wrenches, and they usually require the use of only one hand. In addition, screws are usually used alone, as opposed to bolts, which are usually used in combination with washers and nuts. [Source: MIL-HDBK-759B, 1992; UCRL-15673, 1985]

- **4.6.3.2.1 Number of turns.** The number of turns to tighten or loosen a screw should be less than ten. [Source: UCRL-15673, 1985]
 - **4.6.3.2.2 Slot depth.** Screw heads should have deep slots that will resist damage. [Source: MIL-HDBK-759B, 1992; UCRL-15673, 1985]
 - **4.6.3.2.3 "Straight-in" screwdriver orientation.** Screws shall be used only when screwdrivers can be used in a "straight-in" orientation; the use of offset screwdrivers shall not be required. [Source: MIL-HDBK-759B, 1992; UCRL-15673, 1985]
 - **4.6.3.2.4 Blind operation.** If a screw must be operated in a position in which the maintainer cannot see its head, a guide shall be provided to help position the screwdriver. [Source: MIL-HDBK-759B, 1992; UCRL-15673, 1985]
- Example.** The screw might be located at the bottom of a cylindrical hole so that the hole guides the screwdriver to the screw head. [Source: MIL-HDBK-759B, 1992; UCRL-15673, 1985]
- **4.6.3.2.5 Screws for pressurized enclosures.** Fine-thread screws should be used for pressurized units. [Source: UCRL-15673, 1985]

- **4.6.3.2.6 Countersunk screws.** Screws should be countersunk when a smooth surface is required. [Source: UCRL-15673, 1985]
- **4.6.3.2.7 Screws for thin panels.** Flat-head screws should not be used on panels less than 2.4 mm (3/32 in) thick. [Source: UCRL-15673, 1985]
- **4.6.3.2.8 Self-tapping screws.** If a unit of equipment requires more than one size of self-tapping screw, the different sizes shall be kept to a minimum, and they shall all have the same type of head. [Source: UCRL-15673, 1985]

4.6.3.3 Screw and bolt heads

Combination-head bolts and screws are preferable to other bolts and screws because they allow operation with both wrenches and screwdrivers. Slotted hexagonal heads are preferable to slotted knurled heads. Combination-head bolts and screws reduce the likelihood of damaged slots and stuck fasteners. [Source: MIL-HDBK-759B, 1992; UCRL-15673, 1985]

- **4.6.3.3.1 Same heads for screws and bolts.** To the extent possible, all bolts and screws on a given unit of equipment shall have the same size and type of head so that maintainers can operate all of them with a single tool. [Source: MIL-STD-1472F, 1999]
- **4.6.3.3.2 Combination-head bolts and screws.** Combination-head bolts and screws should be used, preferably those having slotted, hexagonal heads. Exhibit 4.6.3.3.2 shows examples of combination-head bolts and screws; the combinations illustrated are slotted-hexagonal and slotted-knurled. [Source: MIL-STD-1472F, 1999]

Exhibit 4.6.3.3.2 Examples of combination-head bolts and screws

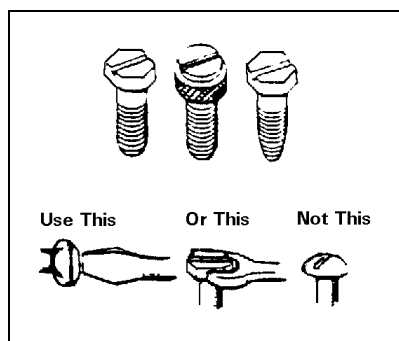

- **4.6.3.3.3 Straight-slot and cross-recess type internal fasteners.** Non-combination straight-slot or cross-recess type internal fasteners shall not be used except to fasten wood. [Source: MIL-STD-1472F, 1999]

- **4.6.3.3.4 Internal-wrenching fasteners -- where to use.** Internal-wrenching fasteners shall not be used except where a flat, smooth surface is required and where the fasteners are protected from the accumulation of foreign material such as dirt, ice, or snow. Exhibit 4.6.3.3.4 shows an example of an internal-wrenching bolt and an internal-wrenching nut. [Source: MIL-STD-1472F, 1999; UCRL-15673, 1985]

Exhibit 4.6.3.3.4 Example of an internal-wrenching bolt and nut

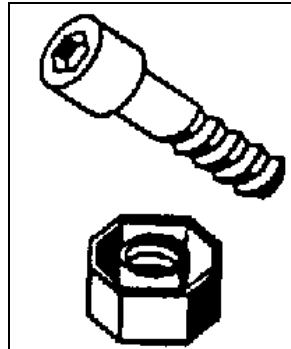

- **4.6.3.3.5 High-torque fasteners.** If a torque of more than 14 N·m (10 ft·lb) is required, fasteners shall have external hexagonal or double-hexagonal heads. If external-wrenching heads cannot meet functional or personnel safety requirements, or in situations in which the fastener is protected from accumulation of foreign material, internal-wrenching fasteners may be used. [Source: MIL-STD-1472F, 1999]
- **4.6.3.3.6 Low-torque fasteners.** If a torque of less than 14 N·m (10 ft·lb) is required, fastener heads should be one of the following types: (a) combination-head, (b) hexagonal, external-grip head, (c) hexagonal internal-grip heads, or (d) Torq-set. [Source: MIL-STD-1472F, 1999]

4.6.3.4 Latches and catches

Latches and catches can be operated quickly and easily. They do not require the use of tools, and they have good holding power, but they cannot be used where smooth surfaces are required. [Source: UCRL-15673, 1985]

- **4.6.3.4.1 Positive catch.** Latches and catches shall have a positive catch. [Source: UCRL-15673, 1985]
- **4.6.3.4.2 Visual indication.** Latches and catches shall give a clear visual indication that the latch or catch is engaged. [Source: UCRL-15673, 1985]
- **4.6.3.4.3 Spring-loading of catches.** Catches should be spring-loaded so that they lock on contact rather than requiring some other action by the maintainer. [Source: MIL-HDBK-759B, 1992; UCRL-15673, 1985]

- **4.6.3.4.4 Nonhazardous.** The spring action or snap-down force in a catch or latch shall not be so strong that it could injure the maintainer. [Source: MIL-HDBK-759B, 1992]
- **4.6.3.4.5 Associated handles.** If a latch or catch is associated with a handle, the release mechanism for the latch or catch shall be located on or near the handle so that release and opening can be accomplished with one hand. [Source: MIL-HDBK-759B, 1992]
- **4.6.3.4.6 Preventing inadvertent operation.** Latches and catches shall be located and positioned so that it is not likely that they will be operated inadvertently under normal operating conditions. [Source: UCRL-15673, 1985]

4.6.3.5 Other fastening devices

This section gives rules for a variety of additional fastening devices, including cotter pins and keys, retainer rings, safety wire, rivets, retainer chains, and washers.

- **4.6.3.5.1 Integral fasteners not allowed.** Fasteners shall not be an integral part of the equipment's housing; studs are an example of disallowed integral fasteners. [Source: MIL-HDBK-759B, 1992; UCRL-15673, 1985]
- **4.6.3.5.2 Cotter pins and keys.** Criteria for cotter pins and keys are:
 - a. Pins and keys should fit snugly, but not so tightly that they cannot be slid in and out by hand.
 - b. The heads of cotter keys should be large enough so that they do not slip through the hole and so that they are easy to remove. [Source: UCRL-15673, 1985]
- **4.6.3.5.3 Retainer rings.** Criteria for retainer rings are:
 - a. Retainer rings shall be easy to remove and replace when worn.
 - b. When possible, retainer rings shall lock into position with a positive snap.
 - c. Twist-to-lock retainer rings shall have spring tension to prevent their loosening. [Source: UCRL-15673, 1985]
- **4.6.3.5.4 Pin-and-hook fasteners.** If a cover must have the ability to survive nuclear, biological and chemical hazards, it should be attached with pins and hooks rather than hinges. [Source: MIL-STD-1472F, 1999]

- **4.6.3.5.5 Safety wire.** Criteria for safety wire are:
 - a. Safety wire shall be used only when self-locking fasteners or fasteners with cotter pins are not adequate to withstand the expected vibration or stress.
 - b. When safety wire is used, it shall be easy to remove and replace.
 - c. If a visible means of detecting that a fastener has become loosened or has changed position is required, safety wire shall be used. [Source: UCRL-15673, 1985]
- **4.6.3.5.6 Rivets.** Rivets are permanent fasteners that are difficult and time consuming to remove and replace; they are not ordinarily used on parts that might require removal. Criteria for rivets are:
 - a. Rivets shall not be used to attach hinges, latches, catches, or other quick fastening and releasing devices.
 - b. Rivets shall be of softer material than the pieces they fasten.
 - c. The holes for shear rivets shall be drilled to close tolerances. Maintenance instructions shall specify these tolerances and the sizes of plug gauges and reamers to be used. [Source: MIL-HDBK-759B, 1992; UCRL-15673, 1985]
- **4.6.3.5.7 Retainer chains.** Retainer chains or locking bars are used to (a) keep hatches or doors from opening too far or from springing their hinges, (b) convert doors or covers into shelves for the maintainer, (c) prevent small covers or caps from being misplaced, (d) secure small, special tools at the location where they will be used, (e) secure objects that might otherwise fall and get lost, and (f) secure objects that might otherwise fall and injure the maintainer or damage the equipment. Criteria for retainer chains are:
 - a. Only link, sash, or woven-mesh type chains should be used. Bead-link chain should not be used; it is more breakable than other types.
 - b. Retainer chains should be attached with screws or bolts so that they can be disconnected easily if necessary.
 - c. Each end of a retainer chain should have an eyelet.
 - d. Retainer chains for filler caps should be attached externally, not internally.
 - e. Chains should not be used where they might interfere with moving parts.
 - f. If chain covers are required, they should be flexible and durable. [Source: UCRL-15673, 1985]

- **4.6.3.5.8 Washers.** Criteria for washers are:
 - a. Washers should fit tightly against the underside of the fastener head.
 - b. Washers should fit the shaft snugly, but should be easy to remove.
 - c. Split-ring washers should be used with static loads in excess of 55 g (2 oz).
 - d. Lock washers should be used with lock nuts for maximum locking action. [Source: UCRL-15673, 1985]

4.6.3.6 Quick fastening and releasing devices

Quick fastening and releasing devices are quick (by definition) and easy to use. They require no tools; they can be operated with only one hand; and they are good for securing plug-in components, small components, and covers. However, they have relatively low holding power, and they cannot be used where a smooth surface is required. [Source: MIL-HDBK-759B, 1992; UCRL-15673, 1985]

- **4.6.3.6.1 Frequent access.** Quick fastening and releasing devices shall be used for components that must be dismantled or removed frequently. [Source: MIL-HDBK-759B, 1992; MIL-STD-1472F, 1999; UCRL-15673, 1985]
- **4.6.3.6.2 Tools not required.** Quick fastening and releasing devices shall fasten and release easily without the use of tools. [Source: MIL-HDBK-759B, 1992; UCRL-15673, 1985]
- **4.6.3.6.3 Single motion.** Quick fastening and releasing devices shall operate with a single motion of the hand, for example, requiring no more than one complete revolution. [Source: MIL-HDBK-759B, 1992; UCRL-15673, 1985]
- **4.6.3.6.4 Visual indication of state.** Quick fastening and releasing devices shall give a clear visual indication that they are fastened or released. [Source: MIL-HDBK-759B, 1992; UCRL-15673, 1985]
- **4.6.3.6.5 Minimum turns.** Wherever bolts or screws are used, they shall be selected so that fastening them requires only the minimum number of turns necessary to meet the closure and structural requirements of the application. [Source: AFSC DH 1-3, 1980; MIL-STD-1472F, 1999]

Discussion. Bolts and screws requiring more than the minimum number of turns may be excepted from this rule if they are used to reduce the variety of fasteners in a unit of equipment. [Source: AFSC DH 1-3, 1980; MIL-STD-1472F, 1999]

4.6.3.7 Captive versus removable

Captive fasteners can be time consuming and difficult to operate. They usually require the use of a tool, but the tool can usually be operated with one hand. The fasteners stay in place, thus saving handling time and avoiding the possible loss of parts. [Source: MIL-HDBK-759B, 1992; UCRL-15673, 1985]

- **4.6.3.7.1 When to use.** Captive fasteners shall be used whenever dropping a fastener or a related part, such as a washer or bolt, might cause damage or excessive loss of time. [Source: UCRL-15673, 1985; MIL-HDBK-759B, 1992; MIL-STD-1472F, 1999]
- **4.6.3.7.2 Operation and replacement.** Captive fasteners shall be operable by hand or with common hand tools, and they shall be easily replaceable if damaged. [Source: UCRL-15673, 1985; MIL-HDBK-759B, 1992]
- **4.6.3.7.3 "Quarter-turn" fasteners.** If "quarter-turn" type fasteners are used, they shall be self-locking and spring-loaded. [Source: UCRL-15673, 1985; MIL-HDBK-759B, 1992]
- **4.6.3.7.4 Access covers.** Access covers that are removed frequently should have captive fasteners. [Source: MIL-STD-1472F, 1999]
- **4.6.3.7.5 Small removable pins, caps, and covers.** Small removable pins, caps, and covers should be attached, probably with a retainer chain, so that they are not lost or dropped into the equipment. [Source: MIL-HDBK-759B, 1992]
- **4.6.3.7.6 Mounting bolts.** Mounting bolts should be semi-permanently captive, perhaps by means of "snap-on" collars. [Source: AFSC DH 1-3, 1980]

4.6.4 Labeling, marking, and coding

- **4.6.4.1 Mounting bolts.** Bolts that mount units of equipment should be color coded or perhaps embossed with the letter "M" to distinguish them from other visible fasteners. [Source: AFSC DH 1-3, 1980]
- **4.6.4.2 Fasteners requiring torquing.** Fasteners that require a precise torque should have labels on or near the fasteners stating the required torque value and the torquing sequence. [Source: MIL-STD-1472F, 1999]
- **4.6.4.3 Durability of marking.** If fasteners are marked or coded, the marks or codes shall withstand exposure to any chemicals, fuels, weather, or other adverse conditions in their ambient environment. [Source: UCRL-15673, 1985]
- **4.6.4.4 Consistent coding.** If a coding system for fasteners is used, it shall be consistent throughout a unit of equipment and for similar or related units of equipment. [Source: UCRL-15673, 1985]

4.7 Connectors

This section contains rules for various types of connectors (plug-in, threaded, and quick-action), for the location and accessibility of connectors, and for alignment aids. It also contains rules specific to electrical connectors and to fluid and gas connectors, including rules for their labeling and marking.

Definition. A **connector** is a piece of hardware that joins or attaches lines or cables to other lines or cables or to units of equipment. The term is used rather loosely to refer to either of the two parts that mate with each other and to the plug that mates with a receptacle.

4.7.1 General

- **4.7.1.1 Fluid and gas line connectors.** Connectors utilized for fluid and gas lines should comply with Paragraph 4.8.2 Fluid and gas lines.
- **4.7.1.2 Connector gaskets and seals.** Gaskets and seals used in connectors should comply with Paragraph 4.8.2.4 Gaskets and seals.
- **4.7.1.3 Fast, easy operation.** Connectors shall be selected or designed to permit fast, easy maintenance operations, including such tasks as testing, servicing, removing, and replacing units of equipment and components. [Source: MIL-HDBK-759B, 1992]
- **4.7.1.4 Safety.** Connectors shall be selected or designed to ensure the safety of maintainers and equipment from pressures, contents, or voltages during the release of connectors. [Source: MIL-HDBK-759B, 1992]
- **4.7.1.5 Hand or common tool operation.** Connectors shall be selected or designed to permit operation by hand or by common hand tools. [Source: MIL-HDBK-759B, 1992; UCRL-15673, 1985]
- **4.7.1.6 Compatibility.** Connectors shall be selected or designed to be compatible with their associated lines and cables, fasteners, mounting, environmental extremes, and maintenance routines. [Source: MIL-HDBK-759B, 1992]
- **4.7.1.7 Protection of connectors.** If a connector is susceptible to damage, it shall be protected by one or more of the following measures: (a) recessing the receptacle, (b) recessing delicate parts such as pins and keys within the connector, and (c) providing a protective cap, insert, cover, case, or shield. [Source: MIL-HDBK-759B, 1992]
- **4.7.1.8 Captive covers.** If a connector has a protective cover, the cover shall be of the captive type. [Source: MIL-STD-1472F, 1999; MIL-STD-1800A, 1990]

4.7.2 Types

4.7.2.1 Distinctive

- **4.7.2.1.1 Distinctive types.** Connectors for lines serving different functions, for example, fuel lines and water lines, or electrical power lines and radio-frequency signal lines, shall be distinctively different and physically incompatible. [Source: UCRL-15673, 1985]
- **4.7.2.1.2 Preventing mismatching.** Connectors serving the same or similar functions shall be selected or designed to minimize the likelihood of mismatching. [Source: MIL-HDBK-759B, 1992]

Discussion. Preferably this will be accomplished by making the connectors physically incompatible, for example, by using connectors of different sizes or by using alignment pins or keys. If that is not feasible, coding by color may be acceptable.

4.7.2.2 Plug-in

Plug-in connectors are the easiest and least time consuming to use, but they have low holding power. They are particularly convenient where frequent connection and disconnection is required. [Source: MIL-HDBK-759B, 1992; UCRL-15673, 1985]

- **4.7.2.2.1 When to use.** If a line or cable is likely to be connected and disconnected frequently, and if the line or cable is not likely to be pulled accidentally, plug-in connectors should be used. [Source: MIL-HDBK-759B, 1992]
- **4.7.2.2.2 Preventing damage.** Plug-in connectors and their receptacles shall be selected or designed so that the plug cannot be inserted into a receptacle that it does not match. An attempt to insert a plug into a non-matching receptacle shall damage neither the plug nor the receptacle. [Source: MIL-STD-1800A, 1990]

4.7.2.3 Threaded

Threaded connectors provide very secure connections, particularly when locked in place with set screws, retainers, or safety wires. They are more time consuming to connect and disconnect than plug-in connectors.

- **4.7.2.3.1 Ease of operation.** Threaded connectors shall be selected or designed so that they meet the holding requirements for the connection with a minimum number of turns. [Source: MIL-HDBK-759B, 1992]

4.7.2.4 Quick-action

Quick-action connectors are, as their name implies, quick and easy to use. They include connectors that operate in one of the following ways: (a) by a snap action, (b) by rotating the connector up to one complete turn, (c) by triggering a latch or spring device, and (d) by removal of an external pin. Exhibit 4.7.2.4 illustrates a common type of quick-action connector, one that operates with a quarter-turn rotation. [Source: MIL-HDBK-759B, 1992; UCRL-15673, 1985]

Exhibit 4.7.2.4 Example of a quick-action connector
[Source: UCRL-15673, 1985]

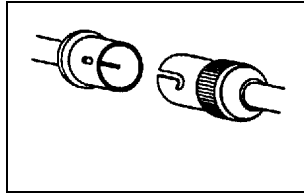

- **4.7.2.4.1 When to use.** Quick-action connectors shall be used when units of equipment or components must be connected or disconnected frequently or when connection and disconnection must be completed quickly, provided that they meet all other requirements for the connection, such as holding or sealing. [Source: AFSC DH 1-3, 1980; MIL-HDBK-759B, 1992; MIL-STD-1472F, 1999; MIL-STD-1800A, 1990; UCRL-15673, 1985]
- **4.7.2.4.2 Self-locking.** Quick-action connectors shall have self-locking catches that prevent loosening and ensure a secure connection. [Source: UCRL-15673, 1985]

4.7.3 Location and accessibility

- **4.7.3.1 Visual and physical access.** Connectors shall be located so that maintainers can see, reach, connect, and disconnect them easily and safely. [Source: MIL-HDBK-759B, 1992; NASA-STD-3000A, 1989]
- **4.7.3.2 Unobstructed access.** Connectors shall be located so that they can be seen and reached without the disassembly or removal of other equipment or components. [Source: MIL-HDBK-759B, 1992]
- **4.7.3.3 Relative accessibility.** The connectors that are connected and disconnected most frequently shall be the most accessible. [Source: MIL-HDBK-759B, 1992]
- **4.7.3.4 Full access.** The rear of plug connectors shall be accessible for testing and servicing. [Source: MIL-STD-1472F, 1999; MIL-STD-1800A, 1990; NASA-STD-3000A, 1989]
- **4.7.3.5 Protected from dislodging and damage.** Connectors shall be located so that they are not dislodged or damaged by the movement of people or objects in their vicinity. [Source: MIL-HDBK-759B, 1992]

- **4.7.3.6 Minimum spacing.** The space between a connector and any other connector or obstruction shall be sufficient to permit the connector to be grasped as firmly as necessary for connecting and disconnecting it. This spacing shall be at least:
 - a. 25 mm (1 in) if the connector is operated with bare fingers,
 - b. 32 mm (1.25 in) if the connector is operated with gloved fingers,
 - c. 64 mm (2.5 in) if the connector must be "gripped firmly," and
 - d. 75mm (3 in) if the connector is operated with mittened hands. [Source: AFSC DH 1-3, 1980; MIL-HDBK-759B, 1992; MIL-STD-1472F, 1999]
- **4.7.3.7 Measuring clearance.** Clearance shall be measured from the outermost portion of the connector, that is, from the backshell, strain relief clamp, dust cover, or electromagnetic interference shield or radio frequency interference shield, if they exist, and it shall permit a rotation of at least 270°. [Source: AFSC DH 1-3, 1980; MIL-HDBK-759B, 1992; MIL-STD-1472F, 1999]
- **4.7.3.8 Space for wrench.** If the connector requires high torque, there shall be enough space around it to permit use of a wrench. [Source: MIL-STD-1472F, 1999]

4.7.4 Alignment aids

- **4.7.4.1 Preventing misalignment.** Wherever a particular orientation of a connector is required, the connector and its receptacle shall be provided with an aligning device, such as a pin or key way, that prevents the connector from being inserted in any but the correct orientation. [Source: MIL-STD-1472F, 1999; MIL-STD-1800A, 1990]
 - Discussion.** Even when an alignment device is provided, care must be taken to ensure that the connector is not symmetric, which would permit connection 180° from the correct orientation.
- **4.7.4.2 Alignment before contact.** Alignment devices shall ensure that correct alignment is achieved before electrical contact is made. [Source: MIL-STD-1472F, 1999; MIL-STD-1800A, 1990; UCRL-15673, 1985; MIL-STD-1472F, 1999; MIL-STD-1800A, 1990]
- **4.7.4.3 Aligning the alignment devices.** If a unit of equipment has more than one connector having the same sort of alignment device, all of those connectors shall be oriented so that the alignment device is in the same relative position. For example, all alignment keys might be at the top. [Source: MIL-STD-1472F, 1999]

- **4.7.4.4 Alignment coding.** If a connector has an alignment device, the connector shall be durably marked or coded to show the position of the alignment device. Methods for marking or coding include painted stripes and arrows. [Source: MIL-STD-1472F, 1999; MIL-STD-1800A, 1990; MIL-HDBK-759B, 1992; AFSC DH 1-3, 1980]
- **4.7.4.5 Alignment of drawer connectors.** If a module or unit of equipment is mounted in a drawer with a connector at the back that mates with a connector in the rack, guide pins or other alignment devices shall be provided to ensure proper mating. [Source: MIL-STD-1472F, 1999]

4.7.5 Electrical connections

4.7.5.1 Plugs and receptacles

- **4.7.5.1.1 Fast, easy connection.** Unless precluded by other requirements, electrical connectors should be of the plug-in or quick-action types. [Source: UCRL-15673, 1985]
- **4.7.5.1.2 Prevention of insertion errors.** Electrical plugs shall be selected or designed so that it is physically impossible to insert a plug in the wrong receptacle or to insert it into a receptacle the wrong way. Some ways in which this can be accomplished are:
 - a. Use plugs with polarized prongs or prongs of different sizes,
 - b. Use plugs having different numbers of pins or different configurations of pins, and
 - c. Use plugs of different sizes. [Source: MIL-HDBK-759B, 1992; UCRL-15673, 1985]
- **4.7.5.1.3 Alignment.** Alignment of electrical connections should comply with Paragraph 4.7.4 Alignment aids.
- **4.7.5.1.4 Few plugs, many contacts.** Where applicable, electrical connections shall be accomplished by using few connectors with many contacts rather than many connectors with few contacts. [Source: AFSC DH 1-3, 1980; MIL-HDBK-759B, 1992; UCRL-15673, 1985]
- **4.7.5.1.5 "Hot" leads.** Wiring shall be routed through plugs and receptacles so that "hot" leads are not exposed in either the plug or the receptacle when they are disconnected. [Source: MIL-HDBK-759B, 1992]
- **4.7.5.1.6 "Cold" plugs.** Wiring shall be routed so that receptacles are "hot," and plugs are "cold" when they are disconnected. [Source: AFSC DH 1-3, 1980; MIL-HDBK-759B, 1992; UCRL-15673, 1985]
- **4.7.5.1.7 Electrical charges.** Disconnected plugs and leads shall not expose maintainers to stored electrical charges. [Source: UCRL-15673, 1985]

- **4.7.5.1.8 Self-locking or latching.** Electrical connectors should be self-locking or should have safety catches; they should not require safety wire. [Source: AFSC DH 1-3, 1980; MIL-HDBK-759B, 1992; UCRL-15673, 1985]
- **4.7.5.1.9 Insertion force.** Electrical connectors should require low insertion forces to minimize the possibility of damaging the connector or injuring the maintainer. [Source: MIL-HDBK-759B, 1992]
- **4.7.5.1.10 Durability.** Plugs and pins shall be selected or designed to withstand rough use. [Source: UCRL-15673, 1985]
- **4.7.5.1.11 Non-shorting contacts.** Connectors shall be selected or designed so that electrical contacts cannot be shorted by external objects. [Source: AFSC DH 1-3, 1980; UCRL-15673, 1985]
- **4.7.5.1.12 Pin identification.** Each pin on each plug shall be clearly identified or coded, using labels or color or shape coding. [Source: AFSC DH 1-3, 1980; UCRL-15673, 1985]
- **4.7.5.1.13 Test points.** If test points are required to measure inputs or outputs that cannot be easily checked otherwise, they should be provided: (a) on the plug itself, or (b) on an adapter that can be inserted between the plug and the receptacle. [Source: AFSC DH 1-3, 1980; UCRL-15673, 1985]
- **4.7.5.1.14 Disassembly by hand or using common hand tools.** The disassembly of connectors to change pin connections should not require the use of special tools; it should be possible by hand or with the use of common hand tools. [Source: AFSC DH 1-3, 1980; UCRL-15673, 1985]
- **4.7.5.1.15 Drawer module connectors.** Units of equipment that are mounted in drawers and that do not require that connections be maintained when the drawer is extended, shall be provided with plugs mounted on the back of the drawer. These plugs shall have alignment guides that allow the unit to be slid back into place and mate with receptacles in the cabinet to accomplish whatever electrical interconnections among the drawer, other equipment in the cabinet, and external connections are required. [Source: MIL-STD-1800A, 1990]

4.7.5.2 Wire connections

This section contains rules governing the arrangement and attachment of individual wires. Lugs and crimp-on devices are preferable to wire-wrap, pig tailing, and soldering for connecting or splicing individual wires. Soldering provides the most secure connection, but it is also the most time-consuming.

- **4.7.5.2.1 Spacing of leads.** It shall be easy for maintainers to perform any necessary operations on leads, in particular connecting and disconnecting them. This may be accomplished by adequate spacing of the terminals to which they are attached, or by ensuring that the leads are long enough that the maintainer can separate them. [Source: MIL-HDBK-759B, 1992]

- **4.7.5.2.2 Extra wire length.** If wires terminate in lugs or crimp-on devices, the wires shall be long enough to permit at least six replacements of the devices. Exhibit 4.7.5.2.2 illustrates an example of a crimp-on splice. [Source: UCRL-15673, 1985]

Exhibit 4.7.5.2.2 Example of a crimp-on splice.

[Source: UCRL-15673, 1985]

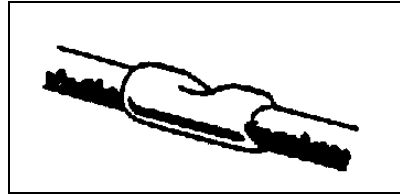

- **4.7.5.2.3 Clamping insulation.** Lugs and crimp-on devices shall clamp the insulation as well as the conductor. [Source: UCRL-15673, 1985]
- **4.7.5.2.4 Compatibility of lugs with terminals.** Lugs shall be compatible with terminal post requirements. [Source: UCRL-15673, 1985]
- **4.7.5.2.5 U-lugs.** U-lugs should be used rather than O-lugs (or eye lugs). Exhibit 4.7.5.2.5 illustrates a U-lug and an O-lug. [Source: UCRL-15673, 1985; AFSC DH 1-3, 1980]

Exhibit 4.7.5.2.5 Examples of a U-lug and an O-lug [Source: UCRL-15673, 1985]

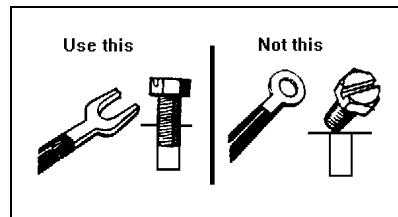

- **4.7.5.2.6 Soldered connections.** Soldered connections shall be compatible with terminal post requirements. [Source: UCRL-15673, 1985]
- **4.7.5.2.7 Spacing of terminals.** Terminals to which wires are to be soldered shall be far enough apart that work on one terminal does not damage neighboring terminals or nearby parts. [Source: UCRL-15673, 1985; AFSC DH 1-3, 1980]
- **4.7.5.2.8 Length of terminals.** Terminals or other connections to which wires are soldered shall be long enough that soldering does not damage anything nearby. [Source: UCRL-15673, 1985; AFSC DH 1-3, 1980]
- **4.7.5.2.9 Soldered wires.** The end of a wire soldered to a terminal shall extend beyond the solder so that the wire will be easy to remove. [Source: UCRL-15673, 1985]

- **4.7.5.2.10 Wire wrapping or pig tailing.** Wire wrapping and pig tailing shall not be used unless authorized by the acquisition program office. [Source: UCRL-15673, 1985]

4.7.6 Labeling, marking, and coding

Coding and identifying connectors and associated parts can expedite maintenance and troubleshooting procedures by keying the connectors to references in job instructions and by identifying replaceable parts for ordering. Labeling, marking and coding can also provide appropriate warnings and cautions.

- **4.7.6.1 Matching connectors or plugs and receptacles.** Each connector or plug and its corresponding connector or receptacle shall be labeled or coded so that the two parts are easily matched. [Source: MIL-HDBK-759B, 1992]
- **4.7.6.2 Non-interchangeable connectors.** Non-interchangeable connectors shall be labeled or coded so that they are clearly distinguishable. Coding methods include shape, size, and color. [Source: MIL-HDBK-759B, 1992]
- **4.7.6.3 Matching wires to terminals or pins.** Each wire in a connector or receptacle shall be clearly identified with its terminal post or pin. [Source: MIL-HDBK-759B, 1992]
- **4.7.6.4 Identification of terminals on terminal strips or blocks.** Terminals on terminal strips or blocks shall be identified on the terminal strip or block itself or on the chassis, adjacent to the terminals (same as paragraphs 4.8.1.8.3 and 4.9.5.8). [Source: AFSC DH 1-3, 1980; UCRL-15673, 1985]
- **4.7.6.5 Location of labels and codes -- connectors.** Labels and codes on connectors shall be located, in order of preference, (a) directly on the connector, (b) on plates permanently attached to the connector, or (c) on tabs or tapes attached to the connector. [Source: MIL-HDBK-759B, 1992]
- **4.7.6.6 Location of labels and codes -- receptacles.** Labels and codes for receptacles shall be located, in order of preference, (a) directly on the receptacle, (b) on the surface or panel immediately adjacent to the receptacle or, if it is recessed, adjacent to its access opening. [Source: MIL-HDBK-759B, 1992]
- **4.7.6.7 Consistency of labels and codes.** Labels and codes on connectors shall be consistent with labels and codes on associated items, such as pins, terminals, and receptacles. [Source: MIL-HDBK-759B, 1992]
- **4.7.6.8 Warnings and cautions.** If any hazard to maintainers or equipment exists in the connection or disconnection of a connector, the connector shall be labeled or coded with an appropriate warning or caution. [Source: MIL-HDBK-759B, 1992]

- **4.7.6.9 Marking electrical connections.** Marking adjacent to plugs, jacks and other electrical connectors shall identify the connected circuits to preclude cross connections. [Source: MIL-HDBK-454]

4.8 Lines and cables

General rules for lines and cables are given in this section. The routing and mounting of electrical cables (including extension and mock-up cables) and fluid and gas lines are covered, as well as their labeling and marking.

Definitions. A **cable** is a number of lines bound together within a single, permanent sheath. A **line** is any single length of pipe, wire, or tubing.

Lines and cables most often end in connectors, and some rules regarding connectors are also given in this section. See Section 4.7 for detailed information pertaining to connectors. [Source: UCRL-15673, 1985]

4.8.1 Electrical

4.8.1.1 General

- **4.8.1.1.1 Selection.** Lines and cables shall be selected, designed, bound, mounted, and routed to:
 - a. preclude wear out, breakage, or damage,
 - b. facilitate logical and efficient divisions of maintenance responsibilities, and
 - c. allow maintainers to quickly and easily: (a) troubleshoot, test, check, and isolate malfunctions, (b) remove, repair, and replace other units of equipment and components, and (c) connect and disconnect lines and cables. [Source: MIL-HDBK-759B, 1992; UCRL-15673, 1985]
- **4.8.1.1.2 Insulation.** Clear plastic insulation should be used where possible to allow rapid detection of internal breaks. [Source: UCRL-15673, 1985]
- **4.8.1.1.3 Minimization.** Lines and cables should be designed to minimize the number of:
 - a. types and varieties of lines and cables,
 - b. different lengths of otherwise identical lines or cables, and
 - c. related connectors, fittings, and fixtures. [Source: UCRL-15673, 1985]

- **4.8.1.1.4 Quick-action connections.** When maintenance requires that cables be connected or disconnected easily or frequently, cables shall terminate in quick-action connectors. [Source: UCRL-15673, 1985]
- **4.8.1.1.5 Cable "fan out".** The wires in cables shall "fan out" as seen in Exhibit 4.8.1.1.5 so that the individual wires can be attached to junction boxes, terminal blocks, or other mounts. Each attachment point shall be easily identifiable and easy to reach with test probes. [Source: MIL-HDBK-759B, 1992]

Exhibit 4.8.1.1.5 Fanning out cables [Source: UCRL-15673, 1985]

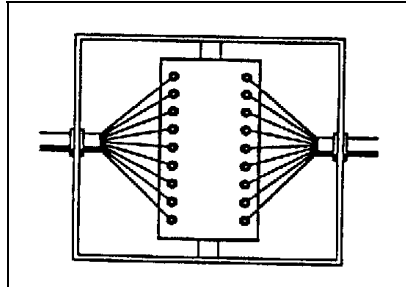

- **4.8.1.1.6 Preformed cables.** Preformed cables should be used wherever possible to minimize wiring errors and allow for the use of more flexible and efficient assembly methods. Spare lines should be included to allow for growth and to speed wiring time as agreed upon by the acquisition agency. [Source: UCRL-15673, 1985]
- **4.8.1.1.7 Harnesses.** When harnesses are used, they shall
 - a. be designed, fabricated, and installed as units,
 - b. be held securely with lacing twine or other means acceptable to the user, and
 - c. keep the individual conductors essentially parallel, so they do not intertwine, though twisted pairs may be used when required. [Source: UCRL-15673, 1985; AFSC DH 1-3, 1980]
- **4.8.1.1.8 Protection.** Shields or other protection shall be provided for easily damaged conductors such as waveguides, high-frequency cables, and insulated high-voltage cables. [Source: MIL-HDBK-759B, 1992]
- **4.8.1.1.9 Exposed cables.** Exposed cables shall be protected from mechanical damage. For example, armored cables might be used where damage is likely. [Source: MIL-HDBK-759B, 1992]
- **4.8.1.1.10 Special purpose cables.** Cables intended for use in the presence of nuclear, biological, or chemical hazards shall be sealed. [Source: MIL-STD-1800A, 1990]

- **4.8.1.1.11 Insect protection.** If damage from termites is likely, line and cable insulation shall be protected by coating it with compounds of creosote, antimony, or other acceptable mixtures. [Source: UCRL-15673, 1985]
- **4.8.1.1.12 Fluid protection.** All electrical lines and cables shall be protected from oil, grease, fuel, hydraulic fluid, water or cleaning solvents. These may damage insulation and may result in injury to personnel. [Source: MIL-HDBK-759B, 1992]
- **4.8.1.1.13 Storage space.** If long electrical cables are required for auxiliary power or test equipment, storage space shall be provided. [Source: MIL-HDBK-759B, 1992]

Example. Often, a storage compartment is present, but no easy means is provided for coiling the wire into a shape and size that will permit storage. A simple means of accomplishing this is a cable winder, a device around which the cable can be wrapped (see Exhibit 4.8.1.1.13).

Exhibit 4.8.1.1.13 Cable winder

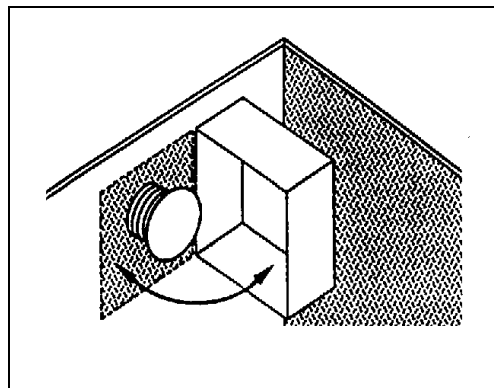

- **4.8.1.1.14 Use of grommets.** When cables must pass over sharp edges, insulation shall be protected from fraying or other damage by grommets or equivalent means. [Source: MIL-STD-1472F, 1999; MIL-HDBK-759B, 1992]

4.8.1.2 Length of cables and leads

- **4.8.1.2.1 Length of cables.** If a circuit might be affected by differences in the length of a cable, the length of cables should be the same for each installation of a given type of electronic equipment. [Source: MIL-HDBK-759B, 1992; AFSC DH 1-3, 1980]

Discussion. Even if a unit can be adjusted to compensate for differences in the length of the cable, using different lengths of cable means that an adjustment made on the bench might be out of tolerance when the unit is installed. [Source: MIL-HDBK-759B, 1992; AFSC DH 1-3, 1980]

- **4.8.1.2.2 Extra cable.** Cables shall be long enough so that a unit of equipment can be moved to a convenient place for maintenance activities; extension cables shall be provided if necessary. [Source: AFSC DH 1-3, 1980; MIL-STD-1472F, 1999; MIL-STD-1800A, 1990]
- **4.8.1.2.3 Accessibility.** Cables shall be long enough so that units of equipment mounted in drawers and on slide-out racks can be worked on without breaking electrical connections. [Source: AFSC DH 1-3, 1980; MIL-STD-1800A, 1990]
- **4.8.1.2.4 Cable length and connectors.** Cables shall be long enough so that connectors can be easily connected and disconnected. [Source: AFSC DH 1-3, 1980; NASA-STD-3000A, 1989]
- **4.8.1.2.5 Length of leads.** Lead lengths shall be as short as possible but long enough to allow all of the following that apply (see Paragraph 4.7.5.2.1):
 - a. easy connection and disconnection, with enough slack to back the wire away from the point of attachment to facilitate removal of the unit,
 - b. sufficient slack for at least two (preferably six) replacements of terminal fittings, electrical considerations permitting,
 - c. movements of parts to which they may be attached (doors, covers, and the like) without undue stress or bending,
 - d. connection, disconnection, or movement without requiring a bending radius of less than six times the diameter of the lead, and
 - e. movement of the units that are difficult to handle in their mounted position to a more convenient position for connection or disconnection. [Source: UCRL-15673, 1985; MIL-HDBK-759B, 1992]

- **4.8.1.2.6 Slack.** Leads or cables to moving parts, doors, and covers shall have adequate slack and protection so that they
 - a. permit movement, such as pulling out a drawer for maintenance, without breaking the electrical connection,
 - b. fold out of the way when the part is moved,
 - c. are not pinched or otherwise damaged when the part is returned to its original position (see Exhibit 4.8.1.2.6 for the use of springs and cable mechanisms to prevent pinching),
 - d. do not chafe or break under the repeated flexing required. [Source: MIL-HDBK-759B, 1992; UCRL-15673, 1985]

Exhibit 4.8.1.2.6 Recoiling slack cable

[Source: MIL-HDBK-759B, 1992]

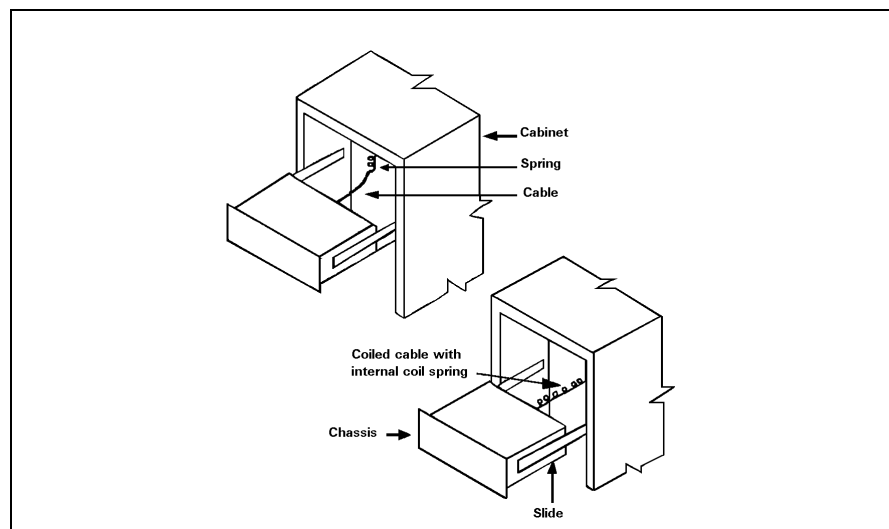

4.8.1.3 Routing and mounting

- **4.8.1.3.1 Routing considerations.** Lines and cables shall be routed so they will not be
 - a. pinched or stressed by loose objects, doors, lids, covers, sliding drawers, or roll-out racks,
 - b. walked on or rolled over by heavy traffic,
 - c. used for hand- or foot-holds (a protective guard should be placed over the cables where the possibility of such use exists), or
 - d. bent or sharply twisted. [Source: AFSC DH 1-3, 1980]

- **4.8.1.3.2 Combining lines.** The layout and routing of lines shall be determined during design and made as simple and functionally logical as possible by combining lines into cables (preferable) or combining lines into harnesses if cables are not used. [Source: UCRL-15673, 1985]
- **4.8.1.3.3 Segregate conductors.** Conductors shall be segregated into cables or harnesses according to their functions and relationships to replaceable equipment. [Source: UCRL-15673, 1985]
- **4.8.1.3.4 Routing over pipes.** Electrical wires and cables shall be mounted above, rather than under, pipes or fluid containers. [Source: MIL-HDBK-759B, 1992]
- **4.8.1.3.5 Lightly insulated wires.** Lines and cables that are lightly insulated shall be at least 19 mm (0.75 in) from a potential ground. [Source: UCRL-15673, 1985]
- **4.8.1.3.6 Protection.** Raceways, stuffing tubes, conduit, junction boxes, and insulation shall be provided as necessary to obtain the required degree of protection, security of mounting, and ease of maintenance. [Source: UCRL-15673, 1985]
- **4.8.1.3.7 Visual and physical access.** Lines, cables, and wire harnesses shall be routed so that they are readily accessible for inspection and repair, especially at points of connection, splicing, and testing. [Source: NASA-STD-3000A, 1989; MIL-STD-1800A, 1990; MIL-STD-1472F, 1999; MIL-HDBK-759B, 1992; UCRL-15673, 1985]
- **4.8.1.3.8 Unobstructed access.** Lines and cables shall be accessible without requiring disassembly or removal of other equipment or components. [Source: MIL-HDBK-759B, 1992]
- **4.8.1.3.9 Replacement.** Lines and cables shall be accessible throughout their route for removal and replacement if they are damaged. [Source: MIL-HDBK-759B, 1992]
- **4.8.1.3.10 Areas to avoid.** High voltage lines and cables shall be routed away from sensitive equipment, high temperature sources, work areas, controls, and the like. [Source: UCRL-15673, 1985; MIL-HDBK-759B, 1992]
- **4.8.1.3.11 Ease of maintenance.** Line and cable routing shall facilitate maintenance by ensuring that each unit of equipment can be moved to a convenient place for maintenance activities; extension cables shall be provided if necessary. [Source: MIL-HDBK-759B, 1992]
- **4.8.1.3.12 Non-obstruction.** Line and cable routing shall not obstruct visual or physical access to equipment for operation or maintenance. [Source: MIL-STD-1472F, 1999]

- **4.8.1.3.13 Remote switches.** Lines and cables shall not be routed through remote switches that may be turned on and off inadvertently while maintenance is being performed. [Source: UCRL-15673, 1985]
- **4.8.1.3.14 Cables within racks.** Cables shall not be terminated or mounted on the front of cabinets, control panels, display panels, or on the face of equipment racks. Test cables are an exception to this criterion (see Paragraph 4.8.1.6.4). [Source: NASA-STD-3000A, 1989; UCRL-15673, 1985]
- **4.8.1.3.15 Shortest route.** Lines and cables shall be routed over the shortest runs allowable by lead, mounting, and other requirements. [Source: UCRL-15673, 1985]

4.8.1.4 Leads

- **4.8.1.4.1 No weight-bearing.** Leads shall be mounted so that they do not bear the weight of cables, harnesses, or other components. [Source: UCRL-15673, 1985]
- **4.8.1.4.2 Support.** Leads shall be mounted so that they are supported at splices and points of connection. [Source: UCRL-15673, 1985]
- **4.8.1.4.3 Orientation.** Where possible, leads shall be mounted so that they are oriented in a way that prevents erroneous connection or "crossing". [Source: UCRL-15673, 1985]
- **4.8.1.4.4 No flexing.** Leads shall be mounted so that they do not allow flexing at weak areas, for example, at splices, solder points, points where the conductor is bare or crimped, or points where strands are tinned together. [Source: UCRL-15673, 1985]
- **4.8.1.4.5 Signal checks.** Signal flow checks shall be made possible by the appropriate arrangement, location, and mounting of leads. [Source: UCRL-15673, 1985]

4.8.1.5 Clamps and mounting plates

- **4.8.1.5.1 Snug fit.** Clamps and mounting plates shall fit snugly without deforming or crimping the line or cable. [Source: UCRL-15673, 1985]
- **4.8.1.5.2 Spacing.** Clamps and mounting plates shall be operable by hand or with common hand tools. [Source: MIL-HDBK-759B, 1992; UCRL-15673, 1985]

- **4.8.1.5.3 Special clamps.** Quick-release clamps (hinged or spring) shall be used if cables are removed frequently. Hinged clamps are preferable for non-overhead mounting, because they support the weight of the line during maintenance, freeing the maintainer's hands for other tasks. Exhibit 4.8.1.5.3 shows these two types of clamps. [Source: MIL-HDBK-759B, 1992]

Discussion. For overhead mounting, a spring clamp with a hinged, locking latch over the clamp's open side is preferable because it would help prevent accidents. [Source: MIL-HDBK-759B, 1992]

Exhibit 4.8.1.5.3 Quick-release clamps, hinged and spring

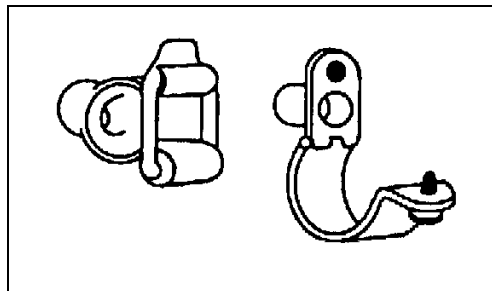

- **4.8.1.5.4 Placement.** Clamps and mounting plates shall be located at both ends of bends where the bending radius is 75 mm (3 in) or less. [Source: UCRL-15673, 1985]
- **4.8.1.5.5 Unsupported cable.** Lengths of cable or wire longer than 300 mm (12 in) shall be attached to the equipment chassis by means of clamps, unless contained in wiring ducts or cable retractors. [Source: MIL-STD-1800A, 1990; MIL-HDBK-759B, 1992]
- **4.8.1.5.6 Visibility of clamps.** All clamps shall be visible when equipment is installed. [Source: MIL-STD-1800A, 1990]
- **4.8.1.5.7 Mechanically-mounted clamps.** If a wire or cable is not routed through a wiring duct or conduit, it shall be attached with mechanically-mounted (not adhesive) cable clamps. [Source: MIL-STD-1472F, 1999]

Discussion. Mechanically-mounted clamps can ensure the correct routing of electrical cables within and between units of equipment. They can also (a) ensure that cables do not hinder or obstruct equipment maintenance, (b) prevent chafing due to contact with an adjacent surface, and (c) facilitate the mating of cables with their associated equipment. [Source: MIL-STD-1472F, 1999]

- **4.8.1.5.8 Non-conductive.** Clamps and mounting plates that secure a conductor shall be nonconductive or properly insulated. [Source: UCRL-15673, 1985]

4.8.1.6 Test and extension cables

Test and extension cables need to be planned, designed, and provided to increase the efficiency and ease of maintenance.

- **4.8.1.6.1 Easy access.** Test and extension cables shall allow equipment and components to be moved to a convenient location for the performance of maintenance activities. [Source: UCRL-15673, 1985]
- **4.8.1.6.2 Multiple related functions.** Test and extension cables should serve as many related functions as possible, but should avoid the possibility of misuse or misconnection. [Source: UCRL-15673, 1985]
- **4.8.1.6.3 Support equipment.** Test and extension cables shall permit support equipment to be placed in a convenient location. [Source: UCRL-15673, 1985]
- **4.8.1.6.4 Noninterference.** If it is essential that test cables terminate on control and display panels, the panel test receptacles shall be located so that the test cables will not visually or physically interfere with operational controls and displays. [Source: NASA-STD-3000A, 1989; MIL-STD-1800A, 1990]
- **4.8.1.6.5 Storage provisions.** Adequate storage shall be provided for test and extension cables. For example, racks, hooks, or cable winders might be provided within the storage place. [Source: UCRL-15673, 1985]
- **4.8.1.6.6 Handling devices for cable.** Reels or reel carts shall be provided for handling large, heavy, or long lines of cable (see Exhibit 4.8.1.6.6). [Source: UCRL-15673, 1985]

Exhibit 4.8.1.6.6 An example of a line and cable reel cart.
[Source: UCRL-15673, 1985]



- **4.8.1.6.7 Automatic rewind.** If reels or reel carts are provided, they should rewind the cable automatically, when possible. [Source: UCRL-15673, 1985]

- **4.8.1.6.8 Mobile support.** If especially large lines or cables must be moved frequently, wheels or other mobile supports shall be provided. Exhibit 4.8.1.6.8 shows an example of a line and cable mobile support. [Source: UCRL-15673, 1985]

Exhibit 4.8.1.6.8 Line and cable mobile support

[Source: UCRL-15673, 1985]

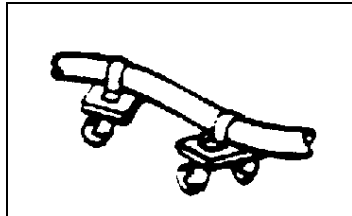

4.8.1.7 Bench mockup cables

- **4.8.1.7.1 Extension cables.** Bench mockups shall have extension cables for all units so that the units can be removed from the bench mockup for the performance of maintenance activities. [Source: AFSC DH 1-3, 1980]
- **4.8.1.7.2 Connectors on mockup cables.** Bench mockup cables shall have connectors that require only a strong push or pull to connect or disconnect them. Bench mockup cables are not subject to strong vibration or shock, but they are connected and disconnected frequently. [Source: AFSC DH 1-3, 1980]
- **4.8.1.7.3 Coverings.** Mockup cables shall have an extra-heavy covering (for example, vinyl tubing) to protect them from wear resulting from frequent connection and disconnection. [Source: AFSC DH 1-3, 1980]
- **4.8.1.7.4 Checking signal flow.** Bench mockup cables, including extension cables for units of equipment, shall have test points to check the signal flow through each wire. [Source: AFSC DH 1-3, 1980]

Examples. One method for accomplishing this is to provide test points at the connector; another is to provide test points on the junction boxes or terminal strips. [Source: AFSC DH 1-3, 1980]

4.8.1.8 Labeling, marking, and coding

- **4.8.1.8.1 Coding wire.** Insulated wire, cables, and electrical connectors shall be color- or number-coded in accordance with standards (for example, MIL-STD-195 and MIL-STD-681) acceptable to the acquisition agency. [Source: UCRL-15673, 1985; MIL-HDBK-759B, 1992]

Discussion. Number-coded wire, cables, and electrical connectors are preferred so that maintainers who have problems discriminating various colors may be able to identify these items. [Source: UCRL-15673, 1985; MIL-HDBK-759B, 1992]

- **4.8.1.8.2 Identification.** Cables shall be labeled to indicate the equipment with which they are associated and the connectors with which they mate. [Source: MIL-STD-1472F, 1999; MIL-STD-1800A, 1990]
- **4.8.1.8.3 Identification of terminals on terminal strips or blocks.** Terminals on terminal strips or blocks shall be identified on the terminal strip or block itself or on the chassis, adjacent to the terminals (same as Paragraphs 4.7.6.4 and 4.9.5.8). [Source: AFSC DH 1-3, 1980; UCRL-15673, 1985]

- **4.8.1.8.4 Methods of color-coding.** Conductors shall be color-coded using, in order of preference, (a) solid-color insulation, (b) solid-color insulation with a colored-stripe tracer, or (c) color braid insulation with a woven tracer. [Source: MIL-HDBK-759B, 1992]

Explanation. Exhibit 4.8.1.8.4 shows 12 different pattern variations based on different insulation and tracer colors. For more than 12 wires, see MIL-STD-686C. If a wire's color-coding is susceptible to becoming obscured, wires may be coded with numbered metal tags. [Source: MIL-HDBK-759B, 1992]

Exhibit 4.8.1.8.4 Electrical cable coding

<u>Number of Conductor</u>	<u>Basic Color</u>	<u>Tracer</u>
1	Black	None
2	White	None
3	Red	None
4	Green	None
5	Orange	None
6	Blue	None
7	White	Black
8	Red	Black
9	Green	Black
10	Orange	Black
11	Blue	Black
12	Black	White

- **4.8.1.8.5 Cables within a sheath.** Cables containing individually insulated conductors with a common sheath shall be coded. The coding shall be repeated every 300 mm (12 in) along their entire length. [Source: MIL-STD-1472F, 1999; MIL-STD-1800A, 1990]
- **4.8.1.8.6 Coding for orientation.** Coding by such means as color or labels shall identify the correct item and its proper orientation or replacement. [Source: MIL-STD-1472F, 1999]

4.8.2 Fluid and gas lines

4.8.2.1 General

- **4.8.2.1.1 Connectors.** Fluid and gas line connectors should comply with Section 4.7 Connectors.
- **4.8.2.1.2 Use of flexible tubing.** Flexible tubing should be used instead of rigid lines because it allows more flexibility in handling, can be backed-off easily, and is easier to thread through equipment when replacement is required. [Source: MIL-HDBK-759B, 1992; UCRL-15673, 1985]
- **4.8.2.1.3 Use of flexible hose.** Flexible hose should be used rather than pipes or tubing where minimum space is available for removing, handling, or replacing lines. [Source: UCRL-15673, 1985]
- **4.8.2.1.4 Quick-action connectors.** Quick-action connectors shall be used on lines that require frequent disconnection. [Source: MIL-HDBK-759B, 1992; UCRL-15673, 1985]
- **4.8.2.1.5 Preventing leakage.** When quick-action connectors are used, self-sealing features should be provided to prevent leakage of fluid when the line is disconnected. [Source: MIL-HDBK-759B, 1992; UCRL-15673, 1985]
- **4.8.2.1.6 Leakage tests.** Fluid and gas line connectors shall be located and installed so that leakage tests can be performed easily and without danger to the maintainer or the equipment. [Source: MIL-HDBK-759B, 1992; UCRL-15673, 1985]
- **4.8.2.1.7 Control of leakage and spillage.** Fluid and gas line connectors shall be selected or designed so that leakage and accidental spillage during connection and disconnection are prevented or controlled so that they do not injure maintainers or damage equipment. [Source: MIL-HDBK-759B, 1992; NASA-STD-3000A, 1989]
- **4.8.2.1.8 Standardized fittings.** To avoid the possibility of mismatching connectors during service or maintenance, fittings shall be standardized so that lines that differ in the substances they carry cannot be interchanged. [Source: MIL-HDBK-759B, 1992; UCRL-15673, 1985]
- **4.8.2.1.9 Avoiding spraying fluids.** Lines shall be kept from spraying or draining fluid on personnel or equipment during disconnection by locating connections away from work areas and sensitive components, shielding sensitive components where required, and providing drains and bleed fittings so lines can be drained or depressurized before they are disconnected. [Source: MIL-HDBK-759B, 1992; UCRL-15673, 1985]

- **4.8.2.1.10 High-pressure lines.** Systems that contain liquids or high pressure gases (pressures exceeding 125 psi) shall be provided with isolation or disconnect valves to permit isolation for servicing and to aid in leak detection. [Source: NASA-STD-3000A, 1989]
- **4.8.2.1.11 Cutoff valves.** Cutoff valves shall be provided at appropriate locations in the system to permit isolation or drainage of the system for maintenance and during emergencies. [Source: MIL-HDBK-759B, 1992; UCRL-15673, 1985]
- **4.8.2.1.12 Draining and filling.** Fluid and gas line connectors shall be located and installed so that draining, filling, and other maintenance involving the connectors or lines can be accomplished without jacking up the equipment. [Source: UCRL-15673, 1985; MIL-HDBK-759B, 1992]
- **4.8.2.1.13 Avoiding drainage problems.** Drainage problems shall be avoided by
 - a. designing lines so they can be emptied completely if necessary,
 - b. making bends horizontal, rather than vertical, to avoid fluid traps,
 - c. avoiding low points or dips in lines that make them difficult to drain, and
 - d. providing special drains where low points do occur. [Source: MIL-HDBK-759B, 1992]
- **4.8.2.1.14 Exposure to noise and vibration.** Fluid and gas line connectors shall be located and installed so that maintenance activities involving them do not require that the maintainer be exposed to extreme noise, vibration, or other danger. [Source: MIL-HDBK-759B, 1992]

4.8.2.2 Routing and mounting

- **4.8.2.2.1 Accessibility.** Fluid and gas lines mounted in cable trays shall be located for ready access. [Source: NASA-STD-3000A, 1989]
- **4.8.2.2.2 Connectors for rigid lines.** Connectors for rigid fluid and gas lines shall be located and installed so that it is not necessary to back the lines off or remove other equipment or components to connect or disconnect the connectors. [Source: UCRL-15673, 1985]

Discussion. Protruding gaskets or seals might be susceptible to damage, and that damage might spread internally, destroying the seal. Tapered nylon or Teflon washers of appropriate size can be employed to prevent extrusion. [Source: UCRL-15673, 1985]

- **4.8.2.2.3 Areas to avoid.** High-pressure lines and cables shall be routed away from sensitive equipment, high temperature sources, work areas, controls, and the like. [Source: MIL-HDBK-759B, 1992; UCRL-15673, 1985]
- **4.8.2.2.4 Fuel lines.** Fuel lines shall be routed below electrical cables and hot pipes. [Source: MIL-HDBK-759B, 1992]
- **4.8.2.2.5 Heat resistant liners.** If fluid and gas lines are likely to become extremely hot, clamps and mounting plates shall be lined with heat resistant material so the maintainer will not be burned. [Source: UCRL-15673, 1985; MIL-HDBK-759B, 1992]
- **4.8.2.2.6 Avoiding line kinking.** Fluid and gas lines should be installed and mounted with sufficient clearance from surrounding equipment and structures to allow the maintainer to disconnect and remove the lines without bending or kinking them. [Source: UCRL-15673, 1985]

4.8.2.3 Clamps and supports

- **4.8.2.3.1 External service supports.** Unmounted lines attached to equipment (for example, lines from external service or test equipment or lines attached for other purposes) shall have supports capable of withstanding
 - a. the initial surges of pressure through the line,
 - b. the weight of external extensions, and
 - c. the wear and tear of handling and repeated connection and disconnection. [Source: UCRL-15673, 1985; MIL-HDBK-759B, 1992]
- **4.8.2.3.2 Spring clamps.** Spring clamps shall be used to mount tubing and fluid pipes that may require frequent removal and replacement. [Source: MIL-HDBK-759B, 1992]

Discussion. For overhead mounting, a spring clamp shall be used with a hinged-locking latch over the clamp's open side to prevent accidents (see Paragraph 4.8.1.5.3). [Source: MIL-HDBK-759B, 1992]

4.8.2.4 Gaskets and seals

- **4.8.2.4.1 Replaceable, renewable gaskets and seals.** Gaskets and seals used in connectors for fluid and gas lines shall be selected and installed to be replaceable or to have renewable wearing surfaces; it shall not be necessary to discard the connector when the seal is damaged or worn. [Source: UCRL-15673, 1985]
- **4.8.2.4.2 Repair and replacement of gaskets and seals.** Gaskets and seals used in connectors for fluid and gas lines shall be easily inserted and removed, without requiring the removal of other connector parts or the disassembly of other equipment. [Source: MIL-HDBK-759B, 1992; UCRL-15673, 1985]

- **4.8.2.4.3 Ability to identify gaskets and seals.** Part numbers for gaskets and seals used in connectors for fluid and gas lines shall be easily identifiable. This may be accomplished through labeling, coding, marking, or user documentation. [Source: UCRL-15673, 1985]
- **4.8.2.4.4 Life expectancy of gaskets and seals.** Job instructions shall state the life expectancy of gaskets and seals and recommend when they should be changed. [Source: UCRL-15673, 1985; MIL-HDBK-759B, 1992]
- **4.8.2.4.5 Prevent entrance of air.** If the entrance of air into a disconnected fluid or gas line would create a maintenance problem, as for example, in a hydraulic line, gaskets and seals used in connectors shall prevent the entrance of air when the line is disconnected. [Source: UCRL-15673, 1985]
- **4.8.2.4.6 Tightening to offset shrinkage.** If a gasket or seal used in a fluid or gas line connector is subject to shrinkage, the connector shall permit tightening to offset the shrinkage. [Source: UCRL-15673, 1985]
- **4.8.2.4.7 Visibility.** Gaskets and seals used in fluid and gas line connectors shall be visible after they are installed so that maintainers can see that the gasket or seal is present as illustrated in Exhibit 4.8.2.4.7. [Source: MIL-HDBK-759B, 1992]

Exhibit 4.8.2.4.7 Externally visible seals

[Source: MIL-HDBK-759B, 1992]

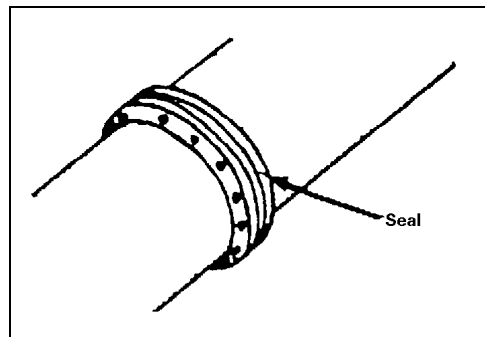

- **4.8.2.4.8 Non-protrusion.** Gaskets and seals used in fluid and gas connectors shall not protrude beyond the coupling. [Source: UCRL-15673, 1985]

Discussion. Protruding gaskets and seals might be susceptible to damage, and that damage might spread internally, destroying the seal. Tapered nylon or Teflon washers of appropriate size can be employed to prevent extrusion. [Source: UCRL-15673, 1985]

4.8.2.5 Labeling, marking, and coding

- **4.8.2.5.1 Fluid conductor coding.** Fluid conductors shall be either color coded (see Exhibit 4.8.2.5.1), or coded by metal tags. Metal tags shall be used where adverse conditions (such as grease or mud) could obscure colors; otherwise, color-coding shall be used. [Source: MIL-HDBK-759B, 1992; UCRL-15673, 1985]

Exhibit 4.8.2.5.1 Color-coding of fluid conductors

Contents	Valve handwheels and operating levers	Fed. Std 595 color number and chip
Steam	White	17886
Potable water	Dark blue	15044
Nitrogen	Light gray	16376
High pressure air	Dark gray	16081
Low pressure air	Tan	10324
Oxygen	Light green	14449
Salt water	Dark green	14062
Fuel oil	Yellow	13538
Lube oil	Yellow	13538
Fire protection	Red	11105
Foam discharge	Striped red/ green	11105 14062
Gasoline	Yellow	13538
Feedwater	Light blue	15200
Hydraulic	Orange	12246
Freon	Dark purple	17100
Hydrogen	Chartreuse	23814
Sewage	Gold	17043

- **4.8.2.5.2 Valve color-coding.** Valves shall be color-coded in accordance with the substances they control or the function they perform. Exhibit 4.8.2.5.2 lists recommended color codes for valves by substance. [Source: UCRL-15673, 1985]

Exhibit 4.8.2.5.2 Valve color-coding scheme

Contents	Color
Fuel	Red
Water injection	Red -gray-red
Lubrication	Yellow
Hydraulic	Blue & yellow
Pneumatic	Orange & blue
Instrument air	Orange & gray
Coolant	Blue
Breathing oxygen	Green
Air conditioning	Brown & gray
Fire protection	Brown
De-icing	Gray
Compressed gases	Orange
Electrical conduit	Brown & orange

- **4.8.2.5.3 Hydraulic and pneumatic line coding.** Hydraulic and pneumatic lines shall be coded based on arrangement, size, shape, and color as necessary. Exhibit 4.8.2.5.3 lists color-codes for lines by function. [Source: MIL-HDBK-759B, 1992; UCRL-15673, 1985]

Exhibit 4.8.2.5.3 Hydraulic and pneumatic line color-coding scheme

Function	Color	Definition of function
Intensified pressure	Black	Pressure in excess of supply pressure induced by booster or intensifier.
Supply pressure	Red	Pressure of the power-actuating fluid.
Charging pressure	Intermittent red	Pump-inlet pressure, higher than atmospheric pressure.
Reduced pressure	Intermittent red	Auxiliary pressure lower than supply pressure.
Metered flow	Yellow	Fluid at a controlled flow rate (other than pump delivery).
Exhaust	Blue	Return of the power-actuating fluid to reservoir.
Intake side	Green	Subatmospheric pressure, usually on the intake of the pump.
Drain	Green	Return of leakage of control-actuating fluid to reservoir.
Inactive	Blank	Fluid within the circuit but not serving a functional purpose during the phase being represented.

- **4.8.2.5.4 Label contents.** Codes and labels shall be provided on, or adjacent to, the line as necessary to indicate the direction of flow. [Source: MIL-HDBK-759B, 1992]
- **4.8.2.5.5 Valve position labeling.** Labels or other marking devices shall be provided to clearly designate the position of a valve control. Exhibit 4.8.2.5.5 illustrates labeling of a valve control. [Source: UCRL-15673, 1985]

Example. A rider, as illustrated in Exhibit 4.8.2.5.5, may be attached to the shaft to indicate the fully opened and fully closed positions. [Source: UCRL-15673, 1985]

Exhibit 4.8.2.5.5 Value position labeling
[Source: UCRL-15673, 1985]

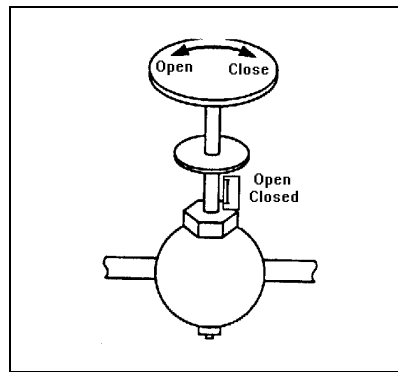

4.9 Packaging, layout, and mounting of internal components

Criteria and rules for the packaging, layout, mounting, labeling, and marking of internal modules, components, and parts are given in this section. All of these can affect the ease or difficulty of maintenance activities.

Definitions. A **module** is an assemblage of two or more interconnected parts or components that comprise a single physical and functional entity (for example, a printed circuit board). It is this singular functionality that defines a module. A **component** is a subdivision of a unit of equipment that can be treated as an object by the maintainer, but which can be further broken down into parts. A mounting board together with its mounted parts is an example of a component. A **part** is an object that cannot normally be broken down further without destroying its designated use. Fuses, resistors, and capacitors are examples of parts. **Packaging** is the grouping of functions, components, and parts into units or modules; **layout** is the physical arrangement of the parts and components that make up a module or a unit of equipment; **mounting** is the positioning and attachment of parts, components, and modules.

4.9.1 General

- **4.9.1.1 Accessibility.** Parts and modules on which maintenance is performed shall be positioned so that the maintainer has complete visual and physical access. [Source: MIL-HDBK-759B, 1992]
- **4.9.1.2 Minimize tool requirements.** Parts and modules shall be packaged, laid out, and mounted so that maintenance activities require a minimum number and variety of tools, preferably only common hand tools. [Source: MIL-HDBK-759B, 1992]
- **4.9.1.3 Minimize maintainer movement.** Parts and modules should be packaged, laid out, and mounted so that a minimum of movement is required of the maintainer in carrying out maintenance activities. [Source: UCRL-15673, 1985]
- **4.9.1.4 Organized by maintenance specialty.** Parts and modules should be packaged, laid out, and mounted so that maintenance activities by one maintenance specialist do not require removal or handling of equipment or components maintained by another specialist. [Source: UCRL-15673, 1985]

4.9.2 Packaging

Dividing a unit of equipment into a number of separate modules has several advantages: it can permit specialization by maintainers; it can speed up corrective maintenance; and it can make working on malfunctioning units easier.

Definition. Modularization is the separation of equipment into physically and functionally distinct units that can be easily removed and replaced.

4.9.2.1 Modularization

- **4.9.2.1.1 Modularization.** Units of equipment should be divided into as many modules as are electrically and mechanically practical and feasible for maintenance (see also Paragraph 4.1.2.7). [Source: AFSC DH 1-3, 1980; MIL-STD-1800A, 1990; UCRL-15673, 1985]
- **4.9.2.1.2 Single function.** A module shall contain only parts that contribute to a single function; it shall not provide multiple, divergent functions. [Source: UCRL-15673, 1985]
- **4.9.2.1.3 Physical and functional interchangeability.** If modules are physically interchangeable, they shall also be functionally interchangeable; if they are not functionally interchangeable, they shall not be physically interchangeable. [Source: MIL-HDBK-759B, 1992; MIL-STD-1472F, 1999; NASA-STD-3000A, 1989]
- **4.9.2.1.4 Ability to distinguish non-interchangeable modules.** Non-interchangeable modules shall be distinguishably different in appearance, and this difference shall be apparent when the module is in its installed position. [Source: NASA-STD-3000A, 1989]
- **4.9.2.1.5 Unreliable components.** If a module contains some parts that are significantly less reliable than the remaining parts, the unreliable parts should be accessible without removal of the module. [Source: UCRL-15673, 1985]
- **4.9.2.1.6 Maintenance in installed location.** Modules shall be designed so that required maintenance can be performed with the module in its installed position, without requiring disconnection, disassembly, or removal of other modules. [Source: MIL-HDBK-759B, 1992]
- **4.9.2.1.7 Testing.** Modules shall be designed to permit testing when they are removed from their installed position, and they shall require little or no calibration immediately after installation. [Source: UCRL-15673, 1985]

4.9.2.2 Modularization methods

The breaking up of a unit of equipment into modules is done in accordance with one or more of the following methods: (a) logical flow packaging, (b) circuit packaging, or (c) component packaging.

In logical flow packaging, circuits, parts, and components are packaged and arranged in correspondence with their functional relationships.

In circuit packaging, all parts of a single circuit or logically related group of parts, and only that circuit or group, are placed in a separate module.

In component packaging, similar parts or components are located together; for example, all the fuses or all the relays might be grouped together.

- **4.9.2.2.1 Modularization method.** The modularization of equipment should be done using one or more of the following methods, in this order of preference: (a) logical flow packaging, (b) circuit packaging, (c) component packaging. [Source: UCRL-15673, 1985]
- **4.9.2.2.2 Logical flow packaging.** If logical flow packaging is used:
 - a. Circuits and parts shall be packaged and located in an arrangement that parallels their functional relationships.
 - b. A module shall be designed so that only single input and output checks are necessary to isolate a fault in the module.
 - c. The unidirectional signal flow within a module shall be clearly indicated. [Source: UCRL-15673, 1985]
- **4.9.2.2.3 Circuit packaging.** If circuit packaging is used:
 - a. All parts of a given circuit or group of logically related parts shall be located in a single module.
 - b. A module shall contain only one circuit or group of related parts.
 - c. The circuit shall be packaged as a single terminal board or plug-in module when possible.
 - d. Circuits shall be grouped to minimize crisscrossing of signals among modules. [Source: UCRL-15673, 1985]

- **4.9.2.2.4 Component packaging.** If component packaging is used:
 - a. Similar components should be grouped in one location, for example, all fuses or all relays.
 - b. Inexpensive components should be placed on separate plug-in boards that can be discarded upon failure.
 - c. Similar parts that are likely to require replacement at approximately the same time should be grouped together.
 - d. Components requiring the same maintenance activity should be grouped together; for example test points or components requiring a particular cleaning method. [Source: UCRL-15673, 1985]

- **4.9.2.2.5 Printed circuit boards.** If printed circuit boards are used:
 - a. Printed circuit boards shall be designed and mounted for ease of removal and foolproof replacement.
 - b. Plug-in printed circuit boards shall be structurally rigid and easy to remove and replace, providing finger access and gripping aids if necessary.
 - c. Feedback shall be provided to the maintainer when plug-in printed circuit boards are securely connected.
 - d. Printed circuit boards shall be identified in accordance with MIL-STD-130, and references for parts mounted on the board shall be provided in accordance with MIL-HDBK-454, Requirement 67. [Source: MIL-STD-1472F, 1999]

4.9.3 Layout

Rules governing the layout of the parts that make up a module fall into three general categories: (a) accessibility of the parts, (b) logical or functional grouping of parts, and (c) protection of maintainers and equipment from hazards.

4.9.3.1 Accessibility

- **4.9.3.1.1 No interference from other parts.** Modules shall be laid out so that all parts can be removed and replaced without interference from and without removal of other parts. [Source: AFSC DH 1-3, 1980; MIL-HDBK-759B, 1992]

- **4.9.3.1.2 No stacking of parts.** The parts that make up a module shall be mounted in an orderly, flat, two-dimensional array; they shall not be stacked one on top of another. [Source: AFSC DH 1-3, 1980; MIL-STD-1472F, 1999]

- **4.9.3.1.3 Consistent orientation.** If a module has more than one part of the same type that must be inserted in a particular orientation (connectors, for example), all those parts should be oriented in the same direction. [Source: AFSC DH 1-3, 1980; MIL-HDBK-759B, 1992]
- **4.9.3.1.4 Spacing of parts.** The parts that make up a module shall be positioned so that any required tools (such as test probes or soldering irons) can be used without difficulty. [Source: AFSC DH 1-3, 1980; MIL-HDBK-759B, 1992]
- **4.9.3.1.5 Separation of parts and wiring on printed circuit boards.** On printed circuit boards, all parts shall be mounted on one side of the board, and all wiring (including printed circuits) shall be placed on the other side. [Source: AFSC DH 1-3, 1980; UCRL-15673, 1985]
- **4.9.3.1.6 Frequently inspected component parts.** Parts that require frequent visual inspection (fuses, for example) shall be located where they can be seen easily without the removal of panels, covers, or other modules. [Source: AFSC DH 1-3, 1980]
- **4.9.3.1.7 High failure-rate parts.** Parts that have a high failure rate, such as fuses, shall be located where they can be seen and replaced without the removal of other parts. [Source: AFSC DH 1-3, 1980; MIL-STD-1472F, 1999]
- **4.9.3.1.8 Indicator lights.** If a module contains indicator lights, it should be possible to change the lights from the front panel, that is, without opening or removing the module. [Source: UCRL-15673, 1985]
- **4.9.3.1.9 Shutoff switches.** If the module contains emergency shutoff switches, they shall be positioned within easy reach of the maintainer, and they shall be located or guarded to prevent inadvertent operation. [Source: MIL-STD-1800A, 1990]
- **4.9.3.1.10 Visual and physical accessibility.** Test points, adjustment points, and cable and line connectors shall be located where the maintainer can see them easily and perform any required operations on them without interference. [Source: UCRL-15673, 1985]

4.9.3.2 Grouping of parts

- **4.9.3.2.1 Grouping maintenance displays.** All maintenance displays relevant to a particular task shall be grouped together and located where they are easily visible to the maintainer. [Source: UCRL-15673, 1985]
- **4.9.3.2.2 Separating maintenance and operational displays.** If a module contains both maintenance and operational displays, the maintenance displays should be separated from the operational displays. [Source: UCRL-15673, 1985]

4.9.3.3 Hazard protection

- **4.9.3.3.1 Avoidance of damage to parts and wiring.** The parts and wiring of a module shall be located and arranged so that they are not damaged when the module or the unit of equipment of which they are part is opened and closed. [Source: AFSC DH 1-3, 1980]
- **4.9.3.3.2 Avoidance of damage from handling.** Parts that are susceptible to damage during maintenance activities shall be located or shielded so that they will not be damaged during these activities. [Source: AFSC DH 1-3, 1980; MIL-STD-1472F, 1999; UCRL-15673, 1985]
- **4.9.3.3.3 Avoidance of damage from the environment.** Parts shall be positioned so that they are not likely to be damaged by oil, other fluids, dirt, or static electricity. [Source: UCRL-15673, 1985]
- **4.9.3.3.4 Protecting maintainers from heat and electrical shock.** If a module contains parts that retain heat or electrical potential after power is turned off, those parts shall be located where maintainers will not touch them during maintenance activities, or they shall be shielded to protect the maintainers. In addition, heat-producing parts shall be shielded to protect maintainers from injury. [Source: AFSC DH 1-3, 1980; MIL-HDBK-759B, 1992; UCRL-15673, 1985]
- **4.9.3.3.5 Bleeder networks.** Parts that retain electrical potential after power is turned off shall be equipped with bleeder networks. [Source: MIL-HDBK-759B, 1992]
- **4.9.3.3.6 Separating internal controls from hazardous voltages.** Internal controls such as switches and adjustment controls shall not be located where maintainers might come into contact with hazardous voltages while operating the controls. [Source: AFSC DH 1-3, 1980; MIL-HDBK-759B, 1992; UCRL-15673, 1985]
- **4.9.3.3.7 High current switching devices.** High current switching devices shall be shielded to prevent maintainers from coming into contact with them. [Source: MIL-HDBK-759B, 1992; UCRL-15673, 1985]

4.9.4 Mounting

This section describes several methods for mounting modules and gives criteria and rules pertaining to these methods; it then lists more general criteria and rules. In mounting a particular module, it may be appropriate to use more than one of these methods simultaneously. [Source: UCRL-15673, 1985]

- **4.9.4.1 Foldout mounting.** Foldout mounting should be used whenever feasible. Exhibit 4.9.4.1 gives an example of foldout mounting. [Source: MIL-HDBK-759B, 1992; UCRL-15673, 1985]

Exhibit 4.9.4.1 Example of foldout mounting construction

[Source: AFSC DH 1-3, 1980; MIL-HDBK-759B, 1992, 5.6.18.11; UCRL-15673, 1985]

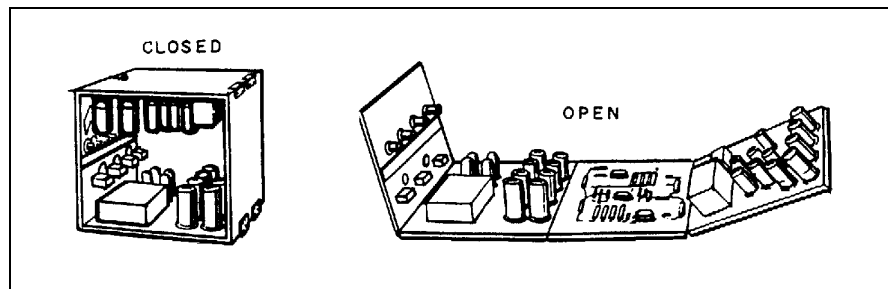

- **4.9.4.2 Prevention of damage with foldout mounting.** If foldout mounting is used, parts and wiring shall be positioned so that they are not damaged during opening and closing. [Source: MIL-HDBK-759B, 1992; UCRL-15673, 1985]
- **4.9.4.3 Support for hinged mounting.** If a module is mounted on hinges, some sort of brace or support shall be provided to hold the module in the "out" or "open" position. [Source: MIL-HDBK-759B, 1992; UCRL-15673, 1985]
- **4.9.4.4 Rests and stands.** If a module contains parts that might be damaged when it is moved into position for maintenance activities, the module shall include rests or stands that protect those parts. These rests and stands shall be integral parts of the construction of the module. [Source: MIL-HDBK-759B, 1992; UCRL-15673, 1985]
- **4.9.4.5 Characteristics of straps and brackets.** Straps and brackets should:
 - a. be thick and rounded enough so that there are no sharp edges, and
 - b. be shorter than the part or module they hold so that they provide a clamping action. [Source: UCRL-15673, 1985]

- **4.9.4.6 Shock mounts.** Shock mounts should be used as appropriate to
 - a. eliminate vibration that would make displays and markings difficult to read,
 - b. reduce noise levels that might be hazardous to maintainers, and
 - c. reduce levels of vibration that might be hazardous to maintainers or equipment. [Source: UCRL-15673, 1985]
- **4.9.4.7 Preventing mounting errors by physical design.** Modules shall be designed so that it is physically impossible to mount them incorrectly. [Source: MIL-HDBK-759B, 1992; MIL-STD-1472F, 1999; NASA-STD-3000A, 1989; UCRL-15673, 1985]

Discussion. Incorrect mounting includes reversal, mismatching, and misaligning. Measures to prevent incorrect mounting include (a) the incorporation of keys or other aligning devices, (b) the provision of asymmetrical mounting brackets, and (c) the provision of asymmetrical mounting holes. Exhibit 4.9.4.7 illustrates all three of these measures. [Source: MIL-HDBK-759B, 1992; MIL-STD-1472F, 1999; NASA-STD-3000A, 1989; UCRL-15673, 1985]

Exhibit 4.9.4.7 Error-free mounting provisions
[Source: UCRL-15673, 1985]

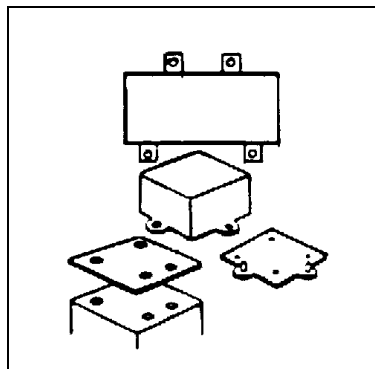

- **4.9.4.8 Mounting and orientation of similar items.** Parts and modules that are similar shall use the same mounting method and be mounted with the same orientation. [Source: MIL-STD-1472F, 1999; MIL-STD-1800A, 1990]
- **4.9.4.9 Accessibility.** Parts and modules that are intended to be removed and replaced by maintainers shall be mounted so that they can be removed without the removal of other parts or modules and without interference from other parts or modules. [Source: AFSC DH 1-3, 1980; MIL-HDBK-759B, 1992; MIL-STD-1800A, 1990]

- **4.9.4.10 Controls.** Modules shall be mounted so that it is not necessary to disconnect controls that may be needed for maintenance. [Source: AFSC DH 1-3, 1980]
- **4.9.4.11 Common hand tools.** Modules shall be designed so that they are replaceable by hand or with common hand tools. [Source: AFSC DH 1-3, 1980]
- **4.9.4.12 Front access.** Modules designed to be replaceable should be accessible through the front surface of the equipment rather than the back. [Source: AFSC DH 1-3, 1980; NASA-STD-3000A, 1989]
- **4.9.4.13 Orientation of modules within cases.** If a module has a case, the proper orientation of the module within its case shall be obvious, preferably through the physical design of the case, rather than through labeling. [Source: MIL-STD-1472F, 1999]
- **4.9.4.14 "Plug-in" connectors.** Electrical connections between modules shall be made using plug-in connectors unless special requirements, such as holding power or sealing, dictate another type. [Source: AFSC DH 1-3, 1980; MIL-STD-1472F, 1999; NASA-STD-3000A, 1989]

4.9.5 Labeling and marking

- **4.9.5.1 When to use labels and markings.** Labels or markings shall be used to
 - a. outline and identify functional groups of parts,
 - b. identify each part by name or symbol,
 - c. indicate direction of current or signal flow to aid troubleshooting, and
 - d. if applicable, identify the value and tolerance level of parts. [Source: UCRL-15673, 1985; MIL-HDBK-759B, 1992]
- **4.9.5.2 Location of labels and markings -- consistency.** Labels and markings shall be placed consistently in relation to the parts to which they refer. This placement may be on or immediately adjacent to the part. [Source: UCRL-15673, 1985]
- **4.9.5.3 Location of labels and markings -- eye level.** If the part being labeled or marked will be below eye level in its installed position, the label or mark should be above the item; if the item will be above eye level, the label or mark should be below the item. [Source: UCRL-15673, 1985]
- **4.9.5.4 Visibility.** Labels and markings shall be placed so that the maintainer can see them without having to move or remove anything. [Source: UCRL-15673, 1985]

- **4.9.5.5 Orientation.** Labels shall be horizontally oriented so that the maintainer can read them while the module is in its installed position. [Source: UCRL-15673, 1985]
- **4.9.5.6 Electrical parts.** Small electrical parts that are attached to mounting boards (resistors and capacitors, for example) shall be labeled or marked on the mounting boards. [Source: UCRL-15673, 1985]
- **4.9.5.7 Parts requiring identification.** The following parts shall be identified with labels or markings on the parts themselves or on the chassis or board adjacent to the part:
 - a. all parts identified by designations in drawings, schematics, and parts descriptions of the module,
 - b. all wires, sockets, plugs, receptacles, and similar parts having designations in wiring diagrams of the module,
 - c. all replaceable mechanical parts,
 - d. all semi-fixed electrical items, such as fuses and ferrule-clipped resistors, and
 - e. items having critical polarity or impedance ratings. [Source: UCRL-15673, 1985]
- **4.9.5.8 Identification of terminals on terminal strips or blocks.** Terminals on terminal strips or blocks shall be identified on the terminal strip or block itself or on the chassis, adjacent to the terminals (same as Paragraphs 4.7.6.4 and 4.8.1.8.3). [Source: UCRL-15673, 1985]
- **4.9.5.9 Identification of terminals on parts.** Each terminal of a part having terminals (transformers, relays, and capacitors, for example) shall be identified adjacent to the terminal. [Source: UCRL-15673, 1985]
- **4.9.5.10 Identification of parts accessible from both sides.** Receptacles for plugs and other parts that are accessible from both sides of a board or panel shall be identified on both sides. [Source: UCRL-15673, 1985]
- **4.9.5.11 Adequacy of markings.** Markings shall be sufficient to identify a part or component. [Source: UCRL-15673, 1985]
- **4.9.5.12 Durability of markings.** Markings shall be durable enough to last the life of the equipment. [Source: UCRL-15673, 1985]
- **4.9.5.13 Marking stacked parts.** If parts or modules are stacked, marking shall permit identification of the individual parts or modules. [Source: UCRL-15673, 1985]
- **4.9.5.14 Marking enclosed parts.** If a part or module is enclosed or shielded, the marking shall be placed outside the enclosure or shield. [Source: UCRL-15673, 1985]

- **4.9.5.15 Designation of parts.** The alphanumeric designation of a part shall be in accordance with MIL-STD-16 or comparable industry standards. [Source: UCRL-15673, 1985]
- **4.9.5.16 Hazard warnings.** If any hazard exists in connection with a part or module, a warning or caution label shall be provided on the part or module, on the case or cover, or both. [Source: UCRL-15673, 1985]
- **4.9.5.17 Labeling symmetric parts.** Parts that are symmetric in shape shall be labeled or marked to indicate the proper orientation for mounting. [Source: MIL-HDBK-759B, 1992]
- **4.9.5.18 Auxiliary information for parts.** Parts to which auxiliary information applies (for example, values and tolerances of resistors and capacitors) shall be labeled with that information. Preferably this information will be in alphanumeric, not coded, form. [Source: UCRL-15673, 1985; MIL-HDBK-759B, 1992]

4.10 Adjustment controls

Rules for accessing, adjusting, sequencing, and reading adjustment controls are given in this section.

- **4.10.1 Controls and feedback.** Each adjustment control shall provide feedback. This feedback might be visual, audible, or tactile. [Source: MIL-STD-1800A, 1990]
- **4.10.2 Simultaneous access to controls and displays.** Maintainers shall have simultaneous access to an adjustment control and its associated display or other source of feedback; that is, they shall be able to observe the effects of adjustments as they are made. [Source: UCRL-15673, 1985]
- **4.10.3 Location of adjustment controls.** All the adjustment controls for a module or unit of equipment should be located on a single surface, preferably the front panel or face of the equipment. [Source: MIL-HDBK-759B, 1992]
- **4.10.4 Differentiating maintenance controls from operational controls.** When maintenance and operation of a unit of equipment are performed by different sets of people, the maintenance and operational controls should not appear on the same panel. If maintenance and operational controls do appear on the same panel, the maintenance controls should be grouped and separated from the operational controls. If appropriate, the maintenance controls might also be guarded with removable covers so as not to interfere with the operator's performance. [Source: UCRL-15673, 1985; NASA-STD-3000A, 1989]
- **4.10.5 Independence of adjustment controls.** Where possible and practical, the adjustment of one control shall be independent of the adjustments of other controls. [Source: MIL-HDBK-759B, 1992]

- **4.10.6 Sequential adjustments.** If the adjustment of one control affects the adjustment of another, the controls shall be arranged in sequential order, and labeled or marked to indicate the order of adjustment. [Source: MIL-HDBK-759B, 1992]
- **4.10.7 Functionally related adjustments.** If a maintenance task consists of adjusting several functionally related variables, a single control with a switch for selecting the particular function should be provided so that the maintainer can select the functions in sequence and make adjustments with the same control. [Source: UCRL-15673, 1985]
- **4.10.8 Direct readings.** If a maintenance task requires adjusting a control to achieve a certain value or range of values, the display shall permit direct reading of the value or range; the maintainer shall not have to convert or transform the reading. [Source: MIL-HDBK-759B, 1992]
- **4.10.9 Knob adjustments preferred to screwdriver adjustments.** Knob adjustments should be used rather than screwdriver adjustments, especially if the adjustment is made more than once a month. [Source: MIL-HDBK-759B, 1992; MIL-STD-1472F, 1999; MIL-STD-1800A, 1990]
- **4.10.10 Screwdriver adjustments -- preventing slipping.** When screwdriver adjustment controls are used, a positive means, such as guides or slots, shall be provided to prevent the screwdriver tip from slipping. [Source: MIL-STD-1800A, 1990]
- **4.10.11 Screwdriver guides.** If a screwdriver adjustment must be made without the maintainer being able to see the control, or if the control is located near a high voltage, screwdriver guides shall be provided (see Paragraph 4.6.3.2.4). [Source: MIL-STD-1472F, 1999; UCRL-15673, 1985]
- **4.10.12 Use of mirrors or flashlights.** Maintainers shall not have to use mirrors or flashlights in making adjustments. [Source: MIL-STD-1472F, 1999]
- **4.10.13 Remote adjustments.** If it is not practical to provide access to an internally located control, a remote control should be provided. [Source: UCRL-15673, 1985]
- **4.10.14 Degree of adjustment.** Controls shall accommodate the degree of adjustment required, that is, gross adjustment, fine adjustment, or both. [Source: MIL-STD-1800A, 1990]
- **4.10.15 Mechanical stops.** Adjustment controls intended to have a limited range of motion shall have mechanical stops; these stops shall be capable of withstanding a force or torque 100 times greater than the resistance to movement within the range of adjustment. [Source: MIL-STD-1472F, 1999; MIL-STD-1800A, 1990]
- **4.10.16 Preventing inadvertent adjustment.** Adjustment controls shall be located and mounted so that they cannot be adjusted inadvertently by the maintainer. [Source: MIL-HDBK-759B, 1992]

- **4.10.17 Critical or sensitive adjustments.** Critical or sensitive adjustments shall incorporate features, such as locking devices, to prevent inadvertent or accidental adjustment. If a locking device is used, operation of the locking device shall not change the adjustment setting. [Source: MIL-STD-1472F, 1999]
- **4.10.18 Hand or arm support.** If an adjustment control or the maintainer will be subjected to disturbing vibration during adjustment, a suitable hand or arm support shall be provided. [Source: MIL-STD-1472F, 1999]
- **4.10.19 Avoidance of hazards.** Adjustment controls shall not be located close to dangerous voltages, moving machinery, or other hazards. If a hazardous location cannot be avoided, the controls shall be appropriately labeled, shielded, and guarded. [Source: MIL-STD-1472F, 1999; MIL-STD-1800A, 1990]

4.11 Fuses and circuit breakers

This section contains rules for systems that use fuses and circuit breakers. General rules address the selection and use of fuses and circuit breakers, the design characteristics of fuses, push-pull circuit breakers, toggle bat and legend switch circuit breakers, and the labeling of fuses and circuit breakers.

4.11.1 General

- **4.11.1.1 Selection of fuses and circuit breakers.** Fuses and circuit breakers should be selected so that they are appropriate to the particular function they will perform. Exhibit 4.11.1.1 lists the appropriate type of fuse or circuit breaker for a variety of functions. [Source: MIL-HDBK-759B, 1992]

Discussion. When selecting fuses or circuit breakers, consider the suitability of each to perform a particular function. There are two types of circuit breakers, thermal air and magnetic air. Thermal air circuit breakers are used primarily for overcurrent circuit protection. They are best adapted to dc circuits up to 250 volts, and to ac circuits up to 600 volts in capacities up to 600 amperes. Magnetic air circuit breakers may be used to provide protection in event of overcurrent, undercurrent, reverse current, low voltage, and reverse phase. [Source: MIL-HDBK-759B, 1992]

Exhibit 4.11.1.1 General comparison of fuses and circuit breakers

Function	Fuse	Thermal air	Magnetic air
Instantaneous action	X		X
Time delay features	X	X	X
Resetting		X	X
Adjustable tripping range for other than maximum			X
Automatic resetting			X
Remote control resetting and tripping			X
Overcurrent protection	X	X	X
Low current, reverse current, and low voltage protection			X

- **4.11.1.2 Location of fuses and circuit breakers.** Fuses and circuit breakers shall be grouped in a minimum number of centralized, readily accessible locations for removal, replacement, and resetting. [Source: NASA-STD-3000A, 1989; MIL-STD-1472F, 1999; MIL-HDBK-759B, 1992]
- **4.11.1.3 Verification of an open circuit.** An indication shall be provided when a fuse or circuit breaker has opened a circuit. [Source: MIL-STD-1472F, 1999; MIL-STD-1800A, 1990; NASA-STD-3000A, 1989]
- **4.11.1.4 Individual fused units.** Fuses or circuit breakers should be provided so that each unit of a system is separately fused and adequately protected from harmful variations in voltages. [Source: MIL-HDBK-759B, 1992]

4.11.2 Fuses

- **4.11.2.1 Using fuses.** Fuses shall conform to MIL-F-15160. [Source: MIL-HDBK-759B, 1992]
- **4.11.2.2 Worker safety.** Fuse installations shall be designed so that only the "cold" terminal of the fuse can be touched by maintenance personnel. [Source: MIL-HDBK-759B, 1992]

- **4.11.2.3 Safeguarding the circuit.** Fuses shall be provided that safeguard the circuit if the wrong switch or jack position is used. [Source: MIL-HDBK-759B, 1992]
- **4.11.2.4 Quick-disconnect fuse holders.** Fuse holder cups or caps should be of the quick-disconnect type rather than the screw-in type; they should be knurled and large enough to be removed easily by hand. [Source: MIL-HDBK-759B, 1992]
- **4.11.2.5 No special tools for fuse replacement.** Fuse replacement shall not require special tools, unless they are needed for safety. [Source MIL-STD-1800A, 1990; MIL-STD-1472F, 1999; AFSC DH 1-3, 1980]
- **4.11.2.6 No other components to be removed.** Fuses shall be located so they can be replaced without removing any other components. [Source: MIL-HDBK-759B, 1992; MIL-STD-1800A, 1990; AFSC DH 1-3, 1980; MIL-STD-1472F, 1999]
- **4.11.2.7 Spare fuse provisions.** Spare fuses and holders for them shall be provided and located near fuse holders. Labels adjacent to these spare fuse holders shall contain the word "SPARE" and shall state the fuse values and functions. [Source: MIL-HDBK-759B, 1992; MIL-STD-1472F, 1999; MIL-STD-1800A, 1990]
- **4.11.2.8 Anticorrosion precautions.** A silicon electrical lubricating compound should be applied to the fuse and the interior of the fuse holder. The exterior of the fuse holder (except contact surfaces) should be coated with fungicidal varnish. Sealed fuses should be used. [Source: MIL-HDBK-759B, 1992]

4.11.3 Push-pull circuit breakers

- **4.11.3.1 Push-pull circuit breaker specifications.** Push-pull actuated circuit breaker dimensions, displacement, and separation shall conform to Exhibit 4.11.3.1. [Source: MIL-STD-1472F, 1999]

Exhibit 4.11.3.1 Push-pull circuit breaker specifications

[Source: MIL-STD-1472F; MIL-HDBK-759B, 1992; MIL-STD-1800A]

	<p>Push-pull control, low resistance, for two-position, mechanical and electrical systems. Alternate three position plus rotary function acceptable for application such as vehicle headlight plus parking lights, panel and dome lights. Provide serrated rim.</p>			
<p>D. Minimum diameter 19 mm (0.75 in)</p>	<p>C. Minimum clearance 25 mm (1.0 in) add 13 mm (0.5 in) for gloved hand</p>	<p>12-38 mm (0.5-1.5 in) Minimum between pull positions: 13 mm (0.5 in)</p>	<p>S. Minimum space between: 38 mm (1.5 in) add 13 mm (0.5 in) for gloved hand</p>	
	<p>Alternate handle; miniature electrical panel switch only. Avoid glove use application.</p>			
<p>D. Minimum diameter: 6.5 mm (0.25 in)</p>	<p>L. Minimum length 19 mm (0.75 in)</p>	<p>Minimum: 13 mm (0.5 in)</p>	<p>S. Minimum space between: 25 mm (1 in)</p>	
	<p>High-force push-pull, for two-position mechanical system only.</p>			
<p>W. Minimum width: 100 mm (4 in)</p>	<p>D. Depth: 16-38 mm (0.6-1.5 in)</p>	<p>C. Minimum clearance: 38 mm (1.5 in) add 6 mm (0.24 in) for gloved hand</p>	<p>Minimum 25 mm (1 in) Preferred: 50 mm (2 in)</p>	
	<p>Same as above. Preferred where possible garment or cable-s snag possibility exists.</p>			
<p>W. Minimum width: 100 mm (4 in)</p>	<p>D. Depth: 16-38 mm (0.6-1.5 in)</p>	<p>C. Minimum clearance 38 mm (1.5 in)</p>	<p>Minimum: 25 mm (1 in) Preferred: 50 mm (2 in)</p>	<p>S. Minimum space between: 13 mm (0.5 in)</p>
<p>Note. 1 and 2 finger pulls also acceptable for less than 18 N (4.0 lb) application</p>				

- 4.11.3.2 **Power switches.** Push-pull type circuit breakers shall not be used as power switches. [Source: MIL-STD-1472F, 1999; MIL-STD-1800A, 1990]

4.11.4 Toggle bat and legend switch circuit breakers

Toggle bat and legend switch actuated circuit breakers may be used to control electrical power. [Source: MIL-STD-1472F, 1999]

- 4.11.4.1 Toggle bat specifications.** Dimensions, resistance, displacement, and separation for toggle bat actuated breakers shall comply with Exhibit 4.11.4.1. [Source: MIL-STD-1472F, 1999; MIL-STD-1800A, 1990]

Exhibit 4.11.4.1 Toggle bat specifications

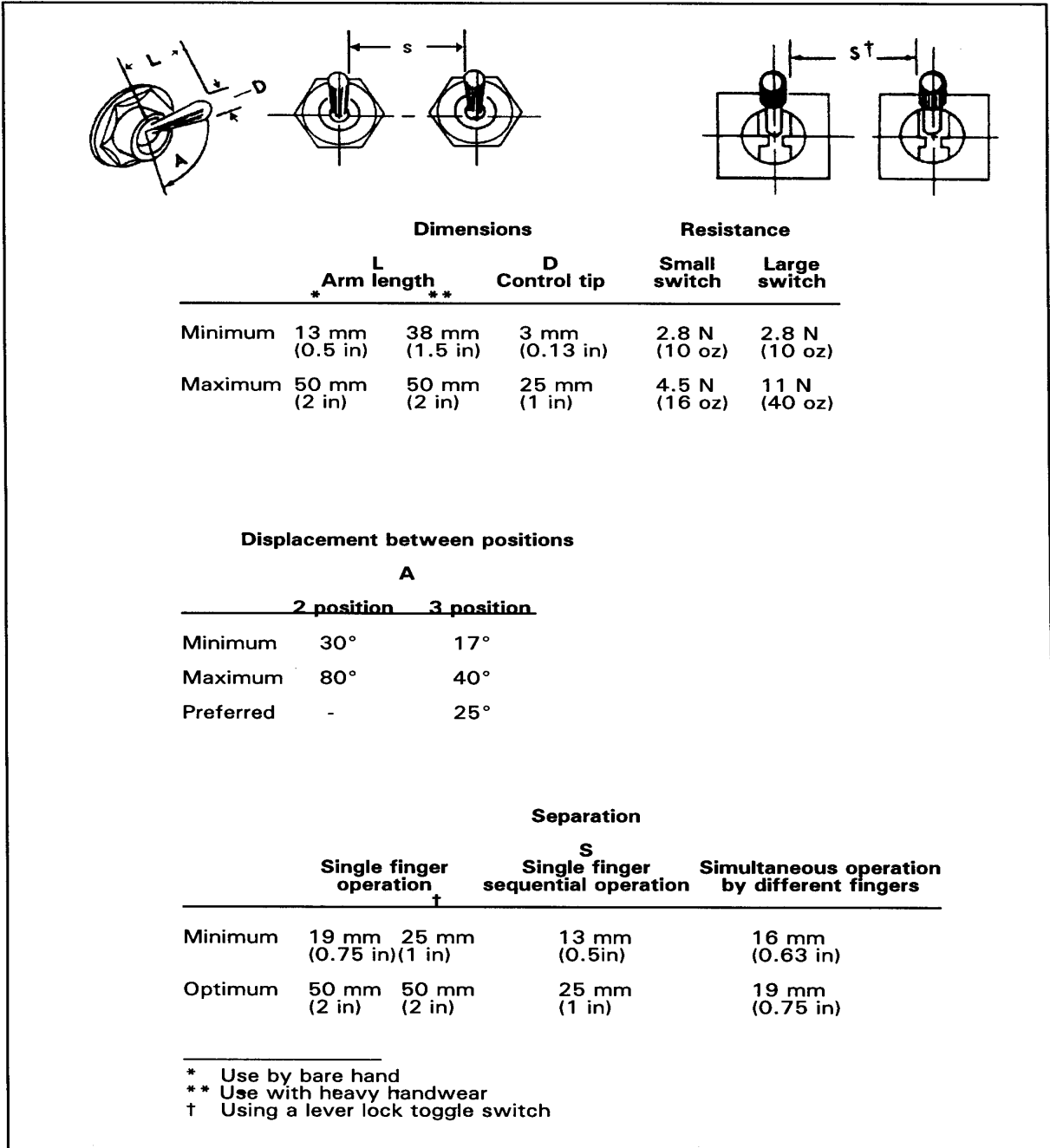

- 4.11.4.2 Legend switch specifications.** Legend switch actuated breakers shall comply with the dimension, displacement, separation, and resistance criteria shown in Exhibit 4.11.4.2. [Source: MIL-STD-1472F, 1999; MIL-STD-1800A, 1990]

Exhibit 4.11.4.2 Legend switch specifications. [Source: MIL-STD-1472F; MIL-STD-1800A]

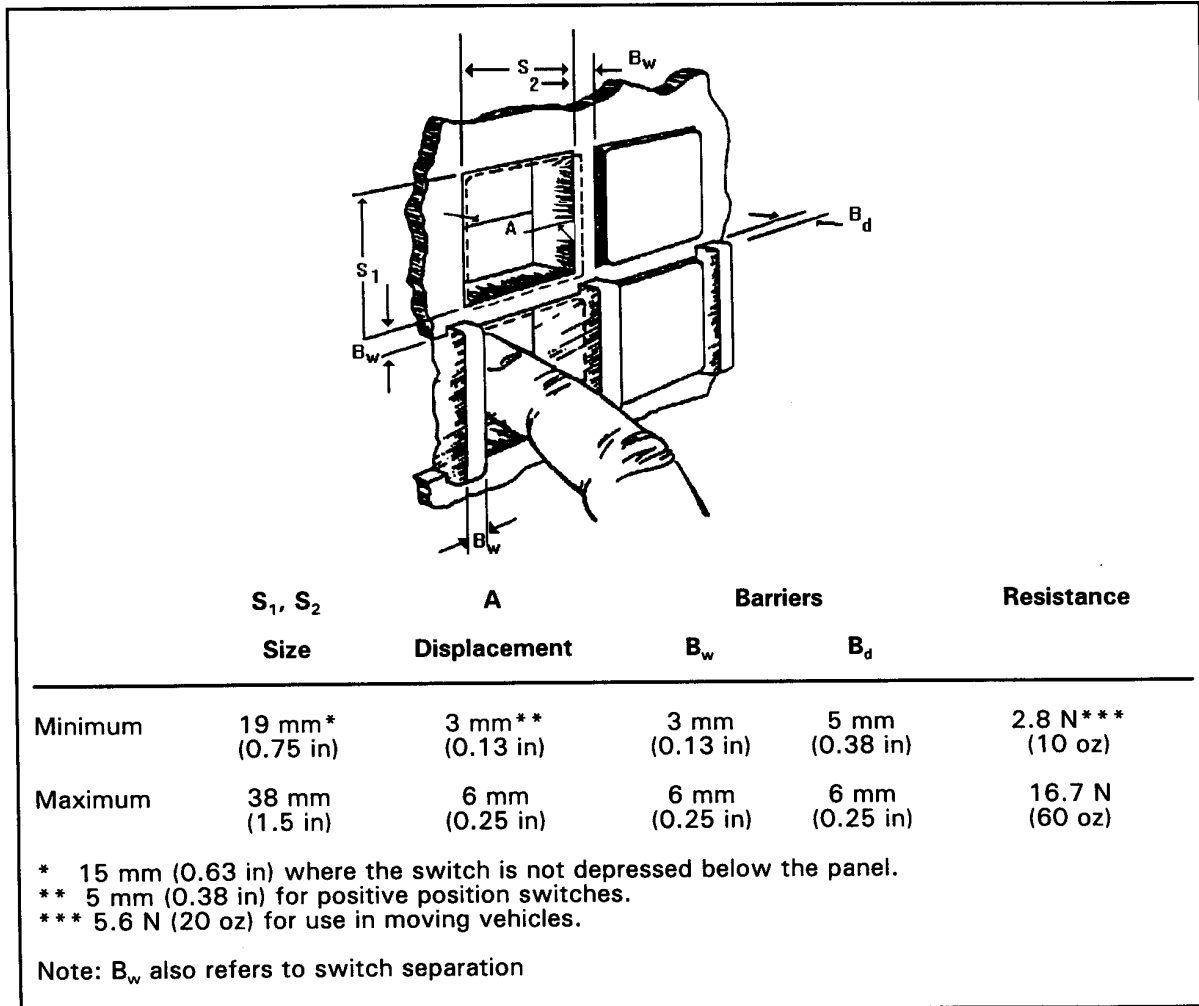

4.11.5 Labeling and marking

- **4.11.5.1 Fuses and circuit breakers.** Fuses and circuit breakers shall be permanently labeled or marked. The labeling or marking shall be legible in the anticipated ambient illumination range for the maintainer's location. [Source: MIL-STD-1472F, 1999; MIL-STD-1800A, 1990]
- **4.11.5.2 Fuse ratings.** A fuse's rating shall be indicated adjacent to the fuse. The rating shall be in whole numbers, common fractions, such as $1/2$, or whole numbers and common fractions, such as $2\ 1/2$. [Source: MIL-HDBK-759B, 1992; MIL-STD-1472F, 1999]
- **4.11.5.3 Circuits.** The area of equipment served by a fuse or circuit breaker shall be identified. [Source: MIL-STD-1800A, 1990; MIL-STD-1472F, 1999]

4.12 Test points and service points

Strategically placed test points make signals available to maintenance personnel for checking, adjusting, and troubleshooting. Test points are recommended for units of equipment that are not completely self-checking. [Source: UCRL-15673, 1985]

Definition. Test points are a means for conveniently and safely determining the operational status of equipment and for isolating malfunctions. **Service points** are a means for lubricating, filling, draining, charging, and performing other service functions. They permit the routine performance of these services on all equipment and components requiring them. [Source: UCRL-15673, 1985]

4.12.1 Adjustment controls

- **4.12.1.1 Location.** An adjustment control associated with a test point shall be located near the test point and shall provide a signal at the test point that indicates clearly when the correct adjustment has been achieved. [Source: AFSC DH 1-3, 1980; MIL-HDBK-759B, 1992]
- **4.12.1.2 Individual adjustment controls.** A test point should not have more than one associated adjustment control. [Source: AFSC DH 1-3, 1980]

4.12.2 Location and arrangement

- **4.12.2.1 Test points for units of equipment.** A test point should be provided for each input to and output from a unit of equipment. [Source: AFSC DH 1-3, 1980]
- **4.12.2.2 Arranging test points.** When testing complexity warrants, test points shall be arranged on a single control panel or on a series of functionally autonomous panels. [Source: UCRL-15673, 1985; AFSC DH 1-3, 1980]
- **4.12.2.3 Tracing signals.** Test points should be provided to permit the systematic tracing of signals and voltages through a unit of equipment. These test points allow a maintainer to determine the point at which signals or voltages in a malfunctioning unit are out of tolerance. [Source: AFSC DH 1-3, 1980]
- **4.12.2.4 Test and service point accessibility.** All test and service points shall be physically and visually accessible to the maintainer. [Source: MIL-HDBK-759B, 1992]
- **4.12.2.5 Proximity to associated controls and displays.** Test and service points shall be located in physical and visual proximity to the controls and displays used to make the adjustments associated with the points. [Source: NASA-STD-3000A, 1989; MIL-STD-1472F, 1999; UCRL-15673, 1985]
- **4.12.2.6 Test and service point location.** Test and service points should be provided, designed, and located in accordance with their frequency of use and any applicable time limits on maintenance activities. [Source: MIL-HDBK-759B, 1992]
- **4.12.2.7 Minimizing testing and servicing.** Requirements for periodic or repetitive testing and servicing of components should be avoided if possible by using sealed bearings, oil impregnated bushings, highly reliable components, and the like. [Source: UCRL-15673, 1985]
- **4.12.2.8 Minimizing test and service points.** To reduce the number of test and service points required, built-in indicators, center reading meters, pressure gauges, direct reading fluid level gauges, and the like shall be used for quick checks, thus avoiding the need for auxiliary equipment. [Source: UCRL-15673, 1985]
- **4.12.2.9 Avoid isolated test or service points.** Isolated test or service points should be avoided; such points are likely to be overlooked or neglected. [Source: MIL-HDBK-759B, 1992]
- **4.12.2.10 Compatibility of test and service points.** Test and service points shall be designed for compatibility with checking, troubleshooting, and servicing procedures and with test and service equipment. [Source: UCRL-15673, 1985]

- **4.12.2.11 Distinctive connections.** Distinctively different connectors or fittings should be provided for each type of test or service equipment (for example, grease and oil fittings should be distinctively different from each other) to minimize the likelihood of error. [Source: MIL-HDBK-759B, 1992]
- **4.12.2.12 Avoid separate accessories.** Separate funnels, strainers, adapters, and other accessories should be avoided. Where practical, these accessories should be built into the equipment or the service equipment, so that they need not be handled separately. [Source: MIL-HDBK-759B, 1992]
- **4.12.2.13 Terminal strips.** If special test points are not provided on electrical equipment, cables should be fanned out on terminal strips as illustrated in Exhibit 4.12.2.13. [Source: UCRL-15673, 1985]

Exhibit 4.12.2.13 Terminal strips

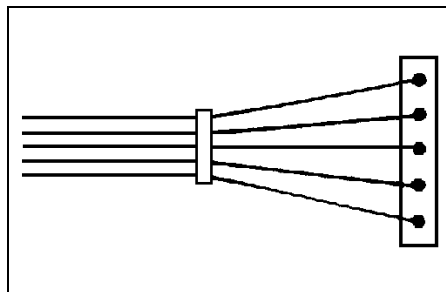

4.12.3 Drain points

- **4.12.3.1 Drain provisions.** Drains shall be provided on all fluid tanks and systems, fluid filled cases, filter systems, float chambers, and other items that are likely to contain fluid that would otherwise be difficult to remove. [Source: UCRL-15673, 1985]
- **4.12.3.2 Minimization.** The number of types and sizes of drain fittings should be minimized and standardized throughout the system. [Source: UCRL-15673, 1985]
- **4.12.3.3 Valves and petcocks versus drain plugs.** Whenever practical, valves or petcocks should be used rather than drain plugs. [Source: UCRL-15673, 1985]
- **4.12.3.4 Drain plugs.** Drain plugs shall require only common hand tools for operation, and their placement shall ensure adequate tool and work clearance for operation. [Source: UCRL-15673, 1985]
- **4.12.3.5 Labels.** Drain cocks or valves shall be clearly labeled to indicate open and closed positions, and the direction of movement required for opening. [Source: UCRL-15673, 1985]
- **4.12.3.6 Drain cock motions.** Drain cocks shall always close with clockwise motion and open with counterclockwise motion. [Source: UCRL-15673, 1985]

- **4.12.3.7 Instruction labels.** Instruction labels shall be provided, as necessary, to ensure that the fluid system is properly prepared prior to draining. [Source: UCRL-15673, 1985]
- **4.12.3.8 Accessibility.** As applicable, drain points shall be designed, located, and installed
 - a. where they are reachable and operable by the maintainer,
 - b. so that fluid will not drain or spill on equipment or personnel,
 - c. at the lowest point in the system if complete draining is required,
 - d. to permit selective draining or bleeding to facilitate maintenance procedures,
 - e. to permit drainage directly into a waste container without use of separate adapters or piping, and
 - f. so that fuel or other combustible fluids cannot run down to or collect in hazardous areas. [Source: UCRL-15673, 1985]

4.12.4 Accessibility

- **4.12.4.1 Test and service point accessibility.** Test and service points shall be easily accessible for checking and troubleshooting. Recommended minimum clearances are 19 mm (0.75 in) when only finger control is required, and 75 mm (3 in) when the gloved hand is used. [Source: UCRL-15673, 1985; AFSC DH 1-3, 1980]
- **4.12.4.2 Test probe guides.** Suitable guides for test probes should be provided when test points are located internally. [Source: UCRL-15673, 1985]
- **4.12.4.3 Test accesses.** Test accesses should be provided for mechanical components likely to wear. For example, brake assemblies should be provided with an inspection opening to permit insertion of a gauge for determining the clearance between the brake lining and drum. [Source: UCRL-15673, 1985; AFSC DH 1-3, 1980]

- **4.12.4.4 Test points in plugs.** If appropriate, plugs with integral test points for each input and output shall be used. If dust or moisture is a factor, an integral sliding cover for the test points shall be provided on the plug, as shown in Exhibit 4.12.4.4 (a). An acceptable alternative is the provision of a test-point adapter for insertion between a plug and its receptacle, as shown in Exhibit 4.12.4.4 (b). [Source: AFSC DH 1-3, 1980]

Exhibit 4.12.4.4 (a) Test plug with sliding cover

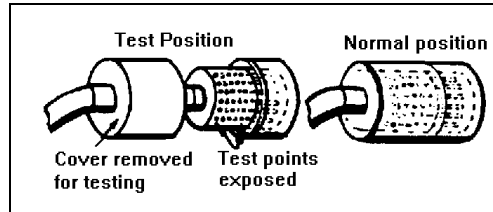

[Source: AFSC DH 1-3, 1980; UCRL-15673, 1985]

Exhibit 4.12.4.4 (b) Test point adapter

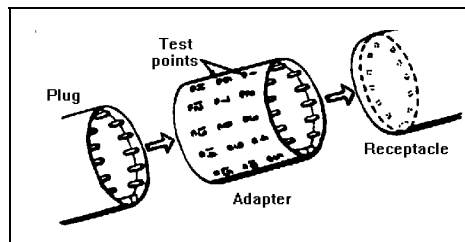

[Source: AFSC DH 1-3, 1980; UCRL-15673, 1985]

4.12.5 Safety

- **4.12.5.1 Test point shielding.** All test points shall be located or shielded to protect the maintainer against contact with high voltages. [Source: AFSC DH 1-3, 1980]
- **4.12.5.2 Minimum clearance.** Test and service points shall be separated by more than a hand's width, 114 mm (4.5 in), from the nearest hazard. [Source: UCRL-15673, 1985]
- **4.12.5.3 Recessed test and service points.** Test and service points should be recessed to protect them from damage by personnel, dust, moisture, and the like. [Source: UCRL-15673, 1985]
- **4.12.5.4 High pressure test indicators.** High pressure test indicators should be used wherever possible to avoid some of the hazards associated with making temporary high pressure connections. [Source: UCRL-15673, 1985]

- **4.12.5.5 Ground points.** If a good grounding point is not available, a special "ground" point shall be provided. Connection to this special ground point shall be made during tests of a given unit. [Source: UCRL-15673, 1985]

Discussion. Maintainers may have difficulty if only painted surfaces are available for ground connections. [Source: UCRL-15673, 1985]

- **4.12.5.6 Shields around lubrication points.** Shields should be provided around lubrication points that may be serviced while equipment is operating. [Source: UCRL-15673, 1985]

4.12.6 Labeling, marking, and coding

- **4.12.6.1 Label location.** Labels for test and service points shall be in full view of the maintainer making connections or adjustments. [Source: UCRL-15673, 1985]
- **4.12.6.2 Distinguishable marking.** Test and service points shall be designed and marked so that they are easily distinguishable, for example, by coding them with distinctive colors. [Source: UCRL-15673, 1985; AFSC DH 1-3, 1980]
- **4.12.6.3 Distinguishing test and service points.** If color-coding is used, the color of test points shall be clearly different from the color of service points. [Source: UCRL-15673, 1985]
- **4.12.6.4 Hazardous points.** Hazardous test and service points shall be labeled to warn maintainers about any possible injury to themselves or damage to internal circuits. [Source: NASA-STD-3000A, 1989; UCRL-15673, 1985]
- **4.12.6.5 Identification of test points.** Each test point shall be clearly labeled with a number, letter, symbol, or description of its function or, at a minimum, with a code number keyed to the user documentation. [Source: NASA-STD-3000A, 1989; AFSC DH 1-3, 1980]
- **4.12.6.6 Luminescent markings.** If test points must be read under very low ambient illumination, they should be marked in phosphorescent colors. [Source: AFSC DH 1-3, 1980]
- **4.12.6.7 Tolerance limits.** Each test point should be labeled with the tolerance limits of the signal to be measured there. [Source: AFSC DH 1-3, 1980]
- **4.12.6.8 Internal test and service points.** When a test or service point is located internally, its location shall be indicated on the cover or adjacent to its access opening on the surface of the equipment. [Source: UCRL-15673, 1985]

4.13 Test equipment

This section contains general rules for test equipment and specific rules for four types of test equipment: (a) built-in, (b) go, no-go, (c) automatic, and (d) collating. Bench mockups and storage for test equipment are also addressed.

Definitions. **Built-in test equipment** is an integral part of a unit of equipment and can range from a simple voltmeter to a complex automatic checker. **Go, no-go test equipment** provides one of two alternative answers to any question. For example, it tells whether a given signal is in or out of tolerance. **Automatic test equipment** checks two or more signals in sequence without the intervention of a maintainer. The test usually stops when the first out-of-tolerance signal is detected. **Collating test equipment** presents the results of two or more checks as a single display; for example, a light might come on only if a number of different signals are in tolerance. [Source: AFSC DH 1-3, 1980; UCRL-15673, 1985]

4.13.1 General

Test equipment is intended to (a) simplify the job of the maintainer, (b) reduce the preparation or turn-around time for installing, maintaining, and repairing systems, and (c) reduce total maintenance costs. It needs to be fast, easy, and safe to use.

The type of test equipment is decided upon in the early stages of equipment design. Selection of test equipment depends on (a) the mission and operational characteristics of the equipment, (b) the anticipated reliability of the equipment, (c) the maintenance concept, (d) the available personnel, (e) the operational environment, (f) the logistics support requirements, and (g) the development time and cost. [Source: UCRL-15673, 1985]

4.13.1.1 General characteristics

The following general rules are aimed at simplifying the maintainers' job.

- **4.13.1.1.1 Test equipment treatment.** Test equipment and bench mockups shall be treated like any other equipment with respect to design requirements for units, covers, cases, cables, connectors, test points, displays, and controls. [Source: UCRL-15673, 1985, 1.8.2]
- **4.13.1.1.2 Accuracy of test equipment.** The accuracy of all test equipment shall exceed that of the equipment being tested. [Source: NASA-STD-3000A, 1989]
- **4.13.1.1.3 Conversion tables.** Conversion tables shall not be used in deciding if equipment is within tolerances. [Source: UCRL-15673, 1985]

- **4.13.1.1.4 Selector switches.** Selector switches should be used rather than multiple plug-in connections as long as the effects of switching do not degrade the desired information. [Source: AFSC DH 1-3, 1980; UCRL-15673, 1985]

Discussion. Selector switches can be used more quickly than plug-in connections, and they reduce the likelihood of faulty connections. [Source: AFSC DH 1-3, 1980; UCRL-15673, 1985]

- **4.13.1.1.5 Maintenance instructions.** Clear operating and maintenance instructions shall be prepared and available to the maintainer. [Source: AFSC DH 1-3, 1980]
- **4.13.1.1.6 Storing instructions.** Full instructions shall be stored inside the test equipment's cover or case, if any, or attached to a metal plate containing a checklist for operating the equipment. [Source: AFSC DH 1-3, 1980]
- **4.13.1.1.7 Labeling.** The outer case and all removable parts should be clearly labeled with the equipment identification, including its purpose and any precautions that should be observed in using it. [Source: AFSC DH 1-3, 1980]
- **4.13.1.1.8 Label contents.** The label shall contain all items the maintainer must be able to recognize, read, or use. [Source: AFSC DH 1-3, 1980]

4.13.1.2 Safety

- **4.13.1.2.1 Shielding hazardous parts.** Test equipment shall be designed so that all exposed moving and cutting parts are shielded to prevent maintainer injuries during maintenance tasks. [Source: UCRL-15673, 1985]
- **4.13.1.2.2 Minimizing hazards.** When possible, fail-safe features should be incorporated in test equipment to minimize any danger to maintainers or equipment. [Source: UCRL-15673, 1985]
- **4.13.1.2.3 Internal controls.** Internal controls shall be located away from dangerous voltages. [Source: UCRL-15673, 1985]
- **4.13.1.2.4 Safeguarding high voltages.** High voltage areas shall be insulated or shielded. [Source: UCRL-15673, 1985]
- **4.13.1.2.5 Warning labels.** Adequate warnings shall be provided wherever potential hazards exist. [Source: UCRL-15673, 1985]

4.13.1.3 Ease of use

- **4.13.1.3.1 Accessibility.** Adjustment points, test points, cables, connectors, and labels for all required maintenance tasks shall be visually and physically accessible. Access openings necessary to connect test equipment using required tools shall accommodate maintainers and equipment as specified in Paragraph 4.4.3 and Paragraph 4.12.4.1. [Source: MIL-STD-1800A, 1990]

- **4.13.1.3.2 Minimizing test equipment.** The number and types of test equipment and accessories, such as connectors and test cables, should be minimized. [Source: UCRL-15673, 1985]
- **4.13.1.3.3 Ease of use.** Equipment should be simple to operate, have self-checking and calibrating features, and have a minimum number of controls and displays. [Source: AFSC DH 1-3, 1980; UCRL-15673, 1985]
- **4.13.1.3.4 Reducing the number and complexity of steps.** The number and complexity of steps should be reduced by grouping controls (such as by sequence or criticality) or by making certain operations automatic. [Source: AFSC DH 1-3, 1980]
- **4.13.1.3.5 Individual operation.** Test equipment should be designed for operation by one person. [Source: UCRL-15673, 1985]

4.13.1.4 Controls and displays

- **4.13.1.4.1 Calibration check.** Test equipment should be easily calibrated or equipped with a simple check (for example, a go, no-go indicator) to indicate whether or not the test equipment is out of calibration or is malfunctioning. [Source: AFSC DH 1-3, 1980; UCRL-15673, 1985]
- **4.13.1.4.2 Warm-up indicators.** A warm-up indicator should be provided, if applicable, to show when the test equipment is warmed up and ready to use. If such a signal cannot be provided, a label near the warm-up switch should state clearly how much warm-up time is required. [Source: UCRL-15673, 1985; AFSC DH 1-3, 1980]
- **4.13.1.4.3 Automatic shutoff switches.** If feasible, test equipment should have an automatic shutoff. If it is not feasible, test equipment should have both warning lights and written warnings to remind the maintainer to turn the equipment off when finished. [Source: UCRL-15673, 1985]
- **4.13.1.4.4 Misalignment.** Controls and displays should be designed to prevent misalignment that might be caused by vibration, service use, or accidental contact. [Source: UCRL-15673, 1985]

4.13.2 Built-in test equipment (and partially built-in, portable, and test panels)

The advantages of built-in test equipment include (a) being less likely than portable test equipment to be lost or damaged, (b) being available when needed, and (c) requiring no special storage facilities.

The disadvantages of built-in test equipment include (a) adding to the weight and space requirements of the equipment being tested, (b) requiring more built-in test equipment because a separate item is usually required for each unit of equipment, (c) transporting built-in test equipment to a point for convenient calibration may be more difficult than transporting portable test equipment, and (d) installing test equipment permanently may increase the complexity of wiring for the system and may even increase the amount of maintenance activity.

Definition. Built-in test equipment is an integral part of a unit of equipment and can range from a simple voltmeter to a complex automatic checker.

4.13.2.1 Completely built-in test equipment

- **4.13.2.1.1 Combining test points.** If a unit of equipment has built-in test capabilities, all maintenance tests should be performed with the built-in test unit. [Source: AFSC DH 1-3, 1980]
- **4.13.2.1.2 Efficiency.** If possible, built-in test units should be integrated into the equipment for efficient maintenance and troubleshooting. [Source: UCRL-15673, 1985]

Discussion. If voltages and wave shapes must be checked, for example, the test unit might consist of a meter, an oscilloscope, and a rotary switch for selecting circuits. [Source: UCRL-15673, 1985]

- **4.13.2.1.3 Easy to use.** Meters and oscilloscopes should have fixed, preset circuits so that the meter always reads center scale and the oscilloscope requires no adjustment. [Source: UCRL-15673, 1985]
- **4.13.2.1.4 In-tolerance.** Either an in-tolerance meter reading or an in-tolerance waveshape on the oscilloscope should be coded for each position of the rotary switch. If more test points are needed than can be handled by a single switch, multiple switches can be used. [Source: UCRL-15673, 1985]

4.13.2.2 Partially built-in test equipment

- **4.13.2.2.1 Combining test points.** If possible, all test points should be incorporated into one built-in unit of test equipment. [Source: AFSC DH 1-3, 1980]

- **4.13.2.2.2 Test capabilities.** To the extent feasible, all the test capabilities described in Paragraph 4.13.2.1 should be built-in. [Source: AFSC DH 1-3, 1980; UCRL-15673, 1985]

Example. A center-reading meter might be mounted on each major component that can be checked by a meter, and a set of test jacks might be provided as an outlet for signals requiring an oscilloscope. [Source: AFSC DH 1-3, 1980; UCRL-15673, 1985]

4.13.2.3 Portable test equipment

- **4.13.2.3.1 When to use.** If it is not practical to incorporate all test points into one unit of built-in test equipment or to provide a center-reading meter and test jacks for an external oscilloscope, a portable test unit shall be provided. [Source: AFSC DH 1-3, 1980]
- **4.13.2.3.2 Single connection.** Portable test equipment shall connect to its associated unit of equipment or partially built-in test equipment through a single, multi-prong connector. [Source: NASA-STD-3000A, 1989; AFSC DH 1-3, 1980; UCRL-15673, 1985]
- **4.13.2.3.3 Internal storage.** Portable test equipment shall have enough storage space in its handling case or lid to contain leads, probes, spares, and any special tools required for operation. [Source: MIL-STD-1800A, 1990; MIL-STD-1472F, 1999]
- **4.13.2.3.4 Operating instructions.** Instructions for operating portable test equipment shall be provided on the face of the test equipment, on its case or cover, if any, or in a special storage compartment in the test. These instructions shall be easily readable by the maintainer while the test equipment is being operated. If applicable, the instructions shall include a reminder to calibrate the equipment and instructions for calibration. [Source: MIL-STD-1800A, 1990]
- **4.13.2.3.5 Calibration records.** If applicable, a placard shall be attached to the equipment for recording calibration information, including tolerance check values. [Source: MIL-STD-1472F, 1999]

4.13.2.4 Built-in test panel

- **4.13.2.4.1 When to use.** If built-in, partially built-in, or portable test units are not practical, a test panel should be provided on the equipment. [Source: UCRL-15673, 1985]
- **4.13.2.4.2 Test point connections.** Test points shall permit the connection of appropriate test equipment, such as voltage meters or oscilloscopes. [Source: UCRL-15673, 1985]
- **4.13.2.4.3 Block diagram.** The test points on a test panel should be arranged within a miniature block diagram of the system, with each block representing components or units of equipment. [Source: UCRL-15673, 1985]

- **4.13.2.4.4 Overlays.** Overlays for the test panel should be provided to direct the maintainer to test points that should be checked and the order in which they should be checked. Instructions should be provided in the user documentation. [Source: UCRL-15673, 1985]
- **4.13.2.4.5 Tolerance limits for signals.** Tolerance limits for signals should be shown on overlays, and test points should be coded on the test panel. Full instructions should be provided in user documentation so that they are still available in the event an overlay is lost. [Source: UCRL-15673, 1985]

4.13.3 Test equipment

There are three classifications of test equipment: **go/no-go test equipment**, **automatic test equipment**, and **collating test equipment**.

Definition. Go, no-go test equipment provides one of two alternative answers to any question. For example, it tells whether a given signal is in or out of tolerance.

Definition. Automatic test equipment checks two or more signals in sequence without the intervention of a maintainer. Testing usually stops when the first out-of-tolerance signal is detected.

Definition. Collating test equipment presents the results of two or more checks as a single display; for example, a "test passed" light would come on only if all of the relevant signals are in tolerance.

The advantages of go, no-go test equipment include (a) presenting information in a clear, unambiguous manner and (b) simplifying difficult tasks, such as balancing circuits and checking complex waveshapes.

The disadvantages include (a) requiring unique circuitry for each signal value to be tested (sometimes, however, ordinary displays can be converted to go, no-go displays by appropriate use of reference scales such as a colored section on a meter dial), (b) increasing the number and complexity of circuits required, which will probably add to initial cost and development time and increase the rate of test equipment breakdown, (c) providing relatively little help to the maintainer in checking common voltages or simple waveshapes, and (d) requiring a special model for many or most units of equipment. [Source: UCRL-15673, 1985]

An advantage of automatic test equipment is that it can make a rapid sequence of checks with little or no chance of omitting steps.

Disadvantages of automatic test equipment include: (a) it can be relatively expensive, large, and heavy, and it may require maintenance of itself, (b) it can be relatively specialized, with little versatility, (c) it can require self-checking features to detect test equipment malfunctioning, which adds to cost and to problems of maintaining the test equipment, and (d) it will probably require a special model for each unit of equipment. [Source: UCRL-15673, 1985; AFSC DH 1-3, 1980]

An advantage of collating test equipment is that it reduces the number of displays the maintainer must read, thereby reducing testing time and, probably, errors.

The disadvantages are similar to those for go, no-go and automatic test equipment. [Source: UCRL-15673, 1985; AFSC DH 1-3, 1980]

- **4.13.3.1 Identification of out-of-tolerance signals.** If equipment fails a test performed by collating test equipment, the test equipment should indicate which signal(s) are out of tolerance, not just that the equipment failed the test. [Source: UCRL-15673, 1985]

4.13.4 Bench mockups

- **4.13.4.1 Accessibility.** Bench mockup cables should comply with 4.8.1.7, Bench mockup cables.
- **4.13.4.2 Accessibility.** Adequate space shall be provided in the layout of a mockup to allow the maintainer to perform any required maintenance activities on the units. [Source: AFSC DH 1-3, 1980]
- **4.13.4.3 Support for test equipment.** Pullout shelves or some other method of supporting the test equipment shall be provided while the test equipment is being used. [Source: AFSC DH 1-3, 1980]
- **4.13.4.4 Test leads.** Test leads should require no more than a fraction of a turn for attachment to the equipment being maintained. [Source: AFSC DH 1-3, 1980]
- **4.13.4.5 Signal values.** The operating instructions for bench mockups shall include correct signal values and tolerances for each test point. [Source: AFSC DH 1-3, 1980]
- **4.13.4.6 Covers.** Transparent, plastic covers should be used on mockup units that contain parts whose operation may be checked visually, unless a metal cover is needed for electrical shielding. [Source: AFSC DH 1-3, 1980]
- **4.13.4.7 Easy access.** All mockup units shall be installed so that every unit is accessible without removing any other unit. [Source: AFSC DH 1-3, 1980]

4.13.5 Storage space

- **4.13.5.1 Available storage.** Storage space shall be provided for removable items, for example, test leads. [Source: AFSC DH 1-3, 1980]
- **4.13.5.2 Securing accessories.** Fasteners and holders shall be provided to hold accessories securely and safely in the storage compartment. [Source: AFSC DH 1-3, 1980]
- **4.13.5.3 Labeling.** A label shall show the intended contents of the storage compartment and how they should be stored. [Source: AFSC DH 1-3, 1980]
- **4.13.5.4 Handles.** If test equipment has hinged handles on the cover or case, the handles shall be recessed for convenient storage. [Source: AFSC DH 1-3, 1980]

4.14 Tools

Rules for common hand tools and special tools are given in this section. The tools required by maintainers depend upon the nature of the maintenance tasks and the characteristics of the equipment. It is highly desirable that the need for special tools, that is, tools other than the most common types and sizes of hand tools, be eliminated or at least minimized. This goal can best be accomplished early in the equipment design process, but it deserves attention throughout design and development. [Source: MIL-HDBK-759B, 1992]

4.14.1 General

- **4.14.1.1 Minimize maintenance tools.** Units of equipment shall be designed to minimize the numbers and types of auxiliary tools required to accomplish maintenance tasks. [Source: NASA-STD-3000A, 1989]
- **4.14.1.2 Use common tools.** Whenever possible, units of equipment shall be designed to use common tools for maintenance. [Source: AFSC DH 1-3, 1980; MIL-HDBK-759B, 1992]
- **4.14.1.3 Minimize variety and sizes of tools required.** The variety and number of different sizes of tools required shall be minimized; ideally, the tools required shall be limited to those normally found in a maintainer's tool kit. [Source: MIL-HDBK-759B, 1992]
- **4.14.1.4 Special tools.** Uncommon or specially-designed tools shall be used only when common hand tools do not satisfy the requirements or when the special tools provide a significant advantage over common hand tools. Special tools shall not be required or used without the approval of the acquisition program office. [Source: MIL-STD-1472F, 1999; MIL-STD-1800A, 1990]

4.14.2 Common hand tools

- **4.14.2.1 Use common test equipment and tools.** Systems and units of equipment shall be designed so that maintenance can be accomplished with common test equipment and tools. [Source: AFSC DH 1-3, 1980]
- **4.14.2.2 Gripping surfaces.** Tool handles shall have adequate gripping surfaces. [Source: MIL-HDBK-759B, 1992]
- **4.14.2.3 Providing thongs.** If a tool will be used where dropping it could cause injury, damage, or significant loss of time, the tool should be provided with a thong or other means of attachment to the maintainer or the equipment. [Source: MIL-HDBK-759B, 1992]
- **4.14.2.4 Insulation of handles.** If a tool will be used in the vicinity of voltages in excess of 30 volts, the tool handle and any other part of the tool the maintainer is likely to touch shall be electrically insulated. [Source: MIL-HDBK-759B, 1992]

4.14.3 Special tools

- **4.14.3.1 Reasons for requiring special tools.** Special tools shall be required only when common tools cannot be used or when they are necessary to facilitate maintenance tasks, reduce time, or improve accuracy. [Source: MIL-HDBK-759B, 1992]
- **4.14.3.2 Availability of special tools.** If a special tool is required for the maintenance of a unit of equipment, the tool shall be made available at the same time as the equipment. [Source: MIL-HDBK-759B, 1992]
- **4.14.3.3 Attach to equipment.** If a unit of equipment requires a special tool for maintenance, the tool should be mounted on or attached to the equipment in a readily accessible location. [Source: MIL-STD-1472F, 1999]

Glossary

Automatic test equipment - Checks two or more signals in sequence without the intervention of a maintainer. The test usually stops when the first out-of-tolerance signal is detected.

Built-in test equipment - An integral part of a unit of equipment and can range from a simple voltmeter to a complex automatic checker.

Cable - A number of lines bound together within a single, permanent sheath.

Case - The part of a unit of equipment that encloses and protects the equipment from its surroundings. It may also serve to protect the surroundings - including maintainers - from the equipment.

Collating test equipment - Presents the results of two or more checks as a single display; for example, a light might come on only if a number of different signals are in tolerance.

Component - A subdivision of a unit of equipment that can be treated as an object by the maintainer, but which can be further broken down into parts. A mounting board together with its mounted parts is an example of a component.

Connector - A piece of hardware that joins or attaches lines or cables to other lines or cables or to units of equipment. The term is used rather loosely to refer to either of the two parts that mate with each other and to the plug that mates with a receptacle.

Cover - A part of a unit of equipment that closes an access opening.

Fasteners - Devices that join, attach, and mount parts, components, cases, covers, and units of equipment. They include quick fastening and releasing devices, screws, bolts, latches, catches, rivets, retainer rings, and retainer chains.

Go, no-go test equipment - Provides one of two alternative answers to any question. For example, it tells whether a given signal is in or out of tolerance.

Guard - An enclosure or barrier intended to prevent inadvertent or unauthorized operation of a control.

Hazardous condition - The presence of energy or a substance which is likely to cause death or injury by reason of physical force, shock, radiation, explosion, flames, poison, corrosion, oxidation, irritation or other debilitation. Biological and chemical hazards can have debilitating effects through disease or interference with physiological functions.

Hazardous location - A space within a facility, room, or open environment where a hazardous condition exists or is accessible or exposed within the system or equipment located within the space.

Interlocks - Devices (for example, switches) connected with a cover, shield, or case that disable the associated internal hazard (usually electrical) when the cover, shield, or case is opened. OSHA regulations discuss lockout and tagout procedures to be used in the workplace during maintenance or operations to protect from electrical hazards.

Item - A nonspecific term used to denote any product, available or in design or development, including parts, components, modules, and units of equipment.

Label - Alphanumeric information that identifies or describes an object. Labels can be printed directly on or adjacent to the object, or they can be printed on a card or plate that is attached to the object or adjacent to the object.

Layout - The physical arrangement of the parts and components that make up a module or a unit of equipment.

Limit stops - Mechanisms that restrict a moving object or part by stopping it at predetermined (limit) positions.

Line - Any single length of pipe, wire, or tubing.

Lockout - Uses a mechanical means to disable a control or switch in its safe position (for example, electricity disconnected) and to prevent its activation without the use of undue force or tools.

Marking - Nonverbal information, such as colors or symbols, that identifies or describes an object. Marking can appear directly on or adjacent to the object, or it can be printed on a card or plate that is attached to the object or adjacent to the object.

Modularization - The separation of equipment into physically and functionally distinct units that can be easily removed and replaced.

Module - An assemblage of two or more interconnected parts or components that comprise a single, physical and functional entity. It is this singular functionality that defines a module.

Mounting - The positioning and attachment of parts, components, and modules.

Packaging - (of a unit of equipment) - The assembling, mounting, and enclosing of the items it includes.

Part - An object that cannot normally be broken down further without destroying its designated use. Fuses, resistors, and capacitors are examples of parts.

Service points - A means for lubricating, filling, draining, charging, and performing other service functions. They permit the routine performance of these services on all equipment and components requiring them.

Shield - An enclosure or barrier intended to protect components that are susceptible to damage or to protect maintainers from possible injury.

Tagouts - Tags that are attached to a control or place of hazard to identify the required control condition and hazard associated with an ongoing mode of operation or maintenance.

Test points - A means for conveniently and safely determining the operational status of equipment and for isolating malfunctions.

Unit of equipment - An assemblage of items that may include modules, components, and parts that are packaged together into a single hardware package. For example, a computer, its keyboard, and its visual display are all units of equipment, as are radio transmitters and receivers.

References

- Department of Defense. (1961). *Electronical and electronic reference designations* (MIL-STD-16). Philadelphia, PA: Navy Publishing and Printing Office.
- Department of Defense. (1990). *Human engineering performance requirements for systems* (MIL-STD-1800A). Philadelphia, PA: Navy Publishing and Printing Office.
- Department of Defense. (1990). *Identification coding and application of hookup and lead wire* (MIL-STD-681). Philadelphia, PA: Navy Publishing and Printing Office.
- Department of Defense. (1990). *Identification, marking, and color coding of electrical cable and cords*. (MIL-STD-686C). Philadelphia, PA: Navy Publishing and Printing Office. (Available from <http://astimage.daps.dla.mil/quicksearch/>)
- Department of Defense. (1992). *Human factors engineering design for army materiel* (MIL-HDBK-759B). Philadelphia, PA: Navy Publishing and Printing Office.
- Department of Defense. (1993). *Identification, marking of U.S. military property*. (MIL-STD-130H). Philadelphia, PA: Navy Publishing and Printing Office. (Available from <http://astimage.daps.dla.mil/quicksearch/>)
- Department of Defense. (1995). *General guidelines for electronic equipment* (MIL-HDBK-454). Philadelphia, PA: Navy Publishing and Printing Office.
- Department of Defense. (1995). *Marking of connections for electrical assemblies* (MIL-STD-195). Philadelphia, PA: Navy Publishing and Printing Office.
- Department of Defense. (1999). *Design criteria standard – human engineering* (MIL-STD-1472 F). Philadelphia, PA: Navy Publishing and Printing Office.
- Department of Energy. (1985). *Human factors design guidelines for maintainability of department of energy nuclear facilities* (UCRL-15673). Washington, DC: U.S. Department of Energy.
- Department of the Air Force. (1980). *Human factors engineering* (AFSC DH 1-3). Wright-Patterson AFB, OH: ASD/ENESS.
- National Aeronautics and Space Administration. (1989). *Man-systems integration standards* (NASA-STD-3000A). Houston, TX: National Aeronautics and Space Administration.
- Snook, S.H., Ciriello, V.M. (1991). The design of manual handling tasks: revised tables of maximum acceptable weights and forces. *Ergonomics*, 34 (9): 1197 –1213.
- Title 29. *Occupational Health and Safety Standards* (OSHA 29 C.F.R.). Rehabilitation Act of 1973, 29 U.S.C. § 794 et seq. (amended 1974). Part 1910. Occupational Health and Safety Standards (29 CFR 1910): Washington, DC.

Index

	minimizing need for maintenance.....	4-5
A		
Adjustment controls		4-90
C		
Circuit breakers		4-92
labeling and marking		4-98
legend switch		4-96
push-pull		4-94
toggle bat.....		4-96
Connectors		
alignment aids		4-54
electrical connections.....		4-55
gaskets and seals		4-73
labeling, marking, and coding.....		4-58
location and accessibility		4-53
types		4-52
Covers, guards, and shields		
hinged covers		4-37
interlocks.....		4-38
labeling and marking.....		4-39
shape		4-37
size		4-36
sliding doors and caps.....		4-37
Cranes		4-15
D		
Designing equipment for handling		
alignment aids		4-14
designing for remote handling		4-14
grasp areas.....		4-13
handles		4-8
shape		4-8
size		4-8
stands and rests		4-13
weight.....		4-6
Designing equipment for maintenance		
connectors		4-51
covers, guards, and shields.....		4-33
designing equipment for handling		4-5
fasteners		4-40
lines and cables		4-59
E		
Electrical		
bench mockup cables		4-68
clamps and mounting plates.....		4-65
labeling, marking, and coding.....		4-69
leads		4-65
length of cables and leads		4-61
routing and mounting.....		4-63
test and extension cables.....		4-67
Electrical connections		
plugs and receptacles		4-55
wire connections		4-56
Equipment		
arrangement.....		4-15
mounting		4-15
packaging.....		4-15
F		
Fasteners		
labeling, marking, and coding.....		4-50
number		4-43
types		4-43
Fluid and gas lines		
clamps and supports.....		4-73
labeling, marking, and coding.....		4-75
routing and mounting.....		4-72
Fuses		4-92, 4-93
labeling and marking.....		4-98
H		
Handles		
dimensions		4-10
handle characteristics		4-9
location.....		4-12
when handles are needed		4-8
Hazardous conditions.....		4-4
Hazardous location.....		4-4
Hoists		4-15

quick fastening and releasing devices 4-49
quick-action..... 4-53
screw and bolt heads 4-45

screws..... 4-44
threaded..... 4-52