

# SMDS User Application Trials

James D. McCabe

NAS Systems Development

`jmccabe@nas.nasa.gov`

---

This paper discusses the trial of scientific user applications over the Switched Multimegabit Data Service (SMDS). An interLATA (Local Access Transport Area) testbed was built between NAS<sup>1</sup> and Rockwell International, using AT&T, GTE, and PacBell SMDS. The interactive and throughput characteristics of SMDS were tested using interactive and file transfer applications, and scientific user applications that visualized Computational Fluid Dynamics (CFD) solution data. Results from these tests showed that, for scientific user applications, SMDS performed as well as point-to-point data circuits. By increasing available capacity to the users, new visualization methods were enabled.

## *Introduction*

---

This paper discusses the trial of scientific user applications over the Switched Multimegabit Data Service (SMDS), a high-performance, connectionless, public packet switching service intended to provide data communications services over the metropolitan or long-haul network environments.

A testbed was built to test SMDS from an operational viewpoint. Participants in the testbed were AT&T, GTE, NAS, PacBell, and Rockwell

---

1. Numerical Aerodynamic Simulation Program, NASA/Ames Research Center.

International. This was the first trial of SMDS as an InterLATA service, and consisted of operating the network in both production and testbed modes. The participants, which included both service providers and users, developed a test plan that had three goals:

1. Testing interoperability of SMDS with existing protocols and media.
2. Testing interoperability between multiple vendor implementations of SMDS.
3. Conducting trials of scientific user applications over SMDS.

This report focuses on the scientific user application trials.

## Purpose

For the application trials, the following objectives were developed:

- Determine if, for interactive applications, there were any perceptible differences in response times between SMDS and point-to-point data circuits.
- Evaluate SMDS in comparison with existing AEROnet<sup>2</sup> parallel point-to-point data circuits. Compare:
  - Throughput
  - Effectiveness of user applications

Since the AEROnet circuits were of lower capacity than the SMDS test circuit (112 Kb/s vs. 512 Kb/s), throughput comparisons were based on percentage of circuit capacity.

## Method

---

For the scientific applications trials, the SMDS testbed was in production mode between the NAS facility at Ames Research Center and the Rockwell International Downey facility (Figure 1). Capacity of the SMDS InterLATA service was at the T3 (45 Mb/s) rate, which was reduced to the local loop rate of T1 (1.544 Mb/s) at NAS and Rockwell, and the Rockwell T1 was further reduced to 512 Kb/s at the Rockwell link to the Downey facility. Thus, overall service capacity for the application trials was at 512 Kb/s.

---

2. AEROnet is the NASA National Aeronautics Network, centered at NAS.

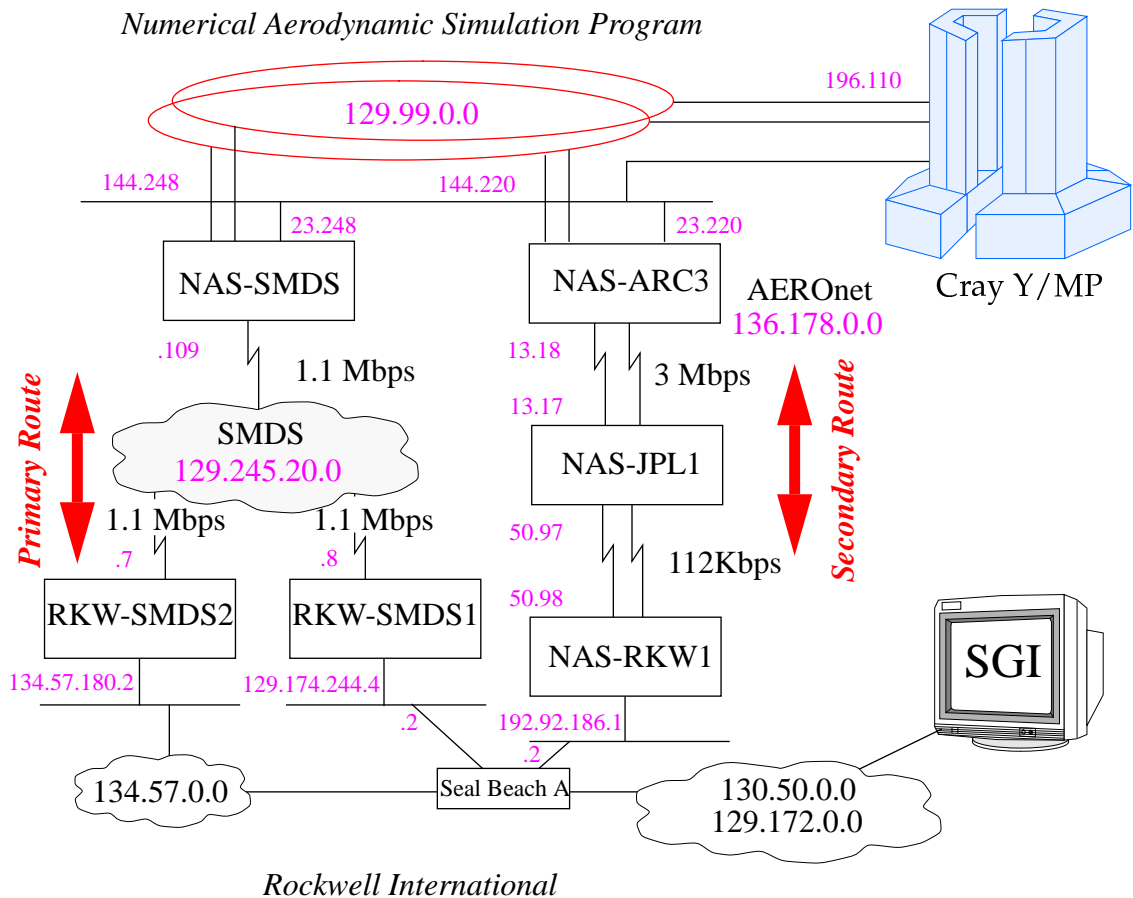

FIGURE 1. SMDS Testbed

For the production trial, AEROnet data circuits at a capacity of 112 Kb/s were in place and operating as a backup to SMDS. As shown in Figure 1, these circuits operated in parallel to SMDS. User application trials were also conducted over these circuits, in order to make comparisons between SMDS and point-to-point service.

Tests were run between the Cray Y-MP at the NAS facility and a Silicon Graphics workstation at the Rockwell Downey facility. These tests consisted of:

- Generic interactive applications (*Ping, Telnet*).
- File Transfers.

- Visualization of Computational Fluid Dynamics (CFD) solution data via the application *PLOT3D*<sup>2</sup>. For this application, the solution data was transferred across the SMDS network to the local workstation, where the visualization process was applied.
- Visualization of CFD data via *distributed PLOT3D*. In this application, the visualization process is distributed between the supercomputer (Cray Y-MP) and the user's workstation. The supercomputer generates the geometry information for the solution and passes that data (as polygons) to the workstation, which in turn renders and displays the data.

CFD solution data were used from three projects:

1. 3D Separated Steady/Unsteady Exhaust Flows, Principal Investigator - Sukumar Chakravarthy (Rockwell International Science Center)
2. CFD Simulation of Multiple Body Dynamics, Principal Investigator - Kurian Mani (Rockwell International)
3. Navier-Stokes Predictions of Hypersonic, Chemically Reacting Flows, Principal Investigator - John Wang (Rockwell International, North American Aircraft Division)

For the PLOT3D and distributed PLOT3D applications, visualizations of two-dimensional particle traces, three-dimensional particle traces, and contour plots were attempted.

For comparison, each of the application tests were run over both the 512 Kb/s SMDS service and the 112 Kb/s AEROnet service.

## *Results*

---

From the set of generic interactive tests, no perceptible differences between SMDS and point-to-point data circuits were found. The round-trip delays from tests of ICMP echo (ping) were similar for both SMDS and AEROnet, 30-31 ms for a 64 byte packet. Telnet behavior was equivalent for both networks.

Results from the file transfer trials are summarized below (PP = Point-to-Point data circuit at 112 Kb/s, SMDS = SMDS at 512 Kb/s):

**TABLE 1.** File Transfer Trial Results

Network Type	File Size (M Bytes)	Source	Destination	Time (Sec)	Transfer Rate (% Cap)
PP	8.8	Cray	SGI	796	78.6
PP	8.8	SGI	Cray	858	73.2
SMDS	8.8	Cray	SGI	191	71.9
SMDS	8.8	SGI	Cray	205	67.2
PP	4.5	Cray	SGI	414	76.8
PP	4.5	SGI	Cray	429	74.1
SMDS	4.5	Cray	SGI	101	69.7
SMDS	4.5	SGI	Cray	108	64.4
PP	2.7	Cray	SGI	242	78.6
PP	2.7	SGI	Cray	247	77.7
SMDS	2.7	Cray	SGI	61	68.6
SMDS	2.7	SGI	Cray	64	65.2

The files used in the file transfer tests were CFD solution files from the three CFD visualization projects listed in section 2.0.

Results for the CFD visualization tests were subjective, as they reflect the scientists' perceptions of the viability of the application over the network service. The results were broken down into: *successful*, when the scientists were able to use the application to their satisfaction; *not successful*, when the scientists described the application as "not usable" over the network service, and *successful, but slow*, when the application worked but the response time was sufficiently long as to make the application difficult to use.

PLOT3D (local to workstation)

Two-Dimensional Particle Rakes:

- 112 Kb/s Point-to-Point data circuit (PP) - successful
- 512 Kb/s SMDS (SMDS) - successful

Three-Dimensional Particle Rakes:

- PP - not successful
- SMDS - not successful

Contour Plots:

- PP - not successful
- SMDS - successful, but slow

Distributed PLOT3D

Two-Dimensional Particle Rakes:

- PP - successful
- SMDS - successful

Three-Dimensional Particle Rakes:

- PP - not successful
- SMDS - successful

Contour Plots:

- PP - not successful
- SMDS - successful

Visualizations generated from distributed PLOT3D are shown in Appendix A.

## *Discussion*

---

The characteristics of SMDS that were tested in this trial were: response time for interactive applications, network throughput (in comparison with point-to-point data circuits), and the usefulness of the service for visualizing CFD solutions. From a users' perspective, there was no difference in the response time characteristics between SMDS and point-to-point data circuits. In particular, the application *telnet* worked equally well with both networks.

The improvement in throughput for file transfers using SMDS was roughly equivalent to the increase in capacity of that network over the point-to-point network, AEROnet. Throughput increased with increasing file size, and was always greater for transfers from the supercom-

puter to the workstation. This is consistent with previous tests of file transfer applications over networks. Throughput increases when the transfer reaches steady-state, after the initial start-up period when algorithms such as slow-start are predominant. In terms of percentage of circuit capacity, SMDS operated between 71.9% and 64.4%, while the point-to-point data circuit operated between 78.6% and 73.2%. SMDS overhead accounts for the difference in percent capacity. For file transfers under equivalent conditions, throughput over SMDS varied from 6.7% to 12.5% less than that for the point-to-point data circuit.

For the visualization applications, use of SMDS at 512 Kb/s made a difference in their usability. Two-dimensional particle traces required the least amount of data transfer and compute cycles, and were successfully done in every attempt. Three-dimensional particle traces require more compute and network resources, and were only successful when done with distributed PLOT3D over SMDS. Distributed PLOT3D was necessary in order to offload the post-processing of the solution file to the supercomputer. The 512 Kb/s capacity of SMDS was necessary to support the data transfer requirement of the distributed application. The behavior of PLOT3D in producing contour plots was similar to that for three-dimensional particle traces. In this case, the 512Kb/s capacity of SMDS enabled the use of contour plots with local PLOT3D, although the interactive performance of the application was poor.

Three-dimensional particle traces and contour plots could be generated only via the Distributed PLOT3D application over the 512 Kb/s SMDS, and this trial was the first time that such visualization techniques were used by scientists at Rockwell accessing CFD solution data at NAS via AEROnet.

It is important to note that it was the increase in capacity of the network, and not SMDS itself, that enabled the new visualization techniques to be used.

## *Conclusion*

---

This paper discussed the trial of scientific user applications over SMDS. From evaluating the interactive and performance characteristics of SMDS, the following may be stated about SMDS for this trial:

- The interactive characteristics of SMDS are similar to those for a point-to-point data circuit. In particular, the interactive behavior of scientific user applications over SMDS was equivalent to that for point-to-point data circuits.
- Transfer rates are slightly less over SMDS than for a point-to-point data circuit. Some factors that may impact the throughput results must be taken into account:
  - The tests were run in production mode, which meant that other traffic was using SMDS at the same time.
  - The capacities of the two networks over which the tests were run were not equivalent.
- By increasing the capacity of the network, the use of SMDS enabled the scientist to visualize CFD data by methods that would not function with lower capacity networks. Although it is the increase in capacity, and not SMDS itself, that enabled new visualization methods to occur, if SMDS can, by being more cost effective, provide greater capacity to the users, then this service can become an enabling technology.

For future work, it would be interesting to increase the capacity of SMDS to T3 (45 Mb/s) rate and evaluate the performance of scientific applications at the various SMDS Access Classes of 4, 10, 16, 25, and 34 Mb/s.

## *References*

---

1. Walatka, P.P., Buning, P.G., Pierce, L., and Elson, P.A., PLOT3D User's Guide, NASA Technical Memorandum 101067, March 1990.

## *Appendix A - CFD Visualization Results*

---

The first picture shows a contour plot of two three-dimensional combustor flows with transverse jets. Two sonic, normal air jets are located behind a backward-facing step, and inject air into a Mach 2 flow stream. Shock waves can be seen emerging from both jet inlets. This picture is from the project *Navier-Stokes Predictions of Hypersonic, Chemically Reacting Flows*, John Wang PI.

The second picture represents a three-dimensional particle trace of hydrogen injection normal to a Mach 2 airflow, and is part of a model



*for Fuel/Air Turbulent Combustion in a Three-Dimensional Scramjet Com-  
bustor, Sukumar Chakravarthy PI.*