

**Final Remedial Action Report
for Operable Unit 4 –
Silos 1 through 4**

TABLE OF CONTENTS	
1.0 Introduction	1
2.0 Operable Unit 4 Background	8
3.0 Construction Activities	14
4.0 Chronology of Events	18
5.0 Performance Standards and Construction Quality Control	20
6.0 Final Inspections and Certifications	22
7.0 Operation and Maintenance Activities	23
8.0 Summary of Project Costs	24
9.0 Observations and Lessons Learned	25
10.0 Operable Unit Contact Information	26
Appendix A – Cost and Performance Summary	27
Appendix B – Schematic of Treatment Systems	30
Appendix C – HWMU Closures	34
Appendix D – Removal Actions	35
Appendix E – Legal Agreements	37
Appendix F – References	39
Appendix G – Waste Unit Photos	41
Appendix H – List of Acronyms	44
Appendix I – Signature Page	46

4000-RP-0038

1.0 INTRODUCTION

This document serves as the Comprehensive Environmental Response, Compensation, and Liability Act (CERCLA) Final Remedial Action Report for Operable Unit 4 at the U.S. Department of Energy’s (DOE’s) Fernald Closure Project (FCP) located near Cincinnati, Ohio. It has been prepared to meet U.S Environmental Protection Agency (EPA) guidance for CERCLA site closeout as described in EPA Office of Solid Waste and Emergency Response (OSWER) Directive No. 9320.2-09A-P, *Closeout Procedures for National Priorities List Sites* (January 2000). As stated in this directive, the aim of the guidance is to communicate EPA’s key principles and expectations for remedial action closeout along with “best practices” based on CERCLA program experience that should be consulted for closing out National Priorities List (NPL) sites in a consistent and reasonable manner across the program. The guidance recommends a standard closeout report outline that has been followed in the preparation of the Operable Unit 4 Final Remedial Action Report.

During the fall of 2004, EPA and DOE identified the manner in which the time-sequenced individual closeout reports would be coordinated across the five operable units at the FCP. This approach recognizes that with the exception of final disposal of Silos 1 and 2 material, the source-control remedial actions (i.e., Operable Units 1, 2, and 4), decontamination and dismantlement (D&D) and legacy waste disposition activities (Operable Unit 3), the majority of soils remediation (part of Operable Unit 5), and the closure of the FCP’s on-site disposal facility (OSDF) are all targeted for completion in 2006. The remaining activities that extend beyond 2006 are: 1) final offsite disposal of Silos 1 and 2 material; 2) continued restoration activities for the Great Miami Aquifer; 3) the performance monitoring and final certification activities necessary to demonstrate completion of aquifer restoration; and 4) the final D&D and removal, as required, of groundwater related facilities and any

affected soils above final remediation levels beneath the groundwater facilities. As the mechanism to communicate the agreed-to closeout report strategy, EPA and DOE issued a fact sheet in the spring of 2005 [DOE 2005a] describing the coordination approach across the operable units as described in detail in Section 1.4. This Final Remedial Action Report for Operable Unit 4 has been prepared in accordance with that strategy.

Operable Unit 4 is one of the five operable units identified in the amended consent agreement (ACA) and consists of Silos 1, 2, and 3 and their contents, the empty Silo 4, and associated facilities. In accordance with agreements reached between DOE and EPA to communicate the overall remedial action closeout report strategy across the operable units, the closeout report for Operable Unit 4 is designed to document the completion of offsite shipment and temporary storage of the contents of Silos 1 and 2 and the off-site disposal of the contents of Silo 3. The remaining operable unit scope (soil remediation within the Operable Unit 4 boundary, and D&D of Operable Unit 4 remediation facilities and the empty silo structures) would be documented in the closeout reports for



Operable Units 5 and 3, respectively. A final remedial action report will be prepared for Operable Unit 4 once final disposal of the Silo 1 and 2 contents has been achieved.

This closeout report is organized into ten major sections and nine appendices. Section 1.0 provides an overview of the FCP and the overall remedial activities comprising the FCP's sitewide cleanup program. Section 2.0 provides an overview specific to Operable Unit 4 and the remedial actions that were selected in the Operable Unit 4 Record of Decision (ROD) and its subsequent modifications. Section 3.0 addresses construction activities associated with the Operable Unit 4 remedial actions, and Section 4.0 provides an annotated chronology of the key events contributing to successful completion and documentation of the Operable Unit 4 remedial actions. Sections 5.0 and 6.0 address performance standards, quality control, and final inspections and certifications, while Section 7.0 summarizes operations and maintenance information, as appropriate. Section 8.0 summarizes remedy cost information, and compares actual remedial costs with the original estimates contained in the Operable Unit 4 ROD. Section 9.0 identifies lessons learned during remedy implementation, and Section 10.0 summarizes key contact information.

1.1 Fernald Closure Project Overview

The FCP is a 1050-acre government-owned contractor-operated facility located in southwestern Ohio approximately 18 miles northwest of downtown Cincinnati. The facility is located just north of Fernald, Ohio, a small farming community, and lies on the boundary between Hamilton and Butler counties. Of the total size area, approximately 852 acres are in Crosby Township in Hamilton County and 200 acres are in Ross and Morgan Townships in Butler County.

The Atomic Energy Commission (AEC), predecessor to the U.S. Energy Research and Development Administration and then the U.S. DOE, established the Feed Materials Production Center (FMPC) in conformance with AEC orders in the early 1950s. In 1951, National Lead Company of Ohio, Inc., (NLO) entered into a contract with the AEC as the Management and Operations Contractor for the facility. This contractual relationship lasted until January 1, 1986. Westinghouse Materials Company of Ohio (WMCO), a wholly owned subsidiary of Westinghouse Electric Corporation, then assumed management responsibilities for the site operations and facilities. In 1991, Westinghouse renamed this subsidiary the Westinghouse Environmental Management Company of Ohio (WEMCO). During that same year, DOE renamed the site the Fernald Environmental Management Project (FEMP) to reflect the site's revised mission. On December 1, 1992, Fernald Environmental Restoration Management Company (FERMCO) (now Fluor Fernald) assumed responsibility for the site as the Environmental Restoration Management Contractor for DOE. The FEMP was renamed the Fernald Closure Project on January 27, 2003.

1.2 Mission of the Site

The primary mission of the FMPC during its 37 years of operation was the processing of feed materials to produce high purity uranium metal. These high purity uranium metals were then shipped to other DOE or U.S. Department of Defense facilities for use in the nation's weapons program. Manufacture of the uranium metal products generally occurred in 7 of the more than 50 production, storage, and support buildings that comprised what was known as the production area. During the 37 years of production operations, nearly 500 million pounds of uranium metal products were produced. The site also served as the nation's key federal repository for thorium related nuclear products, and it also recycled uranium used in the reactors at the Hanford site.

In accomplishing the site mission, liquid and solid wastes were generated by the various operations between 1952 and 1989. Before 1984, solid and slurried wastes from production processes were deposited in the on-property waste storage area. This area, located west of the former production area, includes: six low-level radioactive waste storage pits; two earthen-bermed concrete silos (Silos 1 and 2) containing K-65 residues; one concrete silo containing metal oxides (Silo 3); one unused concrete silo (Silo 4); two Lime Sludge Ponds; a burn pit; a clearwell; and a Solid Waste Landfill. After 1984, wastes produced from operations were containerized for eventual shipment to off site disposal facilities. Contaminants from material processing and related activities were released into the environment through air emissions, wastewater discharges, storm water runoff, and leaks and spills.

1.3 Regulatory History

The CERCLA Remedial Investigation/Feasibility Study (RI/FS) process at the FEMP began in 1986, in accordance with a Federal Facility Compliance Agreement (FFCA) between DOE and EPA to cover environmental impacts associated with the FMPC. The FFCA was intended to ensure that environmental impacts associated with activities at the facility would be thoroughly and adequately addressed. In response to the FFCA, a site-wide RI/FS was initiated pursuant to CERCLA, as amended by the Superfund Amendment and Reauthorization Act (SARA). Production operations at the facility were suspended in 1989 and the facility was placed on the NPL. The FFCA was amended in April 1990 by a Consent Agreement (under §120 and 106[a] of CERCLA) that revised the milestone dates for the RI/FS and provided for implementation of removal actions. The Consent Agreement was amended in September 1991 to revise schedules for completing the RI/FS process. This ACA provided for implementation of the operable unit concept. The FEMP was partitioned into five operable units to promote a more structured and expeditious cleanup. The schedule for preparation of a remedial investigation report and feasibility study report for each operable unit, including Operable Unit 4, was included in the ACA.

The Ohio Environmental Protection Agency's (Ohio EPA) Office of Federal Facilities Oversight (OFFO) also oversees cleanup activities at the site as a support agency primarily through the December 1988 Consent Decree and its subsequent amendment in January 1993. Ohio EPA conducts environmental monitoring, public outreach, restoration and remediation oversight at the FCP, as well as maintains authority for Resource Conservation and Recovery Act (RCRA) enforcement. The June 1996 Director's Final Findings and Orders (DF&O) between the DOE/Fluor Fernald and the Ohio EPA provide orders for closure activities relative to several Hazardous Waste Management Units (HWMUs) established at the site to satisfy both RCRA and CERCLA requirements.

1.4 Sitewide Operable Units and Cleanup Strategy

For purposes of investigation and study, the remedial issues and concerns that were similar in location, history, type/level of contamination, and inherent characteristics were grouped into operable units under the 1991 ACA. Specifically, the site was divided into five operable units. Four of the operable units (1 through 4) are considered "source" operable units as they represent the sources of contamination that have affected the site's environmental media. The fifth operable unit (Operable Unit 5) is considered the "environmental media" operable unit as it represents the environmental media affected by past production operations and waste disposal practices (i.e., beyond the "source" operable unit boundaries), as well as the pathways of contaminant migration at the site. The four "source" operable units and the fifth environmental media operable unit are described below:

- Operable Unit 1: Waste Pit Area. Waste Pits 1 through 6, Clearwell, Burn Pit, berms, liners, and soil within the operable unit boundary.
- Operable Unit 2: Other Waste Units. Fly Ash Piles, other South Field disposal areas, Lime sludge Ponds, Solid Waste Landfill, berms, liners, and soil within the operable unit boundary.

- Operable Unit 3: Former Production Area. Former production and production-associated facilities and equipment (including all above- and below-grade improvements), including, but not limited to, all structures, equipment, utilities, drums, tanks, solid waste, waste, product, thorium, effluent lines, a portion of the K-65 transfer line, wastewater treatment facilities, fire training facilities, scrap metal piles, feedstocks, and coal pile. Note that all affected soil beneath the facilities resides within Operable Unit 5.
- Operable Unit 4: Silos 1 through 4. Contents of Silos 1, 2, 3 (Silo 4 remained empty); the silos structures, berms, decant sump tank system, and soil within the operable unit boundary.
- Operable Unit 5: Environmental Media. Groundwater, surface water, soil not included in the definitions of Operable Units 1 through 4, sediment, flora and fauna.

During the time period 1994 to 1996, DOE and EPA signed the final RODs for each operable unit, in cooperation with the Ohio EPA and the Fernald Citizen's Advisory Board, which set in motion the major cleanup requirements and approaches that collectively define the FCP cleanup. The RODs employ a combination of off-site and on-site disposal, under which approximately 77 percent of the remedial waste volume (the site's lower concentration, higher volume materials) are to be disposed of in the OSDF while approximately 23 percent (the site's higher concentration, lower volume materials) are to be sent off site for disposal, primarily at permitted facilities in Utah, Nevada, and Texas.

At the time the RI/FS activities were completed and the RODs put in place, 31 million pounds of uranium products, 2.5 billion pounds of waste, 255 buildings and structures, and 2.75 million cubic yards of contaminated soil and debris were identified as requiring action. In addition, a 223-acre portion of the Great Miami Aquifer was found to be contaminated at levels above radiological drinking water standards. Under the sitewide approach, the final remedial actions contained in the operable unit RODs are:

- Production and support facility D&D.
- On-site disposal of contaminated soil, above-and below-grade debris, and Operable Unit 2 other waste unit materials, provided OSDF waste acceptance criteria (WAC) are met.
- Off-site disposal of the contents of the silos, the waste pit materials, nuclear product inventories, containerized low-level and mixed waste inventories, and the quantities of soil and debris that do not meet OSDF WAC.
- Extraction and treatment of contaminated groundwater to restore the contaminated portions of the Great Miami Aquifer to meet Safe Drinking Water Act requirements.

At completion, approximately 975 acres of the 1,050-acre property will be restored for use as an undeveloped park, the target land use selected in the Operable Unit 5 ROD and approximately 75 acres will be dedicated to the footprint of the OSDF. The Great Miami Aquifer will be restored to drinking water standards, and long-term stewardship actions and requisite institutional controls will be put in place consistent with the target land use.

Taken together, the individual RODs for the operable units provide a site-wide cleanup approach that encompasses all contaminant source areas and all affected environmental media at the site. Collectively the RODs provide a natural link between the remediation of the sources of contamination and the media affected. Each ROD progressively built on the decisions of the earlier RODs, yielding a cohesive and comprehensive remedy for the FCP. The dates of ROD signature and progressive sequence of decisions adopted under the RODs are shown below:

- Operable Unit 3 ROD for Interim Remedial Action (July 22, 1994) – Provided accelerated approval for the D&D of the FCP's buildings and structures.

- Operable Unit 4 ROD for Final Remedial Action (December 7, 1994) – Provided for the remediation of Silos 1 through 4, affected soil within the operable unit boundary, and other sources of contamination with the boundary. The D&D of all remedial facilities constructed for the Operable Unit 4 remedial action are to be addressed as part of Operable Unit 3.
- Operable Unit 1 ROD for Final Remedial Action (March 1, 1995) – Provided for the remediation of the waste pit contents, caps, liners, affected soil within the operable unit boundary, and other sources of contamination within the boundary. The D&D of all remedial facilities constructed for the Operable Unit 1 remedial action are to be addressed as part of Operable Unit 3.
- Operable Unit 2 ROD for Final Remedial Action (June 8, 1995) – Provided for the remediation of the Active and Inactive Flyash Piles, South Field disposal area, Lime Sludge Ponds, Solid Waste Landfill, affected soil within the operable unit boundary, and other sources of contamination with the boundary. This decision set in motion the approval of onsite disposal at the FCP and the construction of the OSDF; however, at the time it was formally limited to the disposal of the Operable Unit 2 wastes since the Operable Units 5 and 3 decisions related to waste disposition (on site or off site) were not yet final.
- Operable Unit 5 ROD for Final Remedial Action (January 31, 1996) – Provided for the remediation of the FCP’s on-site and off-site environmental media. This ROD addressed the cleanup of the Great Miami Aquifer at all locations, and the remediation of affected site-wide soils outside the source operable unit boundaries. It also addressed the monitoring of air, surface water, groundwater, sediment, and biota. The Operable Unit 5 ROD finalized the concept of a site-wide OSDF, and further incorporated the “balanced approach” concept into FCP on-site and off-site waste disposition decisions. The D&D of all remedial facilities constructed to support the Operable Unit 5 groundwater remedial action were to be addressed as part of Operable Unit 3.
- Operable Unit 3 ROD for Final Remedial Action (September 24, 1996) – Provided a final disposition decision for the D&D materials generated through the Interim Remedial Action ROD. Consistent with the Operable Unit 5 decision, this final decision document adopted on-site disposal as the selected remedy for disposition of the D&D debris. It also adopted earlier decisions as part of the “balanced approach” to send the FCP’s containerized waste inventories and nuclear materials off site. The ROD also acknowledged that the D&D of new remedial facilities constructed at the site would be addressed as part of Operable Unit 3.

1.5 Remedial Action Closeout Report Strategy -- Spring 2005 Fact Sheet

In the spring of 2005, DOE and EPA developed a Fact Sheet to describe the strategy for producing the closeout reports for the CERCLA operable unit remedial actions completed for the FCP. Where affected media (primarily soils within an operable unit boundary) was a part of the source operable unit remedy, it was determined to be appropriate to accommodate the documentation of the remediation of those soils under the Operable Unit 5 closeout report. Therefore, only the source waste material would be addressed in the respective source operable unit closeout reports, while the contaminated media within the source operable unit boundaries would be addressed under Operable Unit 5. In essence, this fact sheet adopted the following strategy for submitting remedial action closeout reports for EPA approval, summarized in Figure 1-1:

- Proceed with formal closeout of Operable Unit 1 when the waste pit contents and liners have been successfully dispositioned off site. The remaining operable unit scope (soil remediation within the Operable Unit 1 boundary and D&D of Operable Unit 1 remediation facilities) would be documented in the closeout reports for Operable Units 5 and 3, respectively. Soil remediation underlying the waste pits would be completed and documented in the Soil Remediation Area 6 Certification Report.

- Proceed with formal closeout of Operable Unit 2 when the waste materials from the Solid Waste Landfill, Lime Sludge Ponds, Fly Ash Piles, and the South Field Area have been successfully placed in the OSDF, or dispositioned off site as necessary based on OSDF WAC restrictions. The remaining operable unit scope (soil remediation within the Operable Unit 2 waste unit boundaries) would be documented in the closeout report for Operable Unit 5. Remediation of the soil underlying the Solid Waste Landfill and Lime Sludge Ponds would be completed and documented in the Soil Remediation Areas 6A and 6I Certification Reports respectively. The remediation of soil underlying the Active and Inactive Flyash Piles and the South Field Area have already been completed and certified as a part of Soil Remediation Area 2 Phase 1 (Southern Waste Units).
- Proceed with formal closeout of Operable Unit 3 when the D&D of sitewide facilities – including the remediation facilities constructed for Operable Units 1 and 4 – are complete and all legacy-era containerized wastes have been successfully dispositioned.
- Proceed with a final remedial action report for Operable Unit 4 when the silo contents from Silos 1 and 2 and Silo 3 have been successfully transported off site. The final report will address completion of retrieval, packaging, and removal of the Silo contents from the site, but will also recognize that final permanent disposal of the Silo 1 and 2 material will remain as an open item to be closed out with a future addendum to this final remedial action report when disposal has been completed in accordance with the 2005 Explanation of Significant Differences (ESD)[DOE 2005b] for Operable Unit 4. The remaining operable unit scope (soil remediation within the Operable Unit 4 boundary and D&D of Operable Unit 4 remediation facilities and the empty silo structures) would be documented in the closeout reports for Operable Units 5 and 3, respectively. Remediation of the soil underlying the Operable Unit 4 boundary will be completed and documented under Soil Remediation Area 7.
- Proceed with interim remedial action reports for Operable Unit 5 that recognizes that Great Miami Aquifer restoration activities will continue beyond DOE’s 2006 baseline closure date. As interim reports, the reports will address completion of soil restoration activities (including those within the Operable Units 1, 2, and 4 boundaries) and closure of the OSDF, but will also need to recognize that ongoing aquifer restoration activities, future D&D of groundwater infrastructure, and final soil remediation (as necessary beneath the remaining groundwater infrastructure) remain as open items that will be closed out with a future final remedial action report for Operable Unit 5 once groundwater actions are complete. The interim remedial action reports under Operable Unit 5 will consist of three independent sections: soil and sediment remediation, OSDF closeout, and aquifer restoration activities.

Figure 1-1 Summary of CERCLA Remedial Action Closeout Reports and Schedule

Operable Unit	Key Closeout Activity	Where Documented	Remaining Scope	Where Documented
Operable Unit 1 Waste Pits	Waste pit contents successfully dispositioned off site	Final Remedial Action Report for Operable Unit 1 (Summer 2006)	Soil Remediation within Operable Unit 1 boundary	Interim Remedial Action Report for Operable Unit 5 (Fall 2006)
			D&D of Operable Unit 1 Remediation Facilities	Final Remedial Action Report for Operable Unit 3 (Fall 2006)
Operable Unit 2 Other Waste Units	Wastes from Solid Waste Landfill, Lime Sludge Ponds, Fly Ash Piles, and Southfield successfully placed in OSDF or dispositioned off site as required	Final Remedial Action Report for Operable Unit 2 (Fall 2006)	Soil Remediation within Operable Unit 2	Interim Remedial Action Report for Operable Unit 5 (Fall 2006)
Operable Unit 3 Production Area Facilities	D&D of site-wide facilities (except for groundwater infrastructure); completion of Legacy Waste disposal	Final Remedial Action Report for Operable Unit 3 (Fall 2006)	None	NA
Operable Unit 4 Silos	Silo 3 material successfully disposed off site; Silos 1 and 2 material successfully treated, packaged and transported offsite	Final Remedial Action Report for Operable Unit 4 (Fall 2006)	Soil Remediation within Operable Unit 4 boundary	Interim Remedial Action Report for Operable Unit 5 (Fall 2006)
			D&D of Operable Unit 4 Remediation Facilities	Final Remedial Action Report for Operable Unit 3 (Fall 2006)
			Permanent offsite disposal of Silos 1 and 2 material	Addendum to the Final Remedial Action Report for Operable Unit 4 (post-closure)
Operable Unit 5 Environmental Media	Groundwater remediation infrastructure is installed and operating.	Interim Remedial Action Report for Operable Unit 5 (Fall 2006)	D&D of groundwater facilities once groundwater remedy is complete; certification of surface water and sediments	Final Remedial Action Report for Operable Unit 5 (post-closure)
	Completion of all soil remediation site wide, except for beneath long-term groundwater facilities	Interim Remedial Action Report for Operable Unit 5 (Fall 2006)	Soil remediation and certification beneath groundwater facilities	Final Remedial Action Report for Operable Unit 5 (post-closure)
	The On-Site Disposal Facility is capped	Interim Remedial Action Report for Operable Unit 5 (Fall 2006)	Long-term care and monitoring	Final Remedial Action Report for Operable Unit 5 (post-closure)

2.0 OPERABLE UNIT 4 BACKGROUND

Operable Unit 4 is located on the western area of the FCP property. Operable Unit 4 was defined in terms of three subunits. Subunit A consisted of Silos 1 and 2 containing K-65 residues, bentonite clay caps and the decant sump tank. Subunit B was comprised of Silo 3 containing the cold metal oxides. Subunit C included the four silo structures themselves (Silo 4 was empty and never used), the earthen berms around Silos 1 and 2, the old radon treatment system, and miscellaneous concrete structures such as pipe trenches.

Figure 2-1 shows the general location of the Operable Unit 4 area, relative to the remainder of the Fernald site and the ongoing cleanup operations underway for the other operable units. At the time of the photograph, construction of the Operable Unit 4 remediation facilities was underway.

Figure 2-1 Location of Operable Unit 4 (circa 2002)

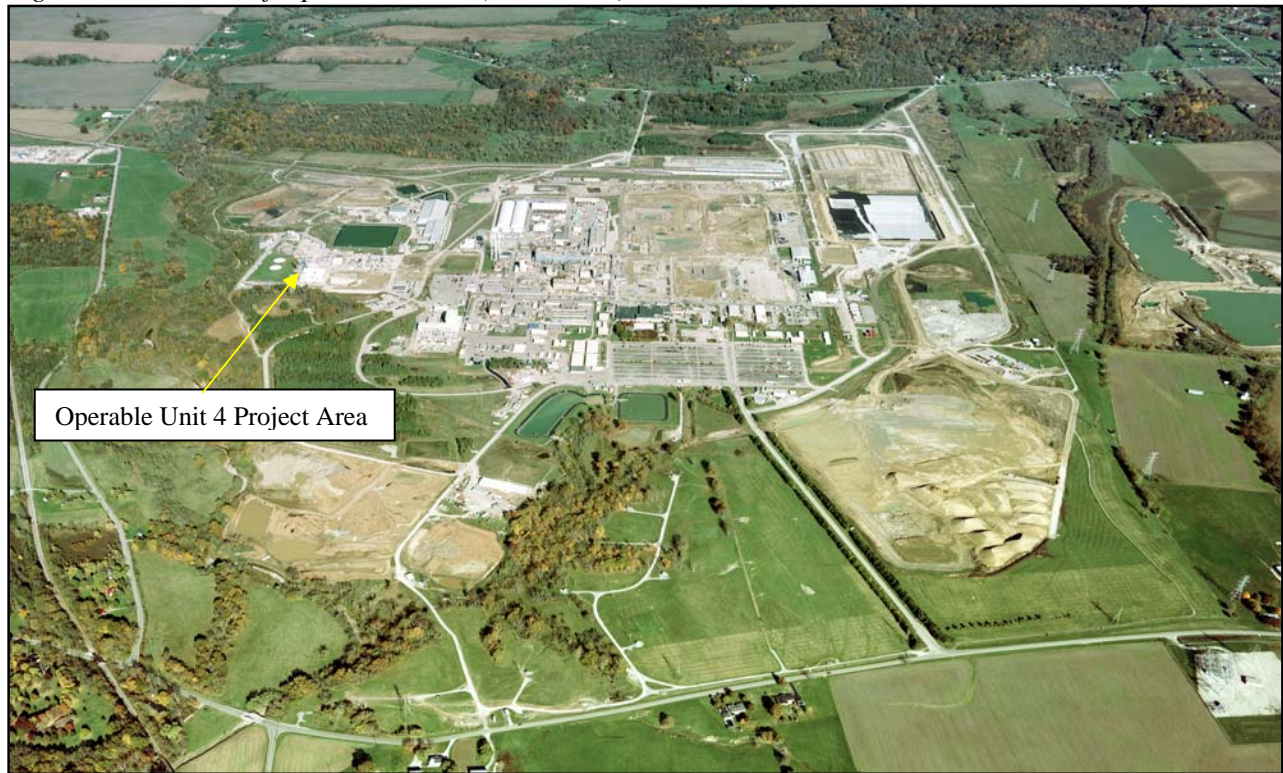

2.1 Results of the Operable Unit 4 Remedial Investigation

The goal of the RI for Operable Unit 4 was to compile existing environmental data at the site and undertake the necessary field investigations to characterize the condition and contents of Silos 1, 2, 3 and 4, the nature and extent of environmental media within the Operable Unit 4 boundary, and the risk that contaminants pose to human and environmental receptors. The RI [DOE 1993a] was conducted in accordance with the National Oil and Hazardous Substances Pollution Contingency Plan (NCP) to provide the data necessary to support the decision on whether remedial action was warranted for Operable Unit 4.

The Operable Unit 4 RI provided a detailed characterization of the source term within Operable Unit 4 and identified those contaminants that contributed to an incremental lifetime cancer risk (ILCR) value greater than 1×10^{-6} and a hazard quotient greater than 1.0. The Operable Unit 4 RI identified that the principal threats to

human health and the environment posed by Operable Unit 4 are from the following contaminant/transport pathways:

- Direct radiation, including exposure to gamma radiation from radioactive constituents within the silos, potential direct exposure to Silo 3 material under a source term scenario assuming a future structural collapse of Silo 3, and direct exposure to gamma radiation from radioactive constituents in surface soil.
- Air emissions, including dispersion of radon that escapes from the silos into the atmosphere, dispersion of volatile organic compounds (VOC) or fugitive dust generated from soil, and dispersion of Silo 3 contents under the future source term scenario assuming structural collapse of the silo.
- Surface water runoff, including erosion of contaminated soils into Paddys Run from the vicinity of the silos and erosion of released Silo 3 contents under the future source term scenario assuming structural collapse of the silo.
- Groundwater transport, including leaching of contaminants from the silo contents via soils to underlying groundwater and leaching of contaminants from the silo contents via soil to a sand silty/clay lens in the glacial till, which could carry contaminants to surface water and sediment in Paddy's Run.

The findings of the Operable Unit 4 RI, conducted in accordance with the ACA and as documented in the Operable Unit 4 FS [DOE 1994a], concluded that the existing conditions at Operable Unit 4 presented an unacceptable risk to human and environmental receptors, thereby warranting the implementation of remedial actions to address these risks.

2.2 Removal Actions

Under CERCLA, a removal action is defined as a "short-term cleanup often completed prior to a more formal ROD process." Removal actions were conducted within Operable Unit 4 as an effort to minimize or stabilize the release or threat of release of contaminants to the environment. The actions were initiated to accelerate cleanup activities to address releases or potential releases of hazardous substances from Operable Unit 4. These actions included the following:

- Removal Action No. 4 [DOE 1990b]: Installation of a BentoGrout™ clay layer over the Silos 1 and 2 material to reduce the release of radon to the environment;
- Removal Action No. 5 [DOE 1990a]: Removal of the liquid in the Decant Sump Tank to mitigate the potential for release of contaminants to sub-soils and the perched water zone; and
- Removal Action No. 21 [DOE 1991]: Removal of a dust collector containing holdup material from atop Silo 3.

Appendix D of this report provides a detailed description of these removal actions as well as a description of several actions undertaken by DOE prior to the execution of the consent agreements.

2.3 Operable Unit 4 Selected Remedy

As identified in the 1994 Operable Unit 4 ROD [DOE 1994b], key components of the selected remedy for Operable Unit 4 were:

- Removal of the contents of the Silos 1, 2, 3 and the decant sump tank sludge.
- Treatment of the Silos 1, 2, and 3 material and sludges removed from the silos and the decant sump tank by vitrification to meet disposal facility WAC.
- Off-site shipment of the vitrified contents of Silos 1, 2, 3 and the decant sump tank for disposal at the Nevada Test Site (NTS).

- Demolition of Silos 1, 2, 3 and 4 and decontamination, to the extent practicable, of the concrete rubble, piping, and other generated construction debris.
- Removal of the earthen berms and excavation of the contaminated soils within the boundary of Operable Unit 4, to achieve remediation levels. Placement of clean backfill to original grade following excavation.
- Demolition of the remediation and support facilities after use. Decontamination or recycling of debris before disposition.
- On-property interim storage of excavated contaminated soils and contaminated debris in a manner consistent with Removal Action No. 17 (Improved Storage of Soil and Debris), pending final disposition of soil and debris in accordance with the RODs of Operable Units 5 and 3, respectively.
- Continued access controls and maintenance and monitoring of the stored waste inventories.
- Institutional controls of the Operable Unit 4 area such as deed and land-use restrictions.
- Potential, additional treatment of stored Operable Unit 4 soil and debris using Operable Unit 5 and Operable Unit 3 waste treatment systems.
- Pumping and treating, as required, of any contaminated perched groundwater encountered during remedial activities.
- Disposal of the Operable Unit 4 contaminated debris and soils consistent with the RODs for Operable Units 3 and 5, respectively.

2.4 Operable Unit 4 Post-ROD Decision Changes

Five changes have been made to the Operable Unit 4 ROD subsequent to its approval in December 1994 primarily related to a required change in the implemented remediation technology from vitrification to other stabilization technologies. As discussed in Section 2.5, vitrification was deemed to be impractical.

CERCLA requires that changes to approved RODs be documented and approved through a formal ROD Amendment for changes determined to be fundamental with respect to the scope, performance, or cost of the remedy; an ESD for changes determined to be significant but not fundamental, or a Fact Sheet for minor modifications. The five post-ROD decision changes for Operable Unit 4 were:

- Explanation of Significant Differences for Operable Unit 4 Silo 3 Remedial Action [DOE 1998a], signed and effective March 27, 1998 modified the treatment component of the Silo 3 remedy to onsite or offsite treatment by chemical stabilization or polymer encapsulation, and allowed the option for disposal at a permitted commercial disposal facility in addition to the NTS.
- ROD Amendment for Operable Unit 4 Silos 1 and 2 Remedial Action [DOE 2000a], signed and effective on July 13, 2000 modified the treatment component of the Silos 1 and 2 remedy to onsite treatment by chemical stabilization.
- ROD Amendment for Operable Unit 4 Silo 3 Remedial Action [DOE 2003a], signed and effective on September 24, 2003, modified the treatment component of the Silo 3 remedy to treatment, to the degree reasonably implementable, to address material dispersability and metals mobility.
- Explanation of Significant Differences for Operable Unit 4 Silos 1 and 2 Remedial Action [DOE2003b], signed and effective November 24, 2003 removed the RCRA Toxicity Characteristic Leaching Procedure (TCLP) test as a performance standard for the chemical stabilization process (maintaining the requirement to treat by chemical stabilization to meet disposal facility waste acceptance criteria), and allowed the option for disposal at a permitted commercial disposal facility in addition to the disposal at the NTS.
- Explanation of Significant Differences for Operable Unit 4, signed and effective January 18, 2005, allowed the option for temporary offsite storage of treated Silos 1, 2, and 3 materials prior to permanent offsite disposal.

Therefore, the final remedy implemented for Operable Unit 4 defined by the Operable Unit 4 ROD and its subsequent modifications consisted of:

- Removal of the contents of Silos 1 and 2 and the Decant Sump Tank System sludge from the Silos and transfer to the Transfer Tank Area (TTA) for storage pending subsequent transfer to the Silos 1 and 2 Remediation Facility for treatment using chemical stabilization to attain the disposal facility WAC;
- Removal of material from Silo 3 by pneumatic and/or mechanical processes, followed by treatment to the extent practical by addition of a chemical stabilization reagent and a reagent to reduce dispersability; and off-site disposal at NTS or a permitted commercial disposal facility
- Off-site shipment and disposal of the treated Silo 1 and 2 materials at the NTS and/or an appropriately permitted commercial disposal facility; or, temporary offsite storage for a maximum of two years from the initiation of storage activities, if required, prior to permanent offsite disposal;
- Gross decontamination, demolition, size reduction, and packaging of the Silos 1, 2, and 3 structures and remediation facilities in accordance with the Operable Unit 3 ROD;
- Shipment of the concrete from the Silos 1 and 2 structures for off-site disposal at the NTS or an appropriately permitted commercial disposal facility;
- Disposal of contaminated soil and debris, excluding concrete from Silos 1 and 2 structures, in accordance with the FCP OSDF WAC or an appropriate off-site disposal facility, such as the NTS or a permitted commercial disposal facility;
- Removal of the earthen berms and excavation of the contaminated soils within the Operable Unit 4 boundary to achieve the soil remediation levels outlined in the Operable Unit 5 ROD;
- Appropriate treatment and disposal of all secondary wastes at either the NTS or an appropriately permitted commercial disposal facility;
- Collection of perched water encountered during remedial activities for treatment in onsite treatment facilities installed under Operable Unit 5;
- Continued access controls and maintenance and monitoring of the stored waste inventories; and
- Institutional controls of the Operable Unit 4 area such as deed and land-use restrictions.

2.5 Remedial Design Summary

The following subsections provide a brief history of the remedial design efforts undertaken for the remediation of Silo 1 and 2 and Silo 3.

2.5.1 Remedial Design for Original Operable Unit 4 Remedy

Following approval of the original Operable Unit 4 ROD, the remedial design for the selected remedy (retrieval, vitrification and offsite disposal of Silos 1, 2, and 3 materials) was initiated in accordance with the Work Plan for the Operable Unit 4 Remedial Design [DOE 1995]. As the initial step in the Operable Unit 4 remedial design process, a treatability study program was initiated in May 1996 to collect quantitative performance data to support full-scale application of the joule-heated vitrification technology to the silos material.

In December 1996, during the final stages of the last campaign to demonstrate lower temperature processing (<1200°C) of Silos 1 and 2 surrogate material, portions of the Vitrification Pilot Plant (VitPP) melter hardware failed resulting in the suspension of further testing.

Based on the recommendations of a Silos Project Independent Review Team (IRT) convened by DOE [Silos Project IRT 1997] as well as the conclusions from the evaluation of the December 1996 melter hardware

failure [DOE 1997], DOE, EPA, and key stakeholders supported a decision that vitrification of the Silo 3 material (although possible) was not practical or necessary because of its significant cost and extension to the cleanup schedule. This, and the fact that the concentrations of hazardous and radiological constituents in Silo 3 material were relatively low compared to the levels present in the Silos 1 and 2 material, became additional key factors in the decision to treat the Silo 3 material separately from the Silos 1 and 2 material. The evaluations concluded that separating the Silos 1 and 2 material from Silo 3 material would reduce the technical uncertainties and programmatic risks of developing an effective treatment process for each waste stream. Therefore, DOE and EPA made the decision, with input from the public, that Silo 3 material should be treated separately from the Silos 1 and 2 materials, and that an alternate remedy should be considered for treatment and disposal of the Silo 3 material.

2.5.2 Silo 3 Remedial Design

Following approval of the Silo 3 ESD in March 1998, the DOE submitted a Remedial Design Work Plan for Operable Unit 4 Silo 3 Remedial Action [DOE 1998b]. This work plan documented DOE's strategy for design, construction and operation of the necessary equipment and facilities for implementing the Silo 3 remedy.

The contractor-developed design for the Silo 3 remedy was documented and submitted for EPA review and approval in two separate packages. The Silo 3 Site Preparation Package [DOE 2000b] was developed to outline the design for the site clearing and grading, storm water control, and required foundations and utilities.

The design for the Silo 3 Remediation Facility to retrieve, treat, and package the Silo 3 material for offsite disposal was documented in the Silo 3 Remedial Design Package [DOE 2000c]. The primary components of the design were retrieval of the material from Silo 3 material using a reeled cable, incremental link, extending vacuuming robot (ReTRIEVR), transfer to the treatment system by way of a vacuum transfer system, and treatment of the material by mixing with Envirobond™ (a proprietary chemical stabilization formula), additives, and water in a continuous mixer. The treated Silo 3 material would then be formed into briquettes and placed in 55-gallon drums, which would be palletized and moved to the Interim Storage Area (ISA) for ultimate disposal off-site.

While the site preparation construction activities were taking place during the latter half of 2000, the turn-key Silo 3 contract was terminated by agreement and cooperation of Fluor Fernald and the contractor. The path forward for Silo 3 remediation was again reevaluated, with input from EPA, OEPA and stakeholders, due to the complexity of the design and an indication of potential operational difficulties relative to the ReTRIEVR.

During the public and regulator involvement process associated with revising the Silo 3 remedy, a decision was made to specify "treatment to the degree reasonably implementable to address material dispersability and metals mobility" as part of the remedy in response to stakeholder concerns. The revised remedy was proposed in the Revised Proposed Plan for Silo 3 [DOE 2003c] and approved in the ROD Amendment for Silo 3. The impacts to the remedial design resulting from the ROD Amendment were documented in the Silo 3 Remedial Design/Remedial Action Package, [DOE 2003d]. The major components of the approved final remedial design for Silo 3 were:

- Pneumatic (vacuum) retrieval of Silo 3 material via man ways on the silo dome;
- Cutting an opening in the silo sidewall for at-grade access by mechanical equipment;
- Mechanical retrieval of Silo 3 material using remotely controlled mechanical excavation equipment (in combination with continued pneumatic retrieval as required);

- Application of a solution of lignosulfonate, water, and ferrous sulfate to the Silo 3 material as it enters the package to reduce leachability and dispersability;
- Packaging of conditioned Silo 3 material in 96 cubic foot, double layer, coated woven polypropylene soft-sided packages (certified to meet Department of Transportation's (DOT) Industrial Package Type 2 (IP-2) requirements) with a 30 mil poly-vinyl chloride (PVC) inner liner; and
- Transportation to an offsite disposal facility(s) in accordance with DOT regulations and transportation risk criterion specified by the ROD.

2.5.3 Silos 1 and 2 Remedial Design

Reevaluation of the path forward for Operable Unit 4 resulted in a decision to separate the remediation of Silos 1 and 2 into two distinct projects. The first project, the Silos 1 and 2 Accelerated Waste Retrieval (AWR) Project, was initiated to provide facilities and equipment for transferring the material from Silos 1 and 2 and the Decant Sump Tank to a safe temporary storage while awaiting construction and startup of the Silos 1 and 2 Remediation Facility. Also included was the design of a Radon Control System (RCS) to treat radon emissions from the Silos 1 and 2 headspaces, AWR waste retrieval and storage equipment, and the Silos 1 and 2 Remediation Facility.

The AWR Project Site Preparation Package [DOE 2000d] was developed to document the site grading, utilities, foundations, and stormwater and erosion controls for the AWR Project. The design for the remainder of the AWR Project, including the RCS, the Silo Waste Retrieval System (SWRS), the TTA, and associated support systems was documented in the Silos 1 and 2 Accelerated Waste Retrieval Project Remedial Design Package [DOE 2001a]. The final design was documented in Revision 3 of the Silos 1 and 2 Accelerated Waste Retrieval Project Remedial Design Package [DOE 2002a, DOE 2003e].

The second project involved the design of the Silos 1 and 2 Remediation Facility, which was developed and documented in accordance with the Remedial Design Work Plan for the Silos 1 and 2 Project [DOE 2001b]. The approved design of the Silos 1 and 2 Remediation Facility was documented in the Silos 1 and 2 Remediation Facility Remedial Design Package [DOE 2003f]. The primary components of the design included:

- Transfer Tank Waste Retrieval System (TWRS) for the transfer of slurried material from the TTA to the Silo 1 and 2 Remediation Building.
- Feed Preparation System for mixing additives with the slurried material and processing the material through a clarifier to thicken the slurry to approximately 30 weight-percent solids in preparation for product mixing.
- Processor Feed System used to continuously receive thickened material and then transfer the material by batches to the product mixers.
- Product Additive System for the receipt, storage, and delivery of cement and fly ash to the product mixers.
- Processor System used to mix the thickened slurry with cement and fly ash on a batch basis and discharge of this treated material to the disposal containers.
- Container Handling System for the receipt, preparation, and filling of the containers.
- Disposal Containers designed to be a 6-foot diameter, 6.5-foot high, half-inch thick, cylindrical carbon steel container with an external volume of 196 cubic feet (internal volume of approximately 187 cubic feet). The container was designed and tested to meet DOT's Industrial Package Type 2 (IP-2) requirements.

3.0 CONSTRUCTION ACTIVITIES

Field activities relative to the scope of the Operable Unit 4 remedy involved seven primary scopes of work:

- Site Preparation
- Vitrification Pilot Plant Construction
- Silo 3 Remediation Facility Construction
- Silos 1 and 2 Accelerated Waste Retrieval (AWR) and Radon Control System (RCS) Construction
- Silos 1 and 2 Remediation Facility Construction
- Waste Retrieval and Disposition
- Silos Wastewater Treatment Facility Construction

Several pictures of the constructed facilities are located in Appendix G of this report.

3.1 Site Preparation

Fieldwork implementing the Operable Unit 4 remedy was initiated with the Site Preparation and Underground Utilities (SP/UU) Project in March 1996, satisfying the CERCLA criterion for initiation of remedy implementation within 15 months of ROD approval. This site preparation activity involved the installation of utilities to support future remediation facility operation, as well as site grading, runoff control, and installation of a storm water detention basin at the southeast corner of the Operable Unit 4 area.

Construction activity for the Silos Infrastructure Project took place during the summer and fall of 1999 to provide roadways, additional storm water drainage features, and electrical systems to support future construction and operation of the Operable Unit 4 remediation facilities. The primary feature installed under the Silos Infrastructure Project was a 3500-foot blacktop two-lane road around the perimeter of the Operable Unit 4 area to provide access by construction equipment during construction of the remediation facilities, and to facilitate future access during shipment of treated Silo materials for offsite disposal. In addition to road construction, the infrastructure project included clearing of the project area, installation of catch basins, culverts and finished grading for stormwater drainage, installation of power and lighting, and relocation of the camera tower south of Silo 1.

3.2 Vitrification Pilot Plant Construction

As part of the Operable Unit 4 remedial design process, the VitPP was constructed during 1995 and 1996 in order to collect quantitative performance data to support full-scale application of the vitrification technology to the silos material. The primary component of the VitPP was a one metric ton per day, electrically powered (joule-heated) melter. The remainder of the facility consisted of ancillary systems supporting operation of the melter. The melter feed system consisted of tanks, pumps, and associated piping used to prepare surrogate feed slurries and feed them to the melter. The primary and emergency off-gas systems consisted of a scrubber, desiccant tower, quench tower, high efficiency particulate air (HEPA) filters, and associated ductwork. The VitPP operated between June and December 1996 processing non-radioactive surrogate materials representing the physical and chemical properties of the Silo material. Between 1997 and 1999, the melter, feed and offgas system equipment, and associated waste materials were removed and disposed offsite. The VitPP building was later converted for use as an operations and maintenance building and control room to support operations activities associated with the AWR and RCS systems.

3.3 Silo 3 Remediation Facility Construction

Site preparation construction for the Silo 3 Remediation Facility began in June 2000 and consisted of site grading, utility installation, and the construction of the ISA pad immediately east of Silo 3. The construction of the Silo 3 Remediation Facility began in April 2003 and included.

- A fabric membrane enclosure over Silo 3 for weather protection during pneumatic retrieval operations on the silo dome
- Container loading area outside the cargo bay for loading filled containers onto trucks
- Concrete excavator building to house the remotely controlled excavator and enclose the Silo 3 east sidewall where the opening for mechanical retrieval would be made.
- Process building to house the pneumatic and mechanical retrieval system components, packaging systems, additive system, wastewater tank, heating, ventilation and air conditioning, and process vent system used for equipment and area dust collection.
- Cargo bay adjacent to the process building for preparing empty containers for filling, surveying, closing and labeling filled containers.
- An air handling equipment pad for the air handling and air emissions control equipment

3.4 Accelerated Waste Retrieval and Radon Control System Construction

Construction of the Silos 1 and 2 AWR systems began in June 2000 and was completed in 2004. Because of the radiological hazards associated with the Silo 1 and 2 material, extensive use of shielding was used to minimize exposures to personnel in the vicinity of the TTA. Slurry transport piping from Silos 1 and 2 to the TTA tanks was double contained. Features such as remote operation, glove-ports and windows for maintenance, and secondary containment were incorporated into the construction. The major components of the Silos 1 and 2 AWR system included:

- The TTA, consisting of four 750,000 gallon steel tanks housed in a concrete shielding structure
- The Silo Waste Retrieval System (SWRS), consisting of piping and equipment for the retrieval of the material from Silos 1 and 2 and transfer to the TTA
- The Transfer Tank Waste Retrieval System (TTWRS) consisting of equipment identical to the SWRS, for retrieving the material from the TTA and transferring it to the future Silos 1 and 2 Remediation Facility
- A Test Stand consisting of a steel tank and Sluice/Slurry Module support structure used to test and demonstrate Silo waste retrieval equipment and methods using non-radioactive, non hazardous surrogate material

The Radon Control System consisted of an exhaust stack, an air handling building housing the chillers, desiccant dryers, and HEPA Filters, and four carbon beds, housed in concrete shielded vaults, each containing approximately 46,000 pounds of activated carbon. Construction of the RCS was completed in early 2003.

3.5 Silos 1 and 2 Remediation Facility Construction

Construction of the Silos 1 and 2 Remediation Facility took place between July 2002 and February 2005.

Because of the radiological hazards associated with the silos material, extensive shielding was used to minimize exposures to personnel working within and in the vicinity of the Remediation Facility. Slurry transport piping from the TTA tanks to the Silos 1 and 2 Remediation Facility was double contained. The major systems constructed include:

- Slurry receipt tanks consisting of three, 75,000-gallon carbon steel tanks within a shielded enclosure
- Feed preparation system consisting of polymer feed tanks, reaction tank and polymer addition tank and the clarifier. The clarifier was a 14.5-ft diameter gravity thickener with 10-ft sides and a 9-ft bottom cone section.

- Processor feed system consisting of three 24,700 gallon carbon steel tanks within a shielded vault
- Product additive system consisting of cement handling and fly ash handling equipment able to receive bulk cement and fly ash and deliver these additives in a controlled manner to the batch mixers
- Processor system consisting of three carbon steel horizontal double-ribbon mixers used to mix the thickend slurry with the product additives and deliver the mixture to a container via a product fill chute
- Container handling system containing equipment, controls and rooms for empty container receiving, staging, and preparation; container identification; container filling, transfer, and inspection; lidding and fastening; and loading of product containers on trucks.

3.6 Waste Retrieval and Disposition

3.6.1 Silo 3 Waste Retrieval and Disposition

Pneumatic retrieval, conditioning, and packaging of Silo 3 material was initiated March 23, 2005. A total of 1,416 containers were filled via pneumatic retrieval through October 21, 2005, when mechanical retrieval was initiated. Retrieval and packaging of Silo 3 material was completed March 21, 2006. A total of 2,297 containers were filled (including 50 containers of material generated during safe shutdown of the facility) and transported to Envirocare in Clive, Utah for disposal.

3.6.2 Silo 1 & 2 Waste Retrieval and Disposition

Bulk retrieval and transfer of material from Silo 1 and 2 and the Decant Sump Tank to the AWR TTA was initiated September 22, 2004 and was completed March 1, 2005. During that period, a total of approximately 2.2 million gallons of slurried silo material, and an additional 400,000 gallons of water were transferred to the four TTA tanks. The Silo 1 and 2 structures were demolished in April 2005 following completion of the waste retrieval and transfer operations.

Treatment and packaging of the Silo 1 and 2 material in the Remediation Facility was initiated May 19, 2005, and the first shipment of treated Silos 1 and 2 material to Waste Control Specialists (WCS) in Andrews, Texas for temporary storage left the FCP on June 6, 2005.

Bulk processing in the Silos 1 and 2 Remediation Facility was completed March 19, 2006. A total of 3,776 containers of treated Silo 1 and 2 material (including 80 containers produced through direct load out in support of safe shutdown of the facility) were packaged and shipped to WCS for temporary storage, pending permanent disposal. The RCS, which initiated Phase 1 operation on April 25, 2003 to remove radon from the Silos 1 and 2 headspaces, provided control of radon and particulate emissions from the SWRS equipment, TTA tanks, and process vessels in the Silos 1 and 2 Remediation Facility until it was shut down on April 1, 2006.

3.7 Silos Wastewater Treatment Facility Construction

Excess wastewater from operations, as well as water needed to flush the system components during safe shutdown of the Silo 1 and 2 Remediation Facility, presented several unique treatment difficulties necessitating the installation of a treatment system dedicated to this waste stream. The significant radium concentration associated with the Silo 1 and 2 material and the high concentrations of certain ions proven to be detrimental to the ion exchange resin used for uranium removal at the Converted Advanced Wastewater Treatment (CAWWT) system required a separate facility for processing of silos wastewater. The existing South Plume Interim Treatment System (SPIT) was modified to provide this treatment capability. This modified facility was designed and

constructed to receive wastewater from the Silos facilities, via tanker truck, that had been treated with lime and filtered for gross solids removal. The modifications at the SPIT facility included:

- The relocation of bag and cartridge filters from the Interim Advanced Wastewater Treatment System to remove trace solids
- The conversion of the existing SPIT multi-media filters to granular activated carbon vessels
- The use of existing SPIT ion exchange vessels but replacing the resin used for uranium removal with resin used for radium removal

The modifications were initiated in December 2005. Processing operations began in March 2006 and were completed in May 2006. A total of approximately 251,000 gallons of wastewater were processed.

4.0 CHRONOLOGY OF EVENTS

The following table provides a summary of the events for Operable Unit 4 remediation, and associated dates of those events. The dates shown for Remedial Design/Remedial Action documents reflect the date of EPA approval of the final revision of the document.

Table 4-1 Summary of Events for Operable Unit 4 Remediation	
Event	Date
Operable Unit 4 Decision Related Documents	
Approval of Operable Unit 4 Record of Decision	December 1994
Approval of Explanation of Significant Differences for Silo 3	March 1998
Approval of Record of Decision Amendment for Silos 1 and 2	July 2000
Approval of Record of Decision Amendment for Silo 3	September 2003
Approval of Explanation of Significant Differences for Silos 1 and 2	November 2003
Approval of Explanation of Significant Differences for Operable Unit 4	January 2005
Operable Unit 4 Remedial Design Documents	
Remedial Design Work Plan for Remedial Actions at Operable Unit 4	June 1995
Vitrification Pilot Plant Treatability Study Work Plan	June 1996
Remedial Design Work Plan for Silo 3	June 1998
Silo 3 Site Preparation Package	April 2000
Silos 1 and 2 Accelerated Waste Retrieval Project Site Preparation Package	May 2000
Remedial Design Work Plan for Silos 1 and 2	October 2001
Remedial Design Package for Silos 1 and 2 Accelerated Waste Retrieval (includes RCS design)	October 2002
Remedial Design Package for Silos 1 and 2	June 2003
Remedial Design / Remedial Action Package for Silo 3	February 2004
Operable Unit 4 Remedial Action Documents	
Remedial Action Work Plan for RCS Phase 1	October 2002
Remedial Action Work Plan for Silos 1 and 2 Waste Retrieval Operations	October 2003
Remedial Action Work Plan for Silo 3 (combined with RD/RA Package)	February 2004
Remedial Action Work Plan for Silos 1 and 2 Remediation Facility	October 2004
Silo 3 Transportation and Disposal Plan	March 2005
Silos 1 and 2 Transportation and Disposal Plan	May 2005
Remedial Action Field Activities	
Removal Action No. 4 (Bentonite addition to Silo 1 and 2)	November 1991
Removal Action No. 21 (Silo 3 Dust Collector Removal)	December 1991
Initiation of Vitrification Pilot Plant Operations	July 1996
Failure of Vitrification Pilot Plant Melter hardware	December 1996
Initiation of Site Preparation Construction (Silos Infrastructure Project)	April 1999
Initiation of Silo 3 Remediation Facility Construction	June 2000
Initiation of Radon Control System / Silos 1 and 2 AWR Construction	July 2000
Initiation of Silos 1 and 2 Remediation Facility Construction	July 2002
Initiation of Radon Control System Phase 1 Operation	April 2003



Table 4-1 Summary of Events for Operable Unit 4 Remediation (continued)

Event	Date
Initiation of Silos 1 and 2 Waste Retrieval	September 2004
Completion of Silos 1 and 2 Waste Retrieval and Decant Sump Tank Sludge Removal	March 2005
Initiation of Silo 3 Remediation Facility Operation	March 2005
Decontamination and Demolition of Silo 1 and 2 Structures	April 2005
Initiation of Silos 1 and 2 Remediation Facility Operation	May 2005
Completion of Disposal of Silo 3 material at Envirocare	April 2006
Completion of Transportation of Treated Silos 1 and 2 Material to WCS for Temporary Storage	May 2006
Initiation of Final Disposal of Silos 1 and 2 Material	TBD
Completion of Final Disposal of Silos 1 and 2 Material	TBD



5.0 PERFORMANCE STANDARDS AND CONSTRUCTION QUALITY CONTROL

The Operable Unit 4 remediation facilities were designed, constructed, inspected, tested, operated, and controlled under Fluor Fernald's *Quality Assurance Program Requirements Manual, RM-0012*. The standards for quality reflected in RM-0012 were derived from Department of Energy Regulations at 10 CFR Part 830 Subpart A, *Quality Assurance Requirements*. Fluor Fernald's Quality Assurance Program also incorporates appropriate requirements from DOE's *Quality Assurance Management System Guide for use with 10CFR 830.120 (G 414.1-2)*. This program specified standards by which systems were designed, procured, installed, tested and operated.

Environmental data used to support the design and operation of the Operable Unit 4 remedy were collected in accordance with the Site-Wide CERCLA Quality Assurance Project Plan (SCQ). The SCQ was developed for FCP environmental sampling and analysis with a two-fold purpose: (1) establish minimum standards of performance for operational and analytical activities, and (2) ensure that parties covered by the plan follow those standards. The SCQ integrates CERCLA requirements into applicable sampling activities at the FCP.

Operation of the remedy has been implemented through staffing the facilities with trained operators and supervisors who were guided by standard operating procedures for operation of equipment and systems. Equipment and systems were maintained through a regimented preventative maintenance system. All operational and maintenance activities were implemented through formal Conduct of Operations protocols per Fluor Fernald's *Conduct of Operations Program Requirements Manual, RM-0029* derived from DOE Order 5480.19.

5.1 Silo 3 Performance Standards

The packaging requirement for the Silo 3 material is an IP-2 container. Soft-sided IP-2 containers were used to containerize the Silo 3 material for staging and subsequent shipment. The containers were tested per DOT methods (drop and stacking tests) to verify DOT requirements for an IP-2 package. The containers were placed on pallets to facilitate handling and loading into ISO containers and then loaded onto flatbed trailers. Securing the soft-sided containers within the ISO and securing the ISO containers on the flat bed truck followed DOT requirements. Containers were inspected prior to filling by QC personnel. QC personnel also inspected the loaded trailers prior to leaving the FCP. The shipping followed a pre-determined route approved in the Silo 3 Transportation and Disposal Plan [DOE 2005d]

The performance standards for the Silo 3 remedy consisted of compliance with the waste profile for 11e.(2) material at Envirocare [Envirocare 2005]. Process control data and radiological sample data were collected for each container to demonstrate compliance with this waste profile. Table 5-1 summarizes this data.

5.2 Silo 1 and 2 Performance Standards

The packaging requirement for the Silo 1 and 2 materials is an IP-2 container. The containers were tested per DOT methods (drop, vibration, and stacking tests) to verify DOT requirements for an IP-2 package. The containers were secured to a flat bed truck, each truck capable of handling two containers, in accordance with DOT requirements. Containers were inspected, prior to filling, by Fluor Fernald Quality Control (QC) personnel. QC personnel also inspected the loaded trailers prior to leaving the FCP. The shipping followed a pre-determined route approved in the Silo 1 and 2 Transportation and Disposal Plan [DOE 2005c]

The performance standards to be met for the treated Silo 1 and 2 materials involved complying with the waste profile [WCS 2005] established for temporary storage at WCS in Andrews, Texas (the material also complied

with the NTS WAC as a potential final disposal facility). Process control to achieve the necessary standards was obtained based upon analysis of radium-226 content in input feed batches, actual and historical data on the performance of the stabilization recipe, and historical analysis of Silos 1 and 2 material. Feed batch data, recipe formulation data and process control data for each container produced was collected to demonstrate compliance with this waste profile. Table 5-2 summarizes the data in support of compliance with this profile. Table 5-3 summarizes the data in support of compliance with the NTS WAC.

Table 5-1 Silo 3 Profile Compliance Summary

	Summary of Silo 3 Material Concentrations		Envirocare Waste Profile
	Maximum (pCi/g)	Minimum (pCi/g)	Concentration Range (pCi/g)
Thorium-230	57,220	4,200	17,850 – 60,000
Thorium-232	693	56	350 – 6,000
Radium-226	3,992	749	395 – 4,000
Protactinium-231	880	69	200 – 4,000
Natural Uranium	3,988	1,209	600 – 4,000

Table 5-2 Silo 1 and 2 Profile Compliance Summary

	Summary of Silo 1 and 2 Material Concentrations		WCS Waste Profile
	Maximum (pCi/g)	Minimum (pCi/g)	Concentration Range (pCi/g)
Thorium-230	13,985	544	1,220 – 68,200
Radium-226	93,795	3,648	8,630 – 176,000
Actinium-227	1,573	1,573	206 – 11,300
Protactinium-231	1,573	1,573	206 – 11,300
Polonium-210	93,795	3,648	8,630 – 176,000

Table 5-3 Silo 1 and 2 NTS WAC Compliance Summary

	Summary of Silo 1 and 2 Material Concentrations		NTS WAC
	Maximum (Bq/m ³)	Minimum (Bq/m ³)	Concentration Range (Bq/m ³)
Thorium-230	4.5E+07	7.3E+08	6.5E+07 – 3.8E+09
Thorium-232	4.6E+05	7.3E+06	7.1E+05 – 5.6E+07
Radium-226	3.0E+08	4.9E+09	4.6E+08 – 9.8E+09
Lead-210	3.0E+08	4.9E+09	4.6E+08 – 9.8E+09
Actinium-227	3.0E+07	1.2E+08	1.1E+07 – 6.3E+08
Protactinium-231	3.0E+07	1.2E+08	1.1E+07 – 6.3E+08

6.0 FINAL INSPECTIONS AND CERTIFICATIONS

The scope of this Final Remedial Action Report for Operable Unit 4 is to demonstrate that all of the residues contained in Silos 1, 2, and 3 and the Decant Sump tank have been retrieved, processed and removed from the site in accordance with the ROD for Operable Unit 4 and its subsequent revisions.

As described in Section 3 of this report, all of the residues in Silos 1 and 2 and the Decant Sump Tank were retrieved from the silos, transferred to the TTA facility, and subsequently processed, packaged, and removed from the FCP in accordance with the approved Remedial Design/Remedial Action Documentation. The silo structures were decontaminated and demolished in April 2005.

A total of 3776 containers of treated Silos 1 and 2 residues were transported to the WCS facility in Andrews, Texas for temporary storage. Each shipment was manifested to ensure that all of the Silos 1 and 2 residues were properly shipped and received by the facility. As of the date of this Final Remedial Action Report, the license application for permanent disposal of the Silos 1 and 2 residues at WCS was in the final review and approval process, with disposal targeted to begin in early 2007. In accordance with the January 2005 ESD for Operable Unit 4, DOE will accomplish permanent disposal of the Silos 1 and 2 residues either at WCS, or another appropriately licensed commercial or government-owned facility, by June 7, 2007 (the date established in the ESD as two years from the initiation of storage activities).

All of the residues in Silo 3 were retrieved using vacuum or mechanical retrieval, processed and packaged in accordance with the September 2003 Record of Decision Amendment for Silo 3, and transported to Envirocare for permanent disposal. Each shipment was manifested to ensure that all of the Silo 3 residues were properly shipped, received and disposed by the facility.

The necessary information to provide certification that the treated Silo 1 and 2 material has been permanently disposed in accordance with the ROD for Operable Unit 4 will be included in final Remedial Action Report for Operable Unit 4, which will be submitted as a post-closure submittal. As detailed in Figure 1-1, certification that the remaining portions of the Operable Unit 4 remedy have been completed will be provided in the Interim Remedial Action Report for Operable Unit 5 (soil remediation) and the Final Remedial Action Report for Operable Unit 3 (facility D&D).

7.0 OPERATION AND MAINTENANCE ACTIVITIES

As a removal and disposal remedy, there are no post-remedy operational issues or requirements for the silos area within the Operable Unit 4 boundary. Because certification activities for the underlying soils of the silos area have yet to be initiated, maintenance activities for this footprint are related to establishing the necessary boundary control to limit access during soil excavation and certification activities and preventing recontamination once certification activities are underway. When certification is complete, restoration will be accomplished as part of the Operable Unit 5 resource restoration activities.

Maintenance of restored areas prior to closure is described in the individual restoration design packages. The following are the general maintenance activities that will be carried out in each restored area:

- Controlling invasive/noxious species by spot removal using manual, mechanical, or chemical methods.
- Reseeding and/or replanting of restored areas as required by implementation monitoring and adaptive management decisions to ensure appropriate vegetative cover.
- Maintaining prairie and savanna ecosystems and diversity through appropriate disturbance regimes and thatch removal. Activities may include mowing, burning, or physical disturbance.
- Correcting soil erosion problems at drainage channels, stream banks, outfall structures, or wetland berms by appropriate means that are impacting or have the potential to impact restored areas.
- Repairing wildlife structures/boxes as needed.
- Clearing debris, tripping hazards, overhanging limbs, excessive weed growth, and replacing mulch on pathways and public access areas.
- Keeping access points and parking areas in good condition including the replacement of gravel and mowing and trimming as appropriate.

Legacy management is required at the FCP to ensure that the remedial actions implemented at the site continue to be effective and protective of human health and the environment. Legacy management in restored areas will include ensuring that natural and cultural resources are protected in accordance with applicable laws and regulations. Institutional controls will also be implemented to limit access and land use. Institutional controls include continued federal ownership of the FCP and placing restrictions on the use of the property on the property deed before the property could be sold or transferred to another party. All the legacy management and institutional control requirements and initiatives are defined in the Comprehensive Legacy Management and Institutional Controls Plan (LMICP) [DOE 2006]. Since the LMICP is applicable to the FCP as a whole, there are no specific institutional controls related to Operable Unit 4.

8.0 SUMMARY OF PROJECT COSTS

The total cost of the Operable Unit 4 Remedy, including the direct, indirect, and operation and maintenance costs associated with the retrieval, processing, packaging, and shipping of the waste material located in Silos 1 and 2 and Silo 3 was \$588.3 million dollars. This cost does not include the costs associated with the D&D of the silos or the remediation facilities, nor does it include the costs of the remediation of the underlying soils within the Operable Unit 4 boundary.

The estimated cost of the Operable Unit 4 remedy detailed in the original Operable Unit 4 ROD was \$96.7 million dollars. This original cost estimate was based on removal, vitrification, and off-site disposal at NTS for both the Silos 1 and 2 and Silo 3 material (Alternatives 3A.1 and 3B.1 from the Operable Unit 4 ROD respectively). Appendix A provides a breakdown of the actual and ROD estimated costs.

A review of the regulatory history and remedial design history described in Section 2 and 3 of this report provides an indication of the reasons for the difference in actual costs versus those estimated in the Operable Unit 4 ROD in 1994. The reasons can be summarized as follows:

- Unsuccessful efforts to design and operate a vitrification process resulting in a remedy change from vitrification to a chemical stabilization process (Silo 1 and 2) and conditioning process (Silo 3).
- The separation of Silos 1 and 2 and Silo 3 into separate treatment processes requiring separate remediation processing infrastructure. The original cost estimate assumed common costs for processing facilities and packaging and transportation facilities.
- The decision to add interim storage of retrieved material from Silos 1 and 2 via the AWR project.
- Unsuccessful attempts at fixed price/performance based contracts for both the AWR and Silo 3 projects.

9.0 OBSERVATIONS AND LESSONS LEARNED

Lessons learned from Operable Unit 4 remedial activities include:

- Parallel design / construction processes - The designs for the Operable Unit 4 remediation facilities were subdivided into discrete packages to allow initial construction activities for initial packages (site preparation, support facilities, etc.) to commence and continue while design of the subsequent packages were being finalized. While this fast track approach proved to be a valuable tool in maintaining an accelerated cleanup schedule, it presented significant challenges in the following areas:
 - Maintaining integration between packages to minimize the need for rework, and the resulting schedule and cost increases as design and construction proceeds
 - Maintaining coordination with regulators, and external stakeholder groups to allow sufficient formal and informal input review and approval while minimizing schedule impact
 - Adequately addressing constructability, operations & maintenance, and safety requirements early in the design phase of initial packages
 - Incorporating the necessary flexibility into the design of early packages to address uncertainty in the ultimate configuration of later packages.
- Consideration of D&D during facility design – Considering D&D issues, such as minimizing size and complexity of equipment, ease of decontamination, and preventing spread of contamination during operations and material handling, during the design of the Operable Unit 4 remediation facilities yielded significant cost and schedule benefits during the final D&D phase of the project.
- Use of outside independent industry expertise – Input from outside experts in areas such as material handling, and waste treatment technologies and equipment, from both within the DOE complex and from outside industry, was incorporated throughout the remedy selection, design, and operation phases of Operable Unit 4 remediation. Independent review teams were utilized to assess and provide recommendations at key decision points during design, construction and startup, and input from equipment vendors was incorporated directly into the design process. An example of this type of review was the Reliability, Accessibility, and Maintainability reviews conducted by the Critical Analysis Team. This input from independent review teams provided a valuable resource in the decision-making and design process, and also proved very beneficial in maintaining regulator and stakeholder support.
- Fixed price/performance-based design & construction contracts_ - Fixed price/performance based contracts were originally awarded for “turn-key” design, construction, and operation of both the Silo 3 and Silos 1 and 2 AWR contracts. Although originally anticipated to minimize cost by incentivizing the contractor to develop innovative ways to meet the project objectives, both of these contracts were ultimately unsuccessful. Valuable lessons were learned, however, regarding the use of this contract vehicle. Success of the fixed price contract is largely dependant upon:
 - The ability of the procurement team to identify and document the project design basis and technical requirements in sufficient detail for adequate understanding by potential vendors
 - The magnitude of changes in technical requirements, scope, or schedule resulting from unanticipated requirements or influence from entities such as stakeholders and regulators, that occur after contract award.
- Process Demonstration / Mock-up testing - Mockup testing of key equipment during the design and component selection process, as well as integrated demonstration of both individual systems and entire facilities prior to startup, were key ingredients in the successful startup and operation of the Silo 3, AWR, and Silos 1 and 2 Remediation Facilities.

10.0 CONTACT INFORMATION

Remedial Action Contacts

<p>U.S. Department of Energy Contact Public Information Fernald Closure Project U.S. Department of Energy P.O. Box 538705 Cincinnati, OH 45253-8705 513-648-3153</p>	<p>Fluor Fernald Contact Fernald Closure Project Fluor Fernald P.O. Box 538704 Cincinnati, OH 45253-8704 513-648-4898</p>
<p>U.S. Environmental Protection Agency Contact Remedial Project Manager U.S. EPA SRF-6J 77 W. Jackson Blvd. Chicago, IL 60604-3590 312-886-0992</p>	<p>Ohio Environmental Protection Agency Contact Fernald Project Manager Ohio Environmental Protection Agency 401 E. Fifth St. Dayton, OH 45402-2911 937-285-6357</p>



APPENDIX A – COST AND PERFORMANCE SUMMARY

The cost and performance of the Operable Unit 4 remedy is presented and discussed from two perspectives. First, costs are presented in terms of the overall remedy costs. The 1994 Operable Unit 4 ROD cost information was used as the basis for comparison with the actual total costs experienced through the completion of the shipment of the silo material. Table A.1-1 provides this information for Silos 1 and 2 while Table A.1-2 provides this information for Silo 3.

Table A.1-1 Silo 1 and 2 Total Remedy Costs (in millions)

Scope	Total Actual Cost	Total ROD Cost Estimate (Unescalated)	Total ROD Cost Estimate (Escalated)
Direct & Capital Cost	\$193.5	\$20.6	22.9
Indirect Costs*	\$223.8	\$17.7	19.7
Operations & Maintenance	\$71.3	\$11.7	13.0
Silo 1/2 Remedy TOTAL	\$488.6	\$50.0	\$55.6

*Includes transportation and disposal costs

Table A.1-2 Silo 3 Remedy Costs (in millions)

Scope	Total Actual Cost	Total ROD Cost Estimate (Unescalated)	Total ROD Cost Estimate (Escalated)
Direct & Capital Cost	\$16.7	\$14.9	19.3
Indirect Costs*	\$70.4	\$11.9	15.4
Operations & Maintenance	\$12.6	\$4.9	6.4
Silo 3 Remedy TOTAL	\$99.7	\$31.7	\$41.1

* Includes transportation and disposal costs

The second perspective is the cost performance perspective of the remedy actually implemented. To make this comparison, the cost estimates from the appropriate decision document was used as the basis for comparison and actual costs were accumulated based on whether the cost under consideration was a part of the final selected remedy.

For Silo 1 and 2 the basis of comparison was the estimated costs provided in the July 2000 ROD Amendment (Table 4.2-1, pg. 4-9). Actual costs excluded from the evaluation included all costs associated with vitrification, accelerated waste retrieval and proof of principle testing. Table A.1-3 provides this comparison.

The basis for comparison for Silo 3 was the estimate provided in the September 2003 ROD Amendment for Silo 3 (Summary Cost Data, pg. 5-10). No actual costs needed to be excluded to make a direct comparison to the estimate in the proposed plan. Table A.1-4 provides the comparison for Silo 3. The difference in actual costs presented in Table A.1-2 and Table A.1-4 involve costs associated with the failed subcontracting effort discussed in Section 2.5.2 of this report. These costs were excluded from Table A.1-4.

Table A.1-3 Silo 1 and 2 Chemical Stabilization Remedy Costs (in millions)

	Silo 1 and 2 Estimated Costs from the Silo 1 and 2 ROD Amendment	Actual Costs*
Direct & Capital Cost	\$55	\$78.0
Indirect Costs	\$45	\$55.2
Operation & Maintenance	\$77	\$49.0
Transportation & Disposal	\$58	\$62.4**
Total	\$235***	\$244.6

*Actual costs include shared costs with the Silo 3 project for oversight and management

**Additional costs will be realized upon final disposal

*** Costs for D&D and the cost of money eliminated from the evaluation

Table A.1-4 Silo 3 Chemical Conditioning Remedy Costs (in millions)

	Silo 3 Estimated Costs from the Silo 3 ROD Amendment	Actual Costs*
Direct & Capital Cost	\$14	\$19.0
Indirect Costs	\$15	\$44.4
Operation & Maintenance	\$4	\$16.1
Transportation & Disposal	\$7	\$10.1
Total	\$40**	\$89.6

*Actual costs include shared costs with the Silo 3 project for oversight and management

** Costs for D&D and the cost of money eliminated from the evaluation

Cost growth in direct capital construction and indirect costs was experienced in the selected remedy for Silos 1 and 2 Remedial Action. The capital cost growth was attributed to:

- The need to increase the waste treatment capacity of the facility to accommodate a compressed operational schedule;
- The need to install redundant transportation infrastructures supporting both rail and truck transport modes;
- The need for facility modifications to accommodate more remote operations in response to As Low As Reasonably Achievable (ALARA) based worker dose analyses; and
- The need for capital improvements following startup to address identified safety and operational deficiencies.

The growth in indirect costs was attributed to the need for increased quality and safety oversight during the startup and operation of the facility over and above the level originally estimated. Increased oversight was deemed necessary so as to maintain disposal documentation and a heightened level of waste container quality control to ensure its acceptability for final disposal at a number of commercial and federal disposal facilities. Increased safety oversight was deemed appropriate based on the identified facility hazards following detailed safety and nuclear systems analysis.

Cost growth was also experienced in the selected remedy for the Silo 3 Remedial Action as a result of significant changes in the level and type of oversight provided to the waste treatment and packaging operation, significant changes in the required waste retrieval approach due to the as found conditions of the waste, and increases in

commercial vendor waste disposal costs as compared to the original estimate. Following detailed hazards and safety analysis it was deemed necessary to provide significant increases to the level and manner in which oversight was conducted on the Silo 3 project. Lessons learned on other projects at the FCP pointed to the need to implement a robust radiological monitoring program including significant radiological control technician coverage and a comprehensive air monitoring program to ensure exposures to the workers were kept to ALARA levels and positive containment of the material was maintained.

Due to the process of retrieving the material from Silo 3 it was discovered that the material in the bottom third of the silo had become densely packed rendering it not conducive to vacuum retrieval. As a result, alternate means of waste retrieval were implemented including use of a remote excavator. The need for the remote excavator was not envisioned at the time of the original RI/FS estimate.

The actual cost for waste disposal for Silo 3 material was found to be 15-percent higher than originally contemplated. This increase in waste disposal costs was attributed to the need for alternate handling methods at the receiver site to accommodate improvements in the methods for the control of airborne contamination during waste placement.

APPENDIX B – SCHEMATIC OF TREATMENT SYSTEMS

Schematics of the treatment systems implemented for the Operable Unit 4 remedy are depicted on the following pages.

Figure B-1 – Accelerated Waste Retrieval and Radon Control System Process Flow

Figure B-2 – Silos 1 and 2 Remediation Process

Figure B-3 – Silos Wastewater Treatment Process

Figure B-4 – Silo 3 Remediation Process

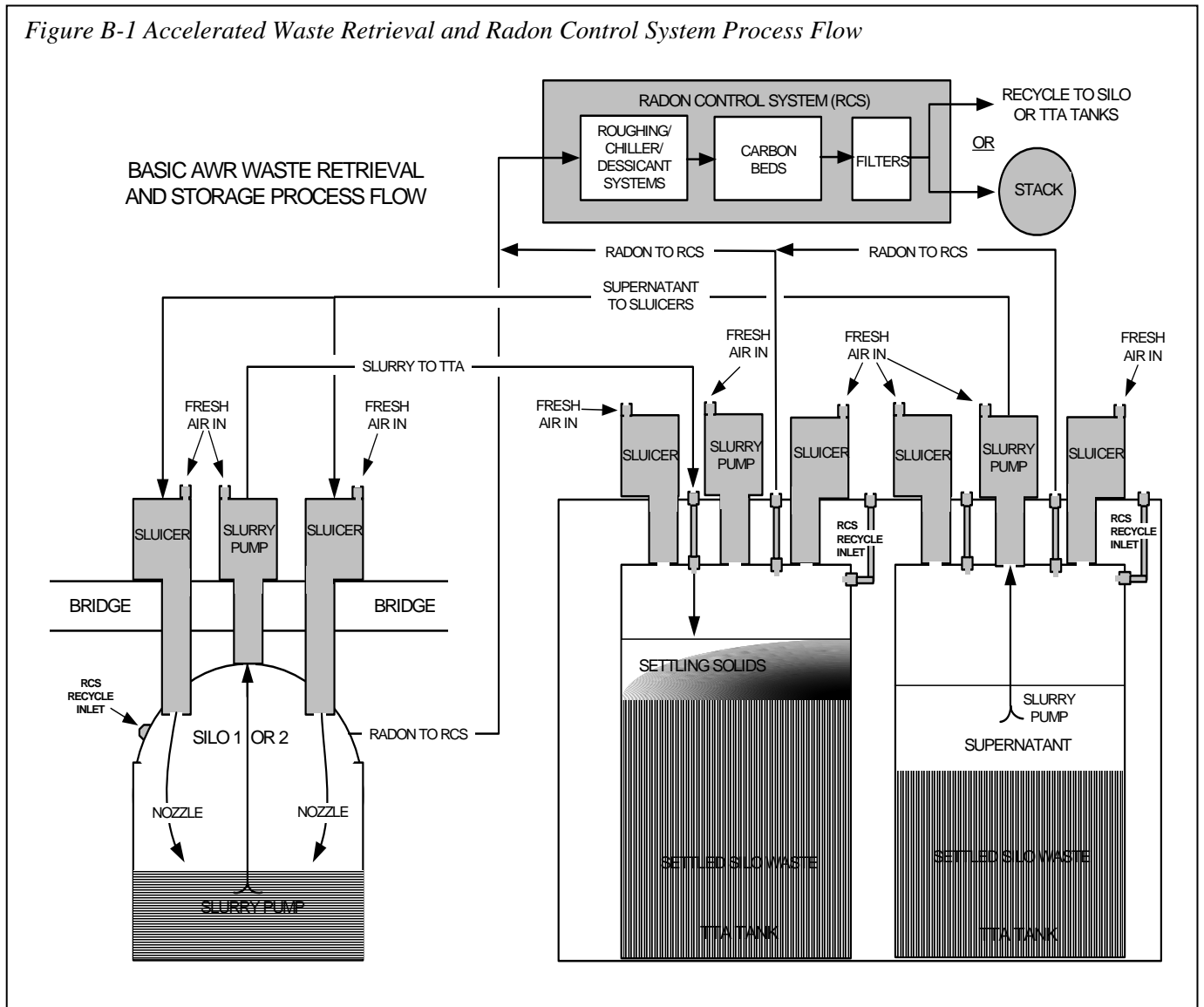

Figure B-2 Silos 1 and 2 Remediation Process

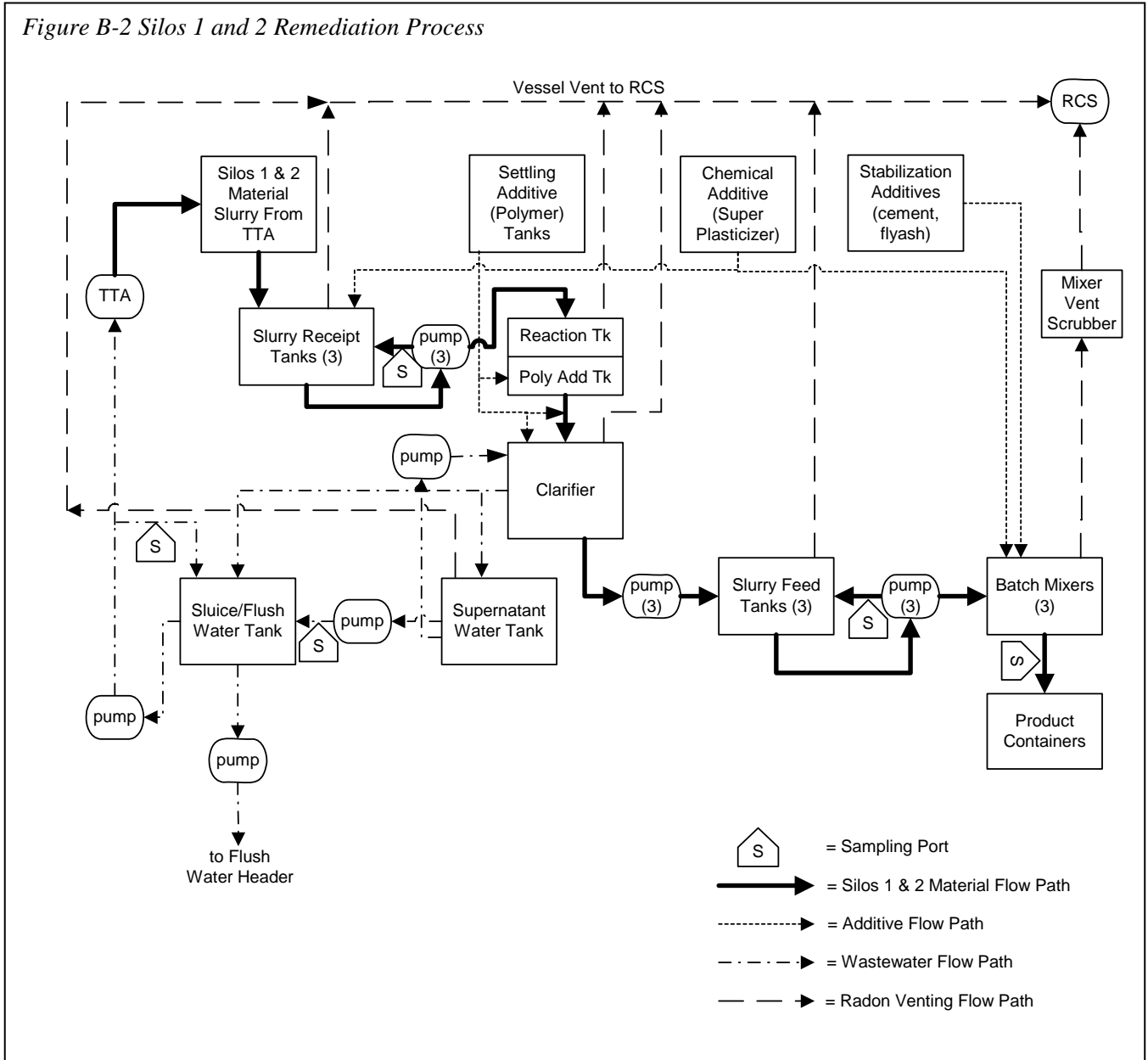

Figure B-3 Silos Wastewater Treatment Process

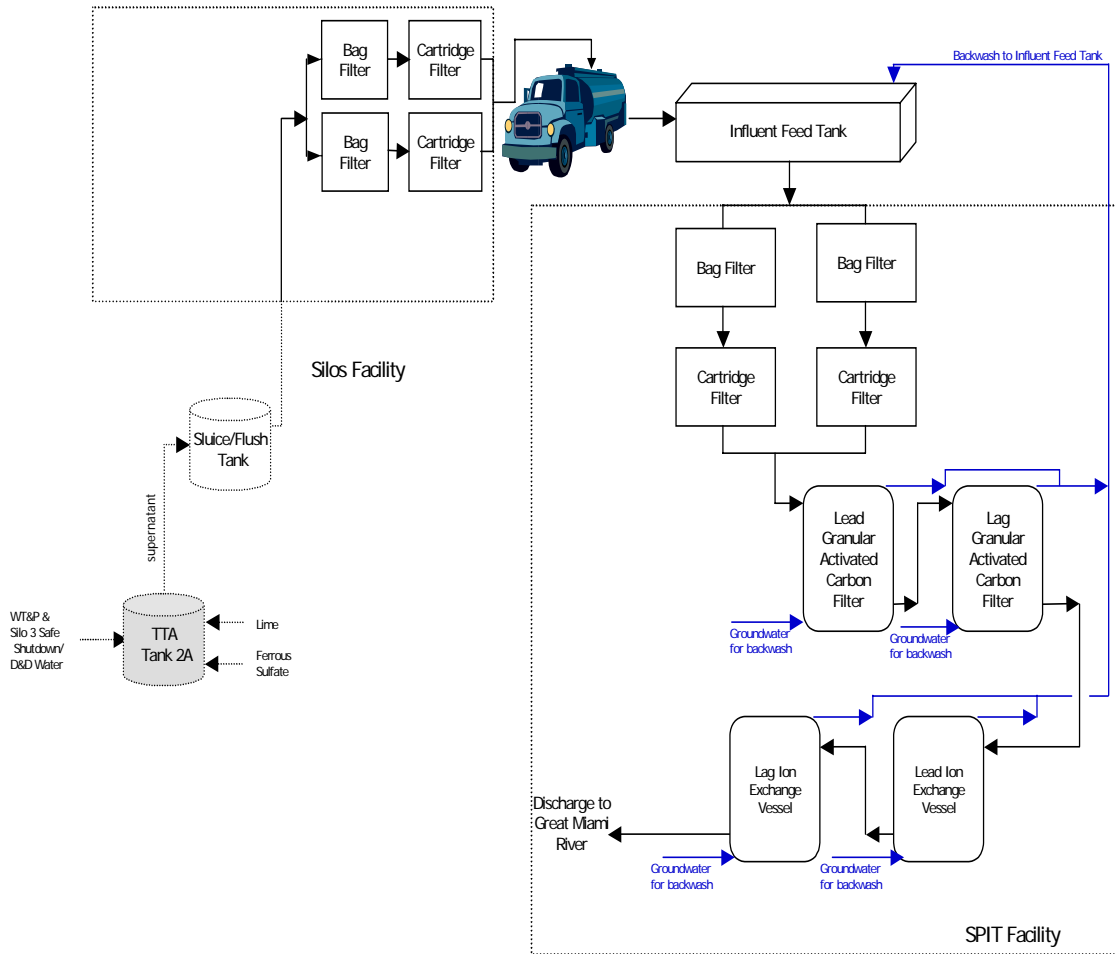
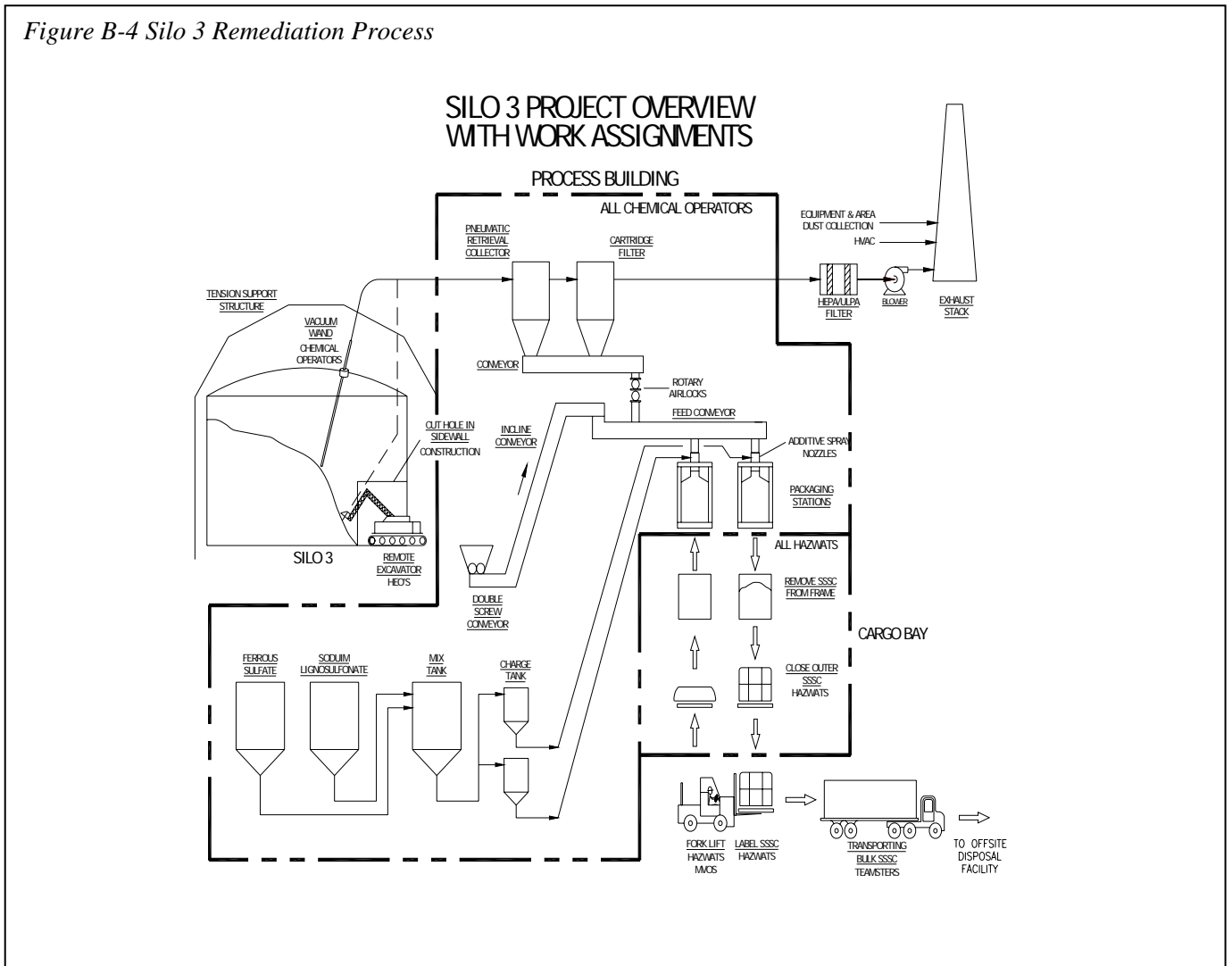

Figure B-4 Silo 3 Remediation Process



APPENDIX C – HWMU CLOSURES

There were no Hazardous Waste Management Units identified for Operable Unit 4.

APPENDIX D – REMOVAL ACTIONS

As discussed in Section 2.2, a removal action is a short-term cleanup action often completed prior to a more formal ROD process. There were three removal actions and one interim remedial measure associated with Operable Unit 4 (summarized below) that were conducted as an effort to minimize the release or threat of release of contaminants and to accelerate cleanup activities.

K-65 Silo Insulation Interim Remedial Measure

This interim measure was implemented in 1987 as part of the Compliance Plan for the 1986 FFCA, which required DOE to implement immediate measures to control radioactive emissions from the FMPC. Evaluation of the silos indicated that radon emissions were resulting from the pressure differential between the silo interior and the outside atmosphere caused by normal daily thermal cycling. The purpose of the K-65 Silo Insulation Action was to reduce the ongoing “breathing” of Silos 1 and 2 by insulating the domes from solar radiation and thereby minimizing thermal cycling. The interim measure consisted of:

- Construction and operation of a Radon Treatment System (RTS) to allow circulation of the Silos 1 and 2 headspaces through activated carbon to reduce radon concentrations in the headspaces during maintenance and sampling activities;
- Periodic operation of the RTS to reduce headspace radon concentrations, and thereby reduce direct radiation levels on the silo domes to acceptable levels during application of insulation; and
- Application of a layer of rigid polyurethane foam insulation to the exterior dome surfaces of Silos 1 and 2. The foam was 3 inches thick at the outer edge of the dome and 1.5 inches thick at the dome cap.

Removal Action No. 4 – K-65 Silos Removal Action

The K-65 Silos Removal Action was conducted to meet the terms of the 1991 ACA and the November 1991 Federal Facility Agreement (FFA) for Control and Abatement of Radon-222 Emissions between the DOE and the EPA. The purpose of the removal action was to mitigate the ongoing radon emissions from Silos 1 and 2 until final Operable Unit 4 remedial actions could be implemented. The Removal Action was designed to:

- Reduce the routine emissions of radon from the K-65 silos to the maximum extent practical within the context of the removal action.
- Decrease, mitigate, or otherwise control the radon gas inventory in the K-65 silos so that a failure of the dome(s) would not result in a release of significant quantities of radon gas, which would pose a threat to the public.
- Decrease, mitigate, or otherwise control the threat of K-65 residues released in significant quantities as a result of dome failure.

An application of a layer of bentonite covering the residues in Silos 1 and 2 was selected as the alternative for implementation of the K-65 Silos Removal Action. Between November 20 and November 28, 1991, approximately 670 cubic meters of slurried bentonite (25 percent dry bentonite and 75 percent water) was placed over the Silos 1 and 2 residues via a crane-supported remote distributor spray head inserted into the manways in the silo domes.

The Final Report for the K-65 Silos Removal Action [DOE 1994c] reported that headspace radon concentrations during the previous year (April 1993 through March 1994) had ranged from 315 pCi/L to 7,400,000 pCi/L, compared to pre-removal action concentrations in excess of 30,000,000 pCi/L. Silo headspace, onsite, and fence-line radon concentrations were measured on a continuous basis to track the effectiveness of the removal action, and were reported to the EPA, the Ohio EPA, and the public, until completion of the Operable Unit 4 Remedial Action.

K-65 Decant Sump Tank Removal Action (Removal Action No. 5)

This removal action was implemented to remove the water accumulated in the decant sump tank. The underground 9000-gallon tank was originally installed to receive decant water generated during slurry transfer of the K-65 residues into Silos 1 and 2, and leachate from the Silos 1 and 2 underdrain system. Since that time, water had accumulated in the tank, assumed to be from a combination of leachate from the underdrain system and infiltration of perched water.

In April 1991, an electric-powered submersible deep well pump was used to pump the accumulated water from the decant sump tank to a tank trailer. The water was then sampled and discharged to the site wastewater treatment system for disposition in accordance with the National Pollutant Discharge Elimination System (NPDES) permit. A total of approximately 8000 gallons of liquid was removed from the decant sump tank.

The removal action also specified periodic monitoring of the liquid level in the tank and removal of the liquid when it reached 80 percent of the tank's capacity. The tank was pumped out for a second time in late January and early February 1993, and every one to two years thereafter until Silos 1 and 2 waste retrieval was initiated in September 2004.

Silo 3 Expedited Removal Action (Removal Action No. 21)

The Silo 3 Expedited Removal Action was conducted in December 1991 after an inspection showed that the condition of the dust collector system on the dome of Silo 3, used during pneumatic transfer of the residues into the silo, had deteriorated significantly over the years. The removal action involved the removal of the dust collector and hopper assembly from the dome to eliminate the potential for release of the residual material contained in the dust collector hopper.

This action was accomplished by removing the dust collector and hopper system from the dome as a single unit and placing it directly into a sea/land container for disposal. All ancillary piping and equipment associated with the dust collector system was also removed from the dome and packaged for disposal.

Pre-Remedial Action Improvements and Controls

In addition to the above formal actions undertaken, several measures to protect the structural integrity of the Silos 1 and 2 structures and to mitigate radon emissions were conducted prior to initiating remedial actions. In 1964, an earthen embankment was built surrounding the walls of Silos 1 and 2 to provide relief from tensile stress that had developed within the walls, to provide protection from weather, reduce radon emissions, and increase shielding from penetrating radiation. Prior to constructing the berm, the decant system was disconnected from the sump tank, leaving the underdrain system connected. A 33-foot high 30-inch corrugated pipe was installed from the tank to the surface of the berm. In 1984, additional soil was added to reduce the slope of the berm in order to minimize erosion and facilitate grass cutting.

In response to structural evaluations conducted in 1985 identifying loss of the load-carrying capacity of the center portions of the Silo 1 and 2 domes, 30-foot diameter load-spreading dome covers were installed spanning the center portion of the domes in January 1986. The covers consisted of plywood sheeting and supported structural steel members from a steel skirt and covered with a weatherproof membrane.

APPENDIX E – LEGAL AGREEMENTS

The DOE has conducted operations at the Fernald Site under several legal agreements beginning with the 1986 FFCA. This includes the Consent Agreement and Amended Consent Agreement under CERCLA 121 and other agreements such as Ohio EPA Directors Findings and Orders, and Consent Decrees. This appendix, however, describes the legal agreements specific to Operable Unit 4, which consisted of a Federal Facility Agreement relative to radon emissions and one dispute resolution under the Amended Consent Agreement.

Federal Facility Agreement (FFA) for Control and Abatement of Radon-222 Emissions

Subpart Q of the National Emission Standards for Hazardous Air Pollutants (NESHAP) regulations, effective December 15, 1996, established a flux standard of 20pCi/m²/sec for emissions of radon-222 from sources at DOE facilities. The regulation defines a source as a building, structure or area at a DOE facility that is used for interim storage or disposal and contains radium in sufficient quantities to emit radon-222 in excess of 20pCi/m²/sec prior to remedial action. When the standard was promulgated, it was recognized that radon emissions from Silos 1 and 2, and potentially other sources at the site, would produce a flux in excess of 20 pCi/m²/sec, but as stated in the FFA, DOE and EPA “disagree as to the timeframe within which U.S. DOE must demonstrate compliance with Subpart Q at the FMPC.... The parties do not resolve that issue with this agreement.” The FFA further stated that “all schedules required for actions required by this agreement have been or will be established pursuant to the CERCLA Consent Agreement.” All actions required by the FFA have been completed. The manner in which the FFA is terminated is currently being negotiated with EPA and its status or disposition will be discussed in the Final Remedial Action Report for Operable Unit 4.

The FFA, which was approved November 14, 1991, required the following actions related to Operable Unit 4:

- Implementation of the K-65 Silos Removal Action (see Appendix D), in accordance with the schedule and other requirements established under the ACA.
- In accordance with the approved Removal Action Work Plan, provide ongoing monitoring and reporting of radon emissions to track the effectiveness of the bentonite and determine the need for any additional actions prior to the Operable Unit 4 remedial action.
- Estimate the radon flux from Silo 3 and determine the need for any actions prior to the Operable Unit 4 remedial action.
- After completion of the Operable Unit 4 Remedial action, demonstrate compliance with the NESHAP Subpart Q flux standard.

Agreement Resolving Dispute Concerning Denial of Request for Extension of Time for Certain Operable Unit 4 Milestones – July 1997

As was discussed in Section 2.5, technical difficulties were experienced during treatability testing to support the remedial design for the original vitrification remedy for Silos 1, 2, and 3 materials. These technical issues resulted in documented cost increases and schedule delays in the remedial design and remedial action process. In September 1996, DOE formally requested extension of enforceable milestones associated with implementing the Operable Unit 4 remedy. In October 1996, EPA denied DOE’s request for extension of the milestones. EPA and DOE then initiated the formal dispute resolution process under the ACA and began reevaluation of the technical path forward for remediation of the silos material. In November 1996, the DOE convened the Silos Project Independent Review Team (IRT) as a technical resource to assist the DOE in this reevaluation. The DOE, IRT, EPA, Ohio EPA and other stakeholders ultimately concluded that an alternate remedy should be considered for the Silo 3 material and that the treatment remedy for the Silo 1 and 2 materials should be reevaluated.

On July 22, 1997, the DOE and the EPA formally entered into the Agreement Resolving Dispute Concerning Denial of Request for Extension of Time for Certain Operable Unit 4 Milestones. The agreement stipulated that DOE would:

- Prepare an Explanation of Significant Differences (ESD) for documenting a revised treatment remedy for the Silo 3 material.
- Award contracts for proof of principle testing of potential treatment technologies for Silos 1 and 2 material
- Proceed with development of a supplemental Feasibility Study/Proposed Plan (FS/PP), incorporating the results of the proof of principle testing and subsequent ROD Amendment documenting a revised remedy for the Silos 1 and 2 material
- Implement the following five Supplemental Environmental Projects:
 - Establishment of a Conservation Area near the FEMP
 - Establish Research Grants for Ecological Restoration
 - Create a Wild Bird/ Wild Flower Habitat Area
 - Implement Railroad Track Recycling
 - Implement Structural Steel Debris Recycling.
- Pay a \$100,000 monetary penalty in accordance with the ACA

All actions required under this agreement have been completed.

APPENDIX F – REFERENCES

U.S. Department of Energy 1990a, "Removal Action 5, K-65 Decant Sump Tank Removal Action Work Plan," DOE, Oak Ridge Operations Office

U.S. Department of Energy 1990b, "Removal Action 4, Silos 1 and 2 (K-65) Silos Removal Action Work Plan," DOE, Oak Ridge Operations Office

U.S. Department of Energy 1991, DOE Letter DOE-523-92, Jack Craig to James Saric, U.S. EPA and Graham Mitchell, Ohio EPA, "Silo 3 Removal Action," dated December 19, 1991

U.S. Department of Energy 1993a "Remedial Investigation Report for Operable Unit 4", DOE, Fernald Area Office, Cincinnati, OH

U.S. Department of Energy 1994a "Feasibility Study for Operable Unit 4" DOE, Fernald Area Office, Cincinnati, OH

U.S. Department of Energy 1994b "Record of Decision for Operable Unit 4", DOE, Fernald Area Office, Cincinnati, OH

U.S. Department of Energy 1994c "Final Report for the Silos 1 and 2 (K-65) Removal Action," DOE, Fernald Area Office, Cincinnati, OH

U.S. Department of Energy 1995 "Work Plan for the Operable Unit 4 Remedial Design," DOE, Fernald Area Office, Cincinnati, OH

U.S. Department of Energy 1997 "Vitrification Pilot Plant Melter Incident Final Report," DOE, Fernald Area Office, Cincinnati, OH

Silos Project Independent Review Team (IRT) 1997, Silos Project Independent Review Team Final Report. Prepared for Fluor Fernald, Fernald, OH.

U.S. Department of Energy 1998a "Final Explanation of Significant Differences for Operable Unit 4 Silo 3 Remedial Action at the Fernald Environmental Management Project," DOE, Fernald Area Office, Cincinnati, OH

U.S. Department of Energy 1998b "Remedial Design Work Plan for Operable Unit 4 Silo 3 Project," DOE, Fernald Area Office, Cincinnati, OH

U.S. Department of Energy 2000a, "Record of Decision Amendment for Operable Unit 4 Silos 1 and 2 Remedial Actions," DOE, Fernald Area Office, Cincinnati, OH

U.S. Department of Energy 2000b, "Silo 3 Project Site Preparation Package," DOE, Fernald Area Office, Cincinnati, OH

U.S. Department of Energy 2000c, "Silo 3 Project Remedial Design Package," DOE, Fernald Area Office, Cincinnati, OH

U.S. Department of Energy 2000d, "Silos 1 and 2 Accelerated Waste Retrieval Project Site Preparation Package," DOE, Fernald Area Office, Cincinnati, OH

U.S. Department of Energy 2001a, “Draft Final Remedial Design Package for the Silos 1 and 2 Accelerated Waste Retrieval Project, Revision 1,” DOE, Fernald Area Office, Cincinnati, OH

U.S. Department of Energy 2001b, “Remedial Design Work Plan for Operable Unit 4 Silos 1 and 2 Project, Rev 2,” DOE, Fernald Area Office, Cincinnati, OH

U.S. Department of Energy 2002a, “Draft Final Remedial Design Package for the Silos 1 and 2 Accelerated Waste Retrieval Project, Revision 2,” DOE, Fernald Area Office, Cincinnati, OH

U.S. Department of Energy 2003a, “Record of Decision Amendment for Operable Unit 4 Silo 3 Remedial Action,” DOE, Fernald Area Office, Cincinnati, OH

U.S. Department of Energy 2003b, “Explanation of Significant Differences for Operable Unit 4 Silos 1 and 2 Remedial Actions,” DOE, Fernald Area Office, Cincinnati, OH

U.S. Department of Energy 2003c “Revised Proposed Plan for Operable Unit 4 Silo 3 Remedial Action,” DOE, Fernald Area Office, Cincinnati, OH

U.S. Department of Energy 2003d, “Silo 3 Project Remedial Design / Remedial Action Package,” DOE, Fernald Area Office, Cincinnati, OH

U.S. Department of Energy 2003e, “Response to Comments on Silos 1 and 2 Accelerated Waste Retrieval Project Remedial Design Package,” DOE, Fernald Area Office, Cincinnati, OH

U.S. Department of Energy 2003f, “Silos 1 and 2 Remediation Facility Remedial Design Package,” DOE, Fernald Area Office, Cincinnati, OH

U.S. Department of Energy, 2005a, “Development of CERCLA Remedial Action Closeout Reports for the Fernald Closure Project, Fact Sheet,” Fernald Closure Project, Fernald Area Office, Fernald, OH

U.S. Department of Energy 2005b, “Explanation of Significant Differences for Operable Unit 4 Remedial Actions,” DOE, Fernald Area Office, Cincinnati, OH

U.S. Department of Energy 2005c, “Silos 1 and 2 Project Transportation and Disposal Plan,” DOE, Fernald Area Office, Cincinnati, OH

U.S. Department of Energy 2005d, “Silo 3 Project Transportation and Disposal Plan,” DOE, Fernald Area Office, Cincinnati, OH

Waste Control Specialists, 2005, Waste Profile No. WP-019387

Envirocare, 2005, Radioactive Waste Profile Record, EC-0230, Rev.4

U.S. Department of Energy, 2006, “Comprehensive Legacy Management and Institutional Controls Plan,” Draft Final, DOE, Fernald Area Office, Cincinnati, OH

APPENDIX G – WASTE UNIT PHOTOS

Figure G-1 Accelerated Waste Retrieval Temporary Tank Area Construction (circa Spring 2002)

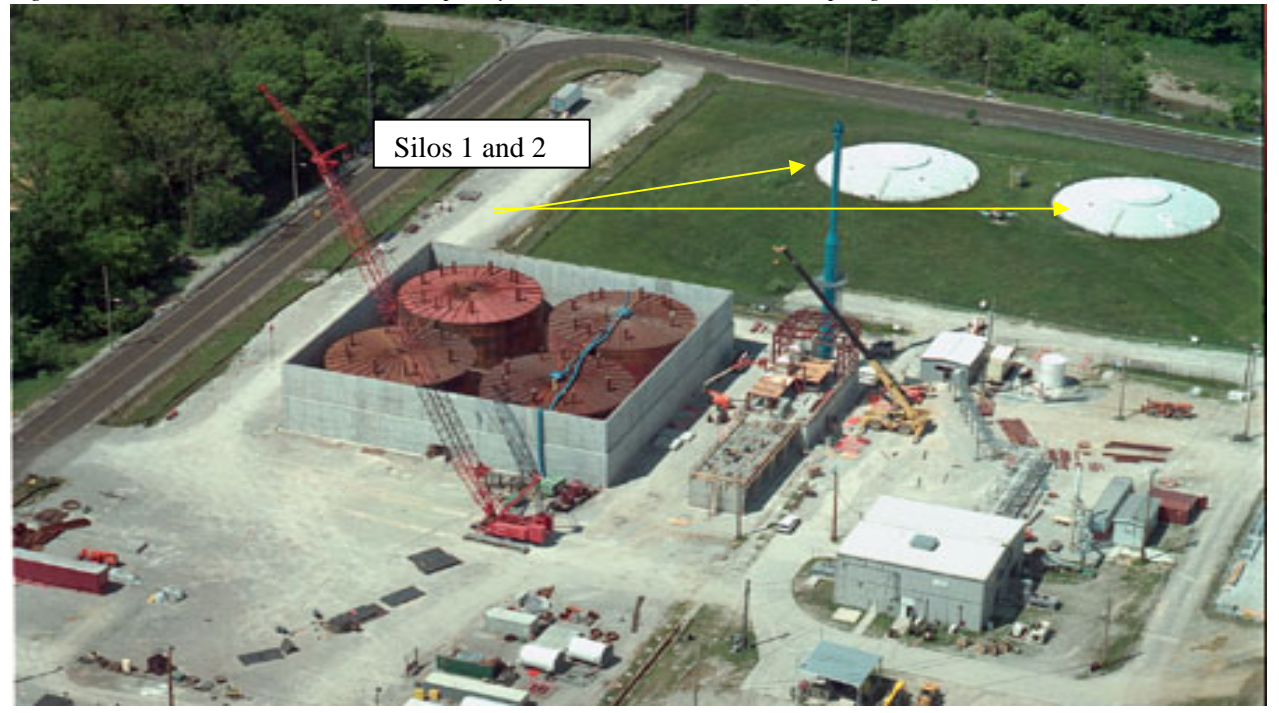

Figure G-2 Operable Unit 4 Remediation Facilities

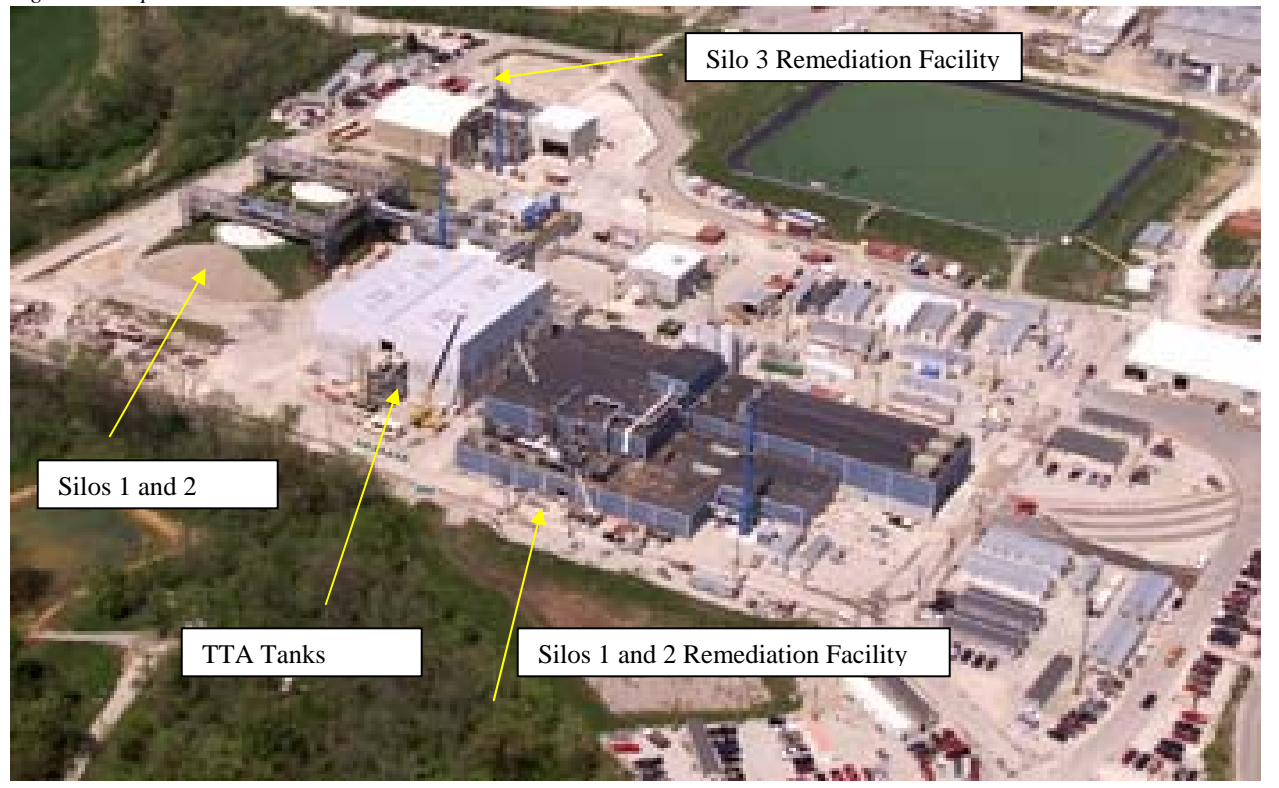

Figure G-3 Silo 3 Remediation Facility



Figure G-4 Silo 3 Soft Sided Container Loaded into Shipping Container



Figure G-5 Silos 1 and 2 Containers Ready for Shipping



Figure G-6 Silo 3

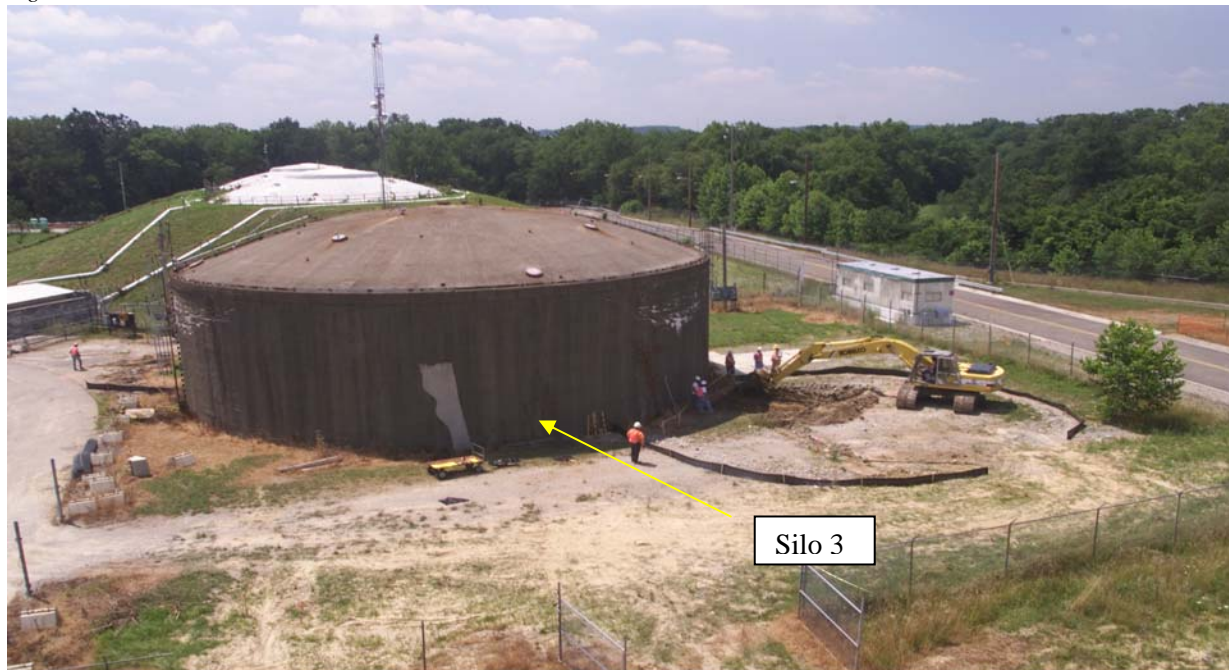

APPENDIX H – LIST OF ACRONYMS

ACA	Amended Consent Agreement
AEC	Atomic Energy Commission
ALARA	As Low As Reasonably Achievable
AWR	Accelerated Waste Retrieval
CAWWT	Converted Advanced Wastewater Treatment
CERCLA	Comprehensive Environmental Response, Compensation, and Liability Act
D&D	Decontamination & Dismantlement
DF&O	Director’s Findings & Orders
DOE	U.S. Department of Energy
DOT	U.S. Department of Transportation
EPA	U.S. Environmental Protection Agency
ESD	Explanation of Significant Differences
FCP	Fernald Closure Project
FEMP	Fernald Environmental Management Project
FERMCO	Fernald Environmental Restoration Management Company
FFA	Federal Facilities Agreement
FFCA	Federal Facilities Compliance Agreement
FMPC	Feed Materials Production Center
FS/PP	Feasibility Study/Proposed Plan
HEPA	High Efficiency Particulate Air Filter
HWMU	Hazardous Waste Management Unit
ILCR	Incremental Lifetime Cancer Risk
IP-2	Industrial Packaging – Type 2
ISA	Interim Storage Area
IRT	Silos Project Independent Review Team
LMICP	Legacy Management and Institutional Controls Plan
NCP	National Oil and Hazardous Substances Pollution Contingency Plan
NESHAP	National Emission Standards for Hazardous Air Pollutants
NLO	National Lead of Ohio
NPDES	National Pollutant Discharge Elimination System

NPL	National Priorities List
OFFO	Office of Federal Facilities Oversight (Ohio EPA)
Ohio EPA	Ohio Environmental Protection Agency
OSDF	On-site Disposal Facility
OSWER	Office of Solid Waste and Emergency Response (EPA)
pCi/g	picocuries/gram
pCi/L	picocuries/liter
PVC	Polyvinyl chloride
QC	Quality Control
RCS	Radon Control System
RCRA	Resource Conservation and Recovery Act
RI/FS	Remedial Investigation/Feasibility Study
ROD	Record of Decision
RTS	Radon Treatment System
SARA	Superfund Amendments and Reauthorization Act
SCQ	Site-wide CERCLA Quality Assurance Project Plan
SPIT	South Plume Interim Treatment
SP/UU	Site Preparation/Underground Utilities
SWRS	Silos Waste Retrieval System
TCLP	Toxicity Characteristic Leaching Procedure
TTA	Transfer Tank Area
TTWRS	Transfer Tank Waste Retrieval System
VitPP	Vitrification Pilot Plant
VOC	Volatile Organic Compound
WAC	Waste Acceptance Criteria
WCS	Waste Control Specialists
WEMCO	Westinghouse Environmental Management Company of Ohio
WMCO	Westinghouse Materials Company of Ohio

APPENDIX I – SIGNATURE PAGE

I certify that the remedial actions as described within this report have been completed.

Johnny W. Reising, Director
United States Department of Energy
Fernald Closure Project

