

U.S. Patent Application No. 10/926,405  
Filed 26 Aug 2004 (DHHS Reference  
No. E-096-2004/0-US-01)

*Licensing Contact:* Michael Shmilovich;  
301/435-5019;  
*shmilovm@mail.nih.gov.*

Available for licensing and commercial distribution are optical cells that are spectroscopically, thermally and mechanically stable and can be used for spectroscopic measurement in transmission, reflection, transmission-reflection, emission, or scattering modes without modification of standard spectrometers. The cell handles liquid samples and biological or solid samples equilibrated with bathing fluid which does not interfere with the light beam, allows liquid sample or bathing fluid to be exchanged without cell reassembly, requires only a small amount of sample (down to 0.1 $\mu$ l), allows for different sample gaps (0.2-1000 $\mu$ m) to be easily and inexpensively set, and allows spectral measurements to be taken over wavelengths ranging at least from the mid-infrared to the vacuum ultraviolet. The inventive cell and methods allows sensitive and reproducible monitoring spectra and their changes (down to at least 10<sup>-4</sup> absorbance units) caused by changes in temperature or in composition of bathing fluid or by fast kinetic processes.

This research is described, in part, in Mertz E.L., Leikin S. "Interactions of Inorganic Phosphate and Sulfate Anions with Collagen", *Biochemistry*, in press.

#### Device for Sequential Protein Transfer From a Gel

Jozsef Antal, Zsuzsanna Buzas, Andreas Chrambach (NICHD)

DHHS Reference No. E-346-2003/0-US-01 filed 09 July 2004

*Licensing Contact:* Michael Shmilovich;  
301/435-5019;  
*shmilovm@mail.nih.gov.*

Available for licensing and commercialization is a device for sequentially eluting proteins and peptides. The device comprises a separation medium having an outlet, and a collector having a first receptacle and second receptacle that can be sequentially brought into contact with the outlet of the separation medium by translating (rotating) the first receptacle and the second receptacle in relation to the outlet of the separation medium. The invention is adaptable to capillary electrophoresis as well. Multiple sequential protein transfer from SDS-PAGE gel to a mass spectrometer is made possible. Separated protein bands sequentially electrophorese into low melting agarose plugs distributed along the surface of a plastic drum. The

effective electroelution of a protein from a gel band to an agarose filled slot. The drum is rotated to receive each band individually. Migrating SDS linearized proteins are electrophoresed into the receptacle slot drum. The drum is rolled until each protein of interest is separated. Agarose plugs are lifted from the drum slots; enzymatically dissolved, and loaded directly onto a MALDI spectrometer. Between two agarose layers, gel free collection chambers can be formed inside the drum providing solution phase fraction collection.

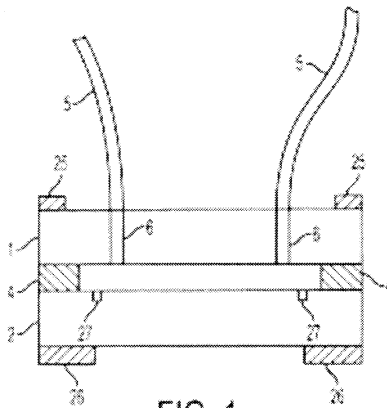

This research is described in: Buzas Z, Antal J, Gilligan JJ, Backlund PS, Yergey AL, Chrambach A. An electroelution apparatus for sequential transfer of sodium dodecyl sulfate-proteins into agarose and mass spectrometric identification of Li-Na-dodecyl sulfate-proteins from solubilized agarose. *Electrophoresis*. 2004 Apr;25(7-8):966-9.

#### Simultaneous HDL/LDL/Total Lipoprotein Single Tube Homogeneous Assay

Alan T. Remaley, Maureen Sampson, Gyorgy Csako (CC)

DHHS Reference No. E-090-1999: U.S. Patent App. 09/980,751 Filed 01 Nov 2001; European Patent App. Ser. No. 00939404.0 Filed 26 May 2000; Canadian Patent. App. 2375210 Filed 26 May 2000; Australian Pat. App. 54493/00 filed 26 May 2000; Japanese Patent App. 2001-500866 filed 26 May 2000

*Licensing Contact:* Michael Shmilovich;  
301/435-5019;  
*shmilovm@mail.nih.gov.*

Available for licensing is an invention in which a single tube assay is used for determining high-density lipoprotein HDL-cholesterol (HDL-C), low density lipoprotein (LDL-C) and total cholesterol (total-C), from a single serum sample. This assay is an efficient tool for use in determining patient risk factors for heart disease. Previously,

multiple costly tests were performed in order to determine low-density lipoprotein LDL-C and HDL-C by measuring total-C, total triglyceride, and HDL-C. That method of testing had limitations and was complex. Using this methodology, the homogeneous assay for HDL-C does not require physically separating HDL. The new assay developed is efficient, less costly, and compares favorably to current assays for HDL-C, total cholesterol, and triglyceride. This technology may also be used to simplify the procedure for the point of care testing of hyperlipidemia.

Dated: September 22, 2004.

**Steven M. Ferguson,**

*Director, Division of Technology Development and Transfer, Office of Technology Transfer, National Institutes of Health.*

[FR Doc. 04-22151 Filed 10-1-04; 8:45 am]

BILLING CODE 4140-01-P

## DEPARTMENT OF HEALTH AND HUMAN SERVICES

### Substance Abuse and Mental Health Services Administration

#### Center for Substance Abuse Prevention Correction of Meeting Notice

Pursuant to Pub. L. 92-463, notice is hereby given of a correction of a notice of a meeting of the Substance Abuse Prevention (CSAP) National Advisory Council to be held in October 2004.

Public notice was given in the **Federal Register** on September 27, 2004 (Volume 69, Number 186, page 57711) that the CSAP National Advisory Council would be meeting on October 5 and 6, 2004 at The Times Building, One Times Square, Third Floor, New York, New York. The place for this meeting has subsequently changed to The Renaissance New York Hotel Times Square, Two Times Square, 714 Seventh Avenue at W. 48th Street, New York, New York. The agenda and date of the meeting and contact for additional information remain as announced.

Dated: September 30, 2004.

**Toian Vaughn,**

*SAMHSA Committee Management Officer, Substance Abuse and Mental Health Services Administration.*

[FR Doc. 04-22339 Filed 10-1-04; 8:45 am]

BILLING CODE 4162-20-P