

BNL 34518  
Fourteenth Edition  
Informal Report

AGS Experiments - 1995 ! 1996 ! 1997

J.C. Depken and P. Lo Presti

December 1997

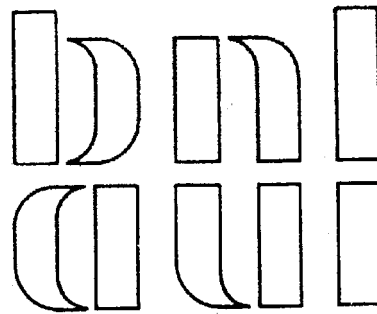

AGS Department  
Experimental Planning and Support Division

Brookhaven National Laboratory  
Associated Universities, Inc.  
Upton, New York 11973-5000  
United States of America

## DISCLAIMER

This report was prepared as an account of work sponsored by an agency of the United States Government. Neither the United States Government nor any agency thereof, nor any of their employees, nor any of their contractors, subcontractors, or their employees, makes any warranty, express or implied, or assumes any legal liability or responsibility for the accuracy, completeness or usefulness of any information, apparatus, product, or process disclosed, or represents that its use would not infringe privately owned rights. Reference herein to any specific commercial product, process or service by trade name, trademark, manufacturer, or otherwise, does not necessarily constitute or imply its endorsement, recommendation, or favoring by the United States Government or any agency, contractor, or subcontractor thereof. The views and opinions of authors expressed herein do not necessarily state or reflect those of the United States Government or any agency, contractor or subcontractor thereof.

## AGS Experiments - 1995, 1996 and 1997

This report contains:

Page:

I	T	FY 1995 AGS Schedule as Run
II	T	FY 1996 AGS Schedule as Run
III	T	FY 1997 AGS Schedule as Run
IV	T	FY 1998-1999 A GS Schedule (proposed)
V	T	AGS Beams 1997
VI	T	AGS Experimental Area FY 1995 Physics Program
VII	T	AGS Experimental Area FY 1996 Physics Program
VIII	T	AGS Experimental Area FY 1997 Physics Program
IX	T	AGS Experimental Area FY 1998-1999 Physics Program (proposed)
i	T	A listing of experiments by number
105	T	Two-page summaries of each experiment, in order by number
147	T	Listing of publications of AGS experiments

This is the *fourteenth*. Please forward suggestions and changes for future editions to:

Division Head, EP&S Division  
Brookhaven National Laboratory  
Building 911B  
Upton, New York 11973-5000 U.S.A.

The CUTOFF DATE FOR APPROVED EXPERIMENTS INCLUDED IN THIS EDITION IS DECEMBER  
1997.

## LIST OF EXPERIMENTS

<i>Exp.</i>	<i>Collaboration/Spokesmen</i>	<i>Page</i>
787	<b>A Study of the Decay <math>K^0 \rightarrow 6 B^0 \pi^-</math></b> BNL/Fukui/KEK/Osaka/Princeton/TRIUMF/Alberta <i>Bryman, Littenberg, and Smith</i>	1
813	<b>Search for a Strangeness -2 Dibaryon</b> Carnegie-Mellon/Alberta/Birmingham/BNL/Freiburg/IUCF/Kyoto/Kyoto- Sangyo/LAMPF/Manitoba/New Mexico/TRIUMF/Vassar/Yale <i>Franklin and Barnes</i>	3
821	<b>A New Precision Measurement of the Muon <math>g-2</math> at the Level of 0.35 PPM</b> Boston/BNL/Budker Institute/Cornell/Fairfield/Heidelberg/Illinois/LBL/ Max Planck Inst/Minnesota/KEK/Riken/Tokyo/Yale <i>Hughes, Morse, and Roberts</i>	5
850	<b>EVA, A Solenoidal Detector for Large Angle Exclusive Reactions. Experiment 850- Determining Color Transparency to 22 GeV/c</b> Auckland/BNL/JINR/Mt. Holyoke/Penn St/Massachusetts -Dartmouth/Tel-Aviv <i>Carroll and Heppelmann</i>	7
852	<b>Search for Mesons with Unusual Quantum Numbers</b> BNL/Indiana/Massachusetts-Dartmouth/Moscow St/Northwestern/ Notre Dame/IHEP-Protvino/RPI <i>Cason and Chung</i>	9
856	<b>Exploration of the Biomedical Potential of Antiprotons</b> BNL/Case Western Reserve/Harvard Cyclotron Lab/Loma Linda/Massachusetts/ Syracuse/SUNY Health Science Center <i>Kalogeropoulos</i>	11
864	<b>Production of Rare Composite Objects in Relativistic Heavy Ion Collisions</b> BNL/ Iowa St/Ames Lab/MIT/Penn St/Purdue/Bari/Massachusetts/Vanderbilt/ Wayne St/Yale/UCLA <i>Sandweiss</i>	13
865	<b>Proposal to Perform an Improved Search for the Decay <math>K^+ \rightarrow 6 B^+ \mu^+ e^-</math></b> BNL/Bern/Connecticut/Hampton/INR-Moscow/New Mexico/Paul Scherrer Inst/Basel/Pittsburgh/Tbilisi St/Yale/Zurich <i>Zeller</i>	15

<i>Exp.</i>	<i>Collaboration/Spokesmen</i>	<i>Page</i>
<b>866</b>	<b>Studies of Particle Production at High Baryon Density Using the Au Beam</b> BNL/Columbia/INS-Tokyo/Kyoto/LLL/Maryland/MIT/NYU/UC-Space Sciences Lab/UC-Riverside/Tokyo/Tsukuba/Yonsei <i>Chasman, Hamagaki, and Steadman</i>	<b>17</b>
<b>868</b>	<b>Interactions of 10.6 GeV/nucleon <math>^{197}\text{Au}</math> Nuclei in Nuclear Emulsions</b> Minnesota/Louisiana St/INP-Krakow/ITEP-Moscow <i>Waddington</i>	<b>19</b>
<b>869</b>	<b>Measurement of Fragment Yields for 14 GeV/nucleon Au + X Collisions</b> Minnesota/Washington/Caltech <i>Waddington</i>	<b>21</b>
<b>871</b>	<b>A New Search for Very Rare <math>K_L</math> Decays</b> UC-Irvine/Richmond/Stanford/Texas-Austin/William and Mary <i>Kane, Molzon, Ritchie and Wojcicki</i>	<b>23</b>
<b>877</b>	<b>Study of Relativistic Nuclear Collisions with Heavy Beams Using the E814 4B Calorimetry and Modified Forward Spectrometer</b> BNL/GSI-Darmstadt/Idaho Nat. Eng. Lab./McGill/Pittsburgh/São Paulo/ SUNY-Stony Brook/Wayne St <i>Braun-Munzinger</i>	<b>25</b>
<b>880</b>	<b>The Effects of a Partial Siberian Snake on Polarization at the AGS</b> IUCF/BNL/ANL/TRIUMF/Fermilab/KEK/IHEP-Serpukhov/Riken <i>Lee and Roser</i>	<b>27</b>
<b>885</b>	<b>Experiment to Detect <math>77</math> Hypernuclei</b> BNL/CMU/Freiburg/KEK/Kyoto/Kyoto-Sangyo/LANL/Manitoba/ New Mexico/Rutgers/TRIUMF <i>May, Franklin, and Davis</i>	<b>29</b>
<b>890</b>	<b>A New Test of Charged Symmetry in Eta Production on Deuterium</b> UCLA/BNL/LANL/Forschungszentrum Jülich/Ruder Boskovic Inst/ George Washington/PNPI/JINR-Dubna/Abilene Christian <i>Nefkens, Chrien and Peng</i>	<b>31</b>
<b>891</b>	<b>A Search for Quark Matter (QGP) and Other New Phenomena Utilizing Au-Au Collisions at the AGS</b> BNL/City College of New York/UC-Berkeley/Rice <i>Platner</i>	<b>33</b>
<b>892</b>	<b>Capture from Pair Production</b> Lawrence Berkeley Laboratory <i>Gould</i>	<b>35</b>

<i>Exp.</i>	<i>Collaboration/Spokesmen</i>	<i>Page</i>
893	<b>Temperature/Zenith Angle Calibration of Polycarbonate Tract Detectors</b> Dublin Institute for Advanced Studies <i>Thompson</i>	37
895	<b>Exclusive Study of Nuclear Collisions at the AGS</b> LBL//UC-Davis/Kent St/SUNY-Stony Brook/Ohio St/Purdue/CMU/ BNL/Columbia/Harbin Inst/Auckland <i>Rai</i>	39
896	<b>A Proposal to the BNL AGS: To Search for a Short-Lived <math>H_0</math> Dibaryon, Short-Lived Strange Matter, and to Investigate Hyperon Production in 11.6 A GeV/c AuAu Collision</b> SSL/BNL/UCLA/Carnegie-Mellon/Catania/CERN/Johns Hopkins/LBL/ Michigan/NASA-Goddard Space Flight Center/Ohio St/Texas-Austin/ Rice/Wayne St/Yale <i>Crawford and Hallman</i>	41
898	<b>Radiobiology and Biophysics with High Energy Heavy Ions</b> Colorado St/BNL/Jet Propulsion Laboratory/LBL/LANL/NASA-Johnson Space Ctr/MD/MD. School of Medicine/Georgetown Med. Ctr/UC/columbia/ Pacific NWNL/Bemidji <i>Miller/Kronenberg/Nelson</i>	43
900	<b>Energy Dissipation and Multifragmentation in H+A Reactions Between 2 &amp; 24 GeV/c</b> Indiana/Simon Fraser/Maryland/Texas A&M/BNL/LANL/ANL/Warsaw <i>Kwiatkowski and Viola</i>	45
903	<b>A Study of Domain Wall Pinning in Irradiated Samples of <math>ND_2Fe_{14}B</math></b> BNL/Ames Laboratory <i>Snead and Finnemore</i>	47
904	<b>A Study of Columnar Pinning Centers in High <math>T_C</math> Superconductor</b> Houston/Texas Southern/IUCF <i>Weinstein</i>	49
905	<b>Search for a E Hypernuclear Bound State in <math>^4He (K^-, B^{\pm})</math> Reactions</b> BNL/G. Washington/INS-Tokyo/Tokyo/Houston/North Carolina A&T/Hampton/North Carolina/Zagreb <i>Nagae</i>	51
906	<b>Experiment to Detect Double-7 Hypernuclei by Observing Characteristic B-Mesonic Decays</b> INS-Tokyo/BNL/Carnegie-Mellon/Gifu/Freiburg/INR-Russia/Kyoto/Kyoto- Sangyo/NC A&T/Osaka/Temple/New Mexico <i>Fukuda and Chrien</i>	53

<i>Exp.</i>	<i>Collaboration/Spokesmen</i>	<i>Page</i>
907	<b>Investigation of Light Hypernuclei Using the <math>(K_{STOP}^{\&amp;}BE)</math> Reaction</b> Arizona St/BNL/UCLA/CMU/CEBAF/Colorado/G. Washington/Houston/ Kentucky/ LANL/Louisiana Tech/Maryland/Minnesota/North Carolina A&T/R. Boskovic Inst/Texas-Austin/Tohoku/Zagreb <i>Hungerford and Peng</i>	55
909	<b>ETA Production and Threshold in the Reactions <math>B^p 6 On</math> and <math>K^p 6 7 O</math></b> G. Washington/UCLA/BNL/Abilene Christian/R. Boskovic Inst/JINR-Dubna/ PNPI-Gatchina <i>Briscoe and Tippens</i>	57
910	<b>A Facility to Study Proton-Nucleus and Heavy Ion Collisions Using a Large-Acceptance Detector with Particle Identification Capabilities</b> BNL/Columbia/Florida St/Kent St/LBL/LLNL/SUNY-Stony Brook/ Tennessee/Tsukuba/Yonsei <i>Cole</i>	59
913	<b>Baryon Spectroscopy with the Crystal Ball</b> Abilene Christian /ANL/Arizon State U/BNL/UCLA/G. Washington/ Kent St/ PNPI-Gatchina/R. Boskovic Inst/Colo/Karlsruhe/Regina/Valparaiso. <i>Sadler and Tippens</i>	61
914	<b>Neutral Hyperon Spectroscopy</b> Abilene Christian /ANL/Arizon State U/BNL/UCLA/G. Washington/ Kent St/ PNPI-Gatchina/R. Boskovic Inst/Colo/Karlsruhe/Regina/Valparaiso <i>Nefkens, Kycia, and Kruglov</i>	63
915	<b>Proposal for 11.4 GeV Au Exposure at the AGS-The Trek Collaboration</b> UC-Berkeley/Space Research Institute (IKI)-Moscow <i>Westphal</i>	65
916	<b>Study of Projectile Fragmentation for <math>^{197}Au</math> Ions at <math>\sim 4A</math> GeV in Various Targets</b> UC-Berkeley <i>He</i>	67
917	<b>Studies of High Density Baryon Matter Using Rare Probes</b> ANL/BNL/UC-Riverside/Columbia (Nevis Lab)/Maryland/MIT/Yonsei Illinois/Rochester <i>Seto and Mignerey</i>	69

<i>Exp.</i>	<i>Collaboration/Spokesmen</i>	<i>Page</i>
919	<b>A Study of the Genetic and Epigenetic Effects Produced by High Energy Heavy Ions</b> BNL/LBNL/Colorado St/USAF Armstrong Lab/Maryland-Baltimore County/ Maryland-Baltimore/Georgetown U. Medical Center/Loma Linda/LANL/ NASA-Johnson Space Ctr/UC/Columbia/Pacific NWNL/Washington St/ Case Western Reserve/NIRS-Japan/Texas/Alabama Agr. & Mech. <i>Vazquez</i>	71
920	<b>Lens Test for Proton Radiography</b> Los Alamos National Laboratory <i>Zumbro</i>	73
922	<b>Radiation Testing of NASA's Global Positioning System and Inertial Navigation Sensor (GPS/INS)</b> National Aeronautics and Space Administration <i>Culpepper</i>	75
923	<b>Search for T Violating Muon Polarization in <math>K^0 \rightarrow \mu^+ \mu^- B^0</math> Decay</b> BNL/INR-Moscow/Louisiana Tech/Yale <i>Adair, Diwan and Ma</i>	77
924	<b>Study of the <math>\Sigma(2220)</math> in <math>\bar{p} p</math> neutral final states using the Crystal Ball in the AGS D6 line</b> Boston/BNL/Carnegie-Mellon/Colorado/Connecticut/George Washington/ Illinois at Urbana-Champaign/Karlsruhe/Kent St/Maryland/Northwestern/ Petersburg Nuclear Physics Inst/Regina/UCLA/Valparaiso/William and Mary <i>Hertzog</i>	79
925	<b>Asymmetries in Inclusive Pion Production at Large <math>X_F = (0.5 \text{ to } 0.8)</math> and <math>P_T \leq 0.8 \text{ GeV}/c</math> with a Polarized Beam for a RHIC Polarimeter</b> ANL/BNL/IHEP- Protvino/ITEP- Moscow/Indiana/UCLA/ Iowa/RIKEN/Tokyo <i>Makdisi and Yokosawa</i>	81
926	<b>Measurement of <math>K_L^0 \rightarrow B^0 \pi^0</math></b> BNL/INR- Moscow/Kyoto/New Mexico/Thomas Jefferson National Accelerator Facility/TRIUMF/Yale/U.British Columbia/VPI <i>Bryman, Littenberg and Zeller</i>	83
929	<b>Spin-orbit splitting of single <math>7</math> state studied by the <math>^{13}\text{C}(K^-, B^-) Q</math> reaction</b> Osaka U./Tokyo/Tokyo-INS/Tohoku/ KEK/BNL/Houston/N.C. A&T/ Hampton/Manitoba <i>Kishimoto</i>	85



<i>Exp.</i>	<i>Collaboration/Spokesmen</i>	<i>Page</i>
930	<b>High-Resolution ( Spectroscopy of Hypernuclei using Large-Acceptance Germanium Detector</b> Tokyo/Osaka/KEK/Tohoku/BNL/North Carolina A&T/Hampton <i>Tamura</i>	87
931	<b>Study of the ) I=½ Rule n the Weak Decay of S-Shell Hypernuclei</b> Ariz/BNL/UCLA/Carnegie-Mellon/CEBAF/Colo/G. Wash/ Houston/Kentucky/LANL/La. Tech. /Maryland/Minnesota/NCA&T/ R. Boskovic Inst/Tex-Austin/Tohoku U/U.Zagreb <i>Dehnhard, Hungerford, Zeps</i>	89
932	<b>Study of RF Bunching Techniques</b> ANL/Fermi/BNL/KEK <i>Norem</i>	91
933	<b>Proton Radiography</b> LANL/LLNL/Bechtal <i>Morris and Hartouni</i>	93
934	<b>Proposal for Brookhaven Calibration of Detectors for Use on ACCESS</b> Washington Univ. in St. Louis/Caltech/Minnesota/Goddard Space Flight Center/Penn St <i>Binns</i>	95
935	<b>A Decay Search for a Light Gluino Bound State in the B5 Line</b> UC-Irvine/William and Mary/RPI/Richmond <i>Kuang</i>	97
936	<b>Search for T-Violation in the <math>K^0 \rightarrow B^0 \mu^+ \nu</math> Decay Using Stopped Kaons</b> KEK/SUT/Tsukuba/British Columbia and TRIUMF/Saskatchewan/ Montreal/VPI <i>Imazato</i>	99
937	<b>A Study of the Occurrence of Radiation-Induced Soft Error Upsets (SEU)</b> Colorado <i>Peterson</i>	101
938	<b>Spallation Neutron Target Studies at the AGS</b> ANL/BNL/Jülich/KEK/JARI/LANL/ORNL/PSI <i>Bauer, Haines, Hastings, Watanabe</i>	103
939	<b>Experiments for the DOE Accelerator Production of Tritium (APT) Project</b> BNL/LLNL/LANL/DOE/Bechtel Nevada/CEA/LNS-CNRS <i>King and Hanson</i>	105

<i>Exp.</i>	<i>Collaboration/Spokesmen</i>	<i>Page</i>
<b>940</b>	<b>Search for <math>\mu N6e^-N</math> with Sensitivity Below <math>10^{-16}</math></b> UC-Irvine/Houston/Inst.Nuclear Research/NYU/Pennsylvania/Purdue <i>Molzon</i>	<b>107</b>
<b>941</b>	<b>Study of Charged and Neutral Leading Particles in p+A Collisions at the BNL-AGS</b> Columbia/Iowa/MIT/Mass/Purdue/UCLA/Vanderbilt/Wayne State/ Yale <i>Huang and Majka</i>	<b>109</b>

**S***ummaries*

*of*

**E***xperiments*

# EXPERIMENT 787

Home Page • <http://www.phy.bnl.gov/e787/e787.html>

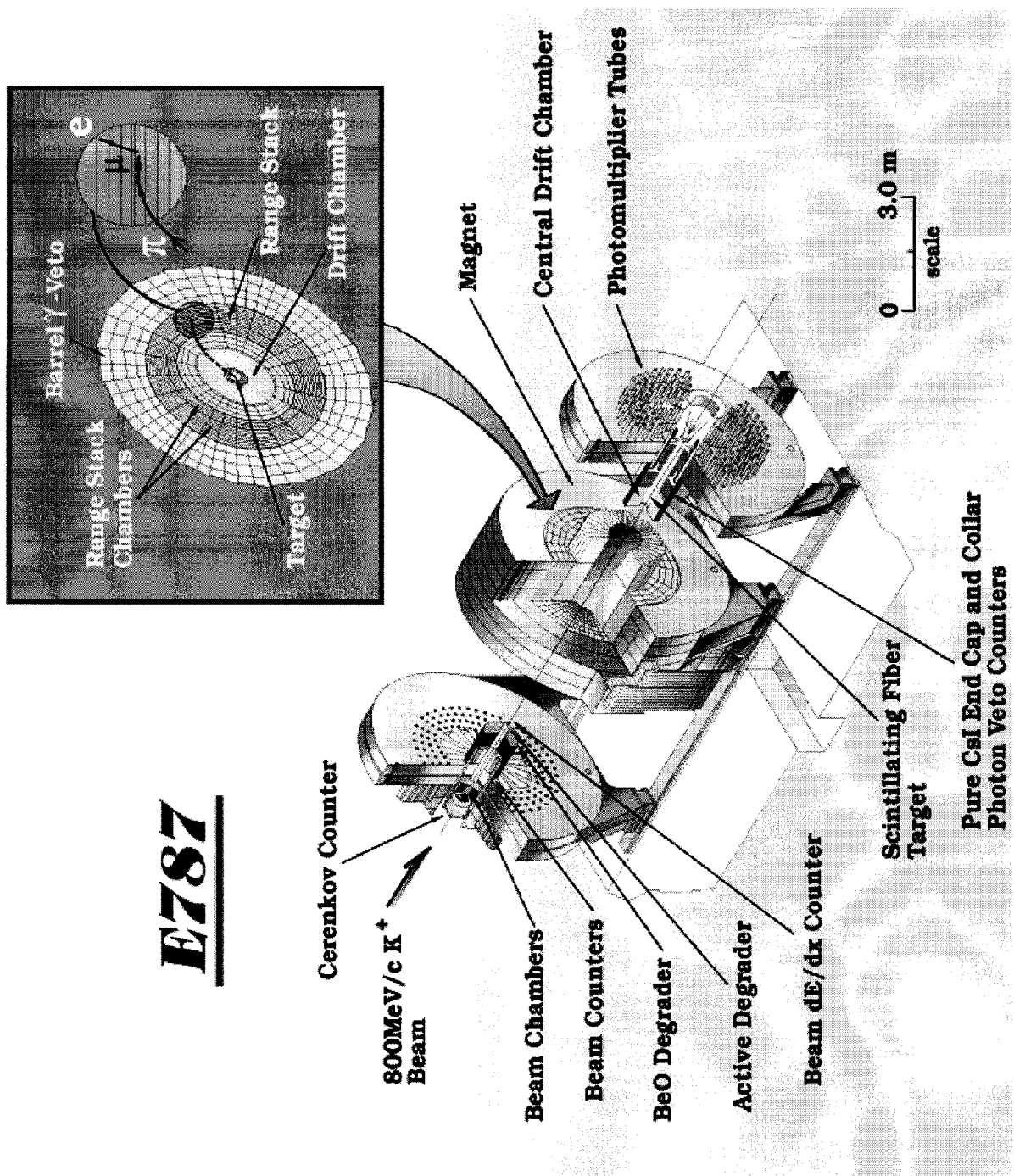

**EXPERIMENT 787 - A STUDY OF THE DECAY  $K^+ \rightarrow 6 B^+ \llcorner$**   
**Spokesmen: D. A. Bryman, L. S. Littenberg, A. J. S. Smith**

- **Brookhaven National Laboratory**  
S. Adler, M. S. Atiya, I-H. Chiang, M. Diwan, J. S. Frank, J. S. Haggerty, V. Jain,  
S. Kettell, T. F. Kycia, K. K. Li, L. S. Littenberg, C. F. Ng, R. C. Strand, C. Witzig
- **Fukui University**  
M. Miyajima, Y. Tamagawa
- **KEK-National Laboratory for High Energy Physics**  
M. Aoki, T. Inagaki, S. Kabe, M. Kobayashi, T. K. Komatsubara, Y. Kuno, M. Kuriki,  
T. Morimoto, N. Muramatsu, H. Okuno, K. Omata, A. Otomo, T. Sato, T. Shinkawa,  
S. Sugimoto, K. Ukai, Y. Yoshimura
- **Osaka University** - T. Nakano
- **Princeton University**  
A. Bazanko, P. D. Meyers, D. R. Relyea, F. C. Shoemaker, A. J. S. Smith, J. R. Stone
- **TRIUMF**  
P. Bergbusch, E. W. Blackmore, D. A. Bryman, P. Kapinus, A. Konaka, J. A. Macdonald,  
J. Mildner, T. Numao, J.-M. Poutissou, R. Poutissou, G. Redlinger
- **University of Alberta**  
P. Kitching, S. Ng, R. Soluk

---

Experiment 787 is a search for reactions of the type  $K^+ \rightarrow 6 B^+ X$ , where X is a weakly interacting light neutral particle. The experiment is sensitive to such decays at the  $10^{-10}$  level. The prime candidate is  $K^+ \rightarrow 6 B^+ \llcorner$  which provides a uniquely stringent test of the Standard Model and its parameters because it is the only experimentally accessible process that is dominated by an unambiguously calculable higher order weak interaction. Two body decays  $K^+ \rightarrow 6 B^+ X$  are also searched for to place constraints on the existence of a variety of hypothetical particles such as axions, familons, hyperphotons and supersymmetric neutrals predicted by extensions to the SM. Several other rare decays including  $K^+ \rightarrow 6 B^+ \llcorner$ ,  $K^+ \rightarrow 6 B^+ \mu^+ \mu^-$ ,  $B^0 \rightarrow 6 \llcorner$ , and  $B^0 \rightarrow 6 \llcorner$  are also being investigated. The former two,  $K^+ \rightarrow 6 B^+ \llcorner$  and  $K^+ \rightarrow 6 B^+ \mu^+ \mu^-$ , were discovered by this experiment. Recently a candidate for  $K^+ \rightarrow 6 B^+ \llcorner$  was observed by E787.

# EXPERIMENT 813

Home Page • <http://www.phys.cmu.edu/e813/e813.html>

---

## Target Geometry – E813

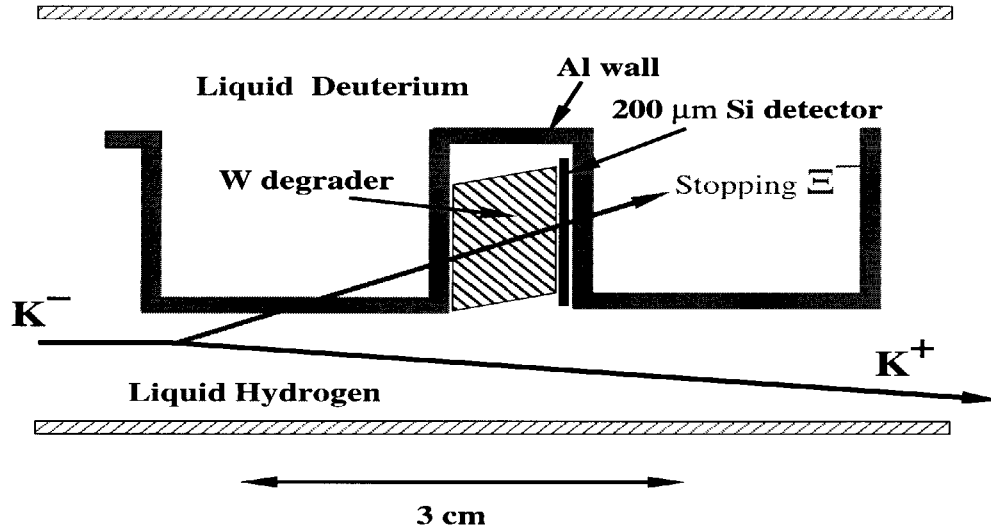

## Top View

### E813 Neutron detectors

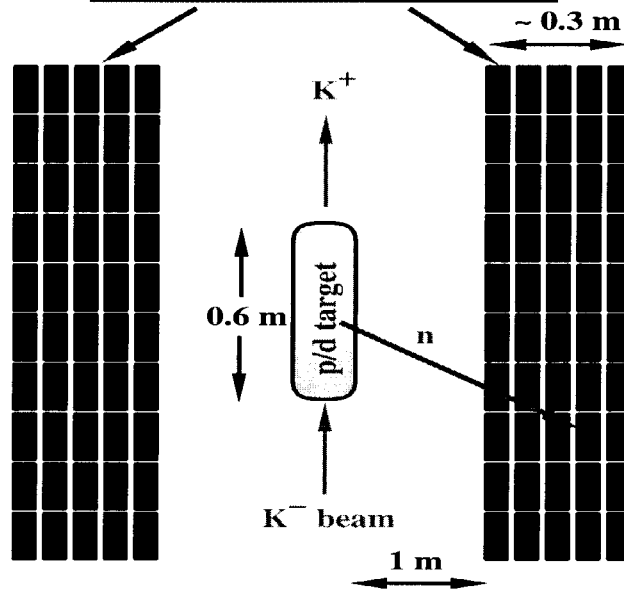

**EXPERIMENT 813 - SEARCH FOR A STRANGENESS -2 DIBARYON**

**Spokesmen: G. B. Franklin and P. D. Barnes**

- **Brookhaven National Laboratory** - R. Chrien, P. Pile, R. Sawafta, R. Sutter
- **Carnegie-Mellon University** - A. Berdoz, G. Franklin, R. Magahiz, R. McCrady, F. Merrill, C. Meyer, B. Quinn, R. A. Schumacher, R. Sukaton, V. Zeps
- **Freiburg University**  
T. Bürger, M. Burger, H. Fischer, J. Franz, E. Rössle, H. Schmitt, M. Wieder
- **Indiana Univ. Cyclotron Facility** - J. Szymanski
- **LAMPF** - P. Barnes
- **TRIUMF** - D. Gill
- **Vassar College** - R. Stearns
- **Yale University** - G. Diebold
- **University of Alberta** - M. Rozon
- **University of Birmingham** - J. Lowe, J. Nelson, R. Zybert
- **University of Kyoto** - H. Enyo, T. Iijima, K. Imai, N. Saito, S. Yokkaichi
- **University of Kyoto-Sangyo** - K. Okada, F. Takeuchi
- **University of Manitoba** -  
C. Davis, L. Gan, M. Landry, L. Lee, S. Page, D. Ramsay, V. Sum, W. van Oers
- **University of New Mexico** - B. Bassalleck, M. Chapman, A. Rusek, R. Stotzer, D. Wolfe

---

Motivated by Jaffe's 1977 prediction of a six-quark object with strangeness -2 and  $J^P = 0^+$  at a mass of 2150, this experiment proposed to study the strangeness of -2 two-baryon mass spectrum from 100 MeV below the mass of the lightest known two-baryon strangeness -2 system, 77 mass. This particle, called the "H," has been predicted by later bag models as well. Although the mass calculation is model dependent, the predictions are considered within the expected range of sensitivity. The possibility of resonances near the 77 mass due to conventional meson exchange forces can also be explored using the experiment covers the region both above and below the 77 mass.

## EXPERIMENT 821

Home Page • <http://www.phy.bnl.gov/g2muon/home.html>

---

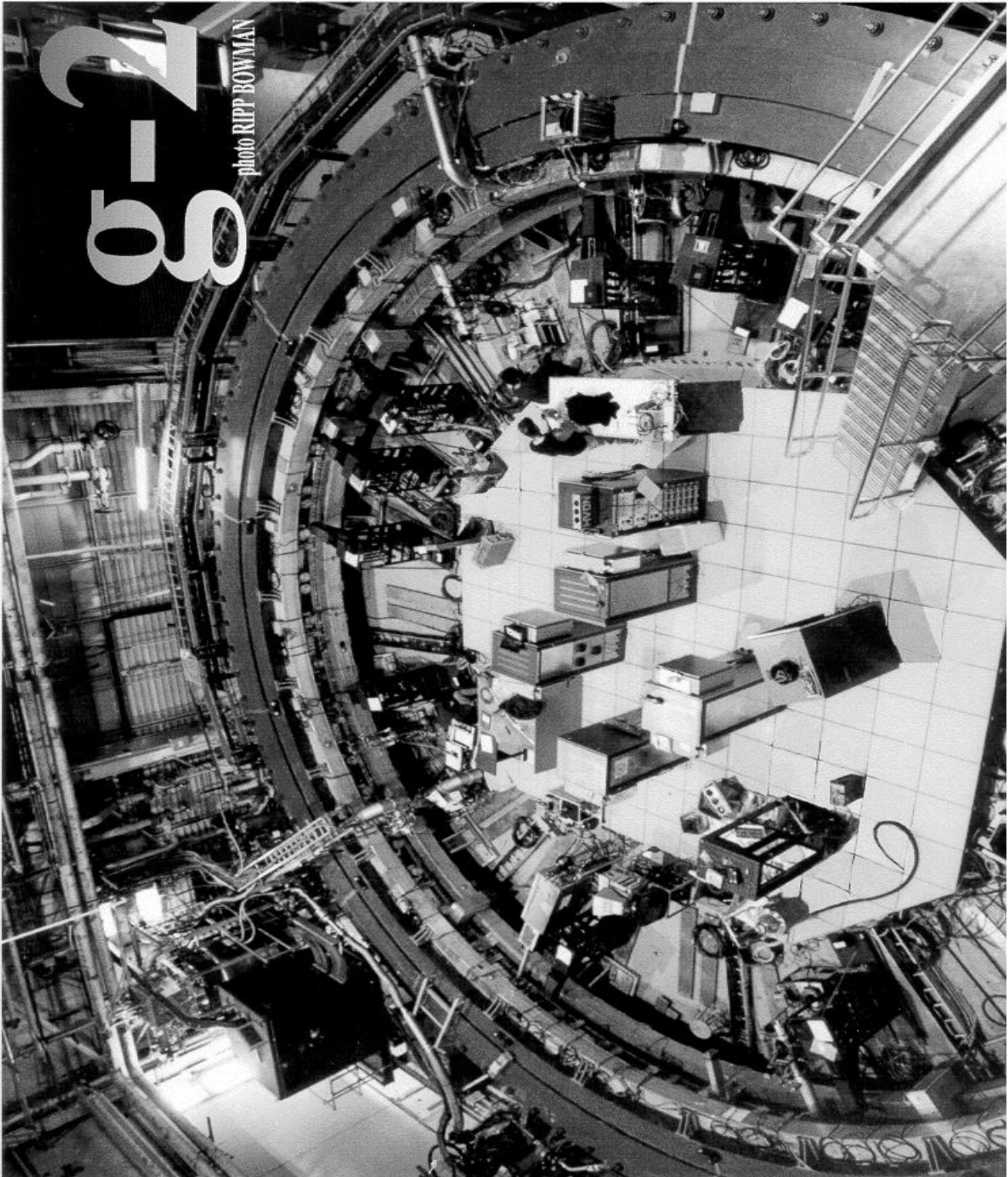



**EXPERIMENT 821 - A NEW PRECISION MEASUREMENT OF THE MUON G-2  
AT THE LEVEL OF 0.35 PPM  
Spokesmen: V.W. Hughes, W.M. Morse, B.L. Roberts**

- **Boston University** - R.M. Carey, W. Earle, E. Efsthadiadis, M. Hare, E.S. Hazen, F. Krienen, J.P. Miller, O. Rind, B.L. Roberts, L.R. Sulak, A. Trofimov
- **Brookhaven National Laboratory** - H.N. Brown, G. Bunce, G.T. Danby, R. Larsen, Y. Y. Lee, W.-Z. Meng, W.M. Morse, C. Pai, R. Prigl, S. Rankowitz, J. Sandberg, R. Sanders, Y. Semertzidis, R. Shutt, L. Snydstrup, A. Soukas,
- **Budker Institute for Nuclear Physics** - V.P. Druzhinin, G.V. Fedotovitch, B.I. Khazin, I. Logashenko, N. Ryskulov, S. Serednyakov, Yu.M. Shatunov, E. Solodov
- **Cornell University** - T. Kinoshita, Y. Orlov
- **Fairfield University** - D. Winn
- **Lawrence Berkeley Lab./Brookhaven National Lab.** - M.A. Green
- **Max Planck Institut für Physik** - U. Haeberlen
- **National Laboratory for High Energy Physics (KEK)** - A. Yamamoto
- **Tokyo Institute of Technology** - M. Iwasaki, M. Kawamura
- **Yale University** - H. Deng, S.K. Dhanan, F.J.M. Farley, M. Grosse-Perkekamp, V.W. Hughes, D. Kawall, S.I. Redin
- **University of Heidelberg** - A. Grossmann, K. Jungmann, G. zu Putlitz
- **University of Illinois** - P. Debevec, W. Deninger, D.W. Hertzog, C. Polly, S. Sedyky, D. Urner
- **University of Minnesota** - P. Cushman, L. Duong, S. Giron, J. Kindem, R. McNabb, D. Miller, C. Timmermans, D. Zimmerman

---

The anomalous gyromagnetic ratio of the muon ( $g-2$ ) will be measured to 0.35 ppm or a factor of 20 times better than it is currently known. The predicted contribution to ( $g-2$ ) from the first and second order  $W^\pm$  and  $Z^0$  radiative corrections is predicted to be 1.3 ppm, so this experiment will provide a direct test of the electroweak radiative corrections, and hence of the renormalizability of the Glashow-Weinberg-Salam theory. Since  $a_\mu$  is sensitive to a wide range of non-standard model effects there is a window in which to search for new physics.  $W$  or muon substructure, super-symmetry and the existence of new gauge bosons are several possibilities. A 14 m diameter superferric muon storage ring is now operational. Data collection will begin in FY 1997.

**EXPERIMENT 850**

Home Page • <http://www.phys.psu.edu/LEPS/EVA/eva.html>

---

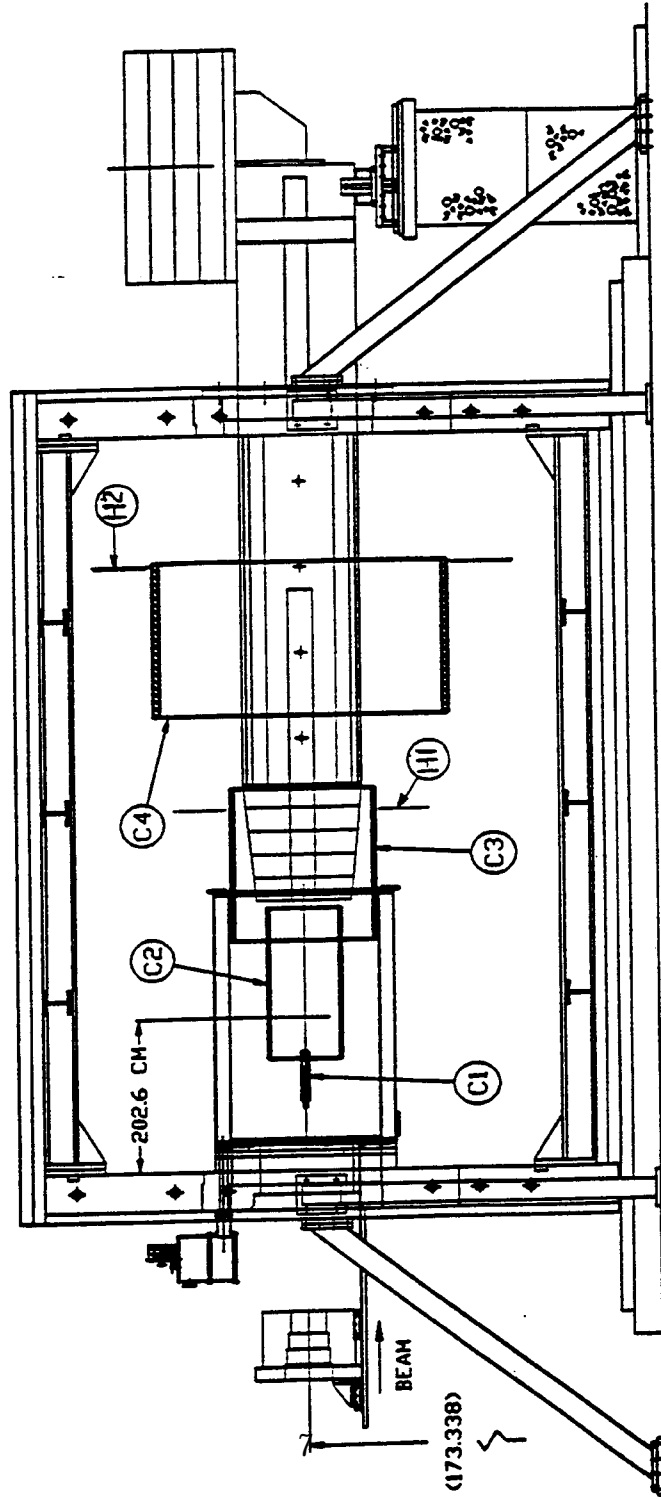

**EVA, A SOLENOIDAL DETECTOR FOR LARGE ANGLE EXCLUSIVE REACTIONS**  
**EXPERIMENT 850 - DETERMINING COLOR TRANSPARENCY**  
**Spokesmen: A.S. Carroll and S. Heppelmann**

- **Brookhaven National Laboratory**  
D.S. Barton, G. Bunce, A.S. Carroll, S. Gushue, Y.I. Makdisi, T. Roser
- **JINR., Dubna**  
Y. Panebratsev, S. Shimanskiy, I. O. Tsvetkov
- **Mt. Holyoke College** - H. Nicholson, C. S. Sutton
- **Pennsylvania State University**  
V. Baturin, S. Heppelmann, A. Leksanov, E. Minor, A. Ogawa, D. Tsalov
- **Tel-Aviv University**  
H. Aclander, J. Alster, S. Durant, E. Kosonovsky, I. Mardor, Y. Mardor, I. Navon,  
E. Piasetzky
- **University of Auckland** - N. Christensen
- **University of Massachusetts-Dartmouth** - J.J. Russell

---

In order to extend the range and sensitivity of measurements of large angle exclusive reactions, a new solenoidal detector, EVA, has been built. This detector increases the solid angle acceptance by over a factor of 20 over the existing dipole detector of E834, and provides for momentum measurements of all outgoing particles. The initial experiment, E850, has made new determinations of color transparency for carbon nuclei. Also measurements of carbon spectral functions at large momentum transfers were made. With a neutron detector, the correlations of neutrons associated with quasi-elastic (p,2p) reactions were determined. The solenoidal magnet which has not had reliable operation, has been substantially rebuilt, and now performs in a satisfactory manner.

**Experiment 852**

Home Page • [http://lemond.phy.bnl.gov/~e852/home\\_e852.html](http://lemond.phy.bnl.gov/~e852/home_e852.html)

---

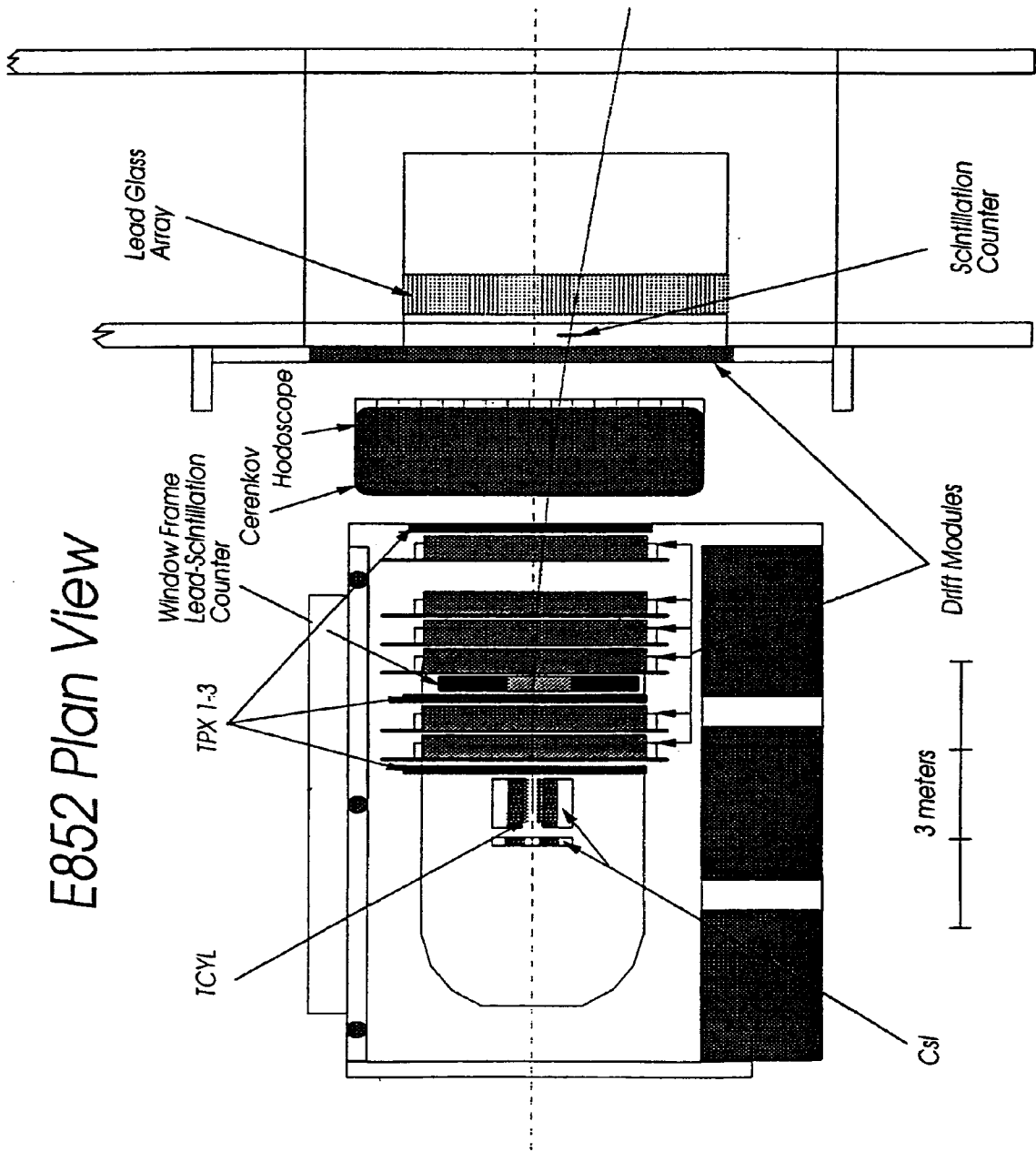

**EXPERIMENT 852 - SEARCH FOR MESONS WITH UNUSUAL QUANTUM NUMBERS**  
**Spokesmen: N. Cason and S.U. Chung**

- **Brookhaven National Laboratory** - S.U. Chung, K. Danyo-Blackett, R. W. Hackenburg, K. Olchanski, D.P. Weygand, H.J Willutzki
- **Indiana University** - B.B. Brabson, R.R. Crittenden, A.R. Dzierba, R. Gardner, J Gunter, R. Lindenbusch, D.R. Rust, E. Scott, P.T. Smith, T. Sulanke, S. Teige,
- **University of Massachusetts-Dartmouth** - Z. Bar-Yam, J Dowd, P. Eugenio, M. Hayek, W. Kern, E. King
- **Moscow State University** - L. I. Belzer, V. A. Bodyagain, A. Demianoi, A.M. Gribushin, O.L. Kodolva, V.L. Korotkikh, M.A. Kostin, N. Kurglov, A.I. Ostrovidov, A. Proskuryakov, L. I. Sarycheva, N. B. Sinev, I. N. Vardanyan, A. A. Yershov
- **Northwestern University** - D. S. Brown, T. Pedlar, K. Seth, J Wise, D. Zhao
- **University of Notre Dame** - T. Adams, JM. Bishop, N.M. Cason, E.I. Ivanov, JM. LoSecco, J J Manak, A. Sanjari, W. D. Shephard, D. L. Stenike, S. A. Tæger, D.R. Thompson
- **Institute for High Energy Physics - Protvino, Russia** - S. Denisov, V. A. Dorofeev, A. Dushkin, I. A. Kachaev, V. Kochetkov, V. Lipaev, A. V. Popov, D. I. Ryabchikov, I. Shein, A. Soldatov
- **Rensselaer Polytechnic Institute** - G. Adams, J P. Cummings, J Kuhn, J Napolitano, M. Nozar, J Smith, D. White, M. Witkowski

---

Despite a number of experimental searches there is still no unambiguous candidate for a glueball, hybrid or four-quark state, although QCD predicts such objects. However, there are some tantalizing states, among them the ME(1405) which has exotic  $J^C = 1^+$  and the scalar G(1590) which has unusual branching ratios for a quark-antiquark state.

The experimenters will study these and other states, concentrating on decay modes of mesons with multi-photons and 0, 1 or 2 charged particles. The detector is built around the MPS. The target will be surrounded by a CsI veto, charged particle detectors and a scintillation counter. The target will be followed by charged particle detectors, a Cerenkov counter and a 3000-element lead glass calorimeter to detect photons from meson decays.

**EXPERIMENT 856**  
Home Page • [http:](http://)

---

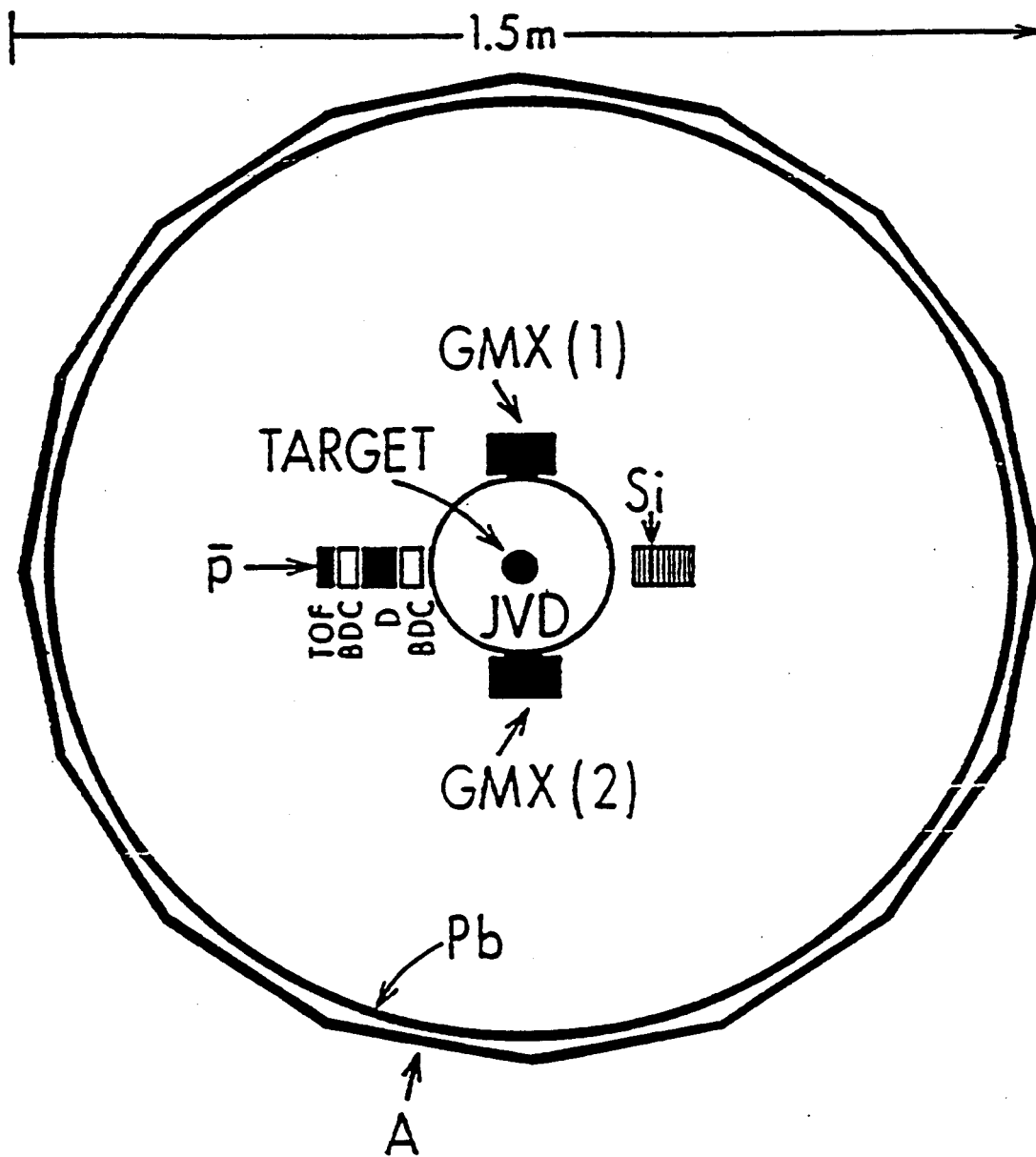

**EXPERIMENT 856 - EXPLORATION OF THE BIO MEDICAL POTENTIAL OF ANTI PROTONS**  
**Spokesman: T. Kalogeropoulos**

- **Brookhaven National Laboratory**  
S. Bart, G. Bennett, R. Chrien, M. Sakitt, R. Saw afta, R. Sutter
  - **Case Western Reserve University** - W. Fickinger, D. K. Robinson
  - **Harvard Cyclotron Laboratory** - A. Koehler
  - **Loma Linda University** - J. Archambeau
  - **Syracuse University** - T. Kalogeropoulos, J. Reed, Z. Sobolewski
  - **SUNY Health Science Center** - D. Bassano, S. Manglos, S. C. Prasad
  - **University of Massachusetts** - A. B. Brill
- 

The potential of antiprotons for practical applications within present antiproton collection capabilities is promising. Suggested applications include direct 3D electron density imaging, 3D multi-elemental imaging, guiding precise and easy delivery of ion beams to targets, and radiation therapy.

In this initial phase of the research, the following physics questions will be addressed: (a) Comparison of antiproton capture rates in complex targets with the Z-law; (b) Studies of the annihilation mechanism in nuclei. These studies of physics are interesting on their own right and will provide basic information in evaluating the proposed applications as well.

**EXPERIMENT 864**

Home Page • <http://quantum.phy.vanderbilt.edu/e864>

**E864, Strangelet Search Experiment**

The E864 "Spectrometer" measures

- Charge ( $Z$ ) and Mass ( $M$ )
- Strangelets from  $M > 7 \text{ GeV}/c^2$  with  $Z/M < 0.3 \text{ e}/\text{GeV}/c^2$

**Elevation View**

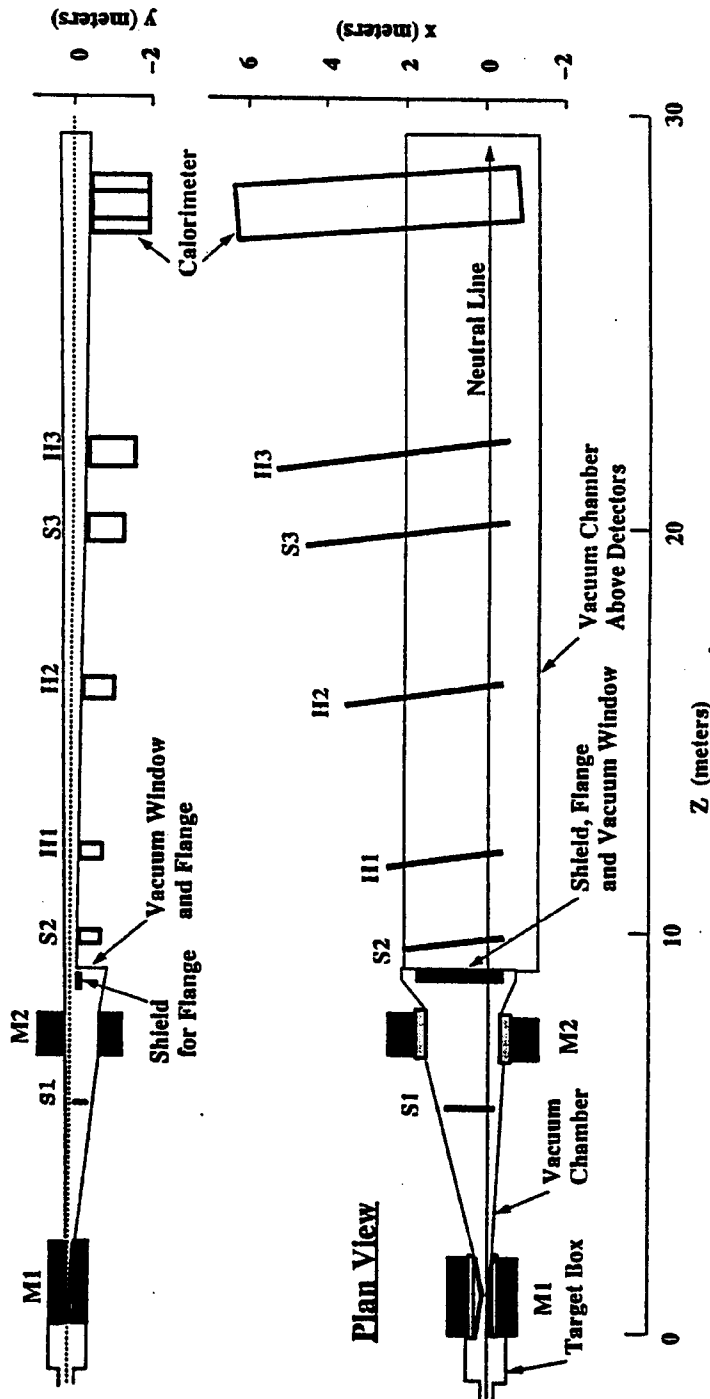

M1 & M2 - dipole spectrometer magnets  
 H1, H2 & H3 - scintillation hodoscopes  
 S1, S2 & S3 - straw tube arrays



**EXPERIMENT 864 - PRODUCTION OF RARE COMPOSITE OBJECTS  
IN RELATIVISTIC HEAVY ION COLLISIONS  
Spokesman: J Sandweiss**

- **Ames Laboratory** - H. Skank, G. Sleege
- **Brookhaven National Laboratory** - T. G. Thorne
- **Iowa State University** - L. Ewell, K. Haversten, J. C. Hill, B. Libby, F. K. Wohn
- **Massachusetts Institute of Technology** - E. S. Hafën, P. Haridas, I. Pless, G. Van Buren
- **Penn State University** - T. Armstrong, R. A. Lewis, G. A. Smith
- **Purdue University** - R. M. Davies, A. S. Hirsch, N. T. Porile, R. P. Scharenberg,  
B. K. Srivastava, B. C. Stringfellow, M. L. Tincknell
- **Vanderbilt University** - V. S. Greene, J. Reid
- **Wayne State University** - R. Bellwied, B. Bennett, T. Cormier, J. Hall, C. Pruneau
- **Yale University** - S. Coe, N. George, J. Lajoie, R. D. Majka, J. Nagle, J. K. Pope,  
F. S. Rotondo, J. Sandweiss, B. Shiva Kumar, A. J. Slaughter
- **University of Bari, Italy** - P. Spinnelli
- **University of California-Los Angeles** - K. Barish, H. Z. Huang
- **University of Massachusetts** - M. S. Z. Rabin

---

The experimenters have begun to carry out a systematic set of measurements and searches for "composite" objects produced in high energy heavy ion collisions. These measurements are aimed at studies utilizing the heaviest ions available at the AGS, including gold ions. A major focus of the experiment is on charged composites; however, studies of neutral systems are also considered significant in the study. The experiment is designed to study particles produced in the central region of rapidity which are produced in central collisions. Since composite systems must be produced by the overlap of particles produced in the collision, it is expected that composites will be made mostly in the central rapidity region where overlaps would be most probable.

**EXPERIMENT 865**

Home Page • <http://pony.phy.bnl.gov/~hma/hma/html>

---

E865 Apparatus  
Plan Diagram

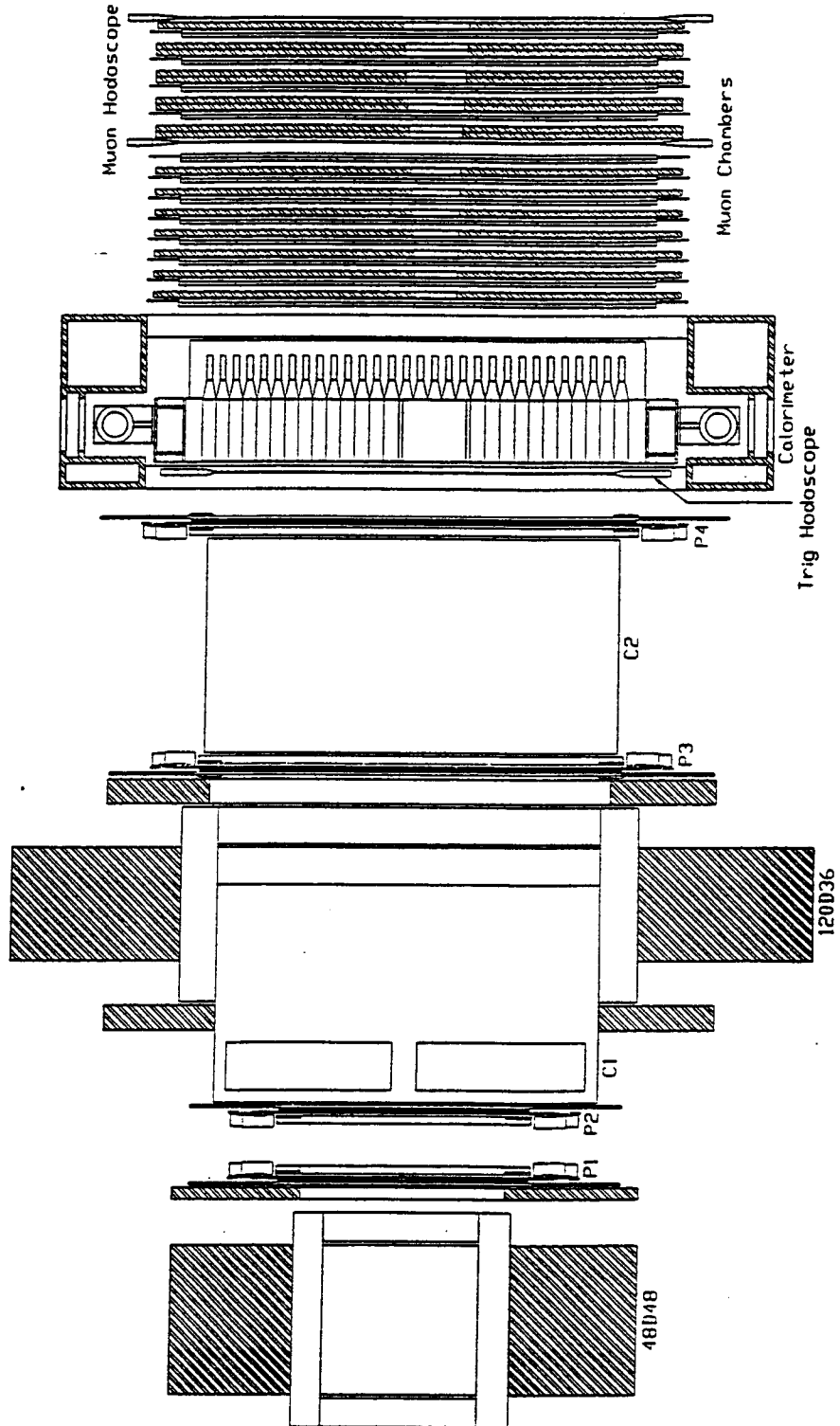

**EXPERIMENT 865 - PROPOSAL TO PERFORM AN IMPROVED SEARCH FOR THE DECAY**

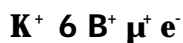

**Spokesman: M. E. Zeller**

- **Brookhaven National Laboratory** - D. Lazarus, L. Leipuner, H. Ma, B. Magurno, P. Rehak
- **Hampton University** - K. Assamagan, K. Baker
- **High Energy Physics Inst. Tbilisi State University** - N. Amaglobeli, Y. Bagaturia, D. Mazavia, T. Sachelashvili
- **Institute for Nuclear Research, Academy of Sciences of Russia (Moscow)** - G. S. Atoian, S. N. Gninenko, V. V. Issakov, V. Lebedev, A. A. Poblaguev, V. Postoev, A. Proskuryakov
- **Paul Scherrer Institute** - J. Egger, W. D. Herold, H. Kaspar, H. Weyer
- **Yale University** - D. Bergman, S. Dhawan, H. Do, W. Majid, M. E. Zeller
- **University of Basel** - W. Menzel
- **University of Bern** - J. Gasser
- **University of Connecticut** - J. Lozano
- **University of New Mexico** - J. Armendariz, B. Bassalleck, S. Eilerts, H. Fischer, J. Lowe, R. Stotzer, D. Wolfe
- **University of Pittsburgh** - R. Appel, C. Felder, B. Giles, D. E. Kraus, J.A. Thompson
- **University of Zurich** - S. Pislak, P. Robmann, P. Truoei

---

E865, a second generation search for  $K^+ \rightarrow 6 B^+ \mu^+ e^-$  at the branching ratio level of  $\sim 3 \times 10^{-12}$ , a factor of 70 improvement over the previous limit of  $2.1 \times 10^{-10}$ . Data obtained in the FY95 run show a clear  $K^+ \rightarrow 6 B^+ \mu^+ e^-$  signal above background visible on one data tape or about one shift of running. The branching ratio for this decay was measured to be  $2.8 \times 10^{-7}$  in E851 and a few hours of running gathers more events than the world sample of 41 events that existed prior to the BNL rare kaon decay program. From this rate and those for  $K^+ \rightarrow 6 B^+ B^+ B^-$  and  $K^+ \rightarrow 6 B^+ B^0$  followed by  $B^0 \rightarrow 6 e^+ e^-$  (we estimate our current branching ratio sensitivity to be  $< 5 \times 10^{-11}$  for  $K^+ \rightarrow 6 B^+ \mu^+ e^-$ , well beyond  $2.2 \times 10^{-10}$  obtained in E777).

An upgrade of the data acquisition system should result in a factor of two increase in data rate in FY96. Additions to the experiment include special triggering electronics for the decay  $K^+ \rightarrow 6 B^+ \mu^+ \mu^-$  and a beam tracking detector in order to improve vertex reconstruction and sensitivity to rare decays with missing energy.

# EXPERIMENT 866

Home Page • [http://sys0.hirg.bnl.gov/world\\_access/e866.html](http://sys0.hirg.bnl.gov/world_access/e866.html)

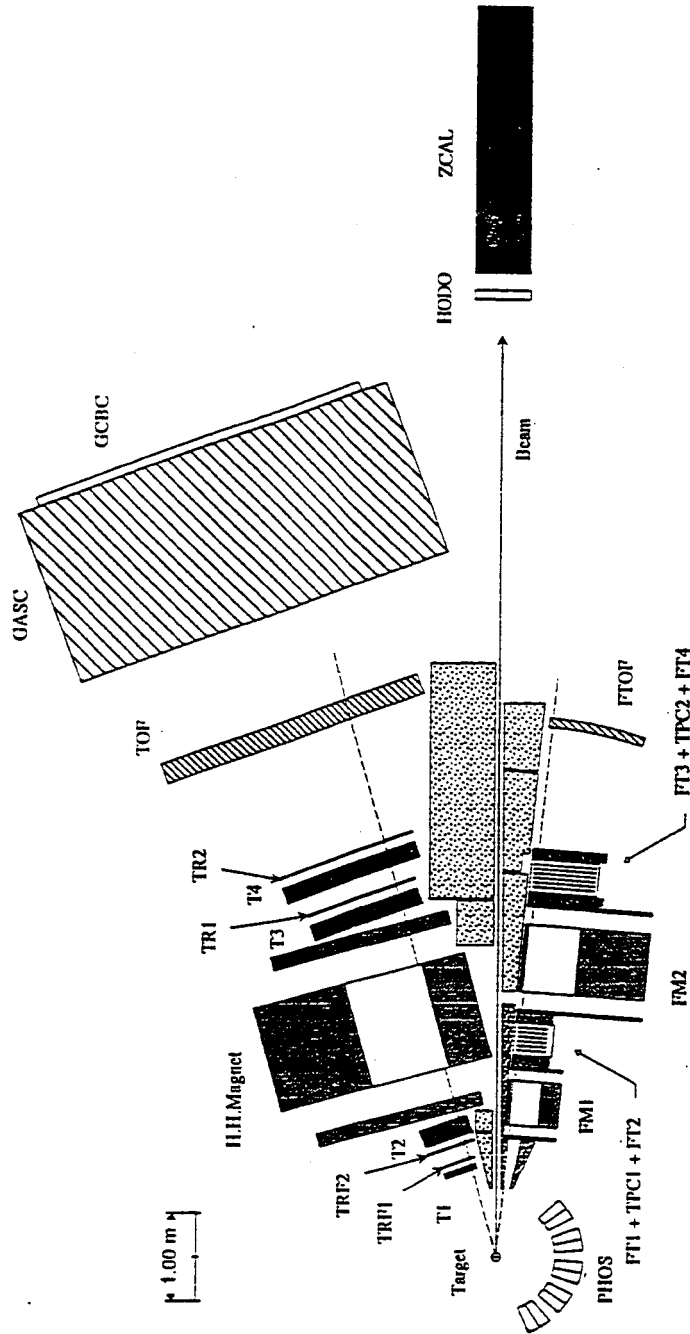

**EXPERIMENT 866 - STUDIES OF PARTICLE PRODUCTION AT HIGH BARYON DENSITY  
USING THE AU BEAM**

**Co-Spokesmen:**

**C. Chasman**

**Alternating Co-Spokesmen:**

**H. Hamagaki and S. Steadman**

- **Brookhaven National Laboratory** - K. Ashktorab, D. Beavis, C. Chasman, Z. Chen, Y. Y. Chu, J. B. Cumming, R. Debbe, S. Gushue, J. H. Lee, M. LeVine, B. Moskowitz, C. Muentz, J. Olness, L. P. Remsberg, M. J. Tannenbaum, F. Videbaek, F. Zhu
- **Columbia University** - I. Chemakin, C. Y. Chi, B. A. Cole, M. Moulson, S. Nagamiya, F. Wang, Y. Wang, Y. Wu, X. Yang, W. A. Zajc
- **Institute for Nuclear Study-University of Tokyo** - Y. Akiba, H. Hamagaki, S. Homma, H. Sako
- **Kyoto University** - H. Kaneko
- **Lawrence Livermore Laboratory** - H. C. Britt, M. N. Namboodiri, T. Sangster, R. Soltz, J. H. Thomas
- **Massachusetts Institute of Technology** - L. Ahle, M. Baker, V. Cianciolo, J. Dunlop, G. Heintzelman, C. Ogilvie, J. Ryan, S. G. Steadman, G. S. F. Stephens, D. Woodruff, H. Yao
- **New York University** - B. Budick
- **Yonsei University** - J. Kang, E. J. Kim
- **University of California, Space Sciences Laboratory** - H. J. Crawford, J. Engelage, E. Judd
- **University of California at Riverside** - J. Chang, W. Eldredge, S.-Y. Fung, H. Liu, R. Seto, H. Xiang, Q. Xu, Q. Zhu
- **University of Maryland** - E. Garcia, A. Mignerey, J. Shea
- **University of Tokyo** - R. S. Hayano
- **University of Tsukuba** - A. Kumagai, K. Kurita, Y. Miake, S. Sato, K. Yagi

---

In keeping with the original purpose of E802 and E859, this experiment will continue the investigation of semi-inclusive single particle spectra using the gold beam: (1) to measure the particle momentum spectra as a function of  $p_t$  and  $y'$  (2) to find how these cross sections vary with "central" or "peripheral" collisions as taken from the event characterizing detectors; (3) to measure two-particle correlations; (4) to look for systemic variations in the cross sections with different beams and targets so as to clarify the reaction dynamics; and (5) to seek evidence in this measurement for the production of very dense nuclear matter, or ultimately, the quark-gluon plasma.

**EXPERIMENT 868**

Beam: A3

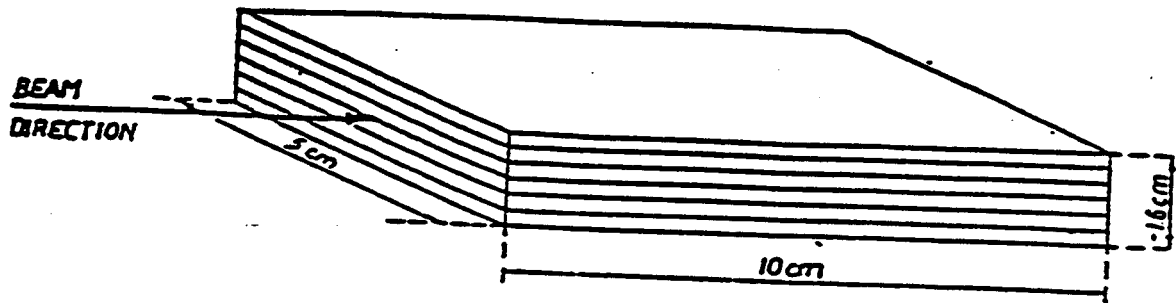

Schematic diagram of the emulsion stack exposures.

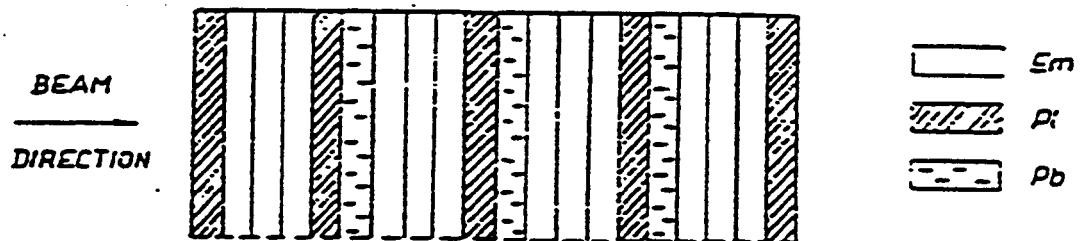

Schematic diagram of the emulsion chamber exposures.

**EXPERIMENT 868 - INTERACTIONS OF 10.6 GeV/NUCLEON  $^{197}\text{Au}$  NUCLEI IN NUCLEAR EMULSIONS**

**Spokesman: C.J. Waddington**

- **Institute of Nuclear Physics, Krakow**  
A. Dambrowska, R. Holynski, A. Jurak, A. Olszewski, M. Szarska, A. Trzupek,  
B. Wilczynska, H. Wilczynski, W. Wolter, B. Wosiek, K. Wozniak
- **Institute of Theory and Experimental Physics Moscow**  
A.I. Dubinina, O.K. Egorov, E.D. Kolganova, E.A. Pozharova, T.Yu. Skorotko,  
V.A. Smirnitcki
- **Louisiana State University**  
M.L. Cherry, P. Dienes-Jones, W.V. Jones, K. Sengupta, J.P. Wefel
- **University of Minnesota** - C.J. Waddington

---

The Krakow-Louisiana-Minnesota (KLMM) collaboration has previously exposed small stacks of nuclear emulsions to the light nuclei beams available from the AGS, Exp. 808. The results of this work, when combined with similar exposures of stacks and chambers made at CERN to higher energy beams, EMU07, have been reported in a number of published papers. In April 1992, when beams of heavier nuclei became available with the commissioning of the Booster, the collaboration exposed stacks and chambers of nuclear emulsions to a beam of gold nuclei with a nominal energy of 10.6 GeV/nucleon. Excellent exposures were obtained and the emulsions successfully processed at Dubna. Analysis by Minnesota and Krakow of the interactions in these emulsions has been completed and some of the results published. Further analysis of specific aspects is continuing and further publications can be expected.

Another exposure, conducted by Minnesota, was made in January 1996 to a beam of 4.0 GeV/n gold nuclei. These emulsions have been processed in Dubna and returned to Krakow, where they will be analyzed. No analysis will be possible in Minnesota due to a lack of funding. Inspection of these emulsions show that they were successfully exposed but are characterized by a heavy background.

# 1992 BNL layout Exp 869

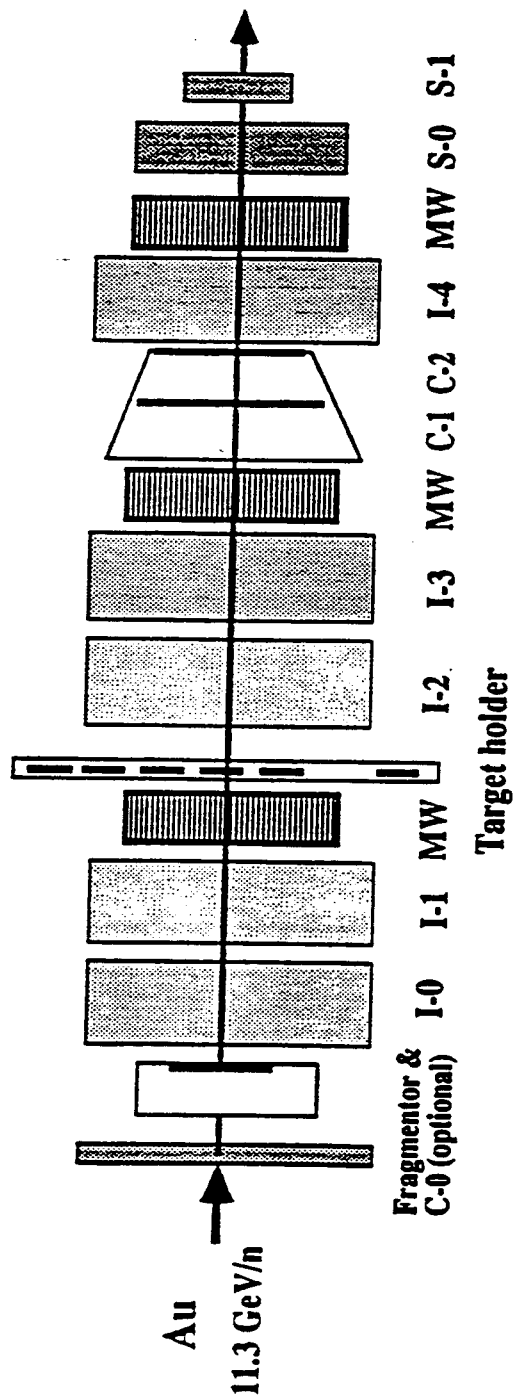

Schematic diagram of the detector setup used for the April 1992 AGS gold run. Ion chambers I - 0 to 4 are four gap parallel plate chambers filled with P10 gas. Cherenkov counters C - 0 to 3 contain radiators of Pilot 425 plastic mounted in white diffusion boxes. The multiwire proportional counters MW have 1 mm wire spacing. The target holder can place any of the targets in the beam by remote command. Thirty-two channels of data are recorded for each event at rates of up to 1,000 events/sec.



**EXPERIMENT 869 - MEASUREMENT OF FRAGMENT YIELDS FOR 14 GeV/NUCLEON  
AU + X COLLISIONS  
Spokesman: C. J Waddington**

- **Caltech** - J. R. Cummings, T. L. Garrard, E. C. Stone
  - **Washington University** - W. R. Binns, L. Y. Geer, J. Klarmann
  - **University of Minnesota** - B.S. Nilsen, C. J Waddington
- 

This experiment was proposed in order to continue a study of the fragmentation of ultra heavy, UH, nuclei begun at the Bevalac as part of a program of cosmic ray studies. It required additional experiments using the new Booster facility at the Brookhaven AGS. The experiments at the AGS would extend the energy range of the measurements upwards to match the energies of the majority of observed cosmic ray nuclei. These measurements would improve our ability to predict the partial cross sections for the production of fragments and allow better calculations of the abundances of the cosmic ray UH nuclei at the sources by taking account of the effects of propagation on the observed abundances. These measurements would also extend our current studies of the nuclear physics topics of factorization, limiting fragmentation, charge pickup, Coulomb dissociation and fission.

The detector array used during exposures to the AGS gold beam in April 1992 and January 1996 is shown. It consists of a combination of ion chambers and Cherenkov counters which identify the particles entering a target and then measure the sum of the charges emitted from interactions in the targets. During the 1992 exposure, 10.6 GeV/n gold projectiles were allowed to fall on targets of polyethylene, carbon, aluminum, copper, tin and lead. In each case sufficient data was taken to determine partial cross sections of 10 mb with better than 10% accuracy. In addition, a fragmentor was placed in the primary beam, generating secondary beams of fragments. Sufficient of these fragments were generated to allow partial cross sections to be determined in the targets for all projectiles between  $Z = 79$  and  $70$ . The excellent resolution of the detector array allows the identification of fragments with charges as low as  $Z = 50$  coming from gold projectiles.

In January 1996 a beam of 4.0 GeV/n gold nuclei was used in a similar set-up. In addition, data were taken at seven other lower energies using a combination of internal and external degraders. These results will allow a determination of the energy dependence of the partial cross sections, which will be very important in modeling the propagation of the heavy cosmic ray nuclei through the interstellar medium. The analysis of these data has only just begun.

# EXPERIMENT 871

Home Page • <http://egnext1.slac.stanford.edu/khue.html>

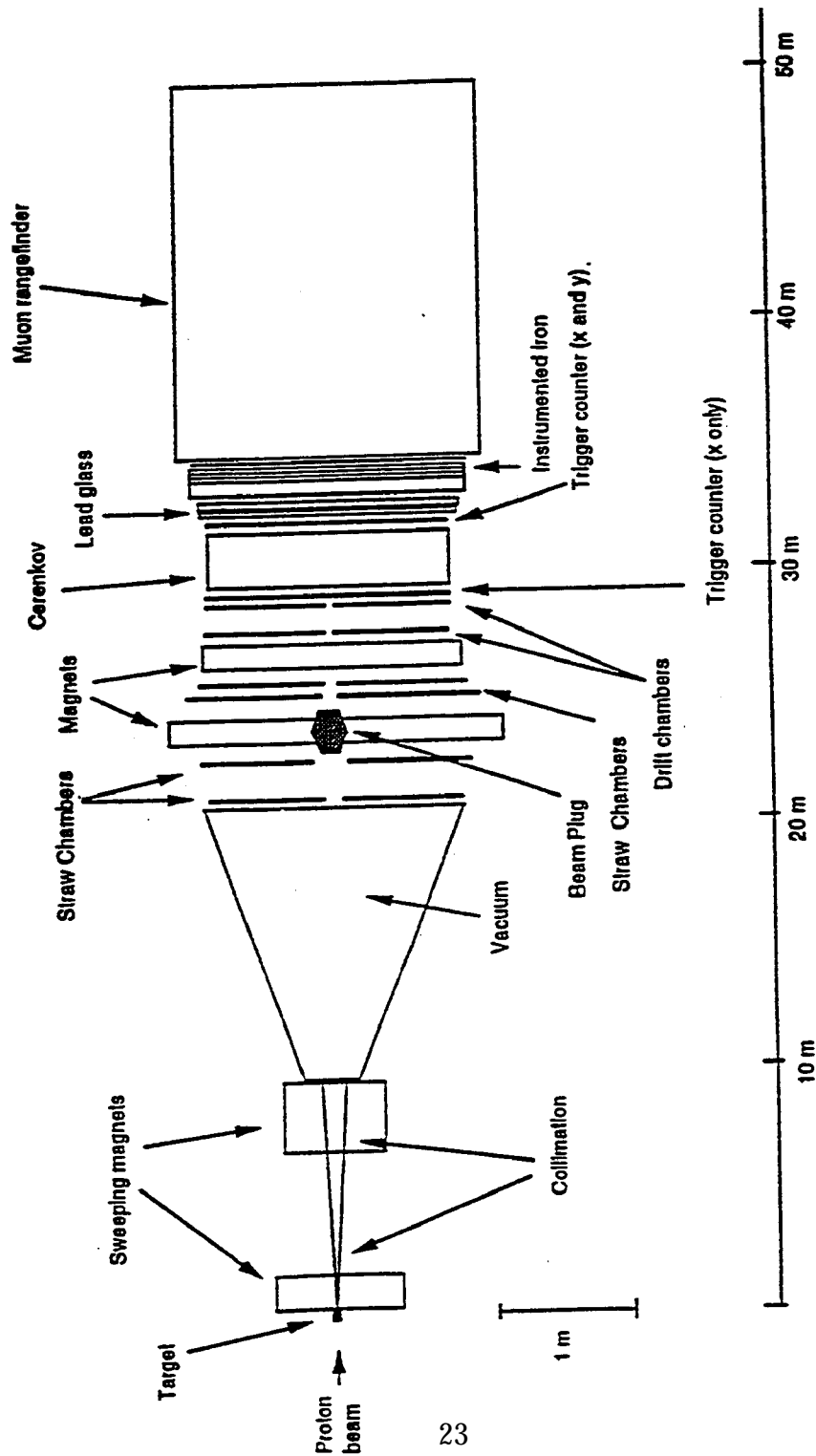

Beam: B5

**EXPERIMENT 871 - A NEW SEARCH FOR VERY RARE  $K_L^0$  DECAYS**  
**Spokesmen: J R. Kane, W. R. Molzon, J L Ritchie, S. G. Wojcicki**

- **College of William and Mary**  
M. Eckhause, A.D. Hancock, C. Hoff, J.R. Kane, Y. Kuang, R.D. Martin, R.E. Welsh, E. Wolin
- **Stanford University**  
K. Ecklund, C. Hartman, M. Hebert, G.M. Irwin, M. Pommot-Maia, S. G. Wojcicki
- **University of California at Irvine**  
M. Bachman, D. Connor, P. DeCecco, N. Kanematsu, R. Lee, W. R. Molzon
- **University of Richmond** - P. Rubin
- **University of Texas at Austin**  
D. Ambrose, S. Graessle, S. Hamilton, G. W. Hoffmann, K. Lang, M. R. Marcin, J McDonough, A. Milder, P. J Riley, J L Ritchie, C. B. Ware, S. Worm

---

This group is carrying out a new search for the decays  $K_L^0 \rightarrow 6 \mu e$  and  $K_L^0 \rightarrow 6 ee$ , building on the experience from the recently completed experiment, E791. The  $K_L \rightarrow 6 \mu \mu$  branching ratio measurement will also be improved. The final E791 single event sensitivity for  $K_L^0 \rightarrow 6 \mu e$  was about  $1-2 \times 10^{-11}$ . The new experiment will reach a single event sensitivity below  $10^{-12}$ , and if no events are observed, will set an upper limit of about  $2 \times 10^{-12}$ . About 10,000  $K_L^0 \rightarrow 6 \mu \mu$  decays will also be observed.

The experiment takes the novel approach of stopping the neutral beam in a beam stop near the upstream end of the spectrometer.

**EXPERIMENT 877**

Home Page • <http://skipper.physics.sunysb.edu/~e877/E877.html>

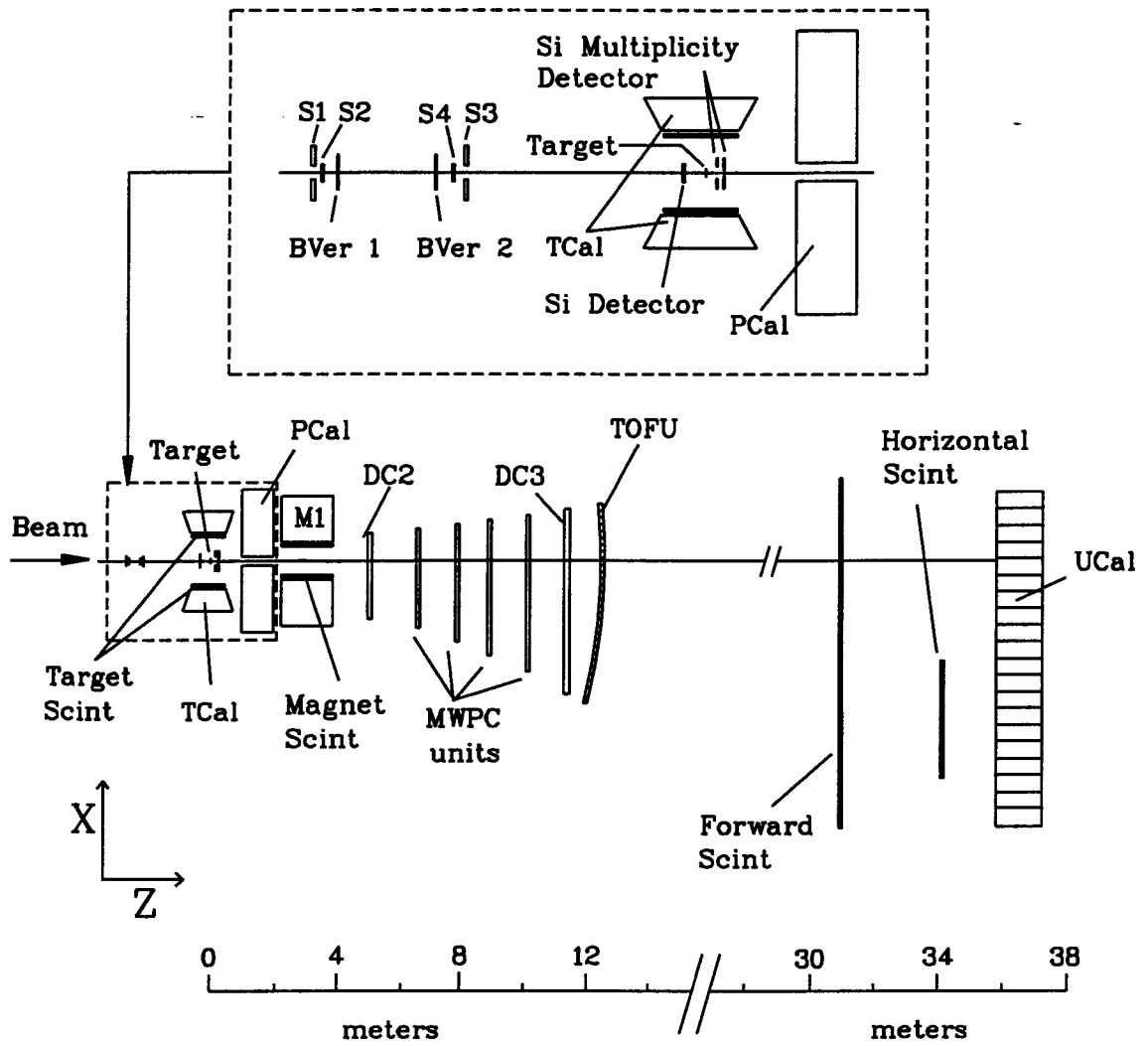

**EXPERIMENT 877 - STUDY OF RELATIVISTIC NUCLEAR COLLISIONS  
WITH HEAVY BEAMS USING THE E814 4B CALORIMETRY  
AND MODIFIED FORWARD SPECTROMETER  
Spokesman: P. Braun-Munzinger**

- **Brookhaven National Laboratory**  
G. David, T. Ludlam, S. McCorkle, E. O'Brien, M. Rosati, C. Woody
  - **GSI, Darmstadt** - N. Herrmann
  - **Idaho National Engineering Laboratory** - J. Cole, M. Drigert, E. Reber
  - **McGill University** - J. Barrette, Y. Dai, R. Lacasse, S. K. Mark, L. Normand, N. Starinsky
  - **SUNY at Stony Brook** - R. Bersch, P. Braun-Munzinger, T. K. Hemmick, B. Hong, S. Johnson, Y. Kwon, D. Miskowicz, S. Panitkin, P. Paul, T. Piazza, J. Stachel, M. Trzaska, T. Vongpaseuth, J. Wessels, Y. Zhang, C. Zhou
  - **Wayne State University**  
R. Bellwied, T. Budny, T. Cormier, A. French, F. Gang, J. Hall, B. Kim, K. Lahab, Q. Li, C. Pruneau, J. Sheen, H. Xiong
  - **University of Pittsburgh** - W. Cleland, M. Clemen, U. Sonnadara, S. Voloshin
  - **University of São Paulo** - N. DaSilva, O. Dietzsch, M. Takagui
- 

Using an upgraded E814 set-up, this experiment proposes to study central collisions between heavy nuclei and projectiles from the Booster/AGS accelerators. The main emphasis is on a detailed study of the energy flow into 4B and measurements of the spectra of nucleons and produced particles for rapidities  $y > 1.5$  and low transverse momenta, with event characterization over the full solid angle. In addition, nucleons, nuclear fragments and produced particles in the target fragmentation region will be measured.

**EXPERIMENT 880**

Home Page • <http://www.ags.bnl.gov/~huang/e880.html>

---

## Polarized Proton Experiments in the AGS with a Partial Siberian Snake (E880)

(ANL,BNL,INDIANA,TRIUMF,KEK,RIKEN,IHEP)

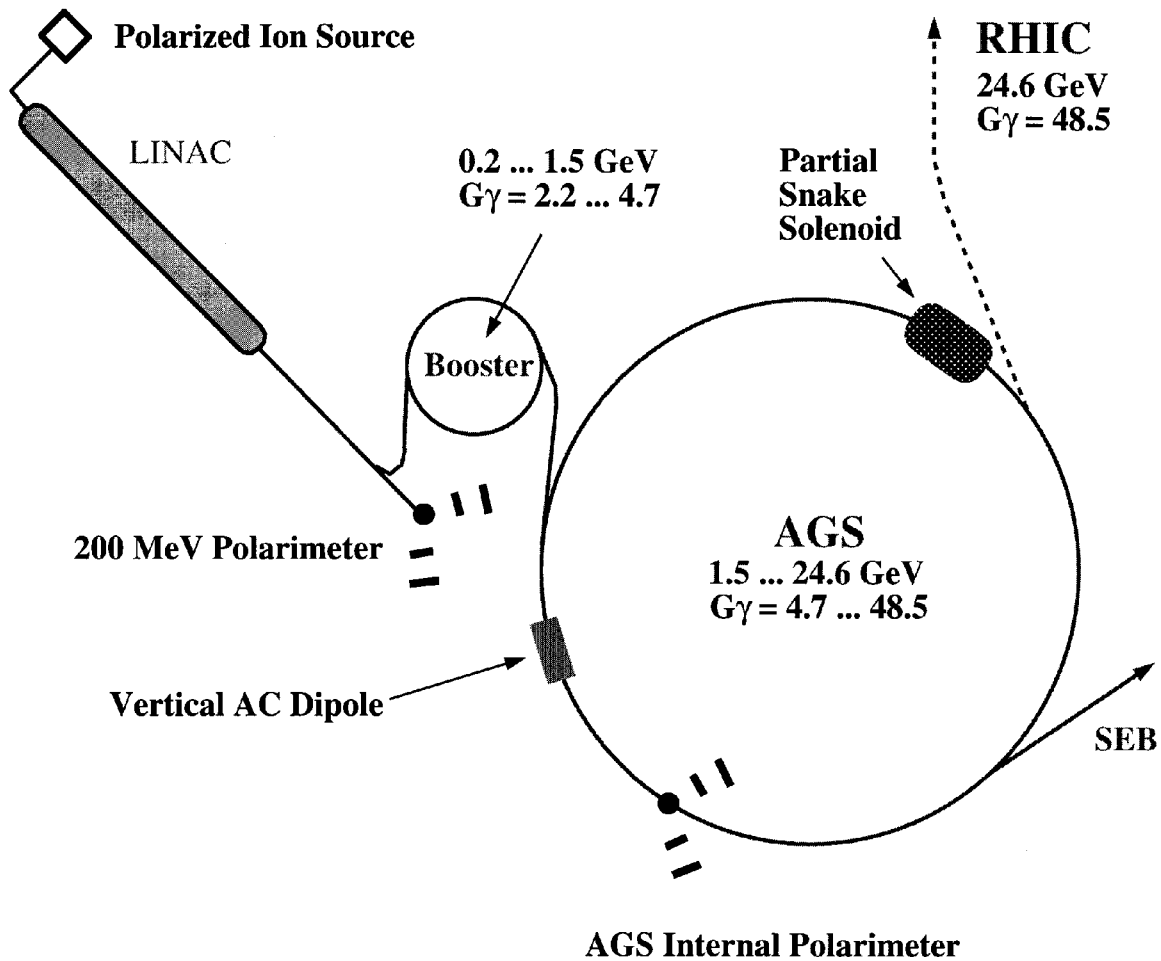

**EXPERIMENT 880 - THE EFFECTS OF A PARTIAL SIBERIAN SNAKE  
ON POLARIZATION AT THE AGS  
Spokesmen: S. Y. Lee and T. Roser**

- **Argonne National Laboratory** - C. Allgower, M. Bai,<sup>(1)</sup> K. Krueger, H. Spinka, L. Teng, D. G. Underwood, A. Yokosawa
- **Brookhaven National Laboratory** - L. Ahrens, J. Alessi, K. Brown, G. Bunce, P. Cameron, E. D. Courant, J. W. Glenn, H. Huang, P. Ingrassia, Y. Y. Lee, A. Luccio, Y. I. Makdisi, F. Mariani, L. Ratner, K. Reece, T. Roser, J. F. Skelly, A. Soukas, M. Syphers, S. Tepikian, R. E. Thern, N. Tsoupras, W. van Asselt, N. Williams
- **Fermilab** - V. Bharadwaj, S. Hseuh
- **Indiana University IUCF** - P. Chu, D. Jeon, W. Lambie, S. Y. Lee
- **Institute for High Energy Physics, Serpukhov** - A. Ufimtsev
- **KEK** - S. Hiramatsu, Y. Mori, H. Sato, K. Yokoya
- **Riken** - T. Katayama, M. Okamura, T. Tomiyama
- **TRIUMF** - U. Wienands<sup>(2)</sup>

---

This group has built a 4.7 Tesla-meter room temperature solenoid which will be installed in a 10-foot long AGS straight section. AGS polarized proton beam time is used to perform *partial snake experiments*. These experiments tested successfully the idea of using a partial snake to correct all depolarizing imperfection resonances. Intrinsic depolarizing resonances are successfully overcome by using an AC vertical dipole to generate coherent betatron oscillation.

(1) Also at Indiana University  
(2) Present address: SLAC

## EXPERIMENT 885

Home Page • <http://www.phys.cmu.edu/e885.e885.html>

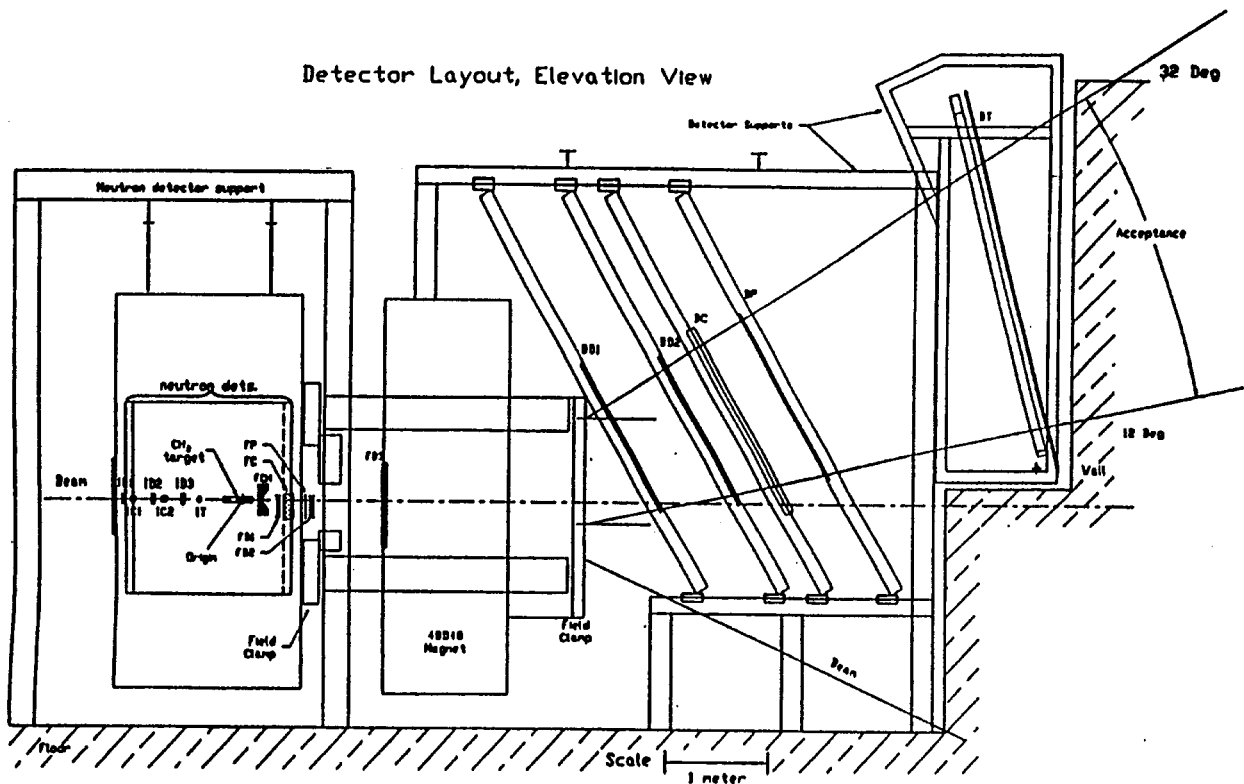

Detector configuration for  $\Lambda\Lambda$  experiment. Drift chambers ID1, ID2, and ID3 determine incoming  $K^-$  trajectory and are combined with upstream hodoscope data to determine  $K^-$  momentum. Drift Chambers FD1, FD2, FD3, BD1 and BD2 determine  $K^+$  momentum. Scintillators IT and BT determine  $K^+$  time-of-flight. Hodoscopes FP and BP determine spectrometer acceptance. Aerogel Cerenkovs IC1, IC2, FC, and BC reject pions. Hydrogen Cerenkov FCH rejects protons.



**EXPERIMENT 885 - EXPERIMENT TO DETECT 77 HYPERNUCLEI**  
**Spokesmen: M. May, G. Franklin and C. Davis**

- **Brookhaven National Laboratory** - D. Alburger, R. E. Chrien, M. May, P. H. Pile, A. Rusek, R. Sawafta, R. Sutter
- **Carnegie-Mellon University** - A. Berdoz, A. Biglan, D. Carman, G. Franklin, P. Khaustov, P. Koran, R. Magahiz, R. McCrady, C. Meyer, K. Paschke, B. Quinn, R. Schumacher
- **Freiburg University** - T. Bárger, H. Fischer, J. Franz, K. Königsmann, H. Schmidt
- **KEK** - T. Iijima
- **Kyoto University** - A. Ichikawa, K. Imai, Y. Kondo, K. Yamamoto, Y. Yosoi
- **Los Alamos National Laboratory** - P. Barnes, F. Merrill
- **Rutgers University** - R. Ransome
- **TRIUMF** - C. Davis, J. Doornbos
- **University of Kentucky** - V. Zeps
- **University of Kyoto-Sangyo** - F. Takeuchi
- **University of Manitoba** - J. Birchall, L. Gan, M. Landry, L. Lee, S. Page, D. Ramsay, V. Sum, W. van Oers
- **University of New Mexico** - B. Bassalleck, R. Stotzer

---

The existence and properties of 77 hypernuclei are intimately related to the H particle, a proposed six quark state (uuddss) and the question of strange matter and strangelets. If the H exists and is sufficiently bound, two 7s in a hypernucleus will fuse to form an H. The collaboration has built an experiment to form and detect 77 hypernuclei by stopping many more P than in any previous attempt.

Running of the experiment to date has primarily utilized a diamond target for high stopping rate of short-lived P. K at 1.8 GeV/c incident on a diamond target form P which stop in the diamond and K<sup>+</sup> which are detected in the spectrometer. Capture of P by carbon nuclei form 77 hypernuclei. A scintillating fiber array tracks hypernuclear decay products, and a large TOF array detects the

formation neutron. If H particles are formed, their decays can be detected.  $S = -2$  systems formed in the initial  $K^-$  interaction will also be studied.

### EXPERIMENT 890

Home Page • <http://ucla5.phy.bnl.gov/htdocs/e890/e890.html>

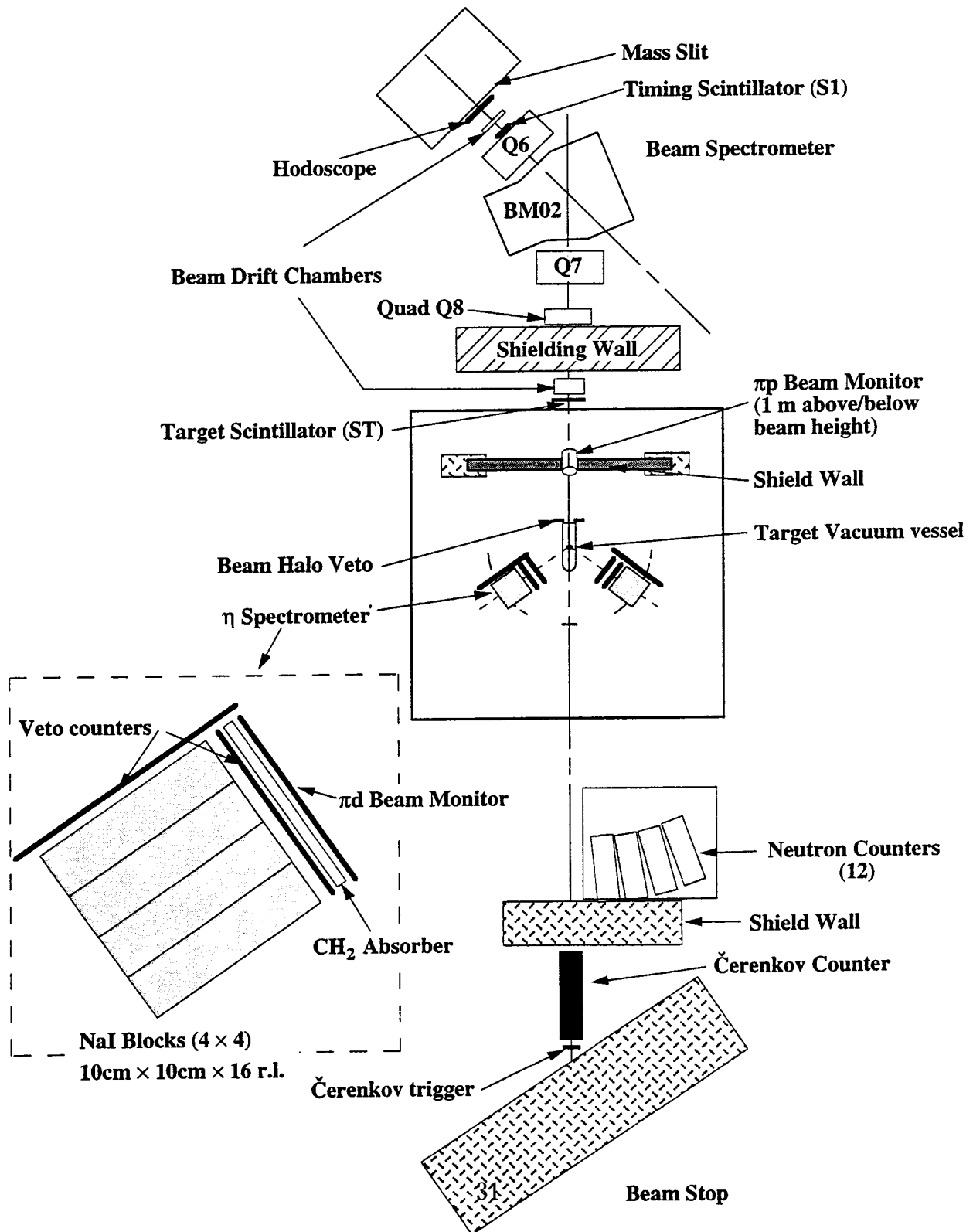

**EXPERIMENT 890 - A NEW TEST OF CHARGED SYMMETRY  
IN ETA PRODUCTION ON DEUTERIUM  
Spokesmen: B. M. K. Nefkens, R. E. Chrien, J. C. Peng**

- **Abilene Christian University** - M. Sadler, L. D. Isenhower
- **Brookhaven National Laboratory** - R. E. Chrien, R. Sawafta, R. J. Sutter
- **Forschungszentrum Jilich** - H. Seyfarth
- **George Washington University** - W. Briscoe, T. Morrison, Z. Papandreou
- **JINR, Dubna** - A. Efendiev
- **Los Alamos National Laboratory** - M. J. Leitch, J. C. Peng
- **Ruder Boskovic Institute** - M. Batinić, A. Marušić, I. Šlaus, A. Švarc
- **Petersburg Nuclear Physics Institute** - V. V. Abaev, V. S. Bekrenev, N. G. Kozlenko, S. P. Kruglov, A. B. Starostin
- **University of California-Los Angeles** - M. J. Clajus, S. McDonald, T. Moriwaki, B. M. K. Nefkens, J. W. Price, W. B. Tippens, D. B. White

---

The experimenters have measured the ratio of  $O^0$  production on deuterium by positive and negative pions over the momentum range from 640 MeV/c to 755 MeV/c. This range spans the onset of the  $S_{11}(1535)$  resonance, which has a very large branching ratio for  $O^0$  decay. The  $O^0$ s are observed by detection of the photons from the neutral decay of the  $O^0$  into two photons.

The measurement of this ratio is a direct test of the validity of charge symmetry in this unexplored domain of nuclear physics. Violations of the symmetry are to be expected because of  $B^0$ - $O^0$  mixing.

The experiments showed large asymmetries, ranging up to over 10% at the highest momentum pions.

A preliminary fit of the data to a model of  $O^0$  production which includes  $BE$ - $O^0$  mixing as the only adjustable parameter requires a value for the mixing angle of  $\sim 1$ - $2^\circ$ . This is the first direct evidence of  $BE$ - $O^0$  mixing in a nuclear environment.

The experiment also demonstrated the power of the AGS as a potent source of O mesons.

**EXPERIMENT 891**

Home Page • [http://www.phy.bnl.gov/e891/doc/www/welcome\\_891.html](http://www.phy.bnl.gov/e891/doc/www/welcome_891.html)

---

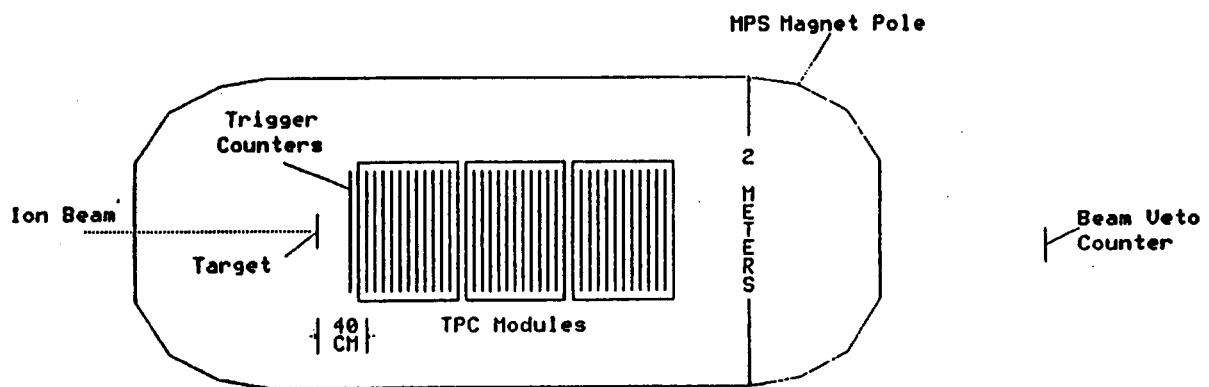

**EXPERIMENT 891 - A SEARCH FOR QUARK MATTER (QGP)  
AND OTHER NEW PHENOMENA UTILIZING AU-AU COLLISIONS AT THE AGS  
Spokesmen: E. D. Platner**

- **Brookhaven National Laboratory** - S. E. Eisenstein, A. Etkin, K. J. Foley, R. W. Hackenburger, R. S. Longacre, W. A. Love, A. C. Saulys
- **City College of New York** - C. S. Chan, E. Efstathiadis, M. A. Kramer, S. J. Lindenbaum \*, K. Zhao, Y. Zhu
- **Rice University** - S. Ahmad, B. E. Bonner, J. A. Buchanan, J. M. Clement, G. S. Mutchler, E. D. Platner
- **University of California, Berkeley** - J. Marx, L. Schroeder

---

A program is underway to study Au-Au collisions at the AGS by measuring the angles and momenta of charged tracks,  $K^0$ 's and  $\gamma$ 's using the TPC's and trigger detectors from E810. In order to handle the higher track multiplicities produced by Au beams, a modified geometric arrangement of the TPC modules is used. This program allows the experimenters to look for anomalous behavior in rapidities (or pseudorapidities), multiplicity, strangeness enhancements,  $P_z$  ( $E_z$ ), energy flow; possibly observe Hanbury-Brown and Twiss effects and other new phenomena. These observations are on an event-by-event basis so that particularly interesting classes of events can be selected and added together to search for new effects (like strangelets) implying a QGP or other new states of matter in a manner which tends to maximize signal-to-background ratios.

\* Also associated with Brookhaven National Laboratory

## EXPERIMENT 892

Home Page • <http://www/ags.bnl.gov/~e892/>

---

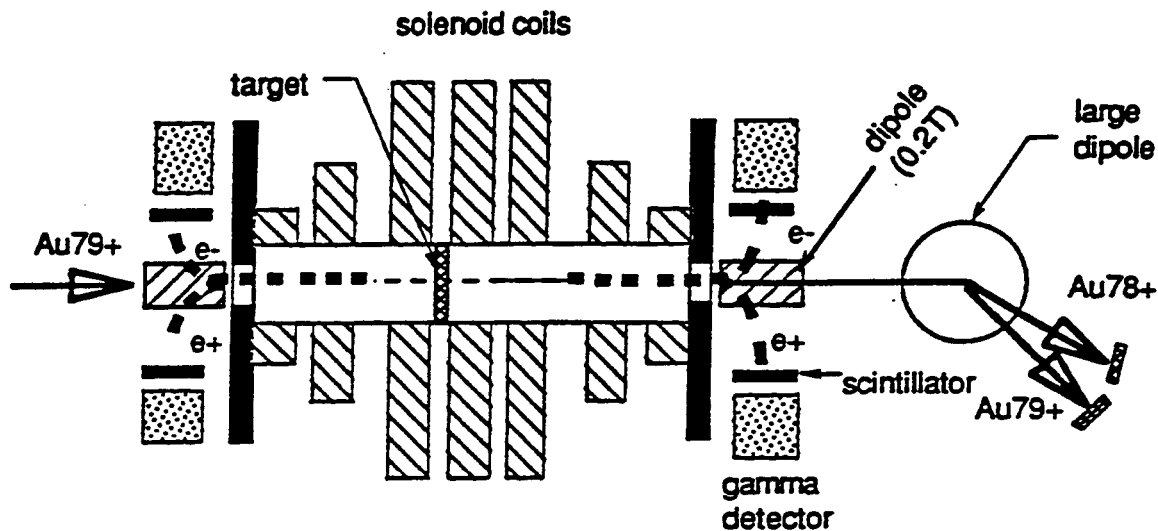

Schematic diagram of the apparatus. The adiabatically decreasing solenoid field (shown schematically by the coil height) transports and focuses the positrons. Small dipoles at either end deflect the positrons and electrons into the scintillator detectors. These detectors measure the positron energy and, from time of flight, determine the emission angle of the positron. Positrons are verified by the 511 keV annihilation radiation detected in the gamma detectors. A large dipole magnet(s) located downstream from the APS separates the charge states of the emerging ions.

**EXPERIMENT 892 - CAPTURE FROM PAIR PRODUCTION**  
**Spokesman: H. Gould**

- **Lawrence Berkeley Laboratory** - A. Belkacem, N. Claytor, T. Dinneen, B. Feinberg, H. Gould

---

The experiment measures the cross section for capture from pair production and free pair production of 10 GeV/n Au<sup>79+</sup> on Au collisions. This provides the first measurement of capture from pair production at energies above the 1 GeV/n region. The results are essential to understand the process, to guide ongoing efforts, to develop a nonperturbative theory, and to supply important data for the operations of RHIC. Capture from pair production is the process in which an electron-positron pair is produced by the transient electromagnetic field from a relativistic heavy-ion atomic collision (no nuclear contact) and the electron emerges bound to the projectile ion. It is unique because it is the only recombination process in which the cross section *increases* with energy at relativistic energies. At sufficiently high energies it is predicted to become the dominant re-combination mechanism.

***EXPERIMENT 893***

***Home Page • <http://www.dias.ie>***

---



Beam: B1  
Status: Complete FY 1996  
Hours Approved: 10/1

**EXPERIMENT 893 - TEMPERATURE/ZENITH ANGLE CALIBRATION  
OF POLYCARBONATE TRACK DETECTORS  
Spokesman: A. Thompson**

**Dublin Institute for Advanced Studies**

---

This experiment proposes to measure the track response of polycarbonate track detectors to relativistic Au ions at -20C and to investigate the isotropy of track response to Au at the same energy. This is a continuation of a program to calibrate polycarbonate SSNTD systems and to optimize their resolving power with special reference to the long term exposure which took place during the NASA LDEF Mission.

**EXPERIMENT 895**

**Home Page • [http://cnr2.kent.edu/~ e895/](http://cnr2.kent.edu/~e895/)**

---

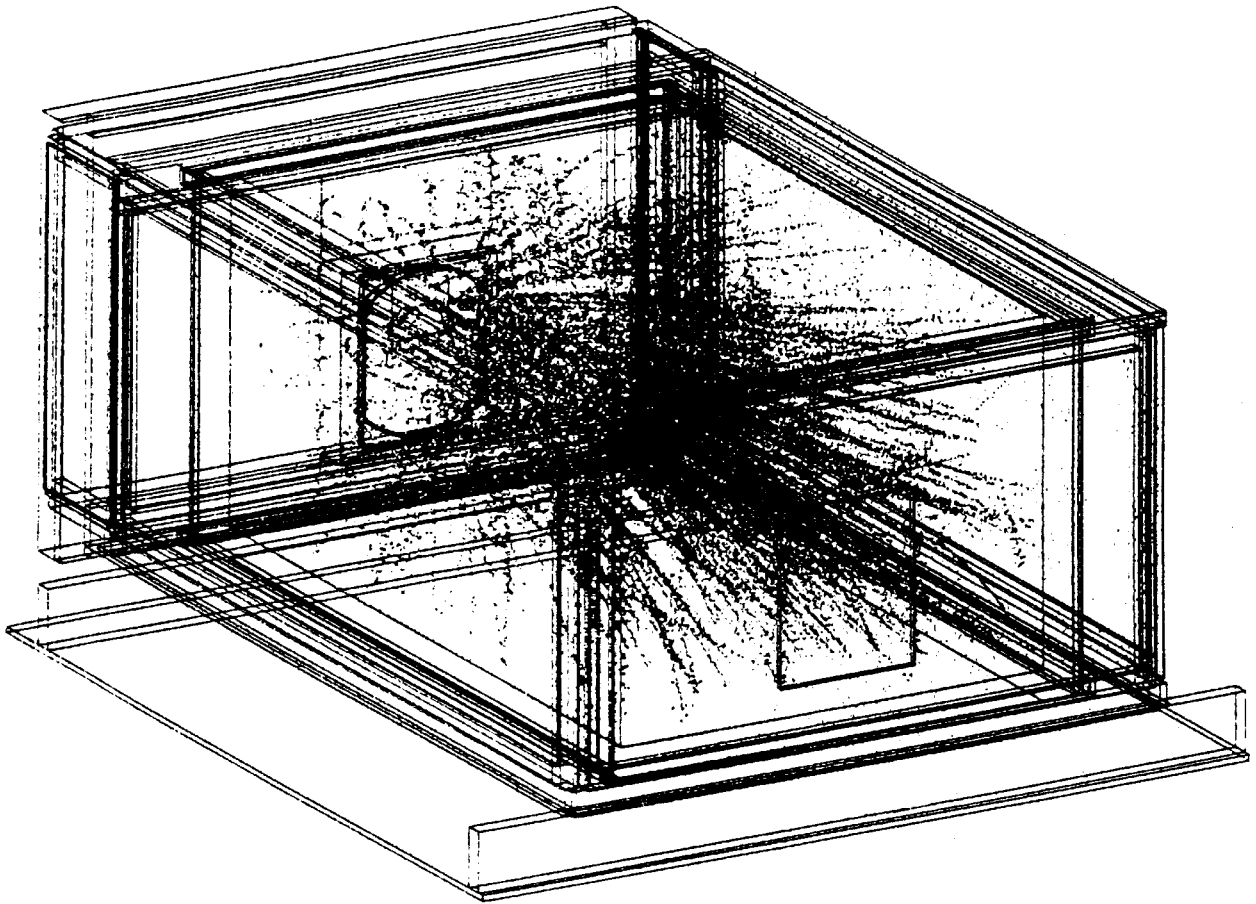

**Gold Event - TPC**

**EXPERIMENT 895 - EXCLUSIVE STUDY OF NUCLEAR COLLISIONS AT THE AGS**  
**Spokesman: G. Rai**

- **Brookhaven National Laboratory** - S. Gushue
- **Carnegie-Mellon University** - M. Kaplan, Z. Milosevich, J. Whitfield
- **Columbia University** - B. Cole
- **Harbin Institute of Technology** - L. Huo, Y. M. Liu, W. N. Zhang
- **Kent State University** - M. Justice, D. Keane, H. Liu, S. Panitkin, S. Wang, R. Witt
- **Lawrence Berkeley National Laboratory** - D. Best, T. Case, K. Crowe, G. Odyniec, D. Olson, G. Rai, H. G. Ritter, L. Schroeder, N. Stone, J. Symons, T. Wienold
- **Ohio State University** - A. Das, M. Lisa, R. Wells
- **Purdue University** - A. Hirsh, E. Hjort, M. Gilkes,\* N. Porile, B. Srivastava, R. Scharenberg
- **State University of New York at Stony Brook** - N. Ajitanand, J. Alexander, P. Chung, R. Lacey, R. McGrath, C. Pinkenburg
- **University of Auckland** - D. Krofcheck
- **University of California-Davis**  
P. Brady, W. Caskey, D. Cebra, J. Chance, J. Draper, M. Heffner, J. Romero

---

The experimenters are carrying out a systematic and exclusive measurement of the energy (2-10 A GeV) and mass dependence of particle production, correlations, and collective flow effects in Au+ Au collisions. They seek to determine the highest compression achievable in nuclear matter and to study its properties and they will search for evidence for an exotic Equation of State, that is, new physics such as Resonance Matter, Exotica, and QGP. The experimenters are also interested in signatures of critical phenomena in dilute nuclear matter.

It is proposed to measure the four-momentum of light mass particles ( $B^\pm$ ,  $K_s^0$ ,  $K^\pm$ ,  $\gamma$ , n, p, d,  $^3\text{He}$ ,  $^4\text{He}$ ,  $^6\text{He}$ , and the isotopes of Li and Be), projectile fragments from  $Z = 6$  to  $Z = 79$ , and anti-proton production. The majority of the data will be acquired, on an event by event basis, from a state-of-the-art Time Projection Chamber

(EOSTPC) built and used at LBL by the E0S collaboration. The TPC provides continuous tracking, almost 4 $\pi$  acceptance and particle identification for the light mass particles.

\* Deputy at the AGS

### **EXPERIMENT 896**

Home Page • [http://h0h03.e896.bnl.gov/~bnl896/home\\_e896.html](http://h0h03.e896.bnl.gov/~bnl896/home_e896.html)

---

## BNL-AGS E896 EXPERIMENTAL LAYOUT

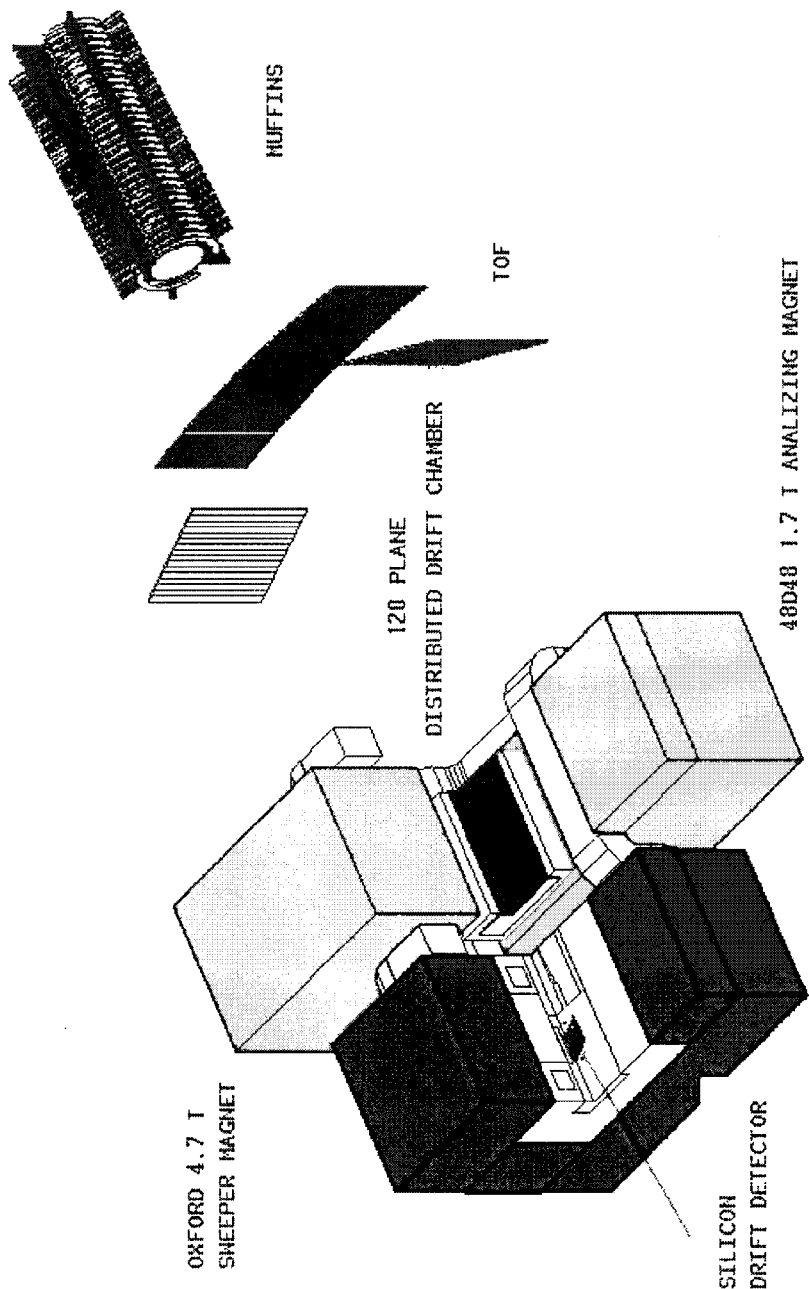

**EXPERIMENT 896 - A PROPOSAL TO THE BNLAGS:  
TO SEARCH FOR A SHORT-LIVED  $H_0$  DI-BARYON, SHORT-LIVED STRANGE MATTER,  
AND TO INVESTIGATE HYPERON PRODUCTION IN 11.6 A GEV/C AUAU COLLISION  
Spokesmen: H. Crawford and T. Hallman**

- **Brookhaven National Laboratory** - W. Christie, R. Debbé, T. Hallman, T. Ljubicic, R. Longacre, D. Lynn, J. Mitchell, E. Mogavero, A. Saulys
  - **Carnegie-Mellon University** - C. Brown, M. Kaplan, P. Karol, Z. Milosevich, J. Whitfield
  - **CERN** - P. Sonderegger
  - **Johns Hopkins University** - L. Madansky
  - **Lawrence Berkeley Laboratory** - L. Greiner, P. Lindstrom, J. Marx, I. Sakrejda
  - **NASA-Goddard Space Flight Center** - J. W. Mitchell
  - **Ohio State University** - T. Humanic, I. Kotov, G. LoCurto, E. Sugarbaker
  - **Rice University** - B. Bonner, M. Gupta, K. Kainz, W. Llope, G. Mutchler, E. Platner, C. Stokely, H. Themann, P. Yepes
  - **Space Science Laboratory** - M. Bennett, H. Crawford, M. Cronqvist, J. Engelage, M. Flores, L. Greiner, E. Judd, G. Visser
  - **Wayne State University** - R. Bellwied, Y. Guo, J. Hall, S. Nehmeh, S. Pandey, J. Sheen, J. Takahashi, K. Wilson
  - **Yale University** - S. Kumar, F. Rotondo, N. Smirnoff
  - **University of California-Los Angeles** - H. Huang, G. Igo, S. Kelly, S. Trentalage
  - **University of Catania** - S. Albergo, D. Boemi, Z. Caccia, G. Cina, S. Costa, A. Insolia, R. Potenza, G. Russo, A. Tricoma, C. Tuve
  - **University of Michigan** - R. Welsh
- 
- **University of Texas-Austin** - G. Hoffman, P. Jensen, S. Paganis, P. Riley, J. Schambach, J. Tang

The experiment is a search for the  $H_0$  di-baryon and for new states of nuclear matter produced in nucleus-nucleus (AA) collisions at the AGS. The experiment enhances the existing AA program by extending the search into regions of shorter lifetime and complements the existing double-strangeness-exchange program by offering access to a new, more probable doorway channel, the coalescence of two  $\Lambda$ 's into a bound di- $\Lambda$ . The detector is capable of unambiguously identifying the topological signature of unstable particle decays as well

as the rigidity of each particle produced, affording a sensitive search for new metastable states and investigation of the properties of known strange particles such as the  $\Lambda$  polarization and  $\Sigma$  potential.

**EXPERIMENT 898**

Home Page • [http://bnlstb.bio.bnl.gov/www\\_root/webdocs/nasa/nasapage.html](http://bnlstb.bio.bnl.gov/www_root/webdocs/nasa/nasapage.html)

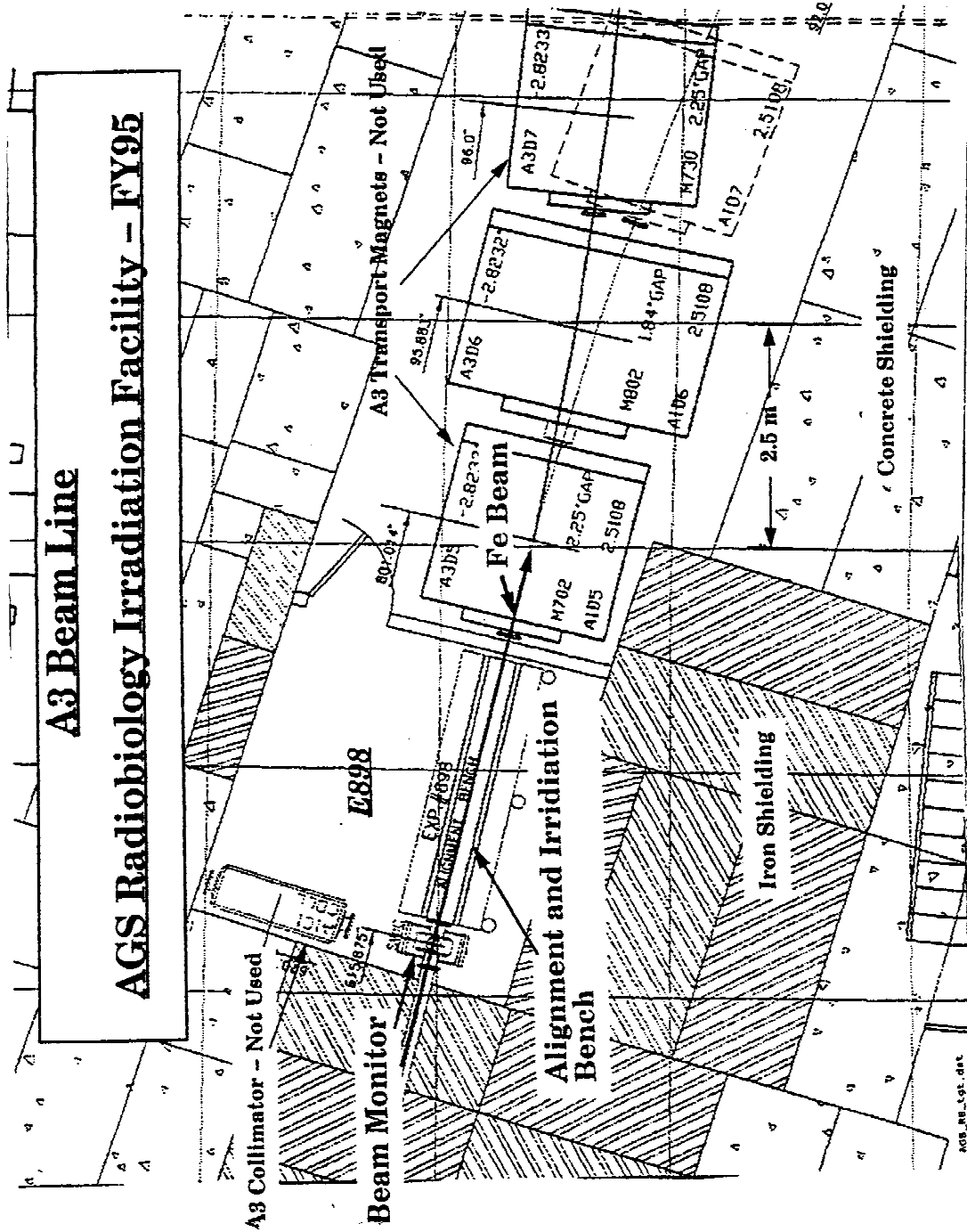

**EXPERIMENT 898 - RADIOBIOLOGY AND BIOPHYSICS WITH  
HIGH ENERGY HEAVY IONS  
Spokesmen: J. Miller, A. Kronenberg, G. A. Nelson**

- **Bemidji State University** - A. L. Lindgren
- **Brookhaven National Laboratory** - B. M. Sutherland, M. E. Vazquez
- **Colorado State University** - J. T. Lett, C. Waldren
- **Columbia University** - T. K. Hei
- **Georgetown University Medical Center** - T. J. Jorgensen
- **Jet Propulsion Laboratory** - G. A. Nelson
- **Lawrence Berkeley Laboratory** - M. H. Barcellos-Hoff, P. Cooper, A. Kronenberg, J. Miller
- **Los Alamos National Laboratory** - D. J. Chen
- **NASA Johnson Space Center** - T. C-h Yang
- **Pacific Northwest National Laboratory** - N. F. Metting
- **University of California** - L. H. Lutze-Mann
- **University of Maryland** - B. M. Rabin
- **University of Maryland School of Medicine** - E. K. Balder-Kubiczek

---

This experiment studies effects produced by heavy ions (principally 1 GeV/u<sup>56</sup>Fe) in a hierarchy of biological systems. The biological effects of densely ionizing radiation are studied for a number of genetic and cellular endpoints, constituting a broad range of quantifiable endpoints for the molecular to the whole animal level, in some cases including genetic responses over several generations. The biology experiments are supported by physics components designed to provide basic dosimetric information as well as the detailed characterization of the radiation field essential for the accurate interpretation of biological data.

E898 differs from a typical AGS experiment in that it actually consists of a number of more or less independent biology and physics experiments. The list of experiments and PI's may vary from year

to year. Please contact Dr. Marcelo Vazquez (BNL x 3443) for a list of investigators for 1995-1996.

***EXPERIMENT 900***

***Home Page • <http://www.iucf.indiana.edu> (click on Research/Nuclear Physics/ISIS)***

---



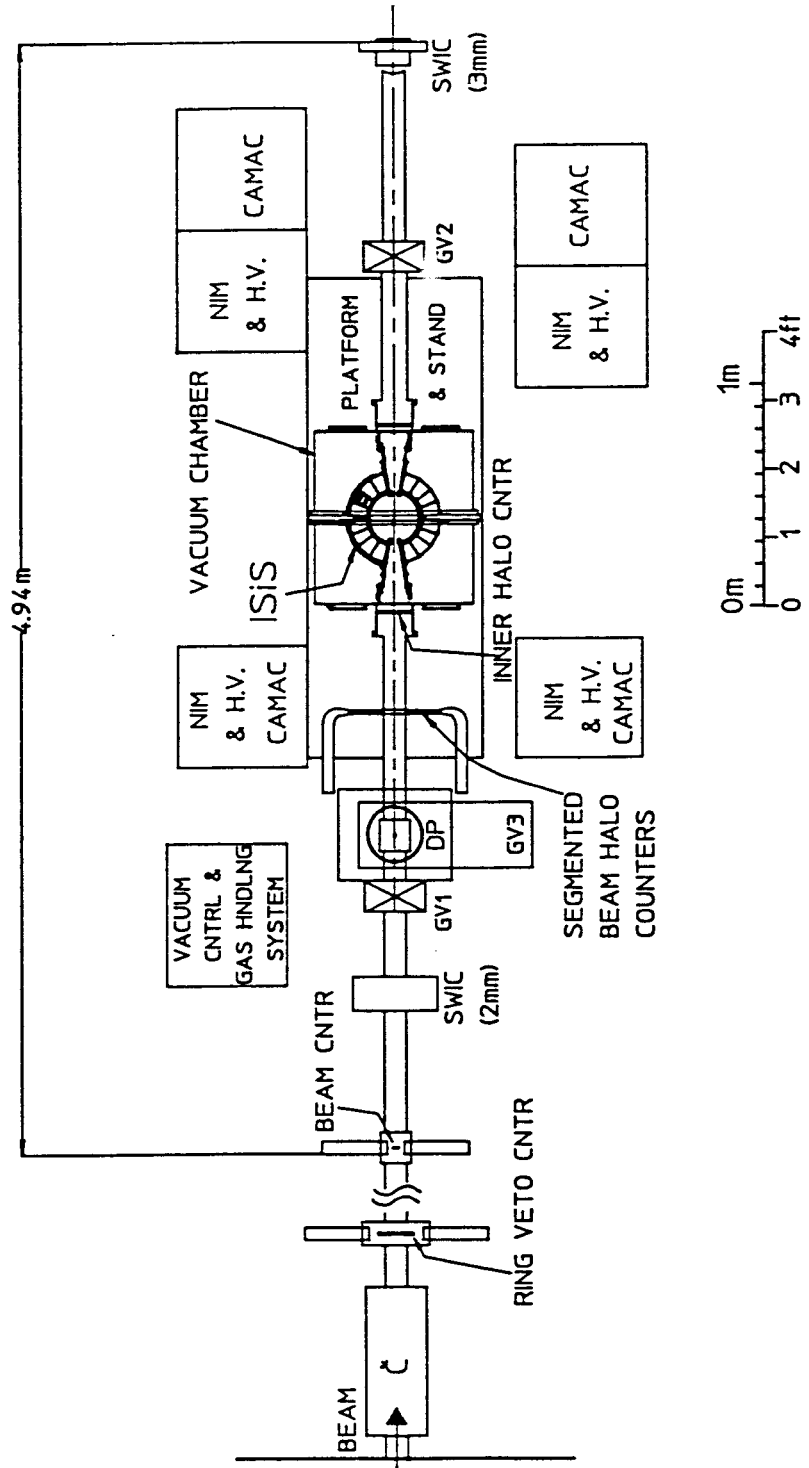

ISIS LAYOUT  
 AGS:A1 LINE  
 (plan view)

VME/CPU CAMAC  
 TRIGGER CAMAC

**EXPERIMENT 900 - ENERGY DISSIPATION AND MULTIFRAGMENTATION IN  
H + A REACTIONS BETWEEN 2 AND 24 GeV/c  
Spokesmen: K. Kwiatkowski and V. E. Viola**

- **Argonne National Laboratory** - B. Back
- **Brookhaven National Laboratory** - S. Gushue, L. P. Remsberg
- **Indiana University** - W.-Ch Hsi, K. Kwiatkowski, T. Lefort, V. E. Viola, N. R. Yoder
- **Los Alamos National Laboratory** - D. S. Bracken, K. B. Morley
- **Simon Fraser University** - R. Korteling
- **Texas A&M University** - F. Gimeno-Nogues, E. Ramakrishnan, D. Rowland, S. J. Yennello
- **Warsaw University** - L. Pienkowski
- **University of Maryland** - H. Breuer

---

Exclusive studies of target fragmentation in 2 - 24 GeV/c hadron ( $p$ ,  $\bar{p}$  and  $B^-$ )-induced reactions have started. Measurements are performed with the Indiana Silicon Sphere 4B detector array, capable of identifying H and He isotopes and  $Z = 3 - 20$  fragments for target rapidity ejectiles over a wide dynamic range. The primary physics objectives are twofold: (1) to improve the understanding of energy dissipation phenomena for central collisions in the  $h + A$  reaction at relativistic energies, and (2) to examine the decay modes of hot nuclear matter excited by simple hadron probes. The bombarding energy regime is chosen to overlap the region in which previous inclusive measurements at AGS have been interpreted in terms of a liquid-gas phase transition in hot finite nuclei. It is in this energy region that the excitation of  $\Delta$ ,  $N^*$  and higher resonances provide an effective means of dissipating projectile energy into internal excitation energy of the target nucleus. Thus, these data will place fresh constraints on the new generation of transport codes, as well as current models of multifragmentation. During the 1996 proton cycle, studies were successfully completed on the  $p + {}^{197}\text{Au}$  system at 6.0, 10.0, 12.0 and 14.6 GeV/c and  $B^- + {}^{197}\text{Au}$  at 5.0, 9.2 and 11.0 GeV/c. These measurements demonstrated an independence of energy deposition on projectile momentum and type for these reactions. In 1998 it is intended to measure the 7 GeV/c  $\bar{p} + {}^{197}\text{Au}$  reaction to search for enhanced energy deposition with antiproton beams.

**EXPERIMENT 903**  
**Home Page • [http:](http://)**



**EXPERIMENT 903 - A STUDY OF DOMAIN WALL PINNING IN IRRADIATED SAMPLES OF  
Nd<sub>2</sub>Fe<sub>14</sub>B**

**Spokesman: C. L. Snead and D. K. Finnemore**

- **Ames Laboratory** - P. C. Canfield, D. K. Finnemore, R. W. McCallum
- **Brookhaven National Laboratory** - C. L. Snead

---

The experimenters proposed to irradiate specimens of permanent-magnet materials so that the defect pinning of magnetic domain walls due to particle tracks can be evaluated.

An assortment of 10 samples ranging in thickness from 0.1 to 1.0 mm, each being about 1 mm square were used. The most interesting spacing for the damage tracks is in the range of 10 to 100 nm which implies irradiation to a dose of about  $10^{10}$  ions per  $\text{cm}^2$ . After the samples had been irradiated and characterized, annealing experiments were carried out to determine the microstructural changes induced by the annealing and the corresponding changes in domain wall pinning and performance characteristics of the material. Some samples were irradiated parallel to the c-axis and others at 45° to the c-axis.

The above has been completed.

**EXPERIMENT 904**  
**Home Page • [http:](#)**

---

**EXPERIMENT 904 - A STUDY OF COLUMNAR PINNING CENTERS  
IN HIGH  $T_C$  SUPERCONDUCTOR  
Spokesman: R. Weinstein**

- **Indiana University Cyclotron Facility** - C. C. Foster
- **Texas Southern University** - V. Obot
- **University of Houston** - J. Liu, D. Parks, Y. Ren, R-P Sawh, R. Weinstein

---

The experimenters will irradiate several stacks of YBCO tiles. The chemistry ( $Y_{1.7}Ba_2Cu_3Pt_{0.01}$ ) of these tiles, and their heat processing and oxygen annealing, are the best known at present for field trapping. One set of tiles will each be 20 mm in diameter and 8 mm thick. A stack of several such tiles will be used. As the Au ions penetrate,  $dE/dx$  increases. The ions will first form string-of-beads defects. This experiment will provide a string-of-beads test for the first time and will provide the materials to produce a trapped field magnet (TFM) of greater field than any previously achieved. The experimenters estimate that the field will be 5 Tesla at 77K, and 12.5 Tesla at 65K.

In addition, 4 sets of smaller tiles (3.7 mm in diameter and 2 mm thick) will also be irradiated. The small size of the tiles in these runs is suitable to VSM or SQUID measurement of the magnetic moment and hence  $J_c$ . These runs will provide a desirable cross check on the large scale analysis of  $J_c$  via trapped field. In order to get the same fluence as in the case of 20 mm diameter tiles, these smaller tiles require 1/16 of the beam x time. The 4 sets of tiles will be run at 4 values of fluence.

## EXPERIMENT 905

Home Page • <http://www.phy.bnl.gov/~bnlhyp/e905.html>

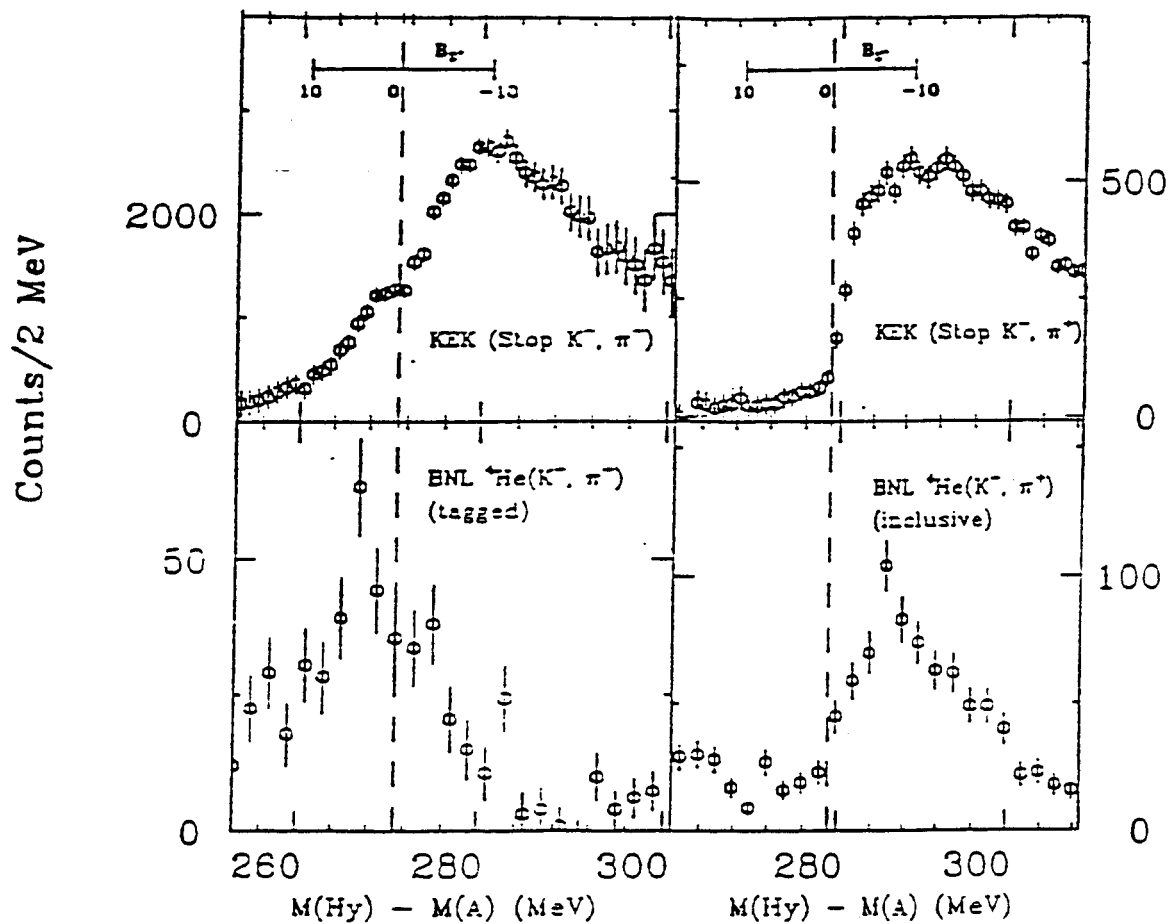

A comparison of the in-flight (BNL) observations of the G-structure in  ${}^4\text{He}$  and the stopped kaon experiments at KEK. In both sets, the structure is present in  $(K^-, B^-)$  reactions, but not for  $(K^-, B^+)$ .

**EXPERIMENT 905 - SEARCH FOR A G HYPERNUCLEAR BOUND STATE IN  $^4\text{He} (\text{K}^-, \text{A}^\pm)$  REACTIONS**  
**Spokesman: T. Nagae**

- **Brookhaven National Laboratory** - R. E. Chrien, A. Rusek, R. Sutter
- **George Washington University** - W. Briscoe
- **Hampton University** - W. Naing
- **INS-University of Tokyo**  
T. Fukuda, T. Miyachi, T. Nagae, J. Nakano, H. Oota, T. Tamagawa
- **North Carolina A&T** - R. Sawafta
- **Zagreb University** - M. Planinic
- **University of Houston** - T. Empl, E. V. Hungerford
- **University of North Carolina** - K. Johnston, C. Neerman
- **University of Tokyo** - R. S. Hayano, K. Kubota, Y. Shimizu, H. Tamura

---

The evidence for the existence of E (bound)-nuclei derives from three experiments: the first in a  $^4\text{He}$  bubble chamber at the AGS, the second at KEK with stopped  $\text{K}^-$  in  $^4\text{He}$ , and the third, BNL experiment E774. The purpose of E905 is to remeasure helium, using in-flight reactions to verify the existence of a bound state and to obtain the binding energy and width with high precision. This will be accomplished by making use of experience gained in BNL's E774 and E887 to get better control of systematic errors, suppress backgrounds due to electrons and muons and to obtain increased statistics. The precise measurement of the position and width of the postulated bound state may allow a definite allocation of the structure observed in these experiments to a bound state or to a threshold cusp, which is an alternative explanation. The precise measurement of the E-production cross sections in the bound and unbound regions will allow a choice between competing model explanations.



**EXPERIMENT 906**

Home Page • <http://www.phy.bnl.gov/~bnlhyp/t.html>

---

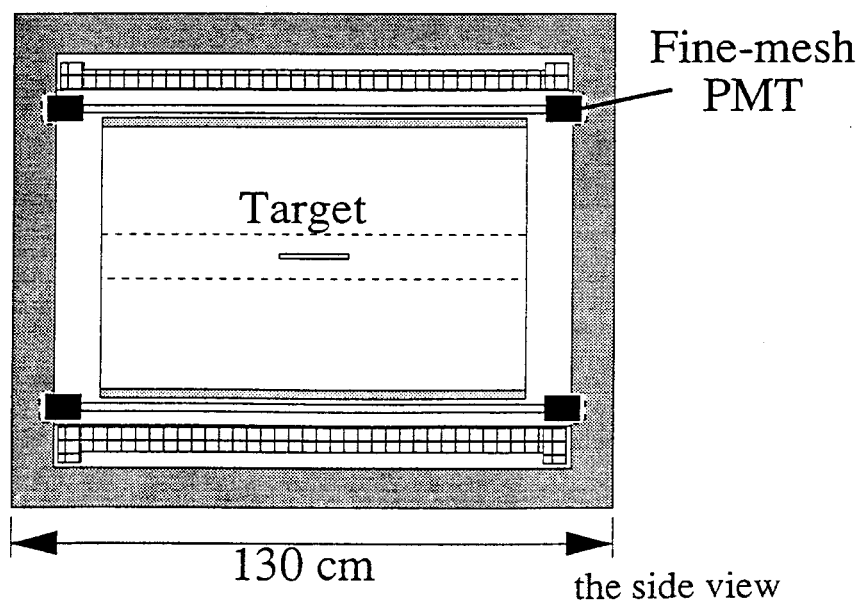
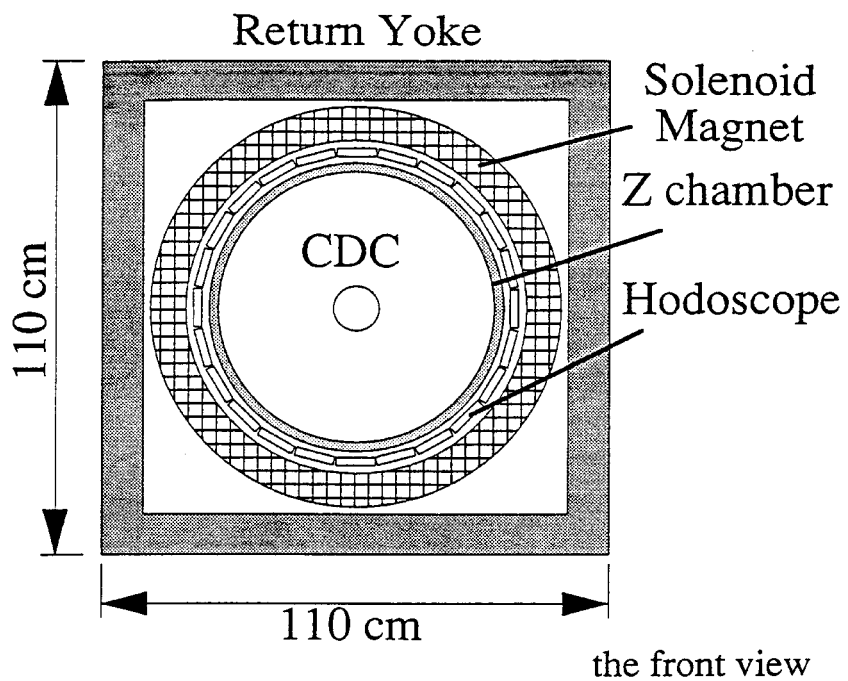

**EXPERIMENT 906 - EXPERIMENT TO DETECT DOUBLE-7 HYPERNUCLEI  
BY OBSERVING CHARACTERISTIC A - MESONIC DECAYS  
Spokesmen: T. Fukuda and R. E. Chrien**

- **Brookhaven National Laboratory** - R. E. Chrien, M. May, P. Pile, A. Rusek, R. Sutter
- **Carnegie-Mellon University** - A. Berdoz, D. Carm an, G. B. Franklin, B. P. Quinn,  
R. A. Schumacher
- **Gifu University** - M. Hanabata, K. Nakazawa
- **INR-Russia** - M. Prokvatilov, V. Rasin
- **INS-University of Tokyo** - J. Ahn, H. Akikawa, T. Fukuda, K. Kubota, T. Myuchi,  
T. Nagae, J. Nakano, K. Omata, H. Outa, M. Sekimoto, T. Tamagawa, H. Tamura,  
K. Tanida
- **Kyoto University** - K. Imai, K. Yamamoto, M. Yosoi
- **Kyoto-Sangyo University** - K. Okada, T. Kishimoto, F. Takeuchi
- **North Carolina A&T University** - R. Sawafta
- **Osaka University** - S. Ajimura, T. Kishimoto
- **Temple University** - E. Meziani
- **University of Freiburg** - H. Fischer, J. Franz, K. Konigsmann, H. Schmitt
- **University of New Mexico** - B. Bassalleck, H. Fischer, J. Lowe, D. M. Wolfe

---

The experimenters propose a new way to produce and to identify several hundred double-7 hypernuclei by observing two (successive) mesonic-decay pions with about 1.7 MeV resolution. The rate is larger by two orders of magnitude than other experiments done so far and will enable us to open a new spectroscopy of double-7 hypernuclei.

Double-7 hypernuclei will be produced at the ( $K^-$ ,  $K^+$ ) reaction point through multi-step processes and successive mesonic-decay pions will be detected by a cylindrical detector system and solenoidal magnetic spectrometer (CDS) surrounding the target. The 2 GeV/c kaon beam line and the same experimental setup used for E813 and E836 (with some minor modifications), will be used for this experiment.

**EXPERIMENT 907**

Home Page • <http://bart.phys.uh.edu/~mep/E907.html>

---

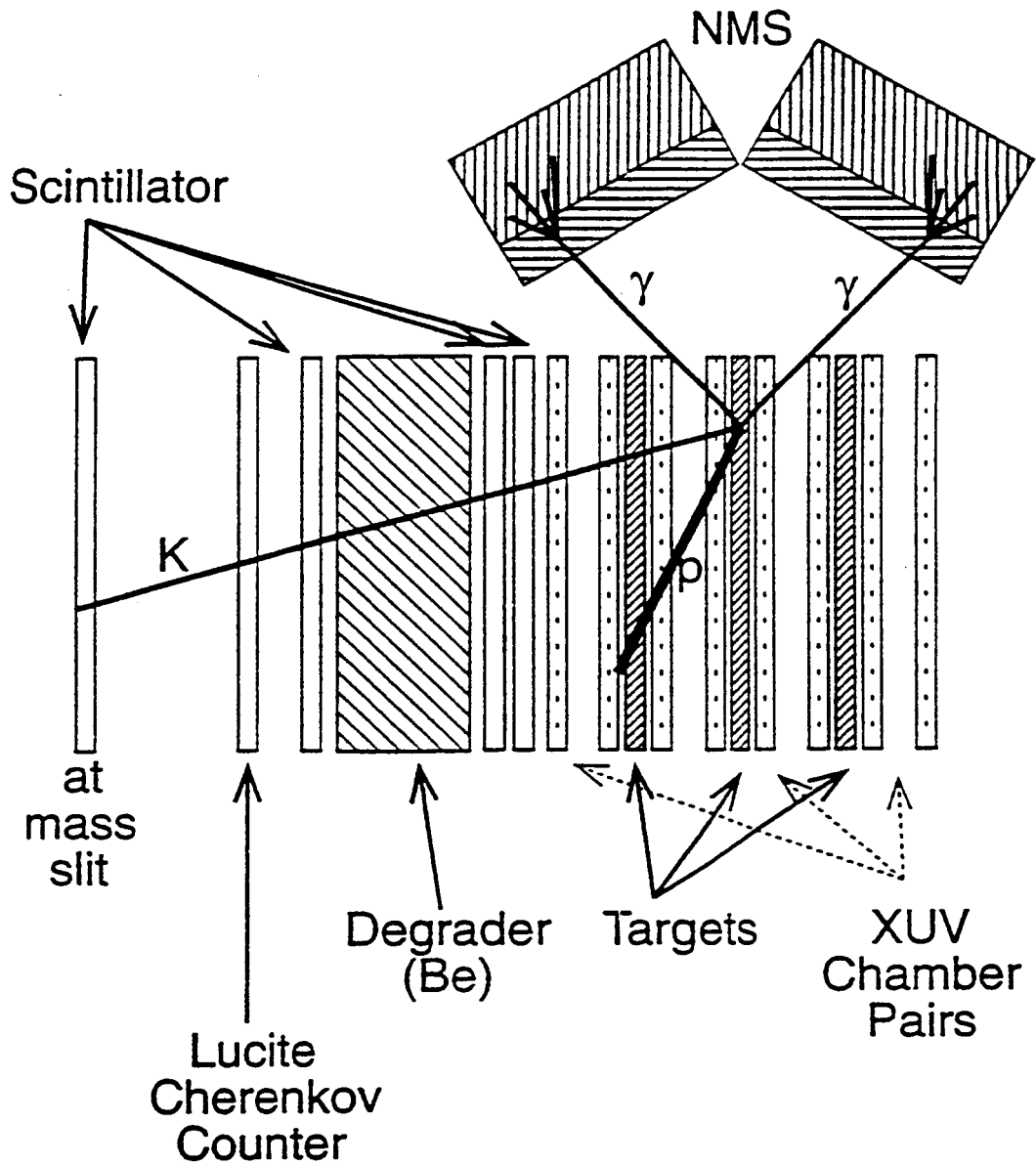

**Schematic layout of the experimental setup.**

**EXPERIMENT 907 - INVESTIGATION OF LIGHT HYPERNUCLEI USING THE  
( $K_{STOP}^-$ ,  $BE$ ) REACTION**

**Spokesmen: E. Hungerford and Jen-Chieh Peng**

- **Arizona State University** - J. R. Comfort, C. Gauland
- **Brookhaven National Laboratory** - R. E. Chrien, J. Gerald, M. May, P. H. Pile, A. Rusek, R. Sutter, W. B. Tippens
- **Carnegie-Mellon University** - G. B. Franklin, B. Quinn
- **CEBAF** - L. Tang
- **George Washington University** - W. Briscoe
- **Los Alamos National Laboratory** - J. Amann, D. Boudrie, C. Edwards, B. F. Gibson, C. Morris, J. O'Donnell, J.C. Peng, A. Thiessen
- **Louisiana Tech University** - M. Barakat, K. Johnston
- **North Carolina A&T** - R. Sawafta
- **R. Boskovic Institute** - I. Supek
- **Tohoku University** - O. Hashimoto
- **University of California at Los Angeles** - B. Nefkens
- **University of Colorado** - G. A. Peterson
- **University of Houston** - M. Ahmed, X. Cui, A. Empl, E. V. Hungerford, A. Lan, B. Mayes, L. Pinsky
- **University of Kentucky** - V. Zeps
- **University of Maryland** - P. G. Roos
- **University of Minnesota** - D. Dehnhard
- **University of Texas at Austin** - G. Glass, C. Fred Moore, H. Ward
- **University of Zagreb** - D. Androic, M. Furic, T. Petkovic, M. Planinic

---

The experimenters propose to use the combination of a multi-layer active target and the Neutral Meson Spectrometer (NMS) to detect  $B^0$ s in order to study hypernuclear physics. The reaction to be used is ( $K_{top}^-, BE$ ), with stopping  $K^-$  obtained from the LESB-II(C) beam line at the AGS. The NMS will be moved from LAMPF to BNL for this experiment.

# EXPERIMENT 909

Home Page • <http://ucla5.phy.bnl.gov/htdocs/e909/e909.html>

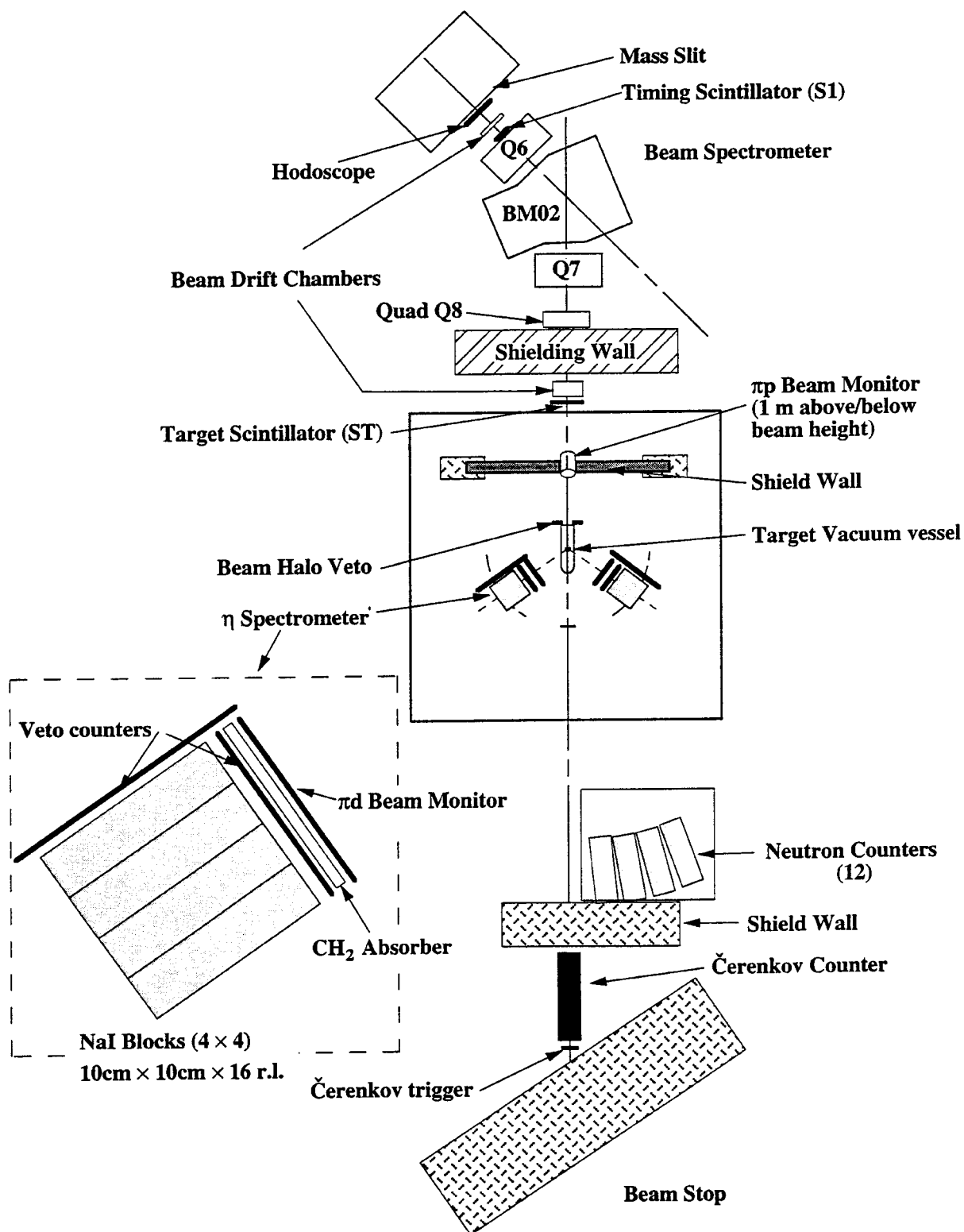

**EXPERIMENT 909 - ETA PRODUCTION AT THRESHOLD IN THE REACTIONS  
B<sup>-</sup> p 6 On and K<sup>-</sup> p 67 O  
Spokesmen: W. J. Briscoe and W. B. Tippens**

- **Abilene Christian University** - L. D. Isenhower, M. E. Sadler
- **Brookhaven National Laboratory** - S. Bart, R. E. Chrien, R. Sawafta, D. Sutter
- **George Washington University** - C. Bennhold, W. J. Briscoe, T. W. Morrison, Z. Papandreou, S. Philips, R. Pratt, J. Prokop,
- **Joint Institute for Nuclear Research-Dubna** - A. Efendiev
- **PNPI, Gatchina** - V. Abaev, V. Bekrenev, N. Kozlenko, S. Kruglov
- **Rudjer Boskovic Institute** - A. Marusic, I. Šlaus
- **University of California-Los Angeles** - M. Clajus, S. McDonald, T. Moriwaki, B. M. K. Nefkens, W. B. Tippens, D. White

---

The threshold for O production in the reactions B<sup>-</sup>p 6 On and K<sup>-</sup>p 67 O is close to the mass of the S<sub>11</sub>(N\*(1535) and S<sub>01</sub>(7\*(1670) resonances, respectively. The cross section for O production in both reactions is unexpectedly large as are other O threshold production cross sections. Better quality data, particularly angular distributions which are currently lacking, in both the K<sup>-</sup>p and B<sup>-</sup>p reactions are needed to understand the role of these resonances near the O threshold. There is a factor of four discrepancy in the determination of the ON scattering length and the O<sup>7</sup> scattering length is unknown due to a lack of precise threshold cross section data. New, precision data at threshold would allow better determinations of these scattering lengths.

The experimenters propose to measure total cross section, as well as angular distributions for O production in both of these reactions from threshold ( $P_B = 685$  MeV/c, and  $P_K = 723$  MeV/c) up to 760 MeV/c. The O particles are detected via the 2( decay mode using the improved O spectrometer currently in operation on the C8 beam line.

**EXPERIMENT 910**

Home Page • <http://nevis1.nevis.columbia.edu/heavyion/e910/>

---

Plan view of the proposed experiment

**EOS - pA Plan View**

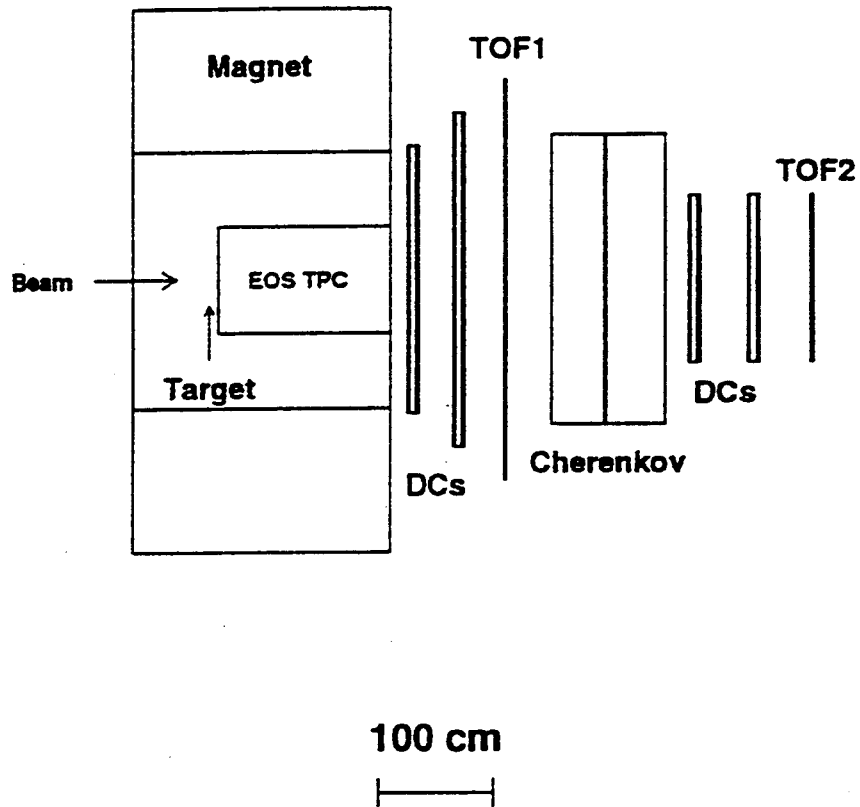

**EXPERIMENT 910 - A FACILITY TO STUDY PROTON-NUCLEUS AND HEAVY ION COLLISIONS  
USING A LARGE-ACCEPTANCE DETECTOR WITH PARTICLE IDENTIFICATION CAPABILITIES**  
**Spokesman: B. A. Cole**

- **Brookhaven National Laboratory** - R. Fernow, S. Gushue, H. Kirk, L. Remsberg, M. Rosati, Y. Torun
- **Columbia University** - I. Chemakin, B. A. Cole, H. Hiejima, M. Moulson, D. Winter, X. Yang, W. A. Zajc, Y. Zhang
- **Florida State University** - A. D. Frawley
- **Kent State University** - M. Justice, D. Keane
- **Lawrence Berkeley Laboratory** - G. Rai
- **Lawrence Livermore National Laboratory** - V. Cianciolo, M. Kreisler, M. N. Namboodiri, T. C. Sangster, R. Soltz, J. Thomas
- **State University of New York at Stony Brook** - M. Gilkes, R. L. McGrath
- **Yonsei University** - J. H. Kang, Y. H. Shin
- **University of Tennessee** - S. Mioduszewski, D. Morrison, K. Read, S. Sorensen
- **University of Tsukuba- Institute of Physics** - K. Kurita, Y. Miake

---

The experimenters are studying proton-nucleus (p-A) and heavy ion collisions at the AGS using a large-acceptance detector. The main focus of the experiment is measurement of strange particle production and a search for  $H^0$  dibaryon formation in p-A collisions. The strange-particle production measurements will provide data for comparison to recent measurements in heavy-ion collisions and also allow more detailed studies of the mechanisms that are responsible for strangeness enhancement in p-A and heavy-ion collisions. The main component of the proposed detector is the EOS TPC, a part of Exp. 895. The TPC will be augmented with downstream tracking, a high-resolution time-of-flight wall and a second-level trigger capable of triggering on kaons in the final state. The apparatus will provide a dedicated facility for the EOS TPC which would allow the detector to be employed during all modes of AGS running.



# EXPERIMENT 913

Home Page • [http://ucla5.phy.bnl.gov/htdocs/e913-914\\_new/e913-914.html](http://ucla5.phy.bnl.gov/htdocs/e913-914_new/e913-914.html)

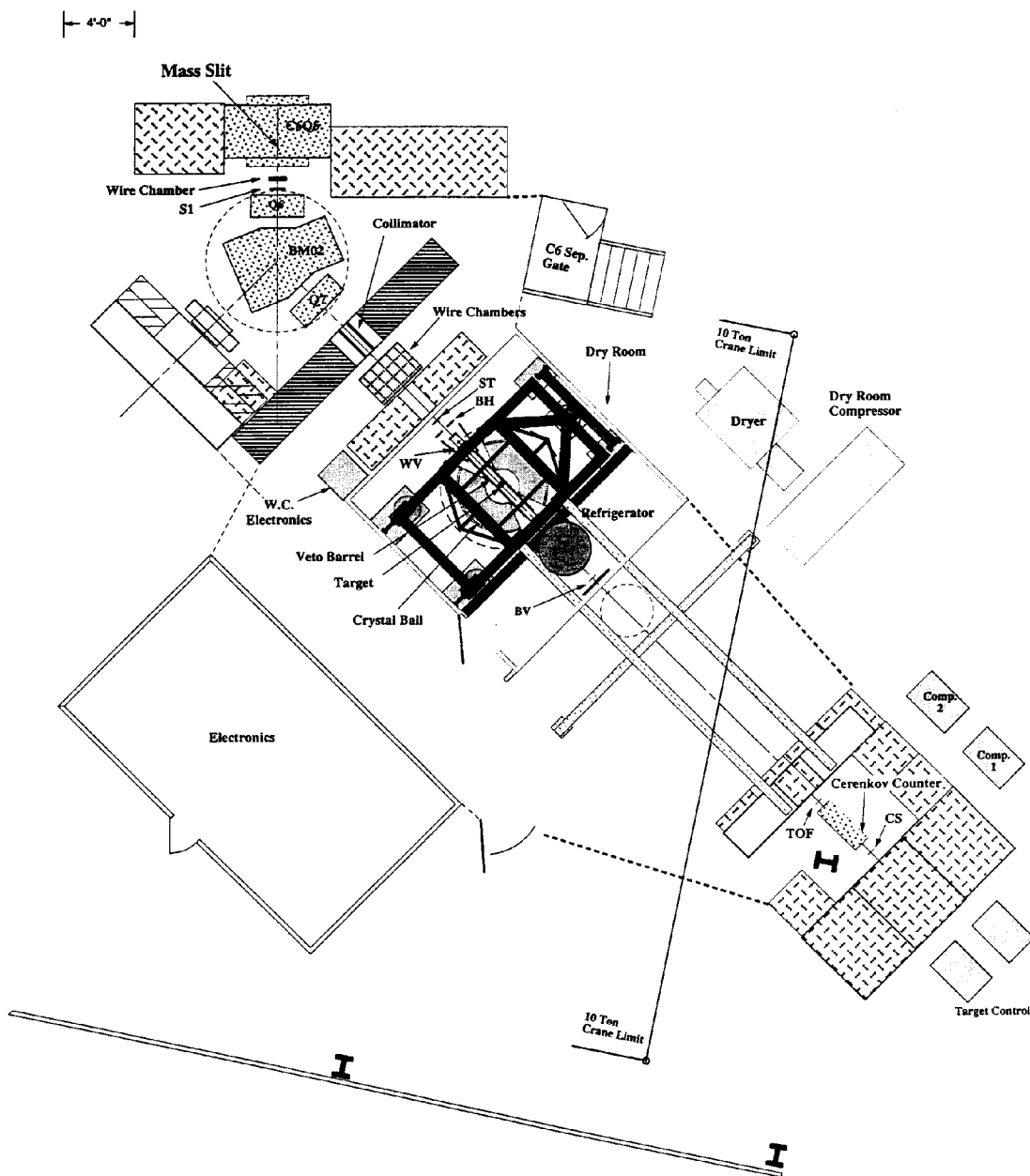

**EXPERIMENT 913 - BARYON SPECTROSCOPY WITH THE CRYSTAL BALL**  
**Spokesmen: M. E. Sadler and W. B. Tippens**

- **Abilene Christian University** - R. Bagga, B. Draper, J. Huddleston, D. Isenhower, Z. Mulkey, M. Sadler
- **Argonne National Laboratory** - T. Kasprzyk, H. Spinka
- **Arizona State University** - J. Comfort, K. Craig, A. Ramirez
- **Brookhaven National Laboratory** - T. Kycia
- **George Washington University** - W. J. Briscoe, A. Shafi
- **Kent State University** - D. M. Manley
- **Petersburg Nuclear Physics Institute-Gatchina** - V. Abaev, V. Bekrenev, S. Kruglov, A. Kulbardis, I. Lopatin, A. Starostin
- **Rudjer Boskovic Institute** - I. Šlaus, I. Supek
- **Valparaiso University** - A. Gibson, D. Grosnick, D.D. Koetke, R. Manweiler, P. Nord, S. Stanislaus
- **University of California-Los Angeles** - M. Clajus, S. McDonald, A. Marusic, B.M.K. Nefkens, M. Pulver, W. B. Tippens
- **University of Colorado** - J. Patterson, J. Peterson
- **University at Karlsruhe** - H. Staudenmaier
- **University of Regina** - N. Knecht, G. Lolos, Z. Papandreou

---

This is a comprehensive experimental program in baryon spectroscopy using the SLAC Crystal Ball detector to make precision measurements of total and differential cross sections for neutral final states in B

interactions using pion beams in the momentum range 0.4 - 1.9 GeV/c. The angular distributions of all the neutral final states such as (n, B<sup>0</sup>) are measured simultaneously. The purpose is to improve the mass, width, and neutral branching fractions for the N\* resonances in this energy region. The Crystal Ball detector is a nearly 4B multi-photon spectrometer which is used to analyze events by reconstructing the invariant mass and, in conjunction with the measured beam momentum, the missing mass of the produced ( rays.

# EXPERIMENT 914

Home Page • <http://ucla5.phy.bnl.gov/htdocs/e913-914/e913-914.html>

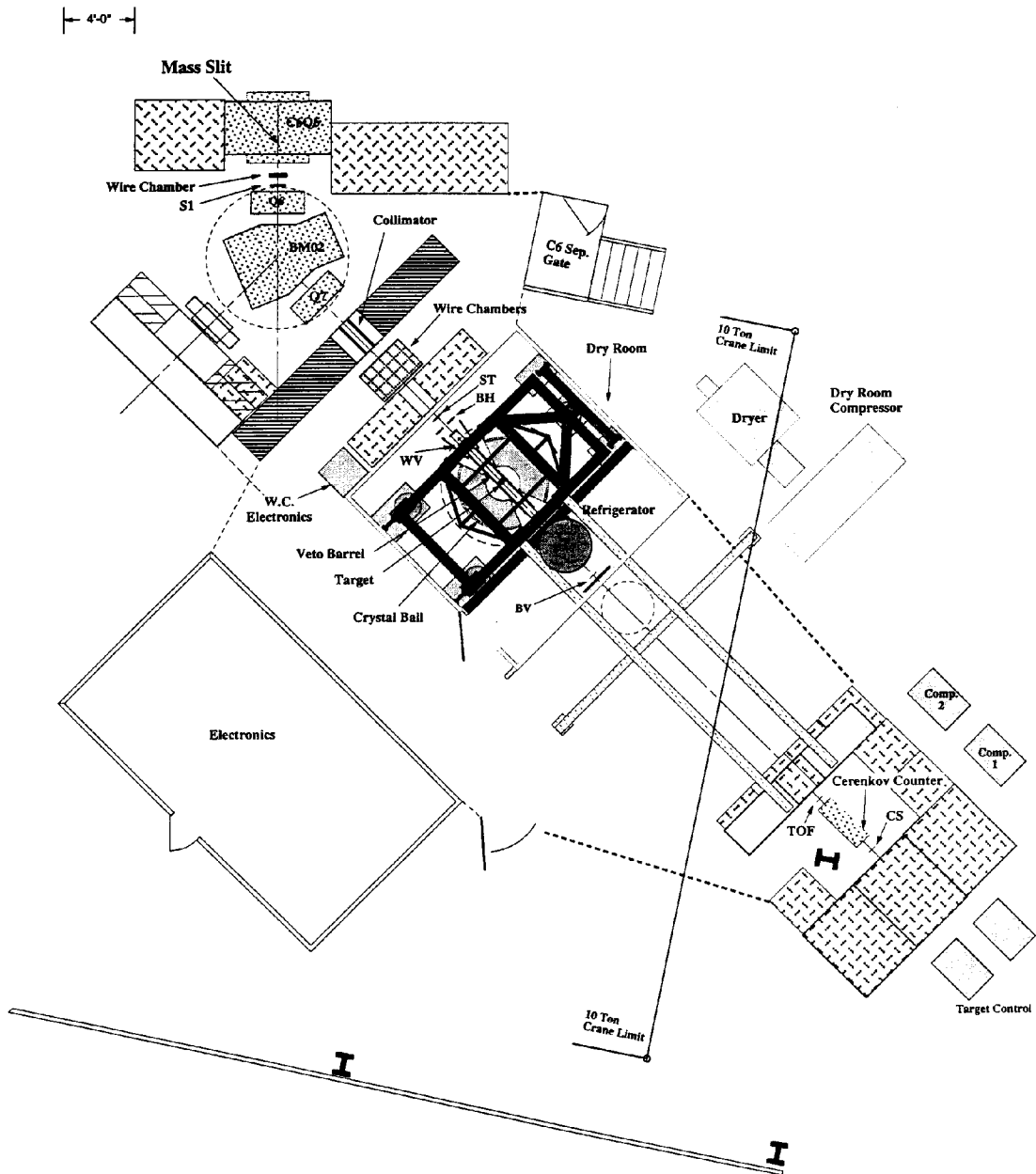

**EXPERIMENT 914 - NEUTRAL HYPERON SPECTROSCOPY**  
**Spokesmen: B.M.K. Nefkens, T. Kycia, S.P. Kruglov**

- **Abilene Christian University** - R. Bagga, B. Draper, J. Huddleston, D. Isenhower, Z. Mulkey, M. Sadler
- **Argonne National Laboratory** - T. Kasprzyk, H. Spinka
- **Arizona State University** - J. Comfort, K. Craig, A. Ramirez
- **Brookhaven National Laboratory** - T. Kycia
- **George Washington University** - W. J. Briscoe, A. Shafi
- **Kent State University** - D. M. Manley
- **Petersburg Nuclear Physics Institute-Gatchina** - V. Abaev, V. Bekrenev, S. Kruglov, A. Kulbardis, I. Lopatin, A. Starostin
- **Rudjer Boskovic Institute** - I. Šlaus, I. Supek
- **Valparaiso University** - A. Gibson, D. Grosnick, D.D. Koetke, R. Manweiler, P. Nord, S. Stanislaus
- **University of California-Los Angeles** - M. Clajus, S. McDonald, A. Marusic, B.M.K. Nefkens, M. Pulver, W. B. Tippens
- **University of Colorado** - J. Patterson, J. Peterson
- **University of Karlsruhe** - H. Staudenmaier
- **University of Regina** - N. Knecht, G. Lolos, Z. Papandreou

This experiment proposes to investigate the spectrum of  $\Sigma^*$  and  $\Sigma^*$  resonances via their neutral decays in the reactions:

$K^- p \Sigma^+ \Sigma^0$	600-1800 MeV/c ( $p_{lab}$ )
$K^- p \Sigma^+ \Sigma^0$	"
$K^- p \Sigma^+ \Sigma^0$	"
$K^- p \Sigma^+ \Sigma^0$	720-1800 MeV/c ( $p_{lab}$ )
$K^- p \Sigma^+ \Sigma^0$	600-1800 MeV/c ( $p_{lab}$ )
$K^- p \Sigma^+ \Sigma^0$	"
$K^- p \Sigma^+ \Sigma^0$	"
$K^- p \Sigma^+ \Sigma^0$	890-1800 MeV/c ( $p_{lab}$ )

Measurements of total and differential cross sections of these reactions will be made simultaneously over the full angular range, using the Crystal Ball multi photon spectrometer and a LH2 target. The Crystal Ball has a 94% solid angle coverage and good energy and angular resolution. The incident beam momentum is varied in steps of 25-50 MeV/c from 600 MeV/c in the C-line to the maximum momentum of 1.8 GeV/c in the D-line.

**EXPERIMENT 915**  
**Home Page • [http:](#)**

---

**EXPERIMENT 915 - Proposal for 11.4 A GeVAu Exposure at the AGS**  
**The Trek Collaboration**  
**Spokesman: A. Westphal**

- **Space Research Institute (IKI) - Moscow**
- **University of California at Berkeley - A. Westphal**

---

The Trek Collaboration proposes to use the 11.4 A GeVAu beam at the AGS to calibrate the large collector of the Trek experiment. Trek is a collaborative experiment consisting of the physicists at Berkeley and at the Space Research Institute in Moscow. Trek consists of two detectors. The small detector (0.09 m<sup>2</sup> in area) was mounted on an outside wall of the living quarters of the space station and has already been returned to earth for analysis. Its goal is to measure the isotopic abundances of iron-group elements in the galactic cosmic-rays. A large collector for ultraheavy galactic cosmic rays was mounted on the outside of the Kvant-2 module for the Mir Space Station to two cosmonauts in an EVA in June 1991. The goals of the large Trek collector are to resolve and measure the composition of both odd-Z and even-Z cosmic-ray nuclei from tin (Z = 50) through uranium (Z = 92) and to search for transuranic nuclei and exotic particles such as strangelets. The experimenters propose to calibrate the detectors with a highly relativistic gold beam at the AGS at the first opportunity after recovery.

**EXPERIMENT 916**  
**Home Page • [http:](#)**

---

**EXPERIMENT 916 - STUDY OF PROJECTILE FRAGMENTATION FOR  $^{197}\text{Au}$  IONS AT  $\sim 4\text{A GeV}$   
IN VARIOUS TARGETS  
Spokesman: Y. D. He**

- **University of California - Berkeley** - Y. D. He, P. B. Price

---

This is a small-scale experiment with  $^{197}\text{Au}$  ions at  $\sim 4\text{A GeV}$ . We exposed 10 BP-1 glass detectors interleaved with targets ranging from C to Pb to a defocused low intensity beam over an area of  $5\text{ cm} \times 5\text{ cm}$  at a density of  $1200 \pm 200\text{ cm}^{-2}$ . Using our automated scanning system, the charge resolution from one single measurement is found to be  $\sim 0.14$  charge unit. The charge resolution for beam particles and projectile fragments obtained from 5 plates of detectors is  $\sim 0.06$  charge unit (see figure). This charge resolution is more than adequate to identify fragments and hence to measure cross sections for charge-changing interactions. With this experiment, we hope to accomplish the following:

1. **Fragmentation Study:**

We will study nuclear reactions that we have previously studied at  $\sim 1\text{A GeV}$  at BEVALAC and  $\sim 11\text{A GeV}$  at AGS. In particular, we will measure cross sections at  $\sim 4\text{A GeV}$  for fragmentation both nuclear and electromagnetic, for charge pickup reaction, and for other processes in collisions of  $\sim 4\text{A GeV}$  on various targets. We hope to establish the energy dependence of these cross sections, which may enable us to understand the physics in peripheral collisions of relativistic heavy ions.

2. **Detector Response Study:**

Another interesting topic is the study of the response of BP-1 glass detectors to relativistic heavy ions with different energies. We have previously established the dependence of the detector response on charge  $Z$  for a given velocity  $\beta c$ . The response is empirically known to be a complicated function of  $(Z/\beta)^2$ , to a good approximation, for a limited range of  $\beta$  tested. However, the dependence of the response on Lorentz factor  $\gamma$  for a wide range of  $\beta$  remains unknown. With this experiment, we expect to study the dependence of the detector response on  $\beta$  for a given  $Z$ . This set of data will permit an interesting examination of the dependence of restricted energy loss on  $\gamma$  (in addition to  $(Z/\beta)^2$  term).



# EXPERIMENT 917

Home Page • <http://phyun0.ucr.edu/~e917/>

---

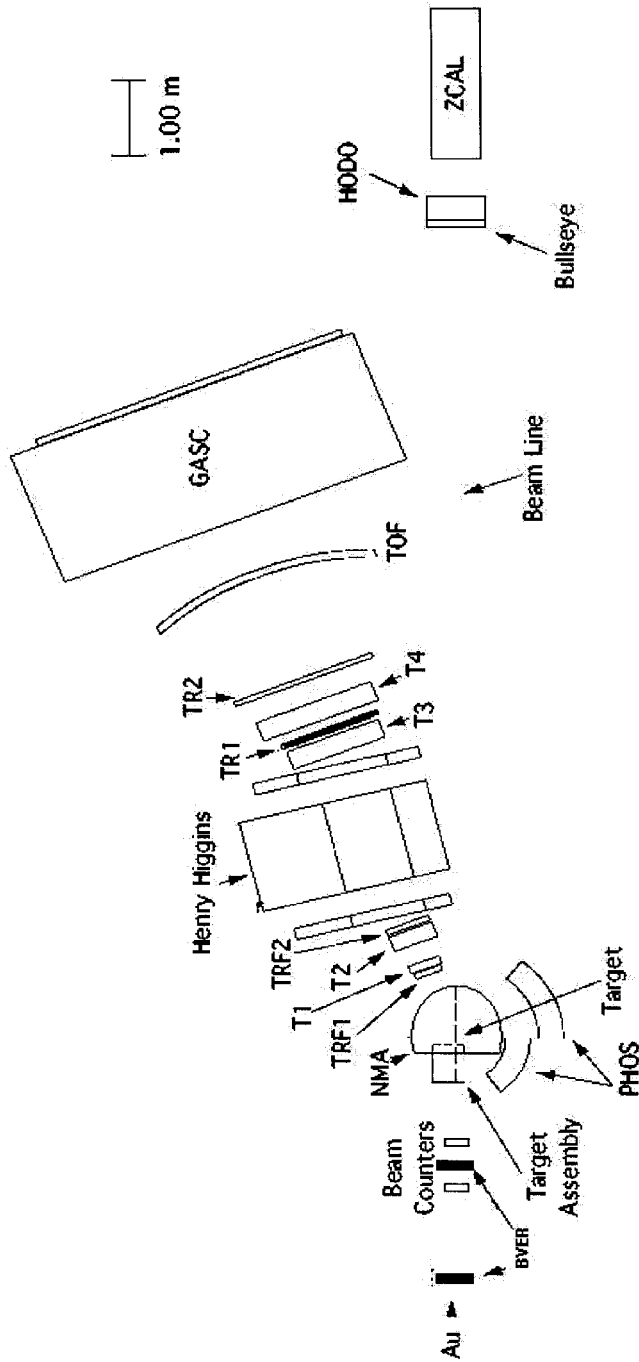

**EXPERIMENT 917- STUDIES OF HIGH DENSITY BARYON MATTER USING RARE PROBES**  
**Spokesmen: R. Seto and A. Mignerey**

- **Argonne National Laboratory** - B. Back, A. Gillitzer, w. Henning, d. Hofman, V. Nanal, A. Wuosmaa
- **Brookhaven National Laboratory** - Y. Y. Chu, J. Cumming
- **Columbia University (Nevis Labs.)** - C. Y. Chi
- **Massachusetts Institute of Technology** - J. Dunlop, G. Heintzelman, C. Ogilvie, G. Stephans, H. Yao
- **Yonsei University** - J. H. Kang, E.-J. Kim, S. Y. Kim, Y. Kwon
- **University of California-Riverside** - J. Chang, W. Chang, W. Elderege, S. Y. Fung, R. Seto, H. Wang, H. Xiang, G. Xu, C. Zou
- **University of Illinois - Chicago** - R. Betts, C. Conner, R. Ganz, B. Holtzman, D. McLeod
- **University of Maryland** - H. Britt, E. Garcia, A. Mignerey, A. Ruangma, D. Russ, J. Stankas
- **University of Rochester** - R. Pak, F. Wolfs

---

The proposed experiment will study the physics of the high-baryon density matter being created in Au-Au collisions at the AGS. through the systematic measurement of short lived vector mesons and baryons, the measurement of strange anti-baryons and anti-protons, and high statistics HBT studies.

**EXPERIMENT 919**

Home Page • [http://bnkfb.bio.bnl.gov/www\\_root/webdocs/nasa/nasapage.html](http://bnkfb.bio.bnl.gov/www_root/webdocs/nasa/nasapage.html)

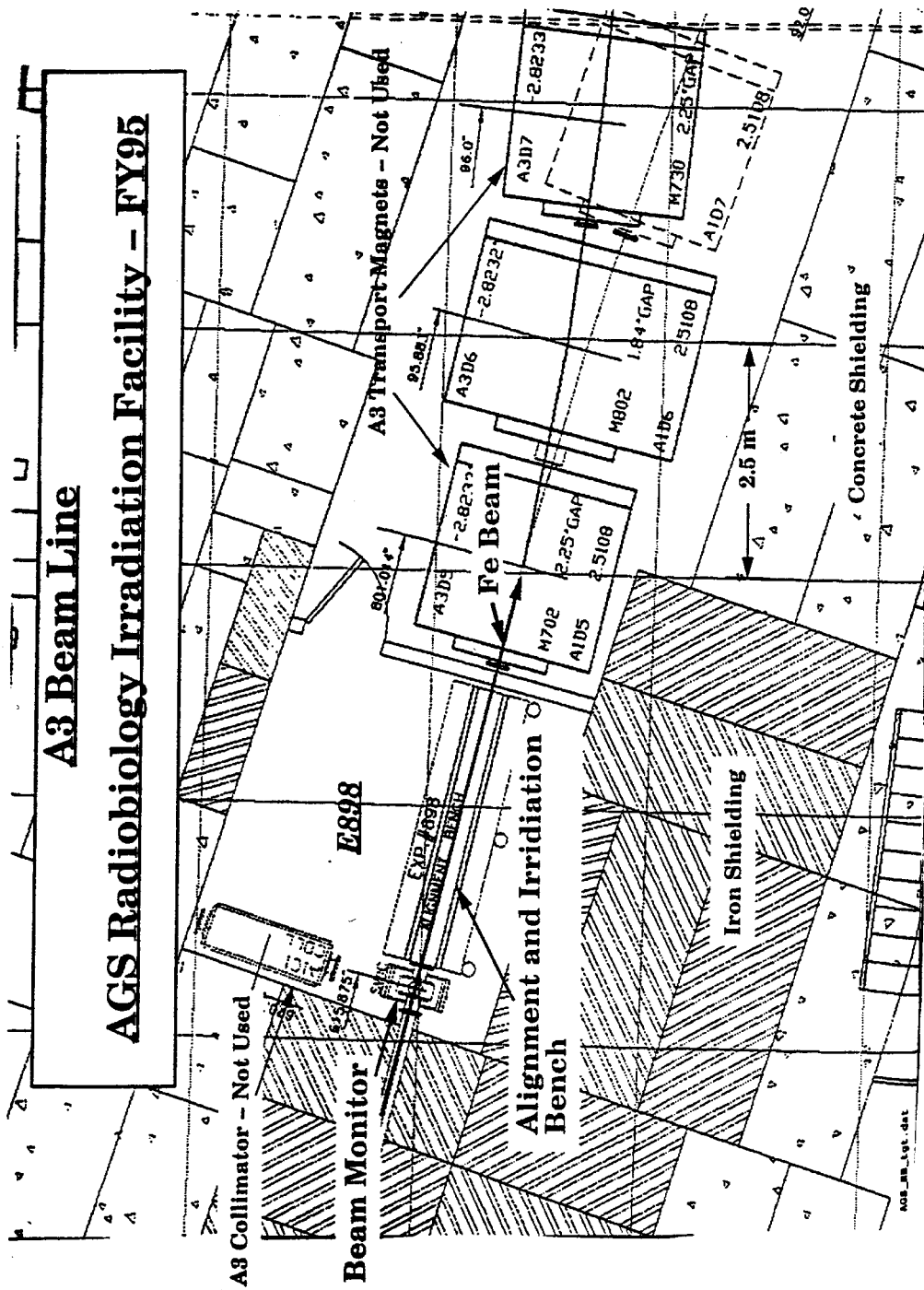

**EXPERIMENT 919- A STUDY OF THE GENETIC AND EPIGENIC EFFECTS  
PRODUCED BY HIGH ENERGY HEAVY IONS  
Spokesmen: M. Vazquez**

- C **Alabama Agr. and Mechanical University** - P. Kale
- C **Brookhaven National Laboratory** - J. Bullis, J. Gatley, B. Sutherland, M. Vazquez
- C **Case Western Reserve University** - H. Evans
- C **Colorado State University** - T. Borak, G. Mariano, C. A. Waldren
- C **Columbia University** - T. K. Hei
- C **Georgetown University medical Center** - T. Jorgensen
- C **Lawrence Berkeley National Laboratory** - P. Cooper, A. Kronenberg, J. Miller
- C **Loma Linda University** - G. Nelson
- C **Los Alamos National Laboratory** - D. J. Chen
- C **NASA Johnson Space Center** - T. C-h Yang
- C **Natl. Inst. of Radiological Sciences, Japan** - Y. Furusawa
- C **Pacific Northwest National Laboratory** - N. F. Metting
- C **USAF Armstrong Laboratory** - A. Cox
- C **Washington State University** - A. Brooks
- C **University of California** - L. H. Lutze-Mann, W. Morgan
- C **University of Maryland Baltimore** - E. Balcer-Kubiczek, B. Rabin
- C **University of Texas** - M. Natarajan

---

This is a NASA effort in the AGS to study the genetic and epigenetic effects produced by high energy heavy ions. There will be two runs labeled BNL-3, 4 (E919) for the period of October 1, 1996 to September 31, 1998. Each run provides 150 hours of 1 GeV/nucleon Fe ions.

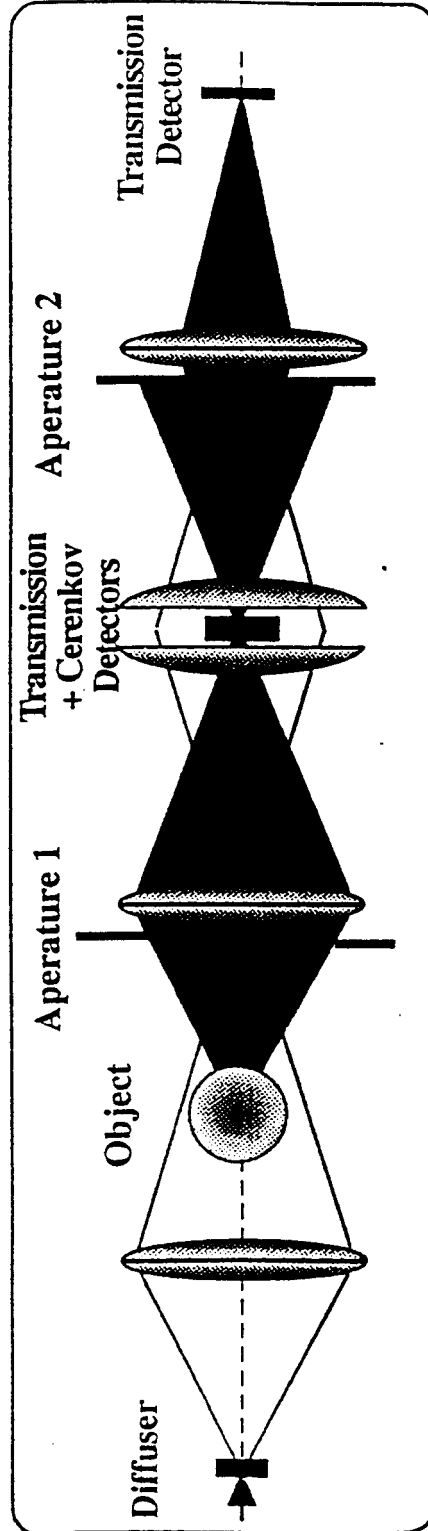

Schematic of a MCS radiographic detector system. The beam is first prepared with a diffuser and matching lens to meet optics requirements. It then passes through the object to be radiographed. The transmitted beam passes through an iris, or aperture, is focused on the first detector, then passes through a smaller diameter iris and is focused on a second detector. The ratio of the first and second detector intensities provides both the density profile and material composition of the object.

Beam : A1  
Status: Complete 1996  
Hours Charged: 197

**EXPERIMENT 920 - LENS TEST FOR PROTON RADIOGRAPHY**  
**Spokesman: J Zumbro**

- **Los Alamos National Laboratory** - G. Hogan, K. Morley, C. Morris, K. Mueller, J Sarracino, H. Z iock, J Z umbro
- 

The goal of this experiment is to provide data for standard test objects which can be benchmarked against models of proton transport and magnetic optics. Additionally the performance of proton radiography will be directly compared with X-ray measurements on the same set of objects.



**EXPERIMENT 922 - RADIATION TESTING OF NASA'S GLOBAL POSITIONING SYSTEM  
AND INERTIAL NAVIGATION SENSOR (GPS/INS)  
Spokesman: W. X. Culpepper**

- **National Aeronautics and Space Administration** - W. X. Culpepper

---

NASA has elected to pursue the development of an integrated global positioning system (GPS) and inertial navigation system (INS) (GPS/INS) for use as common hardware on the International Space Station (ISS), the Space Shuttle Orbiter and the ISS Crew Return Vehicle (CRV). NASA's Johnson Space Center (JSC) is the lead center for this activity. This GPS/INS will perform the prime state vector estimation and navigation functions for the flight vehicles involved and is considered a criticality 1 subsystem, *i.e.*, impacts crew safety, vehicle survivability and mission success.

A facility producing heavy ions with sufficient energy per nucleon is needed to perform system level tests with heavy ions similar to the IUCF proton tests to establish latchup susceptibility for the proposed hardware. The 10-11 GeV gold ion beam scheduled at the AGS in the fall/winter of 1996 is the only American resource known that can accomplish this special testing.



# EXPERIMENT 923

Home Page • <http://www.phy.bnl.gov/~E923/>

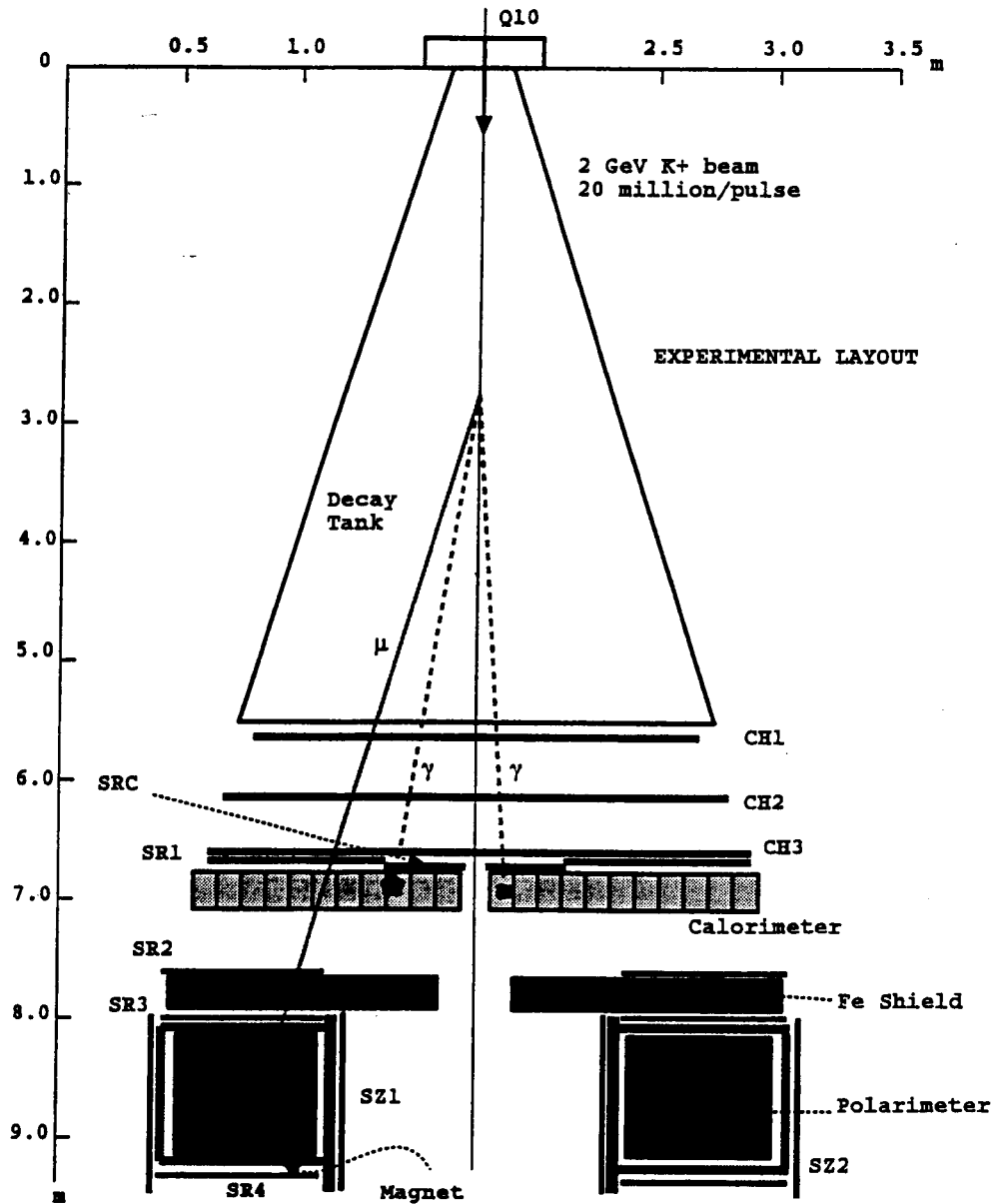

Schematic of the experiment. A typical  $K^+ \rightarrow \mu^+ \pi^0$  event is superimposed.

**EXPERIMENT 923 -SEARCH FOR T VIOLATING MUON POLARIZATION IN  $K^0 \rightarrow \mu^+ B^0_{\mu}$  DECAY**  
**Spokesmen: R. Adair, M. V. Diwan, Hong Ma**

- **Brookhaven National Laboratory** - A. S. Carroll, M. V. Diwan, J. Frank, A. Gordeev, S. Kettell, L. Leipuner, L. Littenberg, H. Ma, V. Polychronakas
- **Institute for Nuclear Research, Moscow, Russia**  
G. Atoyán, V. Issakov, O. Karavichev, S. Laptev, A. Poblaguev, A. Proskuryakov
- **Louisiana Tech University** - M. Elaasar, D. Greenwood, K. Johnston
- **Yale University** - R. Adair, R. Larsen

---

This experiment proposes a new search for the time reversal violating polarization of the muon normal to the decay plane of the  $K^0 \rightarrow \mu^+ B^0_{\mu}$  decay. The experiment will be performed with in-flight decays in an intense ( $2 \times 10^7$   $K^+$  per sec) 2 GeV/c separated kaon beam in an existing beam-line at the AGS. The center piece of the detector will be a new polarimeter which will consist of 128 carbon wedges, with active detector elements (either scintillator or wire chambers) between the wedges, arranged in a cylindrical manner around the kaon beam. More than  $10^9$  events are expected to be analyzed to obtain sensitivity to the T-violating polarization of  $\pm 0.0007$  to  $\langle Im \rangle$ , an improvement by approximately 40 over the previous best limit.

**EXPERIMENT 924**

Home Page • <http://www.npl.uiuc.edu/exp/cb%2b%2b/>

**2GeV Beam Line and Experimental Area for E924**

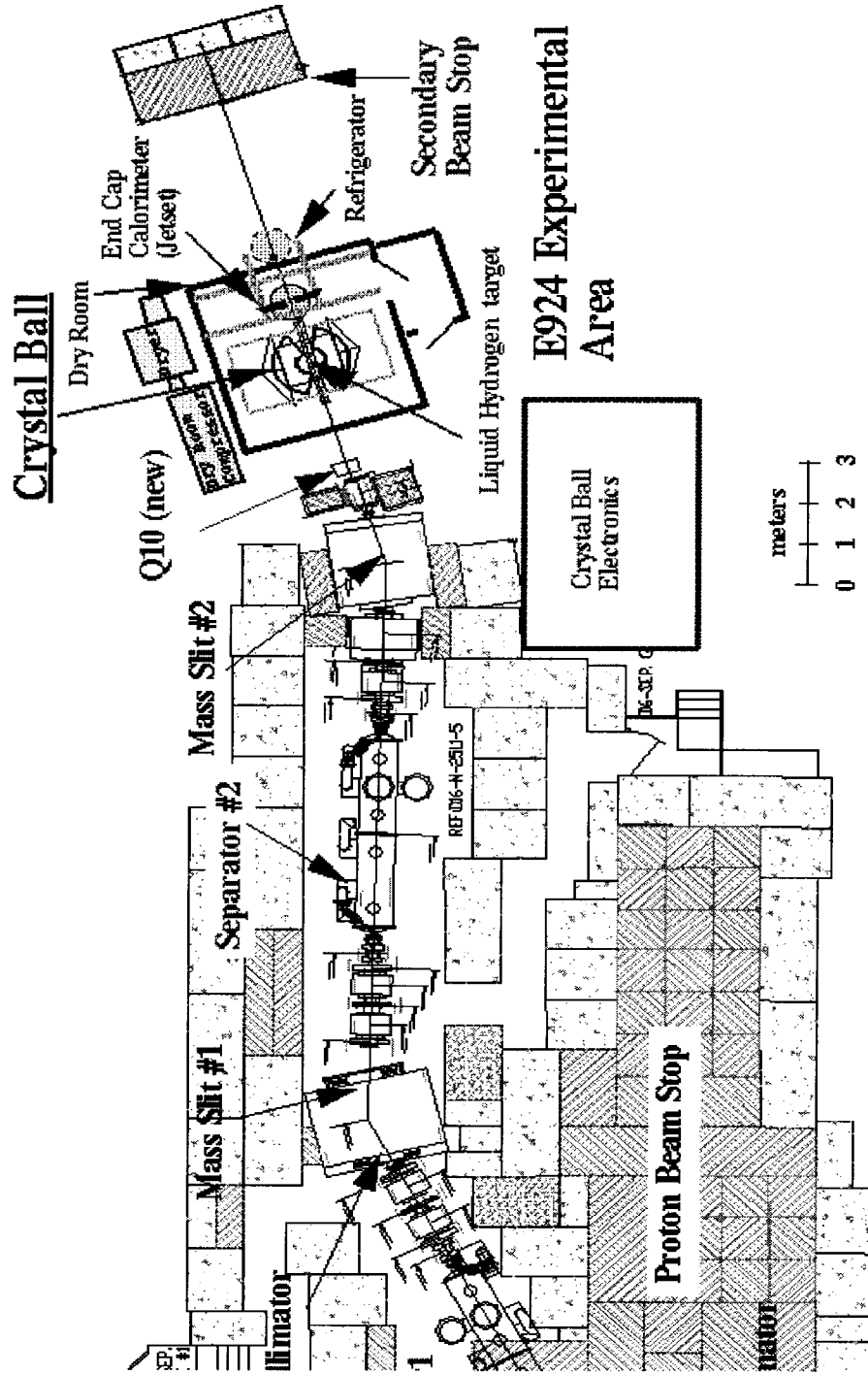

**EXPERIMENT 924 - STUDY OF THE  $\chi(2220)$  IN  $\bar{p}p \rightarrow 6$  NEUTRAL FINAL STATES  
USING THE CRYSTAL BALL IN THE AGS D6 LINE  
SPOKESMAN: D. W. HERTZOG**

- **Boston University** - J. Miller
- **Brookhaven National Laboratory** - T. Kycia, P. Pile
- **Carnegie-Mellon University** - G. Franklin, C. Meyer, B. Quinn, R. A. Schumacher
- **College of William and Mary in Virginia** - M. Eckhause, J. Kane, R. Welsh
- **George Washington University** - C. Bennhold, W. J. Briscoe
- **Kent State University** - D. M. Manley
- **Northwestern University** - K. Seth
- **Petersburg Nuclear Physics Institute** - V. V. Abaev, V. S. Bekrenev, N. G. Kozlenko, S. P. Kruglov, I. V. Lopatin, A. B. Starostin
- **Valparaiso University** - D. Grosnick, D. D. Koetke, R. W. Manweiler, S. Stanislaus
- **University of California at Los Angeles** - M. Clajus, S. C. McDonald, A. Marušf, B. M. K. Nefkens, W. B. Tippens
- **University of Colorado** - R. J. Peterson
- **University of Connecticut** - R. T. Jones
- **University of Illinois at Urbana-Champaign** - P. Debevec, D. W. Hertzog, P. E. Reimer, J. Ritter, S. Sedykh, D. Urner
- **University of Karlsruhe** - H. M. Staudenmaier
- **University of Maryland** - D. Peaslee
- **University of Regina** - G. J. Lolos, Z. Papandreou

---

The experimenters propose to study the reactions  $\bar{p}p \rightarrow 6 B^0\bar{B}^0$ ,  $\bar{p}p \rightarrow 6 B^0\pi^0$ ,  $\bar{p}p \rightarrow 6 \pi^0\pi^0$ , and  $\bar{p}p \rightarrow 6 \pi^0\eta$  in the region of the  $\chi$  using the high-resolution Crystal Ball detector and the D6 (antiproton) beam line.

# EXPERIMENT 925

Home Page • <http://www.ags.bnl.gov/~e925/E925.html>

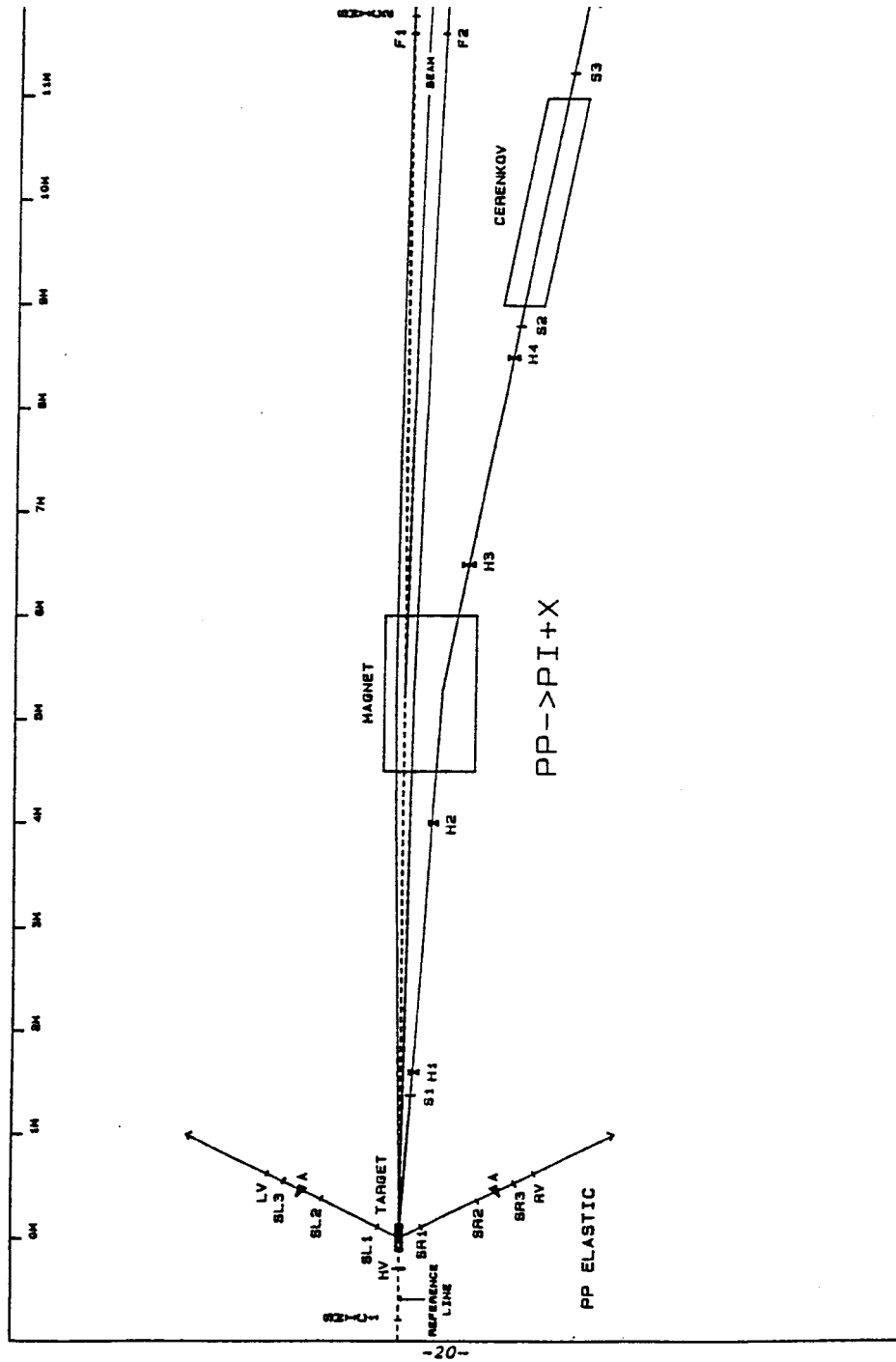

Sketch of the experimental setup for the proposed inclusive pion experiment.

**EXPERIMENT 925 - ASYMMETRIES IN INCLUSIVE PION PRODUCTION AT LARGE  $X_F = (0.5 \text{ TO } 0.8)$   
AND  $P_T \leq 0.8 \text{ GeV}/c$  WITH A POLARIZED BEAM FOR A RHIC POLARIMETER  
SPOKESMEN: Y. MAKDISI AND A. YOKOSAWA**

- **Argonne National Laboratory** - K. Krueger, T. LeCompte, H. Spinka, D. Underwood, A. Yokosawa
- **Brookhaven National Laboratory** - L. Ahrens, J. G. Alessi, K. Brown, G. Bunce, P. Cameron, H. Huang, A. U. Luccio, Y. Makdisi, F. Mariani, L. Ratner, T. Roser, M. Sypers, N. Tsoupras
- **IHEP, Institute for High Energy Physics, Protvino** - N. I. Belikov, A. M. Davidenko, A. A. Derevschikov, S. V. Erin, Yu. M. Goncharenko, Yu. A. Matulenko, L. V. Nogach, S. B. Nurushv, A. I. Pavlinov, A. N. Vasiliev
- **Indiana University** - M. Bai\*, S. Y. Lee
- **Institute for Chemical and Physical Research (RIKEN)** - Y. Goto, H. Hayashi, T. Ichihara, Y. Kondo\*\*, Y. Nakada\*\*, M. Nakamura\*\*, N. Saito
- **Institute for Theoretical and Experimental Physics (ITEP), Moscow** - I. G. Alekseev, V. P. Kanavets, D. N. Svirida
- **University of California-Los Angeles** - K. Barish, L. Betev, V. Ghazikhanian, H. Huang, G. Igo, S. Trentlage, C. Whitten
- **University of Iowa** - N. Akchurin
- **University of Tokyo** - H. Okamura, H. Sakai, T. Wakasa

\* Also Argonne National Laboratory

\*\* Also Kyoto University, Japan

---

The experimenters propose to measure asymmetries in the inclusive reactions,

$$\begin{aligned} & p8p \ 6 \ B^+ \ \text{anything}, \ p8C \ 6 \ B^+ \ \text{anything}, \\ & p8p \ 6 \ B^- \ \text{anything}, \ p8C \ 6 \ B^- \ \text{anything} \end{aligned}$$

using a transversely polarized beam, a liquid hydrogen target, and a carbon target. The measurements would be made using the 23-GeV/c proton beam in an extracted beam line from the AGS, a spectrometer consisting of an analyzing magnet, scintillation hodoscopes, scintillation trigger counters, and a gas threshold Cerenkov counter. The kinematic range covered by the experiments would be  $p_T$  up to 1.0 GeV/c and  $x = p_L/p_{\max} \cdot 0.5 \text{ to } 0.8$ .

The purpose of this proposal is to obtain basic information in order to design a polarimeter for the RHIC polarized beams. The RHIC polarimeter is a crucial item for the success of the RHIC spin program.

# EXPERIMENT 926

Home Page • <http://sitka.triumf.ca/e926/>

---

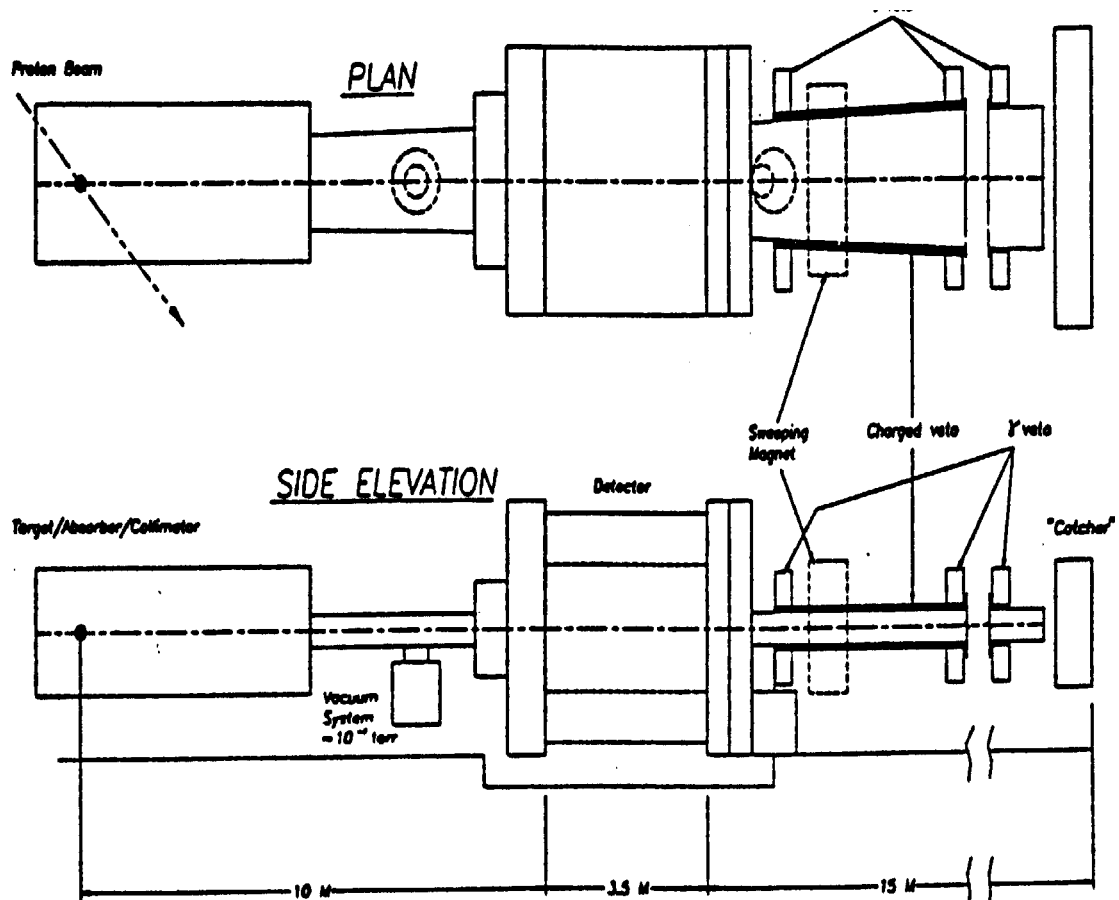

Layout of the  $K_L^0 \rightarrow 6 B^0$  experiment

**EXPERIMENT 926 - MEASUREMENT OF  $K_L^0 \rightarrow 6 B^0 \llcorner \llcorner$**   
**SPOKESMEN: D. BRYMAN, L. LITTENBERG, M. ZELLER**

- **Brookhaven National Laboratory** - I-H. Chiang, J W. Glenn, V. Jain, D. Lazarus, L. Littenberg, R. Strand, C. Woody
- **INR-Moscow** - D. Dementyev, A. Ivashkin, A. Khotjanzev, Y. Kudenko, O. Mineev
- **Kyoto University** - T. Fujiwara, H. Kurashige, N. Sasao
- **Thomas Jefferson National Accelerator Facility** - M. Ito
- **TRIUMF** - E. Blackmore, D. Bryman, P. Gumplinger, P. Kapinos, A. Konaka, J Macdonald, T. Numao, R. Poutissou, G. Smith
- **Virginia Polytechnic Institute** - M. Blecher, K. Kinoshita, M. Pitt
- **Yale University** - S. Dhawan, H. Kaspar, W. Majid, M. Zeller
- **University of British Columbia** - M. Hasinoff
- **University of New Mexico** - B. Bassalleck, J. Lowe

---

This experiment will be a measurement of the rare decay  $K_L^0 \rightarrow 6 B^0 \llcorner \llcorner$ . The method employs kaon time-of-flight and full kinematic reconstruction of the  $B^0$  to suppress backgrounds to a level well below an anticipated signal in the range of  $3 \pm 2 \times 10^{-11}$ .



**EXPERIMENT 929**

Home Page • <http://ejns.phys.sci.osaka-u.ac.jp/Kisimoto-e.html>

---

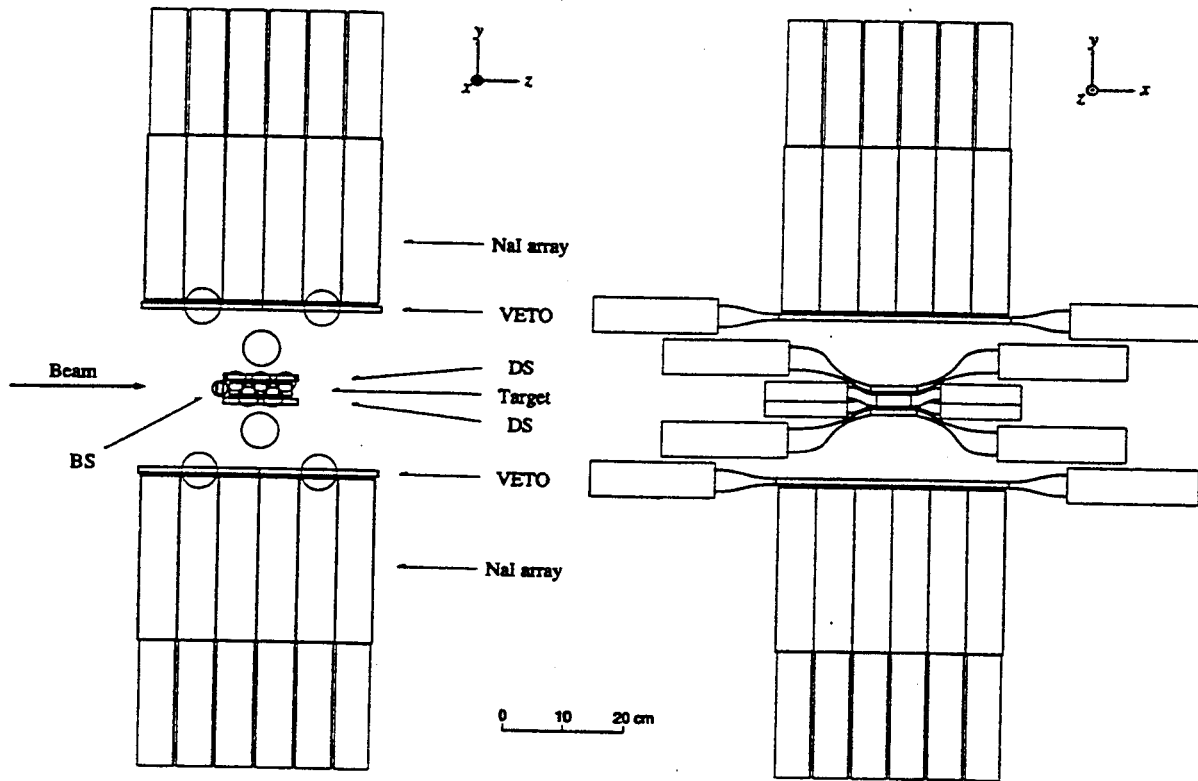

Schematic layout of the target region and the detector are shown.

**EXPERIMENT 929 SPIN-ORBIT SPLITTING OF SINGLE  $\Lambda$  STATE STUDIED BY THE  $^{13}\text{C}(\text{K}^{\&}, \text{B}^{\&})$  REACTION  
SPOKESMAN: T. KISHIMOTO**

- **Brookhaven National Laboratory** - R. E. Chrien, M. May, P. Pile, A. Rusek, R. Sutter
- **Hampton University** - L. Tang
- **Manitoba University** - L. Lee
- **National Laboratory of High Energy Physics** - H. Noumi
- **North Carolina A&T State University** - R. Sawafu
- **Osaka University - Department of Physics** - S. Ajimura, H. Hayakawa, R. Hazama,  
T. Kishimoto, K. Morikubo, E. Sajai, R. Sato
- **Osaka University - Research Center for Nuclear Physics** - N. Kudomi, K. Kume, Y. Mizuno,  
M. Nomachi, K. Tamura
- **Tohoku University** - K. Maeda, T. Suda
- **University of Houston** - M. Ahmed, R. Barber, T. Empl, E. V. Hungerford, K. J. Lan,  
B. W. Mayes, M. Muerlelier, L. S. Pinsky, M. Youn
- **University of Tokyo - Department of Physics** - H. Tamura
- **University of Tokyo - Institute for Nuclear Study** - T. Fukuda, T. Nagae, J. Nakano, H. Oota,  
T. Tamagawa

---

The experimenters propose to measure the spin-orbit( $\lambda$ ) splitting of single  $\Lambda$  particle states in a hypernucleus.

**EXPERIMENT 930**

## Germanium detector system

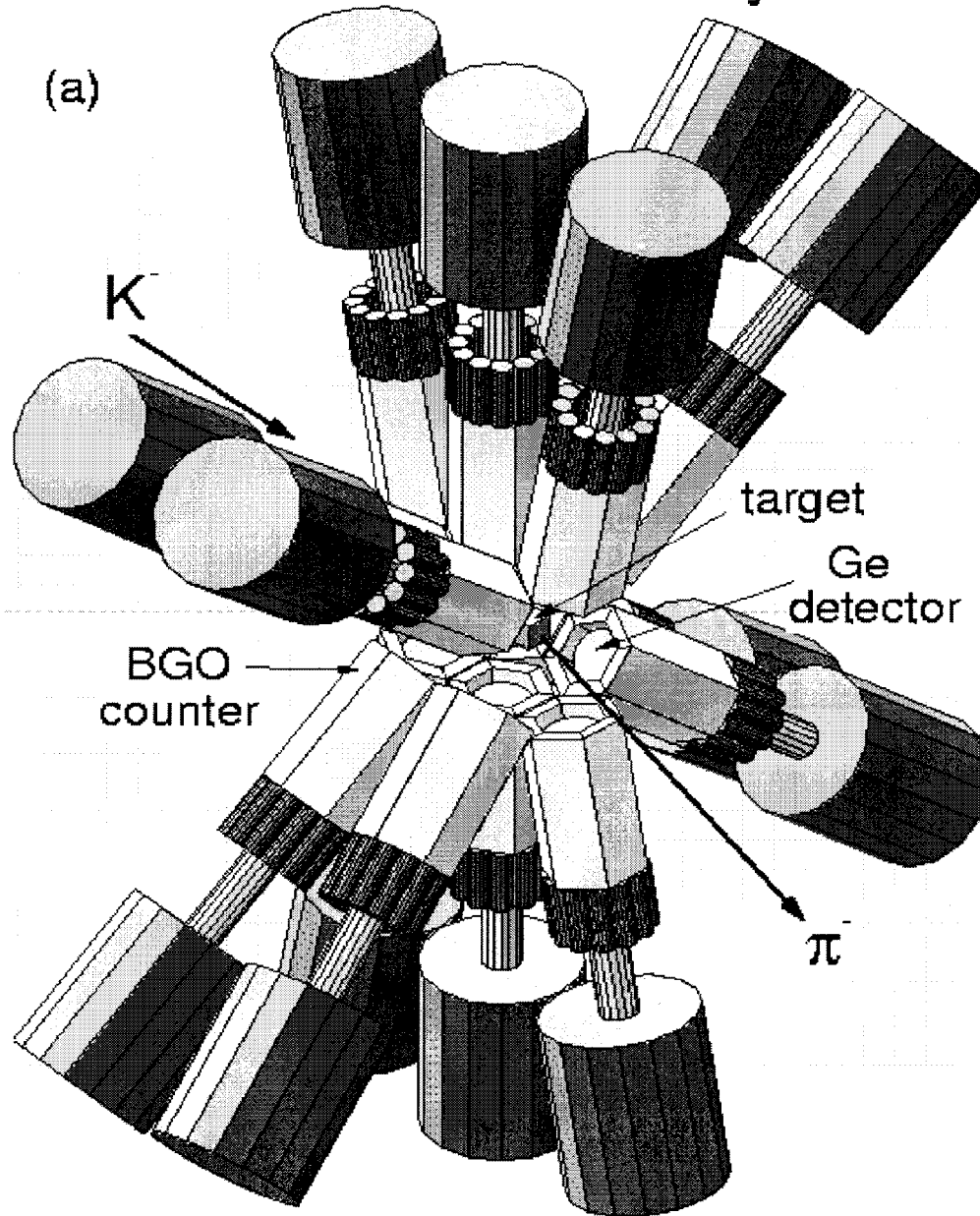

**EXPERIMENT 930 - HIGH-RESOLUTION ( $\gamma$  SPECTROSCOPY OF HYPERNUCLEI  
USING LARGE-ACCEPTANCE GERMANIUM DETECTOR  
SPOKESMAN: H. TAMURA**

- **Brookhaven National Laboratory** - R. E. Chrien, M. May, P. Pile, A. Rusek
  - **Hampton University** - L. Tang
  - **KEK** - T. Fukuda, T. Nagae, H. Noumi, H. Oota
  - **North Carolina A&T University** - R. Sawafu
  - **Osaka University** - S. Ajimura, T. Kishimoto
  - **Tohoku University** - O. Hashimoto, H. Tamura, T. Takehashi
  - **University of Tokyo - Department of Physics** - T. Ishikawa, K. Tanida
- 

The experimenters propose a high-resolution ( $\gamma$ -ray spectroscopy measurement of several light hypernuclei employing a large-acceptance germanium detector system which is being constructed in Japan. Hypernuclei are produced by the ( $K^{\pm}, B^{\pm}$ ) reaction and their  $\gamma$  transitions are detected in coincidence. They will use  $K^{\pm}$  beam at C6 beam line together with the present spectrometer. The aim is to determine  $\gamma$  spin-dependent interactions through  $\gamma$  spectroscopy of some light hypernuclei. Data will be taken with  ${}^9\text{Be}$ ,  ${}^{16}\text{O}$ ,  ${}^{12}\text{C}$  and  ${}^7\text{Li}$  targets and to study  $\gamma$  transitions of  ${}^{15}_7\text{N}$ ,  ${}^9_7\text{Be}$ ,  ${}^{16}_7\text{O}$ ,  ${}^{12}_7\text{C}$ ,  ${}^7_7\text{Li}$ , which will give information on the spin-spin, spin-orbit, and tensor interactions between  $\gamma$  and nucleon.

**EXPERIMENT 931**

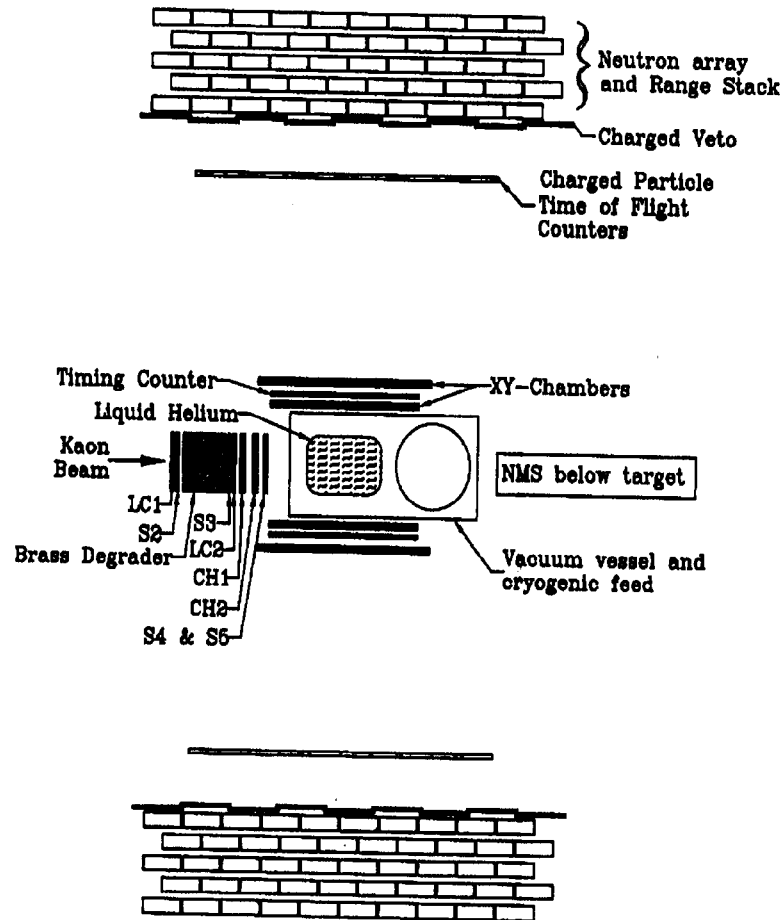

### Top View

Figure 1: Experimental Layout for the weak decay of  ${}^4_{\Lambda}\text{H}$  measurement. The beamline elements are labeled according to their type; S2-5 are scintillator elements, LC designates lucite Cherenkov detectors for  $K/\pi$  separation, and CH designates tracking chambers to determine the direction of the incoming kaon.

**EXPERIMENT 931 - STUDY OF THE  $I = \frac{1}{2}$  RULE IN THE WEAK DECAY  
OF S-SHELL HYPERNUCLEI**

**SPOKESMAN: D. DEHNHARD, E. HUNGERFORD, V. ZEPS**

- **Arizona State University** - J. R. Comfort, C. Gauland
- **Brookhaven National Laboratory** - R. E. Chrien, J. Gerald, M. May, P. H. Pile, A. Rusek, R. Sutter, W. B. Tippens
- **Carnegie-Mellon University** - G. B. Franklin, B. Quinn
- **CEBAF** - L. Tang
- **George Washington University** - W. Briscoe
- **Los Alamos National Laboratory** - J. Amann, D. Boudrie, C. Edwards, B. F. Gibson, C. Morris, J. O'Donnell, J.C. Peng, A. Thiessen
- **Louisiana Tech University** - M. Barakat, K. Johnston
- **North Carolina A&T** - R. Sawafta
- **R. Boskovic Institute** - I. Supek
- **Tohoku University** - O. Hashimoto
- **University of California at Los Angeles** - B. Nefkens
- **University of Colorado** - G. A. Peterson
- **University of Houston** - M. Ahmed, X. Cui, A. Empl, E. V. Hungerford, A. Lan, B. Mayes, L. Pinsky
- **University of Kentucky** - V. Zeps
- **University of Maryland** - P. G. Roos
- **University of Minnesota** - D. Dehnhard
- **University of Texas at Austin** - G. Glass, C. Fred Moore, H. Ward
- **University of Zagreb** - D. Androic, M. Furic, T. Petkovic, M. Planinic

---

This experiment addresses an unresolved, fundamental question of "why" and "when" to apply the  $I = \frac{1}{2}$  rule to the weak decay of strange hadrons. An opportunity now exists to determine if this apparently universal rule applies to the non-mesonic weak decay of a 7, by studying particle emission from an important problem which can only be addressed through the coupling of the NMS spectrometer to the C8 beam line.

**EXPERIMENT 932**  
**Home Page • <http://>**

---

Beam : AGS  
Status: Completed FY 1997  
Hours Charged : 35

**EXPERIMENT 932 - STUDY OF RF BUNCHING TECHNIQUES**  
**SPOKESMAN: J. H. NOREM**

- **Argonne National Laboratory - J. H. Norem**
- **Brookhaven National Laboratory - T. Roser, M. Brennan, L. Lawrence, V. Mane, D. Trbojevic**
- **Fermi National Laboratory - C. Ankenbrandt, C. Johnstone, B. Ng, Z. Qian, M. Popovic**
- **KEK - M. Yoshi**

---

This experiment studied rf bunching techniques that would be relevant to the operating modes for a muon collider driver.



**EXPERIMENT 933**  
**Home Page • <http://>**

---

Beam : U  
Status: Under Consideration  
Hours Charged:

**EXPERIMENT 933 - PROTON RADIOGRAPHY**  
**CONTACT PERSONS: C. MORRIS, E. HARTUNI**

- **Bechtel Nevada** - R. Thompson, R. Liljestrang
- **Lawrence Livermore National Laboratory** - E. Ables, M. B. Aufderheide, R. M. Bionta, P. D. Barnes Jr., T. E. Cowan, D. Fujino, E. P. Hartouni, H-S. Park, R. A. Soltz, K. A. VanBibber, D. M. Wright
- **Los Alamos National Laboratory** - J F. Amann, R. L. Boudrie, G. E. Hogan, N. S. P. King, A. R. Mathews, J B. McClelland, K. B. Morley, C. L. Morris, C.T. Mottershead, K. H. Mueller, J S. Sarracino, G. J. Yates, H. J. Zioc, J D. Zumbro

---

Proton radiography is being investigated as a promising new technology for hydrodynamic testing in support of a science based stockpile stewardship program. It has the potential to outperform traditional X-ray Techniques in meeting the full range of requirements that are being developed by a DOE-DP chartered tri-lab working group. This group was established to identify technical approaches by which an advanced hydrodynamic testing capability could certify the stockpile in the absence of underground testing.

**EXPERIMENT 934**

Home Page • [http://hep.uchicago.edu/~ swordy/access.html](http://hep.uchicago.edu/~swordy/access.html)

---

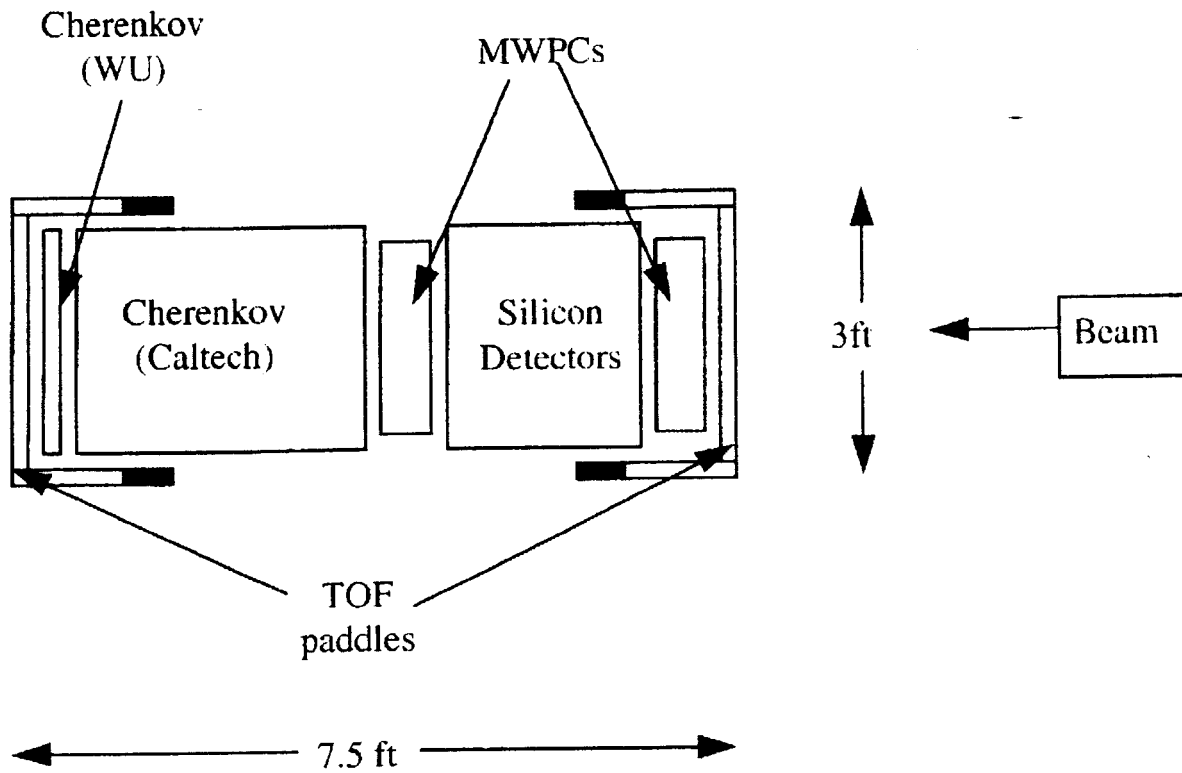

**EXPERIMENT 934 - PROPOSAL FOR BROOKHAVEN CALIBRATION OF DETECTORS  
FOR USE ON ACCESS  
Spokesman: W. R. Binns**

- **Caltech** - T. L. Garrard, R. A. Leske, R. A. Mewaldt, S. M. Schindler, M. E. Wiedenbeck
- **Goddard Space Flight Center** - L. M. Barbier, E. R. Christian, J. W. Mitchell, J. F. Ormes, R. E. Streitmatter
- **Pennsylvania State University** - J. J. Beatty, M. Douvernois
- **Washington University in St. Louis** - W. R. Binns, P. L. Hink, M. H. Israel
- **University of Minnesota** - C. J. Waddington

---

The purpose of this proposed calibration run at Brookhaven is to test and calibrate detectors to determine if they are capable of making precision measurements of the elemental abundances and energy spectra of galactic cosmic rays with  $10 \leq Z \leq 92$ . The Advanced Cosmic Ray Composition Experiment for Space Station (ACCESS) has been approved by NASA for a Mission Concept Study over the next two years. The present concept includes detectors which will be used to precisely measure the charge of these ultra-heavy nuclei.

Experimental goals of the ultra-heavy portion of the mission are: to determine whether the chemical fractionation pattern of GCRs is better organized by FIP or volatility; test whether galactic cosmic rays originate from interstellar dust grains, mass loss from main sequence star, freshly synthesized supernova debris, special sources, such as Wolf-Rayet stars; determine whether  $Z > 30$  and  $Z \leq 30$  nuclei have a common source; test if r-processes that contributed to GCRs were driven further than those that formed the solar system mix by measuring the r/s-process mix as a function of charge.

The detectors are Li-drifted silicon wafer detectors for  $dE/dx$ , waveshifter readout plastic scintillators for  $dE/dx$ , scintillating fibers for time-of-flight, and waveshifter readout Cerenkov counters.

# EXPERIMENT 935

Home Page • <http://wmhcg1.physics.wm.edu/e935>

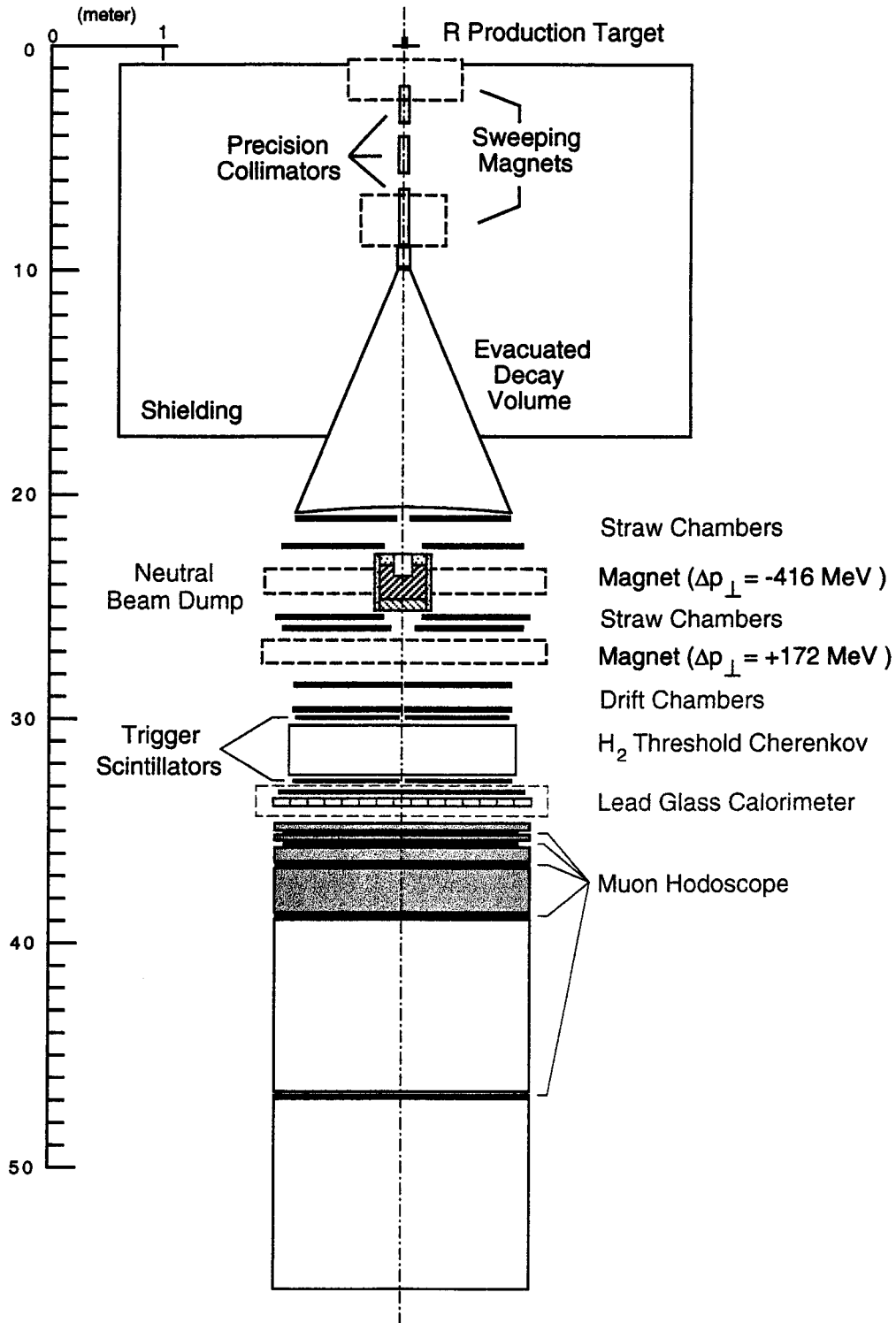

**EXPERIMENT 935 - A DECAY SEARCH FOR A LIGHT GLUINO BOUND STATE IN THE B5 LINE**  
**Spokesman: Y. Kuang**

- **College of William and Mary**  
M. Eckhause, D. Hancock, K. Hern, J. Kane, Y. Kuang, A. Norman, R. Welsh
- **Rensselaer Polytechnic Institute** - M. Witkowski
- **University of California, Irvine** - M. Bachman, G. Kagef, R. Lee, T. Liu, W. Molzon
- **University of Richmond** - P. Rubin

---

The experimenters propose to search at the AGS for the supersymmetry-based  $R^0$  hadron in terms of a decay channel involving a photino and two charged pions with a sensitivity in the product of production cross section and branching fraction of  $5 \times 10^{-36} \text{ cm}^2/\text{GeV}^2$ . A positive signal would be a first observation of a supersymmetric particle.

The detector facility assembled by the E871 collaboration to conduct rare kaon decay studies offers the highest flux neutral beam available and a detector that has acceptable sensitivity to the decay of the  $R^0$ -hadron. The E871 detector in its present configuration would be used to look for two-pion vertex events originating in the decay volume. Achieving an improved vacuum decay tank of  $< 10^{-6}$  torr is the main modification required for the detector system.

Cross-Section View of the E936 Detector Set Up

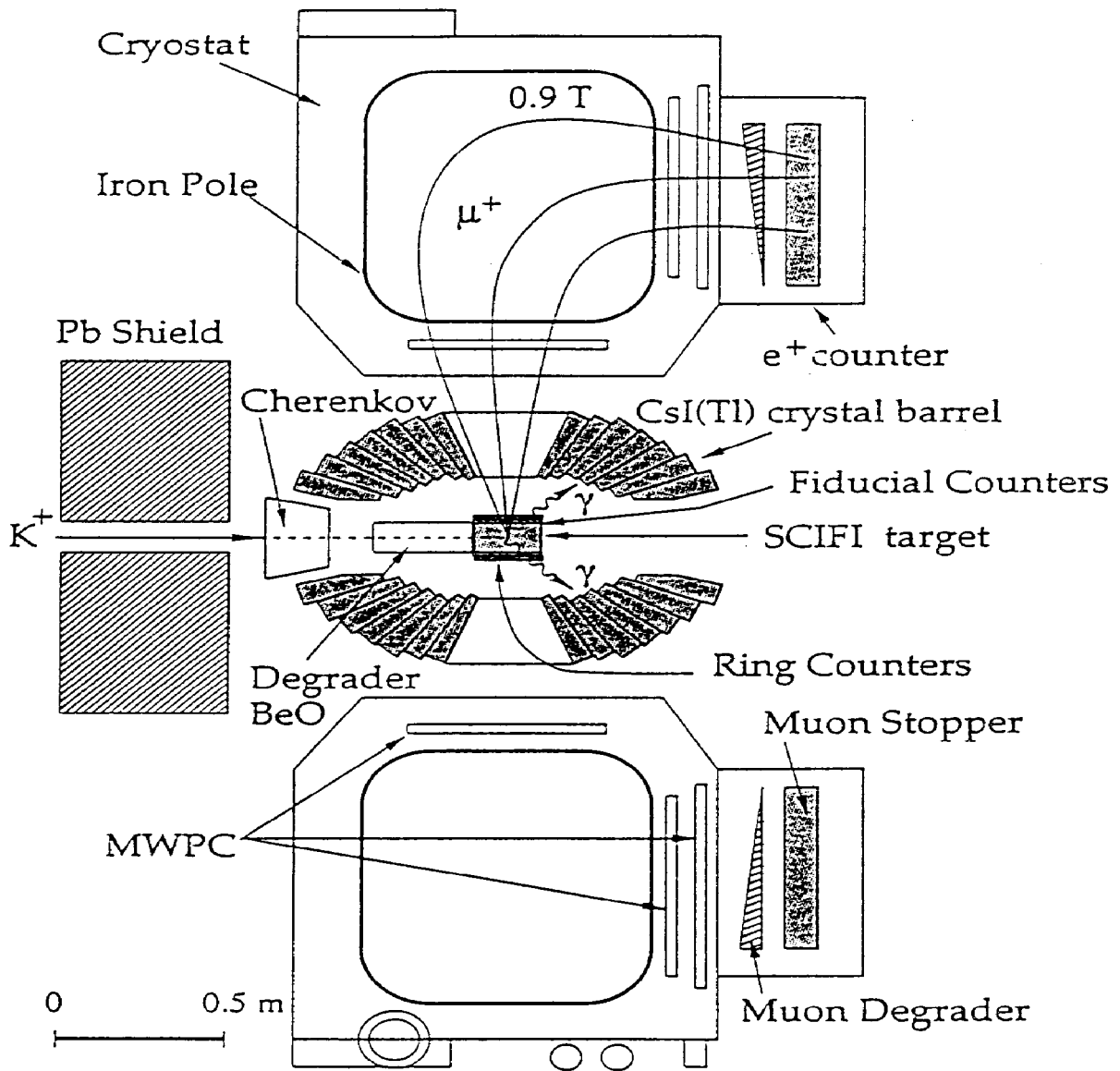

**EXPERIMENT 936 - SEARCH FOR T-VIOLATION IN THE  $K^0 \rightarrow B^0 \mu^+ \mu^-$  DECAY  
USING STOPPED KAONS  
Spokesman: J. Imazato**

- **National Laboratory for High Energy Physics (KEK)** - M. Aoki, M. Chapman, J. Imazato
- **Science University of Tokyo** - K. Nakai
- **Virginia Polytechnic Institute and State University** - M. Blecher
- **University of British Columbia and TRIUMF** - M. Hasinoff, J. A. Macdonald
- **University of Montreal** - P. Depommier
- **University of Saskatchewan** - C. Rangacharyulu, B. Shin
- **University of Tsukuba** - I. Arai, Y. Asano

---

An experiment is proposed to search for T-violation in the  $K^0 \rightarrow B^0 \mu^+ \mu^-$  decay using a stopped beam method. The muon transverse polarization will be examined with high precision and with small systematic errors. The experimental setup will be transferred from the KEK E246 T-violation experiment after the completion of data taking early in 1999. After 3000 hours of running at AGS, the sensitivity of  $|P_T| \cdot 3.5 \times 10^4$  will be obtained corresponding to the sensitivity of  $|Im\epsilon| \cdot 1.5 \times 10^3$ .

**EXPERIMENT 937**  
**Home Page • <http://>**





Beam : D6  
Status: Complete in FY 1997  
Hours Charged/Approved: 16/48

**EXPERIMENT 937 - A STUDY OF THE OCCURRENCE OF RADIATION-INDUCED  
SOFT ERROR UPSETS (SEU)  
Spokesman: R. J. Peterson**

- **University of Colorado** - C. J. Gelderloos, R. J. Peterson
- 

We exposed one sample of a 16 Mbit high density memory chip to negative pion beams of 1.2 and 1.8 GeV/c on the D-line. A plastic scintillator with the same dimensions as the chip was used to monitor the pion fluence. Cross sections for soft errors, changing the bit content of the chip without permanent damage, were found to be much smaller than observed at lower pion momenta. The experiment was truncated by a major equipment problem, and will not be extended because the information obtained is sufficient for the needs to understand avionics failures in commercial aircraft.

**EXPERIMENT 938**  
**Home Page • <http://>**

# BNL-AGS Target Test Experiment

Schematic section along beam center line

Volume of target container 40 liters (544Kg Hg)  
 Total Mercury in system 50 liters (680kg Hg)  
 Capacity of drain tank 60 liters

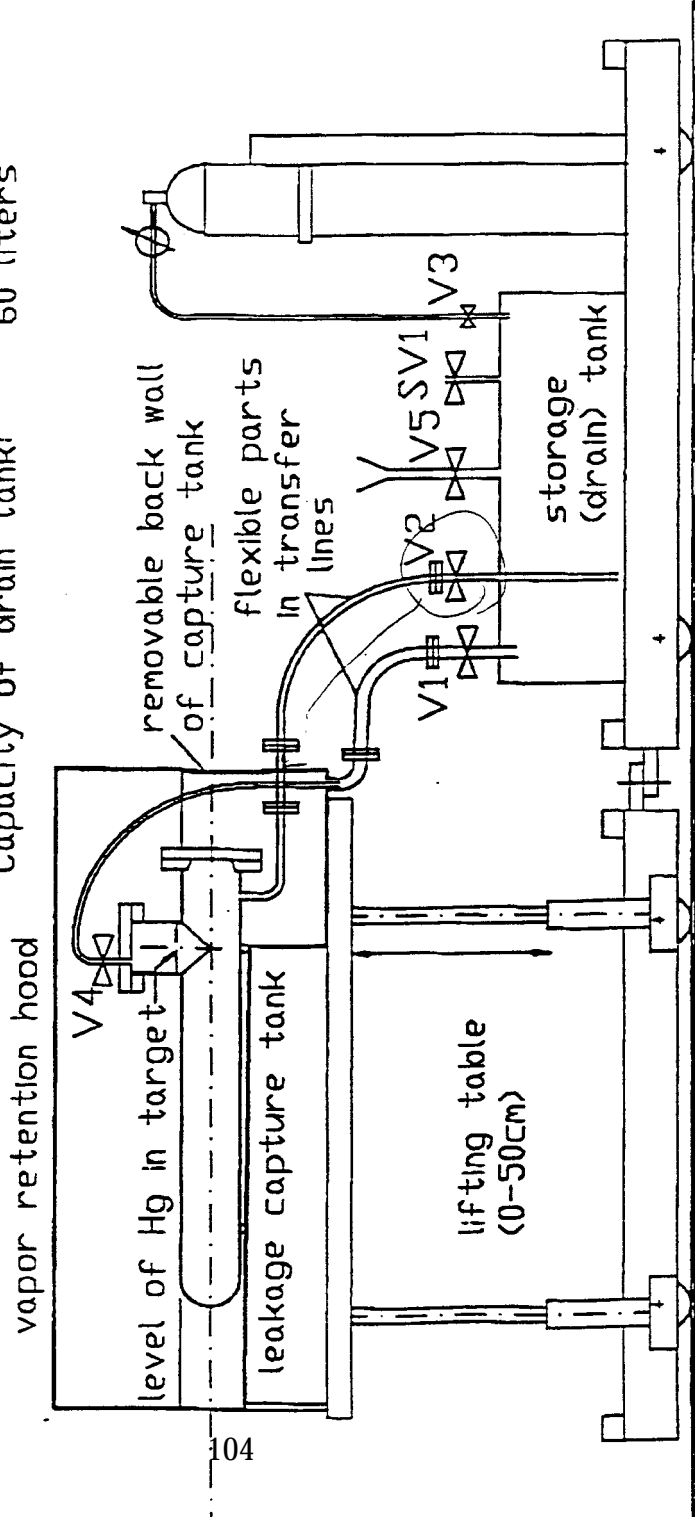

Beam : U  
 Status : In  
 Progress

**EXPERIMENT 938 - SPALLATION NEUTRON TARGET STUDIES AT THE AGS**  
**Spokesmen - G. Bauer, J Haines, J B. Hastings, N. Watanabe**

- **Argonne National Laboratory** - J. M. Carpenter
- **Brookhaven National Laboratory** - J. B. Hastings
- **Forschungszentrum Jilich** - H. Conrad
- **High Energy Accelerator Research Organization (KEK)** - H. Ikeda
- **Japan Atomic Energy Research Institute** - N. Watanabe
- **Los Alamos National Laboratory** - G. Russell
- **Oak Ridge National Laboratory** - J. Haines
- **Paul Scherrer Institute** - G. Bauer

---

There is a worldwide effort in planning and designing the next generation neutron source; the focus is on spallation source with average power of up to 5 MW and single pulse energies of 100 kJoules. The design issues center around the heavy metal target; liquid mercury is the current first choice. The AGS is a unique resource to study in detail neutron production, pressure wave mitigation and other issues in target design. It is the **only** proton source in the world with the energy per pulse equal to the proposed future sources.

The experiment will initially measure the neutron production and energy deposition in liquid mercury as a function of incident proton energy. The pressure wave behavior under peak power loading will then be measured and proposed mitigation measures evaluated. Finally, the performance of a liquid mercury target in conjunction with a lead reflector and moderators will be measured to study the complete system performance. The total proton flux required at a given proton energy is minimal (typically a few times  $10^{14}$ ) for the first two proposed measurement periods.

**EXPERIMENT 939**  
**Home Page • <http://>**

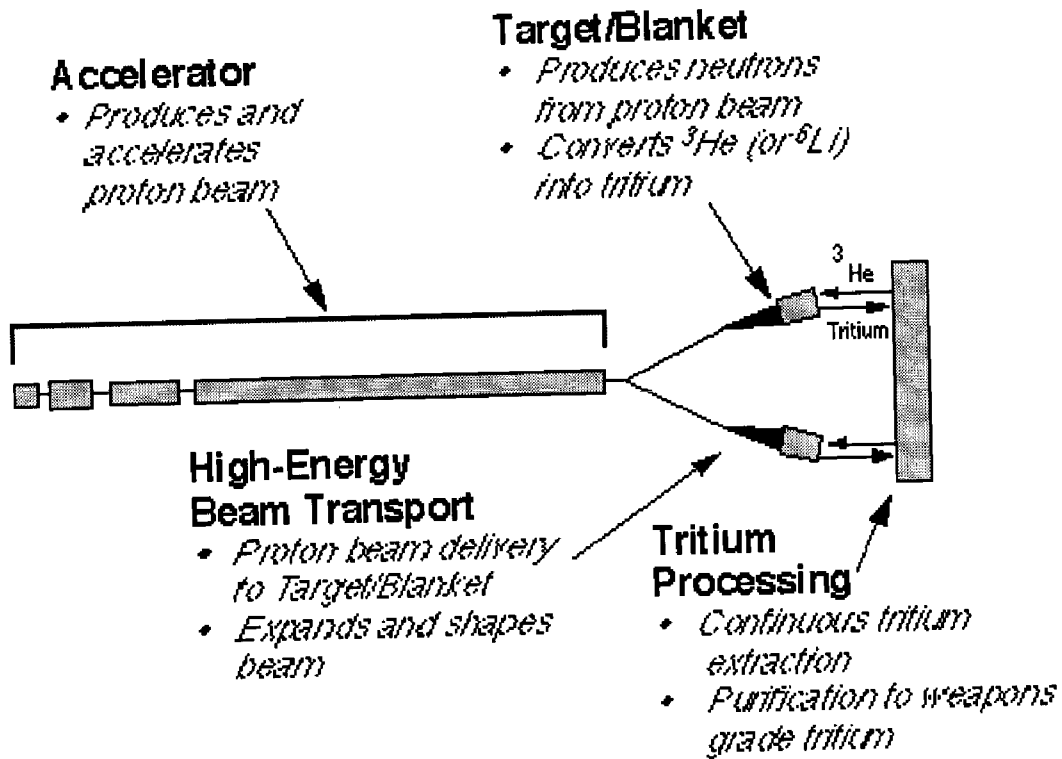

Beam : U  
 Status: In Progress  
 Hours Charged: 51

**EXPERIMENT 939 - EXPERIMENTS FOR THE DOE ACCELERATOR PRODUCTION  
OF TRITIUM (APT) PROJECT  
Spokesmen: N. S.P. King and A. L. Hanson**

- **Bechtel Nevada** - R. Thompson, R. Liljestrand
- **Brookhaven National Laboratory** - G. Greene, A. L. Hanson, L. Snead, M. Todosow
- **CEA** - J. Frehaut
- **Lawrence Livermore National Laboratory** - G. Henry, D. Slaughter
- **LNS-CNRS** - S. Leray
- **Los Alamos National Laboratory**  
K. Alrick, F. Cverna, N. S. P. King, G. L. Morgan, L. Waters, J. Ullmann
- **U. S. Department of Energy** - T. Ward

---

The purpose of this experiment is to advance the R&D work for the accelerator production of tritium in the national program now underway in this subject. Using fast extracted protons, various materials will be exposed to proton beams of 800, 1200, 1600 and 2000 MeV to measure the production cross sections for  $^{27}\text{Al}(p,3n)^{24}\text{Na}$ .

**EXPERIMENT 940**

Home Page • <http://plato.ps.uci.edu/~meco/>

---

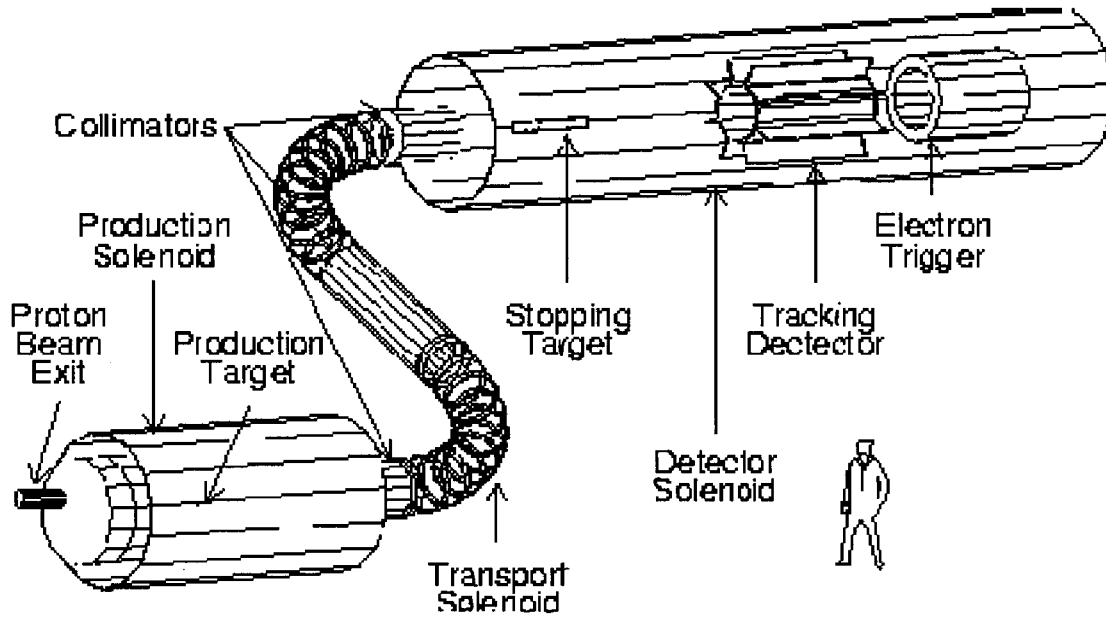

**EXPERIMENT 940 - A SEARCH FOR  $\mu N 6e N$  WITH SENSITIVITY BELOW  $10^{-16}$**   
**MUON-ELECTRON CONVERSION (MECO)**  
**Spokesmen: W. Molzon**

- **Institute for Nuclear Research** - R. M. Djikibaev, V. M. Lobashev, A. N. Toropin
- **New York University** - A. Mincer, P. Nemethy, J. Sculli
- **Purdue University** - S. Carabello, D. Koltick
- **University of California at Irvine** - M. Bachman, G. Kagal, R. Lee, T. J. Liu, W. Molzon, M. Overlin
- **University of Houston** - A. Empl, E. V. Hungerford, K. J. Lan, B. W. Mayes, L. S. Pinsky, J. Wilson, M. Youn
- **University of Pennsylvania** - W. D. Wales

---

This experiment proposes to search for the process  $\mu N 6e N$  with a significantly improved sensitivity with respect to past and proposed future searches. Interest is in searching for violations of additive quantum numbers associated with each type of lepton. Violation of these quantum numbers is commonly referred to as lepton flavor violation (LFV). The process will provide direct evidence of muon and electron number violation.

The experiment will be conducted in a new  $\mu$  beam line produced using a pulsed proton beam. The proton energy will be chosen in the range 8-20 GeV to optimize the  $\mu$  flux per unit time and minimize operating costs of the experiment. The expected sensitivity, normalized to the kinematically similar process of  $\mu$  capture on the nucleus, is one event for a branching fraction of  $2 \times 10^{-17}$ .



**The E864 "Spectrometer" measures**

- Charge ( $Z$ ) and Mass ( $M$ )
- Strangelets from  $M > 7 \text{ GeV}/c^2$  with  $Z/M < 0.3 \text{ e}/\text{GeV}/c^2$

**Elevation View**

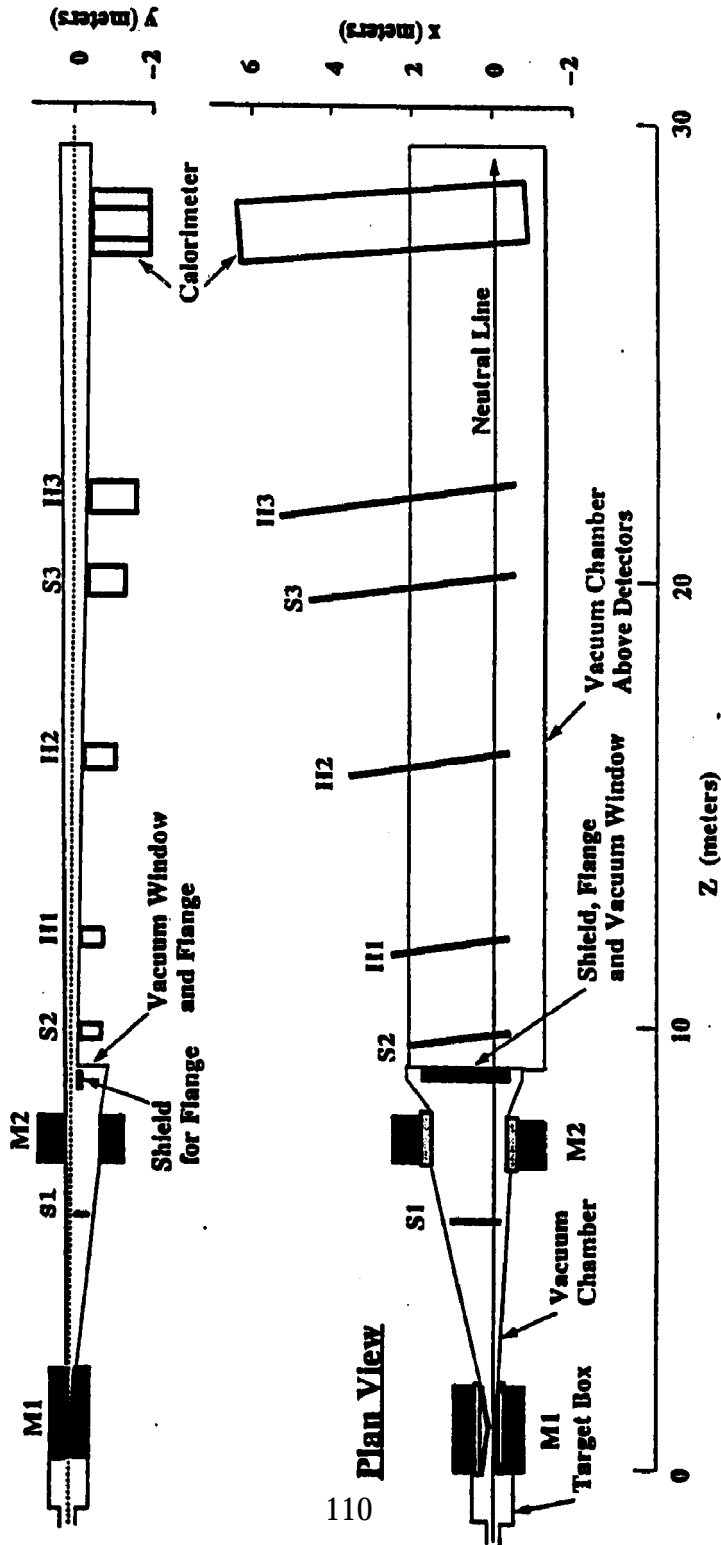

M1 & M2 - dipole spectrometer magnets  
 I11, I12 & I13 - scintillation hodoscopes  
 S1, S2 & S3 - straw tube arrays

**EXPERIMENT 941 - STUDY OF CHARGED AND NEUTRAL LEADING PARTICLES IN p+ A COLLISIONS  
AT THE BNL-AGS  
Spokesmen: H. Huang, R. Majka**

- **Columbia University** - J. Nagle
- **Iowa State University** - B. Fadem, J. Hill, R. Hoversten, J. Lajoie, A. Petridis, H. Skank, G. Sleege, F. Whohn,
- **Massachusetts Institute of Technology** - I. Pless, G. Van Buren
- **Vanderbilt University** - V. Grene, C. Maguire, T. Miller, J. Reid, A. Rose
- **Wayne State University** - S. Bennett, T. Cormier, P. Fachini, H. Jaradat, M. Munhoz, C. Pruneau
- **Yale University** - S. Batsouli, A. Chikanian, E. Finch, N. George, R. Majka, J. Sandweiss, J. Slaughter, Z. Xu
- **University of Massachusetts** - M. Rabin
- **University of California at Los Angeles** - K. Barish, H. Huang, H. Long, E. Yamamoto

---

Although charged leading particles in p+ A collisions have been studied extensively at the beginning of the era for ultra-relativistic heavy ion collisions, neutral leading particles have not been measured accurately and systematically. Neutral leading particles represent a significant fraction of the cross sections for incident proton fragmentation. When the incident proton is described by its quark content and is broken up during nuclear collisions, the emerging leading particles can be combinations of neutron + B<sup>+</sup> or proton + B<sup>0</sup> in the framework of a diquark-quark breakup scenario. This experiment plans to measure both charged and neutral leading particles in p+ Pt, p+ Cu, p+ Al and p+ Be collisions at the beam momenta of 18 and 12 GeV/c with the E864 spectrometer.

The experiment will be conducted in a new  $\mu$  beam line produced using a pulsed proton beam. The proton energy will be chosen in the range 8-20 GeV to optimize the  $\mu$  flux per unit time and minimize operating costs of the experiment. The expected sensitivity, normalized to the kinematically similar process of  $\mu$  capture on the nucleus, is one event for a branching fraction of  $2 \times 10^{-17}$ .

### Publications - AGS Experiments 1982 - 1998

*This listing was originally prepared using the SLAC data base SPIRES; we now rely on the experimenters themselves to supply us with information. It is easy to miss publications in such a wide search and we apologize for any left out or misidentified. Please let us know about these as well as keeping us posted on your recent publications of AGS experiments.*

- 723** D.W. Hertzog, et al., *Precision measurement of the magnetic moment of the  $E^-$*  Phys. Rev. Lett. 51, 1131 (1983).
- 734** L.A. Ahrens, et al., *New limit on the strength of mixing between  $\nu_\mu$  and  $\nu_e$* , Phys. Rev. D31, 2732 (1985).
- L.A. Ahrens, et al., *Measurement of the ratio of cross-sections for neutrino and anti-neutrino-scattering from electrons*, Phys. Rev. Letts. 54, 18 (1985).
- L.A. Ahrens, et al., *Determination of the neutrino fluxes in the Brookhaven wide-band beams*, Phys. Rev. D34, 75 (1986).
- L.A. Ahrens, et al., *Precise determination of  $\sin^2 \theta_w$  from measurements of the differential cross-sections for muon-neutrino  $\nu_\mu$  muon-neutrino  $\bar{\nu}_\mu$  and anti-muon-neutrino  $\bar{\nu}_\mu$  anti-muon-neutrino  $\nu_\mu$* , Phys. Rev. Letts. 56, 1107 (1986).
- L.A. Ahrens, et al., *Measurement of neutrino-proton and anti-neutrino-proton elastic scattering*, Phys. Rev. D35, 785 (1987).
- L.A. Ahrens, et al., *A massive fine-grained detector for the elastic reactions induced by neutrinos in the GeV energy region*, Phys. Rev. D35, 785 (1987).
- 745** M. May, et al. *3d-3p Transition in  $(\mu He^4)^+$* , Proceedings of Workshop on Fundamental Muon Physics: atoms, nuclei and particles, Los Alamos (1986).
- A. Blaer, et al., *Measurement of K x-rays from muonic helium formed in a low density target in an intense pulsed muon beam*, Phys. Rev. A. (1989).
- 747** A. Etkin, et al., *The reaction  $Bp \rightarrow NNn$  and evidence for glueballs*, Phys. Rev. Lett. 49, 1620 (1982).
- S. J. Lindenbaum, *Comments on Glueballs, Multi-Quark States and the OZI Rule*, Phys. Lett. 131B, pp. 221-223 (1983).
- S. J. Lindenbaum, *The Discovery of Glueballs, Surveys in High Energy Physics*. Vol. 4, pp. 69-126, John M. Charap, Editor (Harvest Academic Publishers, London, 1983).
- S. J. Lindenbaum, *Production of Glueballs*, Comments on Nuclear and Particle Physics 13, No. 6, pp. 285-311 (1984).
- S. J. Lindenbaum and H. J. Lipkin, *Comments on the Reaction  $Bp \rightarrow NNn$  and Glueballs*, Phys. Lett. 149B, p. 407 (1984).
- A. Etkin, et al., *Observation of three  $2^{++}$  resonances in the glueball-enhanced channel  $BB \rightarrow NNn$* , Phys. Lett. B165, 217 (1985).

## Publications

---

- S.J. Lindenbaum and R.S. Longacre, *The glueball resonance and alternative explanations of the reaction  $Bp \rightarrow NNn$* , Phys. Lett. 165B, 202 (1985).
- 748** P.H. Hansen, et al., *Spin effects in  $pp$  elastic scattering at 28 GeV/c*, Phys. Rev. Lett. 50, 802 (1983).
- 749** J.K. Black, et al., *Measurements of the CP-non-conservation parameters  $\eta, \eta'$* , Phys. Rev. Lett. 54, 1628 (1985).
- 754** P. Kammel, et al., *First observation of hyperfine transitions in muonic deuterium atoms via resonant  $D\mu D$  formation at 34-K*, Phys. Lett. 112B, 319 (1982).
- W.H. Bertl, et al., *Hyperfine transition of  $\mu d$  atoms in liquid hydrogen-deuterium mixture*, Kerntechnik 43, 184 (1983).
- 755** G.C. Blazey, et al., *Hard scattering with exclusive reactions:  $Bp$  and meson production*, Phys. Rev. Lett. 55, 1820 (1985).
- S. Heppelmann, et al., *Decay distribution of high-transverse-momentum  $D$  mesons*, Phys. Rev. Lett. 55, 1824 (1985).
- 766** M. Church, et al., *Exclusive Cascade Minus Production in 15-28 GeV Neutron-Proton Interactions*, invited paper presented at the 23rd International Conference on High Energy Physics, Berkeley, CA, July 1986.
- G. Tzanakos, *Search for neutrino oscillations*, Proceedings of BNL Neutrino Workshop, M. Murtagh, editor (1987).
- E. P. Hartouni, et al., *Some Preliminary Results from BNL E766 on  $pp \rightarrow pp K_s^0 K_B$* . Contribution to the BNL Workshop on Glueballs, Hybrids and Exotic Hadrons, August 29-September 1, 1988.
- E.P. Hartouni, et al., *A New Technique for On-Line and Off-line High Speed Computation*, IEEE Transactions on Nuclear Science, 36, No. 5, October 1989.
- E.P. Hartouni, et al., *A New Technique for On-Line and Off-Line High Speed Computation*, IEEE Transactions on Nuclear Science 36, 1480 (1989).
- L. Wiencke, et al., *Photon Production in Fully Reconstructed  $PP$  Collisions at 27.5 GeV/c*. Presented at the Pittsburgh Workshop on Soft Lepton Pair and Photon Production, September 6-8, 1990.
- L.R. Wiencke, et al., *Observation of the Coulomb Effects in Production of  $B^+ B^-$ ,  $pB^-$ , and  $K^+ K^-$  Pairs in  $pp$  Collisions at 27.5 GeV/c*. Submitted to Phys. Rev. Lett., March 6, 1992.
- J. Felix, et al., *Study of  $7^0$  Polarization in  $pp \rightarrow p7^0 K^+ B^+ B^- B^-$  at 27.5 GeV*, Phys. Rev. Letts. 76, 22 (1996).
- 767** T. Armstrong, et al., *A search for narrow states in anti-neutron proton total and annihilation cross-sections near anti- $NN$  threshold*, Phys. Lett. B175, 383 (1986).
- 769** R.S. Longacre, et al., *A measurement of  $B-p \rightarrow KO-S KO-Sn$  at 22 GeV/c and a systematic study of the  $2^+ +$  meson spectrum*, Phys. Lett. 177B, 223 (1986).

Publications

- 
- 771** S.U. Chung, et al., *Spin and parity analysis of  $K\bar{K}B$  system in the  $D$  and  $E/4$  regions*, Phys. Rev. Lett. **55**, 779 (1985).
- D.R. Reeves, et al., *Spin-parity analysis of  $p\bar{p} \rightarrow E(1420)X$* , Phys. Rev. **D34**, 1960 (1986).
- A. Birman, et al., *Partial-wave analysis of the  $K^+ \bar{K}^0 B^-$  system*, Phys. Rev. Lett. **61**, 1557 (1988).
- 773** H. Piekarczyk, *Searches for dibaryons of strangeness -1*. NP A463 (1987) 205c, Nucl. Phys. **A450**, 85c, (1986).
- Shlomit Tarem, Physics Department, Brandeis University, 1987. PHD Thesis.
- Y. D. He, P. B. Price, and W. T. Williams, *Interactions of projectile fragments at 14.5 A GeV: A search for anomalous*, Phys. Lett. **B 252**, 331-335 (1990).
- 774** R.E. Chrien, E.V. Hungerford, and T. Kishimoto, *Continuum Effects and the Interpretation of  $E$ -Hypernuclei*. Phys. Rev. **C35**, 1589 (1987).
- 777** N.J. Baker, et al., *Search for Short-Lived Neutral Particles Emitted in  $K^+$  Decay*, Phys. Rev. Lett. **59**, 2832 (1987).
- C. Campagnari, et al., *Search for the Decay  $K^+ \rightarrow B^+ \mu^+ e^-$*  Phys. Rev. Lett. **61**, 2062 (1988).
- D.M. Lazarus, et al., AIP Conference Proceedings 176, 3rd International Conference on the Intersections Between Particle and Nuclear Physics, G. Bunce, editor (1988).
- A.M. Lee, et al., *Improved Limit on the Branching Ratio of  $K^+ \rightarrow B^+ \mu^+ e^-$*  Phys. Rev. Lett. **64**, 165 (1990).
- C. Alliegro, et al., *Rare  $K^+$  Decays in Flight: Latest Results and Future Plans*, Particles and Fields 1991, The Vancouver Meeting, 587 (1991).
- 778** B.C. Stringfellow, et al., *Accelerator internal target experiments using a supersonic gas jet*, NIM **A251**, 242 (1986).
- 779** Y.Y. Chu and M.C. Zhou, *Identification of  $^{233}\text{Ac}$* , Phys. Rev. **C28**, 1379 (1983).
- 780** H.B. Greenlee, et al., *A Search for  $K_L^0 \rightarrow \mu^+ e^-$  and  $K_L^0 \rightarrow e^+ e^-$* . BNL 40452.
- E. Jastrzembski, et al., Phys. Rev. Lett. **D61**, 2300 (1988).
- S.F. Schaffner, et al., Phys. Rev. **D39**, 990 (1989).
- 782** K.A. Brown, et al., *Measurement of  $p^+ p \rightarrow p^+ p$  with a 16.5 GeV/c polarized proton beam*, Phys. Rev. **D31**, 3017 (1985).
- G. R. Court, et al., *Energy dependence of spin effects in  $p\bar{p} \rightarrow p^+ p^-$* , Phys. Rev. Lett. **57**, 507 (1986).
- D.G. Crabb, et al., *Measurement of Spin Effects in  $p^+ p \rightarrow p^+ p^-$  at 18.5 GeV/c*, Phys. Rev. Lett. **60**, 2351 (1988).

## Publications

- 
- 785 Y.I. Makdisi, *Experimental results on spin physics at the AGS*, 7th Int. Symp. on High Energy Spin Physics, Protvino, USSR, September 22, 1986.
- 787 S. Ahmad, E.W. Blackmore, D.A. Bryman, J. Cresswell, T. Numao, *Central drift chamber for rare kaon decay spectrometer*, IEEE Trans. Nucl. Sci. NS-33, 178 (1986).
- R. C. Strand, *Status of a Study of the Decay  $K^+ \rightarrow B^+ \bar{\nu}$* , Third Conf. on the Intersections Between Particle and Nuclear Physics, Rockport, Maine, Ed. Gerry M. Bunce, pp. 866-73 (1988).
- M.S. Atiya, et al., *A Study of  $K^+ \rightarrow B^+ \bar{\nu}$* , IX European Symposium on Anti-proton-Proton Interactions and Fundamental Symmetries, Mainz, W. Germany, Sept. 5-10, 1988.
- J.V. Cresswell, S. Ahmad, B.W. Blackmore, D.A. Bryman, N. Khan, Y. Kuno, T. Numao, *A cylindrical drift chamber for the measurement of  $K^+ \rightarrow B^+ \bar{\nu}$  decay*, IEEE Trans. Nucl. Sci, 35, 460-463 (1988).
- C. L. Woody, *Aging effects in wire chambers operated at low pressure with TMAE and its effect on the use of  $BaF_2$  TMAE calorimetry at the SSC*, Proc., Workshop on Radiation Effects at the SSC, Berkeley, CA., Ed. M.G.D. Gilchriese, pp. 207-14 (1988).
- J. S. Frank and R. C. Strand, *Construction and performance of a plastic scintillating fiber target for a rare kaon decay experiment*, Proc. Workshop on Scintillating Fiber Detector Development for the SSC, Batavia, IL., Nov. 14-16, 1988, 1 pp. 361082.
- M. Atiya, M. Ito, J. Haggerty, C. Ng and F. W. Sippach, *Waveform digitizing at 500 MHz*, Intern. Conf. On Advanced Technology and Particle Physics, Como, Italy, June 13-17, 1988, Nucl. Instrum. And meth., A279, 180-5 (1989).
- M.S. Atiya, et al., *Search for  $K^+ \rightarrow B^+ \bar{\nu}$* , Proc., "Rare Decay Symposium," Vancouver, B.C., Nov. 1988, D. Bryman, J. Ng, T. Numao, and J.M. Poutissou, Editors, World Scientific, Singapore, pp. 61-80, 1989.
- M.S. Atiya, et al., *Search for the Rare Decay  $K^+ \rightarrow B^+ \bar{\nu}$* , Proceedings, "Fourth Family of Quarks and Leptons: Second Intern. Symposium," Santa Monica, CA, Feb. 1989, Annals of the Academy of Sciences 578, 202-14 (1989).
- M.S. Atiya, et al., *A Search for a Light Higgs Boson in the Decay  $K^+ \rightarrow B^+ H$ ,  $H \rightarrow \mu^+ \mu^-$* , Phys. Rev. Lett. 63, 2177-80 (1989).
- P.D. Meyers, *Brookhaven Experiment 787, The Search for  $K^+ \rightarrow B^+ \bar{\nu}$*  Proc., "24th Rencontres de Morind Session on Electroweak Interactions and Unified Theories, Les Arcs, France, March 5-12, 1989.
- M.A. Selen, *Hunting for the rare decay  $K^+ \rightarrow B^+ \mu^+ \mu^-$* , Princeton University DOE/ER-3072-49, January 1989.
- M. Atiya, et al., *Waveform Digitizing at 500 MHz*, IEEE Trans. on Nucl. Sci. 36, 813-7 (1989).
- Daniel S. Akerib, *A Search for the Rare Decay  $K^+ \rightarrow B^+ \bar{\nu}$* , Princeton University OE/ER-3072-64. January 1989.
- C. L. Woody, P. W. Levy and J. A. Kierstead, *Slow component suppression and radiation damage in doped  $BaF_2$  Crystals*, IEEE Trans. on Nucl. Sci. 36, 536-42 (1989).

- 
- M.S. Atiya, et al., *Search for the Decay  $K^0 \rightarrow B^0 \pi^0$* , Phys. Rev. Lett. 64, 21-4 (1990).
- M.S. Atiya, et al., *Search for the Decay  $K^+ \rightarrow B^+ \pi^0$* , Phys. Rev. Lett. 65, 1188-91 (1990).
- M.S. Atiya, et al., *Search for the Flavor-Changing Neutral Current Decay  $K^+ \rightarrow B^+ \pi^0$* , Proc. 15th APS Division of Particles and Fields General Meeting, Houston, Texas, Jan. 3-6, 1990.
- M.S. Atiya, et al., *Search for the decay  $K^+ \rightarrow B^+ \pi^0$* , Phys. Rev. Lett. 64, 21-4 (1990).
- D. Bryman, et al., *500-MHZ transient digitizers based on GaAs CCDs*, Proc., Symposium on Detector Research and Development for the Superconducting Supercollider, eds. T. Dombek, V. Kelly, and G. P. Yost, World Scientific pp 505-507 (1991).
- T. Numao, et al., *Recent results on rare  $K^+$  decays from BNLE787*, Proc., Fourth Intl. Conf. on interactions between particles and nuclei, Nucl. Phys. A527, 727 (1991).
- M. S. Atiya, et al., *Upper limit on the branching ratio for the decay  $B^0 \rightarrow \pi^0 \pi^0$* , Phys. Rev. Lett. 66, 2189-92 (1991).
- M. Atiya, et al., *Search for  $K^0 \rightarrow B^0 \pi^0$  and other rare  $K^+$  decays*, Nucl. Phys. A527, 727 (1991).
- I. H. Chiang and L. Littenberg, *CsIR&D*, Proc. KEK Workshop on Rare Kaon Decay Physics, Ibaraki-Ken, Japan, Dec. 1991, T. Shinkawa and S. Sugimoto eds. Pp. 303-309, 1992.
- M.S. Atiya, et al., *A detector to search for  $K^0 \rightarrow B^0 \pi^0$* . Nucl. Instr. & Methods, A321, 129-151 (1992).
- M.S. Atiya, et al., *Search for the decay  $B^0 \rightarrow \pi^+ \pi^-$* . Phys. Rev. Lett. 69, 733-736, (1992).
- M. Ito, et al., *Search for  $K^0 \rightarrow B^0 \pi^0$* . Proc., Moriond Conf., Les Arcs, France (1993).
- M. Atiya, et al., *Search for the decays  $K^0 \rightarrow B^0 \pi^0$* . Phys. Rev. Lett. 70, 2521-4 (1993).
- C. Zein, et al., *A High Speed Fastbus Interface to VME*. Real-Time Computing Appl. 1993, 103 (1993).
- M.S. Atiya, et al., *Search for the decays  $K^+ \rightarrow B^+ \pi^0$  and  $K^+ \rightarrow B^+ X^0$  for  $150 < M_X < 250 \text{ MeV}/c^2$* , Phys. Rev. D48, R1 (1993).
- M.S. Atiya, et al., *An improved search for the decay  $K^+ \rightarrow B^+ \pi^0$* , Phys. Rev. Lett. 70, 2521 (1993).
- M. Burke, et al., *E787 Data acquisition software architecture*, Conf. Record of the 8th Conf. on Real-Time Computer Applications in Nuclear, Particle, and Plasma Physics, Vancouver, June 8-10, 1993, eds. D. Axen and R. Poutissou, p. 361-4 (1993).
- J.S. Frank, *Status and future plans for BNL Experiment E787 ( $K^+ \rightarrow B^+ \pi^0$ )*. Proc. of the Workshop on Future Directions in Particle and Nuclear Physics at Multi-GeV Hadron Beam Facilities, D. F. Geesaman, Editor, pp. 428-33, 1993.
- M. Burke, et al., *E787 Data Acquisition Software Architecture*, IEEE Trans. Nucl. Sci., NS-41, 131-4 (1994).

## Publications

- 
- M. M. Ito, *Results from BNL E787, a Search for  $K^0 \rightarrow B^0 \mu^+ \mu^-$* . Proc. 1994 Workshop on Heavy Quarks Physics at Fixed Target, University of Virginia, Charlottesville, VA., October 1994, B. Cox, Editor, pp. 359-364, 1994.
- C. Witzig, *Recent results on rare kaon decays from BNL E787*, Proc. XXIX Rencontre de Moriond, Mar. 1995, J. Trân Thanh Vân, Ed., 361-5, (1994).
- M. Kobayashi, et al., *YALO<sub>3</sub>: Ce-Am light pulsers as a gain monitor for undoped CsI detectors in a magnetic field*, Nucl. Instr. & Method., A337, 3550-361 (1994).
- J. Haggerty (for the E787 collaboration), *Observation of  $K^+ \rightarrow B^+ \mu^+ \mu^-$* , Proc. of XXVII Intl. Conf. on High Energy Physics, P. J. Bussey and I. G. Knowles, eds., 1341, (1995).
- J. Roy, et al., *Status of E787*, Proc. Intersection between Particle and Nuclear Physics: Fifth Conf. Held in St. Petersburg, Fla., June 1994 ed. S. J. Seestrom, Los Alamos Natl. Laboratory (1995).
- I-H. Chiang, et al., *A new CsI (undoped) Endcap Photon veto system for BNL E787: A study of the decay  $K^0 \rightarrow B^0 \mu^+ \mu^-$* . Proc. of Vth Intl. Conf. on Calorimetry in High Energy Physics, H. Gordon and D. Ruger eds, 103 (1995).
- A. Konaka, *Status of BNL E787*, Proc. 23rd INS International Symposium, Tokyo, Japan, March 1995, S. Sugimoto and O. Hashimoto, Editors, pp. 119-127, 1995.
- R. A. McPherson, *Chasing the rare decay  $K^0 \rightarrow B^0 \mu^+ \mu^-$* , Princeton University PRINCETON/HEP/95-9 Nov. 1995.
- I. Chiang, et al., *CsI Endcap Photon Detector for  $K^0 \rightarrow B^0 \mu^+ \mu^-$  Experiment at BNL*, IEEE Trans. Nucl. Sci. vol NS-42, no. 4, pp 394-400, August 1995.
- S. Adler, et al., *Search for the Decay  $K^0 \rightarrow B^0 \mu^+ \mu^-$* , Phys. Rev. Lett. 76, 1421, (1996).
- E. W. Blackmore, D. A. Bryman, H.Y. Juno, C. Lim, T. Numao, P. Padley, G. Redlinger, R. Soluk, *Central tracking chamber with inflated cathode-strip foils*, Nucl. Instr. Meth. A (1996).
- M. Convery (for the E787 collaboration), *First measurement of the structure dependent decay  $K^+ \rightarrow B^+ \mu^+ \mu^-$* , Proc. 1996 Annual Mtg. of American Physical Society, Div. of Particles and Fields (DPF'96), Minneapolis, MN., Aug. 10-15, 1996.
- S. Adler (for the E787 collaboration), *First observation of  $K^+ \rightarrow B^+ \mu^+ \mu^-$* , Proc. of 1996 Annual Mtg. of American Physical Society, Div. of Particles and Fields (DPF'96), Minneapolis, MN., Aug. 10-15, 1996.
- T. Shinkawa, *BNL E787 search for  $K^0 \rightarrow B^0 \mu^+ \mu^-$* , Proc. Workshop on K Physics, Orsay, France, May 30-June 4, 1996, L. Iconomidou-Fayard, ed., Editions Frontieres, 389-94 (1997).
- S. Kettell (for the E787 collaboration), *E787: A search for the rare decay  $K^0 \rightarrow B^0 \mu^+ \mu^-$* , Proc. 1996 workshop on Heavy Quarks Physics at Fixed Target, Rhinefels Castle, St. Goar, Oct 1996, L. Köpke, Ed., 397 (1997).
- T. Komatsubara, *Progress of the rare decay experiment E787 at BNL-AGS*, High Energy News (Japan), 16, No. 2, 27 (1997) (in Japanese).

**Publications**



- 
- S. Adler, *Status report on the search for  $K^0 \rightarrow B^0 \llcorner$  and prospects for the search for  $K_L^0 \rightarrow B^0 \llcorner$* , Proc. Of 16th Intl. Workshop on Weak Interactions and Neutrinos (WIN 97), 1997).
- D. A. Bryman, et al., *500 MHz transient digitizers based on GaAs CCDs*, Nucl. Instrum. Meth. A396 (1997) 394.
- T. Komatsubara, et al., *Performance of fine mesh photomultiplier tubes designed for an updoped CsI endcap photon detector*, KEK-preprint-97-123, to be pub. In Nucl. Instrum. Meth. A (1997).
- S. Adler, et al., *Evidence for the decay  $K^+ \rightarrow B^0 \llcorner$* , Phys. Rev. Lett 79, 2204, (1997).
- P. Kitching, et al., *Observation of the Decay  $K^+ \rightarrow B^+ \llcorner$* , Phys. Rev. Lett Vol.79, No. 21, 3079, Nov. 24, 1997.
- S. Adler, et al., *Observation of the decay  $K^+ \rightarrow B^+ \mu^+ \mu^-$* , Phys. Rev. Lett., Vol. 79 No. 24, p. 4756-4759, Dec. 15, 1997.
- 788** J.J Szymanski, *Weak Decay of  $7^0$  Hypernuclei*, Proc. of the 2nd Conf. on the Intersections between Particle and Nuclear Physics, Lake Louise, Alberta, Canada, May 24, 1986.
- J.J Szymanski, et al., Phys. Rev. C43, 849 (1991).
- 789** J Sculli, et al., *Limits on  $\Delta(2,2)$  formation in  $p\bar{p} \rightarrow K^0 K^0$* , Phys. Rev. Lett 58, 1715, (1987).
- 790** L.P. Rensberg, et al., *7th High Energy Heavy Ion Study, Stopping power measurements with 17 GeV/c protons at the AGS or inclusive proton spectra from proton-nucleus interactions at 17 GeV/c*, R. Bopck, H.H. Gutbrod, R. Stock (eds.), Gesellschaft für Schwerionenforschung mbH., Darmstadt, FRG, March 1985, pp. 439-450.
- 791** R.D. Cousins, et al., *Search for the decays  $K_L^0 \rightarrow \mu e$  and  $K_L^0 \rightarrow e e$* , Phys. Rev. D38 (Rapid Communications) 2914-2917 (1988).
- C. Mathiazhagan, et al., *New Experimental Limits on  $K_L^0 \rightarrow \mu e$  and  $K_L^0 \rightarrow e e$  Branching Ratios*. Submitted to Phys. Rev. Lett 8/3/89.
- C. Mathiazhagan, et al., *New Experimental Limits on  $K_L^0 \rightarrow \mu e$  and  $K_L^0 \rightarrow e e$  Branching Ratios*, Phys. Rev. Lett 63 2128-2184 (1989).
- C. Mathiazhagen, et al., *Measurement of the Branching Ratio for the Decay  $K_L^0 \rightarrow \mu^+ \mu^-$* , Phys. Rev. Lett 63 2185-2188 (1989).
- A. Heinson, et al., *Higher Statistic Measurement of the Branching Ratio for the Decay  $K_L^0 \rightarrow \mu^+ \mu^-$* , Phys. Rev. D (Rapid Communications), D44, 1-5 (1991).
- K. Arisaka, et al., *Improved Upper Limit on the Branching Ratio  $B(K_L^0 \rightarrow \mu^+ e^-)$* , Phys. Rev. Lett 70, 1044 (1993).
- K. Arisaka, et al., *Improved Sensitivity in a Search for the Rare Decay  $K_L^0 \rightarrow e^+ e^-$* , Phys. Rev. Letts., 71, 3910 (1993).

## Publications

---

- 793** Y. D. He, P. B. Price, and W. T. Williams, *Interactions of projectile fragments at 14.5 A GeV: A search for anomalous*, Phys. Lett. B 252, 331-335 (1990).
- P. B. Price and Y. D. He, *Behavior of nuclear projectile fragments produced in collisions of 14.5 A GeV<sup>28</sup>Si with Pb and Cu targets*, Phys. Rev. C 43, 835-848 (1991).
- Y. D. He and P. B. Price, *Search for fractional charge states in high-energy heavy fragments produced in collisions of 14.5 A GeV<sup>28</sup>Si with Pb and Cu target*, Phys. Rev. C 44, 1672-1674 (1991).
- Y. D. He and P. B. Price, *A Search for fractional charge states in high-energy heavy fragments produced in collisions of 14.5 A GeV<sup>28</sup>Si with Pb and Cu target*, Proc. of 22<sup>nd</sup> Intl. Cosmic Ray Conf., Dublin, 4, 734-737 (1991).
- Y. D. He and P. B. Price, *Sensitivity study of CR-39 plastic track detectors*, Nucl. Tracks Radia. Meas. 20}, 491-494 (1992).
- 794** D.C. Peaslee, et al., *Large  $P_z^2$  spin effects in pp & pp*, Phys. Rev. Lett. 51, 2359 (1983).
- P.R. Cameron, et al., *Measurement of the analyzing power for pp & pp at  $P_z^2 = 6.5 (GeV/c)^2$* , Phys. Rev. D 32, 3070 (1985).
- D.G. Crabb, et al., *High precision measurement of the analyzing power in large  $P_z^2$  spin-polarized 24 GeV/c proton-proton elastic scattering*, Phys. Rev. Lett. 65, 3241 (1990).
- D.G. Crabb, et al., *Observation of a 96% proton polarization in irradiated ammonia*, Phys. Rev. Lett. 64, 2627 (1990),.
- 795** B. Bassalleck, *NN bound states*, Proc. of 1986 INS Intl. Symposium on Hypernuclear Physics, Tokyo, p. 385.
- 796** Y.J. Uemura, et al., *Muon spin relation in CeCu<sup>2</sup>Si<sup>2</sup> and muon knight shift in various heavy-fermion systems*, 4th Int. Conf. on Muon Spin Rotation, Relaxation and Resonance, Uppsala, Sweden, June 1, 1986.
- W. J. Kossler, et al. *Magnetic field penetration depth of La<sub>1.85</sub>Sr<sub>0.15</sub>CuO<sub>4</sub> measured by muon spin relaxation*, Phys. Rev. B, 35, 7133 (1987).
- W. J. Kossler, et al., *Muon spin relaxation on high-T<sub>c</sub> superconductors*, Novel Superconductivity, 757, Stuart A. Wolf and Vladimir Z. Kresin, Editors (Plenum Publishing Corp., 1987).
- Y. J. Uemura, et al., *Antiferromagnetism of La<sub>2</sub>CuO<sub>4-y</sub> Studied by Muon-Spin Rotation*, Phys. Rev. Lett. 59, 1045 (1987).
- Y. J. Uemura, et al., *Systematic variation of magnetic-field penetration depth in high-T<sub>c</sub> superconductors studied by muon-spin relaxation*, Phys. Rev. B, 38 (1988).
- J.H. Brewer, et al., *Antiferromagnetism and superconductivity in oxygen-deficient YBa<sub>2</sub>Cu<sub>3</sub>O<sub>x</sub>*, Phys. Rev. Lett., 60, 1073 (1988).
- Y. J. Uemura, et al., *Comparison between muon spin rotation and neutron scattering studies on the 3-Dimensional Magnetic Ordering of La<sub>2</sub>CuO<sub>4-y</sub>*, Physica C, 769-70 (1988).

- Y. J. Uemura, et al., *Universal Correlations between  $T_c$  and  $n_c/m^*$  (Carrier Density over Effective Mass) in High- $T_c$  Cuprate Superconductors*, Phys. Rev. Lett. 62, 2317 (1989).
- W. J. Kossler, et al., *Coexisting static magnetic order and superconductivity in  $CeCu_{2.1}Si_2$  found by muon spin relaxation*, Phys. Rev. B., 39, 4726 (1989).
- 798** H. S. Plendl, *Excitation of Hypernuclear States Through the  $(B^+, K^+)$  Reaction*, Proc. of the 4th Intl. Conf. on Nuclear Reaction Mechanisms, Varenna, June 10-15, 1985. Ed. E. Gadioli.
- R. E. Chrien, Nucl. Phys. A478 (1988) 705c.
- P. H. File, J. Phys. Soc. Japan. 58 (1989) Suppl. p. 394.
- P. H. File, *A Study of Heavy Hypernuclei Using the  $(B^+, K^+)$  Reaction*, IL Nuovo Cimento, Vol. 102, No. 2, p. 413 (1989).
- P. H. File,  *$B^+, K^+$  experimental difficulties*, BNL-45637-m c (microfiche), Submitted to Workshop on (B, K) Physics, Los Alamos, NM, Oct 10, 1990. Pub. in LAMPFBK workshop 1990, p.77-85 (QCD 161:L2:1991).
- P. H. File, et al., *Study of Hypernuclei by Associated Production*, Phys. Rev. Letts. 66, 2585-1258 (1991).
- 801** G. L. Shaw, et al., *Search for Free Quarks Produced by 14.5 GeV/A Heavy Ions*, submitted to Phys. Rev. Letts. 1987.
- Gordon L. Shaw, et al., *Search for free quarks produced by 14.5 GeV/nucleon oxygen ions*, Phys. Rev. D, 36, 3533 1987.
- 802** T. Abbott, et al., *Measurement of energy emission from  $O^+ A$  and  $p^+ A$  collisions at 14.5 GeV/c per nucleon with a lead-glass array*, Phys. Lett. 197, 285-90 (1987).
- T. Abbott, et al., *First encounter with a 14.5 GeV/A  $^{16}O$  beam*. Proc. XI International Conference on Particle and Nuclei (PANIC '87), Kyoto, Japan, April 20-24, 1987 (Abstract Book Part II), edited by S. Homma *et al.*, pp. 448-9 (1987).
- D. E. Alburger, et al.,  *$CsI(Tl)-^{241}Am$  calibration source for Pb-glass detectors*, Nucl. Instr. and Meth. A254, 88 (1987).
- D. E. Alburger, *Removal of phototubes from Pb-glass detectors*, Rev. Sci. Instrum. 58, 143 (1987).
- D. E. Alburger and M. J. Tannenbaum, *Removal of phototubes from Pb-glass detectors II*, Rev. Sci. Instrum. 58, 1761 (1987).
- M. J. LeVine, W. A. Watson III, H. von der Schmitt, and S. Kaufman, *Distributed data acquisition for BNL 802 I: the front end*, Fifth Conf. on Real-Time Computer Applications in Nuclear, Particle and Plasma Physics, San Francisco, CA, May 11-15, 1987, IEEE Trans. Nucl. Sci. NS-34, 830 (1987).
- R. A. Scheetz and M. J. LeVine, *An intelligent VME-based camac crate controller*, Fifth Conf. on Real-Time Computer Applications in Nuclear, Particle, and Plasma Physics, San Francisco, CA, May 11-15, 1987, IEEE Trans. Nucl. Sci. NS-34, 1033 (1987).

## Publications

---

R.A. Scheetz and M.J. LeVine, *A VME-VMX interface to fastbus via the LeCroy 1821 segment manager*, Fifth Conf. on Real-Time Computer Applications in Nuclear, Particle, and Plasma Physics, San Francisco, CA, May 11-15, 1987, IEEE Trans. Nucl. Sci. NS-34, 1036 (1987).

B. Wadsworth, et al., *The trigger supervisor: managing triggering conditions in a high energy physics experiment*, Fifth Conf. on Real-Time Computer Applications in Nuclear, Particle, and Plasma Physics, San Francisco, CA, May 11-15, 1987, IEEE Trans. Nucl. Sci. NS-34, 980 (1987).

T. Abbott, et al., *Measurement of energy and charged particle emission in the central rapidity region from  $O+ A$  and  $p+ A$  collisions at 14.5 GeV/c per nucleon and preliminary results from  $Si+ A$  collisions*. Proc. 6th Intern. Conf. on Ultra-Relativistic Nucleus-Nucleus Collisions, August 24-28, 1987, Schloss-Nordkirchen, W. Germany. Z. Phys. C 38, 35-43 (1988).

T. Abbott, et al., *Preliminary spectrometer results from E802*, Proc. 6th Int. Conf. on Ultra-Relativistic Nucleus-Nucleus Collisions (Quark Matter 1987), Z. Phys. C 38, 135-9 (1988).

T. Abbott, et al., *Measurement of energy and charged particle emission in the central rapidity region from  $O+ A$  and  $p+ A$  collisions at 14.5 GeV/c per nucleon and preliminary results from  $Si+ A$  collisions*, Proc. 6th Int. Conf., on Ultra-Relativistic Nucleus-Nucleus Collisions (Quark Matter 1988), Z. Phys. C.

T. Abbott, et al., *Proton production from  $Si+ Au$  collisions at 14.5 A • GeV*, Proc. 7th Int. Conf. on Ultra-Relativistic Nucleus-Nucleus Collisions (Quark Matter 1988), Z. Phys. C.

T. Abbott, et al., *Particle spectra near mid-rapidity studied with a Cherenkov-complex system in 14.5 A GeV  $Si+ Au$  collisions*, Proc. 7th Int. Conf. on Ultra-Relativistic Nucleus-Nucleus Collisions (Quark Matter 1988), Z. Phys. C.

T. Abbott, et al., *Preliminary results from Brookhaven experiment 802 with 14.5 GeV/u  $^{28}Si$* . Proc. IX Autumn School on the Physics of Quark-Gluon Plasma, December 9-12, 1987, Lisbon, Portugal. J. Dias de Deus and S. Costa Ramos, editors, World Scientific Publishing Co., Pte. Ltd., New Jersey, pp. 3-14 (1988).

T. Abbott, et al., *Preliminary spectrometer results from E802*. Proc. 6th Intern. Conf. on Ultra-Relativistic Nucleus-Nucleus Collisions, Aug. 24-28, 1987, Schloss-Nordkirchen, Germany. Z. Phys. C 38, 135-9 (1988).

T. Abbott, et al., *Projectile energy degradation at 14.5 GeV/u*. Proc. Third Int. Conf. on Nucleus-Nucleus Collisions, June 6-11 1988, Saint-Malo, France.

T. Abbott, et al. *Spectrometer results from BNL E802*. Proc. 3rd Conf. on the Intersections Between Particle and Nuclear Physics, May 14-19, 1988, Rockport, ME. G.M. Bunce, Editor, AIP Conference Proceedings 176, 1988, pp. 1060-7.

M.J. Tannenbaum, et al., *Measurement of energy flow from oxygen, silicon and proton inter-actions with nuclei at the BNL Tandem-AGS*. Proc. XXIII Rencontre Moriond, Current Issues in Hadron Physics, Les Arcs, Savoie, France, March 1988.

P. Vincent, et al., *The E802 aerogel Cherenkov detector*, Nucl. Inst. and Meth. A272, 660 (1988).

T. Abbott, et al., *Proton production from  $Si+ Au$  collisions at 14.5 A GeV*. Proc. 7th Intern. Conf. on Ultra-Relativistic Nucleus-Nucleus Collisions, Sept. 26-30, 1988, Lenox, MA. Nucl. Phys. A498, 409c-13c (1989).

**Publications**

- T. Abbott, et al., *Particle spectra near mid-rapidity studies with a Cherenkov-complex system in 14.5 A GeV Si + Au collisions*. Proc. 7th Intern. Conf. on Ultra-Relativistic Nucleus-Nucleus Collisions, September 26-30, 1988, Lenox, MA. Nucl. Phys. A498, 415c-9c (1989).
- T. Abbott, et al., *Results from the BNL E802 spectrometer for 14.5 GeV/c per nucleon Si beams*. Proc. 7th Intern. Conf. on Ultra-Relativistic Nucleus-Nucleus Collisions, Sept 26-30, 1988, Lenox, MA. Nucl. Phys. A498, 67c-78c (1989).
- T. Abbott, et al., *Results for strange production from BNL E802*, Proc. Hadronic Matter in Collision, Oct 6-12, 1988, Tucson, AZ. P. Carruthers and J. Rafelski, Editors, World Scientific, pp. 607-16 (1989).
- T. Abbott, et al., *BNL high energy heavy ion experiments*, Proc. 5th French-Japanese Symposium on Nuclear Physics, Sept 26-30, 1989, Dogashima, Japan, pp. 33-41 (1989).
- T. Abbott, et al., *Survey of results from Brookhaven experiment 802 at the AGS*. Proc. Symp. on Nuclear Dynamics and Nuclear Disassembly, American Chemical Society, April 10-14, 1989, Dallas, TX. J.B. Natowitz, Ed., World Scientific, pp. 507-16 (1989).
- D. Alburger, et al., *Response of a thin avalanche detector to simultaneous minimum ionizing particles*, Nucl. Instr. and Meth. A276, 127 (1989).
- D. Beavis, et al., *A calorimeter for relativistic heavy-ion experiments*, Nucl. Instr. Meth. A281, 367-72 (1989).
- J.B. Cumming, et al., *More on ZCAL's response: position dependence, position determination, and collimation effects*. BNL Informal Report, BNL-43537 (1989). R. Debbe, J. Fischer, D. Lissauer, T. Ludlam, D. Makowiecki, V. Radeka, S. Rescia, G.C. Smith, D. Stephani, D. Yu. M.W.P.C. with highly segmented cathode pad readout. Proc. 1989 Wire Chamber Conference, February 13-17, 1989, Vienna, Austria. Nucl. Instr. Meth. A283, 772-7 (1989).
- H. Wegner, et al., (*E-802 Collaboration*), *p + A and comparison to  $^{28}\text{Si} + A$  measurements with the E-802 relativistic heavy ion spectrometer*, Proc. 1989 Intl. Nuclear Physics Conf., August 20-26, 1989, Sao Paulo, Brazil.
- T. Abbott, et al., *Kaon and pion production in central Si+ Au collisions at 14.6 A GeV/c*, Phys. Rev. Letts. 64, 847-50 (1990).
- T. Abbott, et al., *A single arm spectrometer detector system for high energy heavy ion experiments*, Nucl. Instr. Meth. A 290, 41-60 (1990).
- R. Debbe, et al., *A study of wire chambers with highly segmented cathode pad readout for high multiplicity, charged particle detection*. IEEE Nuc. Sci. Symposium, Jan. 17-19, 1990, San Fran., CA. IEEE Trans. Nucl. Sci. 37, 88-94 (1990)
- O. Hansen, *Strangeness production in Si+ Au interactions at 14.6 GeV/c per nucleon*. Proc. International Advanced Courses on the Nuclear Equation of State, May 21-June 3, 1989, Pensicola, Spain, "The Nuclear Equation of State, Part B, edited by W. Greiner and H. Stöcker, pp. 97-102, Plenum Press, New York (1990).

## Publications

---

- O. Hansen, *Are hadron spectra thermal in 14.6 A GeV/c nucleus-nucleus collisions?* Proc. 6th Nordic Meeting

on Nuclear Physics, August 10-15, 1989, Utgarden, Kopervik, Norway. *Physica Scripta* T32, 143-6 (1990).

Ole Hansen, *Strangeness enhancement in 14.6 A GeV/c Si+ Au interactions?* Proc. Int. Workshop XVIII Gross Properties of Nuclei and Nuclear Excitations, January 15-20, 1990. Hirschegg, Austria, pp. 63-70 (1990).

Ole Hansen, Editor. Proc. Workshop on Heavy Ion Physics at the AGS (HIPAGS), March 5-7, 1990, Brookhaven National Laboratory, Upton, NY. BNL-44911 (1990).

Y. Miake, et al., (E-802 Collaboration). *Spectra and strangeness production.* Proc. Workshop on Heavy Ion Physics at the AGS (HIPAGS), March 5-7, 1990, Brookhaven National Laboratory, Upton, NY. BNL-44911, pp. 240-8 (1990).

Y. Miake, *Review of BNL heavy ion physics.* Proc. Intern. Workshop on High Density Nuclear Matter, September 18-21, 1990, KEK, Ibaraki, Japan (in press).

M.J Tannenbaum, et al., (E-802 Collaboration).  *$E_T$  distributions, "nuclear stopping," and correlations among measurements from the 4 detector systems in AGS E802.* Proc. Workshop on Heavy Ion Physics at the AGS (HIPAGS), March 5-7, 1990, Brookhaven National Laboratory, Upton, NY. BNL-44911, pp. 44-69 (1990).

F. Videbaek, et al., (E-802 Collaboration). *Charged particle distributions in heavy ion collisions at 14.6 GeV A/c.* Proc. Workshop on Heavy Ion Physics at the AGS (HIPAGS), March 5-7, 1990, Brookhaven National Laboratory, Upton, NY. BNL-44911, pp. 38-43 (1990).

J. Costales, et al., (E-802 Collaboration). *E802: baryons and anti-baryons.* Proc. Workshop on Heavy Ion Physics at the AGS (HIPAGS), March 5-7, 1990, Brookhaven National Laboratory, Upton, NY. BNL-44911, pp. 249-60 (1990).

R.J Morse, et al., (E-802 Collaboration). *E802 HBT results.* Proc. Workshop on Heavy Ion Physics at the AGS (HIPAGS), March 5-7, 1990, Brookhaven National Laboratory, Upton, NY. BNL-44911, pp. 402-10 (1990).

M.J LeVine, *New challengers for HEP computing: RHIC and CEBAF.* Proc. Computing in High Energy Physics-1990, Santa Fe, NM. AIP Conference Proceedings 209, J. Lillberg and M. Othoudt, Editors, pp. 31-43 (1990).

T. Abbott, et al., *Antiproton Production in 14.6 A GeV/c Si + A Collisions,* submitted to *Phys. Lett.* B271, 447-52 (1991).

T. Abbott, et al., *Forward and Transverse Energies in Relativistic Heavy Ion Collisions at 14.6 GeV/c per Nucleon,* *Phys. Rev. C* 44, 1611-9 (1991).

T. Abbott, et al., *Comparison of  $p+$  A and  $Si+$  Au Collisions at 14.6 GeV/c.* *Phys. Rev. Letts.* **66**, 1567-70 (1991).

M.A. Bloomer, et al., (E-802 Collaboration). Love, W. et al (E-810 Collaboration), and L. Waters (E-814 Collaboration). *New results from AGS heavy-ion experiments.* *Nucl. Phys.* A527, 595c-600C (1991).

## Publications

---

J.B. Costales, et al., (E-802 Collaboration). *Antiproton production in 14.6 A GeV/c Si + A collisions.* Proc.

- Quark Matter 1990, May 7-11, 1990, Menton, France. Nucl. Phys. A525, 455c-8c (1991).
- J.B. Costales, et al., (E-802 Collaboration). *Target rapidity proton distributions for Si+ A collisions at the AGS*. Proc. Quark Matter 1991, November 11-15, 1991, Gatlinburg, TN (in press).
- O. Hansen, *On the Quark-Gluon Plasma and Strangeness Enhancement*. Comments Nucl. Part Phys., Vol. 20, Nos. 1 & 2, pp. 1-14 (1991).
- Ole Hansen, *Nucleus-nucleus collisions at very high energies*. Proc. Mikolajki Summer School on Nuclear Physics, August 25-September 5, 1990, Mikolajki, Poland in "Nuclear and Atomic Physics with the Accelerators of the Nineties," Editors, A. Sujkowski and G. Szeffinska, IOP Publishing, Ltd, pp. 1-18 (1991).
- Y. Miake, et al., (E-802 Collaboration). *Particle production in Si + A and p + A collisions at 14.6 A@ GeV/c*. Proc. Quark Matter 1990, May 7-11, 1990, Menton, France. Nucl. Phys. A525, 231c-6c (1991).
- R.J. Morse, et al., (E-802 Collaboration). *Bose-Einstein correlations in 14.6 A@ GeV/c <sup>28</sup>Si + A collisions*. Proc. Quark Matter 1990, May 7-11, 1990, Menton France. Nucl. Phys. A525, 531c-5c (1991).
- B. Moskowitz, et al., (E-802 Collaboration). *A review of recent E802 results*. Proc. Seventh Winter Workshop on Nuclear Dynamics, January 26-February 2, 1991, Key West, FL.
- M.J. Tannenbaum, et al., (E-802 Collaboration). *Transverse energy and multiplicity distributions of p+ p and A+ A interactions*. Proc. Quark Matter 1990, May 7-10, 1990, Menton, France. Nucl. Phys. A525, 681c-4c (1991).
- F. Videbaek, et al., (E-802 Collaboration). *Particle production and spectra in E-802 at BNL-AGS*. Proc. Int. Symp. of High Energy Nuclear Collisions and Quark Gluon Plasma, June 6-8, 1991, Kyoto, Japan.
- W.A. Zajc, et al., (E-802 Collaboration). *Recent results from E802 and E859*. Proc. Quark Matter 1991, November 11-15, 1992, Gatlinburg, TN..
- T. Abbott, et al., *Bose-Einstein Correlations in Si + Al and Si + Au Collisions at 14.6 A GeV/c*. Phys. Rev. Letts. 69, 1030-3 (1992).
- T. Abbott, et al., *Measurement of Particle Production in Proton Induced Reactions at 14.6 GeV/c*. Phys. Rev. D 45, 3906-20 (1992).
- T. Abbott, et al., *Centrality dependence of K<sup>+</sup> and B<sup>+</sup> multiplicities from Si+ A collisions at 14.6 A@ GeV/c*. Phys. Lett. B 291, 341-6 (1992).
- T. Abbott, et al., *Global transverse energy distributions in relativistic nuclear collisions at 14.6 A@ GeV/c*. Phys. Rev. C 45, 2933-51 (1992).

## Publications

---

- B. Moskowitz, O. Hansen and F. Videbaek. *An "in acceptance" comparison of Si + Au data and RQMD predictions*. Proc. Gross Properties of Nuclei and Nuclear Excitations International Workshop XX, January 20-25, 1992, Hirschegg, Kleinwalsertal, Austria.
- T. Abbott, et al., *Multiplicity Distributions from Central Collisions of <sup>16</sup>O + Cu at 14.6 A GeV/c and Inter-*

mittency. Accepted by Phys. Rev. C, September 7, 1995.

- 805** S. De Panfilis, et al., *First Results from the Galactic Axion Search*, Proceedings of the 13th Texas Symposium on Relativistic Astrophysics, M. Ulmer, et al., (World Scientific, 1987) p. 265.
- S. DePanfilis, et al., *Limits on the Abundance and Coupling of Cosmic Axions at  $4.5 < m_a < 5.0 \mu e V$* , Phys. Rev. Letts. 59, 839 (1987).
- S. De Panfilis, et al., *Limits on the Abundance and Coupling of Cosmic Axions*. Neutrino Masses and Neutrino Astrophysics, Proceedings of the IV Telemark Conference, V. Barger, F. Halzen, M. Marshak, and K. Olive, ed. (World Scientific, 1987).
- S. De Panfilis and J. Rogers, *L and S Band Low-Noise Cryogenic GaAsFET Amplifiers*. IEEE Trans. Microwave Theory and Techniques (March 1988).
- S. De Panfilis, et al., *An Update of Results from an Experiment to Search for Galactic Axions Proceedings of II Workshop on Low Temperature Devices for Detection of Low Energy Neutrinos and Dark Matter*, L.A.P.P. (Annecy, France), May, 1988.
- B.E. Moskowitz, *Cosmic Axion Searches*. Proceedings of the Workshop on Non-Accelerator Particle Physics, A.C. Melissinos and B.E. Moskowitz, eds., NIM A264, 98 (1988).
- B.E. Moskowitz and J. Rogers, *Analysis of a Microwave Cavity Detector Coupled to a Noisy Amplifier*. Nuclear Instruments and Methods A264, 445 (1988).
- B.E. Moskowitz, et al., *Improved Limits from the Galactic Axion Search*, Proceedings of the II ESO/CERN Symposium on Astronomy, Cosmology, and Fundamental Physics, (Bologna, Italy) May, 1988, G. Giacomelli, ed.
- J.T. Rogers, et al., *Anomalous r.f Magneto Resistance in Copper at 4°K*, Applied Physics Letters 52, 2266 (1988).
- A.C. Melissinos, et al., *Search for Cosmic Axions*, Eighth Workshop on Grand Unification, K.C. Wali, Ed., World Scientific, 1988.
- W. Wuensch, et al., *Search for Cosmic Axions*, Proceedings of XXIII Rencontre de Moriond on Dark Matter (Les Arcs, France) 1988. J. Tran Than Van, ed.
- W.U. Wuensch, et al., *Results of a Laboratory Search for Cosmic Axions and Other Weakly Coupled Light Particles*, " Phys. Rev. D40, 3153 (1989).
- J.T. Rogers, et al., *Experience with the Rochester-Brookhaven-Fermilab Axion Detector*, Proceedings of the Workshop on Cosmic Axions (BNL 1989), C. Jones & A.C. Melissinos, eds., World Scientific, p.39 (1990).

## Publications

---

- 806** C. Brechtmann, W. Heinrich, Nucl. Instr. Meth. B, 29 (1988).
- A. Hoffmann, C. Brechtmann, W. Heinrich, E.V. Benton, *Search for Projectile Fragments with Fractional Charge in Relativistic Heavy Ion Collisions*. Phys. Letts. B, Vol. 200, No. 4, 21 Jan. 1988).



- C. Brechtmann, W. Heinrich, and E.V. Benton, *Fragmentation Cross Sections of  $^{28}\text{Si}$  at 14.5 GeV/Nucl*, Phys. Rev. C 39, (1989).
- W. Heinrich, C. Brechtmann, *Electromagnetic Dissociation in Ultra-relativistic Heavy Ion Reactions*, Mod. Phys. Lett A 4, 1879-1882 (1989).
- 808** L.M. Barbier, et al., *Central collisions of 14.6, 60, and 200 GeV/nucleon  $^{16}\text{O}$  nuclei in nuclear emulsion*, Phys. Rev. Lett. Vol. 60, No. 5, 405 (1988).
- L.M. Barbier, et al., *Nucleus-Nucleus Interactions at 14.6, 60 and 200 GeV/nucleon*, Nuclear Physics A498, 535c-540c (1989).
- H. von Gersdorff, et al., *Single-particle and multi-particle analysis of nucleus-nucleus collisions at 14.6, 60 and 200 GeV/nucleon*, Phys. Rev. C, 39, No. 4, 1385 (April 1989).
- R. Holynski, et al., *Evidence of Intermittent Patterns of Fluctuations in Particle Production in High Energy Interactions in Nuclear Emulsion*, Phys. Rev. Lett., Vol. 62, 733 (1989).
- R. Holynski, et al., *One- and two-dimensional analysis of the factorial moments in 200 GeV/nucleon p,  $^{16}\text{O}$  and  $^{32}\text{S}$  interactions with Ag and Br nuclei*, Phys. Rev. C, Vol. 40, No. 6 (1989).
- J.F. Amundson, *Intermittency and relativistic heavy-ion Monte Carlo simulators*, Phys. Rev. C 41, 1292 (1990).
- C.J. Waddington, et al., *Energy dependence of fragmentation of oxygen nuclei up to 200 GeV/nucleon*, 21<sup>st</sup> International Cosmic Ray Conference, University of Adelaide, Australia, 8, 87 (1990).
- 810** S.J. Lindenbaum, et al., *Search for QGP Signals at AGS with a TPC Spectrometer, and Comparison of Our Event Generator Predictions for Plasma Model and Cascade Interactions*. Proc. of the Third Conference on the Intersections Between Particle and Nuclear Physics, May 14-19, 1988, Rockport, Maine. AIP Conference Proceedings 176, pp. 778-786 (1988).
- Kenneth J. Foley, *The Use of TPC's as Target Region Detectors in the MPS*. Proc. of the 1988 BNL Workshop on Glueballs, Hybrids and Exotic Hadrons, August 29-September 1, 1988, Brookhaven Natl. Laboratory, AIP Conference Proceedings 185, Suh-Urk Chung, Editor, p. 643-645.
- W.A. Love (The E810 Collaboration), *Some TPC Measurements in an Oxygen Beam at the AGS*. Proc. of the VII International Conference on Ultra-Relativistic Nucleus- Nucleus Collisions (Quark Matter 88) Lenox, Massachusetts, Sept. 26-30, 1988. G.A. Baym, P. Braun-Munzinger, S. Nagamiya, Eds., Nucl. Phys. A498, 523c-528c (1989).
- A. Etkin, et al., *A TPC for Large Solid Angle Relativistic Ion Experiments*. Proc. of the 1988 IEEE Nuclear Science Symposium, Orlando, Florida, November 9-11, 1988, IEEE Transactions on Nuclear Science 36, pp. 58-62 (1989).

## Publications

---

- A. Etkin, et al., *Modular TPC's for Relativistic Heavy Ion Experiments*, Proc. of the Wire Chamber Conference, Vienna, Austria, Feb.13-17, 1989, Nuclear Instruments and Methods in Physics Research A283, 557-566 (1989).
- S.J. Lindenbaum, *Search for a QGP with a TPC Spectrometer, and QGP Signals Predicted by New Event*

*Generator*, Proc. of the Hadronic Matter in Collision Conference, Tucson, AZ, Oct 6-12, 1988, P. Carruthers and J. Rafelski, Editors, pp. 673-692 (World Scientific, 1989).

K.J. Foley, et al., *Studies of Multiparticle Production in Heavy Ion Collisions Using a Time Projection Chamber*, Proc. of the Europhysics Conference on High Energy Physics, 6-13 Sept. 1989, Madrid, Spain. Nucl. B (Proc. Suppl.) 16, 405-406 (1990).

Alfred C. Saulys (for the E810 Collaboration: B.E. Bonner, J.A. Buchanan, C.S. Chan, C.N. Chiou, J.M. Clement, M.D. Corcoran, A. Etkin, K.J. Foley, R.W. Hackenburg, T.J. Hallman, M.A. Kramer, J.W. Kruk, S.J. Lindenbaum, R.S. Longacre, W.A. Love, L. Madansky, H.E. Miettinen, T.W. Morris, G.S. Mutchler, M. Nessi, F. Nessi-Tedaldi, E.D. Platner, J.B. Roberts and A.C. Saulys).  *$V^0$  Production with 14.5 GeV/c Silicon Beams*. Proc. of the Workshop on Heavy Ion Physics at the AGS, Brookhaven National Laboratory, March 5-7, 1990, Editor: Ole Hansen, pp. 209-226 (BNL, 1990).

William A. Love (for the E810 Collaboration: B.E. Bonner, J.A. Buchanan, C.S. Chan, C.N. Chiou, J.M. Clement, M.D. Corcoran, A. Etkin, K.J. Foley, R.W. Hackenburg, T.J. Hallman, M.A. Kramer, J.W. Kruk, S.J. Lindenbaum, R.S. Longacre, W.A. Love, L. Madansky, H.E. Miettinen, T.W. Morris, G.S. Mutchler, M. Nessi, F. Nessi-Tedaldi, E.D. Platner, J.B. Roberts, and A.C. Saulys). *AGS Silicon Gold Collisions Measured in the E810 TPC*. Proc. of the Workshop on Heavy Ion Physics at AGS, Brookhaven National Laboratory, March 5-7, 1990, Ole Hansen, Editor, pp. 27-37 (BNL, 1990).

E.D. Platner (for the E810 Collaboration: A. Etkin, K.J. Foley, R.W. Hackenburg, R.S. Longacre, W.A. Love, T.W. Morris, E.D. Platner, A.C. Saulys, S.J. Lindenbaum, C.S. Chan, M.A. Kramer, T.J. Hallman, L. Madansky, B.E. Bonner, J.A. Buchanan, C.N. Chiou, J.M. Clement, M.D. Corcoran, J.W. Kruk, H.E. Miettinen, G.S. Mutchler, F. Nessi-Tedaldi, M. Nessi, J.B. Roberts). *E810 Future Plans*. Proc. of the Workshop on Heavy Ion Physics at AGS, Brookhaven National Laboratory, March 5-7, 1990, Ole Hansen, Editor, pp. 227-239 (BNL 1990).

T. Hallman, et al., *First Observation of  $7^0$ ,  $\bar{7}^0$ ,  $K_S^0$  Production in Relativistic Heavy Ion Collisions at the AGS*. Proc. of the Workshop on Heavy Ion Physics at AGS, Brookhaven National Lab., March 5-7, 1990, O. Hansen ed., pp. 182-192 (BNL 1990).

S. Eiseman, et al., *Neutral  $V$  Production with 14.6 x A Silicon Beams*. Phys. Lett. B248, 254-258 (1990).

K.J. Foley (for the E810 Collaboration: S. Eiseman, A. Etkin, K.J. Foley, R.W. Hackenburg, R.S. Longacre, W.A. Love, T.W. Morris, E.D. Platner, A.C. Saulys, S.J. Lindenbaum, C.S. Chan, M.A. Kramer, K. Zhao, T.J. Hallman, L. Madansky, B.E. Bonner, J.A. Buchanan, C.N. Chiou, J.M. Clement, M.D. Corcoran, J.W. Kruk, G.S. Mutchler, F. Nessi-Tedaldi, M. Nessi, J.B. Roberts). *Studies of Central Interactions of Si Ions at 14.5 x A GeV/c in Au and Cu*. Submitted to the 25th Intern. Conf. on High Energy Physics, Singapore, August 2-8, 1990.

## Publications

---

Kenneth J. Foley (for the E810 Collaboration: B.E. Bonner, J.A. Buchanan, C.S. Chan, C.N. Chiou, J.M. Clement, M.D. Corcoran, S.E. Eiseman, A. Etkin, K.J. Foley, R.W. Hackenburg, T.J. Hallman, M.A. Kramer, J.W. Kruk, S.J. Lindenbaum, R.S. Longacre, W.A. Love, L. Madansky, T.W. Morris, G.S. Mutchler, E. Nessi-Tedaldi, M. Nessi, E.D. Platner, J.B. Roberts, A.C. Saulys, and K. Zhao). *Studies of Neutral  $V$  Production by Si Ions at 14.5 x A GeV/c in Au and Cu*. Proc. of the 25th Intern. Conf. on High Energy Physics, Singapore, August 2-8, 1990, K.K. Phua and Y. Yamaguchi, Eds., pp. 1092-1093 (South East

Asia Theoretical Physics Assoc., Physical Society of Japan and co-sponsoring associations).

William A. Love (for the E810 Collaboration: B.E. Bonner, J.A. Buchanan, C.S. Chan, C.N. Chiou, J.M. Clement, M.D. Corcoran, S.E. Eisman, A. Etkin, K.J. Foley, R.W. Hackenburg, T.J. Hallman, M.A. Kramer, J.W. Kruk, S.J. Lindenbaum, R.S. Longacre, W.A. Love, L. Madansky, T.W. Morris, G.S. Mutchler, M. Nesi, F. Nesi-Tedaldi, E.D. Platner, J.B. Roberts, A.C. Saulys, K. Zhao. *Silicon Ion Interactions Measured in the E810 TPC at the AGS*. Proc. of QUARK MATTER 90, Menton, France, May 7-11, 1990, J.P. Blaizot, C. Gerschel, B. Fre, A. Romana, Eds. Nuclear Physics A525, 601c-604c (1991).

Matthew A. Bloomer, William Love, Laurie Waters. *New Results from AGS Heavy-Ion Experiments*. Proc. of QUARK MATTER 90, Menton, France, May 7-11, 1990, J.P. Blaizot, C. Gerschel, B. Fre, A. Romana, Eds. Nuclear Physics A525, 601c-604c (1991).

S.E. Eisman, A. Etkin, K.J. Foley, R.W. Hackenburg, R.S. Longacre, W.A. Love, T.W. Morris, E.D. Platner, A.C. Saulys, S.J. Lindenbaum, C.S. Chan, M.A. Kramer, K. Zhao, T.J. Hallman, L. Madansky, B.E. Bonner, J.A. Buchanan, C.N. Chiou, J.M. Clement, G.S. Mutchler, J.B. Roberts. *An Experiment to Observe Strange Particle Production in Ion Collisions at the AGS*. High Energy Nuclear Collisions & Quark Gluon Plasma. M. Biyajima, H. Enyo, T. Kunihiro, O. Miyamura, Eds., Proc. of the Intern. Symposium on High Energy Nuclear Collisions and Quark Gluon Plasma, Kyoto, Japan, June 6-8, 1991 pp. 62-68.

S.J. Lindenbaum (for the E-810 Collaboration: D.L. Adams, S. Ahmad, B.E. Bonner, J.A. Buchanan, C.S. Chan, C.N. Chiou, J.M. Clement, M.D. Corcoran, S.E. Eisman, T. Empl, A. Etkin, K.J. Foley, R.W. Hackenburg, T.J. Hallman, M.A. Kramer, S.J. Lindenbaum, R.S. Longacre, W.A. Love, L. Madansky, H.E. Miettinen, T.W. Morris, G.S. Mutchler, E.D. Platner, J.B. Roberts, A.C. Saulys, J. Skeens, K. Zhao, Y. Zhu. *Results on Search for a QGP with a TPC Magnetic Spectrometer at AGS and Plans for an. 4B TPC Magnetic Spectrometer at RHIC*. Advances in Nuclear Dynamics NAMICS (Proc. of the 7th Winter Workshop on Nuclear Dynamics, Key West, Fla., Jan. 26-Feb. 2, 1991). W. Bauer and J. Kapusta, Eds. pp. 68-78 (World Scientific, 1991).

A. Etkin, et al., *Behavior of TPC's in a High Particle Flux Environment*. Proc. of the Symposium on RHIC Detector R&D, Brookhaven National Laboratory, October 10-11, 1991. Y. Makdisi and A.J. Stevens, Eds. pp. 207-213 (BNL, 1991).

S. Ahmad, et al., *A Silicon Multiplicity Detector System for an Experiment on the Interaction of Antiprotons with Nuclei at BNL*. Conference Record of the 1991 IEEE Nuclear Science Symposium and Medical Imaging Conf., Nov. 2-9, 1991, Santa Fe, NM, Vol.1, pp. 377-380. (1991); and IEEE Transactions on Nuclear Science, Vol. 39, No. 4 (1992) 615-618.

S. Ahmad, et al., *Transverse Momentum Distributions of B from 14.6 x A GeV/c Silicon Ion Interactions in Copper and Gold*. Phys. Lett. B281, 29-32 (1992).

## Publications

---

L. Madansky, et al., *Recent Results from E810*. (Proceedings of Quark Matter 1991.) Nuclear Physics A544 (1992) 335c-342c.

S.E. Eisman, et al., *Rapidity Distributions and Nuclear Transparency in Heavy Ion Collisions*. Phys. Lett. B292, 10-12 (1992).

A. Etkin, et al., *Behavior of TPC's in a High Particle Flux Environment*, Conference Record of the 1991 IEEE Nuclear Science Symposium and Medical Imaging Conference, November 2-9, 1991, Santa Fe, NM, Vol. 1, pp. 537-541 (1991); and IEEE Transactions on Nuclear Science, Vol. 39 No. 4 (1992) 696-700.

A. Etkin, et al., *Effects of High Beam Rates on TPC's*. Proc. of the 6th Wire Chamber Conference, Vienna, Austria, Feb. 17-21, 1992), Nucl. Instruments and Methods in Physics Research A323 (1992) 224-227.

S.J. Lindenbaum (for the E810 Collaboration: A. Etkin, S.E. Eiseman, K. J. Foley, R. W. Hackenburg, R.S. Longacre, W.A. Love, T.W. Morris, E.D. Platner, A.C. Saulys, S.J. Lindenbaum, T.J. Hallman, C.S. Chan, E. Efsthadiadis, M.A. Kramer, K. Zhao, Y. Zhu, L. Madansky, S. Ahmad, B.E. Bonner, J.A. Buchanan, C.N. Chiou, J.M. Clement, G.S. Mutchler). *Rapidity Distributions of  $K_s^0$  and  $\Lambda$ 's Produced by 14.6 GeV/c Si Beams on Si and Pb Targets*. Paper submitted to the 26th Intern. Conf. on High Energy Physics (ICHEP 92), August 6-12, 1992, Dallas, Texas.

S.E. Eiseman, et al., *Rapidity Distributions of  $K_s^0$ 's and  $\Lambda$ 's Produced by 14.6 x A GeV/c Si Beams on Si and Pb Targets*, Phys. Lett. B297 (1992) 44-48.

**811** E.C. Booth, et al., *A Study of Radiative Hyperon Processes at Brookhaven*, XI International Conference on Particles and Nuclei, Kyoto, 20-24 April 1987.

D.A. Whitehouse, et al., *Radiative Kaon Capture in Hydrogen*, Bull. Am. Phys. Soc. 33, 1022 (1988).

K.P. Gall, et al., *Radiative Kaon Capture in Deuterium*, Bull. Am. Phys. Soc. 33, 1022 (1988)

B.L. Roberts, et al.,  *$E^+$  Weak Radiative Decay*, Bull. Am. Phys. Soc. 33, 1022 (1988).

B.L. Roberts, et al., *Radiative Kaon Capture and Hyperon Weak Radiative Decay*, Nucl. Phys. A479, 75c (1988).

A. J. Noble, et al.,  *$\Lambda$  and  $G^+$  Weak Radiative Decay*, Proc. of the Third Conference on the Intersection of Particle and Nuclear Physics, Rockport ME, 14-19 May, 1988, AIP Conf. Proc. 176, 842 (1988).

E.K. McIntyre, et al., *Radiative Kaon Capture*, Proc. of the Third Conference on the Intersection of Particle and Nuclear Physics, Rockport ME, 14-19 May 1988, AIP Conference Proc. 176, 673 (1988).

D. Horváth, et al., *Experimental Study of Radiative Hyperon Processes following Kaon Capture on the Proton*, Int. Conf. on Mesons & Light Nuclei, Bedujné, Czechoslovakia, August 1988.

E.K. McIntyre, et al., *Radiative Kaon Capture in Hydrogen*, Excited Baryons 88, August 1988, RPI, Troy, N.Y.

## Publications

---

D. Horváth, et al., *Experimental Study of Radiative Hyperon Processes following Kaon Capture on the Proton*, J. Phys. B, 160 (1989).

D. Horváth, et al., *Radiative Hyperon Processes following Kaon Capture on Protons*, International Seminar on Intermediate Energy Physics, Moscow, USSR, November 17-30, 1989.

D. Horváth, et al., *Radiative Hyperon Processes Following Kaon Capture on Proton*, to be published in the

proceedings of the Third International Symposium on Pion-Nucleon and Nucleon-Nucleon Physics, Gatchina, USSR, April 1989.

E.K. McIntyre, et al., *Radiative Kaon Capture in Hydrogen, Excited Baryons 1988*, Proceedings ed. G. Adams, N.C. Mukhopadhyay and P. Stoler, World Scientific, 434-438 (1989).

N.P. Hessey, et al., *A Measurement of the Branching Ratio for the  $E^+ \rightarrow p \gamma$  Decay*, Z. Physik, C42, 175 (1989).

D.A. Whitehouse, et al., *Radiative Kaon Capture at Rest on the Proton*, Phys. Rev. Lett. 63, 1352 (1989).

B.L. Roberts, et al., *Radiative Hyperon Processes*, Nuova Cim. 102 A, N. 1, 145 (1989).

B.L. Roberts, *Radiative Hyperon Decay*, Excited Baryons 1988, Proceedings ed. G. Adams, N.C. Mukhopadhyay and P. Stoler, World Scientific, 410-410 (1989).

K.P. Gall, et al., *Radiative Kaon Capture on Deuterium and the  $7n$  Scattering Lengths*, Phys. Rev. C, Rapid Comm., 42, R475 (1990).

A.J. Noble, et al., *A study of the weak radiative decay  $7 \rightarrow 6 n \gamma$* , DPF90 Conference, Houston, January 1990, Bull. Am. Phys. Soc., 35, 1207 (1990).

M.D. Hasinoff, et al., *The reaction  $B p \rightarrow B^0 B^0 n$  near threshold*, DPF90 Conference, Houston, Jan. 1990, Bull. Am. Phys. Soc. 35, 1209 (1990).

B. Bassalleck, et al., *The  $7$  weak radiative decay  $7 \rightarrow 6 n \gamma$  (a status report from Brookhaven experiment 811*, contribution to the 18th INS Int. Symposium on Physics with High-Intensity Hadron Accelerators, Tokyo, March 14-16, 1990.

K.D. Larson, et al., *A report on the measurement of the weak radiative decay  $7 \rightarrow 6 n \gamma$*  (, Proceedings of the International Conference on Particles and Nuclei, MIT, June 1990, abstract V-29.

B.L. Roberts, et al., *Weak Radiative Hyperon Decays*, Int. Symp. on Weak Interactions and Neutrino Physics, Ginosar, Israel, April 1989, Nucl. Phys. B13, 449 (1990).

A.J. Noble, et al., *Measurement of the  $7 \rightarrow 6 n \gamma$  branching ratio*, Phys. Rev. Lett. 69, 410 (1992).

**813** P. D. Barnes (for the E813 collaboration), *Search for the  $H$  particle: its production and weak decay*, LA-UR-92-535-mc (microfiche), Dec., 1991. 14 pp submitted to Intl. Symp. On Hypernuclear and Strange Particle Physics, Simoda, Japan, Dec. 9-12, 1991, published in Nucl. Phys. A547:3c-16c, 1992.

P.H. File, et al., *A New 1-2 GeV/c separated beam for BNL*. Nucl. Inst. and Methods in Physics Research A321 (1992) 48-58.

## Publications

---

V. Sum, et al., *A Time-of-flight array for 1 to 2 GeV/c particles*. Nucl. Inst. and Methods in Physics Research, A326 489-495, North-Holland (1993).

Toru Iijima,  *$H$ -Dibaryon Search in the Reaction  ${}^3d + {}^6\text{He} \rightarrow {}^7\text{He} + n$  at Rest by Measuring the Neutron in Coincidence with the  ${}^3\text{He}$* , Memoirs of the Faculty of Science, Kyoto University, Series A of Physics, Astrophysics, Geophysics and Chemistry, Vol. XXXIX, No. 2, Article 1, 1995.

F. Merrill, *H-Dibaryon Search via  $\pi^-$  Capture on the Deuteron*, UMI-96-05051-m c(microfiche), June 1995, 213 pp, Ph.D. Thesis (Carnegie Mellon U.).

Robert E. Chrien, *H Particle Searches at Brookhaven*. Proc. Int. Conf. Quark Lepton Nuclear Physics, Osaka, Japan, May 20-23, 1997.

**814** B. Bassalleck, et al., *Transverse Energy Distributions in Si-Nucleus Collisions at 10 GeV/nucleon*. Proc. Quark Matter 1987 Conference, Z. Physik, C38 (1988) 45, H.J. Specht, editor.

S.V. Greene, et al., *Search for Strange Matter in Relativistic Heavy Ion Collisions*, Proc. Nato Advanced Study Inst on the Nuclear Equation of State, May 1989, Peniscola, Spain, W. Greiner and H. Stoecker, editors, Nato ASI Series Vol 216B (1989) 117.

M. Fatyga, D. Makowiecki and W.J. Llope, *Fast Monte Carlo Simulation of U/Cu/Si Calorimeters*, Nucl. Inst. Meth. A284 (1989) 323.

J. Barrette, et al., *Electromagnetic Dissociation of  $^{28}\text{Si}$  at  $E_{\text{lab}}/A = 14.6$  GeV by Nucleon Emission*, Phys. Rev. C41 (April 1990) 1512.

J. Barrette, et al., *Energy Flow and Stopping in Relativistic Heavy Ion Collisions at  $E_{\text{lab}}/A = 14.6$  GeV*, Phys. Rev. Lett. 64 (1990) 1219.

J. Barrette, et al. *Search for Strange Quark Matter in High Energy Heavy Ion Collisions*, Phys. Lett. B 252 (1990) 550.

R. Debbe, et al., *A Study of Wire Chambers with Highly Segmented Cathode Pad Read-Out for High Multiplicity Charged Particle Detection*, IEEE Trans. Nucl. Sci. 37 (1990) 82.

R. Bellwied, et al., *Baryon Spectra in the Low Pt Region*, Proc. Workshop on Heavy Ion Physics at the AGS (HIPAGS), March 1990, O. Hansen, Editor, BNL-44911.

B. Shiva Kumar, et al., *Global Observables in Si-Nucleus Collisions at 14.6 GeV/nucleon*, Proc. Workshop on Heavy Ion Physics at the AGS (HIPAGS), March 1990, O. Hansen, editor, BNL-44911.

J.R. Hall, et al., *Charged Particle Multiplicity in Relativistic Heavy Ion Collisions*, Proc. Workshop on Heavy Ion Physics at the AGS (HIPAGS), March 1990, O. Hansen, editor, BNL-44911.

M. Fatyga, et al., *Studying Extremely Peripheral Collisions of Relativistic Heavy Ions*, Proc. Workshop on Heavy Ion Physics at the AGS (HIPAGS), March 1990, O. Hansen, editor, BNL-44911.

J. Fischer, et al., *A Many Particle Tracking Detector with Drift Planes and Segmented Cathode Read-Out*, IEEE Transactions on Nuclear Science 37 (1990) 88.

## Publications

---

W.J. Llope and P. Braun-Munzinger, *Electromagnetic Dissociation of Relativistic Heavy Ions*, Phys. Rev. C (April 1990).

J. Simon-Gillo, et al., *PCal Construction*, Nucl. Instr. Meth. A309 (1991) 427.

W.E. Cleland, et al., *Energy Flow and Nucleon Spectra in Central Collisions of 14.6 GeV/nucleon Si with Al, Cu, and Pb*, Proc. Quarkmatter 90, Menton, Nucl. Phys. A525 (1991) 91c.

- T.K. Hemmick et al., *Production of Exotic Objects*, Proc. Quarkmatter 90, Menton, Nucl. Phys. A525 (1991) 369c.
- M.A. Bloomer, W.A. Love and L. Waters (for the E802, E810, and E814 collaborations), *Recent Results from Relativistic Heavy Ion Experiments at the AGS*, Proc. PANIC XX, MIT, June 1990, Nucl. Phys. A527 (1991) 595c.
- F. Rotondo, et al., *Search for Strange Quark Matter*, Nucl. Phys. B24 (Proc. Suppl.) (1991) 265.
- R. Bellwied, et al., *Forward Baryons in 14.6 GeV/nucleon Heavy Ion Collisions*, Proc. 7th Winter Workshop on Nuclear Dynamics, Key West, Jan. 1991, J. Kapusta and W. Bauer, editors.
- B. Shiva Kumar, et al., *What Can We Learn from Studies of Proton and Antiproton Distributions at AGS Energies?* Proc. 7th Winter Workshop on Nuclear Dynamics, Key West, Jan. 1991, J. Kapusta and W. Bauer, editors.
- J. Stachel, et al., (for the E814 collaboration), *Global Variables and Forward Baryons in 14.6 GeV/nucleon Si-Nucleus Collisions*, Proc. 4th Int. Conf. Nucleus-Nucleus Collisions, Kanazawa, Japan, June 1991, Nucl. Phys. A.
- J. Stachel, et al., (for the E814 collaboration), *Global Variables and Forward Baryons in 14.6 GeV/nucleon Si-Nucleus Collisions*, Proc. Int. Symposium on High Energy Nuclear Collisions and Quark-Gluon Plasma, Kyoto, Japan, June 1991, T. Kunihiro, editor, World Scientific 1992, p. 167.
- J. Barrette et al., *Charged Particle Multiplicity in  $^{28}\text{Si} + \text{Al}, \text{Cu}, \text{Pb}$  Reactions at  $E_{\text{lab}} = 14.6 \text{ GeV/nucleon}$* , Phys. Rev. C46 (1992) 312
- J. Barrette, et al., *Excitation Energy Distribution of Relativistic  $^{28}\text{Si}$  in Electromagnetic Dissociation into  $p + ^{27}\text{Al}$* , Phys. Rev. C45 (1992) 2427.
- P. Braun-Munzinger (for the E814 Collaboration), *Recent Results from Exp. 814 at Brookhaven*, Quark Matter '91 Conference, Gatlinburg, Nov. 1991, Nucl. Phys. A544 (1992) 137c.
- M.S. Muthuswamy (for the E814 collaboration), *Momentum Distributions of Light Mass Fragments in Si-Nucleus Collisions at 14.6 GeV/nucleon*, Quark Matter, '91 Conference, Gatlinburg, Nov. 1991, Nucl. Phys. A544 (1992) 423c.
- S.V. Greene (for the E814 Collaboration), *Antiproton Production in  $^{28}\text{Si}$ -nucleus Interactions*, Quark Matter '91 Conference, Gatlinburg, Nov. 1991, Nucl. Phys. A544 (1992) 599c.
- D. Fox, et al., *Response of the Participant Calorimeter to 1.5-6.8 GeV/c Electrons and Hadrons*, Nucl. Instr. Methods A317 (1992) 474.

## Publications

---

- T.K. Hemmick (for the E814 Collaboration), *Recent Results from Exp. 814*, Proc. XXI Winter Workshop on Nuclear Dynamics, Jackson Hole, WY, Feb. 1992, W. Bauer, editor.
- J. Barrette, et al., *Baryon Distributions in Ultra-Relativistic Nucleus-Nucleus Collisions*, Phys. Rev. Lett. (submitted Oct 1992).

- S. Voloshin (for the E814 Collaboration), *Two-Particle Correlations in the Si+ A Collisions at 14.6 A GeV/c*, HIPAGS 3 Symposium, Boston, January 1993, S. Steadman editor.
- Z. Zhang (for the E814 Collaboration), *Transverse Energy Production in Collisions with 11.4 A GeV/c Au Beam*, HIPAGS 3 Symposium, Boston, Jan. 1993, S. Steadman, editor.
- T. Hemmick (for the E814 Collaboration), *Hadron Production at Low  $p_t$  in E814*, HIPAGS 3 Symposium, Boston, Jan. 1993, S. Steadman, editor.
- J. Dee (for the E814 Collaboration), *Baryon Density and Stopping in E814*, HIPAGS 3 Symposium, Boston, Jan 1993, S. Steadman, editor.
- C. Pruneau (for the E814 Collaboration), *Distribution of Global Variables in Si+ A and Au + A Collisions*, HIPAGS 3 Symposium, Boston, Jan. 1993, S. Steadman, editor.
- N. Xu (for the E814 Collaboration), *Two-Particle Correlations from Si+ Pb Collisions at 14.6 A GeV/c*, HIPAGS 3 Symposium, Boston, Jan. 1993, S. Steadman, editor.
- S. Kumar (for the E814 Collaboration), *Antiproton Production in Si+ A Collisions at 14.6 A GeV/c*, HIPAGS 3 Symposium, Boston, Jan. 1993, S. Steadman, editor.
- T. K. Hemmick (for the E814 Collaboration), *Hadron Production and Correlations from E814*, Proc. XXII Winter Workshop on Nuclear Dynamics, Key West, Florida, Feb. 1993, B. Back, editor.
- J. Barrette (for the E814 Collaboration), *Transverse Energy Production with Si and Au Beams at AGS Energy: Towards Hot and Dense Hadronic Matter*, Proc. Quarkmatter '93, Nucl. Phys. A566 (1993) 411c.
- J. Stachel (for the E814 Collaboration), *Particle spectra and Correlations from Experiment 814*, Proc. Quarkmatter '93, Nucl. Phys. A566 (1994) 183c.
- T. K. Hemmick (for the E814 Collaboration), *Low  $p_t$  Pion Enhancement in  $^{28}\text{Si} + \text{Pb}$  Collisions at 14.5 A GeV/c*, Proc. Quarkmatter '93, Nucl. Phys. A566 (1994) 435c.
- M. Rosati (for the E814 Collaboration), *Particle Production in  $p + \text{A}$  Collisions at 14.6 GeV/c*, Proc. Quarkmatter '93, Nucl. Phys. A566 (1994) 597c.
- N. Xu (for the E814 Collaboration), *Pion Interferometry in  $^{28}\text{Si} + \text{Pb}$  Central Collisions*, Proc. Quarkmatter '93, Nucl. Phys. A566 (1994) 585c.
- J. Barrette, et al., (for the E814 collaboration), *Two Charged Particle and Transverse Energy Correlations in Si + Pb Collisions at 14.6 A GeV/c*, Phys. Rev. C49 (1994) 1669.

## Publications

---

- Z. Zhang, P. Braun-Munzinger, W. Cleland, G. David, D. Lissauer, *Response Matrix Approach to the Analysis of Calorimetry Data*, Nucl. Instr. Meth. A 343 (1994) 610.
- P. Braun-Munzinger, (for the E814 Collaboration), *Compression, Expansion and Freeze-out in "Hot and Dense Nuclear Matter"*, Plenum Press, New York 1994, p. 419, W. Greiner, H. Stöcker, and A. Gallmann, eds.
- G. David, et al., *Prototype Tests of a High Resolution Electromagnetic Calorimeter Using Undoped CsI Crystal*,



Nucl. Inst. Meth. Phys. Res. A348 (1994) 87.

J. Barrette, et al., (for the E814 Collaboration), *Production of Light Nuclei in Relativistic Heavy Ion Collisions*, Phys. Rev. C50 (1994) 1077.

J. P. Wessels and Y. C. Zhang, (for the E877 Collaboration), *Is there Flow at the AGS?*, Proc. 10th Winter Workshop on Nuclear Dynamics, Snowbird, Utah, Jan. 1994, W. Bauer, editor.

N. Xu, (for the E814 Collaboration), *Two-Pion Interferometry-Towards Equilibrium at the AGS*, Proc. 10th Winter Workshop on Nuclear Dynamics, Snowbird, Utah, Jan. 1994, W. Bauer, editor.

J. Barrette, et al., (for the E814 collaboration), *Centrality Dependence of Longitudinal and Transverse Baryon Distributions in Ultrarelativistic Nuclear Collisions*, Phys. Rev. C50 (1994) 3047.

J. Barrette, et al., (for the E814 collaboration), *Evidence for Expansion of a Hot Fireball from Two-Pion Correlations for Si + Pb Collisions at AGS Energy*, Phys. Lett. B333 (1994) 33.

J. Barrette, et al., (for the E814 collaboration), *Electromagnetic Dissociation of Relativistic  $^{28}\text{Si}$* , Phys. Rev. C51 (1995) 865.

J. Barrette, et al., (for the E814 collaboration), *Measurement of Pion Enhancement at Low Transverse Momentum and of the  $\rho$  Resonance Abundance in Si-Nucleus Collisions at the AGS*, Phys. Lett. B351 (1995) 35.

**815** K. B. Bhalla, et al., *Particle Densities and Nuclear Breakup in  $^{16}\text{O}$  - Emulsion Interactions*, Proc. Int. Europhysics Conf. On High Energy Physics, Uppsala, Sweden, June 25-July 1, 1987, Vol. I, pp. 155. (Petit-Lancy, Switzerland: Eur. Phys. Soc., 1987).

H. H. Heckman, et al., *Nuclear Breakup and Particle Densities in 200 A GeV- $^{16}\text{O}$  Interactions with Emulsion Nuclei*, Proc. of XVIII Int. Symp. on Multiparticle Dynamics, Tashkent, USSR, Sept 8-12, 1987, p. 411-420. (World Scientific, Singapore, 1988, Eds.: I. Remin and K. Gulamov.)

E. Monnard, et al., *Pseudorapidity Densities in Central  $^{16}\text{O}$  Interaction at 200 A GeV*, Proc. of the Workshop held at Moscow, USSR, August 1987, during the 20th Int. Cosmic Ray Conf., Moscow, Lebedev, 1988, p. 4-10.

M.I. Adamovich, et al., *Multiplicities and Rapidity in 200 A GeV $^{16}\text{O}$  Interactions with Emulsion Nuclei*, Phys. Rev. Lett. B201, 397 (1988).

S. Garpman, et al., *A Computer Based Coordinate Measuring Station for Nuclear Emulsion Chambers*, Nucl. Instr. Meth. A269, 134 (1988).

## Publications

---

S. Lokanathan, et al., *The EMU-01 Experiment: A Status Report*, Proc. Int. Conf. on Physics and Astrophysics of Quark Gluon Plasma, Bombay, India, February 8-12, 1988, p. 514-522. (World Scientific, Singapore, 1989, Eds.: B. Sinha and S. Raha.)

R. J. Wilkes, et al., *Pseudorapidity Distributions and Correlations in Central  $^{16}\text{O}$  Interactions at 200 A GeV*, Proc. 3rd Conf. on the Intersections between Particle and Nuclear Physics, Rockport, ME, May 14-19 1988. AIP Conf. Proc. (USA) 176 (1988) 1047. G. Bunce, editor.

- M.I. Tretyakova, et al., *Central Interactions of  $^{16}\text{O}$  Nuclei with Heavy Nuclei of Photoemulsion at 200 GeV/Nucleon*, P. N. Lebedev Physical Institute Reprint 244 (1988). Proc. IX Int. Seminar on High Energy Physics Problems-Relativistic Nuclear Physics and Quantum Chromodynamics, Dubna, June 1988.
- E. Friedlander, et al., *A Search for Non-Statistical Fluctuations and Structures in the Rapidity Density Distribution of  $^{16}\text{O} + \text{Ag}(\text{Br})$  and  $^{32}\text{S} + \text{Au}$  Interactions at 60 and 200 A GeV*. Proc. Hadronic Matter in Collision, Tucson, Arizona, October 6-12, 1988, p. 210-221. (World Scientific, Singapore, 1989, Eds.: B.P. Carruthers and J. Rafelski.)
- E. Stenlund, et al., *A Search for Non-Statistical Particle Density Fluctuations in  $^{16}\text{O} + \text{Ag}(\text{Br})$  and  $^{32}\text{S} + \text{Au}$  Interactions at 200 A GeV*, Proc. 7th Int. Conf. on Ultra-Relativistic Nucleus-Nucleus Collisions - Quark Matter 1988, Lennox, Massachusetts, September 26-20, 1988, Nucl. Phys. A 498 (1989) 541c.
- M.I. Adamovich, et al., *Scaling Properties of Charged Particle Multiplicity Distributions in Oxygen Induced Emulsion Interactions at 14.6, 60 and 200 A GeV*, Phys. Lett. B, 223, 262 (1989).
- M.I. Adamovich, et al., *Limiting Fragmentation in Oxygen-Induced Emulsion Interactions at 14.6, 60 and 200 GeV/nucleon*, Phys. Rev. Lett. 62, 2801 (1989).
- M.I. Adamovich, et al., *Production of helium ( $Z=2$ ) Projectile Fragments in  $^{16}\text{O}$ -Emulsion Interactions from  $E/A=2$  to 200 GeV*, Phys. Rev. C 40, 66 (1989).
- M.I. Adamovich, et al., *A Study of Recoil Protons in Ultra-Relativistic Nucleus-Nucleus Collisions*, Phys. Lett. B 230, 175 (1989).
- M.I. Adamovich, et al., *Charged Particle Spectra in Oxygen-Induced Reactions at 14.6 and 60 GeV/Nucleon* High Energy Physics and Nuclear Physics in China 13 (1989) 341; 13 (1989) 865. [English and Chinese.]
- M.I. Adamovich, et al., *Rapidity Densities and their Fluctuations in Central 200A GeV  $^{32}\text{S}$  Interactions with Au and Ag, Br. Nuclei*, Phys. Lett. 227B, 285 (1989).
- M.I. Adamovich, et al., *On the Multiplicity Fluctuations in Relativistic Heavy Ion Collisions*, Lund University Preparing LUIP 8912 (1989). Submitted to Phys. Lett. B.
- S. Persson, *Measurement and Three-Dimensional Reconstruction of Particle Tracks in Emulsion Chambers*, Comp. Phys. Comm. 55, 103 (1989).
- E. Stenlund et al., *A Search for Non-Statistical Particle Density Fluctuations in  $^{16}\text{O} + \text{Ag}(\text{Br})$  and  $^{32}\text{S} + \text{Au}$  Interactions at 200 A GeV*, Nucl. Phys. A498, 541c (1989).

## Publications

- 
- E. Ganssauge et al., *A Track Reconstruction Program (TRP) for Evaluation of Nucleus-Nucleus Collisions in Nuclear Track Emulsion Chambers*, Comp. Phys. Comm. 55 (1989) 233.
- M. I. Adamovich et al., *On the Energy and Mass Dependence of the Multiplicity in Relativistic Heavy Ion Interactions*, Modern Physics Letters A 5, 169 (1990).
- I. Otterlund, et al., *Stochastic Emission and Non-Statistical Fluctuations in Relativistic Heavy-Ion Interactions*, Proc. X Int. Seminar on High Energy Physics Problems-Relativistic Nuclear Physics and Quantum

Chromodynamics, Dubna, Sept 1990.

E. Gansauge, et al., *Contribution of the EMU01 Collaboration to the research for a Quark Gluon Plasma (QGP)*, Proc. XV Int. Conf. on Particle Tracks in Solids, Marburg, FRG, September 3-7, 1990.

M. I. Tretyakova, et al., *Central Interactions  $S + AgBr$  at 200 A GeV*, Proc. X Int. Seminar on High Energy Physics Problems-Relativistic Nuclear Physics and Quantum Chromodynamics, Dubna, Sept 1990, p. 412-419.

I. Otterlund, et al., *Limiting Fragmentation, Scaling and Substructural Dependence of Multiparticle Production in High-Energy Heavy-Ion Interactions*, Proc. 6th Nordic Meeting on Nuclear Physics. Kopervik, Norway, August 1989, Physica Scripta (1990) 168.

M. I. Adamovich, et al., *Target Nucleus Fragmentation in  $^{16}O + (Ag, Br)$  Interactions at 200 A GeV*, Phys. Lett. 234B, 180 (1990).

M. I. Adamovich, et al., *Scaled Factorial Moment Analysis of 200 A GeV Sulphur + Gold Interactions*, University of Washington Preprint UW SEA PUB 90-4 (Seattle, 1990), Phys. Rev. Lett. 65 (1990) 412.

M. I. Adamovich, et al., *On the Multiplicity Fluctuations in Relativistic Heavy-Ion Collisions*, Phys. Lett. 242B (1990) 512.

E. Stenlund, et al., *Recent Results from EMU01*, Proc. Workshop on Heavy Ion Physics at the AGS, HIPAGS'90, Brookhaven National Laboratory, Upton, NY, March 5-7, 1990, pp. 70, BNL-44911. (Ed.: O. Hansen.)

Liu Lianshou, et al., *Energy, Target, Projectile and Multiplicity Dependence of Intermittency Behavior in High-Energy  $O(Si,S)$ -Emulsion Interactions*. Proc. XX Int. Symp. on Multiparticle Dynamics, Dortmund, FRG, September 13-18, 1990.

S. Garpman, et al., *Rapidity Fluctuations, Cluster Partitions and Intermittency in Relativistic Heavy Ion Collisions*, Nucl. Phys. A525 (1991) 551c.

I. Otterlund, et al., *Extrapolations Based on EMU01-data from Oxygen, Silicon and Sulphur Violent Interactions at Medium and High Energies*, Lund University Preprint LUIP9105, Proc. Int. Symp. on High Energy Nuclear Collisions and Quark Gluon Plasma, Kyoto, Japan, June 6-8, 1991.

E. Stenlund, et al., *Recent EMU01-Results on Fluctuations and Intermittency*, Lund University Preprint LUIP 9106, Proc. Ringberg Workshop on Multiparticle Production, Fluctuations and Fractal Structure, Ringberg Castle, Germany, June 25-28, 1991, p. 171-183. (World Scientific, Singapore, 1992, Eds.: R. C. Hwa, W. Ochs and N. Schmitz.)

## Publications

---

M. M. Chernyavsky, et al., *A Direct Analysis of Intermittency-Generating Cascading in High Energy Nucleus-Nucleus Collisions*, Proc. XXI Int. Symp. on Multiparticle Dynamics, Wuhan, China, Sept 23-27, 1991. p. 442-445. (World Scientific, Singapore, 1992. Eds.: Wu Yuanfang and Liu Lianshou.)

M. I. Adamovich, et al., *Energy, Target, Projectile and Multiplicity Dependence of Intermittency Behavior in High-Energy  $O(Si,S)$ -Emulsion Interactions*, Z. Phys. C 49 (1991) 395.

M. I. Adamovich, et al., *Stochastic Emission of Particles in Ultra-Relativistic Heavy-Ion Collisions*, Modern Physics Letters A 6 (1991) 469.

- M. I. Adamovich, et al., *Slow, Target Associated Particles Produced in Ultrarelativistic Heavy-Ion Interactions*, Phys. Lett. 262B (1991) 369.
- I. Otterlund, et al., *Multiplicity Fluctuations in High-Energy Heavy-Ion Interactions Observed in High-Angular Resolution Tracking Detectors*, Proc. Santa Fe Workshop on Intermittency in High-Energy Collisions. Santa Fe, New Mexico, March 18-21, 1990, p. 126-44. (World Scientific, Singapore, 1991, Eds.: F. Cooper, R. C. Hwa, I. Sarcevic.)
- J. Wilkes, et al., *Scaled Factorial Moment Analysis of 200 A GeV S+ Au Interactions*. Proc. Santa Fe Workshop on Intermittency in High-Energy Collisions. Santa Fe, New Mexico, March 18-21, 1990, p. 145-157. (World Scientific, Singapore, 1991, Eds.: F. Cooper, R. C. Hwa, I. Sarcevic.)
- M. I. Adamovich, et al., *The Systematical Investigation of Intermittency in High Energy Heavy Ion Collisions*, High Energy Physics and Nuclear Physics in China 15 (1991) 131. (Chinese)
- E. Stenlund, et al., *Non-Statistical Fluctuations in Relativistic Heavy-Ion Collisions*. Proc. Int. Workshop on Correlations and Multiparticle Production (CAMP) (LESIP IV), Marburg, F. R. Germany, May 14-16, 1990, p. 337-344. (World Scientific, Singapore, 1991, Eds.: M. Plümer, S. Raha, and R. M. Weiner.)
- M. I. Adamovich, et al., *On the Systematic Behavior of the Intermittency-Indices in Nuclear Interactions*, Phys. Lett. 263B (1991) 539.
- R. J. Wilkes, et al., *Review of Recent Results on Particle Production from EMU01*, Nucl. Phys. A544 (1992) 153c.
- E. Stenlund, et al., *Survey of Recent EMU01-Results from CERN/SPS and BNL/AGS*. Proc. Joint Int. Lepton-Photon Symp. & Europhysics Conf. on High Energy Physics, Geneva, Switzerland, July 25-August 1, 1991, Vol. 1, p. 478-481. (World Scientific, Singapore, 1992, Eds.: S. Hegarty, K. Potter and E. Quercigh).
- M. I. Adamovich, et al., *A Systematical Investigation of the Energy Independent Behaviour in the Fragmentation Regions for  $^{16}\text{O} + \text{Em}$  Interactions from 3.7 to 200 A GeV*, Z. Phys. C 55 (1992) 235.
- I. Adamovich, et al., *On Intermittency in Heavy Ion Collisions and the Importance of (-Conversion in a Multi-Dimensional Intermittency Analysis*, Nucl. Phys. B388 (1992) 3.
- M. I. Adamovich, et al., *Limiting Fragmentation Behaviour of Correlation and Fluctuation of Particles Produced in High Energy Oxygen-Nucleus Induced Interactions*, High Energy Physics and Nuclear Physics in China 16 (1992) 991.

## Publications

---

- M. I. Adamovich, et al., *Local Particle Densities and Global Multiplicities in Central Heavy Ion Interactions at 3.7, 14.6, 60 and 200 A GeV*, Z. Phys. C56 (1992) 509.
- H. Q. Wang, et al., *Limiting Fragmentation of Two-Particle Correlation and Dynamical Fluctuation in O-Em Interactions*, Proc. XXI Int. Symp. on Multiparticle Dynamics, Wuhan, China, Sept. 23-27, 1991. p. 436-441. (World Scientific, Singapore, 1992, Eds.: Wu Yuanfang and Liu Lianshou)
- M. I. Adamovich, et al., *Rapidity Density Distributions in  $^{16}\text{O}$ ,  $^{28}\text{Si}$ ,  $^{32}\text{S}$ ,  $^{197}\text{Au}$  and  $^{208}\text{Pb}$  Induced Heavy Ion Interactions at 4 - 200 A GeV*, Phys. Rev. Lett. 69 (1992) 745.

- M. I. Adamovich, et al., *Studies of Angular Distribution of Helium Projectile Fragments in Interactions of 200 A GeV<sup>32</sup>S Ions with Emulsion Nuclei*, Modern Physics Letters A 8 (1993) 21.
- M. I. Adamovich, et al., *Systematic Investigation of Scaled Factorial Cumulant Moments for Nucleus-Nucleus Interactions*, Phys. Rev. D 47 (1993) 3726.
- M. I. Adamovich, et al., *On the Jet-Like and Ring-Like Substructure in Distributions of Produced Particles in Central Heavy-Ion Collisions at Ultra-Relativistic Energies*, Journal of Physics G - Nuclear and Particle Physics 19 (1993) 2035.
- M. I. Adamovich, et al., *Rapidity Density Distributions and their Fluctuations in Violent Au-Induced Interactions at 11.6 A GeV/c*, Phys. Lett. B 322 (1994) 166.
- J. Nystrand, et al., *Rapidity Density Distributions in Au+ Au and Au Ag Interactions at 11.6 A GeV/c*, Nucl. Phys. A566 (1994) 419c.
- M. I. Adamovich, et al., *Relative Information Entropy of Particle Production in High Energy Induced Nuclear Reactions*, High Energy Physics and Nuclear Physics in China 18 (1994) 61; 18 (1994) 291. (English and Chinese.)
- M. I. Adamovich, et al., *Local Characters of Final State Multiplicity Spectra in High Energy Heavy-Ion Central Collisions*, High Energy Physics and Nuclear Physics in China 18 (1994) 884. (Chinese.)
- M. I. Adamovich, et al., *Helium Production in 10.7 A GeV Au Induced Nucleus-Nucleus Collisions*, Phys. Lett. B338 (1994) 397.
- M. I. Adamovich, et al., *On the Production of Slow Particles in High Energy Heavy Ion Collisions*, Z. Phys. C 65 (1995) 421.
- M. I. Adamovich, et al., *<sup>28</sup>Si (<sup>28</sup>S) Fragmentation at 3.7 A, 14.6 A and 200 A GeV*, Z. Phys. A 351 (1995) 311.
- M. I. Adamovich, et al., *Charged Particle Multiplicity and Pseudorapidity Density Distributions in <sup>16</sup>O-, <sup>28</sup>Si- and <sup>197</sup>Au-Induced Nuclear Interactions at 14.6 and 11.6 A GeV/c*, submitted to Nucl. Phys. A.
- M. I. Adamovich, et al., *Charged Particle Density Distributions in Au Induced Interactions with Emulsion Nuclei at 10.7 A GeV*, accepted for publication in Phys. Lett. B.

## Publications

---

- 816** P. Astier, *Search for neutrino oscillations*, Proceedings of BNL Neutrino Workshop, M. Murtagh, ed. (1987).
- P. Astier, et al., *Search for Neutrino Oscillations*. Phys. Lett. 220B (1989), 646.
- 817** B.E. Bonner, et al., *Spin transfer in hyperon production*, Phys. Rev. Lett. 58, 447 (1987).
- B.E. Bonner, et al., *Spin-parameter measurements in  $\Lambda$  and  $K_s$  production*, Phys. Rev. D 38, 729 (1988).
- B.E. Bonner, et al., *Spin-Parameter Measurements in Inclusive  $E^0$  Production*, Phys. Rev. Lett. 62, 1591 (1989).

- B.E. Bonner, et al., *Analyzing power of inclusive production of  $B^+ B^-$  and  $K_S^0$  by polarized protons at 13.3 and 185 GeV/c*, Phys. Rev. D, 41, 13 (1990).
- 820** K. Johnston, et al., *Search for A Strangeness-1 dibaryon below the sigma N threshold*, 1992.
- 821** V. Hughes, *The Muon Anomalous Magnetic Moment*, Physica Scripta, T22, 111 (1988).
- L. M. Barkov, et al., *The Anomalous Magnetic Moment of the Muon*, Proc. 9th International Symposium on High Energy Spin Physics (1990).
- B. L. Roberts, *The New Muon  $g-2$  Experiment at BNL*, Proc. International Symposium on the Future of Muon Physics (1991).
- V. W. Hughes, *The Anomalous Magnetic Moment of the Muon*, Proc. Second International Symposium on Particles, Strings and Cosmology, 868, Boston, MA, 25-30 March 1991. World Scientific, Pran Nath and Stephen Reucroft, eds.
- G. T. Danby, W. Meng, W. B. Sampson, K. Woodle, *Magnetic Flux Shielding for the Precision Muon  $g-2$  Storage Ring Superconducting Inflector*. Presented to 13th International Conference on Magnet Technology, Victoria, B. C. Canada (1993).
- L. X. Ja, L. J. Addessi, J. R. Cullen, Jr., A. J. Esper, M. A. Green, R. E. Meier, C. Pai, L. P. Snydstrup, T. N. Tallero, *Cryogenics for the Muon  $g-2$  Superconducting Magnet System*. Submitted to 15th International Cryogenic Engineering Conference, Genoa, Italy, (1994).
- L. X. Ja, L. J. Addessi, J. R. Cullen, Jr., A. J. Esper, R. E. Meier, C. Pai, L. P. Snydstrup, *Design Parameters for Gas-Cooled Electrical Leads of the  $g-2$  Magnets*. Presented at 15th International Cryogenic Engineering Conference, Genova, Italy (1994).
- F. Krienen, G. T. Danby, W. Meng, C. Pai, W. B. Sampson, S. A. Woodle, M. A. Green, A. Yamamoto, H. Hirabayashi. *The Superconducting Inflector Dipole for the Muon  $g-2$  Storage Ring*. Submitted to 1994 Applied Superconductivity Conference, Boston, MA (1994).
- Michael A. Green and W. Meng. *Magnetization Effects from the  $g-2$  Inflector Magnet Superconductor*. Submitted to 1994 Applied Superconductivity Conf., Boston, Massachusetts. (1994).
- H. C. Hseuh, L. Snydstrup, M. Mapes. *Beam Vacuum System of Brookhaven's Muon Storage Ring*. Presented at 42nd National AVS Symposium, Minneapolis, MN, October 16-20, 1995 (BNL-61510).

## Publications

- 
- B. L. Roberts, et al., *Status of the New Muon ( $g-2$ ) Experiment* Proceedings of the Int. Conf. on High Energy Physics, Warsaw 1996.
- 825** J.B. Cumming, Y.Y. Chu, and P.E. Haustein. *Momentum transfer in the reactions of 13.6-GeV/nucleon  $^{16}O$  with copper*. Phys. Rev. C, 46, 2042-2046 (1992).
- 828** R.E. Chrien, et al. *Search for bound states of the  $O$ -meson in light nuclei*. Phys. Rev. Lett. 60, 2595-8, 1988.
- P.H. File, *A search for bound states of the  $O$ -meson in light nuclei*. Proc. 3rd Conf. on the Intersections Between Particle and Nuclear Physics, May 14-19, 1988, Rockport, ME. G.M. Bunce, Editor, AIP Conference Proceedings 176, 719-724.

- 834** A.S. Carroll, et al. *Nuclear Transparency to Large-Angle pp Elastic Scattering*, Phys. Rev. Lett., 61, 1698 (1988).
- 835** J. Alster, in Workshop on Nuclear Structure with Medium Energy Probes, Santa Fe, NM, 1988. A G S Experiment 835 Collaboration, *Kaon-Nucleus Total Cross Sections*, PANIC X I I International Conf. on Particles and Nuclei, Cambridge, MA. June 25-29, 1990.
- Y. Mardor, et al., *K<sup>+</sup> total cross sections as a test for nucleon "swelling."* Phys. Rev. Lett. 65, 2110-13 (1990).
- Y. Mardor, *K<sup>+</sup> Total Cross Sections and Swelling in Nuclei*. Thesis submitted toward the M.Sc. degree in at Tel-Aviv University (1990).
- J. Alster (representing collaboration). *K<sup>+</sup>-nucleus total cross section experiment and nuclear medium effects*. Nucl. Phys. A547, 321c-30c (1992).
- R.A. Krauss et al., *K<sup>+</sup> total cross sections on <sup>12</sup>C and medium effects in nuclei*, Phys. Rev. C 46, 655, 1992.
- R. Sawafta (Exp. 835 Collaboration). *The K<sup>+</sup> meson as a probe of the nuclear medium*. Invited talk. Fourth Conference on the Intersections between Particle and Nuclear Physics, Tucson, Arizona, May 24-29, 1991, W.T.H. van Oers, Editor, AIP Conf. Series 243, 582-7 (1992).
- R.E. Chrien, *The K<sup>+</sup> as a probe of nuclear medium effects*. Invited talk. Workshop on Strangeness in Nuclei, Krakow, Poland, May 5-7, 1992. To appear in Nukleonika.
- R. Sawafta, et al., *The influence of the nuclear medium on K<sup>+</sup> total cross sections*. Phys. Rev. Lett. B307, 293 (1993).
- 836** R. W. Stotzer, et al., *Search for the H-Dibaryon in <sup>3</sup>He (K, K<sup>+</sup>)Hn*, Phys. Rev. Letts. 78, 3636 (1997).
- 838** C. White, et al., Phys. Rev. D 49, 58 (1994). *Comparison of 20 Exclusive Reactions at Large t*
- 840** Y. Semertzidis, et al., *An Experiment to Produce Light Pseudoscalars and QED Vacuum Polarization*. Proceedings of the Workshop on Cosmic Axions (BNL, 1989), C. Jones and A.C. Melissinos, eds., World

Scientific, P. 137 (1990).

Y. Semertzidis, et al., *Limits on the Production of Light Scalar and Pseudoscalar Particles*, Phys. Rev. Lett. 64, 2988 (1990).

## Publications

---

Y. K. Semertzidis, *Coherent Production of Light Pseudoscalars (Axions) Inside a Magnet Field with a Polarized Laser Beam*,; University of Rochester, Department of Physics and Astronomy, Rochester, NY. UR-1141, ER-13065-603. January 17, 1991.

R. Cameron, et al., *Measurement of the Magnetic Birefringence of Neon Gas*, J. Opt. Soc. Am B8, 520 (1991).

R. Cameron, et al., *A Search for the Coherent Production of Axions in the millieV Range*, *Particles and Fields 1991, 1002 (1991)*.

R. Cameron, et al. *First measurement of the Magnetic Birefringence of Helium Gas*, Phys. Letts. A157, (1991).

D.M. Lazarus, et al., *A Search for Solar Axions*, Phys. Rev. Lett. 69, 2333 (1992).

G. Ruoso, et al., *Limits on Light Scalar and Pseudoscalar Particles from a Photon Regeneration Experiment*, University of Rochester, Department of Physics and Astronomy, Rochester, NY. UR-1248, ER-13065-697, January 1992.

G. Ruoso, R. Cameron, A.C. Melissinos, Y. Semertzidis, H.J. Halama, D.M. Lazarus, A.G. Prodel, F. Nezirick, C. Risso, E. Zavattini, *Search for Photon Regeneration in a Magnetic Field*, Zeits. fur Phys. C56, 505 (1992).

**845** K.E. Ohl, et al., *A Measurement of the Branching Ratio and Form Factor for  $K_L \rightarrow 6e^+e^-$* , Phys. Rev. Lett., 65, 1407 (1990).

K.E. Ohl, et al., *Improved Experimental Limit on  $K_L^0 \rightarrow 6B^0e^+e^-$* , Phys. Rev. Lett. 23, 2755 (1990).

K.E. Ohl, et al., *Improved Experimental Limit on  $K_L \rightarrow 6B^0e^+e^-$* , Phys. Rev. Lett. 64, 2755 (1990).

W.M. Morse, et al., *Results from AGS E845:  $K_L^0 \rightarrow 6B^0e^+e^-$ ,  $e^+e^-$ ,  $e^+e^-e^+e^-$* , "Proc. of the Conference on the Intersections Between Particle and Nuclear Physics, Tucson, AZ, May 24-29, 1991, AIP Conf. Proc. 243.

W.M. Morse, et al., *Search for the Decay  $K_L^0 \rightarrow 6B^0e^+e^-$* , Nuc. Phys. A527 (1991) 717c-720c.

W.M. Morse, et al., *Observation of the decay mode  $K_L^0 \rightarrow 6(ee)$* , Phys. Rev. D, 45, 36 (1992).

**847** G. Singh, A.Z.M. Ismail and P.L. Jain, *Characteristics of helium fragments produced in  $^{28}\text{Si}$  emulsion and interactions at 14.5 GeV*, Phys. Rev. C, 43, 2417 (1991).

P.L. Jain, G. Singh, and K. Sengupta, *Rapid Communications*, Phys. Rev. C., Vol. 43, No. 5 (1991).

P.L. Jain, G. Singh, and K. Sengupta, *Comparison of Nucleus-Nucleus Interactions at 14.5 - 200A GeV with a Multistring Model*, Phys. Rev. C43, R2027 (1991).

P.L. Jain and G. Singh, *One- and Two-dimensional Analysis of Intermittency in Ultra-relativistic Nucleus-Nucleus Interactions*, Phys. Rev. C44, 854 (1991).



- 
- P.L. Jain, G. Singh, and K. Sengupta, *Intranuclear Cascading at Ultrahigh Energy in Heavy-ion Interactions*, *Z. Phys.* **C52**, 465 (1991).
- P.L. Jain and G. Singh, *Investigation of Intermittency in  $^{28}\text{Si}$ -nucleus Collisions at 14.5A GeV*, *Mod. Phys. Lett.* **A7**, 93 (1992).
- P.L. Jain and G. Singh, *Intermittency in Relativistic Heavy-ion Collisions*, *Z. Phys.* **C53**, 355 (1992).
- 850** J.A. Appel, J. Botts, G. Bunce, G. Farrar, S. Forde. Color Transparency Study Group. BNL-45319.
- A. Carroll and T. Londergan, *Hadron dynamics - working group summary*, future directions in particle and nuclear particle physics at multi-GeV hadron beam facilities (1993).
- J. Y. Wu, et al., *the EVA trigger: transverse momentum selection in a solenoid*, *NIM* **A349** (1994).
- T. Mardor, et al., *Measurement of quasi-elastic  $^{12}\text{C}$  ( $p$ ,  $2p$ ) scattering at high momentum transfer*, submitted to *Phys. Rev. Lett* (1997).
- J. Aclander, et al., *A direct measurement of short range NN correlations in nuclei via the reactive  $^{12}\text{C}$  ( $p$ ,  $2p$  +  $h$ )*, submitted to *Phys. Rev. Lett* (1997).
- A. S. Carroll, et al., *Measurement of color transparency by C ( $p$ ,  $2p$ ) reaction at large momentum transfer*, HADRON97 conf., BNL, Ed. S-U Chung (1997).
- J. Aclander, et al., *Short range NN correlations: a direct measurement*, HADRON97 conf., BNL, Ed. S-U Chung (1997).
- T. Mardor, et al., *High  $p_t$  quasi-exclusive scattering with resonance production*, 6th conf. On Intersection of Particle and Nuclear Physics (1997).
- T. Mardor, et al., *Quasi-elastic hadronic scattering at high momentum transfer*, 6th conf., on Intersections of Particle and Nuclear Physics (1997).
- 851** A. Deshpande, et al., *Determination of the Branching Ratio of the Decay  $B^0 \rightarrow 6 e^+ e^-$* , *DFT 1993*, The Fermilab Meeting.
- 852** A. Dzierba and S. Tiege for the E852 Collaboration, *First Results from the E852 Tests of a 320-Element Lead-Glass Calorimeter*. AGS Users Newsletter June 24, 1992.
- B.B. Brabson, et al., *A study of two prototype lead glass electromagnetic calorimeters*. *Nucl. Instr. & Meth.* **A332**, 419-443 (1993).
- A.R. Dzierba, *Meson Spectroscopy with B and K Beams*. To appear in the Proceedings of the Workshop on Future Directions in Particle and Nuclear Physics at Multi-GeV Facilities, Brookhaven National Laboratory, March 4-6, 1993.
- S. Y. Chung, *Search for exotic mesons, invited talk at Workshop on Hadron Physics at  $e^+ e^-$  Colliders*, IHEP, Beijing, China, October 1994.

## Publications

---

- Z. Bar-Yam, et al., *A cylindrical drift chamber of novel design*. Nucl. Instrum. & Methods A312, 398-410 (1995).
- Z. Bar-Yam, et al., *A scintillation detector of unique geometry*. Nuclear Instrum. & Methods, A357, 95-102 (1995).
- S. U. Chung, *Summary of Hadron95*. Summary Talk given at the Sixth International Conference on Hadron Spectroscopy, Manchester, England, July 9-14, 1995. (BNL-QGS-95-91)
- S. Teige, et al., *The Brookhaven National Laboratory E852 lead glass calorimeter system*, Proc. of 5th Intl. Conf. on Calorimetry in HEP, eds. H.A. Gordon and D. Rueger, 161-166 (1995).
- J. Dowd, *Properties of the reaction  $Bp \rightarrow p OB \bar{B} B$  at 18 GeV/c*, Proc. of the 5th Intern. Conf. on Hadron Spectroscopy, Manchester, England, eds. M. C. Birse, G. D. Lafferty, and J. A. McGovern, World Scientific, Singapore, (1996).
- T. Adams, et al., *Resonance production in the reaction  $B\bar{p} \rightarrow n \bar{B} B^0 B^0$* , Proc. of the 5th Intl. Conf. on Hadron Spectroscopy, Manchester, England, eds. M. C. Birse, G. D. Lafferty, and J. A. McGovern, World Scientific, Singapore, 491-493 (1996).
- T. Adams, et al., *Design and performance of a cesium iodide detector*. Nucl. Instrum. & Meth. A368, pp. 617-627 (1996).
- B. B. Brabson, et al., *Study of the  $B^0 B^0$  system in  $B$ - $p$  interactions at 18 GeV/c*. Proc. of the 5th Intern. Conf. on Hadron Spectroscopy, Manchester, England, eds. M. C. Birse, G. D. Lafferty, and J. A. McGovern, World Scientific, Singapore, 494-496 (1996).
- N. Cason, et al., *Study of the  $OB$ ,  $OO$ , and  $OB$  systems in  $B$ - $p$  interactions at 18 GeV/c*. Proc. of the 5th Intern. Conf. on Hadron Spectroscopy, Manchester, England, eds. M. C. Birse, G. D. Lafferty, and J. A. McGovern, World Scientific, Singapore, 55-62 (1996).
- N. Cason, et al., *Study of the  $OB^{\bar{}}$ ,  $OB^0$  and  $B^{\bar{}}p$  interactions at 28 GeV/c*. Proc. HADRON 95 Conf., Manchester, England, June 1995, M. C. Birse, G. D. Lafferty, and J. A. McGovern, Editors, World Scientific, Singapore, pp. 55-61 (1996).
- N. Cason, et al., *Study of  $B^{\bar{}}B^{\bar{}}B^{\bar{}}$  interactions at 18 GeV/c*. (Presented by Dennis Weygand for the E852 collaboration.) Proc. HADRON 95 Conf., Manchester, England, June 1995, M. C. Birse, G. D. Lafferty, and J. A. McGovern, Editors, World Scientific, Singapore, pp. 241-247 (1996).
- N. Cason, et al., *Observation of  $f_1(1285)B$  and  $OM(958)B$  in the reaction  $B^{\bar{}}p \rightarrow p OB^{\bar{}}B^{\bar{}}B^{\bar{}}$  at 18 GeV/c*. Presented by J. P. Dowd for the E852 collaboration.) Proc. HADRON 95 Conf., Manchester, England, June 1995, M. C. Birse, G. D. Lafferty, and J. A. McGovern, Editors, World Scientific, Singapore, pp. 497-499 (1996).
- J. M. LoSecco, et al., *Search for exotic mesons in  $Bp$  interactions at 18 GeV/c*. Proc. of the International School of Nuclear Physics, Erice, Italy, 1995. Am and Faessler, Editors, Pergamon, pp. 437-445 (1996).
- R. R. Crittenden, et al., *A 3000 element lead glass electromagnetic calorimeter*. Nucl. Inst. and Meth.

- J. Dowd, *Evidence for  $J^C 1^+$  exotic meson production in the eta piminus system*, proc. Of SLAC Summer School (1997).
- Evidence for exotic meson production in the reaction  $B^+ \rightarrow OBp$  at 18 GeV/c*, Phys. Rev. Lett. Vol. 79, No. 9, p. 1630-1633, Sept. 1997.
- A 3000 element lead glass electromagnetic calorimeter*, Nucl. Instr. Meth. A387, p. 377-394, (1997).
- A cylindrical drift chamber with azimuthal and axial position readout*, Nucl. Instr. Meth., A386, p. 235-248, (1997).
- 854** S. Ahmad, et al., *A Silicon Multiplicity Detector System for an Experiment on the Interaction of Antiprotons with Nuclei at BNL*, IEEE Transaction on Nuclear Science, Vol. 39 (1992) 615-618.
- S. Ahmad, et al., *Antiproton Nucleus Interactions at 5 to 9 GeV/c*, invited contribution at the Second Biennial Conference on Low Energy Antiproton Physics, Courmayeur, Aosta Valley, Italy, Sept. 14-19, 1992. The paper will be published in Nuclear Physics A.
- 857** J. Lowe, et al., *The reaction  $Bp \rightarrow B^0 B^0 n$  near threshold and chiral symmetry breaking*, Proc. of the International Conference on Particles and Nuclei, MIT, June 1990, abstract III-3.
- M.D. Hasinoff, et al., *The reaction  $Bp \rightarrow B^0 B^0 n$  near threshold*, Bull. Am. Phys. Soc. 35, 1209 (1990).
- J. Lowe, et al., *" $Bp \rightarrow B^0 B^0 n$  near threshold and chiral symmetry breaking*, Phys. Rev. C 44, 956 (1991).
- J. Lowe, et al., *The reaction  $Bp \rightarrow B^0 B^0 n$  near threshold and chiral symmetry breaking*, BN Newsletter No. 3, Sept 1991, ed. R.E. Cutkosky, G. Höhler, W. Kluge, B.M.K. Nefkens, p. 47.
- J. Lowe, et al., *The reaction  $Bp \rightarrow B^0 B^0 n$  near threshold and chiral symmetry breaking*, Phys. Rev. C44, 956 (1991).
- H. Burkhardt and J. Lowe, *The global analysis of  $BN \rightarrow BBN$  data*, Phys. Rev. Lett. **67**, 2622 (1991).
- J. Lowe, et al., *The reaction  $Bp \rightarrow B^0 B^0 n$  near threshold and chiral symmetry breaking*, abstract contributed to the Fourth Conference on Intersections between Particle and Nuclear Physics, Tucson AZ, May 24-29, 1991.
- H. Burkhardt and J. Lowe, *A global analysis of  $BN \rightarrow BBN$  data*, invited talk at the Fourth International Symposium on Non-nucleon Physics and the Structure of the Nucleon, Bad Honnef, Germany, September 9-13, 1991, BN Newsletter.
- H. Burkhardt and J. Lowe, *Amplitudes for  $BN \rightarrow BBN$  reactions*, submitted to BN Newsletter.
- 863** H.H. Heckman, et al., *Nuclear Breakup and Particle Densities in 200 A GeV- $^{16}O$  Interactions with Emulsion Nuclei*, Proc. of XVIII Int. Symp. on Multiparticle Dynamics, Tashkent, USSR, Sept. 1987.

- 
- K.B. Bhalla, et al., *Particle Densities and Nuclear Breakup in  $^{16}\text{O}$  - Emulsion Interactions*, Proc. Int. Europhysics Conf. on High Energy Physics, Uppsala, Sweden, June 25-July 1, 1987 (Petit-Lancy, Switzerland: Eur. Phys. Soc. 1987) vol. I, p. 155.
- E. Monnard, et al., *Pseudorapidity Densities in Central  $^{16}\text{O}$  interactions at 200 A GeV*, Proc. Workshop held at Moscow, USSR, August 1987, during the 20th Int. Cosmic Ray Conf., Moscow, Lebedev, 1988 pp. 4-10, 1988.
- M.I. Adamovich, et al., *Multiplicities and rapidity densities in 200 A GeV  $^{16}\text{O}$  interactions with emulsion nuclei*, Phys. Lett. B201, 397 (1988).
- E. Friedlander, et al., *A search for non-statistical fluctuations and structures in the rapidity density distribution of  $^{16}\text{O} + \text{Ag}(\text{BR})$  and  $^{32}\text{S} + \text{Au}$  interactions at 60 and 200 A GeV*. Proc. Hadronic Matter in Collisions, Tucson, Arizona, USA, 1988, pp. 210- 221, Ed: P. Carruthers and J. Rafelski, World Scientific, Singapore.
- S. Garpman, et al., *A computer based coordinate measuring station for nuclear emulsion chambers*, Nucl. Instr. Meth. A269, 134 (1988).
- S. Lokanathan, et al., *The EMU-01 Experiment: A status report*, Proc. Int. Conf. on Physics and Astrophysics of Quark Gluon Plasma, Bombay, India, Feb. 1988, pp. 514- 522, Ed: B. Sinha and S. Raha, World Scientific, Singapore.
- M.I. Tretyakova, et al., *Central intersections of  $^{16}\text{O}$  Nuclei with heavy nuclei of photo-emulsion at 200 GeV/Nucleon*, Lebedev Reprint 244 (1988). Communication at IX Int. Seminar on High Energy Physics Problems-Relativistic Nuclear Physics and Quantum Chromodynamics, Dubna, June 1988.
- R.J. Wilkes, et al., *Pseudorapidity distributions and correlations in central  $^{16}\text{O}$  intersections at 200 A GeV*, Proc. 3rd Conf. on the Intersections between Particle and Nuclear Physics, Rockport, ME, USA, 14-15 May 1988. AIP Conf. Proc. 176, 1047 (1988).
- M.I. Adamovich, et al., *Production of Helium ( $Z=2$ ) Projectile Fragments in  $^{16}\text{O}$  Interactions at 14.6, 60 and 200 A GeV*, Phys. Rev. C. 40, 66 (1989).
- M.I. Adamovich, et al., *Limiting Fragmentation in Oxygen Induced Emulsion Interactions at 14.6, 60 & 200 A GeV*, Phys. Rev. Lett. 62, 2801 (1989).
- M.I. Adamovich, et al., *Scaling Properties of Charged Particle Multiplicity Distribution in Oxygen Induced Emulsion Interactions at 14.6, 60 and 200 A GeV*, Phys. Lett. 223B, 262 (1989).
- M.I. Adamovich, et al., *Charged Particle Spectra in Oxygen Induced Reactions at 14.6 and 60 GeV/Nucleon*, High Energy Physics and Nuclear Physics in China 13, 865 (1989). (English and Chinese).
- M.I. Adamovich, et al., *Rapidity Densities and their Fluctuations in Central 200 A GeV  $^{32}\text{S}$  Interactions with Au and Ag, Br nuclei*, Phys. Lett. 227B, 285 (1989).
- M.I. Adamovich, et al., *A Study of Recoil Protons in Ultra-Relativistic Nucleus-Nucleus Collisions*, Phys. Lett. 230B, 175 (1989).

- E. Ganssauge, et al., *A Track Reconstruction Program (TRP) for Evaluation of Nucleus-Nucleus Collisions in Nuclear Track Emulsion Chambers*, Comp. Phys. Comm. 55, 233 (1989).
- S. Persson, *Measurement and Three-Dimensional Reconstruction of Particle Tracks in Emulsion Chambers*, Comp. Phys. Comm. 55, 103 (1989).
- E. Stenlund, et al., *A Search for Non-Statistical Particle Density Fluctuations in  $^{16}\text{O} + \text{Ag}(\text{Br})$  and  $^{32}\text{S} + \text{Au}$  Interactions at 200 A GeV*, Nucl. Phys. A498, 541c (1989).
- M.I. Adamovich, et al., *On the Energy and Mass Dependence of the Multiplicity in Relativistic Heavy-Ion Interactions*, Modern Physics Letters A5, 169 (1990).
- M.I. Adamovich, et al., *Target Nucleus Fragmentation in  $^{16}\text{O} + (\text{Ag}, \text{Br})$  Interactions at 200 A GeV*, Phys. Lett. 234B, 180 (1990).
- M.I. Adamovich, et al., *On the Multiplicity Fluctuations in Relativistic Heavy-Ion Collisions*, Phys. Lett. 242B, 512 (1990).
- M.I. Adamovich, et al., *Scaled Factorial Moment Analysis of 200 A GeV Sulphur + Gold Interactions*, Phys. Rev. Lett. 65, 412 (1990).
- E. Ganssauge, et al., *Contribution of the EMU01-Collaboration to the research for a Quark Gluon Plasma (QGP)*, Proc. XV Int. Conf. on Particle Tracks in Solids, Marburg, FRG, Sept 3-7, 1990.
- I. Otterlund, et al., *Limiting Fragmentation, Scaling and Substructural Dependence of Multi-particle Production in High-Energy Heavy-Ion Interactions*, Physica Scripta T32, 168 (1990).
- I. Otterlund, et al., *Multiplicity Fluctuations in High-Energy Heavy-Ion Interactions Observed in High-Angular Resolution Tracking Detectors*, to appear in Proc. Santa Fe Workshop on Intermittency in High-Energy Collisions. Santa Fe, NM, March 1990.
- I. Otterlund, et al., *Stochastic Emission and Non-Statistical Fluctuations in Relativistic Heavy-Ion Interactions*, Proc. X Int. Seminar on High Energy Physics Problems--Relativistic Nuclear Physics and Quantum Chromodynamics, Dubna, Sept 1990.
- E. Stenlund, et al., *Non-Statistical Fluctuations in Relativistic Heavy-Ion Collisions*, Proc. CAMP-meeting, Marburg, Germany, May 1990, p. 337.
- E. Stenlund, et al., *Recent Results from EMU01*, Lund University Preprint LUIP 9004 (1990), Proc. HIPAGS Workshop, Brookhaven National Laboratory, Upton, NY, March 5-7, 1990.
- M.I. Tretyakova, et al., *Central Interactions  $\text{S} + \text{AgBr}$  at 200 A GeV*, Proc. X Int. Seminar on High Energy Physics Problems-Relativistic Nuclear Physics and Quantum Chromodynamics, Dubna, Sept 1990.
- J. Wilkes, et al., *Scaled Factorial Moment Analysis of 200 A GeV  $\text{S} + \text{Au}$  Interactions*, to appear in Proc. Santa Fe Workshop on Intermittency in High-Energy Collisions. Santa Fe, New Mexico, March 1990.

---

## Publications

R.J. Wilkes, et al., *Scaled Factorial Moment Analysis of 200 A GeV Sulfur + Gold Interactions*, (EMU-01 Collaboration), Proc. of the Santa Fe Workshop, Intermittency in High Energy Collisions, Los Alamos National Laboratory, Los Alamos, USA, March 18-21, 1990, eds. F. Cooper, R.C. Hwa, I. Sarcevic, World Scientific, p. 145 (1991).

M.I. Adamovich, et al., *Energy, target, projectile and multiplicity dependence of Intermittency behavior in high-energy O(S)-emulsion interactions*, Z Phys. C49:395 (1991).

M.I. Adamovich, et al., *Stochastic Emission of Particles in Ultra-Relativistic Heavy Ion Collisions*, Modern Physics Letters A6:469 (1991).

M.I. Adamovich, et al. *Stochastic Emission of Particles in Ultra-Relativistic Heavy-Ion Collisions*, (EMU-01 Collab.), High Energy Physics and Nuclear Physics in China, 15, 131 (1991).

M.I. Adamovich, et al., *On the Systematic Behavior of the Intermittency-Indices in Nuclear Interactions*, (EMU-01 Collaboration) Phys. Lett. B, 263(3,4), 539-543 (1991).

M.I. Adamovich, et al., *Stochastic Emission of Particles in Ultra-Relativistic Heavy-Ion Collisions*, (EMU-01 Collaboration), Modern Phys. Lett. A. 6(6), 469-478 (1991).

R.J. Wilkes, et al., *Analysis of Fluctuations and Correlations in 200\*A GeV A-A Collisions*, (EMU-01 Collaboration), Proc. 22nd International Cosmic Ray Conference (Dublin, 1991), 4:21.

M.I. Adamovich, et al., *Energy, Target, Projectile and Multiplicity Dependencies of Intermittency Behavior in High Energy O(si,S) induced Interactions*, (EMU-01 Collaboration), Z. Phys. C - Particles and Fields 49, 395-399 (1991).

M.I. Adamovich, et al., *Multiplicities in <sup>16</sup>O-Induced Violent Heavy-Ion Collisions from 5A to 2 x 10<sup>5</sup> A MeV*, (EMU-01 Collab.), Phys. Rev. Lett. 67(10), 1201-1205 (1991).

T.C. Awes, et al., *Review of Recent Results on Particle Production from EMU-01*, R.J. Wilkes and the EMU-012 Collaboration, Nuclear Physics A544:153c, (1992), (invited talk at Quark Matter '91, ed., North Holland, 1992).

V. S. Bhatia, et al., *Emission Characteristics of Helium Fragments in S-Emulsion Interactions at 200 A GeV Energy*. Proc. XXI Int. Symp. on Multiparticle Dynamics, Wuhan, China, Sept. 23-27, 1991, p. 623-626. (World Scientific, Singapore, 1992, Eds.: Wu Yuanfang and Liu Lianshou.)

I. Otterlund, et al., *The Energy Dependence of Particle Densities and Multiplicities in Violent Nucleus-Nucleus Collisions*. Proc. XXI Int. Symp. on Multiparticle Dynamics, Wuhan, China, Sept. 23-27, 1991. p. 573-581. (World Scientific, Singapore, 1992, Eds.: Wu Yuanfang and Liu Lianshou).

R. J. Wilkes, et al., *Review of Recent Results on Particle Production from EMU01*. Proc. Quark Matter '91, Gatlinburg, Tennessee, November 11-15, 1991. Nucl. Phys. A544 (1992) 153c.

S. Garpman, et al., *Linear and Non-Linear Aspects of Relativistic Heavy-Ion Interactions from EMU01 results*. Proc. 7th Int. Symp. on Very High Energy Cosmic Ray Interactions, Ann Arbor, Michigan, USA, June 21-27, 1992.

**Publications**

I Otterlund, et al., *EMU01 Results from Oxygen, Silicon and Sulphur Induced Violent Interactions at BNL-AGS and CERN-SPS*. Proc. Int. Conf. on Hadron Structure '92, Stará Lesná, Czechoslovakia, Sept 6-11, 1992, p. 244- (Košice, 1992, eds.: D. Bruncko and J Urban).

M. I. Adamovich, et al., *A systematic study of the energy independent behavior of the fragmentation regions in 0-16 EM interactions from 3.7-A-GeV to 200-A-GeV*. Z. Phys. C55 (1992) 235-24.

M. I. Adamovich, et al., *A Systematic Investigation of Scaled Factorial Cumulant Moments for Nucleus-Nucleus Interactions*, (EMU-01 Collaboration) Physical Review D 47:3726 (1993).

M. I. Adamovich, et al., *On the jet-like and ring-like substructure in distributions of produced particles in central heavy ion collisions at ultrarelativistic energies*. J. Phys. G19:2035-2044, 1993.

E. Stenlund, et al., *Pseudorapidity Distributions and Azimuthal Substructure in Heavy Ion and Very Heavy Ion Collisions at Energies up to 200 A GeV*. Proc. 22nd Int. Symp. on Multiparticle Dynamics, Santiago de Compostella, Spain, July 13-17, 1992. p. 349-365. World Scientific, Singapore, 1993, Ed.: C.Pajares).

I. Otterlund, et al., *Gentle and Violent Gold Interactions from the BNL-AGS*. Proc. Heavy Ion Physics at the AGS, HIPAGS'93, Massachusetts Institute of Technology, Cambridge, MA, January 13-15, 1993. MITLNS-2157, pp. 1. (Eds. S. G. F. Stephans, S. G. Steadman and W. L. Kehoe).

J. Nystrand, et al., *Rapidity Density Distributions in  $^{16}O$ ,  $^{28}Si$ , and  $^{197}Au$  Induced High Energy Heavy Ion Interactions*, Proc. 2<sup>nd</sup> Int. Conf. on Physics and Astrophysics of Quark-Gluon Plasma, Calcutta, India, January 19-23, 1994. pp. 462 (World Scientific, Singapore, 1994), Eds.: B. Sinha, Y. P. Vijoyi and S. Raha).

E. Stenlund, et al., *Violent Au-Induced Collisions at the BNL-AGS and Comparisons with Expectations from Particle Densities and their Fluctuations in Collisions with Lighter Systems*. Proc. Cracow Workshop on Multiparticle Productions - Soft Physics and Fluctuations, Cracow, Poland, May 4-7, 1993. (World Scientific, Singapore, 1994, Eds.: A. Bialas, K. Fialkowski, K. Zalewski and R. C. Hwa.)

S. Garpman, et al., *Multiparticle Production in Energetic Nucleus-Nucleus Collisions*, Proc. Hadron Structure '93 Int. Conf., Banská Štiavnica, Slovakia, Sept 5-10, 1993. pp. 83. (Bratislava 1993, Eds.: S. Dubnicka and A. Z. Dubnickova).

S. Vokal, et al., *Interactions of 14.6 A GeV/c Silicon Nuclei in Nuclear Emulsion*, Proc. Hadron Structure '93 Int. Conf., Banská Štiavnica, Slovakia, Sept 5-10, 1993. pp. 93. (Bratislava 1993, Eds.: S. Dubnicka and A. Z. Dubnickova).

J. Nystrand, et al., *Rapidity Density Distributions in Au+ Au and Au+ Ag Interactions at 11.6 A GeV/c*. Proc. Quark Matter '93, Borlänge, Sweden, June 20-24, 1993. Nucl. Phys. A566 (1994) 419c.

R. J. Wilkes, et al., *Systematics of Pseudorapidity Distributions*. Proc. 23rd Int. Cosmic Ray Conf., Calgary, Canada, July 1993.

V. Navotny, et al., *Rapidity and Azimuthal Correlations in Relativistic Heavy-Ion Interactions at 4-200 GeV/Nucleon*. Proc. VIII Int. Symp. on , Japan, July 24-20, 1994, pp. 339.

## Publications

---

X. Cai, et al., *Fluctuations and Correlations of Particles Produced in Ultra-High-Energy Heavy-Ion Induced*

*Interactions*. Proc. First Int. Symp. on Cosmic Ray Physics in Tibet (ISCRP), Lhasa, China, Aug. 12-17, 1994.

E. Stenlund, et al., *Aspects on Au-Induced Interactions with Emulsion and Heavy Nuclei at 11.6 A GeV*. Proc. Int. Conf. on Hadron Structure '94, Košice, Slovakia, Sept. 19-23, 1994 (Košice 1994, eds.: J. Urbán and J. Vrláková) pp. 188.

M. I. Tretyakova, et al., *Factorial Moments in Central Si+ Ag, Br Interactions at 14.6 A GeV/c*. Proc. Int. Conf. on Hadron Structure '94, Košice, Slovakia, Sept. 19-23, 1994 (Košice 1994, eds.: J. Urbán and J. Vrláková)

E. Stenlund, et al., *Particle Production in Gold and Lead Induced Interactions at AGS and SPS*. Proc. Quark Matter '95, Monterey, CA, USA, 9-13 January, 1995.

**864** C. F. Baillie, et al., *A new MCRG calculation of the critical behavior of the 3-D ising model: Preliminary results*, Nucl. Phys. Proc. Suppl. 17, p. 323-327, 1990.

T. A. Armstrong, et al., *Strangelets, antimatter and coalescence: First results from BNL E864*, Nucl. Phys. A610, 297c, 1996.

C.A. Pruneau, et al., *The E864 lead-scintillating fiber hadronic calorimeter*, VI Intl. Conf. On Calorimetry in High-energy Physics, Frascati, Italy, June 1996.

J. G. Lajoie, et al., *Cross sections for  $K^-$  and antiproton production in 11.6 GeV/c per nucleon Au+ Pb collisions*, Heavy Ion Physics 4, 1996, Budapest, Hungary.

K. N. Barish, et al., *First search for charged strangelets with the E864 spectrometer*, Heavy Ion Physics 4, 423, 1996, Budapest, Hungary

P. Haridas, I. A. Pless, G. Van Buren, J. Tomasi, M.S.Z. Rabin, K. Barish, R. D. Majka, *A 10 MHz beam counter and a multiplicity detector for the E864 spectrometer*, Nucl. Instr. and Meth. A385, 412, 1997.

T. A. Armstrong, et al., *Search for exotic strange quark matter in high-energy nuclear reactions*, Nucl. Phys. A625, 494, 1997.

T. A. Armstrong, et al., *Antiproton production in 11.5 A-GeV/c AU + PB nucleus-nucleus collisions*, NUCLEX-9709005, Sept. 1997 4pp., Phys. Rev. Lett. 79, p. 3351-3354, 1997.

K. N. Barish (for the collaboration), *Strangelet searches in high-energy heavy ion collisions*, NUCLEX-9711006, Nov. 1997 10pp. Contributed to 6th Intl. Conf. On Hypernuclear and Strange Particle Physics (HYP 97), Upton, NY, Oct. 13-18, 1997.

T. A. Armstrong, et al., *Search for charged strange quark matter produced in 11.5 A GeV/c Au + Pb Nucleus collisions*, Phys. Rev. Lett. 79, 3612, 1997.

P. Haridas, et al., *A 10 MHz beam counter and a multiplicity detector for the E864 spectrometer*, Nucl. Instr. Meth. A385, 412 (1997).

T. A. Armstrong, et al., *the E864 lead-scintillating fiber hadronic calorimeter*, (accepted-1997).

**Publications**



- K. Barish, et al., *The E864 lead-scintillating fiber hadronic calorimeter*, accepted for publication by Nucl. Instrum. And meth.
- 865** N. J Baker, et al., *Search for short-live neutral particles emitted in  $K^+$  decay*, Phys. Rev. Lett. Vol. 59, No. 25, p. 2832-2835, Dec. 21, 1987.
- C. Campagnari, *Search for the decay  $K^+ \rightarrow 6B^+ \mu^+ e^-$* , Phys. Rev. Lett. Vol. 61, No. 18, p. 2062-2065, Oct 31, 1988.
- A. M. Lee, et al., *Improved limit on the branching ratio of  $K^+ \rightarrow 6B^+ \mu^+ e^-$* , Phys. Rev. Lett. Vol. 64, No. 2, p 165-168, Jan. 8, 1990.
- D. M. Lazarus, *Results/prospects in E777/851/865*, 2nd Intl. Workshop on Heavy Quark Physics in Fixed Targets, U. Va., Charlottesville, VA., HQ94, Oct 6-10, 1994.
- 866** M. Gonin, *First results with the Au-beam at the AGS*, Proc. Intl. Nuclear Physics Conf., Wiesbaden, Germany, July 26-Aug. 1, 1992, Nucl. Phys. A 533, 799c-812c (1993).
- H. Hamagaki (for the E866 collaboration), *Semi-inclusive hadron spectra with beams of Si and Au at the AGS*, BNL-49476, proc. 10th Intl. Conf. Of Ultra-Relativistic Collisions (Quark Matter 1993), Borlange, Sweden, June 20-24, 1993, Nucl. Phys. A 566, 27c-34c (1994)..
- M. N. Nambodiri (for the E866 collaboration), *Backward emission of protons in Au+ Au collisions at 11.7 A-GeV/c*, BNL-49674, Proc. 10th Intl. Conf. Of Ultra-Relativistic Collisions (Quark Matter 1993), Borlange, Sweden, June 20-24, 1993, Nucl. Phys. A 566, 443-6c (1994)..
- B. Moskowitz and M. Gonin (for the E866 collaboration), *Distributions of transverse energy, protons, and mesons from Au+ Au collisions at 11.6A GeV/c*, BNL-49498, Proc. 13th Particles and Nuclei Intl. Conf., (PANIC93), Perugia, Italy, June 28-July 2, 1993.
- B. Moskowitz, et al., (for E802/E866 collaboration), *Global Transverse and forward Energy measurements for Si+ A and Au+ A at the AGS*, Proc. Heavy Ion Physics at the AGS, Jan. 13-15, 1993, Cambridge, MA, ed. G.S.F. Stephans, S.G. Steadman and W.L. Keohoe, MITLNS-2158, pp. 21-9 1993).
- J. B. Costales, H.C. Britt, M.N. Nambodiri, T.C. Sangster, J.H. Thomas, and H.E. Wegner, *A phoswich array for relativistic heavy ion collisions*, Nucl. Instr. And Meth. A330, 183-94 (1993).
- M. Gonin, et al., (for E802/E866 collaboration), *Baryon distributions from meson production in Au+ Au at 11.6 A GeV/c. First particle spectra from E866*, Proc. 10th Intl. conf. on Ultra-Relativistic Nucleus-Nucleus Collisions (Quark Matter '93), June 20-24, 1993, Borlange, Sweden, Nucl. Phys. A566, 601c-4c (1994).
- C. Sangster, et al., (for E802 collaboration), *Targetrapidity baryon distributions in  $^{28}\text{Si}+^{197}\text{Au}+^{197}\text{Au}$  collisions at 14.6 and 11.7 A. GeV/c.*, Proc. Heavy Ion Physics at the AGS, Jan. 13-15, 1993, Cambridge, MA., ed. G.S.F. Stephans, S.G. Steadman and W.L. Kehoe, MITLNS-2158, pp. 61-71 (1993).
- M. Gonin, O. Hansen, B. Moskowitz, F. Videbaek, H. Sorge and R. Mattiello, *Comparison of experimental data to the relativistic quantum molecular dynamics model for Si+ qu collisions at 14.6 A GeV/c*, Phys. Rev. C 51, 310-7 (1994).

---

## Publications

B. Moskowitz, et al., (for E802/E866 collaboration), *Proton and produced particle distributions from Au+ Au collisions at 11.6 A GeV/c*, Proc. 8th Mtg. Division of Particle and fields, Aug. 2-6, 1994, Albuquerque, New Mexico.

R. Debbe, S. Gushue, B. Moskowitz, J. Norris, J. O'neiss, F. Videbaek, *In beam tests of a ring imaging Cerenkov detector with a multianode photomultiplier readout*, Nucl. Instrum. Meth. A 362, 253-60 (1995).

Z. Chen, et al., (for E802 collaboration), *Recent results of E866 on hadron production in Au+ Au reaction at AGS energies*, Proc. First Intl. Conf. On Frontiers of Physics, Aug. 5-9, 1995, Shantou, China.

K. Shigaki, et al., (for E802 collaboration), *Study of hadron production in Au+ Au collisions at 11 A GeV/c with the AGS E866 forward spectrometer*, Proc. 11th Intl. Conf. On Ultra-relativistic Nucleus-Nucleus Collisions, (quark Matter '95), Jan. 9-13, 1995, Monterey, Calif., Nucl. Phys. A 590, 519c-22c (1995).

Y. Akiba, et al., *Particle production in Au+ Au collisions from BNL E866*, Proc. Of Quark Matter '96 -12th Intl. Conf. On Ultra-Relativistic Nucleus-Nucleus Collisions, May 20-24, 1996, Heidelberg, Germany, Nucl. Phys. A610, 139c-152c (1996).

K. Kurita, et al., *Azimuthal asymmetry of particle production in Au+ Au collisions at 11.6 A GeV/c*, Proc. Of Heavy Ion Physics at the AGS (HIPAGS'96), Aug. 22-24, 1996, Detroit, Michigan.

Z. Chen, et al., *Hadronic spectra in Au+ Au reactions at 11.6 A GeV/c: rapidity and  $m_t$  distributions*, Proc. Of heavy Ion Physics at the AGS (HIPAGS'96), Aug. 22-24, 1996, Detroit, Michigan.

H. Sako, et al., *Antiproton production in 11.7 A GeV/c Au+ Au collisions from E866*, Proc. Of heavy Ion Physics at the AGS (HIPAGS'96) Aug. 22-24, 1996, Detroit, Michigan.

K. Ashktorab, et al., *Composite particle production in relativistic Au+ Au collisions at AGS: first results from the E866 forward spectrometer @ 2, 4 and 10.8 A GeV*, Proc. of Heavy Ion Physics at the AGS (HIPAGS'96), Aug. 22-24, 1996, Detroit, Michigan.

L. Ahle, et al., *Baryon emission at target rapidities in Si+ A1, Cu, Au collisions at 14.6 A GeV/c and Au+ Au collisions at 11.7 A GeV/c*, Phys. Rev. C55 (5), 2604-2614 (1997).

R. Debbe, C. Muentz, J.B. Cummings, *A high resolution quartz Cerenkov detector for relativistic heavy ion beams*, Nucl. Instrum. Meth. (Submitted)

L. Ahle, et al., *Particle production at high baryon density in central Au+ Au reactions at 11.6 A GeV/c*, Phys. Rev. C: Rapid communications (submitted)

## 868 KLMM Collaboration

W. Wolter, et al., *Evidence for a critical temperature in excited target nuclei due to high energy nuclear interactions*, 23rd ICRC Calgary, Canada, vol. 4, p. 5-8 (1993).

R. Holynski, et al., *Comparison of particle production in nucleus-nucleus collisions with predictions of the Venus Monte Carlo model*, 23rd ICRC, Calgary, Canada, vol. 4, p. 9-12 (1993).

R. Holynski, et al., *Evidence for a nuclear phase transition in target nuclei after relativistic nuclear interactions*, A. Dabrowska, Zeitschrift fur Physik, Parts. and Fields, 59(3), 399-403 (1993).

**Publications**

- K. Sengupta, *et al.*, *Multifractal analysis of nucleus-nucleus interactions*, Phys. Rev. C 48, 3174-3181 (1993).
- M. L. Cherry, *et al.*, *Interactions of 10.6 GeV/nucleon gold nuclei in nuclear emulsions*, Zeitschrift für Physik, C62, 25, (1994).
- M. L. Cherry, *et al.*, *Interactions of 10.6 GeV/n gold nuclei with light and heavy target nuclei in nuclear emulsions*, Zeitschrift für Physik, C63, 549 (1994).
- M. L. Cherry, *et al.*, *Fragmentation and multifragmentation of 10.6 A GeV gold nuclei*, Phys. Rev. C52, 2652-2662 (1995).
- M. L. Cherry, *et al.*, *Intermittency in  $^{197}\text{Au}$  fragmentation*, Phys. Rev. C53, 1532 (1996).
- M. L. Cherry, *et al.*, *Transverse Momenta of Helium fragments in Gold Fragmentation at 10.6 GeV/nucleon*, Zeitschrift für Physik, 73, 449 (1997).
- B. Wilczynska, *et al.*, *Transverse momenta of helium fragments from gold projectiles in selected classes of nucleus-nucleus collisions*, 25th ICRC, Durban, Vol. 6, p. 13-15, 1997.

## 869 UHIC Collaboration

- C. Jake Waddington, *Some preliminary results from the new 10.6 GeV/nucleon gold beam at Brookhaven*, Inter. J. of Mod. Phys. E, Vol. 2, No. 4, 739-766 1993.
- L. Y. Geer, J Klarmann, B. S. Nilsen, C. J Waddington, W. R. Binns, J R. Cummings and T. L. Garrard, *Energy dependence of the fragmentation of UH-nuclei*, 23rd ICRC, Calgary, Canada, vol. 2, p. 191-194 1993.
- L. Y. Geer, J Klarmann, B. S. Nilsen, C. J Waddington, W. R. Binns, J R. Cummings, and T. L. Garrard, *Energy dependence of the fragmentation of UH-nuclei*, 23rd Int. Cosmic Ray Conf., Calgary, Canada, vol. 2, p. 191-194 1993.
- B. S. Nilsen, C. J Waddington, W. R. Binns, J R. Cummings, T. L. Garrard, L. Y. Geer, and J Klarmann, *Charge-pickup by heavy relativistic nuclei*, Phys. Rev. C50, 1065-1076 1994.
- J Waddington, W. R. Binns, J R. Cummings, T. L. Garrard, B. W. Gauld, L. Y. Geer, J Klarmann, and B. S. Nilsen, *Interactions of 10.6 GeV/n gold nuclei in targets from  $^1\text{H}$  to  $^{82}\text{Pb}$* , C. Nucl. Phys. A566, 427c-430c 1994.
- L. Y. Geer, J Klarmann, B. S. Nilsen, C. J Waddington, W. R. Binns, J R. Cummings and T. L. Garrard, *The Charge-changing Fragmentation of 10.6 GeV/nucleon  $^{197}\text{Au}$  Nuclei*, Phys. Rev. C52, 334-345, 1995.
- C. J Waddington, W. R. Binns, J R. Cummings, T. L. Garrard, L. Y Geer, J Klarmann and B. S. Nilsen, *Nuclear parameters needed for interpretation of observed fluxes of UH-cosmic ray nuclei*, Adv. Space Res., 15, No. 6, 39-48 1995.
- C. J Waddington, *The propagation of UH cosmic ray nuclei using energy dependent cross sections*, Astrophys. J., 470, 1218-1226, 1996.

## Publications

---

- C. J Waddington, J R. Cummings, T. Garrard, P. Hink and B. S. Nilsen, *Propagation of the heaviest UH cosmic ray nuclei*, 25th ICRC, Durban, Vol. 4, p. 345-348, 1997.

- C. J Waddington, *Can source abundances be reliably deduced from measured cosmic ray abundances?*, 25th ICRC, Durban, Vol. 4, p.341-344, 1997.
- 871** A. P. Heinson, et al., *Measurement of the branching ratio for the rare decay  $K_L^0 \rightarrow \mu^+ \mu^- \mu^+ \mu^-$* , Phys. Rev. D, Vol 51, No. 3p.985-1011, Feb. 1995.
- 874** C. Kormanyos, et al. *Nuclear Response to Quasifree  $K^+$  Scattering*, submitted to Spring Meeting- American Physical Society, April 12-15, 1993.
- C. M. Kormanyos, et al., *Nuclear Quasi Elastic  $K^+$  Scattering*, Phys. Rev. Lett 71, 2571 (1993).
- C. Kormanyos, et al., *Quasi Elastic  $K^+$  Scattering*, Phys. Rev. C51 669 (1995).
- C. M. Kormanyos and R. J Peterson, *Quasi Elastic  $K^+$  Nucleus Scattering and 'Swollen Nucleons'*, Nucl. Phys. A 585, 113 (1995)."
- 875** A. Mukhopadhyay, P. L. Jain and G. Singh, *Multiplicity distributions in high-energy heavy-ion collisions*, Nuova Cim. 106A, 967-978 (1993).
- P. L. Jain, G. Singh and A. Mukhopadhyay, *Fractal analysis of projectile fragments in nuclear collisions at 1-2A GeV*, Nucl. Phys. A561, 651-659 (1993).
- A. Mukhopadhyay, P. L. Jain and G. Singh, *Multiplicity distributions in forward and backward hemispheres at high energy collisions*, Nuova Cim. A106, 793-811 (1993).
- A. Mukhopadhyay, G. Singh and P. L. Jain, *Cluster formation in high energy collisions*, Phys. G, 19, 1137-1142 (1993).
- P. L. Jain, G. Singh and A. Mukhopadhyay, *Factorial moments and multifractal analysis at relativistic energies*, Phys. Rev. C48, R517-R521 (1993).
- G. Singh, A. Mukhopadhyay and P. L. Jain, *Z., Intermittency and fractals in nuclear collisions at 1.52A GeV*, Phys. A345, 305 (1993).
- P. L. Jain and G. Singh, *Multifragment disintegration of  $^{238}\text{U}$  at 1A GeV*, Phys. Rev. C47, 2382-2385 (1993).
- P.L. Jain, A. Mukhopadhyay and G. Singh, *Z., Factorial moments and short range correlational relativistic energies*, Phys. C58, 1 (1993).
- M. Golde, G. Singh, P. L. Jain, and A. Mukhopadhyay, *Z., Characteristics of He-nucleus interactions at relativistic energy*, Phys. A344, 291 (1993).
- G. Singh, P. L. Jain and M. S. El-Nagdy, *Intermittency analysis in nuclear multifragmentation*, Europhys. Lett. 21, 527 (1993).

## Publications

- 
- P. L. Jain, G. Singh and A. Mukhopadhyay, *Intermittent behavior of nuclear multigragsments*, Phys. Rev. C47, 342 (1993).
- A. Mukhopadhyay, P. L. Jain and G. Singh, *Entropy and fractal characteristics of multiplicity production at relativistic heavy ion interactions*, Phys. Rev. C47, 410 (1993).

G. Singh and P. L. Jain, *Multifractal analysis of  $^{197}\text{Au}$ -emulsion collisions at 10.6A GeV*, Phys. Rev. C (1994).

P. L. Jain, G. Singh, and A. Mukhopadhyay, *Nuclear Collective Flow in  $^{197}\text{Au}$ -Emulsion Interaction at 10.6A GeV*. Phys. Rev. Letts. 74, 1534 (1995).

P. L. Jain and G. Singh. *Characteristics of charged particle multiplicities distribution in relativistic heavy-ion interactions*. Phys. Rev. c (1996).

P. L. Jain and G. Singh. *Liquid-Gas Coexistence in  $^{208}\text{Pb}$ -Emulsion Interactions at 160A GeV*. Phys. Lett. B (1996).

G. Singh and P. L. Jain., *Target and projectile fragmentations in  $^{208}\text{Pb}$ -Emulsion collisions at 160A GeV*, Phys. Rev. C (1996).

**877** J Barrette, et al., *Transverse Energy Production in Reactions with 11.4 A GeV/c Au and 14.6 A GeV/c Si*, the E814/E877 collaboration, Phys. Rev. Lett. 70 (1993) 2996.

P. Braun-Munzinger, et al., (for E877 collaboration), *Compression, expansion, and freeze out in nucleus-nucleus collisions at the AGS*, in Bodrum 1993, Proc., Hot and dense nuclear matter, 419-426.

J. Barrette, et al., (for E877 collaboration), *Transverse energy production with SI and AU beams at AGS energy: towards hot and dense hadronic matter*, Nucl. Phys. A566, pp 411c-414c, 1994.

J. P. Wessels and Y. C. Zhang, the E877 collaboration, *Is there Flow at the AGS?*, Proc. 10th Winter Workshop on Nuclear Dynamics, Snowbird, Utah, Jan. 1994, W. Bauer, editor, World Scientific, Singapore 1994, p. 228.

J. Barrette, et al., *Observations of Anisotropic Event Shapes and Transverse Flow in Au+ Au Collisions at AGS Energy*, the E877 collaboration, Phys. Rev. Lett. 73 (1994) 2532.

J. Barrette, et al., *Charged Particle Pseudorapidity Distributions in Au+ Al, Cu, Au, and U Collisions at 10.8 A GeV/c*, the E877 collaboration, Phys. Rev. C651 (1995) 3309.

J. Barrette, et al., the E877 collaboration, *Directed Flow and Particle Production in Au+ Au Collisions from Experiment E877 at the AGS*, Nucl. Phys. A590, pp 259c-270, 1995.

Y. C. Zhang and J. P. Wessels, the E877 collaboration, *Energy Flow and Particle Spectra with respect to the Reaction Plane for Au+ Au Collisions at AGS Energies*, Nucl. Phys. A590, pp 557c-650c, 1995.

D. Miskowicz, the E877 collaboration, *Pion-Pion Correlations in Au+ Au Collisions at AGS Energy*, Nucl. Phys. A590, pp 605c-608c, 1995.

## Publications

---

Sergei Voloshin, the E877 collaboration,  *$dN_{ch}/d\phi$  Distributions in Au+ Al, Cu, Au, and U Collisions at 10.8 A GeV/c and  $E_t$  per Charge Particle*, Nucl. Phys. A590, pp 605c-608c, 1995.

R. Lacasse, et al., (for the E877 collaboration) *Hadron yields and spectra in Au + AU collisions at the AGS*, NUCLEX-9609001, May 1996, 12pp, Presented at 12th Intl. Conf. Ultra-Relativistic Nucleus-Nucleus Collisions (quark Matter 96), Heidelberg, Germany, May 20-24, 1996, Nucl. Phys., A610, pp 153c-164c, 1996.

J. Barrette, et al., (for E877 collaboration), *Two pion correlations in AU + AU collisions at 10.8 GeV/c per nucleon*, PHYSICS-9702008, Feb. 1997 5pp, Phys. Rev. Lett 78, pp 2916-2919, 1997.

J. Barrette, et al., (for E877 collaboration), *Energy and charged particle flow in a 10.8-A/GeV/c AU + AU collisions*, NUCLEX-9610006, Oct. 1996 12pp, Phys. Rev. C55, pp 1420-1430, 1997.

J. Barrette, et al., (for E877 collaboration), *Proton and pion production relative to the reaction plane in AU + AU collisions at AGS energies*, HD-PY-97-07, July 1997 35pp.

**880** T. Roser, *Properties of partially excited siberian snake*, in *High Energy Spin Physics: 8th Intl. Symposium*, ed. K. J. Heller, Minneapolis, MN, 988, AIP Conf. Proc. No. 187 (AIP, New York, 1989), p.1442.

H. Huang, et al., *The Partial Siberian Snake Experiment at the Brookhaven AGS*, *Proc. of the third European Particle Accelerator Conf.*, p. 729 (1992).

H. Huang, et al., *Preservation of Proton Polarization by a Partial Siberian Snake*, *Physical Review Letters* 73, 2982 (1994).

H. Huang, et al., *Partial Siberian Snake Experiment at the AGS*, in *High Energy Spin Physics: 11th Intl. Symposium*, ed. K. J. Heller and K. J. Smith, Bloomington, 1994, AIP Conf. Proc. No.343 (AIP, New York, 1995), p. 90.

T. Roser, *Polarized Proton Beams*, *Proc. of the 1995 IEEE Particle Accelerator Conf and Intl. Conf on High-Energy Accelerators*, 3154 (1996).

H. Huang, et al., *Polarized proton experiment in the AGS with a partial snake*, *proc. of 12th Intl. Symposium on High Energy Spin Physics*, Amsterdam, 528-530, Sept. 1996.

H. Huang, et al., *Overcoming weak intrinsic depolarizing resonances with energy jump*, 1997 IEEE Particle Accel. Conf., and Intl. Conf. On High Energy Accelerators, Vancouver, Canada, May, 1997.

M. Bai, et al., *Overcoming intrinsic spin resonance by using an AC dipole*, 1997 IEEE Particle Accelerator Conf. And Intl. Conf. On High Energy Accelerators, Vancouver, Canada, May 1997.

M. Bai, et al., *Overcoming the intrinsic spin resonance using resonance island created by RF dipole*, to be submitted to *Physical Review* (1997).

M. Bai, et al., *Experimental test of coherent betatron resonance excitations*, *Physical Review E*, 5 (1997).

## Publications

---

**881** C. Landberg, et al., *Test of the OZI rule in hadroproduction of NN and NK<sup>+</sup>K<sup>-</sup>*, *Phys. Rev. D*53, pp. 2839-2842 (1996).

**882A** Y. D. He and P. B. Price, *Measurement of cross section for charge pickup by 11.4 A GeV gold ions*, *Phys. Lett. B* 298, 50-53 (1993).

P. B. Price and Y. D. He, *Interactions of 11.4 A GeV<sup>197</sup>Au in various targets*, *Proceedings of 23<sup>rd</sup> International Cosmic Ray Conference*, Calgary, **2**, 199-202 (1993).

A. J. Westphal and Y. D. He, *Measurement of cross sections for electron capture and stripping by highly relativistic ions*, Phys. Rev. Lett. 71, 1160-1163 (1993).

Y. D. He and P. B. Price, *First measurement of charge-changing cross sections for 11.4 A GeV<sup>197</sup>Au in various targets*, Nucl. Phys. A 566, 363c-366c (1994).

Y. D. He and P. B. Price, *Nuclear and electromagnetic fragmentation of 2.25-TeV<sup>197</sup>Au nuclei*, Z. Phys. A 348, 105-109 (1994).

Y. D. He, A. J. Westphal, and P. B. Price, *Response of the BP-1 phosphate glass detector to relativistic heavy ions*, Nucl. Instr. Meth. B 84, 67-76 (1994)

A. J. Westphal, Y. D. He, and P. Wojdowski, *Apparent binary microscopic response to relativistic ions of a large class of track-etch detectors*, Nucl. Instr. Meth. B 86, 317-324 (1994).

M. Drndic, Y. D. He, P. B. Price, D. P. Snowden-Ifft, and A. J. Westphal, *Atomic-force-microscopic study of etched nuclear tracks at extremely short distance scale*, Nucl. Instr. Meth. B 93, 52-56 (1994).

Y. D. He and M. Solarz, *Sensitivity of BP-1 glass detectors etched in methanesulfonic acid*, Nucl. Instr. Meth. B 94, 113-118 (1994).

**882B** Y. D. He and P. B. Price, *Search for abnormal-nucleus production in heavy-ion collisions*, Phys. Rev. C 48, 647-650 (1993).

Y. D. He and P. B. Price, *Search for Dirac magnetic monopole production in high energy heavy ion collisions*, *Proceedings of 24<sup>th</sup> International Cosmic Ray Conference*, Rome, 1, 845-848 (1995).

Y. D. He and P. B. Price, *Production and detection of hyperfragments in high energy nucleus-nucleus collisions*, *Proceedings of 24<sup>th</sup> International Cosmic Ray Conference*, Rome, 1, 64-67 (1995).

Y. D. He, *Search for a Dirac magnetic monopole production in high energy nucleus-nucleus collisions*, submitted to Phys. Rev. Lett (1997).

Y. D. He and P. B. Price *Search for short-lived and negatively charged strangelets in highly relativistic heavy ion collisions*, in preparation (1997).

Y. D. He and P. B. Price, *Electromagnetic production of hyperfragments in ultrarelativistic heavy-ion collisions*, Nucl. Phys. A 585, 363c-364c (1995).

## Publications

---

Y. D. He and P. B. Price, *Production and detection of hyperfragments in high energy nucleus-nucleus collisions*, *Proceedings of 24<sup>th</sup> International Cosmic Ray Conference*, Rome, 1, 64-67 (1995).

Y. D. He and P. B. Price, *Search for Dirac magnetic monopole production in high energy heavy ion collisions*, *Proceedings of 24<sup>th</sup> International Cosmic Ray Conference*, Rome, 1, 845-848 (1995).

**883** S. E. Hirzebruch, G. Rusch, E. Winkel, and W. Heinrich, *Response of BP-1 to <sup>197</sup>Au heavy ions at 11.3 GeV/nucleon*, NIM B74 (1993) 519-522.

- W. Heinrich, E. Winkel, G. Rusch, J. Dreute, and B. Wiegand, *Multifragmentation experiments using plastic nuclear track detectors*, Proc. Int. Workshop XXII, Hirschegg, p. 30 (1994).
- G. Hüntrop, D. Weidmann, S. E. Hirzebruch, E. Winkel, W. Heinrich, *Search for fractionally charged nuclear fragments in relativistic heavy ion collisions*, submitted to Nucl. Phys. A.
- W. Heinrich, E. Becker, J. Dreute, S. E. Hirzebruch, G. Hüntrop, M. Kurth, H. Röcher, G. Rusch, M. Schmitz, T. Streibel and E. Winkel, *High energy heavy ion interactions studied with SSNTDs, Radiation Measurements*, Vol. 25, Nos. 1-4, pp. 203-218, 1995.
- 885** L. Lee, et al., *A multicell target for lambda lambda hypernuclei searches*, by BNL E885 Collaboration, TRI-PP-94-87, Oct. 1994. 2pp, presented at Intl. Conf. on Hypernuclear and Strange Particle Physics (HYP94), Vancouver, Canada, July 4-8, 1994. Published in Nucl. Phys. A585:339c-340c, 1995 (Bassalleck first author).
- 886** G.E. Diebold, et al., *Production of  $B^\pm$ ,  $K^\pm$ ,  $p$ , and  $\bar{p}$  in relativistic  $Au + Pt$ ,  $Si + Pt$  and  $p + Pt$  collisions*, Phys. Rev. C, 48, 2984 (1993).
- N. Saito, et al., *Composite particle production in relativistic  $Au + Pt$ ,  $Si + Pt$  and  $p + Pt$  collisions*, Phys. Rev. C49, 3211 (1994).
- A. Rusek, et al., *Search for strangelets and other rare objects in  $Au + Pt$  collisions at the AGS using a fixed-angle focusing spectrometer*. Proceedings of International Conference on Hypernuclear and Strange Particle Physics, Vancouver, Canada, July 1994. Nuc. Phys. A 585, 59C (1995).
- A. Rusek, et al., *Search for  $H$  dibaryon-nucleus bound states in relativistic  $Au + Pt$  collisions*. PRC C5, 1580 (1995).
- Adam Rusek, *A Search for Strangelets and Other Rare Objects in Relativistic  $Au + Pt$  Collisions*. Dissertation submitted in partial fulfillment of the Requirements for the Degree of Ph.D. in Physics. The University of New Mexico, Albuquerque, NM, December 1995.
- A. Rusek, et al., (for E886 collaboration), *Search for  $H$  dibaryon nucleus bound states in relativistic  $AU + PT$  collisions*, Phys. Rev. C52, p. 1580-1583, 1995.
- A. Rusek, et al., (for E886 collaboration), *Strangelet search and light nucleus production in relativistic  $SI + PI$  and  $AU + PT$  collisions*, Phys. Rev. C54, p 15-19, 1996.
- 887** R. Sawafra, et al., *Do narrow sigma hypernuclear states exist? AGS proposal*, BNL-Proposal-887, Jan. 1992, 18pp., Nucl. Phys. A585, p. 103c-108c, 1995.

## Publications

- 
- 888** J. Belz, et al., *Search for the Weak Decay of an  $H$  Dibaryon*. PRINCETON/HEP/95-12, UTEXAS-HEP-95-19 (1995).
- J. Belz, et al., *Search for Diffractive Dissociation of a Long-lived  $H$  Dibaryon*. PRINCETON/HEP/95-11 (1995).
- J. Belz, et al., *Search for diffractive dissociation of long-lived  $H$  dibaryon*, Phys. Rev. D, R3487-91 (1996).
- J. Belz, et al., *Search for the Weak Decay of an  $H$  Dibaryon*, Phys Rev. Letts., 76, 3277-80 (1996).



- 890** M. Clajus, et al., *Eta production in pion interactions with protons and deuterons*, Proc. 6th Intl. Symposium on Meson-Nucleon Physics and the Structure of the Nucleon, Blaubeuren, Germany, July 10-14, 1995, Vol. II, eds. G. J. Wagner, R. Bilger and T. Hehl.
- A. Marusi, *A new test of charge symmetry in eta production on deuterium*, Ph.D. dissertation, U. Of Zagreb, 1996.
- 891** *Lambda Production by 11.6 A GeV/c Au Beam on Au Target*, Physics Letters B (in print).
- Lambda Production in Au-Au Collisions at the AGS*, Abstracts submitted to the PANIC96 Conference.
- Lambda Production in Au-Au Collisions at the AGS*, Short write-up of parallel session talk presented at the PANIC96 Conference.
- 893** A. J. Keane, D. O'Sullivan, A. Thompson, L. O'C. Drury and K.-P. Wenzel, *The charge spectrum of ultra-heavy nuclei, including actinides, in the cosmic radiation*, Adv. Space Res., vol. 19, p. 739-742, 1997.
- A. J. Keane, *Measurement of the charge spectrum of ultra-heavy galactic cosmic rays with  $Z > 70$* , PhD Thesis, University College, Dublin, Natl. University of Ireland, 1997.
- A. J. Keane, A. Thompson, D. O'Sullivan, L. O'C. Drury and K.-P. Wenzel, *A charge spectrum of ultra-heavy cosmic ray nuclei, including actinides, detected on the LDEF*, Proc. 25th Intl. Cosmic Ray Conf., Durban, Vol 3, p. 361-364, 1997.
- 895** D. Best, et al., *First results on  $\Omega^-$  production between 2.8 A GeV*, from E895 proc. of strangeness in quark matter, Santorini, Greece, April 1997.
- H. Liu, et al., *Collective flow in Au + Au collisions in 2.8 GeV energy range*, proc. Of Nucleus-nucleus collisions, Gattingburg, TN, to appear Nuc. Phys. A (1997).
- 896** S. Costa, *Alla ricerca della particella  $H^0$  all' AGS di Brookhaven*, Proc. Of 81st Italian Physical Society, Perugia, Italy, Oct 2-7, 1995.
- S. Paganis, J. Hoffmann, P. Jensen, J. Schambach, J. Tang, R. Jensen, P. Riley, *BNL E896-I: Monte carlo simulations*, Abstract for Joint Spring Mtg of Texas Section of American Physical Society, Abilene, Texas, Mar. 15-16, 1996.

## Publications

---

- W. J. Llope, *The BNL-AGS Experiment 896*, Proc. 12th Winter Workshop Dynamics, Snowbird, Utah, W. G. Westfall, eds (Plenum Press, N.Y., N.Y.) Feb. 3-10, 1996.
- E. Judd, *The E896 Experiment - Search for the H-dibaryon*, Conf. Proc. AtHIPAGS'96, Detroit, Mich., Aug. 22-24, 1996, C. Pruneau, et al eds.
- 898** B. M. Sutherland, P. V. Bennet and J. C. Sutherland, *Quantitation of double strand breaks induced in human DNA by centigray doses of  $^{56}\text{Fe}$  (1 GeV/NUCLEON)*, Analytical Biochemistry 239, ; 53-60 (1996).
- C. Zeitlin, L. Heilborin and J. Miller, *Detailed characterization of the 1087 MeV/nucleon  $^{56}\text{Fe}$  beam used for*

*radiobiology at the AGS*, Rad. Res (1997) submitted.

M. Löbrich, B. Rydberg and P. K. Cooper, *Non random distribution of DNA double-strand breaks induced by particle irradiations*, Intl. Journal of Radiation Biology, Vol. 70, No. 5, p 493-503, 1996.

J. A. Joseph, S. Erat and B. M. Rabin, *CNS effects of heavy particle irradiation in space: behavioral implications*, Adv. Space. Res. (1997) in press.

M. Durante, K. George and T. C. Yang, *Biodosimetry of ionizing radiation by selective painting of prematurely condensed chromosomes in human lymphocytes*, Rad. Res. 148, S45-S50, 1997.

H. Wu, M. Durante, K. George and T. C. Yang, *Induction of chromosome aberrations in human cells by charged particles*, Rad. Res. 148, S102-107, 1997.

M. E. Vazquez, *Basic neurobiological problems in long-term deep space flights*, Adv. Space Res. (1997) in press.

**900** W. Hsi, et al., *Hadron-Induced Multifragmentation*, Proceedings of XIII Winter Workshop on Nuclear Dynamics, Marathon, FL, Feb. 1-8, 1997.

W. Hsi, et al., *Formation of Hot Nuclei with GeV D and B Beams*. Physical Review Letters, Vol 79, No. 5, p817, Aug 4, 1997.

V. E. Viola, et al., *Probing the nuclear EOS with GeV light ion beams*, to be published in Nucl. Phys. 1997.

K. Kwiatkowski, et al., *Light-ion-induced multifragmentation*, Proc. 35th Intl. Winter Mtg. On Nuclear Physics, Bormio, Italy, Feb. 1997, ed. I. Iori, p. 432.

K. Kwiatkowski, et al., *Multifragmentation: Thermal vs. Dynamic effects*, Proc. of 6th Intl. Conf. on Nucleus-Nucleus Collisions, June 2-6, 1997, Gatlinburg, TN; to be pub. In Nuclear Physics.

V. E. Viola, et al., *Heating the nuclear liquid with GeV hadrons*, Proc. of 8th Intl. Conf. On Nuclear Reaction Mechanisms, Varenna, Italy, June 9-14, 1997.

W. C. Hsi, et al., *Sideways-peaked angular distributions in hadron-induced multifragmentation: shock waves, toroids or kinematics?*, Indiana Report INC-40007-126 (1997).

**903** P. D. Panetta, J. E. Ostenson, D. K. Finnemore and C. L. Snead, Jr., *Pinning mechanisms in  $Y_1Ba_2Cu_3O_{7-x}$  single crystals*, Phys Rev. B1 52, 15, 570, 1995.

## Publications

---

**904** R. Weinstein, *Very high trapped fields: cracking, creep, and pinning centers*, invited paper, proc. Of 10th Anniversary HTS Workshop on Physics, Materials and Applications, Houston, TX, edited by W. K. Chu, D. Gubsner and K. A. Miller, World Scientific Press, p. 625, 1996.

R. Weinstein, *The pole of uranium with and without radiation, in the achievement of  $J_c \sim 10^5$  A/cm in large grain HTS*, invited paper, Proc. Of 1997 Workshop on Processing Superconducting (RE) BCO Large Grain materials, Cambridge, UK, July, 1997; Journal of Materials Science and Engineering B (in press).

**906** R. A. Krauss, et al.,  *$K^+$  Total Cross Sections on  $^{12}C$  and Medium Effects in Nuclei*, Phys. Rev. C46, 655-666 (1992)

P.H. File, et al., *A New 1-2 GeV/c Separated Beam for BNL*, Nuc. Instr. and Meth. in Physics Research A231, 48-58 (1992).

Jonas Alster, et al., *K<sup>+</sup> Nucleus Total Cross Section Experiment and Nuclear Medium Effects*, Nucl. Phys. A547 321c-330c (1992).

B.P. Quinn et al., *The Search for the H Dibaryon with the BNL 2.0 GeV/c Kaon Beam*, Invited Talk presented at the 4th Conf. on the Intersections between Particle and Nuclear Physics, May 24--29, 1991, Tucson, Arizona. AIP conference proceedings 243, p. 579-581 (1992).

P.D. Barnes, et al., *Search for the H Particle*, Nucl. Phys. A547 3c-16c (1992)

R. Sawafta, et al., *The K<sup>+</sup> Meson as a Probe of the Nuclear Medium*, Invited paper presented at the 4th Conf. on the Intersections between Particle and Nuclear Physics, May 24--29, 1991, Tucson, Arizona. AIP conf. proc. 243, p. 582-587 (1992).

R. Sawafta, et al., *The Influence of the Nuclear Medium on K<sup>+</sup> Total Cross Sections*, Phys. Lett. B307, 293 (1993).

G.E. Diebold, et al., *Production of pi<sup>+</sup>, K<sup>+</sup>, p, and pbar in Relativistic Au + Pt, Si + Pt and p + Pt Collisions at the AGS*, Phys. Rev. C48, 2984-2994 (1993).

B.P. Quinn, et al., *Search for the H Particle with the Brookhaven 2.0 GeV Kaon Beam*, Invited Talk Presented by B. Quinn at the Intl. Conf. on the Structure of Baryons and Related Mesons Workshop on Future Directions in Nuclear and Particle Physics at Multi-GeV Hadron Beam Facilities, March 4--6 (1993). BNL--52389, p. 340 (1993) held at Yale U., June 1--4, 1992, pub. by World Scientific and edited by M. Gai, p. 278-287.

G.B. Franklin, et al., *Strange Dibaryons*, Invited Talk Presented by G. Franklin at the Workshop on Future Directions in Nuclear and Particle Physics at Multi-GeV Hadron Beam Facilities, March 4--6 (1993). BNL--52389, p. 340 (1993).

M. Athanas, et al., *Search for the H Dibaryon by Xi<sup>-</sup> Capture on the Deuteron*, Proc. of the 13th Intl. Conf. on Particles and Nuclei held in Perugia, Italy, June 28--July 2, 1993, pub. by World Scientific and edited by Alessandro Pascolini, p. 652-655.

S.Ajimura, et al., *The Superconducting Kaon Spectrometer (SKS)*, Proc. of the 13th Intl. Conf. on Particles and Nuclei held in Perugia, Italy, June 28--July 2, 1993, pub. by World Scientific and edited by Alessandro Pascolini, p. 781-784.

## Publications

---

R. Sawafta, et al., *What Can Be Learned About Meson Nucleon Interactions and Nuclear Structure From K<sup>+</sup> Total Cross Sections*, Invited paper presented at the 5th Intl. Symposium on Meson--Nucleon Physics and the Structure of the Nucleon. Sept. 6--10 (1993), Boulder, Colorado, piN Newsletter No. 8, 74-79, 1993.

M. Athanas, et al., *Weak Decay of Light Hypernuclei*, Invited Talk by R.A. Schumacher at the JSPS-NSF Joint Seminar on "Hyperon Nucleon Interactions", Maui, HI, October, 1993.

R. Weiss, et al., *Measurement of Low Energy K<sup>+</sup> Total Cross Sections on N=Z Nuclei*, Phys. Rev. C49, 2569-2578 (1994).

N. Saito, et al., *Composite Particle Production in Relativistic Au + Pt, Si + Pt and p + Pt Collisions*, Phys. Rev. C49, 3211-3218 (1994).

E. Flaszky, et al., *The Measurements of Nuclear Medium Effects with  $K^+$* , Invited Talk Proc. of the Intl. Symposium on Medium Energy Physics, Beijing, China, August 1994.

T. Hasegawa, et al., *Core excited states of  $^{12}\text{C}$  hypernuclei formed in the  $(\pi^+, K^+)$  reaction*, Phys. Rev. Lett. 74, 224-227 (1995).

T. Fukuda, et al., *Superconducting Kaon Spectrometer (SKS)*, Nucl. Inst and Meth. A361 485-496 (1995).

B.P. Quinn, et al., *The Search for the  $H$  Dibaryon with the BNL 2.0 GeV/c Kaon Beam*, Proceedings of the 5th Conference on the Intersections between Particle and Nuclear Physics, May, 1994. AIP conference proc. 338, p. 520-525 (1995).

Reyad Sawaf, et al., *Do Narrow Sigma Hypernuclear States Exist?* Nucl. Phys. A585 103-108 (1995).

S. Ajimura, et al., *The Lambda Hypernuclear Spectroscopy with the SKS Spectrometer at 12 GEV PS*, Nucl. Phys. A585 173-182 (1995).

A. Rusek, et al., *Search for Strangelets and Other Rare Objects in Au + Pt Collisions at AGS Using a Fixed-Angle Focusing Spectrometer*, Nucl. Phys. A585 59-62 (1995).

B. Bassalleck, et al., *A Multi-cell Target for Double Lambda Hypernuclei Searches* Nucl. Phys. A585 339-340 (1995).

A. Rusek, et al., *Search for  $H$  dibaryon-nucleus bound states in relativistic Au+ Pt collisions*, Phys. Rev. C52, 1580 (1995).

T. Nagae, et al.,  *$(\pi^+, K^+)$  Spectroscopy with the SKS Spectrometer* Proc. of the 23rd Intl. Symposium on Nuclear and Particle Physics with Mesons Beams in the 1 GeV/c Region. Tokyo, March 1995.

T. Hasegawa et al., *Spectroscopic study of Lambda Hypernuclei,  $^{10}\text{B}$ ,  $^{12}\text{C}$ ,  $^{28}\text{Si}$ ,  $^{89}\text{Y}$ ,  $^{139}\text{La}$ , and  $^{208}\text{Pb}$  by the  $(\pi^+, K^+)$  reaction*, Accepted for publication in Phys. Rev. C, in press.

R. Michael et al.,  *$K^+$  Elastic Scattering from  $C$  and  $^6\text{Li}$  at 715 MeV/c*, Submitted for Publication in Phys. Rev. Lett.

## Publications

---

**907** M.W. Ahmed (for the E907 collaboration), *Characteristics of an active chamber target to locate the reaction vertex in the  $(K^-, \pi^0)$  reaction*, proc. of the conf. on Kaon and Hypernuclear Physics, BNL, 1997.

A. Rusek (for the E907 collaboration), *NMS studies of the  $(K^-, \pi^0)$  reaction*, proc. of the conf. on Kaon and Hypernuclear Physics, BNL, 1997.

**913** B. M. K. Nefkens,  *$N^*$  Physics at the AGS with the Crystal Ball Multiphoton Spectrometer*, Inst. For Nucl. Theory, Vol IV, T-S.H. Lee, W. Roberts eds., World Scientific, pg. 186, 1996.

W. J. Briscoe, *Meson production Experiments at TJNAL and BNL*, Inst. For Nucl. Theory, Vol. IV, T-S. H. Lee, W. Roberts, eds., World Scientific, pg. 306, 1996.

L.X. Jan, L. Addessi, V. Castillo, L.H. Gong, J. Leskowitz, R. Meier, G. Miglionico, J. Scaduto, *Safety Design, Operation, and Control of a Liquid Hydrogen Target at BNL*. Presented at 1997 Cryogenic Engineering Conf., Portland, Oregon, July 28-August 1, 1997.

W. B. Tippens, (for 913 collaboration), *Hadron spectroscopy with the crystal ball at the AGS*, Presented at Hadron 97, S.U. Chung, ed. (to be published) 1997.

A. Starostin, *Eta production in the reaction  $BP$  to  $ON$  near threshold*, Presented at Hadron 97, S.U. Chung, ed. (to be published) 1997.

W. B. Tippens, (for the 913 collaboration) *Recent results from the crystal ball program at BNL*, proc. Of GW/TJNAF Workshop on  $N^*$  Physics, Oct. 30 - Nov. 1, 1997 (to be published).

**916** Y. D. He, P. B. Price, and M. Solarz, *Charge-changing cross sections for gold projectile at  $\sim 4$  A GeV in various targets*, in preparation (1997).

**917** C. Ogilvie (for the E917 collaboration), *E917 collaboration: Probing the dynamics of HI collisions plus searching for the QGP*, Proc. Of HIPAGS 96, WSU-NP-96-16, C. A. Pruneau, ed., Detroit, Mich., 1996.

J. Chang (for the E917 collaboration), *Multiplicity measurements at various AGS beam energies*, Proc. 13th Winter Workshop on Nuclear dynamics, Marathon, Fla., 1997.

J. Dunlop (for the E917 collaboration) *An excitation function of particle production at the AGS*, Proc. Of 6th conf. On Intersections of Particle and Nuclear Physics, Big Sky, MT., 1997.

B. Back, et al., *A beam vertex detector using scintillating fibers*, Accepted for publication in Nuclear Instru. And Meth A, 1997.

C. Ogilvie (for the E917 collaboration), *E802/859/866/917 report*, proc. Of 13th Intl. Conf. On Ultra-Relativistic Nucleus-Nucleus Collisions, Tsukuba, Japan, 1997.

R. Set and J. Dunlop (for the E917 collaboration), *An excitation function at the AGS: Probing the dynamics of heavy ion collisions*, Proc. Of 13th Intl. Conf. On Ultra-Relativistic Nucleus-Nucleus collisions, Tsukuba, Japan, 1997.

## Publications

---

**923** M. V. Diwan, et al., *Search for  $T$ -violation in  $KM\bar{U}3$  decay*, presented by Hong Ma, Div. Of Particles and Fields, APS 1996 Divisional Mtg., Minneapolis, MN., Aug. 10-15, 1996.

**924** D. W. Hertzog, P. T. Debevec, R. A. Eisenstein, M. A. Graham, S. A. Hughes, P. E. Reimer, and R. L. Tayloe, *A High Resolution Lead/Scintillating Fiber Electromagnetic Calorimeter*, University of Illinois at Urbana-Champaign, Nuclear Physics Laboratory Department of Physics P/90/3/41.

*Large Solid Angle Detector for Charged Particles from Photodisintegration of Light Nuclei*, University of Illinois at Urbana-Champaign, Nuclear Physics Laboratory Department of Physics P/90/3/41.

**MPS** S. Eisman, et al., *The MPS II Drift Chamber System*. Nuclear Instruments and Methods 217, 140-148 (1983).



---

**A**

---

Abaev, V. V.	Petersburg Nuclear Physics Institute	924, 914, 913, 909, 890
Ables, E.	Lawrence Livermore National Laboratory	933
Aclander, H.	Tel-Aviv University	850
Adair, R.	Yale University	923
Adams, G.	Rensselaer Polytechnic Institute	852
Adams, T.	University of Notre Dame	852
Adler, S.	Brookhaven National Laboratory	787
Ahle, L.	Massachusetts Institute of Technology	866
Ahmad, S.	Rice University	891
Ahmed, M.	University of Houston	931, 929, 907
Ahrens, L.	Brookhaven National Laboratory	925, 880
Ajimura, S.	Osaka University	930, 929, 906
Ajitanand, N.	State University of New York-Stony Brook	895
Akchurin, N.	University of Iowa	925
Akekseev, I. G.	Institute for Theoretical and Experimental Physics-Moscow	925
Akiba, Y.	Institute for Nuclear Study-University of Tokyo	917, 866
Akikawa, S.	INS-University of Tokyo	906
Albergo, S.	University of Catania	896
Alburger, D.	Brookhaven National Laboratory	885
Alessi, J.	Brookhaven National Laboratory	925, 880
Alexander, J.	State University of New York-Stony Brook	895
Allgower, C.	Argonne National Laboratory	880
Alrick, K.	Los Alamos National Laboratory	939
Alster, J.	Tel-Aviv University	850
Amaglobeli, N.	HEP Inst. Tiblisi State University	865
Amann, J.	Los Alamos National Laboratory	933, 931, 907
Ambrose, D.	University of Texas at Austin	871
Androic, D.	University of Zagreb	931, 907
Ankenbrandt, C.	Fermi National Laboratory	932
Aoki, M.	KEK, National Laboratory for High Energy Physics	936, 787
Appel, R.	University of Pittsburgh	865
Arai, Y.	University of Tsukuba	936
Archambeau, J.	Loma Linda University	856
Ardebili, M.	Princeton University	787
Armendariz, J.	University of New Mexico	865
Armstrong, T.	Penn State University	864
Asano, Y.	University of Tsukuba	936
Ashktorab, K.	Brookhaven National Laboratory	866
Assamagan, K.	Hampton University	865
Atiya, M. S.	Brookhaven National Laboratory	787
Atoyan, G. S.	Inst. for Nuclear Reserach, Moscow	923, 865
Aufderheide, M. B.	Lawrence Livermore National Laboratory	933

---

**B**

---

Bachman, M.	University of California-Irvine	940, 935, 871
Back, B.	Argonne National Laboratory	917, 900

Bagaturia, Y.	HEP Inst. Tiblisi State University	865
Bagga, R.	Abilene Christian University	914, 913
Bai, M.	Argonne National Laboratory/Indiana University	925, 880
Baker, K.	Hampton University	865
Baker, M.	Massachusetts Institute of Technology	866
Balcer-Kubiczek, E.	University of Maryland Baltimore County	919
Balder-Kubiczek, E.K.	U. Of Maryland School of Medicine	898
Barakat, M.	Louisiana Tech University	931, 907
Barber, R.	University of Houston	929
Barbier, L. M.	Goddard Space Flight Center	934
Barcellos-Hoff, M. H.	Lawrence Berkeley Laboratory	898
Barish, K.	University of California-Los Angeles	941, 925, 864
Barkov, L. M.	Budker Inst. For Nuclearn Physics	821
Barnes, P.	Los Alamos National Laboratory	885, 813
Barnes Jr., P. D.	Lawrence Livermore National Laboratory	933
Barrette, J.	McGill University	877
Bart, S.	Brookhaven National Laboratory	909, 856
Barton, D. S.	Brookhaven National Laboratory	850
Bar-Yam, Z.	University of Massachusetts-Dartmouth	852
Bassalleck, B.	University of New Mexico	926, 906, 885, 865, 813
Bassano, D.	SUNY Health Science Center	856
Batiniġ, M.	Ruder Boskovic Institute	914, 913, 890
Batsouli, S.	Yale University	941
Baturin, V.	Pennsylvania State University	850
Bauer, G.	Paul Scherrer Institute	938
Bazanko, A.	Princeton University	787
Beatty, J. J.	Pennsylvania State University	934
Beavis, D.	Brookhaven National Laboratory	866
Bekrenev, V. S.	Petersburg Nuclear Physics Institute	924, 914, 913, 909, 890
Belikov, N. I.	Institute for High Energy Physics-Protvino	925
Belkacem, A.	Lawrence Berkeley Laboratory	892
Bellwied, R.	Wayne State University	896, 877, 864
Belzer, L. I.	Moscow State University	852
Benante, J.	Brookhaven National Laboratory	821
Bennhold, C.	George Washington University	924, 909
Bennett, B.	Wayne State University	864
Bennett, G.	Brookhaven National Laboratory	856, 821
Bennett, M.	Space Science Laboratory	896
Bennett, S.	Wayne State University	941
Berdoz, A.	Carnegie-Mellon University	906, 885, 813
Bergbusch, P.	TRIUMF	787
Bergman, D.	Yale University	865
Bersch, R.	SUNY at Stony Brook	877
Best, D.	Lawrence Berkeley National Laboratory	895
Betev, L.	University of California-Los Angeles	925
Betts, R.	University of Illinois-Chicago	917
Bharadwaj, V.	Fermilab	880
Biglan, A.	Carnegie-Mellon University	885
Binns, W. R.	Washington University in St. Louis	934, 869
Bionta, R. M.	Lawrence Livermore National Laboratory	933



Birchall, J.	University of Manitoba	906, 885
Bishop, J. M.	University of Notre Dame	852
Blackmore, E.	TRIUMF	926, 787
Blecher, M.	Virginia Polytechnic Institute	936, 926
Bodyagain, V. A.	Moscow State University	852
Boemi, D.	University of Catania	896
Bonner, B. E.	Rice University	896, 891
Borak, T.	Colorado State University	919
Boudrie, D.	Los Alamos National Laboratory	931, 907
Boudrie, R. L.	Los Alamos National Laboratory	933
Brabson, B. B.	Indiana University	852
Bracken, D. S.	Los Alamos National Laboratory	900
Brady, P.	University of California-Davis	895
Braun-Munzinger, P.	SUNY at Stony Brook	877
Breuer, H.	University of Maryland	900
Brennan, M.	Brookhaven National Laboratory	932
Brill, A. B.	University of Massachusetts	856
Briscoe, W.	George Washington University	931, 924, 914, 913, 909, 907, 905
Britt, H. C.	Lawrence Livermore Laboratory	866
Britt, H.	University of Maryland	917
Brooks, A.	Washington State University	919
Brown, C.	Carnegie-Mellon University	896
Brown, D. H.	Boston University	821
Brown, D. S.	Northwestern University	852
Brown, H. N.	Brookhaven National Laboratory	821
Brown, K.	Brookhaven National Laboratory	925, 880
Briscoe, W.	George Washington University	890
Buchnan, J. A.	Rice University	891
Budick, B.	New York University	866
Budny, T.	Wayne State University	877
Bullis, J.	Brookhaven National Laboratory	919
Bunce, G.	Brookhaven National Laboratory	925, 880, 850, 821
Burger, M.	Freiburg University	813
Bürger, T.	Freiburg University	885, 813
Bryman, D.	TRIUMF	926, 787

---

## C

---

Caccia, Z.	University of Catania	896
Cameron, P.	Brookhaven National Laboratory	925, 880
Canfield, P. C.	Ames Laboratory	903
Carabello, S.	Purdue University	940
Carey, R. M.	Boston University	821
Carman, D.	Carnegie-Mellon University	906, 885
Carpenter, J. M.	Argonne National Laboratory	938
Carroll, A. S.	Brookhaven National Laboratory	923, 850
Case, T.	Lawrence Berkeley National Laboratory	895
Caskey, W.	University of California-Davis	895
Cason, N. M.	University of Notre Dame	852

Cebra, D.	University of California-Davis	895
Chan, C. S.	City College of New York	891
Chance, J.	University of California-Davis	895
Chang, J.	University of California-Riverside	917, 866
Chang, W.	University of California-Riverside	917
Chapman, M.	KEK-National Laboratory for High Energy Physics	936, 813
Chasman, C.	Brookhaven National Laboratory	866
Chemakin, I.	Columbia University	910, 866
Chen, D. J.	Los Alamos National Laboratory	919, 898
Chen, Z.	Brookhaven National Laboratory	866
Cherry, M. L.	Louisiana State University	868
Chertovskikh, A.	Budker Inst. For Nuclear Physics	821
Chi, C. Y.	Columbia University	917, 866
Chiang, I-H.	Brookhaven National Laboratory	926, 787
Chikanian, A.	Yale University	941
Chrien, R. E.	Brookhaven National Laboratory	931, 930, 929, 909, 907, 906, 905, 890, 885, 856, 813
Christensen, N.	University of Auckland	850
Christian, E. R.	Goddard Space Flight Center	934
Chu, P.	Indiana University IUCF	880
Chu, Y. Y.	Brookhaven National Laboratory	917, 866
Chung, P.	State University of New York-Stony Brook	895
Chung, S. U.	Brookhaven National Laboratory	852
Cianciolo, V.	Lawrence Livermore National Laboratory	910
Cianciolo, V.	Massachusetts Institute of Technology	866
Cina, G.	University of Catania	896
Clajus, M. H.	University of California-Los Angeles	924, 914, 913, 909, 890
Clayton, N.	Lawrence Berkeley Laboratory	892
Cleland, W.	University of Pittsburgh	877
Clemen, M.	University of Pittsburgh	877
Clement, J. M.	Rice University	891
Coe, S.	Yale University	864
Cole, B.	Columbia University	910, 895, 866
Cole, J.	Idaho National Engineering Laboratory	877
Comfort, J. R.	Arizona State University	931, 914, 913, 907
Conner, C.	University of Illinois-Chicago	917
Connor, D.	University of California-Irvine	871
Conrad, H.	Forschungszentrum Jilich	938
Convery, M.	Princeton University	787
Cooper, P.	Lawrence Berkeley Laboratory	919, 898
Cormier, T.	Wayne State University	941, 877, 864
Costa, S.	University of Catania	896
Courant, E. D.	Brookhaven National Laboratory	880
Courant, H.	University of Minnesota	850
Cowan, T. E.	Lawrence Livermore National Laboratory	933
Cox, A.	USAF Armstrong Laboratory	919
Craig, K.	Arizona State University	914, 913
Crawford, H.	University of California-Space Science Laboratory	917, 896, 866
Cristie, W.	Brookhaven National Laboratory	896
Crittenden, R. R.	Indiana University	852

Cronqvist, M.	Space Science Laboratory	896
Crowe, K.	Lawrence Berkeley National Laboratory	895
Cui, X.	University of Houston	931, 907
Cullen, J.	Brookhaven National Laboratory	821
Culpepper, W. X.	National Aeronautics and Space Administration	922
Cumming, J. B.	Brookhaven National Laboratory	917, 866
Cummings, J. P.	Rensselaer Polytechnic Institute	852
Cushman, P.	University of Minnesota	821
Cverna, F.	Los Alamos National Laboratory	939

## D

---

Dai, Y.	McGill University	877
Dambrowska, A.	Institute of Nuclear Physics-Krakow	868
Danby, G. T.	Brookhaven National Laboratory	821
Danyo-Blackett, K.	Brookhaven National Laboratory	852
Das, A.	Ohio State University	895
DaSilva, N.	University of São Paulo	877
David, G.	Brookhaven National Laboratory	877
Davidenko, A. M.	Institute for High Energy Physics-Protvino	925
Davies, R. M.	Purdue University	864
Davis, C.	TRIUMF	885
Davis, C.	University of Manitoba	906, 813
Davis, C. L.	University of Louisville	852
Debbe, R.	Brookhaven National Laboratory	896, 866
Debevec, P.	University of Illinois	924, 821
DeCecco, P.	University of California-Irvine	896, 871
Dehnhard, D.	University of Minnesota	931, 907
Demytyev, D.	Institute for Nuclear Research-Moscow	926
Demianoi, A.	Moscow State University	852
Deng, H.	Yale University	821
Deninger, W.	University of Illinois	821
Denisov, S.	Institute for High Energy Physics-Protvino	852
Depommier, P.	University of Montreal	936
Derevshikov, A. A.	Institute for High Energy Physics-Protvino	925
Dhawan, S.	Yale University	926
Dhawan, S. K.	Yale University	865, 821
Diebold, G.	Yale University	813
Dienes-Jones, P.	Louisiana State University	868
Dietzsch, O.	University of São Paulo	877
Dinneen, T.	Lawrence Berkeley Laboratory	892
Diwan, M.	Brookhaven National Laboratory	923, 787
Djikibaev, R. M.	Institute for Nuclear Research	940
Do, H.	Yale University	865
Doornbos, J.	TRIUMF	885
Dorofeev, V. A.	Inst. For High Energy Physics - Protvino, Russia	852
Douvernoi, M.	Pennsylvania State University	934
Dowd, J.	University of Massachusetts-Dartmouth	852
Draper, B.	Abilene Christian University	914, 913
Draper, J.	University of California-Davis	895

Drigert, M.	Idaho National Engineering Laboratory	877
Druzhinin, V. P.	Budker Institute for Nuclear Physics	821
Dubinina, A. I.	Institute of Theory and Experimental Physics-Moscow	868
Dunlop, J.	Massachusetts Institute of Technology	917, 866
Duong, L.	University of Minnesota	821
Durant, S.	Tel-Aviv University	850
Dushkin, A.	Institute for High Energy Physics-Provino	852
Dzierba, A. R.	Indiana University	852

---

### E

Earle, W.	Boston University	821
Eckhause, M.	College of William and Mary	935, 924, 871
Ecklund, K.	Stanford University	871
Edwards, C.	Los Alamos National Laboratory	931, 907
Efendiev, A.	JNR-Dubna	914, 913, 909, 890
Efstathiadis, E.	Boston University	821
Efstathiadis, E.	City College of New York	891
Egger, J.	Paul Scherrer Institute	865
Egorov, O. K.	Institute of Theory and Experimental Physics-Moscow	868
Eilerts, S.	University of New Mexico	865
Eiseman, S. E.	Brookhaven National Laboratory	891
Elaasar, M.	Louisiana Tech. University	923
Eldredge, W.	University of California-Riverside	917, 866
Empl, A.	University of Houston	940, 931, 929, 907, 905
Endo, K.	KEK	821
Engelage, J.	Space Science Laboratory	917, 896, 866
Enyo, H.	University of Kyoto	813
Erin, S. V.	Institute for High Energy Physics-Provino	925
Etkin, A.	Brookhaven National Laboratory	891
Eugenio, P.	University of Massachusetts-Dartmouth	852
Evans, H.	Case Western Reserve University	919
Ewell, L.	Iowa State University	864

---

### F

Fachini, P.	Wayne State University	941
Fadem, B.	Iowa State University	941
Farley, F. J. M.	Yale University	821
Fedotovitch, G. V.	Budker Institute for Nuclear Physics	821
Feinberg, B.	Lawrence Berkeley Laboratory	892
Felder, C.	University of Pittsburgh	865
Fernow, R.	Brookhaven National Laboratory	910
Fickinger, W.	Case Western Reserve University	856
Finch, e.	Yale University	941
Finnemore, D. K.	Ames Laboratory	903
Fischer, H.	University of Freiburg	906, 885, 813

Fischer, H.	University of New Mexico	906, 865
Flores, M.	Space Science Laboratory	896
Foley, K. J.	Brookhaven National Laboratory	891
Foster, C. C.	Indiana University Cyclotron Facility	904
Frank, J. S.	Brookhaven National Laboratory	923, 787
Franklin, G. B.	Carnegie-Mellon University	931, 924, 907, 906, 885, 813
Franz, J.	University of Freiburg	906, 885, 813
Frawley, A. D.	Florida State University	910
Frehaut, J.	CEA	939
French, A.	Wayne State University	877
Fujino, D.	Lawrence Livermore National Laboratory	933
Fujiwara, T.	Kyoto University	926
Fukuda, T.	INS-University of Tokyo	930, 929, 906, 905
Fung, S.-Y.	University of California-Riverside	917, 866
Furic, M.	University of Zagreb	931, 907
Furusawa, Y.	Natl. Inst. of Radiological Sciences, Japan	919

## G

---

Gabriel, K.	Pennsylvania State University	850
Gan, L.	University of Manitoba	906, 885, 813
Gang, F.	Wayne State University	877
Ganz, R.	University of Illinois-Chicago	917
Garcia, E.	University of Maryland	917, 866
Gardner, C.	Brookhaven National Laboratory	821
Gardner, R.	Indiana University	852
Garrard, T. L.	Caltech	934, 869
Gasser, J.	University of Bern	865
Gatley, J.	Brookhaven National Laboratory	919
Gauland, C.	Arizona State University	931, 907
Geer, L. Y.	Washington University	869
Gelderloos, C. J.	University of Colorado	937
Geller, J.	Brookhaven National Laboratory	821
George N.	Yale University	941, 864
Gerald, J.	Brookhaven National Laboratory	931, 907
Ghazikhanian, V.	University of California-Los Angeles	925
Gibson, A.	Valparaiso University	914, 913
Gibson, B. F.	Los Alamos National Laboratory	931, 907
Giles, B.	University of Pittsburgh	865
Gilkes, M.	Purdue University	895
Gilkes, M.	State University of New York-Stony Brook	910
Gill, D.	TRIUMF	813
Gillitzer, A.	Argonne National Laboratory	917
Gimeno-Nogues, F.	Texas A&M University	900
Giron, S.	University of Minnesota	821
Glass, G.	University of Texas at Austin	931, 907
Glenn, J. W.	Brookhaven National Laboratory	926, 880
Gninenko, S. N.	Inst. for Nuclear Research, Academy of Sciences of Russia	865

Golubev, V. B.	Budker Inst. For Nuclear Physics	821
Goncharenko, Yu. M.	Institute for High Energy Physics-Provino	925
Gordeev, A.	Brookhaven National Laboratory	923
Goto, Y.	RIKEN	925
Gould, H.	Lawrence Berkeley Laboratory	892
Graessle, S.	University of Texas-Austin	871
Green, M. A.	Lawrence Berkeley Lab./Brookhaven National Laboratory	821
Greene, G.	Brookhaven National Laboratory	939
Greene, V. S.	Vanderbilt University	864
Greenwood, D.	Louisiana Tech. University	923
Greiner, L.	Space Science Laboratory	896
Greiner, L.	Lawrence Berkeley Laboratory	896
Grene, V.	Vanderbilt University	941
Gribushin, A. M.	Moscow State University	852
Grigoriev, D. N.	Budker Inst. For Nuclear Physics	821
Grosnick, D.	Valpariso University	924, 914, 913
Grosse-Perkekamp, M.	Yale University	821
Grossmann, A.	University of Heidelberg	821
Gumplinger, P.	TRIUMF	926
Gunter, J.	Indiana University	852
Guo, Y.	Wayne State University	896
Gupta, M.	Rice University	896
Gushue, S.	Brookhaven National Laboratory	910, 909, 900, 895, 866, 850

## H

---

Hackenburg, R. W.	Brookhaven National Laboratory	891, 871, 852
Haerberlen, U.	Max Planck Institut for Physik	821
Hafen, E. S.	Massachusetts Institute of Technology	864
Haggerty, J. S.	Brookhaven National Laboratory	787
Haines, J.	Oak Ridge National Laboratory	938
Hall, J.	Wayne State University	896, 877, 864
Hallman, T.	Brookhaven National Laboratory	896
Hamagaki, H.	Institute for Nuclear Study-University of Tokyo	917, 866
Hamilton, S.	University of Texas-Austin	871
Hanabata, M.	Gifu University	906
Hancock, D.	College of William and Mary	935, 871
Hanson, A. L.	Brookhaven National Laboratory	939
Hare, M.	Boston University	821
Haridas, P.	Massachusetts Institute of Technology	864
Hartman, C.	Stanford University	871
Hartouni, E. P.	Lawrence Livermore National Laboratory	933
Hashimoto, O.	Tohoku University	931, 930, 907
Hasinoff, M.	University of British Columbia - TRIUMF	936, 926
Hastings, J. B.	Brookhaven National Laboratory	938
Haversten, K.	Iowa State University	864
Hayakawa, H.	Osaka University	929
Hayano, R. S.	University of Tokyo	917, 905, 866
Hayashi, N.	RIKEN	925

Hayek, M.	University of Massachusetts-Dartmouth	852
Hazama, R.	Osaka University	929
Hazen, E. S.	Boston University	821
He, Y. D.	University of California-Berkeley	916, 903
Hebert, M.	Stanford University	871
Heffner, M.	University of California-Davis	895
Hei, T.K.	Columbia University	919, 898
Heintzelman, G.	Massachusetts Institute of Technology	917, 866
Hemnick, T. K.	SUNY at Stony Brook	877
Henning, W.	Argonne National Laboratory	917
Henry, G.	Lawrence Livermore National Laboratory	939
HeppeImann, S.	Pennsylvania State University	850
Herrmann, N.	GSI-Darmstadt	877
Hern, K.	College of William and Mary	935
Herold, W. D.	Paul Scherrer Institute	865
Hertzog, D. W.	University of Illinois	924, 821
Heijima, H.	Columbia University	910
Hill, J. C.	Iowa State University	941, 864
Hink, P. L.	Washington University in St. Louis	934
Hiramatsu, S.	KEK	880
Hirabayashi, H.	KEK	821
Hiroyoshi, Heijima	Columbia University	910
Hirsch, A. S.	Purdue University	864
Hirsh, A.	Purdue University	895
Hjort, E.	Purdue University	895
Hoff, C.	College of William and Mary	871
Hoffmann, G.	University of Texas	896, 871
Hofman, D.	Argonne National Laboratory	917
Hogan, G.	Los Alamos National Laboratory	933, 920
Holtzman, B.	University of Illinois-Chicago	917
Holynski, R.	Institute of Nuclear Physics-Krakow	868
Homma, S.	Institute for Nuclear Study-University of Tokyo	917, 866
Hong, B.	SUNY at Stony Brook	877
Hotchi, H.	INS - University of Tokyo	906
Hoversten, R.	Iowa State University	941
Hseuh, H-C.	Brookhaven National Laboratory	821
Hseuh, S.	Fermilab	880
Hsi, W.-Ch	Indiana University	900
Huang, H.	Brookhaven National Laboratory	925, 880
Huang, H.	University of California-Los Angeles	925, 896
Huang, H. Z.	University of California-Los Angeles	941, 864
Huddleston, J.	Abilene Christian University	914, 913
Hughes, B. J.	Boston University	821
Hughes, V.	Yale University	821
Humanic, T.	Ohio State University	896
Hungerford, E. V.	University of Houston	940, 931, 929, 907, 905
Huo, L.	Harbin University	895

---

**I**

---

Ibada, H.	High Energy Accelerator Research Org. (KEK)	938
Ichihara, T.	RIKEN	925
Ichii, S.	KEK	821
Ichikawa, A.	Kyoto University	885
Igo, G.	University of California-Los Angeles	925, 896
Iijima, T.	University of Kyoto	813
Iimina, T.	KEK	885
Ikeda, H.	KEK	938
Imai, K.	Kyoto University	906, 885, 813
Imazato, J.	KEK, National Laboratory for High Energy Physics	936
Inagaki, T.	KEK, National Laboratory for High Energy Physics	787
Ingrassia, P.	Brookhaven National Laboratory	880
Insolia, A.	University of Catania	896
Irwin, G. M.	Stanford University	871
Isenhower, L. D.	Abilene Christian University	914, 913, 909, 890
Ishida, K.	University of Riken	821
Ishikawa, T.	University of Tokyo	930, 917
Isreal, M. H.	Washington University in St. Louis	934
Issakov, V. V.	Inst. for Nuclear Reserach, Moscow	923, 865
Ito, M.	Thomas Jefferson National Accelerator Facility	926
Ito, M. M.	Princeton University	787
Ivanov, E. I.	University of Notre Dame	852
Ivashkin, A.	Institute for Nuclear Research-Moscow	926
Iwasaki, M.	Tokyo Inst. Of Technology	821

---

**J**

---

Jackson, J.	Brookhaven National Laboratory	821
Jain, V.	Brookhaven National Laboratory	926, 787
Jaradat, H.	Wayne State University	941
Jensen, P.	University of Texas	896
Jeon, D.	Indiana University IUCF	880
Ja, L.	Brookhaven National Laboratory	821
Johnson, S.	SUNY at Stony Brook	877
Johnston, K.	Louisiana Tech University	931, 923, 907
Johnston, K.	University of North Carolina	905
Johnstone, C.	Fermi National Laboratory	932
Jones, R. T.	University of Connecticut	924
Jones, W. V.	Louisiana State University	868
Jorgensen, T.	Georgetown University Medical Center	919, 898
Judd, E.	Space Science Laboratory	896, 866
Jungmann, K.	University of Heidelberg	821
Jurak, A.	Institute of Nuclear Physics-Krakow	868
Justice, M.	Kent State University	910, 895



**K**

Kabe, S.	KEK, National Laboratory for High Energy Physics	787
Kachae v, I. A.	Inst. For High Energy Physics - Protvino, Russia	852
Kagel, G.	University of California-Irvine	940, 935
Kainz, K.	Rice University	896
Kale, P.	Alabama Agr. And Mech. University	919
Kalogeropoulos, T.	Syracuse University	856
Kanavets, V. P.	Institute for Theoretical and Experimental Physics-Moscow	925
Kane, J.	College of William and Mary	935, 924, 871
Kaneko, H J.	Kyoto University	866
Kanematsu, N.	University of California-Irvine	871
Kang, J H.	Yonsei University	917, 910, 866
Kapinos, P.	TRIUMF	926, 787
Kaplan, M.	Carnegie-Mellon University	896, 895
Karavichev, O.	Inst. for Nuclear Research, Moscow	923
Karol, P.	Carnegie-Mellon University	896
Kaspar, H.	Yale University	926
Kaspar, H.	Paul Scherrer Institute	865
Kasprzyk, T.	Argonne National Laboratory	914, 913
Katayama, T.	RIKEN	880
Kawall, D.	Yale University	821
Kawamura, M.	Tokyo Inst of Technology	821
Kazumori, M.	INS - University of Tokyo	787
Keane, D.	Kent State University	910, 895
Kelly, S.	University of California-Los Angeles	896
Kern, B.	Indiana University	852
Kern, W.	University of Massachusetts-Dartmouth	852
Kettel, S.	Brookhaven National Laboratory	923, 787
Khaustov, P.	Carnegie-Mellon University	885
Khazin, B. I.	Budker Institute for Nuclear Physics	821
Khotjanzev, A.	Institute for Nuclear Research-Moscow	926
Kim, B.	Wayne State University	877
Kim, E. J.	Yonsei University	917, 866
Kindem, J.	University of Minnesota	821
King, E.	University of Massachusetts-Dartmouth	852
King, N. S. P.	Los Alamos National Laboratory	939, 933
Kinoshita, K.	Virginia Polytechnic Institute	926
Kinoshita, T.	Cornell University	821
Kirk, H.	Brookhaven National Laboratory	910
Kishi, Y.	Osaka University	787
Kishimoto, T.	Osaka University	930, 929, 906
Kitching, P.	TRIUMF	787
Klarmann, J.	Washington University	869
Knecht, N.	University of Regina	914, 913
Kobayashi, M.	KEK, National Laboratory for High Energy Physics	787
Kochetkov, V.	Institute for High Energy Physics-Protvino	852
Kodolva, O. L.	Moscow State University	852
Koehler, A.	Harvard Cyclotron Laboratory	856
Koetke, D. D.	Valparaiso University	924, 914, 913

Kolganova, E. D.	Institute of Theory and Experimental Physics-Moscow	868
Koltick, D.	Purdue University	940
Komatsubara, T.	National Laboratory for High Energy Physics (KEK)	787
Konaka, A.	TRIUMF	926, 787
Kondo, Y.	Kyoto University	885
Konismann, K.	University of Freiburg	906, 885
Koran, P.	Carnegie-Mellon University	906, 885
Korotkikh, V. L.	Moscow State University	852
Korteling, R.	Simon Fraser	900
Koslenko, N.	Petersburg Nuclear Physics Institute-Gatchina	914, 913
Kosonovsky, E.	Tel-Aviv University	850
Kostin, M. A.	Moscow State University	852
Kotov, I.	Ohio State University	896
Kozlenko, N. G.	Petersburg Nuclear Physics Institute	924, 909, 890
Kramer, M. A.	City College of New York	891
Kraus, D. E.	University of Pittsburgh	865
Kreisler, M.	Lawrence Livermore National Laboratory	910
Krienen F.	Boston University	821
Krofcheck, D.	University of Auckland	895
Kronenberg, A.	Lawrence Berkeley National Laboratory	919, 898
Kruger, K.	Argonne National Laboratory	880
Kruglov, S. P.	Petersburg Nuclear Physics Institute	924, 914, 913, 909, 890
Krueger, K.	Argonne National Laboratory	925
Kuang, Y.	College of William and Mary	935, 871
Kubota, K.	INS-University of Tokyo	906, 905
Kudenko, Y.	Institute for Nuclear Research-Moscow	926
Kudomi, N.	Osaka University	929
Kuhn, J.	Rensselaer Polytechnic Institute	852
Kulbardis, A.	Petersburg Nuclear Physics Inst-Gatchina	914, 913
Kumagai, A.	University of Tsukuba	866
Kumar, S.	Yale University	896
Kume, K.	Osaka University	929
Kuno, Y.	KEK, National Laboratory for High Energy Physics	787
Kuraev, E. A.	Budker Inst. For Nuclear Physics	821
Kurashige, H.	Kyoto University	926
Kurglov, N.	Moscow State University	852
Kuriki, M.	National Laboratory for High Energy Physics (KEK)	787
Kurita, K.	University of Tsukuba	910, 866
Kurokawa, S.	KEK	821
Kwiatkowski, K.	Indiana University	900
Kwon, Y.	SUNY at Stony Brook	877
Kwon, Y.	Yonsei University	917
Kycia, T. F.	Brookhaven National Laboratory	924, 914, 913, 787

## L

---

Lacasse, R.	McGill University	877
Lacey, R.	State University of New York-Stony Brook	895
Lahab, K.	Wayne State University	877

Lajoie, J.	Yale University	864
Lajoie, J.	Iowa State University	941
Lamble, W.	Indiana University, IUCF	880
Lan, A.	University of Houston	931, 929, 907
Lan, K. J.	University of Houston	940
Landry, M.	University of Manitoba	885, 813
Lang, K.	University of Texas-Austin	871
Laptev, S.	Inst. for Nuclear Research, Moscow	923
Larsen, R.	Brookhaven National Laboratory	821
Larsen, R.	Yale University	923
Lawrence, L.	Brookhaven National Laboratory	932
Lazarus, D.	Brookhaven National Laboratory	865, 926
Lebedev, V.	Inst. For Nuclear Research, Academy of Sciences of Russia	865
LeCompte, T.	Argonne National Laboratory	925
Lee, J. H.	Brookhaven National Laboratory	866
Lee, L.	University of Manitoba	929, 906, 885, 813
Lee, R.	University of California-Irvine	940, 935, 871
Lee, S. Y.	Indiana University	925, 880, 864
Lee, Y. Y.	Brookhaven National Laboratory	880, 821
LeFort, T.	Indiana University	900
Leipuner, L.	Brookhaven National Laboratory	865, 923
Leitch, M. H.	Los Alamos National Laboratory	890
Leksanov, A.	Pennsylvania State University	850
Leray, S.	LSN-CNRS	939
Leske, R. A.	Caltech	934
Lett, J.T.	Colorado State University	898
LeVine, M.	Brookhaven National Laboratory	866
Lewis, R. A.	Penn State University	864
Li, K. K.	Brookhaven National Laboratory	787
Li, Q.	Wayne State University	877
Libby, B.	Iowa State University	864
Liljestr�nd, R.	Bechtel Nevada	939, 933
Lindenbaum, S.	Brookhaven National Laboratory and City College of New York	891
Lindenbusch, R.	Indiana University	852
Lindgren, A. L.	Bemidji State University	898
Lindstrom, P.	Lawrence Berkeley Laboratory	896
LipaeV, V.	Institute for High Energy Physics-Protvino	852
Lisa, M.	Ohio State University	895
Littenberg, L. S.	Brookhaven National Laboratory	923, 787
Littenberg, L.	Brookhaven National Laboratory	926
Liu, H.	Kent State University	895
Liu, H.	University of California-Riverside	866
Liu, J.	University of Houston	904
Liu, T.	University of California-Irvine	940, 935
Liu, Y. M.	Harbin University	895
Ljubicic, T.	Brookhaven National Laboratory	896
Llope, W.	Rice University	896
Lobashev, V. M.	Institute for Nuclear Research	940
LoCurto, G.	Ohio State University	896
Logashenko, I.	Budker Inst. For Nuclear Physics	821

Lolos, G. J.	University of Regina	924, 914, 913
Long, H.	University of California at Los Angeles	941
Longacre, R. S.	Brookhaven National Laboratory	896, 891
Lopatin, I.	Petersburgh Nuclear Physics Institute	924, 914, 913
LoSecco, J. M.	University of Notre Dame	852
Love, W. A.	Brookhaven National Laboratory	896, 891
Lowe, J.	University of New Mexico	926, 906, 865
Lowe, J.	University of Birmingham	813
Lozano, J.	University Connecticut	865
Luccio, A.	Brookhaven National Laboratory	925, 880
Ludlam, T.	Brookhaven National Laboratory	877
Lutze-Mann, L. H.	University of California	919, 898
Lynn, D.	Brookhaven National Laboratory	896

## M

---

Ma, H.	Brookhaven National Laboratory	923, 865
Madansky, L.	Johns Hopkins University	896
Macdonald, J.	TRIUMF	936, 926, 787
Maeda, K.	Tohoku University	929
Magahiz, R.	Carnegie-Mellon University	885, 813
Maguire, C.	Vanderbilt University	941
Magurno, B.	Brookhaven National Laboratory	865
Majid, W.	Yale University	926, 865
Majka, R. D.	Yale University	941, 864
Makdisi, Y.	Brookhaven National Laboratory	925, 880, 850
Manak, J. J.	University of Notre Dame	852
Mane, V.	Brookhaven National Laboratory	932
Manglos, S.	SUNY Health Science Center	856
Manley, D. M.	Kent State University	924, 914, 913
Manweiler, R. W.	Valparaiso University	924, 914, 913
Marcin, M. R.	University of Texas-Austin	871
Mardor, I.	Tel-Aviv University	850
Mardor, Y.	Tel-Aviv University	850
Mariam, F.	Brookhaven National Laboratory	925, 880
Mariano, G.	Colorado State University	919
Mark, S. K.	McGill University	877
Marlow, D. R.	Princeton University	787
Marshak, M. L.	University of Minnesota	850
Martin, R. D.	College of William and Mary	871
Marušf, A.	Ruder Boskovic Institute /U. Calif-Los Angeles	924, 914, 913, 909, 890
Marx, J.	University of California-Berkeley	896, 891
Mashata, K.	KEK	821
Mathews, A. R.	Los Alamos National Laboratory	933
Matulenko, Yu. A.	Institute for High Energy Physics-Provino	925
May, M.	Brookhaven National Laboratory	931, 930, 929, 907, 906, 885
Mayer, C.	Carnegie-Mellon University	906
Mayes, B.	University of Houston	940, 931, 929, 907
Mazavia, D.	HEP Inst. Tbilisi State University	865

McCallum, R. W.	Ames Laboratory	903
McClellan, J. B.	Los Alamos National Laboratory	933
McCorkle, S.	Brookhaven National Laboratory	877
McCrary, R.	Carnegie-Mellon University	885, 813
McDonald, S.	University of California-Los Angeles	924, 914, 913, 909, 890
McDonough, J.	University of Texas-Austin	871
McGrath, R.	State University of New York-Stony Brook	910, 895
McKerley, M.	Indiana University	852
McLeod, D.	University of Illinois-Chicago	917
McNabb, R.	University of Minnesota	821
McPherson, R.	Princeton University	787
Meier, R.	Brookhaven National Laboratory	821
Meng, W.-Z.	Brookhaven National Laboratory	821
Menzel, W.	University of Basel	865
Merrill, F.	Los Alamos National Laboratory	885, 813
Merzliakov, Yu.	Budker Inst. for Nuclear Physics	821
Metting, N. F.	Pacific NW National Laboratory	919, 898
Mewaldt, R. A.	Caltech	934
Meyer, C.	Carnegie-Mellon University	924, 885, 813
Meyers, P. D.	Princeton University	787
Miake, Y.	University of Tsukuba	910, 866
Miachi, T.	INS-University of Tokyo	906
Mignerey, A.	University of Maryland	917, 866
Mildenberger, J.	TRIUMF	787
Milder, A.	University of Texas-Austin	871
Miller, D.	University of Minnesota	821
Miller, J.	Lawrence Berkeley National Laboratory	919, 898
Miller, J. P.	Boston University	924, 821
Miller, T.	Vanderbilt University	941
Milosevich, Z.	Carnegie-Mellon University	896, 895
Mincer, A.	New York University	940
Mineev, O.	Institute for Nuclear Research	926
Minor, E.	Pennsylvania State University	850
Mioduszewski, S.	University of Tennessee	910
Miskowicz, D.	SUNY at Stony Brook	877
Mitchell, J.	Brookhaven National Laboratory	896
Mitchell, J. W.	NASA-Goddard Space Flight Center	934, 896
Miyachi, T.	INS-University of Tokyo	905
Miyajima, M.	Fukui University	787
Mizumachi, Y.	Science University of Tokyo	821
Mizuno, Y.	Osaka University	929
Mogavero, E.	Brookhaven National Laboratory	896
Molzon, W.	University of California-Irvine	940, 935, 871
Moore, C. F.	University of Texas at Austin	931, 907
Morgan, G. L.	Los Alamos National Laboratory	939
Morgan, W.	University of California	919
Mori, Y.	KEK	880
Morikubo, K.	Osaka University	929
Morimoto, T.	KEK	787
Moriwaki, T.	University of California-Los Angeles	914, 913, 909, 890

Morley, K. B.	Los Alamos National Laboratory	933, 920, 900
Morris, C.	Los Alamos National Laboratory	933, 931, 920, 907
Morrison, D.	University of Tennessee	910
Morrison, T.	George Washington University	914, 913, 909, 890
Morse, W. M.	Brookhaven National Laboratory	821
Moskowitz, B.	Brookhaven National Laboratory	866
Mottershead, C. T.	Los Alamos National Laboratory	933
Moulson, M.	Columbia University	910, 866
Mueller, K.	Los Alamos National Laboratory	933, 920
Muentz, C.	Brookhaven National Laboratory	866
Muerleilier, M.	University of Houston	929
Mulkey, Z.	Abilene Christian University	914, 913
Munhoz, M.	Wayne State University	941
Muramatsu, N.	INS-University of Tokyo	787
Mutchler, G. S.	Rice University	896, 891
Myuchi, T.	INS-University of Tokyo	906

---

## N

---

Nagae, T.	INS-University of Tokyo	930, 929, 906, 905
Nagamaya, S.	Columbia University	866
Nagle, J.	Columbia University	941
Nagle, J.	Yale University	864
Naing, W.	Hampton University	905
Nakada, Y.	RIKEN	925
Nakai, K.	Science University of Tokyo	936
Nakano, T.	Osaka University	929, 906, 905, 787
Namboodiri, M. N.	Lawrence Livermore National Laboratory	910, 866
Nanal, V.	Argonne National Laboratory	917
Napolitano, J.	Rensselaer Polytechnic Institute	852
Natarajan, M.	University of Texas	919
Navon, I.	Tel-Aviv University	850
Nazakawa, K.	Gifu University	906
Neerman, C.	University of North Carolina	905
Nefkens, B.	University of California-Los Angeles	931, 924, 914, 913, 909, 907, 890
Nehmeh, S.	Wayne State University	896
Nelson, G.	Loma Linda University	919
Nelson, G. A.	Jet Propulsion Laboratory	898
Nelson, J.	University of Birmingham	813
Nemethy, P.	New York University	940
Ng, B.	Fermi National Laboratory	932
Ng, C. F.	Brookhaven National Laboratory	787
Nicholson, H.	Mt Holyoke College	850
Nilsen, B. S.	University of Minnesota	869
Nogach, L. V.	Institute for High Energy Physics-Provino	925
Nomachi, M.	Osaka University	929
Nord, P.	Valparaiso University	914, 913
Norem, J. H.	Argonne National Laboratory	932
Norman, A.	College of William and Mary	935

Norm and, L.	McGill University	877
Noumi, H.	KEK	930, 929
Nozar, M.	Rensselaer Polytechnic Institute	852
Numao, T.	TRIUMF	926, 787
Nurushev, S. B.	Institute for High Energy Physics-Protvino	925

---

**O**

---

Obot, V.	Texas Southern University	904
O'Brien, E.	Brookhaven National Laboratory	877
O'Donnell, J.	Los Alamos National Laboratory	931, 907
Odyniec, G.	Lawrence Berkeley National Laboratory	895
Ogawa, A.	Pennsylvania State University	850
Ogilvie, C.	Massachusetts Institute of Technology	917, 866
Okada, K.	Kyoto-Sangyo University	906, 813
Okomura, M.	RIKEN	925, 880
Okumoto, H.	National Laboratory for High Energy Physics (KEK)	787
Olchanski, K.	Brookhaven National Laboratory	852
O'Leary, J.	Brookhaven National Laboratory	866
O'Leary, D.	Lawrence Berkeley National Laboratory	895
Olszewski, A.	Institute of Nuclear Physics-Krakow	868
Omata, K.	INS-University of Tokyo	906
Orlov, Y.	Cornell University	821
Ormes, J. F.	Goddard Space Flight Center	934
Ostrovidov, A. I.	Moscow State University	852
Otomo, A.	National Laboratory for High Energy Physics (KEK)	787
Ota, H.	INS-University of Tokyo	930, 929, 906, 905
Overlin, M.	University of California at Irvine	940
Oyama, K.	University of Tokyo	917

---

**P**

---

Padley, P.	TRIUMF	787
Paganis, S.	University of Texas	896
Page, S.	University of Manitoba	906, 856, 813
Pai, C.	Brookhaven National Laboratory	821
Pak, R.	University of Rochester	917
Pandey, S.	Wayne State University	896
Panebratsev, Y.	J.I.N.R.-Dubna	850
Panitkin, S.	SUNY at Stony Brook	877
Panitkin, S.	Kent State University	895
Papandreou, Z.	George Washington University	924, 914, 913, 909, 890
Park, H.-S.	Lawrence Livermore National Laboratory	933
Parks, D.	University of Houston	904
Paschke, K.	Carnegie-Mellon University	906, 885
Patterson, J.	University of Colorado	914, 913
Paul, P.	SUNY at Stony Brook	877
Pavlinov, A. I.	Institute for High Energy Physics-Protvino	925
Peaslee, D.	University of Maryland	924

Pedlar, T.	Northwestern University	852
Peng, J.C.	Los Alamos National Laboratory	931, 907, 890
Perepechkin, Y.	INR - Russia	906
Peterson, G. A.	University of Colorado	931, 937, 924, 907
Peterson, J.	University of Colorado	914, 913
Peterson, R. J.	University of Colorado	937
Petkovic, T.	University of Zagreb	931, 907
Petridis, A.	Iowa State University	941
Phillips, S.	George Washington University	909
Piasezky, E.	Tel-Aviv University	850
Piazza, T.	SUNY at Stony Brook	877
Pienkowski, L.	Warsaw University	900
Pile, P. H.	Brookhaven National Laboratory	931, 930, 929, 924, 907, 906, 885, 813
Pinkenburg, C.	State University of New York-Stony Brook	895
Pinsky, L.	University of Houston	940, 931, 929, 907
Pislak, S.	University of Zurich	865
Pitt, M.	Virginia Polytechnic Institute	926
Planinic, M.	University of Zagreb	931, 907, 905
Platner, E. D.	Rice University	896, 891
Pless, I.	Massachusetts Institute of Technology	941, 864
Poblaguev, A. A.	Inst. For Nuclear Research, Academy of Sciences of Russia	865
Polk, I.	Brookhaven National Laboratory	821
Polly, C.	University of Illinois	821
Polychronakas, V.	Brookhaven National Laboratory	923
Pommet-Maia, M.	Stanford University	871
Pope, J. K.	Yale University	864
Poplaguev, A.	Inst. for Nuclear Research, Moscow	923
Popov, A. V.	Inst. For High Energy Physics, Protvino, Russia	852
Popovic, M.	Fermi National Laboratory	932
Porile, N. T.	Purdue University	895, 864
Postoev, V.	Inst. For Nuclear Research, Academy of Sciences of Russia	865
Potenza, R.	University of Catania	896
Poutissou, J.M.	TRIUMF	787
Poutissou, R.	TRIUMF	787, 926
Pozharova, E. A.	Institute of Theory and Experimental Physics-Moscow	868
Prasad, S. C.	SUNY Health Science Center	856
Pratt, R.	George Washington University	909
Price, J. W.	University of California-Los Angeles	890
Price, P. B.	University of California-Berkeley	916
Prigl, R.	Brookhaven National Laboratory	821
Prohvatilov, M.	INR-Russia	906
Prokop, J.	George Washington University	909
Proskuryakov, A.	Moscow State University	923, 852, 865
Pruneau, C.	Wayne State University	941, 877, 864
Pulver, M.	University of California-Los Angeles	914, 913

---

## Q

Qian, Z.	Fermi National Laboratory	932
Quinn, B.	Carnegie-Mellon University	931, 924, 907, 906, 885, 813



**R**

Rabin, B.	University of Maryland Baltimore County	919, 898
Rabin, M. S. Z.	University of Massachusetts	941, 864
Rai, G.	Lawrence Berkeley National Laboratory	910, 895
Ramakrishnan, E.	Texas A&M University	900
Ramirez, A.	Arizona State University	914, 913
Ramsay, D.	University of Manitoba	885, 813
Ramsey, W. D.	University of Manitoba	906
Rangacharyulu, C.	University of Saskatchewan	936
Rankowitz, S.	Brookhaven National Laboratory	821
Ransom, R.	Rutgers University	885
Rasin, V.	INR-Russia	906
Ratner, L.	Brookhaven National Laboratory	925, 880
Read, K.	University of Tennessee	910
Reber, E.	Idaho National Engineering Laboratory	877
Redin S. I.	Yale University	821
Redlinger, G.	TRIUMF	787
Reece, K.	Brookhaven National Laboratory	880
Reed, J.	Syracuse University	856
Rehak, P.	Brookhaven National Laboratory	865
Reid, J.	Vanderbilt University	864
Reiley, P.	University of Texas	941, 896
Reimer, P. E.	University of Illinois-Urbana-Champaign	924
Relyea, D. R.	Princeton University	787
Remsberg, L. P.	Brookhaven National Laboratory	910, 909, 900, 866
Ren, Y.	University of Houston	904
Reshetin, A.	INR - Russia	906
Riley, P. J.	University of Texas-Austin	871
Rind, O.	Boston University	821
Ritchie, J. L.	University of Texas-Austin	871
Ritter, H. G.	Lawrence Berkeley National Laboratory	895
Ritter, J.	University of Illinois-Urbana-Champaign	924
Roberts, B. L.	Boston University	821
Robinson, D. K.	Case Western Reserve University	856
Robmann, P.	University of Zurich	865
Romero, J.	University of California-Davis	895
Roos, P. G.	University of Maryland	931, 907
Rosati, M.	Brookhaven National Laboratory	910, 877
Rose, A.	Vanderbilt University	941
Roser, T.	Brookhaven National Laboratory	932, 925, 880, 850
Rössle, R.	Freiburg University	813
Rotondo, F. S.	Yale University	896, 864
Rowland, D.	Texas A&M University	900
Roy, J.	TRIUMF	787
Rozon, M.	TRIUMF	787
Rozon, M.	University of Alberta	813
Ruangma, A.	University of Maryland	917
Rubin, P.	University of Richmond	935, 871

Rusek, A.	Brookhaven National Laboratory	931, 930, 907, 906, 905, 885
Rusek, A.	University of New Mexico	813
Russ, D.	University of Maryland	917
Russell, G.	Los Alamos National Laboratory	938
Russell, J. J.	University of Massachusetts-Dartmouth	850
Russo, G.	University of Catania	896
Rusek, A.	Brookhaven National Laboratory	929
Rust, D. R.	Indiana University	852
Ryabchikov, D. I.	Inst. For High Energy Physics, Protvino, Russia	852
Ryan, J.	Massachusetts Institute of Technology	866
Ryskulov, N.	Budker Institute for Nuclear Physics	821

---

### S

---

Sachelashvili, T.	HEP Inst. Tbilisi State University	865
Sadler, M.	Abilene Christian University	914, 913, 909, 890
Saito, N.	University of Kyoto	813
Saito, N.	RIKEN	925
Sajai, E.	Osaka University	929
Sakai, H.	University of Tokyo	925
Sakamoto, S.	KEK	821
Sakitt, M.	Brookhaven National Laboratory	856
Sako, H.	Institute for Nuclear Study-University of Tokyo	866
Sakrejda, I.	Lawrence Berkeley Laboratory	896
Sandberg, J.	Brookhaven National Laboratory	821
Sanders, R.	Brookhaven National Laboratory	821
Sandweiss, J.	Yale University	941, 864
Sangster, T. C.	Lawrence Livermore National Laboratory	910, 866
Sanjari, A.	University of Notre Dame	852
Sarracino, J.	Los Alamos National Laboratory	933, 920
Sarycheva, L. I.	Moscow State University	852
Sasao, N.	Kyoto University	926
Sasaki, T.	Osaka University	787
Sato, R.	Osaka University	929
Sato, S.	University of Tsukuba	866
Sato, T.	KEK, National Laboratory for High Energy Physics	880, 821, 787
Saulys, A.	Brookhaven National Laboratory	896, 891
Sawafra, R.	North Carolina A&T University	931, 930, 929, 909, 907, 906, 905, 885
Sawafra, R.	Brookhaven National Laboratory	906, 890, 885, 856, 813
Sawh, R-P.	University of Houston	904
Schambach, J.	University of Texas	896
Scharenberg, R. P.	Purdue University	895, 864
Schindler, S. M.	Caltech	934
Schmidt, H.	Freiburg University	885, 813
Schmitt, H.	University of Freiburg	906
Schroeder, L.	University of California-Berkeley	891
Schroeder, L.	Lawrence Berkeley National Laboratory	895
Schumacher, R. A.	Carnegie-Mellon University	924, 906, 885, 813
Scott, E.	Indiana University	852

Sculli, J.	New York University	940
Sedykh, S.	University of Illinois	924, 821
Semertzidis, Y.	Brookhaven National Laboratory	821
Sengupta, K.	Louisiana State University	868
Sekimoto, M.	INS-University of Tokyo	906
Serednyakov, S.	Budker Institute for Nuclear Physics	821
Seth, K.	Northwestern University	924, 852
Seto, R.	University of California-Riverside	917, 866
Seyfarth, H.	Forschungszentrum Jilich	890
Shafi, A.	George Washington University	914, 913
Shatunov, Yu. M.	Budker Institute for Nuclear Physics	821
Shea, J.	University of Maryland	866
Sheen, J.	Wayne State University	896, 877
Shein, I.	Institute for High Energy Physics-Provino	852
Shephard, W. D.	University of Notre Dame	852
Shileev, K.	INR - Russia	906
Shimanskiy, S.	J.I.N.R. - Dubna	850
Shimizu, Y.	University of Tokyo	906, 905
Shin, B.	University of Saskatchewan	936
Shin, Y. H.	Yonsei University	910
Shinkawa, T.	KEK, National Laboratory for High Energy Physics	787
Shivakumar, B.	Yale University	864
Shoemaker, F. C.	Princeton University	787
Shutt, R.	Brookhaven National Laboratory	821
Sinev, N. B.	Moscow State University	852
Skank, H.	Ames Laboratory	941, 864
Skelly, J. E.	Brookhaven National Laboratory	880
Skorotko, T. Yu.	Institute of Theory and Experimental Physics-Moscow	868
Slaughter, A. J.	Yale University	941, 864
Slaughter, D.	Lawrence Livermore National Laboratory	939
Šlaus, I.	Ruder Boskovic Institute	914, 913, 909, 890
Sleege, G.	Ames Laboratory	941, 864
Smirnitski, V. A.	Institute of Theory and Experimental Physics-Moscow	868
Smirnoff, N.	Yale University	896
Smith, A. J. S.	Princeton University	787
Smith, G.	TRIUMF	926
Smith, G. A.	Penn State University	864
Smith, J.	Rensselaer Polytechnic Institute	852
Smith, P. T.	Indiana University	852
Snead, C. L.	Brookhaven National Laboratory	939, 903
Snydstrup, L.	Brookhaven National Laboratory	821
Sobolewski, Z.	Syracuse University	856
Soldatov, A.	Institute for High Energy Physics-Provino	852
Solodov, E.	Budker Institute for Nuclear Physics	821
Soltz, R.	Lawrence Livermore National Laboratory	933, 910, 866
Soluk, R.	TRIUMF	787
Sonderegger, P.	CERN	896
Sonnadara, U.	University of Pittsburgh	877
Sorensen, S.	University of Tennessee	910
Soukas, A.	Brookhaven National Laboratory	880, 821

Spine lli, P.	University of Bari	864
Spinka, H.	Argonne National Laboratory	925, 914, 913, 880
Srivastava, B. K.	Purdue University	895, 864
Stachel, J.	SUNY at Stony Brook	877
Stanislaus, S.	Valparaiso University	924, 914, 913
Stankas, J.	University of Maryland	917
Starinsky, N.	McGill University	877
Starostin, A.	Petersburg Nuclear Physics Institute	924, 914, 913, 890
Staudenmaier, H. M.	University of Karlsruhe	924, 914, 913
Steadman, S. G.	Massachusetts Institute of Technology	866
Stearns, R.	Vassar College	813
Stephans, G. S. F.	Massachusetts Institute of Technology	917, 866
Stevens, A. J.	Brookhaven National Laboratory	787
Stenike, D. L.	University of Notre Dame	852
Stillman, A.	Brookhaven National Laboratory	821
Stokely, C.	Rice University	896
Stone, E. C.	Caltech	869
Stone, N.	Lawrence Berkeley National Laboratory	895
Stone, J. R.	Princeton University	787
Stotzer, R.	University of New Mexico	885, 865, 813
Strand, R. C.	Brookhaven National Laboratory	926, 787
Streitmatter, R. E.	Goddard Space Flight Center	934
Stringfellow, B. C.	Purdue University	864
Suda, T.	Tohoku University	929
Sugarbaker, E.	Ohio State University	896
Sugimoto, S.	INS-University of Tokyo	787
Sukatun, R.	Carnegie-Mellon University	813
Sulak, L. R.	Boston University	821
Sulanke, T.	Indiana University	852
Sum, V.	University of Manitoba	885, 813
Supek, I.	R. Boskovic Institute	931, 914, 913, 907
Sutherland, B. M.	Brookhaven National Laboratory	919, 898
Sutter, R.	Brookhaven National Laboratory	931, 929, 909, 907, 906, 905, 890, 885, 856, 813
Sutton, C. S.	Mt. Holyoke College	850
Švarc, A.	Ruder Boskovic Institute	914, 913, 890
Svirida, D. N.	Inst. for Theoretical and Experimental Physics-Moscow	925
Symons, J.	Lawrence Berkeley National Laboratory	895
Syphers, M.	Brookhaven National Laboratory	925, 880
Szarska, M.	Institute of Nuclear Physics-Krakow	868
Szymanski, J.	Indiana University Cyclotron Facility	813

## T

---

Taeger, S. A.	University of Notre Dame	852
Takagui, M.	University of São Paulo	877
Takahashi, J.	Wayne State University	896
Takehashi, T.	Tohoku University	930

Takeutchi, F.	Kyoto-Sangyo University	906, 885, 813
Tallerico, T.	Brookhaven National Laboratory	821
Tamagawa, T.	INS-University of Tokyo	929, 906, 905
Tamagawa, Y.	Fukui University	787
Tamura, H.	INS-University of Tokyo	930, 929, 917, 906, 905
Tamura, K.	Osaka University	929
Tanaka, M.	Brookhaven National Laboratory	850
Tang, J.	University of Texas	896
Tang, L.	CEBAF	931, 907
Tang, L.	Hampton University	930, 929
Tanida, K.	INS-University of Tokyo	930, 906
Tannenbaum, M. J.	Brookhaven National Laboratory	866
Teige, S.	Indiana University	852
Teng, L.	Argonne National Laboratory	880
Tepikian, S.	Brookhaven National Laboratory	880
Themann, H.	Rice University	896
Thern, R. E.	Brookhaven National Laboratory	880
Thiessen, A.	Los Alamos National Laboratory	931, 907
Thomas, J.	Lawrence Livermore National Laboratory	910, 866
Thompson, A.	Dublin Inst. For Advanced Studies	893
Thompson, D. R.	University of Notre Dame	852
Thompson, J.A.	University of Pittsburgh	865
Thompson, P.	Brookhaven National Laboratory	821
Thompson, R.	Bechtel Nevada	939, 933
Throwe, T. G.	Brookhaven National Laboratory	864
Timmermans, C.	University of Minnesota	821
Tincknell, M. L.	Purdue University	864
Tippens, W. B.	Brookhaven National Laboratory	931, 907
Tippens, W. B.	University of California-Los Angeles	924, 914, 913, 909, 890
Todosow, M.	Brookhaven National Laboratory	939
Toldo, F.	Brookhaven National Laboratory	821
Tomiyama, T.	RIKEN	880
Toropin, A. N.	Institute for Nuclear Research	940
Torun, Y.	Brookhaven National Laboratory	910
Trbojevic, D.	Brookhaven National Laboratory	932
Trentalage, S.	University of California-Los Angeles	925, 896
Tricomia, A.	University of Catania	896
Trofimov, A.	Boston University	821
Truol, P.	University of Zurich	865
Trzaska, M.	SUNY at Stony Brook	877
Trzupsek, A.	Institute of Nuclear Physics-Krakow	868
Tsalov, D.	Pennsylvania State University	850
Tsoupas, N.	Brookhaven National Laboratory	925, 880
Tsvetkov, I. O.	J.I.N.R., Dubna	850
Turcot, A. S.	TRIUMF	787

---

**U**

---

Ufim tsev, A.	Institute for High Energy Physics-Serpukhov	880
Ukai, K.	INS-University of Tokyo	787
Ullmann, J.	Los Alamos National Laboratory	939
Underwood, D.	Argonne National Laboratory	925, 880
Urner, D.	University of Illinois	924, 821

---

**V**

---

van Asselt, W.	Brookhaven National Laboratory	880
VanBibber, K. A.	Lawrence Livermore National Laboratory	933
Van Buren, G.	Massachusetts Institute of Technology	941, 864
van Oers, W.	University of Manitoba	906, 885, 813
Vardanyan, I. N.	Moscow State University	852
Vasiliev, A. N.	Institute for High Energy Physics-Protvino	925
Vazquez, M.	Brookhaven National Laboratory	919, 898
Videbaek, F.	Brookhaven National Laboratory	866
Viola, V. E.	Indiana University	900
Visser, G.	Space Science Laboratory	896
Voloshin, S.	University of Pittsburgh	877
von Walter, P.	University of Heidelberg	821
Vongpaseuth, T.	SUNY at Stony Brook	877

---

**W**

---

Waddington, C. J.	University of Minnesota	934, 869, 868
Wakasa, T.	University of Tokyo	925
Waldren C.	Colorado State University	919, 898
Wales, W. D.	University of Pennsylvania	940
Wang, F.	Columbia University	866
Wang, H.	University of California-Riverside	917
Wang, S.	Kent State University	895
Wang, Y.	Columbia University	866
Watanabe, N.	Japan Atomic Energy Research Institute	938
Ward, H.	University of Texas-Austin	931, 907
Ward, T.	U. S. Department of Energy	939
Ware, C. B.	University of Texas-Austin	871
Watanabe, N.	Japan Atomic Energy Research Institute	838
Waters, L.	Los Alamos National Laboratory	939
Wefel, J. P.	Louisiana State University	868
Weinstein, R.	University of Houston	904

Wells, R.	Ohio State University	895
Welsh, R.	University of Michigan	896
Welsh, R.	College of William and Mary	935, 924, 871
Wessels, J.	SUNY at Stony Brook	877
Westphal, A.	University of California-Berkeley	915
Weyer, H.	Paul Scherrer Institute	865
Weygand, D. P.	Brookhaven National Laboratory	852
Wieder, M.	Freiburg University	813
White, D.	Rensselaer Polytechnic Institute	852
White, D. B.	University of California-Los Angeles	914, 913, 909, 890
Whitfield, J.	Carnegie-Mellon University	896, 895
Whitten, C.	University of California-Los Angeles	925
Whohn, F.	Iowa State University	941
Widenbeck, M. E.	Caltech	934
Wienands, U.	TRIUMF	880
Wienold, T.	Lawrence Berkeley National Laboratory	895
Wilczynska, B.	Institute of Nuclear Physics-Krakow	868
Wilczynski, H.	Institute of Nuclear Physics-Krakow	868
Williams, N.	Brookhaven National Laboratory	880
Willutzki, H. J.	Brookhaven National Laboratory	852
Wilson, J.	University of Houston	940
Wilson, K.	Wayne State University	896
Winn, D.	Fairfield University	821
Winter, D.	Columbia University	910
Wise, J.	Northwestern University	852
Witkowski, M.	Rensselaer Polytechnic Institute	935, 852
Witt, R.	Kent State University	895
Witzig, C.	Brookhaven National Laboratory	787
Wohn, F. K.	Iowa State University	864
Wojcicki, S. G.	Stanford University	871
Wolfe, M.	University of New Mexico	906, 865, 813
Wolfs, F.	University of Rochester	917
Wolin, E.	College of William and Mary	871
Wolter, W.	Institute of Nuclear Physics-Krakow	868
Woodruff, D.	Massachusetts Institute of Technology	866
Woody, C.	Brookhaven National Laboratory	926, 871
Worm, S.	University of Texas-Austin	871
Worstell, W.	Boston University	821
Wosiek, B.	Institute of Nuclear Physics-Krakow	868
Wozniak, K.	Institute of Nuclear Physics-Krakow	868
Wright, A.	Rensselaer Polytechnic Institute	852
Wright, D. M.	Lawrence Livermore National Laboratory	933
Wu, J. Y.	Pennsylvania State University	850
Wu, Y.	Columbia University	866
Wuosmaa, A.	Argonne National Laboratory	917

---

**X**

---

Xiang, H.	University of California-Riverside	917, 866
Xiong, H.	Wayne State University	877
Xu, G.	University of California-Riverside	917
Xu, Q.	University of California -Riverside	866
Xu, Z.	Yale University	941

---

**Y**

---

Yagi, K.	University of Tsukuba	866
Yamamoto, A.	National Laboratory for High Energy Physics (KEK)	821
Yamamoto, E.	University of California at Los Angeles	941
Yamamoto, K.	Kyoto University	906, 885
Yang, X.	Columbia University	910, 866
Yang, T. C-H.	NASA Johnson Space Center	919, 898
Yao, H.	Massachusetts Institute of Technology	917, 866
Yates, G. J.	Los Alamos National Laboratory	933
Yennello, S. J.	Texas A&M University	900
Yepes, P.	Rice University	896
Yershov, A. A.	Moscow State University	852
Yoder N. R.	Indiana University	900
Yokkaichi, S.	University of Kyoto	813
Yokosawa, A.	Argonne National Laboratory	925, 880
Yokoya, K.	KEK	880
Youn, M.	University of Houston	929
Yoshi, M.	KEK, National Laboratory for High Energy Physics	932
Yoshimura, Y.	KEK, National Laboratory for High Energy Physics	787
Yosoi, M.	Kyoto University	906, 885
Youn, M.	University of Houston	940

---

**Z**

---

Zajc, W. A.	Columbia University	910, 866
Zeller, M.	Yale University	926, 865
Zeps, V.	University of Kentucky	931, 907, 885
Zeps, V.	Carnegie-Mellon University	813
Zhang, W. N.	Harbin University	895
Zhang, Y.	SUNY at Stony Brook	877
Zhang, Y.	Columbia University	910, 877
Zhao, D.	Northwestern University	852
Zhao, K.	City College of New York	891
Zhu, F.	Brookhaven National Laboratory	866
Zhu, Q.	University of California-Riverside	866



Zhu, Y.	City College of New York	891
Zieminska, D.	Indiana University	852
Ziliak, Z.	Indiana University	852
Zimmerman, D.	University of Minnesota	821
Ziock, H.	Los Alamos National Laboratory	933, 920
Zou, C.	SUNY at Stony Brook	877
Zou, C.	University of California-Riverside	917
Zumbro, J.	Los Alamos National Laboratory	933, 920
zu Putlitz, G.	University of Heidelberg	821
Zybert, R.	University of Birmingham	813