

Radio Frequency Performance of DSS 14 64-m Antenna at X-Band Using a Dual Hybrid Mode Feed

A. J. Freiley

Radio Frequency and Microwave Subsystems Section

The 64-meter antenna X-band system at DSS 14 was evaluated to determine the performance with the new dual hybrid mode feed. The peak system efficiency increased from 42.0 to 45.6 percent resulting in a 0.36 dB increase in antenna gain. The new measured gain is 71.6 dB. Antenna pointing, beamwidth, optimum subreflector focusing, and operating system temperature were unchanged from the previous feed. Some evidence of antenna aging is apparent (from the 1973 measurements reported earlier) both in peak gain and in the pointing angle at which the peak occurs.

I. Introduction

The X-band radio frequency performance of the 64-meter antenna at DSS 14 was measured at 8420 MHz (3.56-cm wavelength) to evaluate the improved antenna gain expected from a dual hybrid mode feed, part of an overall Voyager enhancement program within the DSN. The total Voyager enhancement task is to realize a 2 dB improvement in signal-to-noise ratio (SNR), to improve the imaging science return from the Voyager mission at Saturn and beyond. To achieve this goal the task was separated into three areas: (1) 1.1 dB SNR improvement by real-time arraying with an X-band 34-m collocated aperture; (2) 0.6 dB increase in SNR by reduced noise temperature of the X-band traveling wave maser (TWM); and (3) 0.3 dB increase in 64-m antenna gain through the use of a dual hybrid mode feedhorn to achieve improved aperture illumination.

It is the intent of this article to examine the change in antenna performance due to the installation of the new feed. The remaining aspects of the Voyager enhancement task will be reported elsewhere. Additionally, DSS 14 will have a complete resetting of all main reflector panels as well as a new

improved subreflector. The final DSS 14 antenna gain should therefore be 0.5 dB above the already improved levels discussed herein.

To evaluate the antenna gain performance, radio metric measurements of selected radio sources were undertaken at X-band prior to, and just after, the installation of the new feed. The radio sources were selected to maintain consistency with previous measurements. While absolute accuracies are always problematical in this work (inaccuracies on an absolute scale are most likely larger than ± 0.3 dB), the gain *differences* reported here are considered highly accurate as well as having high resolution (hundredths of a dB).

II. Antenna Modification

The X-band Receive Only (XRO) feedcone has been reconfigured to provide improved performance and capabilities in support of the Voyager mission (see Ref. 1 and 2). The functional block diagrams of the previous XRO system configuration and the new dual hybrid mode system configuration are presented in Fig. 1. Figure 1(a) shows the major functioning

components of the previous XRO system in use prior to October 1978. The dominant features of this configuration were a 22 dB corrugated conical feed horn, selectable polarization and a single low-noise, traveling wave maser (TWM) at 8 K. Figure 1(b) shows the major functional components for the new dual hybrid mode feed. The modification consisted of a new feed assembly with a dual hybrid mode horn, quarter-wave polarizer, orthogonal mode transducer and dual traveling wave masers. The dual hybrid-mode feed horn (Ref. 3) improved the aperture illumination which was expected to increase the antenna system efficiency or gain. The quarter-wave polarizer, orthogonal mode junction, and the dual TWM's provide the capability to route right or left hand circular polarization (RCP or LCP) to either of the TWMs and also provide the simultaneous reception of R and LCP signals to fulfill a radio science polarization requirement. This combination also allows redundancy to receive signals of one polarization if spacecraft system problems arise.¹ The tests reported herein are using the original (8 K) maser. Later installation of the improved (3.5 K expected) machines is yet to be achieved.

III. Technique

The radio metric technique used to evaluate the new system consisted of four parts. The first is the boresighting of the antenna to ensure the RF beam peak of the antenna is coincident with the radio source. The Antenna Pointing System (APS) utilizes the conical scan technique with a total power radiometer to automatically determine the boresight changes and update the pointing commands to maintain optimum pointing (Ref. 4). Conical scan period, radius, gain, and bandwidth are critical parameters that must be set to ensure adequate pointing of the antenna. To minimize tracking errors for radio source observations the scan radius should be near the half power points of the main beam for maximum sensitivity to pointing errors. Limitations on the scan radius and scan period are imposed by encoder errors and RF/IF system gain fluctuations which effect tracking accuracy. The conical scan gain constant varies inversely with the strength of the radio source observed, so caution should be employed when observing more than one source in rapid succession. Selecting the optimum set of conical scan parameters for each source is an iterative process within certain limits until adequate pointing is achieved.

¹The Voyager spacecraft is unique in that, for efficiency reasons, redundant final amplifiers at X-band are "hardwired" to RCP and LCP flight orthomode ports. Thus, an amplifier failure on the spacecraft results in a switchover which includes a polarization change as well as the amplifier change *per se*.

At X-band the focal length change of the 64-m antenna due to large-scale structural deviations induced by gravity are a critical parameter to be monitored during precision gain measurements. Gain errors of 0.5 to 1 dB are likely if attention is not given to focusing. Therefore, while tracking a radio source, the optimum focus setting was determined by stepping the subreflector through 1 to 2 inches of travel near the optimum position. The focus is then updated to this new position prior to taking noise temperature measurements.

The third part of the radio metric technique is the actual antenna gain or efficiency measurement. The radio metric technique consists of the on-off source operating system temperature measurements (T_{op}) using the noise-adding radiometer (NAR) (Ref. 5). From two off-source and one on-source measurement, the increase in system temperature due to the radio source, ΔT_a (antenna temperature) can be determined for a particular elevation angle. The antenna efficiency at that elevation angle is the ratio of antenna temperature, ΔT_a , to the source temperature, T_s (the temperature observed by a 100 percent efficient antenna). By observing sources at various elevation angles the antenna efficiency with elevation can be characterized. A more detailed description of the on-off measurements and the calculation to obtain antenna efficiency is given in Ref. 6.

The calibration of the NAR is an important part of the measurement scheme. The ambient load is the well-calibrated physical temperature standard used to calibrate the NAR noise diode. NAR calibration is achieved when the NAR measurement of the system temperature on the ambient load equals the physical temperature of the load plus the maser and receiver follow-on temperature.

IV. Radio Source Calibrators

The standard radio source calibrators – 3C48, 3C123, 3C274 (Virgo A), 3C295, 3C380 and DR21 – were selected to maintain consistent calibrations both before and after the feed replacement. The assumed flux density and other related source parameters are given in Table 1. The assumed flux densities, S , are the result of a series of radio source ratio measurements, reported in Ref. 7. The source temperature, T_s , is the standard value on which the system efficiency is based and is determined from the flux density at the frequency of interest for a 100 percent efficient antenna by the equation

$$T_s = \frac{S A_p}{2k}$$

where A_p is the physical area of the antenna and k is Boltzmann's constant (1.380622×10^{-23} W/Hz K). The typical corrected peak antenna temperatures are also listed for reference in any future work. The source resolution correction, C_r , was applied to the measured antenna temperature to correct for the systematic error resulting from partial resolution of the radio source. The relatively strong sources, 3C274 and DR21, were the standard sources predominantly used to determine the optimum focus settings for this series of antenna measurements. All of the listed sources are considered to exhibit stable flux levels with time and were used to determine the gain and efficiency of the antenna system.

V. Radio Metric Data

The radio metric measurements at DSS 14 were taken to determine the increase in antenna gain and other parameters due to the installation of the modified XRO feed system. Between July and October 1978, baseline performance of the antenna system was defined (with difficulty) and during November and December 1978, the improved performance was determined.

The antenna pointing system generally performed well during the observations. A comparison of pointing offsets prior to and following the feed modification indicated no notable change as determined by the conical scan technique. The beamwidth of the antenna at X-band (8420 MHz) was 0.038 degrees (137 arc sec) and remained constant before and after the feed replacement. The scan radius used to boresight the antenna ranged from 0.015 to 0.020 degrees and the scan period was about 60 seconds. At one point during the baseline performance observations, the master equatorials I and II were not in operation, causing unacceptable pointing variations. The observations during this session exhibited large fluctuations resulting in the cancellation of the remaining portion of that observing session. Data gathered at this time was not included in the baseline performance. Without the master equatorial, the antenna pointing system is *not capable* of maintaining pointing accuracies necessary for high quality X-band antenna use.

The subreflector axial focus of the antenna as a function of elevation angle was measured using the NAR. While tracking on a radio source the subreflector was positioned in steps of 0.1 inches through a 1- or 2-inch range about the optimum position. At each step the NAR would sample the operating system temperature and by inspection the operator could determine the optimum focus setting at that elevation. Each focus measurement characterized the gain loss due to defocusing of the antenna, the peak of which is the point of optimum focus. As part of the normal data reduction, the system temperature data was curve fitted and normalized to the peak

allowing interpolation between the steps to determine the exact setting; corrections for the systematic errors were also applied to the measurements of system efficiency. Typical corrections for improper focus ranged about 1 to 2 percent. Figure 2 shows the typical normalized gain loss data. The defocusing gain loss is -3 dB when the subreflector offset from the optimum is about one wavelength (1.2 to 1.4 inches). This elaborate measurement was one of a few which characterized the defocusing gain loss. Normally 5 to 7 steps are sufficient to determine the optimum axial focus setting. The defocus gain loss measurements were conducted at various elevations and were found to have no significant elevation-dependent variations, nor was there any change or variation due to the installation of the new feed. No noticeable change in the shape of the defocus gain loss curve was expected and none was observed. The optimum axial focus position for DSS 14 as a function of elevation angle is given in Fig. 3. No bias change in the optimum focus was detected due to the feed change. Winds beyond about 15 miles per hour (24 kilometers per hour) have been noted as affecting the axial focus at X-band. Winds blowing into the aperture (low-elevation angle case) cause the optimum focus to move in the outward direction, which is consistent with a more shallow reflector. Automatic axial focusing of the 64-m antenna subreflector (as a function of elevation angle) is being implemented as part of the substantial overall upgrade of the 64-m network in readiness for the Voyager Saturn encounter. These measurements should be used as design data describing the optimum focusing function of the DSS 14 subreflector. Comparable measurements from the other 64-m antennas are needed since the optimum axial focus function will be unique to each antenna.

At the core of the measurement of antenna parameters is the determination of the operating system temperature. During the course of these tests the operating system temperature was measured using the normal DSN Y -factor instrumentation and the NAR. Initially the measurements of operating system temperature varied from session to session and agreement between the Y -factor and NAR measurements was poor during a given session. When the system is operating normally and correctly the results of each T_{op} measurement system (Y -factor and NAR) should agree to within the accuracies of the measurements. The Y -factor instrumentation T_{op} measurement varied from 28 to 34 K while the NAR T_{op} measurements ranged from 24 to 28 K. Maser tuning and receiver linearity were found to be the two major causes of the disagreement. Once the problems were understood the T_{op} measurements were stabilized by setting maser tuning parameters (gain and bandwidth) more precisely and reducing the maser gain to improve receiver linearity over the operating range (from ambient load $T_{op} \approx 300$ K to operating system $T_{op} \approx 25$ K). Maser gain was nominally maintained at 42 dB. The operating system temperature at 8420 MHz prior to the

feed modification was about 29 K at zenith; following the implementation of the new feed T_{op} at the same frequency also was about 29 K (Y factor measurements). An early XRO feed (1973) with the dichroic plate system operating with a 23 K operating system temperature (Ref. 8). No assured explanation is available for the higher system temperature indicated during the past year at DSS 14; however the Y factor noise instrumentation is suspect and may require work.

The intent of the feedhorn changes was to improve the antenna gain or efficiency of the 64-m antenna. Figure 4 shows the measured increase in overall antenna system efficiency. The system efficiencies in this figure are as would be observed in spacecraft and radio science missions; the measurements have not been corrected for atmospheric loss effects nor the waveguide loss effects, but have been corrected for effects of source size (C_p in Table 1). Therefore, Fig. 4 includes the normal atmospheric extinction. The original feed performance peaked at 52 degrees elevation with a measured system efficiency equaling 42.0 percent (July 1978). The measurement scatter of this data set was attributed to the T_{op} measurement difficulties previously mentioned. The curve fit is biased to best describe the base performance in spite of the measurement difficulties encountered during that period. The dual hybrid feed performance also peaked at about 52 degrees elevation with a system efficiency of 45.6 percent (November, 1978). The lower measurement scatter is due to the well-controlled linearity and maser tuning and is more typical of this class of measurements. With the installation of the dual hybrid-mode feed, the antenna system efficiency increased by 3.6 percent, which will increase peak antenna gain by 0.36 dB. The antenna gain of DSS 14 at 8420 MHz has increased from 71.27 dB (42.0 percent efficient) to 71.63 dB (45.6 percent efficient) as determined by this series of measurements.

When comparing the July 1978 performance (original feed) with that of 1973 (Ref. 8), the system efficiency with elevation has pronounced differences in shape. The 1973 measurements show a peak near 40 degrees elevation with a system efficiency of 42.6 percent. The July 1978 measurements show a very slight loss in peak efficiency (42.0 percent) but a more important shift in the elevation angle at which the gain peak occurs, as well as reduced gain at low-elevation angles. This is a serious effect (about 0.5 dB gain loss at 20 degrees elevation) compared with the 1973 performance. Presumably, the scheduled resetting of the main reflector panels at DSS 14 will correct the low-elevation angle problem which might be interpreted qualitatively and loosely as "aging." Nevertheless, the dual hybrid mode feed performance definition is totally based on 1978 measurements, and the new feed yields the anticipated improvement (Ref. 3).

VI. Conclusions

The performance of the new dual hybrid mode feed installed on the 64-m antenna at DSS 14 has been evaluated at X-band (8420 MHz) using radio metric techniques. The peak system efficiency at 52 degrees elevation increased, as expected, from 42.0 to 45.6 percent resulting in a 0.36 percent increase in antenna gain over that measured with the original feed. The shape of the efficiency curve with elevation angle is noticeably different from 1973 measurements. The antenna pointing was examined and no significant shifts were detected. The operating system temperature was not affected by the feed change remaining at about 29 K (Y -factor measurements) at zenith; it remains higher than expected but relatively stable during later phases of the measurements reported here. Additional work on the noise instrumentation is required; the Y -factor instrumentation is prone to system linearity difficulties.

References

1. Hartop, R. "New X-Band Microwave Equipment at the DSN 64-meter Stations," in *The Deep Space Network Progress Report 42-48*, pp 126-128, Jet Propulsion Laboratory, Pasadena, California.
2. Hartop, R. W., "New X-Band Antenna Feed for DSN 64-meter stations," in *The Deep Space Network Progress Report 42-52*, pp. 71-74 Jet Propulsion Laboratory, Pasadena, California.
3. Thomas, R. F., Bathker, D. A., "A Dual Hybrid Mode Feedhorn for DSN Antenna Performance Enhancement," in *The Deep Space Network Progress Report 42-22*, pp. 101-108, Jet Propulsion Laboratory, Pasadena, California.
4. Ohlsen, J. E., Reid, M. S., "Conical-Scan Tracking with the 64-m-Diameter Antenna at Goldstone," JPL Technical Report, pp. 32-1605, Pasadena, California, October 1, 1976.
5. Batelaan, P. D., Goldstein, R. M., Stelzried, C. J., "A Noise-Adding Radiometer for Use in the DSN," *JPL Space Program Summary*, Vol. II, pp. 37-65, Jet Propulsion Laboratory, Pasadena, California.
6. Freiley, A. J., Batelaan, P. D., Bathker, D. A., "Absolute Flux Density Calibrations of Radio Sources: 2.3 GHz," JPL Technical Memorandum 33-806, Jet Propulsion Laboratory, Pasadena, California, December 1, 1977.
7. Turegano, J. A., Klein, M. J. "Calibration Radio Sources for Radio Astronomy: Precision Flux Density Measurements at 8420 MHz," (to be published).
8. Freiley, A. J., "Radio Frequency Performance of DSS 14 64-m-Antenna at 3.56 and 1.96 cm Wavelengths," JPL Technical Report 32-1526 Vol. XIX pp. 110-115, Jet Propulsion Laboratory, Pasadena, California.

Table 1. Radio source calibrations

Source	Flux density 8420 MHz $S^{(a)}$ (Jansky)	Source temperature (100% efficient antenna) T_s (Kelvin)	Typical antenna temperature T_a (Kelvin)	Source resolution correction C_r	Source position (1950.0)	
					Right ascension (hr-min-sec)	Declination (deg-min-sec)
3C48	3.33	3.88	1.77	1.000	01 34 49.8	32 54 20
3C123	10.05	11.7	5.34	1.007	04 33 55.2	29 34 14
3C274	46.0	53.6	24.5	1.085	12 28 17.3	12 39 48
3C295	3.69	4.30	1.96	1.000	14 09 33.5	52 26 13
3C380	4.87	5.68	2.59	1.000	18 28 13.5	48 42 41
DR21	21.4	25.0	11.4	1.030	20 37 14.2	42 09 07

^aFlux density values from Ref. 7.

(a)

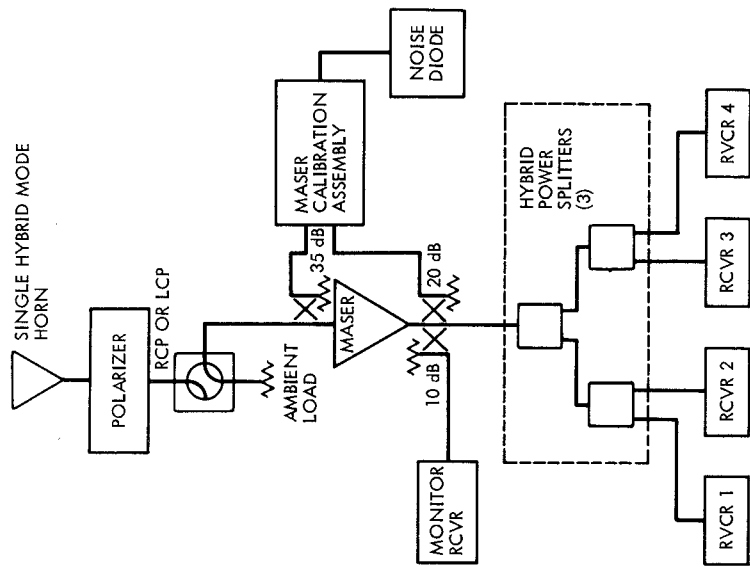

(b)

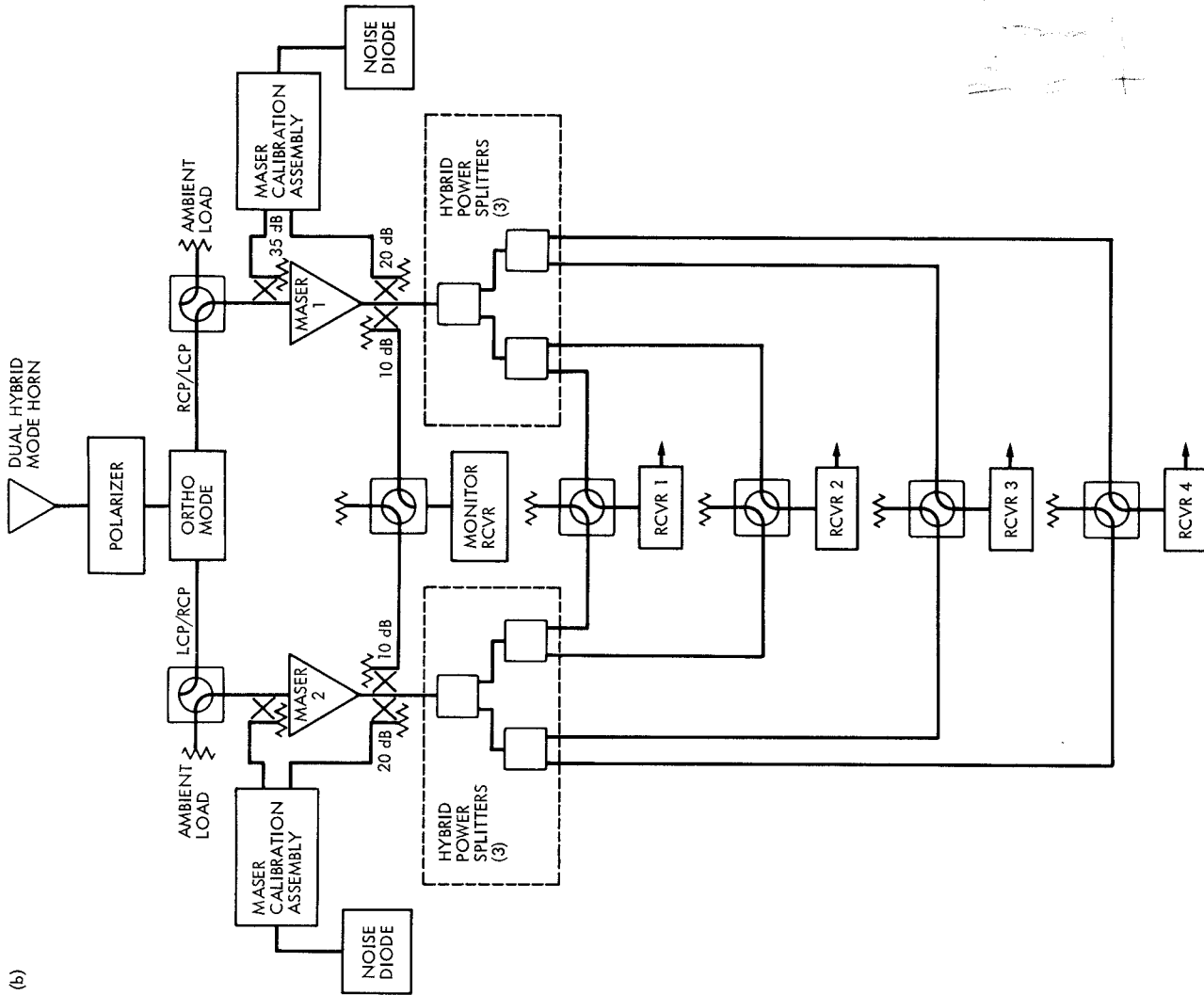

Fig. 1. Functional block diagram of (a) original XRO feed system (prior to October 1978), and (b) modified XRO feed system (after October 1978)

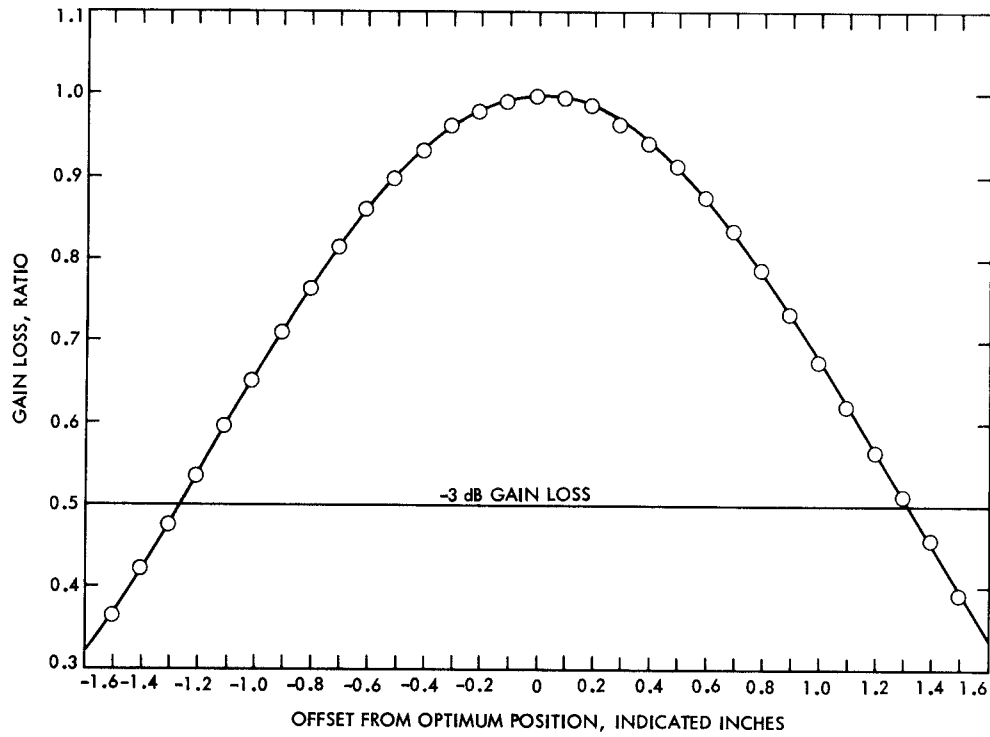

Fig. 2. X-band normalized defocused gain loss as a function of offset from optimum position

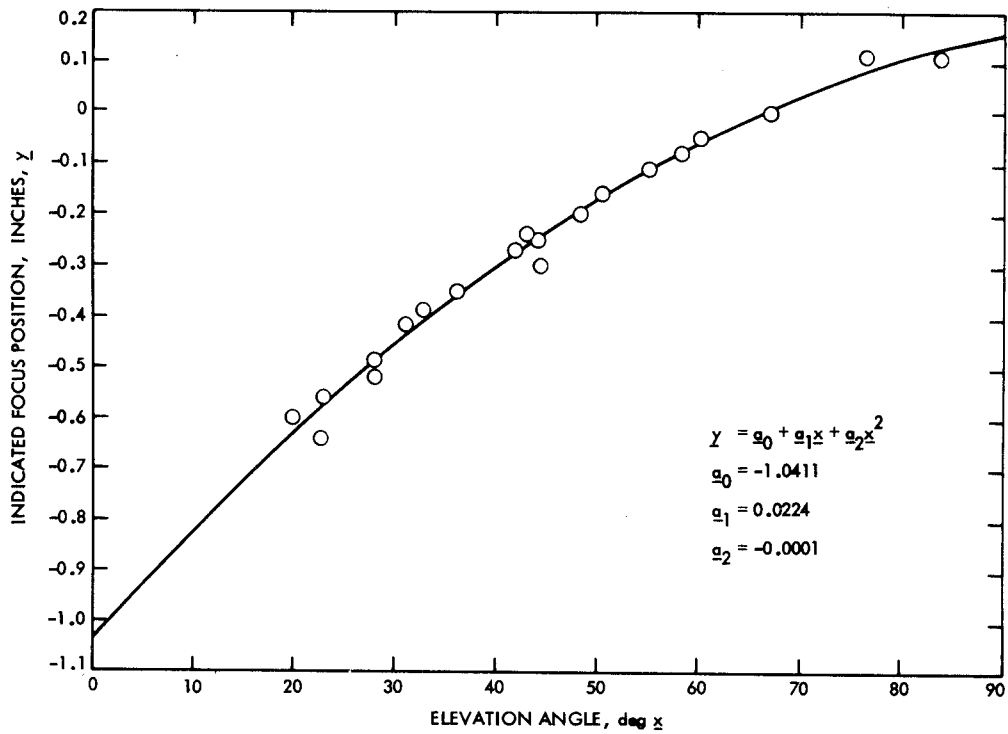

Fig. 3. X-band optimum axial focus position as a function of elevation angle

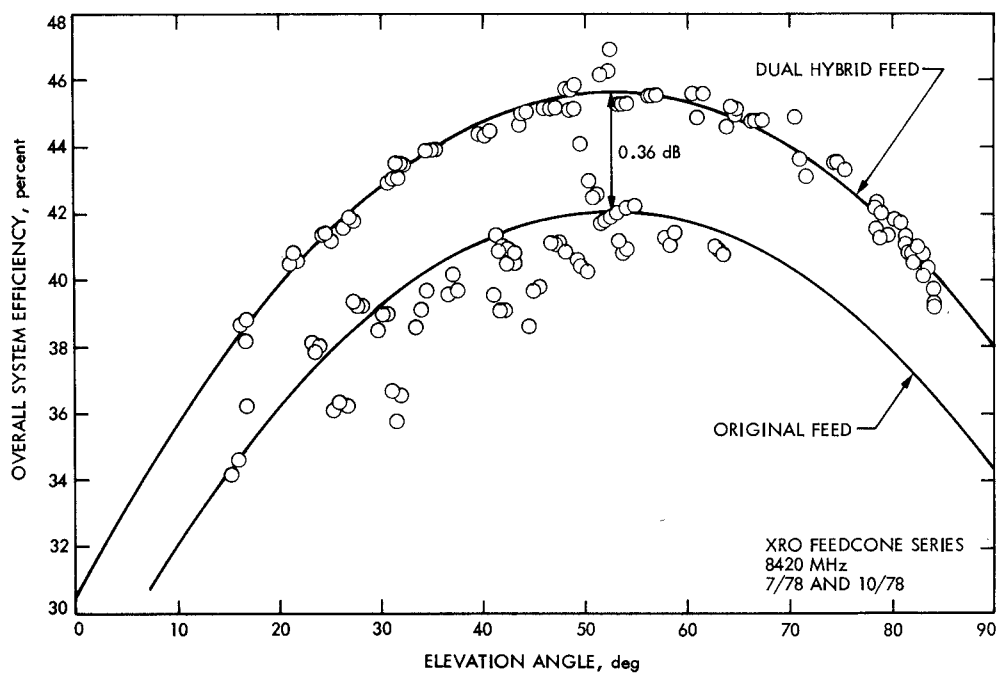

Fig. 4. DSS 14 overall antenna system efficiency at X-band