

PLC INTERFACE TO NSLS FRONT-END SYSTEMS*

S. Ramamoorthy, S. Buda, J. Oliva, G. Ramirez, BNL, N.Y., USA

Abstract

The front-end systems at the National Synchrotron Light Source (NSLS) facility are VME-based computers and most of them use VME I/O peripheral boards for hardware control and data acquisition. With the decision of the NSLS hardware engineers to use programmable logic controllers (PLCs) for the beam line status, RF and power supply systems, the front-end systems are being upgraded to interface with PLCs. This paper describes the PLC hardware used and the software interface to the control system.

1 INTRODUCTION

The NSLS facility at the Brookhaven National Laboratory, USA has two storage rings, one for VUV at 800 Mev and the other for X-ray at 2.8 Gev and a shared injection system (a Linac and a Booster ring). The control system at NSLS has a two-level architecture consisting of HP workstations for the higher, or operator, level and real-time front-end controllers for the lower, or equipment level. The communication link between the two levels is high-speed Ethernet. Except for a couple of systems that use PC-based computers, all the front-end systems are VME-based computers running real-time software known as the NSLS Control Monitor [1], which is built around the real-time VxWorks operating system. The front-end computers are referred to as **Micros** at NSLS.

A basic micro consists of a VME-based single board computer with Ethernet Controller, a general purpose light source board (GPLS), and a battery-backed up memory board. The GPLS provides timers, serial ports, an interrupter module and an ASCII video display generator. Depending on the equipment to be controlled and monitored, various types of VME I/O peripherals are used. Instruments with GPIB and RS232 interfaces and Camac controllers are also supported.

Some systems have more than 1000 analog signals. When all the boards cannot be housed in a single VME crate or when hardware units controlled by the same micro are distributed in/around the ring, multiple crates with bus extenders have been used. Due to the high cost of the VME products some of the micros provided only the controls and data acquisition essential for the ring operations. Lack of diagnostic information from the micros motivated the hardware engineers to use PLCs to build their own controls and diagnostics. They also preferred to replace the traditional digital circuits with PLC logic. With the introduction of Ethernet adapters for

the PLCs, the control system can easily exchange information with the systems controlled by PLCs.

2 PLC CONTROLLERS USED AT NSLS

Modicon PLCs from Schneider Automation Inc. have been selected by the hardware engineers. The decision was based on the cost, technical support, different networking options, availability of a wide range of inexpensive I/O modules and the software tools available for the development of PLC logic. The initial project on the power supply controls used TSX Quantum Controllers. The logic is stored and run in the Quantum processor. An Ethernet module connected to the processor via quantum-back-plane provides the link to the control system. Recent projects use the processors from the TSX Momentum family, which includes processor adapters, communication adapters and option adapters (to provide the processor with additional networking capabilities). A variety of I/O modules (ADCs and Bit I/Os) are used. The PLC-CPU communicates with the I/O modules through the IO-bus or Modbus Plus network. The Concept Software which complies with the Microsoft windows GUI interface and the IEC 1131-3 standards, and which has a Web interface provides a great development and debugging environment for the PLC program developers.

3 SOFTWARE DRIVER FOR PLC

The complexity and diversity of various hardware units make each micro unique but the real-time software in the micro presents a standard interface to the high-level programs. The high-level programs access the hardware signals by identifiable names. A set of READ commands is used to acquire data from the hardware. A set of WRITE commands controls the hardware. The micro treats the PLC as an intelligent slave unit with Ethernet as the communication link. The communication protocol used over the Ethernet is called Modbus-TCP/IP, which basically embeds a MODBUS frame into a standard TCP/IP frame. The information for packaging messages is available in the MODBUS/TCP specification manual [2].

A software driver has been developed to interface PLCs with a micro [3]. The driver invokes a client task, which opens a TCP connection to the specified PLC server and sends Read Multiple Registers requests periodically to get data from the PLC. The driver supports multiple clients. The number of clients has been arbitrarily chosen as 5 but it can be extended if necessary.

If the PLC goes off-line or if the physical link is lost, the software reports the error to the Control Room, closes

*Work performed under the U.S. D.O.E. Contract NO:
DE-AC02-98CH10886

the current connection and retries. The application modules in the micro communicate with the client tasks using the utility functions (Initialization, Read and Set) built in the driver [3].

4 MICROS WITH PLCs

The following section describes the three systems that have been upgraded or are being upgraded.

4.1 Power Supply Systems

Different types of power supplies are in use in various parts of the injection system and storage rings. The Booster-UV transport micro controls the power supplies for the booster to UV transfer line. The supplies for the corrector magnets are controlled by the uvtrim micro. The main magnet micro controls the supplies for the UV dipole, quadrupole and sextupole magnets. Due to the cost of the VME I/O peripherals as well as lack of slots in the VME crates, the micros basically control the settings of the power supplies. The real read-backs from the system are checked against tolerance limits. The on/off control, status check and test for fault conditions have not been implemented in the micros. Manual on/off controls were used. Even though many power supplies are equipped with fault indicators (digital signals) for temperature, water, security, etc. the information was not passed to the control system. Diagnosing the problems related to power supplies was not an easy task. The power supply systems were upgraded using PLCs. The logic is run in the CPU in a TSX quantum controller, which is coupled to an Ethernet adapter. Sixteen non-intelligent I/O modules (twelve 16-Input and Output TIO-170ADM350I10 modules and four 16-input TIO-170BDI-34200 modules) have been used for on/off control, monitoring on/off status and for reading the fault signals. The status and fault signals are also sent to local display panels. The Quantum controller and the TIO modules are connected by Modbus Plus network. The micros that are controlling the power supplies send control commands via Ethernet. The PLC logic decodes the commands and sets the necessary bits in the appropriate TIO output module. The PLC logic periodically reads the TIO input modules and saves the on/off status and fault signals in the PLC memory. The micros responsible for the power supplies can access the data using the READ function provided by the driver.

4.2 X-ray RF1 System

A 52.88MHz RF signal from a frequency synthesizer is fed through an RF processor to an amplifier chain comprised of a 3kw solid-state amplifier and a 125kw high power tetrode amplifier to drive an RF accelerating cavity in the storage ring. The RF processor in conjunction with a servo unit completes a feedback loop for amplitude and phase control. A fraction of the

amplifier output and cavity field is fed back to the RF processor where phase and amplitude detectors produce dc signals that are output to the servo unit. The servo unit compares them with the reference amplitude and phase levels set by the operator and adjusts the level and phase of the RF drive to compensate for changes due to beam loading phase shifts within the amplifier chain and temperature variations (Fig 1).

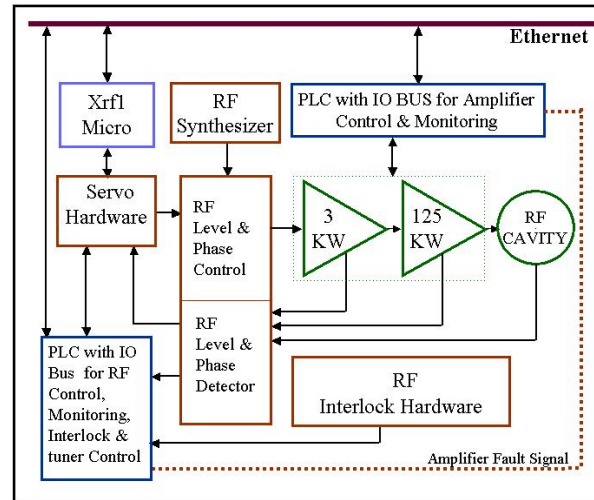

Fig. 1 X-ray RF1 System

Currently, a control chassis built with discrete electronics incorporates the servo unit, amplifier monitors and the interlock system for the RF turn-on, turn-off sequences and emergency shutdown of the RF system.

Various signals from the power supply, amplifiers, cavity and interlock status are monitored by a micro. The original micro uses Acromag ADC cards for measuring the signals at 20 Hz rate. A NSLS DAC board is used to send the operator specified set-points for RF level and phase to the servo unit. When the energy of the beam is ramped, the RF level is also ramped as per the ramp table. Various faults associated with the amplifiers and the RF cavity, are read by the micro using BIT IO VME cards. The micro software includes a redundant interlock logic (back-up in case of hardware failure in the control chassis) for turning on and off the amplifiers, and for emergency shutdown. The micro displays the data on a local CATV channel. Alarm conditions are highlighted on the display and are sent to the alarm handler.

The control chassis is 20 years old and the components used for the discrete circuits have become obsolete. It cannot be easily expanded to meet the new system requirements. Reliability and troubleshooting have become major issues. Hence the RF system is being upgraded using programmable logic controllers. A modular design is used which will allow future expansion, better diagnostics and flexibility for later modifications.

The major functions of the control chassis that provide the on/off control, data acquisition and interlocks are being replaced by PLC logic. Two PLCs are used. One controls and monitors the amplifiers. The other PLC

controls RF turn-on/off sequence and monitors the cavity interlocks and cavity signals. Both PLC systems use TSX Momentum processors, which are equipped with Ethernet for communication with the control system. The PLC system for the amplifier controls uses two analog units each consisting of 8 differential inputs for reading the amplifier signals. For digital faults and for amplifier on/off controls, one Bit I/O module is used. The PLC system controlling the RF section uses two analog input units for cavity signals and two Bit I/O modules for controlling the RF and for monitoring the cavity faults. The PLCs communicate with the I/O modules via IO bus. An amplifier fault signal is hard-wired to one of the Input module bits of the RF PLC unit. This will trip the RF if the amplifiers fail.

The micro will send the operator commands to the two PLCs via Ethernet. It will read all the analog and digital faults from the PLC memory and generate TV displays as before. DAC controls, which require fast response while ramping, will be implemented in the VME micro software.

4.3 UV Beam Line Status System

The UV ring has 16 beam lines, each having a maximum of 3 branches. Each beam line is equipped with an electro-mechanical assembly consisting of solenoids that energize the safety shutters, photon shutters and mask, fast valve controls and sensors for beam line vacuum, beam-trip etc. Each beam line has a unit for controlling the shutter and vacuum valves and for monitoring their status. Each unit is located close to the respective beam line. Until now, relay logic was used for sequencing the operations and interlocking of the various components. In the earlier design, all the relay logic units were centrally located inside the ring. The number of cables that are run between each beam-line and the relay logic system is 20. The relay logic also supplied status data to the UV beam line micro. This adds two extra cables for each beam line. The micro uses a VME-based BIT I/O card (Micro Dimension 200 board) to read the shutter status, generates a real-time display on a local CATV and reports alarm conditions to the alarm handler. The only information passed on to the control system is the status of the safety shutter and mask. All other faults are not routed to the micro due to excessive cabling. The relay logic being a hardware unit, does not lend itself for easy modifications and upgrade of the interlock system. The interlock system is now being upgraded using PLC controllers. The TSX momentum family products are used for this system. An IO box consisting of PLC-CPU and appropriate IO modules is set up close to the beam lines and all the cables that run between the interlock components and the relay logic unit were re-routed to the PLC IO box (Fig. 2).

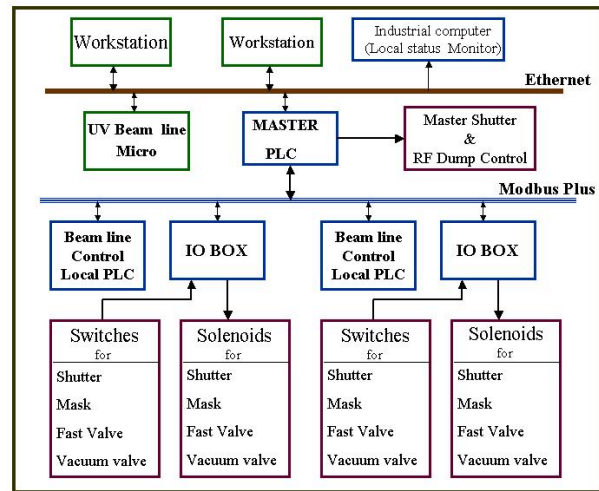

Fig. 2 UV Beam line System

The functions implemented by the relay logic were replaced by the PLC logic executed in the local PLC-CPU. A master PLC with Ethernet adapter has been programmed to control the master shutter and RF permit for the storage ring operation. All the local PLCs and the Master PLC communicate via Modbus Plus network. Information from all local PLCs are passed to the master PLC using peer cop communications. All the information regarding the beam line status is available in the master PLC. The beam line status micro polls the master PLC at 5 Hz rate and gets the data. The upgrade is being done in incremental stages during short maintenance periods. The upgrade requires connecting the local controls to the Modbus Plus bus that is already in place. The VME software is easily modified by replacing the device driver that uses the VME BIT IO by the driver function provided by the MODBUS software library.

5 CONCLUSIONS

The integration of the micros and the PLCs has been simplified with the availability of the Ethernet adapters. The PLC software driver can be easily incorporated into any operational micros.

6 ACKNOWLEDGEMENTS

The authors wish to thank R. Biscardi, R. D'Alsace, M. Fulkerson, K. Pederson, W. Rambo, N.A. Towne, J. Vaughn and E. Zitvogel for discussions and assistance.

7 REFERENCES

- [1] S. Ramamoorthy et al, "NSLS Control Monitor", Proc IEEE, 1849, PAC 1993.
- [2] A. Swales, "Open Modbus/TCP Specification" <http://www.modicon.com/cpenmbus/eio/enetio.html>.
- [3] S. Ramamoorthy et al, "NSLS Control System Interface to Modicon PLC", Proc ICALEPCS 2001, 185.