

Longitudinal Emergency Control System Using Thrust Modulation Demonstration on an MD-11 Airplane

John J. Burken, Trindel A. Maine, Frank W. Burcham, Jr.,
and Jeffery A. Kahler

July 1996

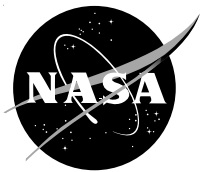

National Aeronautics and
Space Administration

Longitudinal Emergency Control System Using Thrust Modulation Demonstration on an MD-11 Airplane

John J. Burken
Trindel A. Maine
Frank W. Burcham, Jr.
*NASA Dryden Flight Research Center
Edwards, California*

Jeffery A. Kahler
*Honeywell, Inc.
Phoenix, Arizona*

1996

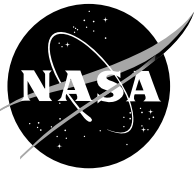

National Aeronautics and
Space Administration

Dryden Flight Research Center
Edwards, California 93523-0273

LONGITUDINAL EMERGENCY CONTROL SYSTEM USING THRUST MODULATION DEMONSTRATED ON AN MD-11 AIRPLANE

John J. Burken,^{*} Trindel A. Maine,^{*} Frank W. Burcham, Jr.[†]
NASA Dryden Flight Research Center
Edwards, California

Jeffery A. Kahler[‡]
Honeywell, Inc.
Phoenix, Arizona

Abstract

This report describes how an MD-11 airplane landed using only thrust modulation, with the control surfaces locked. The propulsion-controlled aircraft system would be used if the aircraft suffered a major primary flight control system failure and lost most or all the hydraulics. The longitudinal and lateral-directional controllers were designed and flight tested, but only the longitudinal control of flightpath angle is addressed in this paper. A flight-test program was conducted to evaluate the aircraft's high-altitude flying characteristics and to demonstrate its capacity to perform safe landings. In addition, over 50 low approaches and three landings without the movement of any aerodynamic control surfaces were performed. The longitudinal control modes include a wing engines only mode for flightpath control and a three-engine operation mode with speed control and dynamic control of the flightpath angle using the tail engine. These modes were flown in either a pilot-commanded mode or an instrument landing system coupled mode. Also included are the results of an analytical study of an autothrottle longitudinal controller designed to improve the phugoid damping. This mode requires the pilot to use differential throttles for lateral control.

Nomenclature

A_{lon} longitudinal state derivative matrix
 B_{lon} control input derivative matrix
c.g. center of gravity

C_{lon} state output matrix
 D_{lon} control input observation matrix
EPR engine pressure ratio (turbine and inlet total pressures)
FADEC full-authority digital engine control computers
FCC flight control computer
FCP flight control panel
 \dot{h} sink rate, ft/sec
ILS instrument landing system
 K_{vc} flightpath error feed-forward gain, deg
 K_{vi} pitch integrator error gain, 1/sec
 K_q pitch rate feedback gain, deg/deg/sec
 K_{secrs} velocity error feedback gain, deg/kn
 K_{thad} pitch angle feedback gain, deg/deg/sec
 K_{vm} center engine washout gain, lb
MCDU multifunction control and display unit
PCA propulsion-controlled aircraft
PIO pilot induced oscillation
 q pitch rate, deg/sec
 t time, sec
 uu x axis velocity perturbation, ft/sec
 Vel velocity or airspeed, kn
 s Laplace transform
 ww z axis velocity perturbation, ft/sec
 x_{lon} longitudinal state vector
 α angle of attack, deg
 γ flightpath angle, deg

^{*} Aerospace Engineer.

[†] Chief, Propulsion Branch. Associate Fellow AIAA.

[‡] Flight Control Engineer.

Copyright © 1996 by the American Institute of Aeronautics and Astronautics, Inc. No copyright is asserted in the United States under Title 17, U.S. Code. The U.S. Government has a royalty-free license to exercise all rights under the copyright claimed herein for Governmental purposes. All other rights are reserved by the copyright owner.

γ_{cmd}	flightpath angle command, deg
γ_{err}	velocity error
θ	pitch attitude, deg
$\dot{\theta}$	pitch attitude rate, deg/sec
ϕ	roll attitude, deg

Introduction

Aircraft flight control systems are designed with extensive redundancy to ensure a low probability of failure. During recent years, however, several aircraft have experienced major flight control system failures, leaving engine thrust as the only control effectors.^{1,2} In some of these emergency situations, the engines were used to maintain control of the airplane flightpath angle, γ . In the majority of the cases surveyed, crashes resulted, and over 1200 people have died.¹

The challenge was to create a sufficient degree of control through thrust modulation to control and safely land an airplane with severely damaged or inoperative flight control surfaces. Meeting this challenge is the objective of the Propulsion-Controlled Aircraft (PCA) Emergency Backup System. The PCA emergency backup flight control system requires that the airplane have at least two engines, preferably two wing engines. In addition, the normal control surfaces can not be locked in a hardover position which could exceed the moments resulting from the thrust of the engines.

The National Aeronautics and Space Administration, Dryden Flight Research Center, Edwards, California, has performed nonlinear and linear analytical studies and conducted several flight-test programs investigating the PCA concept. Results of these programs²⁻⁶ show that gross control can be obtained by manually moving the throttles. However, making a safe runway landing is exceedingly difficult because of low phugoid and dutch roll damping coupled with the high pilot work load near the ground. To improve the performance and reduce the pilot work load, the PCA program was developed. The goal was to make flying an airplane with the PCA system a viable task with minimal or no previous pilot training with this system.

This report describes the longitudinal PCA control systems and flight test results of four modes:

- Mode A—using the wing engines only for control of flightpath angle, γ .
- Mode B—using the tail engine for speed control in conjunction with mode A.

- Mode C—using all the wing and tail engines for dynamic control of γ and speed control.
- Mode D—using an existing autothrottle system for γ control. The autothrottle system was developed to provide a simpler implementation that did not require changes to the engine controllers. This system was not flight tested, but simulation results are presented.[§]

Within control modes A, B, and C, the pilot has the option of selecting the instrument landing system (ILS)-coupled with PCA for approach and landing. This option virtually eliminates the pilot work load. Two ILS landings using the wing engines (mode A) were performed, and one is presented in this report. The lateral-directional controller is described in reference 7.

Test Vehicle Description

The MD-11 airplane is a large, long-range, three-engine, wide-body transport. This airplane is 202 ft long, has a wing span of 170 ft, and a maximum takeoff gross weight of 618,000 lb (fig. 1).

Flight Control Systems

The MD-11 airplane has a mechanical flight control system with irreversible hydraulically powered actuators. The hydraulic power provided by three independent systems is intended for fail-safe capability. Essential control functions may be maintained by any one of these three systems. Pitch control is provided by dual elevators on each horizontal stabilizer, and pitch trim is provided by a moveable horizontal stabilizer. Inboard and outboard ailerons supplemented by wing spoilers provide roll control. A dual rudder mounted on a single vertical stabilizer provides yaw control.

The lateral dynamics is controlled by the yaw damper. The longitudinal stability augmentation system controls the pitch dynamics. The aerodynamic surfaces are controlled by hydraulic actuators. The flight control computers (FCC) were built by Honeywell, Phoenix, Arizona, and operate at 20 samples/sec.

The MD-11 airplane is equipped with a flight management system which integrates autopilot, navigation, and autoland functions. The automatic pilot control includes a thumbwheel for commanding flightpath angle, γ_{cmd} .

[§]NASA has a patent pending for mode d.

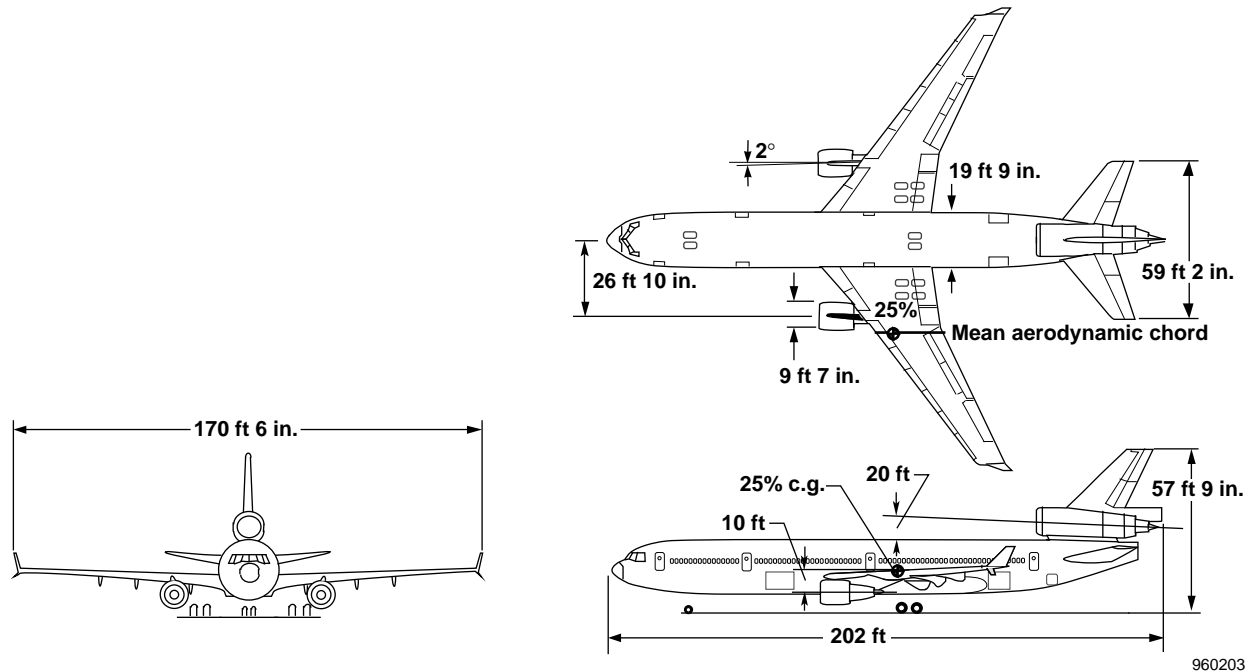

960203

Figure 1. The MD-11 airplane.

Engines

Three Pratt & Whitney (Palm Beach, Florida), (PW4460) high-bypass ratio turbofan engines in the 60,000-lb thrust class power the MD-11 airplane. Two engines are mounted in underwing pods, and the third engine is located at the base of the vertical stabilizer. Each engine has a full-authority digital engine control (FADEC) system in which the software was modified for the PCA program. The modification allowed the FCC to command full-range (0.9 to 1.5) changes in engine pressure ratio (EPR). These commands are normally limited to 5-percent increments. The wing engines are 121 in. below the nominal vertical center of gravity (c.g.), and the tail engine is 240 in. above the vertical c.g. with its thrust axis inclined 2.5° (nozzle pointing down). The crew normally controls the engines with electronic throttles which command a power setting based on EPR.

As is typical for high-bypass turbofans, thrust response is initially very slow. Once thrust levels are above 20 percent, the engine response improves dramatically. An “approach idle” setting when the flaps are extended beyond 27° maintains the idle revolutions per minute (RPM) at a sufficiently high level, so the 8-sec from idle to full-power requirement can be met. A “cruise idle” or “min idle” setting can require as much as 12 sec to go from idle to full power.² If PCA were

engaged with min idle, a pilot-induced oscillation (PIO) could occur because of the large time lags. For this reason, another modification to the FADEC system set the engines to approach idle when PCA was engaged.

Pitch effects occur because of a thrust change with the engine located below the c.g. and slightly tilted up. This situation is typical of the majority of wing engine aircraft. Assuming that the airplane was initially trimmed in level flight, a change in thrust will result in a change in flightpath angle caused by the vertical component of thrust, a moment resulting from the horizontal thrust component because of c.g. offset, and a trim speed stability change. If an engine is mounted above the c.g., as is the case with the MD-11 tail engine, an increase in thrust causes a pitch down moment until the trim speed overcomes the nosedown dynamics. Other effects, such as ram drag and engine inlet location, are also important to consider in the dynamics.⁴⁻⁶

PCA Control System Design

Large civil transports have at least two engines; therefore, the design philosophy was to make the MD-11 PCA program more generally applicable and work primarily with the two engines. If, however, the aircraft has more engines, the control designer should take advantage of this feature. If all the aircraft engines

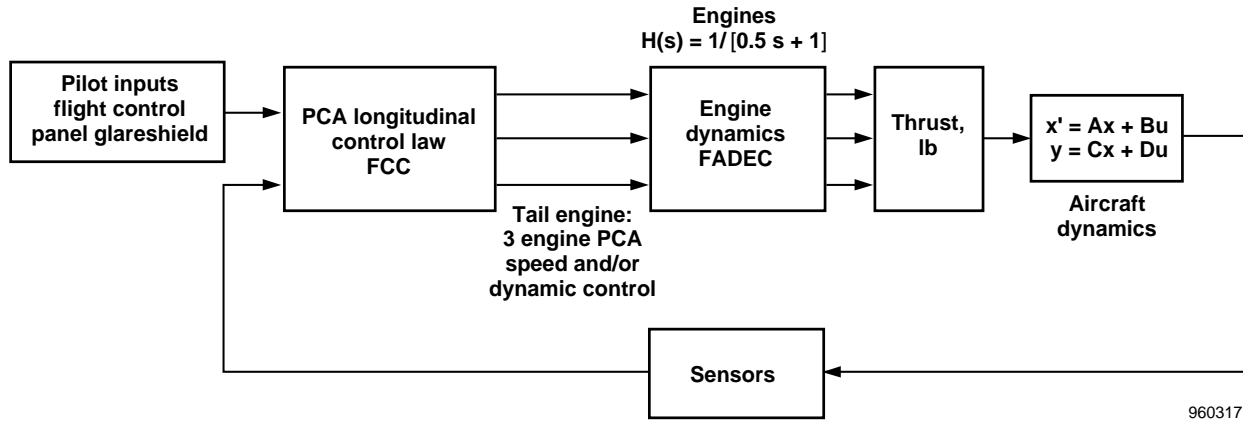

Figure 2. The MD-11 PCA longitudinal functional block diagram for two- and three-engine operation.

do not lay on the same horizontal plane, pitching moment and velocity, Vel , changes can be made independently. The MD-11 airplane falls into this category with the center (tail) engine that can be used directly for trim speed and dynamic control of flightpath angle.

The control laws were developed assuming that the normal control surfaces were not functioning and were not in a hardover position. The PCA uses engine thrust modulation driven by a closed-loop controller to increase bare airframe phugoid damping and allow the pilot to land safely by controlling flightpath angle.

Symmetric or collective throttle inputs are used for longitudinal control. Symmetrical thrust changes cause an initial change in speed and pitch rate, depending on the relative location of the thrust line and c.g.

Classical methods were initially used to design the longitudinal controllers with reasonable first cut results. Later in the flight-test phase, nonlinear time domain methods were employed for rapid control gain adjustments.[¶] The nonlinear simulators were also used to adjust the initial gains determined from linear design. The PCA system was designed with the flexibility to change the control gains in flight by using the multifunction control and display unit (MCDU), which can be used for “dial-a-gain” options.

[¶]Potvin F. Andrew, “Nonlinear Control Design ToolBox,” The MathWorks, Inc., Sept. 1993.

Pilot Vehicle Interface

The flight control panel (FCP) on the glare shield was used for the piloted input paths. The flightpath angle thumbwheel was used for flightpath angle command. When speed control was implemented, the pilot set the commanded velocity with the FCP speed knob (in knots) which produces a velocity error signal after subtracting the current airplane speed. The pilot could also engage the ILS- and PCA-coupled mode by pushing the approach/land button on the glare shield. When PCA was engaged, the approach idle engine settings were used to get faster engine response and avoid a possible PIO. Figure 2 shows a pitch control system. When the PCA system was engaged, the default mode was the wing-engines-only controller (mode A), but the other modes could be selected by entering commands on the MCDU.

Wing-Engines-Only Controller: PCA Mode A

The PCA mode A uses collective thrust commands to the wing engines to control the flightpath angle. The control law uses flightpath angle command to control the glideslope for up-and-away and for approach and landing (fig. 3). The feedback signals selected were pitch attitude, θ ; pitch attitude rate, $\dot{\theta}$; velocity error, Vel_{err} ; and flightpath angle to augment the phugoid damping. Flightpath angle error, γ_{err} , is passed through a proportional plus a limited integral compensator to provide tracking. Pitch attitude, attitude rate, and velocity error are proportionally summed for improved phugoid damping. The gains associated with figure 3 are presented in table 1.

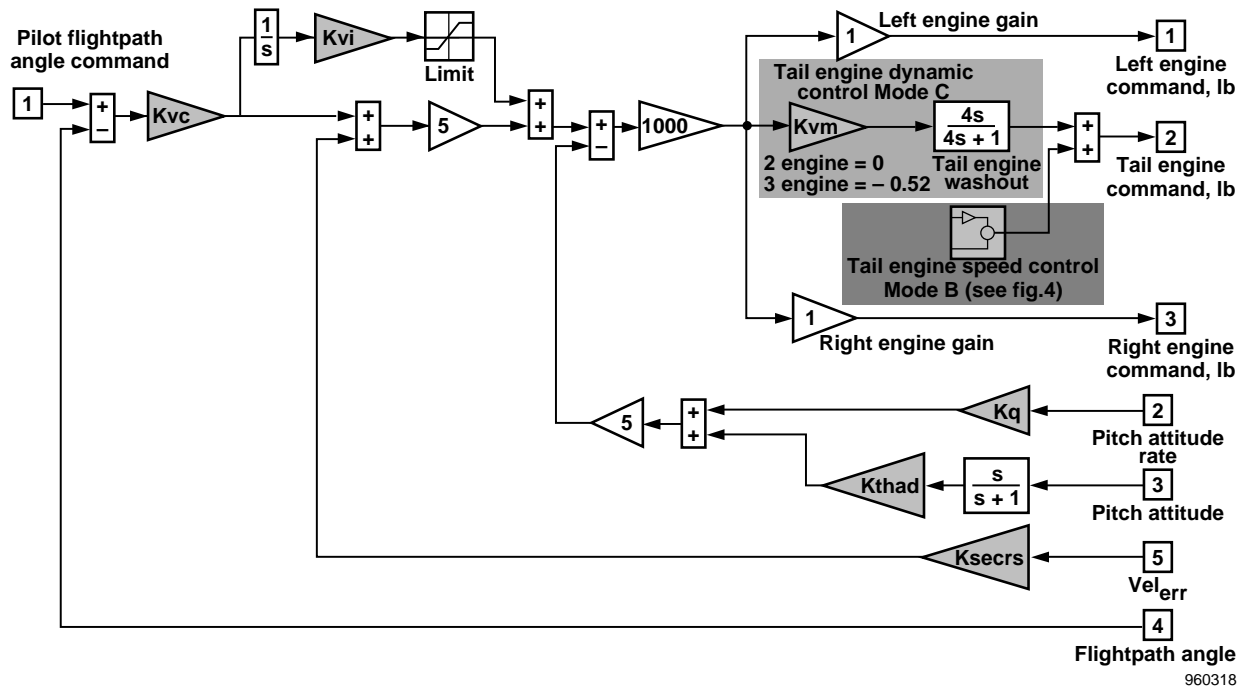

Figure 3. Longitudinal MD-11 PCA block diagram two- and three-engine control (modes A, B, and C).

Table 1. The PCA final flight control law gains for two- and three-engine operations.*

	K_{vc}	K_{vi}	K_q	K_{secs}	K_{thad}	K_{vm}
Mode A	1.20	0.14	1.42	0.04	1.60	0.00
Mode C	1.22	0.09	0.94	0.20	1.60	-0.52
ILS	1.20	0.00	4.00	0.04	0.00	-0.52

* Mode A (two-engine controller) uses the wing engines, mode C (three-engine controller) uses the wing and tail engines, and ILS (two- or three-engine mode) uses any mode (A, B, or C).

Tail Engine Speed Controller: PCA Mode B

The speed control system was designed to obtain manageable landing speeds (fig. 4). Simulation studies have shown that using the tail engine can change the airspeed by up to 40 kn. The airspeed can also be affected by other means, such as lowering the landing gear and changing the c.g. position.²¹ For this phase of the program, the tail engine was designed to work in conjunction with PCA mode A (wing-engines-only controller). The output of the speed controller (PCA

mode B) is summed just before the center engine command is sent to the FADEC (engine controller). (See dark gray box area in figure 3.) The PCA control mode B does not use the tail engine for dynamic control of flightpath angle tracking shown in table 1 are not changed when the speed controller is engaged.

Wing and Tail Engine Controller: PCA Mode C

The wing and the tail engines provide pitch control for PCA mode C. The tail engine gain, K_{vm} , was no longer zero and had an opposite sign associated with the commanded output because the center engine is approximately 20 ft above the c.g. and causes a strong nosedown pitching moment with thrust increase. (See light gray area in figure 3.) This gain is the opposite sign of the moments from the wing engines. This opposite pitching moment trend can be used favorably with a negative washout (high-pass) filter for added tracking control. If a positive pitching motion is commanded, the two wing engines would increase thrust; meanwhile, the tail engine would reduce thrust for a short time period. The resulting moment would be a nose-up motion. The center engine washout filter time constant is 4 sec. The result is a feed-forward controller that passes tail engine command transients and provides damping but washes out low-frequency command signals.

²¹John Feather, Drew Pappas, J. D. McDonnell, "Application of the Propulsion Controlled Aircraft (PCA) Flight Control System Concept to an MD-11 Aircraft," MDC 94k1262, McDonnell Douglas Aerospace, Long Beach, California, Jan. 1995.

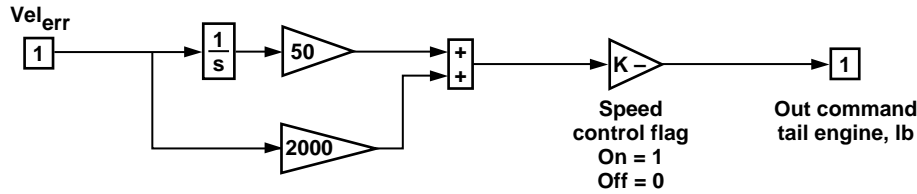

960319

Figure 4. The MD-11 tail engine speed control block diagram for mode B.

PCA ILS-Coupled Option

The ILS virtually eliminates pilot work load during landing by providing the flightpath angle command. This system was considered critical in meeting the minimal or no crew training objective. The PCA control law command was derived from the ILS receiver. Gain modifications were required to use the ILS generated flightpath angle command. One modification was to the integrator gain, K_{vi} , which was zeroed out during the ILS engagement. The reason for nullifying K_{vi} was that the ILS system integrates the error in glideslope before the PCA controller receives the signal, and the additional error integration was not necessary. The ILS-coupled mode worked in conjunction with any of the PCA modes (A, B, or C). A feature of the ILS-coupled mode is the flare logic which adjust flightpath angle command, γ_{cmd} , as a function of altitude above the runway. At 130 ft above the runway, the flightpath angle command became -1.5° until 30 ft above the runway where the command was set to approximately -0.7° . Table 1 lists the gains that were used for flight test. Note that the gains varied for the two- and three-engine and ILS PCA operations. The MD-11 airplane open-loop dynamics are given in the appendix.

Autothrottle Servocontroller: PCA Mode D

This mode could be easily implemented into the majority of autothrottle systems for longitudinal control and does not require changes to the FADEC system. The advantage of this mode is that the engines are driven by the automatic throttle servocommand, and the only change required to the FCC software is to provide for the controller and switching logic. However, a drawback to this method is that the pilot will need to close the loop for lateral-directional control using differential throttle inputs.

Figure 5 shows one possible system architecture used for closed-loop flightpath control. The design methodology was to assume all three engines were operational but to design the system with enough

robustness to allow for acceptable performance using only the wing engines. Analysis indicates that the response is better with wing engines only as opposed to all engines operating. The reduced response with all three engines is expected because the tail engine is above the c.g. and the autothrottle command cannot command the tail engine separately from the wing engines.

Simulation

Flight control system design and analysis for aircraft rely on mathematical models of the vehicle dynamics. These models are brought together to form a linear or nonlinear simulation. The development of the PCA control algorithms used a six-degree-of-freedom nonlinear simulation program and linearized state-space models for control law design.²⁴ In addition, a fixed-base, piloted, high-fidelity simulator was used. This simulator had an option to run hardware-in-the-loop FCC and FADEC.

For linear analysis and simulation, the engine thrust dynamics were modeled as a first-order Laplace transform shown in equation 1, with a rate limit of one-half the trim thrust output in pounds per second (eq. 2). Equation 3 shows the autothrottle servomodel.

$$eng(s) = \frac{1}{(0.5s + 1)} \quad (1)$$

$$Engine_{rate} = trim_{thrust}/2 \text{ lb/sec} \quad (2)$$

$$Throttle_{servo} = \frac{0.57}{(s + .57)} \quad (3)$$

Software Implementation

For flight-test demonstration, the PCA logic resides in only one of the two FCC for safety reasons. The FCC provides a host of functions including autopilot,

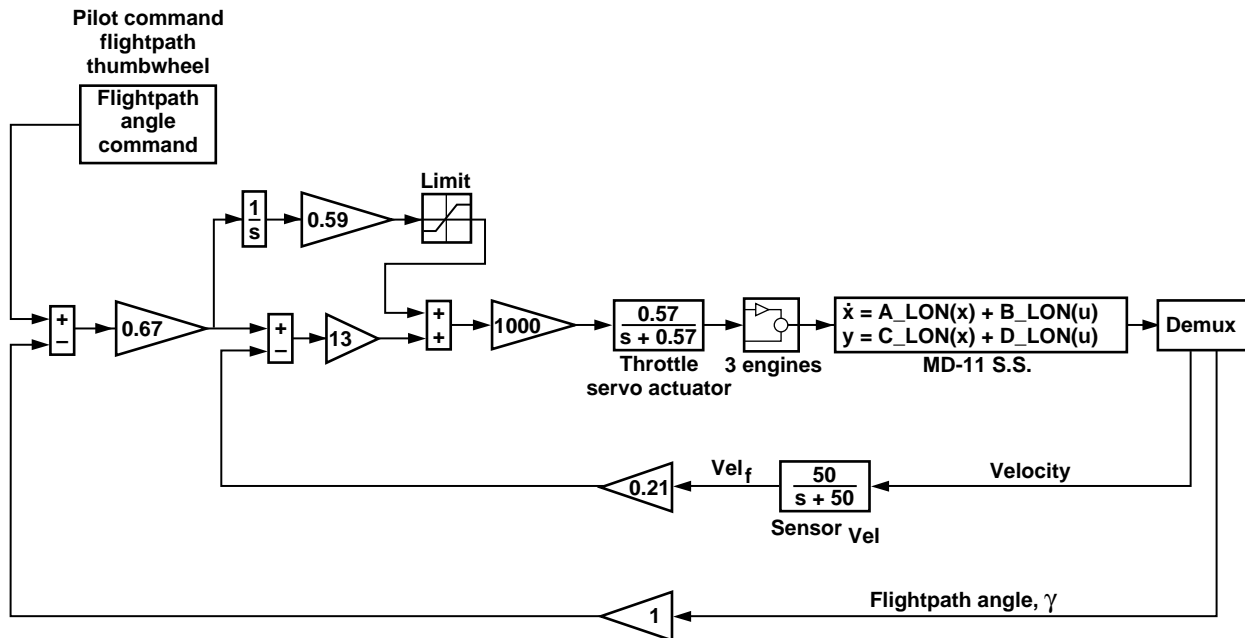

960320

Figure 5. The MD-11 PCA longitudinal block diagram (autothrottle control) mode D.

autothrottle, navigation, and flight management. The PCA logic interfaced to existing sensor signals and sent commands to the engine FADEC over a 429 data bus. The engine controllers were modified to accept a full-range EPR command from the FCC which ranged from 0.9 to approximately 1.5. The PCA system included safety disengage capabilities which were activated by the pilot through throttle lever movement or pressing a FCC switch. These features provided pilots with normal throttle and conventional control surface response, if needed.

Flight-Test Maneuvers

When the PCA system was engaged, the primary feedback paths were turned off (yaw damper and longitudinal stability augmentation system) which causes the surfaces to remain fixed in the absence of a direct pilot command. During PCA flight-test operations, the hydraulic system was powered for safety. These flight-test maneuvers were flown at the following conditions: with flaps set at 28° and with the landing gear down: 17,000 ft, 175 kn and 10,000 ft, 245 kn. The pilot stabilized the aircraft with the PCA system turned on and executed a series of flightpath angle and velocity command step inputs. Examples are presented in the Results and Discussion section.

Low approaches were performed in a graduated series of decreasing altitudes until the final touch downs occurred. In addition, two ILS-coupled landings using

PCA mode A were accomplished. In total, there were three PCA landings: two ILS landings and one piloted γ_{cmd} landing tasks^{2,7} without any aerodynamic control movement.

Note that the flaps were set at 28° (take-off flap position) to obtain low landing speeds. Other flight conditions were flown, such as the 0.0° flaps, a range of c.g. positions (23- to 31-percent mean aerodynamic chord), and the variations in altitudes and airspeeds.² Low approaches to 50 ft above the ground were flown with 0.0° flaps, landing gear down, and airspeed of approximately 195 kn. These cases were never allowed to touch down because of programmatic decisions and airplane rental agreements. Even though the 0.0° flap approach speeds would have been pushing the upper limitations of a “normal” MD-11 landing (204-kn tire speed), during an actual emergency, these conditions would be acceptable. The PCA flight characteristics with the flaps at 0.0° were well-behaved. No noticeable stability or performance degradation occurred. These results will not be presented in this report because all the landings were performed with 28° flaps.

Results and Discussion

This section presents the flight-test results for control modes A, B, and C. Also included is an ILS PCA landing using control mode A. Simulation results are presented for control mode D.

Wing-Engines-Only Controller: PCA Mode A

Figure 6 shows a longitudinal flightpath angle command step input with PCA mode A engaged at an altitude of 17,000 ft and a velocity of 169 kn. The flightpath angle command of -1° was held for 30 sec and then released. The maximum pitch attitude rate was approximately 0.22 deg/sec with a velocity change of 3 kn. The altitude was 17,050 ft at the beginning of the maneuver and 16,700 ft at the completion. The EPR traces for the left, tail, and right engines indicate the engine thrust levels. For this controller, the tail EPR level did not change; however, the left and right wing engine EPR's decreased and increased in conjunction with the commanded input. The pilots rated PCA control mode A as "good."

Tail Engine Speed Controller: PCA Mode B

Figure 7 shows the flight-test results of the PCA mode B with the initial conditions of an altitude of 10,000 ft and a velocity of 245 kn. With the PCA system commanding flightpath angle to zero, the pilot dialed in a speed change of 25 kn. It took approximately 60 sec for the airplane to reach 270 kn. The tail EPR went from 0.9 to a maximum of 1.13 before it settled down to 1.08. In addition, the flightpath angle and flightpath angle command traces where the flightpath error went almost to 1° with an altitude increase of 175 ft. The flightpath transient error of 1° is a considerable amount of overshoot; however, the steady-state flightpath error is small (0.05°). Part of the transient error is caused by the velocity error signal being feed back to the wing engines (fig. 3, mode A). Further improvements could be made by changing the control gain (K_{secs}).

Angle of attack, α , is an important parameter that gives insight to the speed control dynamics. The initial angle of attack was 4.2° at a velocity of 245 kn, and the final trim angle was 3.25° . As velocity increased, angle of attack decreased to maintain approximately the same initial lift as before the input while the PCA system was commanding zero flightpath angle. The pilots rated the speed control mode "good," and no further work was done on this system. This study demonstrated that speed control could be obtained from use of the center engine while holding nearly constant flightpath angle.

Wing and Tail Engine Controller: PCA Mode C

The PCA mode C takes advantage of all the engines to provide control of flightpath angle and airspeed and should ideally improve the PCA performance. Figure 8 shows a flightpath angle command step input at an altitude of 17,000 ft similar to the input performed with

the two-engine PCA mode A maneuver. The command of -1° was held for 30 sec before being released to zero. Comparing the flightpath angle of mode C with mode A (fig. 6) reveals that the control was "tighter" with mode C and resulted in less steady-state error. The maximum pitch attitude rate was approximately 0.38 deg/sec compared to 0.22 with mode A. Because of the additional control power provided by the tail engine, velocity had less variation with mode C with a change of only 1.3 kn compared to 3 kn with mode A. For this controller, the tail EPR changed during the maneuver. However, this change was in the opposite direction compared to the wing engines during the flightpath command onset of -1° and then back to 0° . This mode was never used for a landing because it would not show the generic two-engine PCA application. However, during an ILS-PCA approach to 50 ft, the pilot commented that "this was the best of all the modes flown yet; overall, very smooth approach."

ILS Landing Phase

A pilot-commanded PCA landing was performed before the ILS landing.^{2,7} The pilot commands the flightpath angle all the way to touch down with this mode without ILS. The flightpath angle command for the ILS-PCA-coupled landing is generated from the FCC and ILS localizer and the glideslope deviation signals.

Figure 9 shows the PCA-ILS landing time histories, simulating a total hydraulics pressure loss using only the wing engines for control (mode A). During the first 65 sec, the ILS-PCA system is commanding the flightpath angle command until 130 ft above the runway. Here, the first flare flightpath angle command of -1.5° is held until 30 ft above the ground (75 sec on fig. 9). The second flare command is approximately -0.75° and is held until touch down at 85 sec. The engine activity is small until the flare point as is shown in the EPR traces. Important factors in an aircraft landing are the sink rate, \dot{h} ; landing weight, and gear limitations. Sink rate is -10 ft/sec during the approach and flares out to a very smooth landing at -2 ft/sec. A "normal full-up system" MD-11 landing is considered good if the sink rate is less than 3 ft/sec with a maximum of 10 ft/sec. Radar altitude, speed, and control surface position traces for the landing are also shown. Note that the control surfaces were not moving (elevators, stabilizers, and ailerons). The PCA landing was well within the normal MD-11 airplane fully operational control system landing. The pilots rated the ILS-coupled system with mode A "very good." As a side note, the pilot-commanded PCA system (without ILS) was rated "good

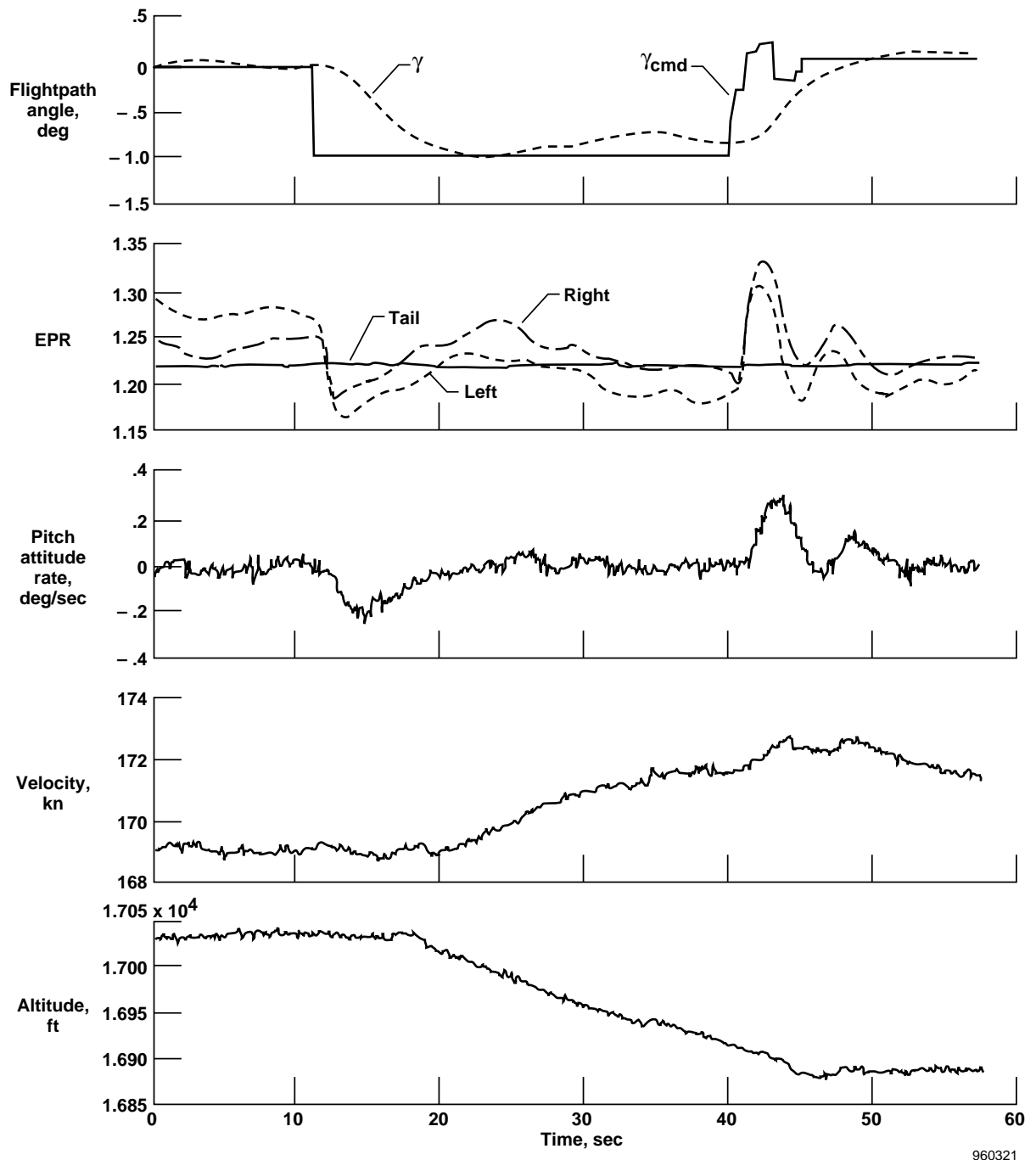

960321

Figure 6. Flight data of MD-11 wing engines PCA flightpath angle command step response, mode A.

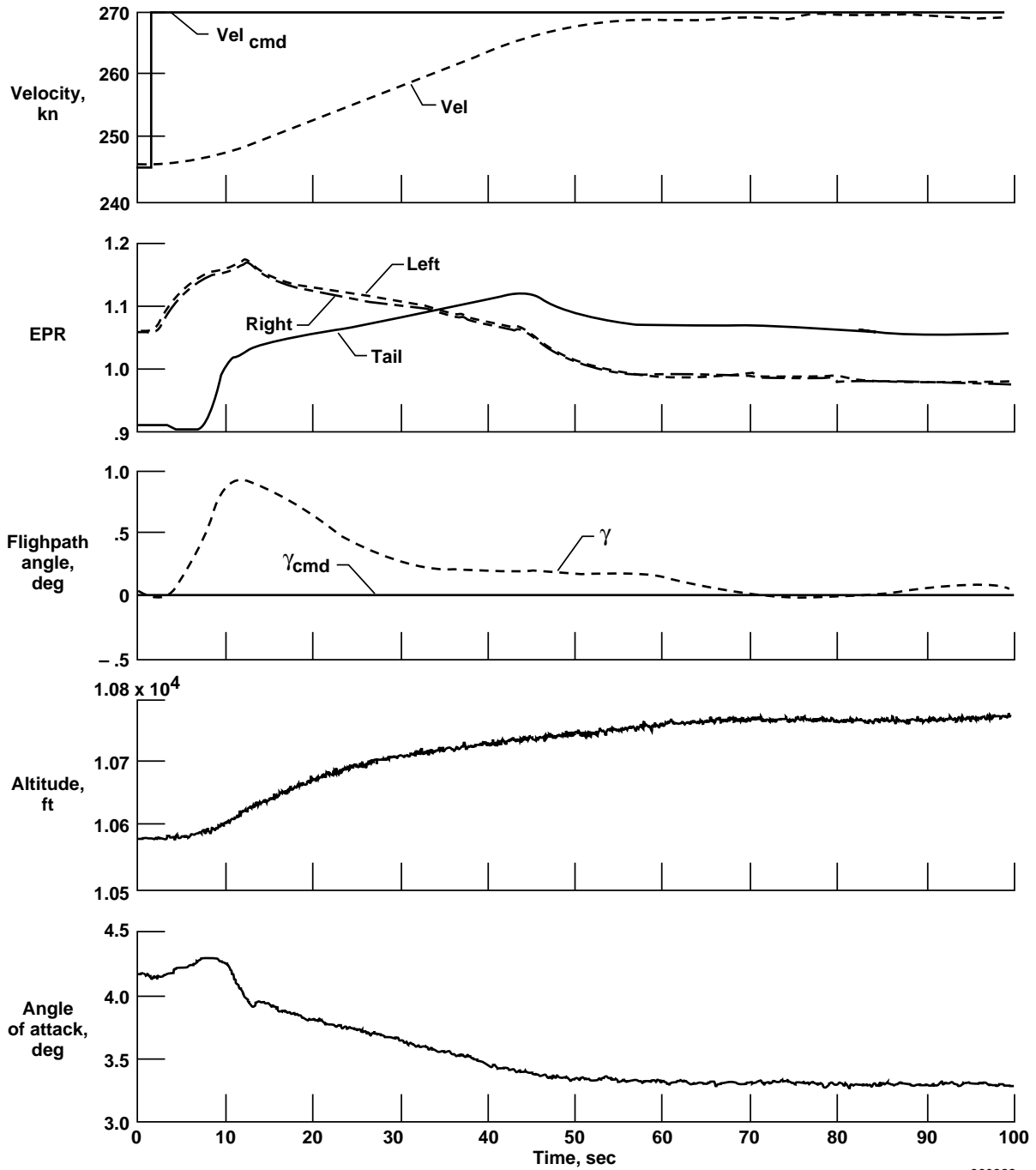

960322

Figure 7. Flight data MD-11 PCA speed control step response, mode B.

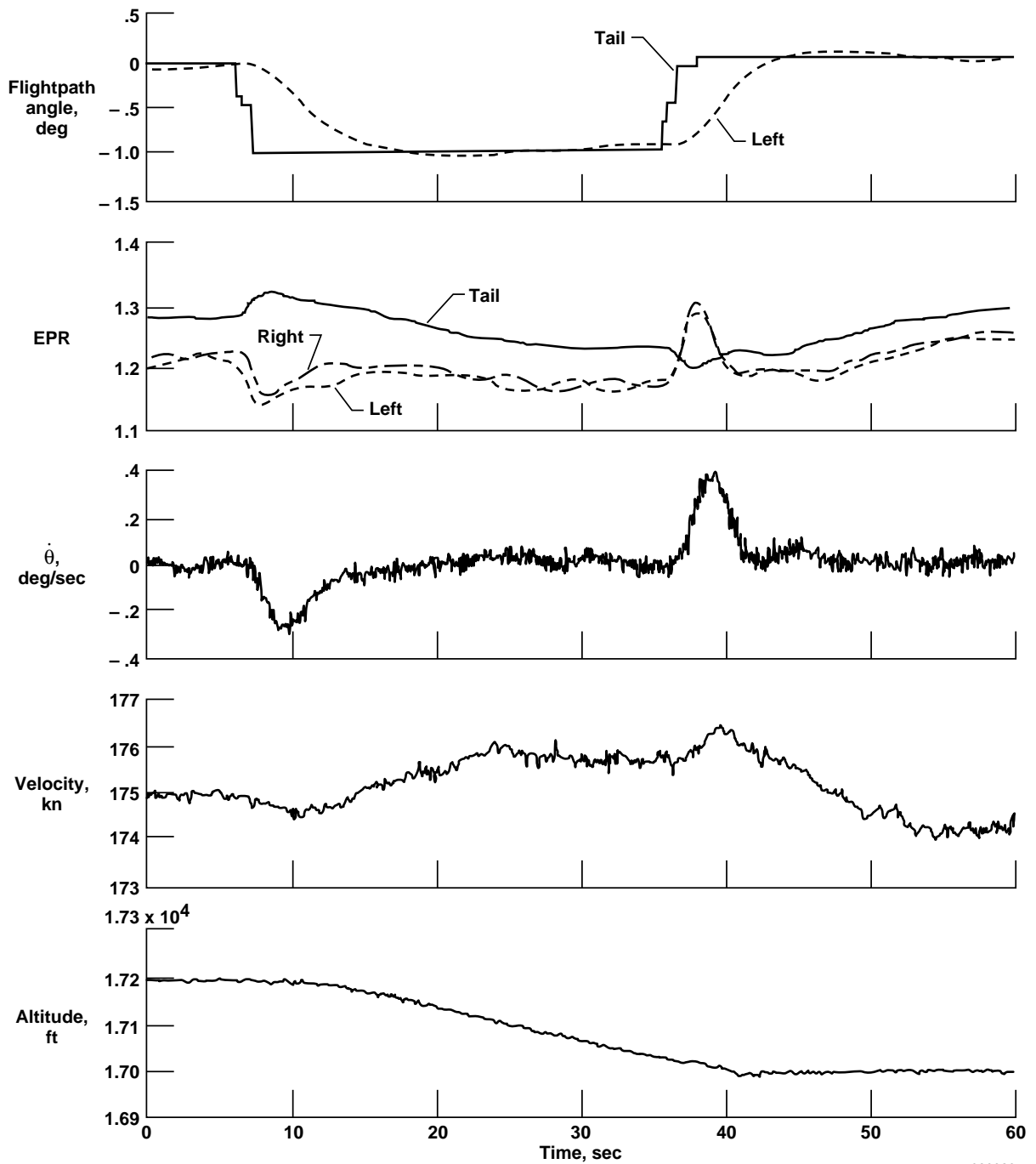

960323

Figure 8. Flight data MD-11 PCA flightpath step response, mode C.

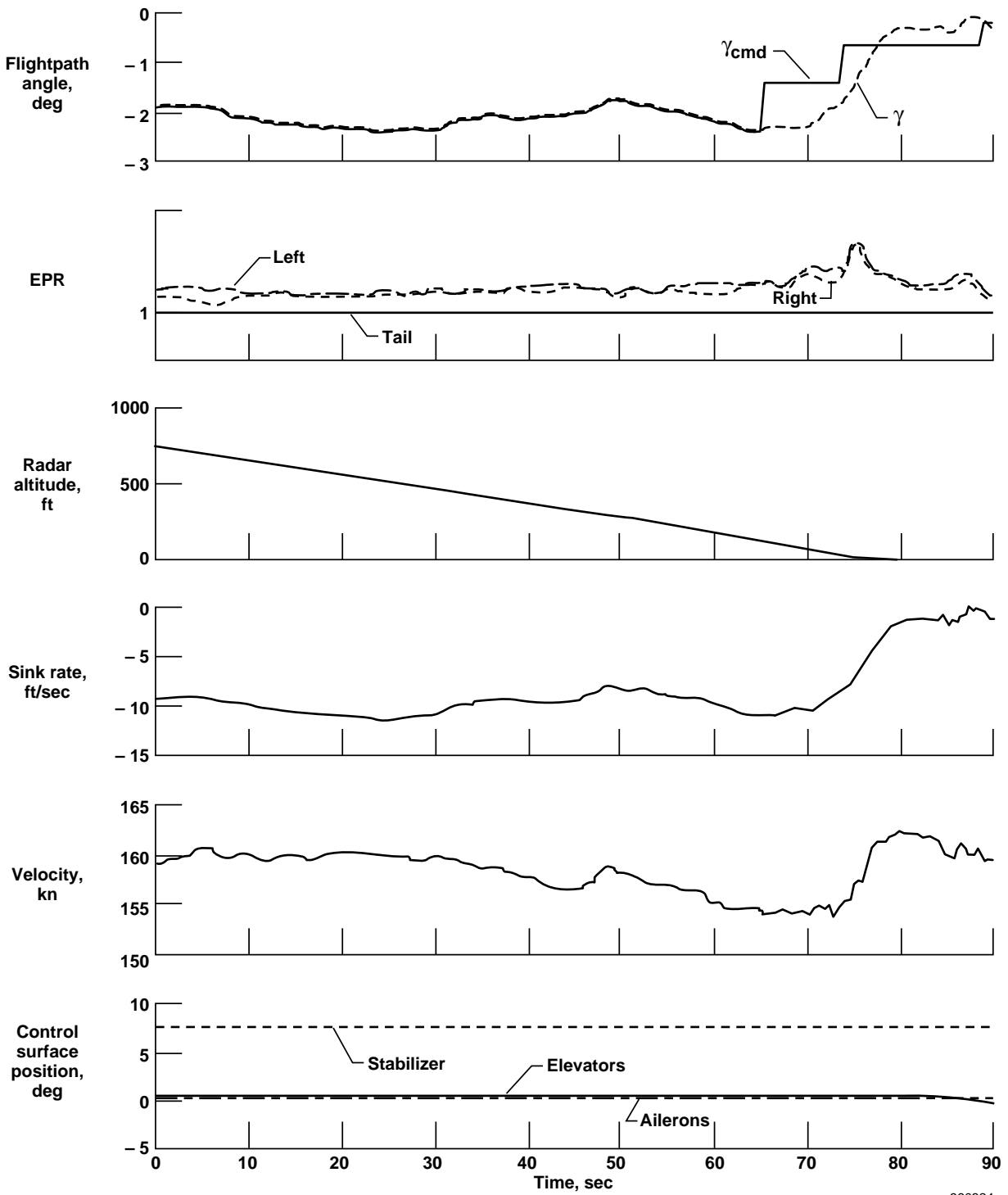

960324

Figure 9. The MD-11 PCA-ILS-coupled landing flight response flaps = 28°.

with some compensation needed in the lateral-directional axis due to the sluggish response in disturbance.”^{2,7}

Autothrottle Servocontroller: PCA Mode D

Figure 10 shows a simulation time history of a PCA controller using the autothrottles (mode D). These data indicate that it took 20 sec to reach the commanded input of 1°. This speed is slower than with modes A or C because the tail engine is producing a nosedown moment. Meanwhile, the wing engines are producing a nose-up moment which causes the slower response. Velocity increased approximately 2.5 kn then settled back to almost the initial speed with a pitch attitude rate of 0.1 deg/sec. The change in thrust levels for the left and tail engines are presented for the simulation engine activity. The change in the altitude trace shows constant climb for the 1° flightpath angle command. This controller was not flight tested but is presented because of the very simple nature of the design and implementation. Based on linear simulation results, this controller could be used to safely land the airplane while the pilot used differential throttle inputs for lateral-directional control.

Concluding Remarks

An emergency backup control system using engine thrust-only was designed and flight tested on a large, civil-transport airplane (MD-11). This report describes the longitudinal Propulsion-Controlled Aircraft (PCA) control systems and flight-test results for a wing engine controller for flightpath control, tail engine for speed control, and wing and tail engine controller for flightpath and speed control. Either the pilot-commanded track mode or the instrument landing system (ILS) PCA-coupled option for flightpath control could be used for modes A, B, or C.

A simplified automatic throttle PCA design for longitudinal control performed well, using both wing engines and even better using the wing and tail engines. An ILS-coupled landing using only the wing engines was also accomplished. The pilots rated the longitudinal characteristics as “very good.”

The PCA system has limited control power and may not be sufficient to handle surface hardovers or large mistrim configurations, but the backup control system has demonstrated the ability to safely land the airplane. Results show that the system could be used in an emergency event, such as an airplane suffering a major

primary control system failure, for example, a total hydraulic pressure loss. The PCA system changes a flight situation where there is an extremely high work load (using manual throttle inputs) to a viable piloting task. An alternate implementation using autothrottles was also presented as a simpler mechanization of the PCA concept.

APPENDIX

MD-11 PCA Plant Model (Altitude 12,000 ft and Velocity, 175 kn)

$$\dot{x}(t) = Ax(t) + Bu(t)$$

where $A = A_{lon}$

$$B = B_{lon}$$

$$y = Cx(t)$$

$$x_{lon} = [uu \ ww \ q \ \theta]^T$$

$$u = [\delta_{left \ eng} \ \delta_{tail \ eng} \ \delta_{right \ eng}]^T$$

Longitudinal dynamics:

$$A_{lon} = \begin{bmatrix} -2.115e-2 & 9.172e-2 & -3.753e-1 & -5.605e-1 \\ -1.347e-1 & -5.656e-1 & 5.927 & -3.333e-2 \\ 4.679e-3 & -6.454e-2 & -2.458e-1 & 0 \\ 0 & 0 & 1 & 0 \end{bmatrix}$$

$$B_{lon} = \begin{bmatrix} 9.153e-5 & 9.152e-5 & 9.133e-5 \\ 4.427e-6 & 1.371e-6 & -1.542e-6 \\ 2.962e-5 & -3.600e-5 & 1.895e-5 \\ 0 & 0 & 0 \end{bmatrix}$$

$$C_{lon} = \begin{bmatrix} 1 & 0 & 0 & 0 \\ 0 & 1 & 0 & 0 \\ 0 & 0 & 1 & 0 \\ 0 & 0 & 0 & 1 \end{bmatrix}$$

$$D_{lon} = \begin{bmatrix} 0 & 0 & 0 \\ 0 & 0 & 0 \\ 0 & 0 & 0 \\ 0 & 0 & 0 \end{bmatrix}$$

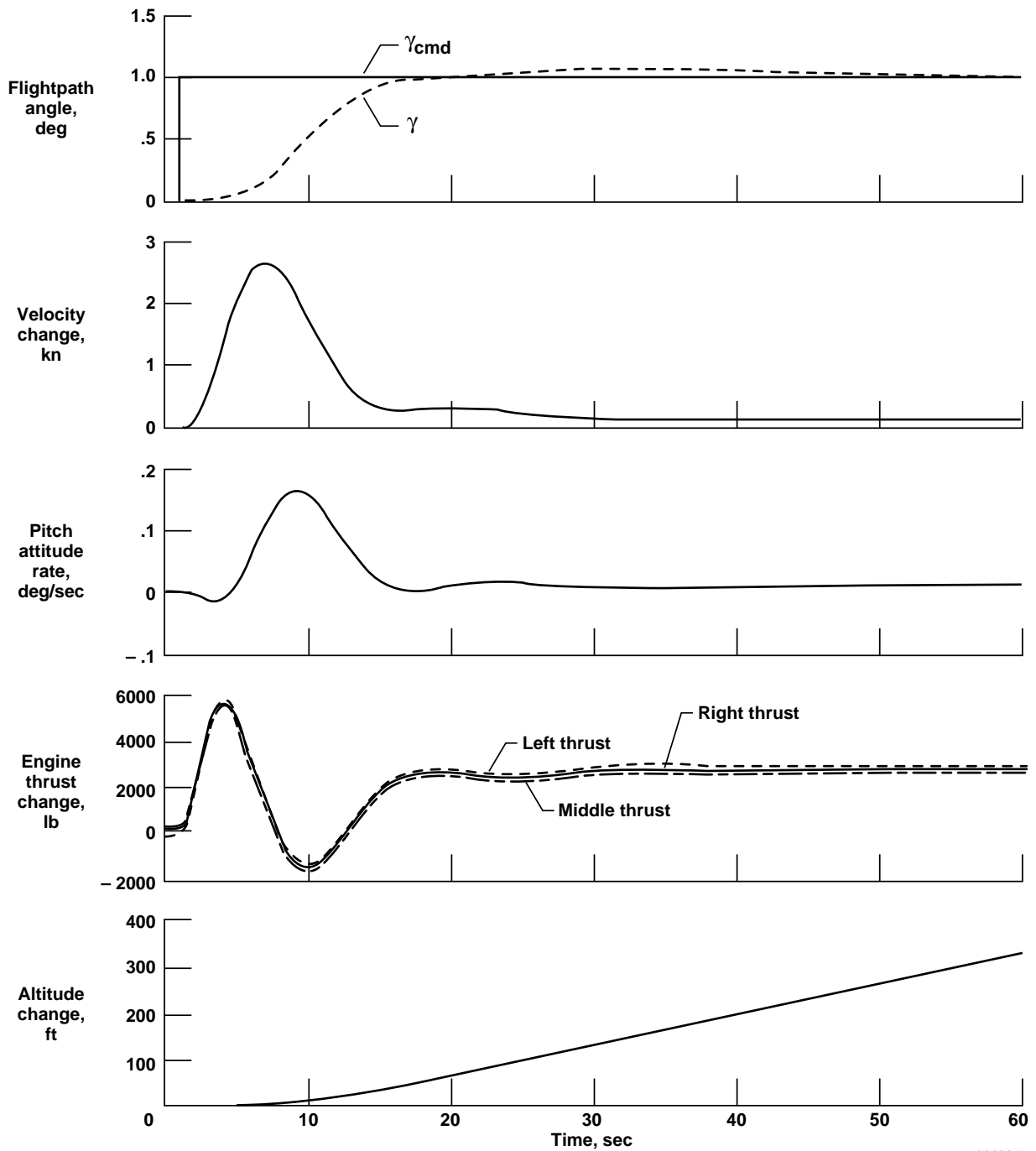

960325

Figure 10. The MD-11 PCA autothrottle system simulation step response, γ_{cmd}/γ , mode D.

References

¹Hughes, David and Michael A. Dornheim, "United DC-10 Crashes in Sioux City, Iowa," *Aviation Week & Space Technology*, July 24, 1989, p.p. 96–98.

²Burcham, Frank W., Jr., Trindel Maine, John J. Burken, and Drew Pappas, "Development and Flight Test of an Augmented Thrust-Only Flight Control System on an MD-11 Transport Airplane," AIAA 96-3742, July, 1996.

³Burcham, F. W., Jr., John Burken, and Trindel A. Maine, *Flight Testing a Propulsion-Controlled Aircraft Emergency Flight Control System on an F-15 Airplane*, NASA TM-4590, 1994.

⁴Burcham, Frank W., Jr., and C. Gordon Fullerton, *Controlling Crippled Aircraft—With Throttles*, NASA TM-104238, 1991.

⁵Gilyard, Glenn B., Joseph L. Conley, Jeanette Le, and Frank W. Burcham, Jr., *A Simulation Evaluation of a Four-Engine Jet Transport Using Engine Thrust Modulation for Flightpath Control*, NASA TM-4324, 1991.

⁶Burcham, Frank W., Jr., Trindel Maine, and Thomas Wolf, *Flight Testing and Simulation of an F-15 Airplane Using Throttles for Flight Control*, NASA TM-104255, 1992.

⁷Burken, John J., Frank W. Burcham, Jr., Trindel A. Maine, John Feather, Steven Goldthorpe, and Jeffrey Kahler, "Flight Test of a Propulsion-Based Emergency Control System on the MD-11 Airplane with Emphasis on the Lateral Axis," AIAA 96-3919, 1996.

REPORT DOCUMENTATION PAGE

Form Approved
OMB No. 0704-0188

Public reporting burden for this collection of information is estimated to average 1 hour per response, including the time for reviewing instructions, searching existing data sources, gathering and maintaining the data needed, and completing and reviewing the collection of information. Send comments regarding this burden estimate or any other aspect of this collection of information, including suggestions for reducing this burden, to Washington Headquarters Services, Directorate for Information Operations and Reports, 1215 Jefferson Davis Highway, Suite 1204, Arlington, VA 22202-4302, and to the Office of Management and Budget, Paperwork Reduction Project (0704-0188), Washington, DC 20503.

1. AGENCY USE ONLY (Leave blank)	2. REPORT DATE July 1996	3. REPORT TYPE AND DATES COVERED Technical Memorandum	
4. TITLE AND SUBTITLE Longitudinal Emergency Control System Using Thrust Modulation Demonstration on an MD-11 Airplane		5. FUNDING NUMBERS WU 505-64-10	
6. AUTHOR(S) John J. Burken, Trindel A. Maine, Frank W. Burcham, Jr., and Jeffery A. Kahler			
7. PERFORMING ORGANIZATION NAME(S) AND ADDRESS(ES) NASA Dryden Flight Research Center P.O. Box 273 Edwards, California 93523-0273		8. PERFORMING ORGANIZATION REPORT NUMBER H-2019	
9. SPONSORING/MONITORING AGENCY NAME(S) AND ADDRESS(ES) National Aeronautics and Space Administration Washington, DC 20546-0001		10. SPONSORING/MONITORING AGENCY REPORT NUMBER NASA TM-104318	
11. SUPPLEMENTARY NOTES Presented as AIAA 96-3062 at the 32nd AIAA/ASME/SAE/ASEE Joint Propulsion Conference, Lake Buena Vista, Florida, July 1-3, 1996, J.J. Burken, T.A. Maine, F.W. Burcham, Jr., NASA Dryden Flight Research Center, Edwards, CA; J.A. Kahler, Honeywell, Inc., Phoenix, AZ.			
12a. DISTRIBUTION/AVAILABILITY STATEMENT Unclassified—Unlimited Subject Category 08		12b. DISTRIBUTION CODE	
13. ABSTRACT (Maximum 200 words) This report describes how an MD-11 airplane landed using only thrust modulation, with the control surfaces locked. The propulsion-controlled aircraft system would be used if the aircraft suffered a major primary flight control system failure and lost most or all the hydraulics. The longitudinal and lateral-directional controllers were designed and flight tested, but only the longitudinal control of flightpath angle is addressed in this paper. A flight-test program was conducted to evaluate the aircraft's high-altitude flying characteristics and to demonstrate its capacity to perform safe landings. In addition, over 50 low approaches and three landings without the movement of any aerodynamic control surfaces were performed. The longitudinal control modes include wing engines only mode for flightpath control and a three-engine operation mode with speed control and dynamic control of the flightpath angle using the tail engine. These modes were flown in either a pilot-commanded mode or an instrument landing system coupled mode. Also included are the results of an analytical study of an autothrottle longitudinal controller designed to improve the phugoid damping. This mode requires the pilot to use differential throttles for lateral control.			
14. SUBJECT TERMS Control system failure; Hydraulic system failure; Longitudinal emergency controller using thrust; MD-11 airplane; Propulsion control		15. NUMBER OF PAGES 18	
		16. PRICE CODE AO3	
17. SECURITY CLASSIFICATION OF REPORT Unclassified	18. SECURITY CLASSIFICATION OF THIS PAGE Unclassified	19. SECURITY CLASSIFICATION OF ABSTRACT Unclassified	20. LIMITATION OF ABSTRACT Unlimited