

IPCBS

High Performance Commercial Building Systems

Final Report on Internet Addressable Light Switch

Francis Rubinstein

Ernest Orlando Lawrence Berkeley National Laboratory

Peter Pettler

Vistron LLC

August 27, 2001



DISCLAIMER

This document was prepared as an account of work sponsored by the United States Government. While this document is believed to contain correct information, neither the United States Government nor any agency thereof, nor The Regents of the University of California, nor any of their employees, makes any warranty, express or implied, or assumes any legal responsibility for the accuracy, completeness, or usefulness of any information, apparatus, product, or process disclosed, or represents that its use would not infringe privately owned rights. Reference herein to any specific commercial product, process, or service by its trade name, trademark, manufacturer, or otherwise, does not necessarily constitute or imply its endorsement, recommendation, or favoring by the United States Government or any agency thereof, or The Regents of the University of California. The views and opinions of authors expressed herein do not necessarily state or reflect those of the United States Government or any agency thereof, or The Regents of the University of California.

This report was prepared as a result of work sponsored by the California Energy Commission (Commission). It does not necessarily represent the views of the Commission, its employees, contractors, and subcontractors make no warranty, express or implied, and assume no legal liability for the information in this report; nor does any party represent that the use of this information will not infringe upon privately owned rights. This report has not been approved or disapproved by the Commission nor has the Commission passed upon the accuracy or adequacy of the information in this report.

Ernest Orlando Lawrence Berkeley National Laboratory
is an equal opportunity employer.

Final Report on Internet Addressable Light Switch

Element 3—Lighting, Envelopes, and Daylighting

Task 2.1.2—Title 24 Wall Switch, Draft Final Report

**Francis Rubinstein
Building Technologies Department
Environmental Energy Technologies Division
Ernest Orlando Lawrence Berkeley National Laboratory
University of California
1 Cyclotron Road
Berkeley, California 94720**

**Peter Pettler
Vistron LLC
329 Bridge Way
Nevada City, California 95959**

August 27, 2001

This work was supported by the California Energy Commission through its Public Interest Energy Research Program and also by the Assistant Secretary for Energy Efficiency and Renewable Energy, Office of Building Technology, State and Community Programs, Office of Building Research and Standards of the U.S. Department of Energy under Contract No. DE-AC03-76SF00098.

Final Report on Internet Addressable Light Switch

Element 3—Lighting, Envelopes, and Daylighting

Task 2.1.2—Title 24 Wall Switch, Draft Final Report

Francis Rubinstein* and Peter Pettler**

Executive Summary

This report describes the work performed to develop and test a new switching system and communications network that is useful for economically switching lighting circuits in existing commercial buildings. The first section of the report provides the general background of the IBECS (Integrated Building Environmental Communications System) research and development work as well as the context for the development of the new switching system. The research and development effort that went into producing the first proof-of-concept (the IBECS Addressable Power Switch or APS) and the physical prototype of that concept is detailed in the second section. In the third section of the report, we detail the refined Powerline Carrier Based IBECS Title 24 Wall Switch system that evolved from the APS prototype. The refined system provided a path for installing IBECS switching technology in existing buildings that may not be already wired for light level switching control. The final section of the report describes the performance of the IBECS Title 24 Switch system as applied to a small demonstration in two offices at LBNL's Building 90. We learned that the new Powerline Carrier control systems (A-10 technology) that have evolved from the early X-10 systems have solved most of the noise problems that dogged the successful application of X-10 technologies in commercial buildings. We found that the new A-10 powerline carrier control technology can be reliable and effective for switching lighting circuits even in electrically noisy office environments like LBNL. Thus we successfully completed the task objectives by designing, building and demonstrating a new switching system that can provide multiple levels of light which can be triggered either from specially designed wall switches or from a digital communications network. By applying commercially available powerline carrier based technologies that communicate over the in-place lighting wiring system, this type of control can be economically installed even in existing buildings that were not wired for dual-level lighting. Final Report on Internet Addressable Light Switch

Introduction

This report describes the work performed to develop and test a new switching system that is useful for economically switching lighting circuits in existing commercial buildings. The first portion of the report provides the general background of the IBECS research and development work as well as the context for the development of the new switching system. The research and development effort that went into producing the first proof-of-concept (the IBECS Addressable Power Switch or APS) and the physical prototype of that concept is detailed in the second section. In the third section of the report, we detail the refined IBECS Title 24 Wall Switch system that evolved from the APS prototype described in Section 2. The fourth section describes the performance of the IBECS Title 24 Switch system as applied to a small demonstration in two offices at LBNL's Building 90. The appendix of the report provides the technical specifications for the key electronic components used in the Title 24 Switch.

Background

Lighting controls companies have developed controls products that can be specified as systems to achieve simple lighting control functions in buildings. Research conducted by LBNL in the late-1990s

* Francis Rubinstein is a Staff Scientist in the Building Technologies Department at Lawrence Berkeley National Laboratory in Berkeley, California.

** Peter Pettler is President of Vistron LLC in Nevada City, California.

demonstrated that components from different manufacturers could be specified, assembled as systems and installed in buildings to achieve simple lighting control functions and obtain significant energy savings. However, poor hardware and software functionality as well as failure to involve the occupants in the commissioning process resulted in low occupant acceptance of more advanced lighting control strategies such as daylighting.

To address the above market shortcomings, the overall technical goal of the Lighting/Daylighting and Envelope Element (Element 3) of the HPCB Program is to develop an integrated building equipment communications (IBECS) network that will allow appropriate automation of lighting and envelope systems to increase energy efficiency, improve building performance, and enhance occupant experience in the space. This network will provide a low-cost means for occupants to control local lighting and window systems, thereby improving occupant comfort, satisfaction and performance. A related goal of this program element is to improve existing lighting control components and accelerate development of new daylighting technologies that will allow daylighting to be more extensively applied to a larger proportion of building floor space.

The objective of this project is to design, build, and test the IBECS interface and networking system between controllable lighting devices that will enable local and system-wide energy-efficient operations of various lighting systems and components. Additional work includes developing working prototypes of advanced multi-functional sensors and power-metering devices.

Development of Title 24 Switch Proof-of-Concept

The thrust of the first year's work on the High Performance Commercial Buildings Program with respect to IBECS Project was the design, development and testing of an advanced light switch that would provide the user with additional lighting control capabilities while providing the building operator with a means to reduce lighting loads throughout a complex from a central location. The objective of this task is to design and fabricate an IBECS-ready wall switch. This switch would fit in a standard wall box, provide bi-level switch control (be compliant with California's Revised Title 24 requirements) and would be controllable (addressable) via IBECS (Integrated Building Environmental Communications System).

Initially, the general specifications for the switch proof-of-concept were as follows (more detailed technical specifications follow). In the refined switch discussed in Section 3, we developed additional specifications that would improve the usability of the switch in retrofit applications.

Initial Switch Specifications:

1. Switch must be a direct replacement for an existing wall switch.
2. Switch must be capable of switching at least two lighting switch circuits in order that the occupant be able to obtain more than just one level of light.
3. Switch must be capable of being switched remotely over a digital network (IBECS)

We completed the initial proof-of-concept for the IBECS-ready wall switch in February 2001 ahead of schedule. The proof-of-concept was in the form of circuit diagrams (**Figures 2 and 3**) specifying exactly what electronic components were necessary to achieve the switch functionality as indicated by the above specifications. In addition, Pete Pettler, our main subcontractor on this task, constructed a physical prototype of the IBECS addressable power switch (**Figure 1**) embodying the proof-of-concept circuit.



Figure 1. First prototype of the Title 24 wall switch built according to original specifications.

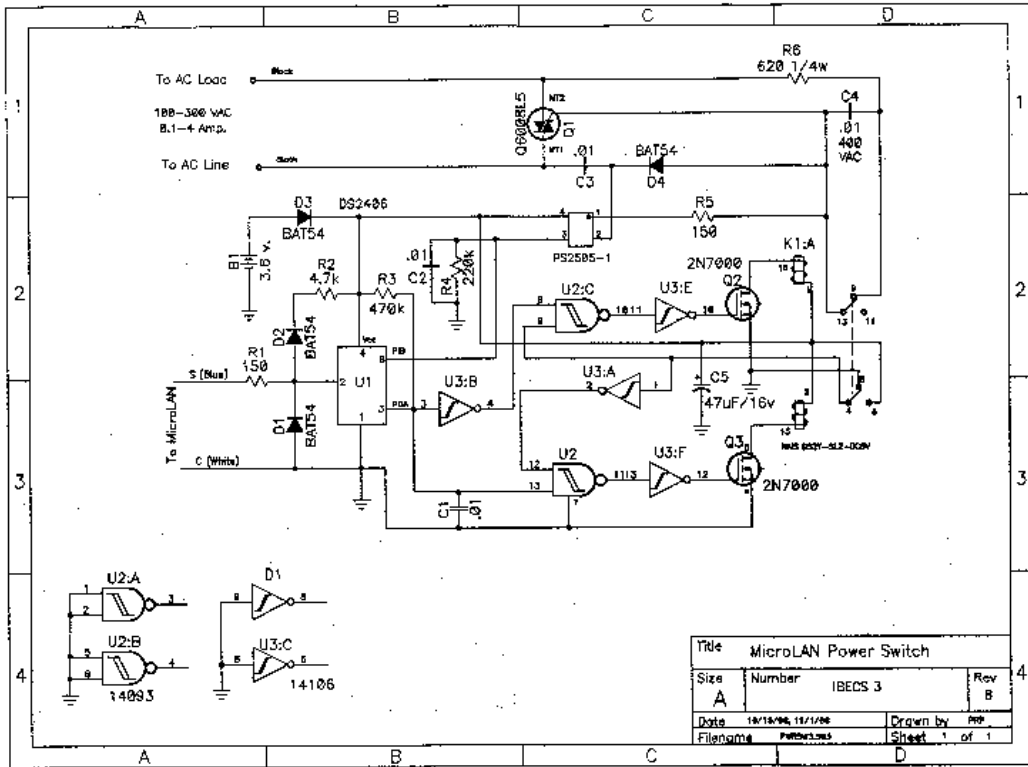

Figure 2. Original circuit diagram for the Title 24 switch proof-of-concept—microLAN Power Switch—showing the various components.

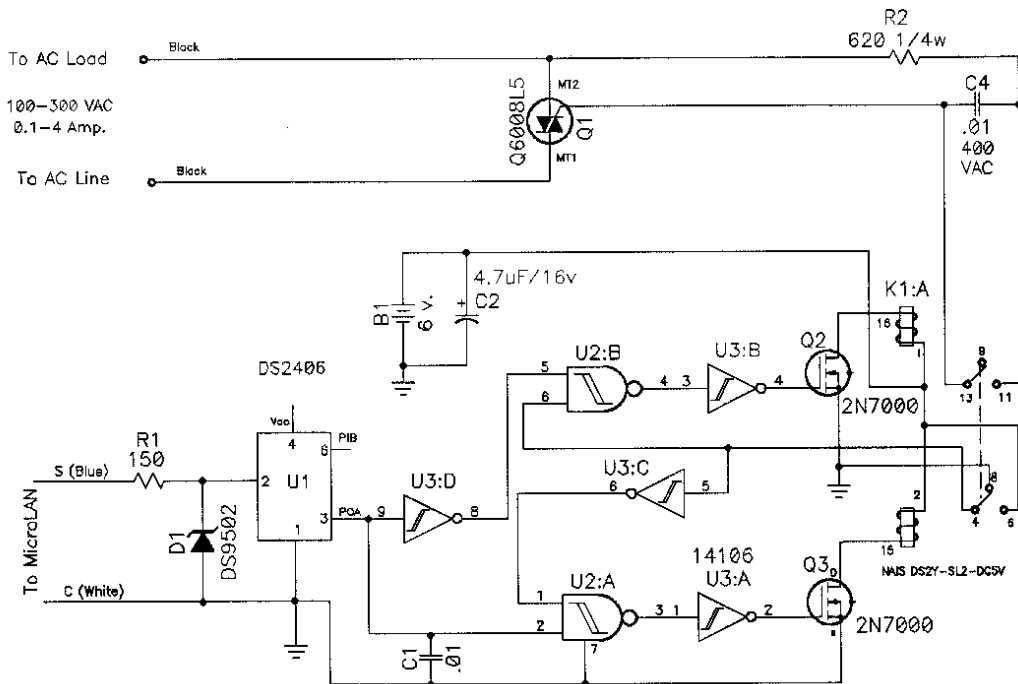

Figure 3. A higher resolution image of the circuit diagram shown in Figure 2 showing additional details and components.

The IBECS Addressable Power Switch (APS) serves as a slave AC contactor, which can be controlled by commands communicated to it over a 1-wire building automation network. In addition to ON-OFF control of lighting loads, it should also have wide Building Automation application for control of HVAC equipment and other mechanical systems. Because of the perceived relative importance of this function in the IBECS system implementation, the design of an Addressable Switch module was given priority in our development schedule.

We originally concluded that a commercially viable APS design would either have to default to a “closed” state during a network interruption or would have to retain its last command state until network integrity was restored. No commercially available product was located with this feature. The ability to perform load confirmation was also deemed to be very desirable. Both design objectives appear to have been attained. Some of the elements developed for this module will also serve as important constituents of the “Title 24 Wall Switch” scheduled to be designed later in this program.

APS Module Features:

1. Self-powered operation
2. Non-volatile memory retains last command state during temporary network outages
3. The flow of current into the load is confirmed to the host
4. Solid state switching element will reliably accommodate high inrush currents
5. Can be configured in a wide range of load ratings
6. Small physical size will fit into standard junction box wiring practices
7. Requires only a two-wire connection to the line and switched load
8. Can be configured in either single-, dual-, or 3-phase versions
9. Modest (1 watt per amp, typical) heat dissipation

Circuit Description

The simplified block diagram below (**Figure 4**) illustrates the interaction of the functional blocks within the APS. The Dallas Semiconductor DS2406 integrated circuit provides the interface to the 1-wire network. Here, one of its two ports is configured as an output, which sends a logic signal representing to the pulse steering circuitry reflecting the state of the most recent ON-OFF command. The second (“B”) port of the DS-2406 is used as an input, which monitors a signal from the Triac power switch. This signal indicates the flow of A.C. current into the load. The DS-2406 chip also includes a 1k bit non-volatile memory that is can be used during the commissioning process to store a short plain text identification of the controlled load.

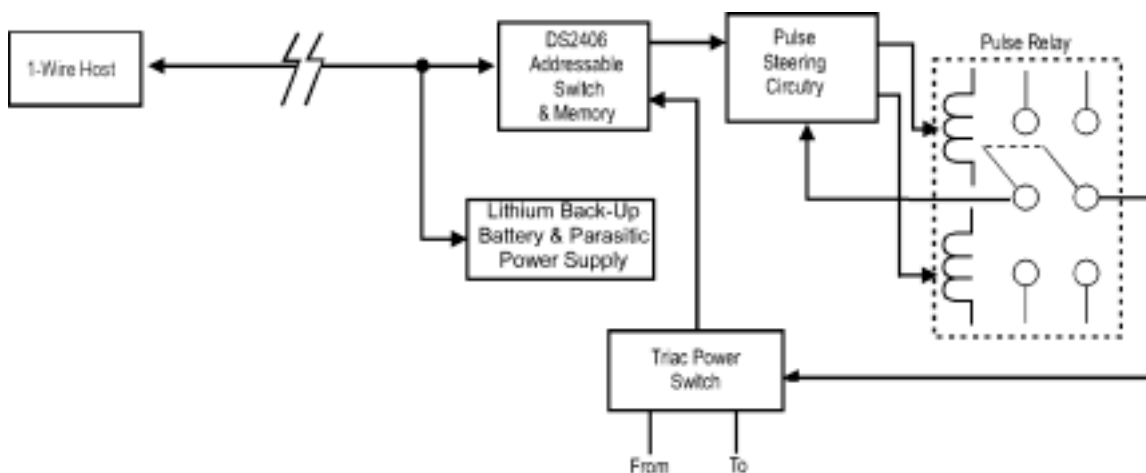

Figure 4. Simplified block diagram illustrating the functional blocks with the Addressable Power Switch (APS).

The pulse steering circuitry compares the state of the relay with the last ON-OFF command. This circuitry only energizes one of the relay coils whenever a change of command state is sensed. Because of the feedback arrangement, the circuitry maintains the relay drive current only long enough to complete the required change of state. This feature minimizes the energy used by the relay, while automatically adapting to changes in the relay pull-in time over changes in ambient temperature, etc.

The use of a pulse relay in the design of our module has a historical precedent from the ubiquitous General Electric RR-7, which has been widely employed in building lighting control. In our case, the pulse relay is a miniature signal relay having a DPDT contact arrangement. It requires an approximate 10-millisecond, 70-milliamp pulse from the 5-volt power supply (1.9×10^{-4} milliamp-hours) to change state. In this application, the pulse relay contacts carry only a very small current that is an order of magnitude below their ratings. Commercially available relays suitable for this application are widely used in telecommunications equipment and have a rated MTBF of 1 million operations.

The power switch utilizes a solid-state Alternistor Triac to control flow of current to the load. This type of Triac is commercially available in ratings from 6 to 40 Amps at ratings of up to 800 volts. They will reliably switch inductive loads and will tolerate the high inrush currents, which are typical with lamp ballasts. Included in the Triac interface is circuitry, which generates an isolated logic signal that confirms the flow load current. This scheme is extremely cost-effective, taking advantage of the inherent transfer characteristics of the Alternistor to sense the passage of load current.

The APS incorporates a power supply that derives energy both parasitically from the 1-wire buss and from an internal back-up lithium battery. By employing this dual arrangement the battery lifetime should exceed twenty years under normal usage.

Competitive Products

The only commercial product which has been located to perform power switching on a 1-wire network is offered as the Model T1R by Point Six, Inc. of Lexington, KY. Their unit uses an electromechanical relay, which requires a local isolated D.C. power supply, poorly tolerates high inrush currents and does not incorporate load current sensing. Their unit is priced at \$25.00 each. The physical size of the Point Six unit (excluding a power supply) is approximately the same as the 1" x 1" x 2" overall package (approximately 3 in³ volume) used to house the engineering model of the IBECS version (see **Figure 1**).

Estimated APS Cost

In 1000-unit production quantities we estimate the APS material and assembly labor costs are estimated to total approximately \$8.30 per unit.

Design Propriety

Two aspects of the APS design, as detailed in the attached schematic diagram, appear to be unique. The first apparently distinctive feature is the combination of the pulse steering circuitry used in conjunction with the latching relay. The special virtue of this feedback arrangement is that it minimizes the energy consumed by the relay to affect a change of state of its contacts over variations in temperature and supply voltage.

The second apparently unique feature involves the circuitry used to sense when load current is flowing. This is achieved by monitoring the AC voltage potential of approximately 0.7-volt peak, which appears between the MT1 and gate terminals of the Alternistor Triac whenever it is conducting current through the switched load. By employing a rectifying voltage doubler, we are able to derive sufficient drive from this low impedance source to provide adequate drive for an isolating LED-based optical coupler.

The author has not found any prior art that duplicates either of these cited arrangements. As such, it may be appropriate to file disclosure briefs for them. Otherwise, it may be desirable to publicize these designs to assure that they can have unencumbered commercial application.

Design Status

The APS design, as documented in the above schematic is a preliminary engineering version, requiring additional verification and review. As a part of that process, we have prepared a printed circuit implementation of the design, which can be subject to more rigorous laboratory testing and some appropriate field trials.

Development of the Refined Title 24 Switch System

Although the above proof-of-concept prototype met the letter of the scope of work, we elected in March 2001 to enhance the capabilities of the switch so that it could replace a standard single wall switch and control fixture-mounted relays over the existing switchleg using powerline carrier control. In other words, we expanded the capabilities of the Title 24 proof-of-concept so that it became a switch that could control individual fixtures even in spaces where bi-level circuiting was not in place. This ambitious expansion in the scope of work was only possible without an increase in budget because we identified that there were off-the-shelf powerline carrier (PLC) components that could provide the desired capabilities without having to perform additional R&D. (Technically, these components use a PLC protocol called A-10. A-10 is a successor to X-10 control, which has been used for many years for simple powerline control in residential buildings. X-10 is not adequate for controlling loads in commercial buildings because of electrical noise in the buildings).

Although this change in scope delayed the completion of this report deliverable, we thought that it was an acceptable trade-off since it would greatly increase the applicability of the IBECS Title 24 switch to existing spaces that, unfortunately, often do not have bi-level switch circuits in place.

Pettler identified powerline carrier control hardware designed for lighting systems that was commercially available. One company in particular, ACT, offers a line of such control products and also maintains an active testing program to qualify lighting ballasts that are “powerline friendly.” This company and technical specifications for the specific products used to assemble the demonstration system at LBNL is discussed in more detail in the Appendix A to this report. Note the selection of this company’s hardware to construct the demonstration does not imply that there are not other companies that have similar products and capabilities.

Demonstration of the Refined Title 24 Switch System at LBNL Offices

To test the PLC Title 24 switch concept just described, we coupled our initial Title 24 switch proof-of-concept with off-the-shelf PLC controllable relays, transceivers and other devices available from ACT and installed the system in two offices at LBNL in June. Neither of these offices had bi-level switching in-place so they were good candidates for testing the PLC Title 24 switch concept. Additionally, the two offices, though close by, are actually on two different branch circuits so we could test whether the A10 commands could successfully traverse across branch circuits. Finally, the electrical system at LBNL is old and has been modified several times over the years. Thus the test site at LBNL was a realistic one. Pete Pettler supervised the installation of the system, which was performed by LBNL’s Plant Maintenance personnel.

Figure 5 below shows how the PLC system was installed at the LBNL test site. The electrician replaced the existing standard wall switches in FR’s and JJ’s office with two-button wall-mounted transmitters (ACT Part TK324). Powerline carrier relays, called Feed Thru Relay Fixture Receivers (ACT Part RF304), were connected upstream of each of the fixture ballasts (2 in JJ’s office, 3 in FR’s office). The PLC system was electrically connected to the building lighting electrical distribution system through a transformer (ACT Part AF300 Filter/Transformer) at Branch Circuit #14 which provides lighting power to the lights in Judy’s (and neighboring) office. The transformer is in turn connected to a PLC transceiver (ACT Part TU 202 Transceiver), which is connected to a dedicated PC through the PC’s serial port (COM1). To keep costs down, an old PC running Windows 98 was used for the PC server. The operation of each of the major system components and necessary software is detailed below.

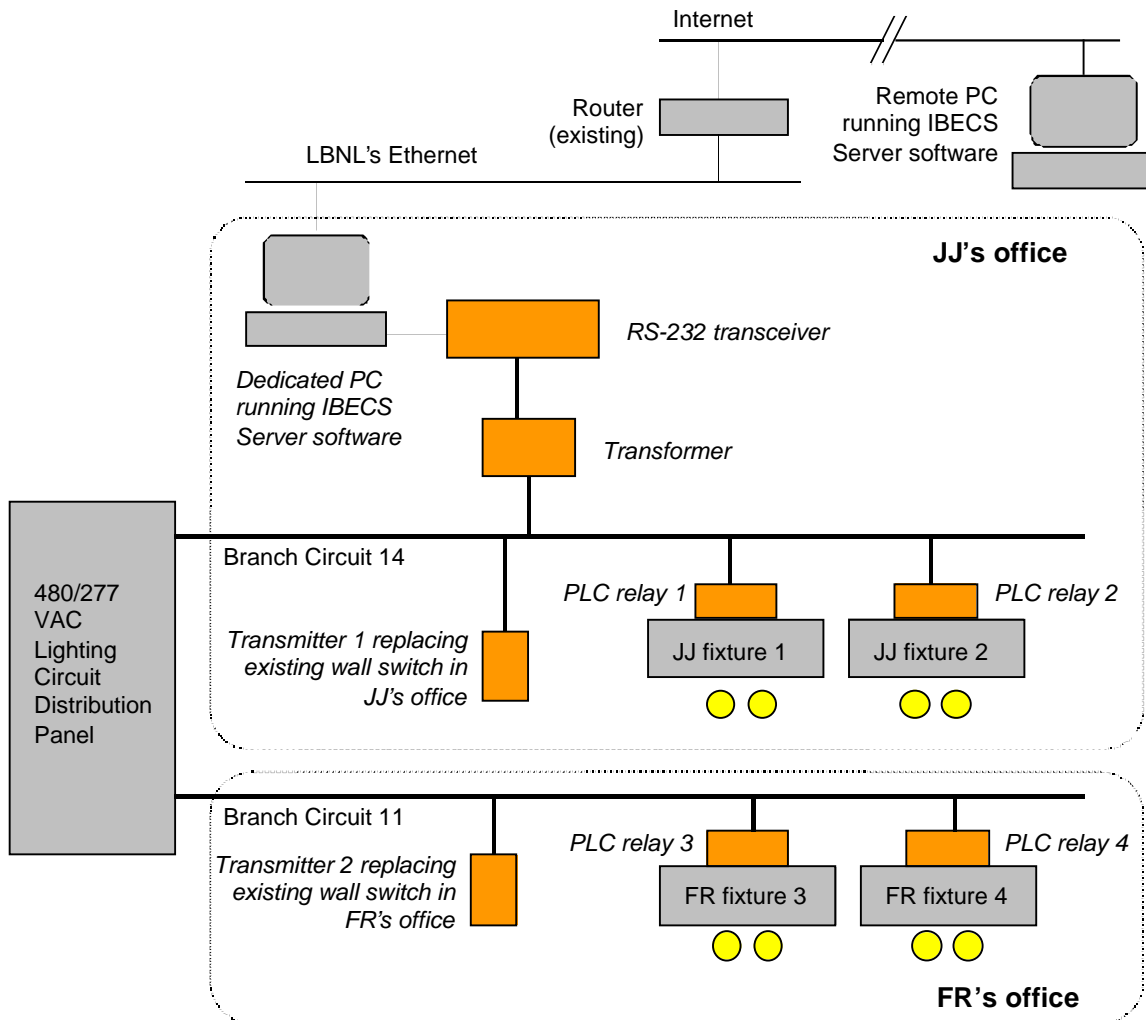

Figure 5. Diagram showing the Powerline Carrier Controlled Title 24 Switch system installed in the two offices at Building 90 at LBNL. The demonstration components are shown in orange.

Dedicated Server

A recycled PC was utilized to operate as a 24/7 host for the system. It was provisioned with TCP/IP access via the LBNL Ethernet LAN. It uses a single Com Port for bi-directional data communication with the PLC transceiver network. Microsoft Windows 98 was utilized as the operating system. Automated scheduling and lighting control routines are performed with a beta version of a real-time IBECS program (called IBECS Server) provided by Smart Buildings Technology Inc. of Lindenwold, N.J. This program performs condition-dependent, time-based scheduling with English-like scripts incorporating powerful IF, AND, OR logical conditional statements. The simple script that is used to control the lights in the offices at Building 90 is given in the Appendix B.

The inclusion of Ethernet/dial-up connectivity permits the remote downloading of program revisions as well a means of accepting control commands or for viewing system status from any authorized workstation connected to the Internet. Since the IBECS Server software is browser-based it is easy to provide a graphical user interface with self-descriptive icons that can run on most web browsers (i.e., Internet Explorer or Netscape Navigator). Future versions of this software will even include provisions for communicating with the host via cellphones or Personal Digital Assistants (PDAs) equipped with the Wireless Access Protocol (WAP). Below (**Figure 6**) is a screen shot taken from the IBECS Sever software from the PC showing the different components of the demonstration system setup at LBNL

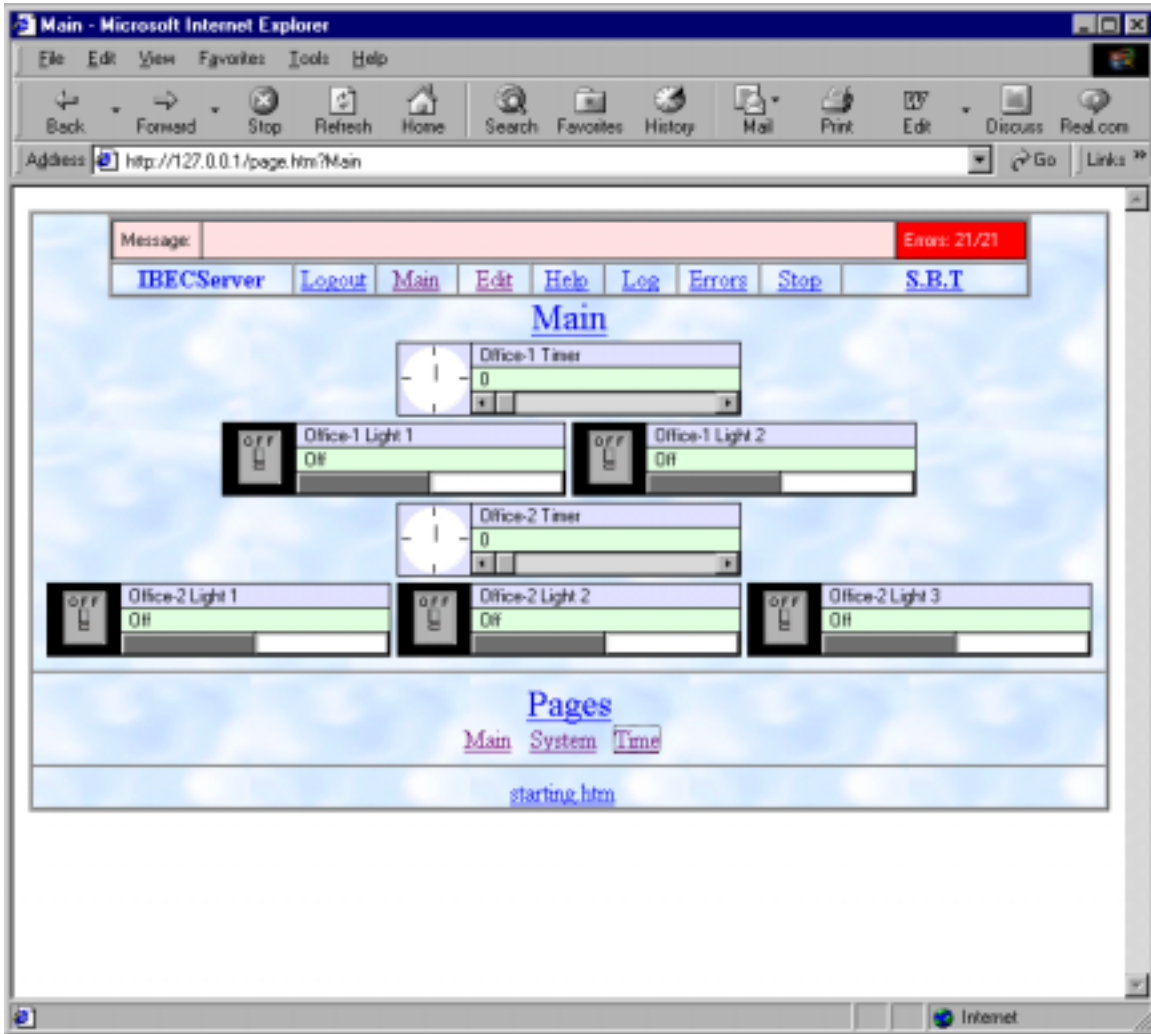

Figure 6. Screen shot from the PC running the IBECServer software that controls the lights in the demonstration system at LBNL.

RS-232/ RS-485 Converter

A planned future elaboration of the system dictated that the host computer be capable of communicating with both the PLC lighting network and a physical 1-wire IBECs network via a single serial Com Port. The use of a multi-drop RS-485 satisfied this requirement. A Model 485OT9L Serial Interface Converter manufactured by B&B Electronics (www.bb-elec.com) is connected to the PC via a standard 9-pin serial cable. The converter was optioned to operate at a speed of 9600 baud and used an external wall transformer for a power supply. The RS-485 I/O of this model of converter is optically isolated from its connection to the computer. This feature will protect the computer from damage in the event that the RS-485 branch were to accidentally fault to the high voltage lighting branch.

ACT RS-485 Transceiver

The Transceiver is a full-duplex (2-way) device, which translates the ASCII commands and responses from the computer to the A10 powerline carrier modulation signals. In our demonstration installation, the single transceiver was located only a few feet from the Computer and Converter. The multi-drop RS-485

could be up to 4000 feet distant, and there could be as many as 26 individually addressable transceivers, each serving lighting branches connected to individual 277-volt distribution transformers.

ACT AX000 Coupler

The coupler includes a transformer to supply the plug-in Transceiver with its required 120 volts from the 277-volt lighting branch. An included coupler provides a bi-directional path for the 120 kHz PLC signal around the transformer. In the absence of the coupler, the 60 Hz transformer would effectively block passage of the much higher frequency A10 signal.

Wall Keypad Transmitters

Dual-button keypad wall controls were installed in existing doorway surface switch boxes for Rooms #90-2074 and 90-2082. An initial demonstration program was written that responded to depressions of the uppermost button as a request for more artificial light and would subsequently extinguish the room lighting when the lower keypad was pressed.

Relay Modules

Five ACT RF304 A10 Feed-thru Fixture Modules have been installed for the T24 switching system demonstration. The modules have a pending UL-approval and carry a 277 VAC, 20 Amp rating. Each was associated with one dual-bulb ceiling fixture and was assigned a unique A10 network address. This configuration permitted three-step control of the ceiling lighting in room #90-2074 and 2-step control in Room 90-2082.

An Example of How it Works

To understand how the demonstration system at LBNL works, we give the following example. Rubinstein wants to turn on one of the three fixtures installed in his office. Assuming that all the lights are originally off, he taps the “UP” arrow on the special wall switch (Transmitter 2) once. After the tap, transmitter 2 imposes an encoded A-10 signal on the branch circuit 11 to which it is connected. Referring to **Figure 5**, the signal travels along branch circuit 11 to the 480/277 VAC lighting circuit distribution panel located approximately 100 feet away. Because branch circuits 11 and 14 are on the same side of the lighting circuit transformer, the signal can tranverse from circuit 11 to 14 where it is decoded by the transformer on circuit 14 (physically, this transformer is in JJ’s office) and sent to the transceiver. The transceiver relays this command to the PC that is running the IBECS Server software. The server software then translates the signal into another A-10 command, which is outputted via the COM port to the transceiver, then the transformer and back onto branch circuit 14. Following the same path, in reverse, as the original signal, the signal traverses from branch circuit 14 to 11 and finally arrives at PLC relay 3 in Rubinstein’s office. This PLC relay interprets the signal and switches the connected fixture on. Since Rubinstein tapped the switch only once in this example, only PLC relay 3 was commanded on and only the one fixture switches on even through all three fixtures are on the same switchleg. In other words, the PLC Title 24 system demonstrated here can provide “virtual switchlegs” to control individual fixtures where none previously existed. At time of this writing the IBECS server software will leave the light on for one hour, then blink the light once to warn the occupant of an impending switch off. If the occupant does nothing to restore his lights, it will switch off five minutes later. All this is, of course, a function of exactly how the software is set-up. We will continue to adjust and modify the controlling software to increase functionality. (At the moment, the software is configured so that each additional tap of the UP arrow with switch on one additional light. In this way Rubinstein could turn on all three of his fixtures by tapping the transmitter three times rather than once as in the example above)

System Operation

After some initial difficulties with defective components, the system works satisfactorily. However, there is a noticeable delay between when you first tap the switch and when the light actually switches on. This delay can be decreased by modifying controlling software appropriately. One unexpected development of this system is that the lights in these offices can actually be controlled remotely from another location over the Internet. It is interesting, and possibly even useful, to have one's lights in Berkeley be controlled from, say, San Diego.

Conclusion

We successfully completed the task objectives by designing, building and demonstrating a new switching system that can provide multiple levels of light which can be triggered either from specially designed wall switches or from a digital communications network. By applying commercially available powerline carrier based technologies that communicate over the in-place lighting wiring system, this type of control can be economically installed even in existing buildings that were not wired for dual-level lighting. The demonstration system installed at LBNL shows that powerline carrier control of building lighting systems can operate satisfactorily in a realistic, electrically noisy environment.

Acknowledgment

This work was supported by the California Energy Commission through its Public Interest Energy Research Program and also by the Assistant Secretary for Energy Efficiency and Renewable Energy, Office of Building Technology, State and Community Programs, Office of Building Research and Standards of the U.S. Department of Energy under Contract No. DE-AC03-76SF00098.

Appendix A: Parts Specifications

Appendix B: Control Script for Title 24 Switching System Demonstration at Building 90

Name: Owner-Password
Class: Password
Password:
Access: Owner
Knowledge-Level: Novice
Client-Address:

Name: Owner-Password/Expert
Class: Password
Password: 0
Access: Owner
Knowledge-Level: Expert
Client-Address:

Name: Starting
Class: Choice
File: false_true.chc
Check: Yes
Init: True
Persistent: No

Name: Message
Class: Message

Name: TI103
Class: TI103
Port: COM1

Name: Michael
Class: Michael
Port: Disconnected

Name: Office-1 Timer
Class: Second-Timer
Maximum: 300

Name: Office-1 Light 1
Class: X10-Appliance
House-Code: 0
Unit-Code: 1

Name: Office-1 Light 2
Class: X10-Appliance
House-Code: 0
Unit-Code: 2

Name: Office-2 Timer
Class: Second-Timer
Maximum: 300

Name: Office-2 Light 1
Class: X10-Appliance
House-Code: M
Unit-Code: 1

Name: Office-2 Light 2
Class: X10-Appliance
House-Code: M
Unit-Code: 2

Name: Office-2 Light 3
Class: X10-Appliance
House-Code: M
Unit-Code: 3

Name: X10:HC
Class: Choice
File: x10_house_code.chc
Check: Yes
Init: (none)
Persistent: No

Name: X10>Last-HC
Class: Choice
File: x10_house_code.chc
Check: Yes
Init: (none)
Persistent: No

Name: X10:UC
Class: Choice
File: x10_unit_code.chc
Check: Yes
Init: (none)

Persistent: No

Name: X10:Last-UC
Class: Choice
File: x10_unit_code.chc
Check: Yes
Init: (none)
Persistent: No

Name: X10:FNC
Class: Choice
File: x10_function_code.chc
Check: Yes
Init: (none)
Persistent: No

Name: X10:Last-FNC
Class: Choice
File: x10_function_code.chc
Check: Yes
Init: (none)
Persistent: No

Name: Icon-Click
Class: Icon-Click

Name: Updated-Property
Class: Updated-Property

Name: Integer-A
Class: Integer
Base: Decimal
Minimum: -10000
Maximum: 10000
Init: 1
Persistent: No
:
Read-Acc: None

Name: Hex-Text
Class: Text
Init:
Persistent: No
:
Read-Acc: None

Name: Hex-A
Class: Integer
Base: Hex
Minimum: X0
Maximum: X400
Init: X0
Persistent: No
:
Read-Acc: None

Name: Character-A
Class: Character
Init: <NUL>
:
Read-Acc: None

Name: Clock
Class: Clock
Time-Zone: Eastern
Latitude: 35
Longitude: 85

Name: Sound-Card
Class: Sound-Card
TTS-Engine: Microsoft Speech Synthesis Engine:Mary

Name: Text-A
Class: Text
Init:
Persistent: No

Name: Text-B
Class: Text
Init:
Persistent: No

Name: Main
Class: Page
Property-1: Office-1 Timer
Property-2: (none)
Applet-1: line_break.app
Property-3: Office-1 Light 1
Property-4: Office-1 Light 2
Property-5: (none)
Applet-1: line_break.app
Property-6: Office-2 Timer

```

Property-7:          (none)
  Applet-1:         line_break.app
Property-8:         Office-2 Light 1
Property-9:         Office-2 Light 2
Property-10:        Office-2 Light 3

```

```

Name:               System
Class:              Page
Property-1:         Sound-Card.Status
  Applet-1:         name_value.app
Property-2:         Sound-Card.Play
  Applet-2:         name_value.app
Property-3:         Sound-Card.Speak
  Applet-3:         name_value.app
Property-4:         Sound-Card.Record
  Applet-4:         name_value.app
Property-5:         Sound-Card.Volume
  Applet-5:         name_value.app
Property-6:         Sound-Card.Control
  Applet-6:         name_value.app
Property-7:         TI103.Status
  Applet-7:         name_value.app

```

```

Name:               Time
Class:              Page
Property-1:         Clock.Year
  Applet-1:         name_value.app
Property-2:         Clock.Month
  Applet-2:         name_value.app
Property-3:         Clock.Date
  Applet-3:         name_value.app
Property-4:         Clock.Day
  Applet-4:         name_value.app
Property-5:         Clock.Hour
Property-6:         Clock.Minute
Property-7:         Clock.Second
Property-8:         Clock.Time
Property-9:         Clock.MTime
Property-10:        Clock.Weekday/Time
Property-11:        Clock.Weekday/MTime
Property-12:        Clock.Sunrise
Property-13:        Clock.Sunset
Property-14:        Clock.Daylight-Savings
  Applet-14:       name_value.app

```

```

Name:               Command
Class:              Command
Init:

```

```

Name:           Startup
Class:          Script
Description:    Startup
Control:       Enabled
Called:        No
Begin:
If Starting Is True
  {
  Do Starting Set False
  If Sound-Card.TTS-Engine Is Not (none)
  ;Then Sound-Card.Speak Set "Hello. Welcome to IBEC Server"
  }

```

```

Name:           Office-1
Class:          Script
Description:    Office-1 light control
Control:       Enabled
Called:        No
Begin:
; Respond to TK224 SRQ (so it won't send a 2ND O2/ON or O2/OFF):
If TI103.X10-RxBtn Is O/1/Status Request
  {
  Do TI103.X10-Tx Set O/1
  If Office-1 Light 1 Is Off
  Then TI103.X10-Tx Set O/Status=Off
  Else TI103.X10-Tx Set O/Status=On
  }

If TI103.X10-RxBtn Is O/1/On
  {
  If Office-1 Timer > 240
  Then Office-1 Light 2 Set On
  Do Office-1 Timer Set 300
  }

If Office-1 Timer Is Now 60
Then Office-1 Light 1 Set Off
Then Office-1 Light 1 Set On

If Office-1 Timer Is Now 0
Or TI103.X10-RxBtn Is O/1/Off
Then Office-1 Light 2 Set Off
Then Office-1 Timer Set 0

```

```

Name:           Office-2
Class:          Script
Description:    Office-2 light control
Control:       Enabled
Called:        No
Begin:

```

```

; Respond to TK224 SRQ (so it won't send a 2ND M1/ON or M1/OFF):
If TI103.X10-RxBtn Is M/1/Status Request
{
  Do TI103.X10-Tx Set M/1
  If Office-2 Light 1 Is Off
  Then TI103.X10-Tx Set M/Status=Off
  Else TI103.X10-Tx Set M/Status=On
}

If TI103.X10-RxBtn Is M/1/On
{
  If Office-2 Timer > 240
  {
    If Office-2 Light 2 Is Off
    Then Office-2 Light 2 Set On
    Else Office-2 Light 3 Set On
  }
  Do Office-2 Timer Set 300
}

If Office-2 Timer Is Now 60
Then Office-2 Light 1 Set Off
Then Office-2 Light 1 Set On

If Office-2 Timer Is Now 0
Or TI103.X10-RxBtn Is M/1/Off
Then Office-2 Light 1 Set Off
Then Office-2 Light 2 Set Off
Then Office-2 Light 3 Set Off
Then Office-2 Timer Set 0

```