

FAST AND EFFICIENT VOLATILES ANALYSIS BY PURGE AND TRAP GC/MS

C. Eric Boswell

National Air and Radiation Environmental Laboratory, Mixed Waste Analytical Program,
540 South Morris Avenue, Montgomery, AL 36115
(334) 270-7071
Boswell.eric@epa.gov

ABSTRACT

Recent changes in environmental regulatory paradigms, such as EPA's performance-based measurement systems (PBMS), are lowering method compliance barriers for laboratories working under the Resource Conservation and Recovery Act (RCRA). One of the stated goals of PBMS is to educate the regulators and the regulated community on the inherent and intended flexibility of SW-846 methods. Operating under EPA's PBMS guidelines, laboratories could employ the flexibility of SW-846 methods to simplify and improve purge and trap GC/MS volatile organic analyses (P/T GC/MS VOAs). Laboratories performing Method 8260B for P/T GC/MS VOAs have two basic GC configuration options: wide bore columns connected to the mass spectrometer through a jet separator or narrow bore columns directly interfaced to the mass spectrometer.

SW-846 methodology recognizes both approaches as valid. The narrow bore column/direct interface approach is the better of the two techniques for most analyses when certain modifications are made. When newer purge and trap concentrator designs are employed and when several Method 8260B instrument parameters are modified dramatic performance benefits result. This "enhanced" narrow bore column/direct interface approach produces results such as reduced susceptibility to column contamination by high level samples, improved chromatographic behavior of early eluting and closely eluting compounds, analysis times under 20 minutes, and improved hardware ruggedness. The outcome is better quality data, higher sample throughput, and fewer instrument mechanical failures.

INTRODUCTION

Connecting the purge and trap concentrator to the GC inlet is one of the major challenges in P/T GC/MS VOAs. The challenge stems from vastly different flow rate requirements of the purge and trap concentrator, the capillary column, and the mass spectrometer. Method 8260B¹ describes GC/MS systems equipped with either cryogenic cooling devices attached to narrow bore (0.25 mm and 0.32 mm) capillary columns or wide bore (0.53 mm) capillary columns connected to enrichment devices such as jet separators. Many laboratories choose wide bore capillary columns with jet separators when running Method 8260B because they can easily accept the high flow rates required to efficiently desorb the trap. The jet separator provides the necessary decrease in carrier gas flow rate prior to entering the mass spectrometer. The wide bore column/jet separator approach has been the traditional approach to P/T GC/MS VOAs for some time. The wide bore column/jet separator approach has a host of problems. The problems include susceptibility to column contamination by high level samples, poor chromatographic behavior of early eluting and closing eluting compounds, long analysis times (run times approaching 40 minutes), and frailty of the jet separator. Narrow bore capillaries, which potentially offer better chromatography, have not been used as much for volatiles analysis primarily because they cannot easily handle the relatively high flow rates coming from the purge and trap concentrator. Method 8260B suggests cryofocusing the analytes on a capillary pre-column interface situated between the purge and trap concentrator and the GC capillary column. This device condenses the desorbed sample components and focuses them into a narrow band that can be transferred to the analytical capillary column. However, this is an additional capital expense and it adds to the total analysis time. Newer purge and trap concentrator designs allow a much simpler interface. A conventional split/splitless injector usually already installed on the GC/MS system can be plumbed in series with the purge and trap concentrator. The operating principle is quite simple: the excess flow coming from the purge and trap is vented at the column inlet allowing a reduction in carrier gas flow rate to one more suitable for high resolution chromatography. Feyerherm and Neal^{2,3} have described how this is done with a Hewlett Packard 5890 GC. Aside from this instrument modification, the concentrator desorb time and the GC oven temperature program should be optimized to improve the chromatographic behavior of method compounds and shorten analysis time. The concentrator desorb time may be as short as 30 seconds depending on the trap material. Shortening the desorb time reduces the amount of water transferred to the GC system and thus improves chromatography. The GC oven temperature program for P/T GC/MS VOAs must accommodate compounds with a relatively wide boiling point range. The initial oven temperature will determine how well-behaved the gases (Dichlorodifluoromethane, Chloromethane, Vinyl Chloride, Bromomethane, and Chloroethane) are. Once the compounds are on the GC column, the higher boilers are not difficult to resolve. Fast (50-60°C/min.) GC oven temperature ramps can be used to save time

without any loss in resolution. This paper describes a series of modifications to Method 8260B for P/T GC/MS analysis of VOA samples. The method performance has been tested primarily with spiked water (Method 5030) in a single laboratory.

EXPERIMENTAL

Instrumentation and materials

All work was performed with an OI (College Station, TX) MPM-16 autosampler/4560 Purge and Trap concentrator. An OI tenax, silica gel, and charcoal trap (OI trap #10) was used as the sorbent trap. To connect the purge and trap, perform the following operations. Cut the total flow line to the split/splitless inlet about 3 - 4 cm from the septum nut. Using a 1/16" stainless steel union, connect the supply end to the "CARRIER IN" fitting on the purge and trap concentrator. Using another 1/16" stainless steel union, connect the transfer line from the purge and trap concentrator to the split/splitless GC inlet. These connections allow the use of the GC total flow controller to control the purge and trap desorb flow rate. All other connections are identical to other purge and trap installations. Figure 1 contains a plumbing diagram of the purge and trap concentrator-GC inlet connections. A Hewlett Packard (Palo Alto, CA) 5890 GC with EPC/Hewlett Packard 5971 MSD was employed as the GC/MS system. The analytical column used was a Restek (Bellefonte, PA) Rtx-5 (30m x 0.25mm x 1.0 μ m) with no guard column. Analytical standards were purchased from Ultra Scientific (N. Kingstown, RI) and were prepared by dilution with purge and trap grade methanol. All samples were 5 mL water samples prepared by spiking stock solutions into organic-free reagent water.

Operating Conditions

The purge and trap conditions and the GC/MS conditions are listed in Tables I and II respectively. After an 11 min. purge, the trap was heated to 180°C for 0.5 min. for sample desorption. Following the desorption step, the trap was baked at 200°C for 7.00 min. to complete the autosampler cycle. The injector was operated in the split mode with PURGE A (or B) ON all the time. A single taper 4 mm ID glass liner without glass wool was used in the GC inlet. An injector temperature of 200°C produced the best overall results. Liquid nitrogen was used to cool the oven to the initial temperature of 10°C. The GC temperature was ramped faster at the beginning and at the end of the GC oven program where the compounds exhibit a wide range of boiling points. The total carrier gas flow was 20 mL/min. and the split ratio was set at 40:1. The column flow was set at 0.5 mL/min (26.2 cm/sec.). We used a GC/MS interface temperature of 280°C.

RESULTS AND DISCUSSION

BFB may be directly injected to save time, but the injector should be operated in the splitless mode. BFB solutions are typically made up in methanol. Due to the solvent effect in splitless injections, standards made up in methanol do not give good peak shapes. Purging the BFB takes a little more time, but solves all of the above problems. We used a typically short GC oven temperature ramp for the BFB run.

Figure 2 is a total ion chromatogram of a 200 μ g/L VOA standard on a narrow bore capillary column/direct interface GC/MS system. The chromatographic run time is 17 minutes with a total GC cycle time of 20 minutes. There are no noticeable water effects in the chromatogram. Notice the gaussian peak shapes of the five gases (DCDFM, Chloromethane, Vinyl Chloride, Bromomethane, and Chloroethane). The gases give an indication of the system's overall chromatographic performance. These compounds are usually difficult to separate and typically produce poor peak shapes on 0.53 mm column/jet separator systems. Ethyl Benzene and the *m,p*-Xylene pair which are typically unresolved on a 0.53 mm column. Styrene and *o*-Xylene usually coelute on a 0.53 mm column. We achieved baseline resolution on Ethyl Benzene and the *m,p*-Xylene pair and partial resolution on Styrene and *o*-Xylene. Because of the large number of analytes, we do have several resolution challenges. Bromochloromethane and Chloroform coelute at 6.3 min. Bromoform elutes between Styrene and *o*-Xylene at 11.2 min. and is difficult to see on the total ion chromatogram. A similar close elution occurs with *sec*-Butylbenzene and 1,3-Dichlorobenzene at 13.93 and 13.94 min. None of the coeluting targets share common ions so their ion chromatograms are easily identified and quantified. For our system, a 0.5 min. desorb time dramatically reduced the amount of desorbed water while giving good chromatographic responses. With a tenax, silica gel, and charcoal trap, all compounds easily desorb at 180°C within 30 seconds with minimal carryover into subsequent blank water QC samples. For a tenax, silica gel, and charcoal trap, the purge flow rate didn't seem to affect chromatographic peak responses as much as other parameters. Purge and trap valve and transfer line temperatures around 100°C gave better results than hotter temperatures in the 180-200°C range. There was no apparent condensation of the higher boiling volatiles in the 100°C transfer line. The trap bake time was set so the purge and trap cycle time corresponded to the 20 minute GC cycle time.

The narrow bore capillary column system was calibrated by running a five-point curve with standards at 10, 20, 50, 100, and 200 µg/L (50, 100, 250, 500, and 1000 ng of standard injected). Table III is a summary of mean relative response factors (RRF), percent relative standard deviation (%RSD), method detection limits (MDLs), and estimated quantitation limits (EQLs) for selected compounds. Three of the four ketones (acetone, 2-butanone, and 4-methyl-2-pentanone) exhibit typically low RRFs, but the overall purging efficiencies are comparable to other methods. The linearity data of Table III suggest that a wider calibration range is possible for most of the VOA targets. The MDL and EQL data exhibit exceptional sensitivity for 5 mL samples. These data reflect a very simple and robust system that can generate accurate and reproducible results.

The one potential disadvantage to this approach is the requirement for sub-ambient GC oven cooling to reach the initial temperature of 10°C. This could be overcome by choosing a different GC column or a thicker film.

CONCLUSIONS

Performing split injections with P/T GC/MS VOAs allows a narrow bore column to handle the relatively high flow rates coming from the purge and trap concentrator. Narrow bore columns can be interfaced to purge and trap concentrators via split/splitless injectors by performing a relatively simple hardware modification. Combining this hardware modification with method optimizations in the concentrator desorb time and the GC oven temperature program produces dramatic performance improvements. This easy alternative to the more traditional wide bore column/jet separator approach to P/T GC/MS VOAs results in reduced susceptibility to column contamination by high level samples, improved chromatographic behavior of early eluting and closely eluting compounds, analysis times under 20 minutes, and improved hardware ruggedness.

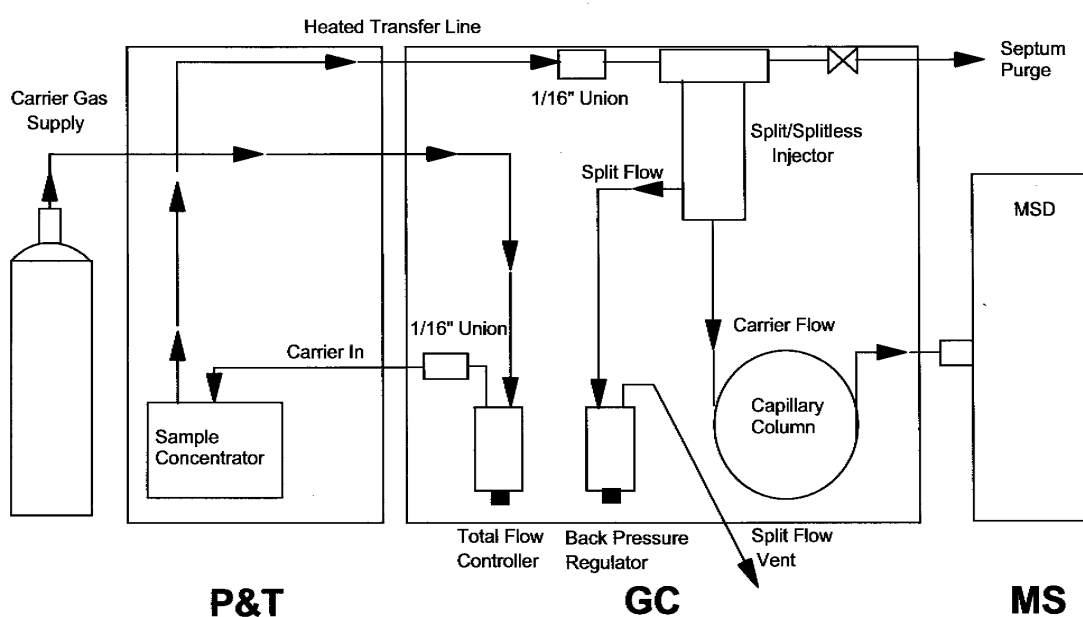

Figure 1. Basic plumbing diagram for a back pressure regulated split/splitless injector with a P/T autosampler.

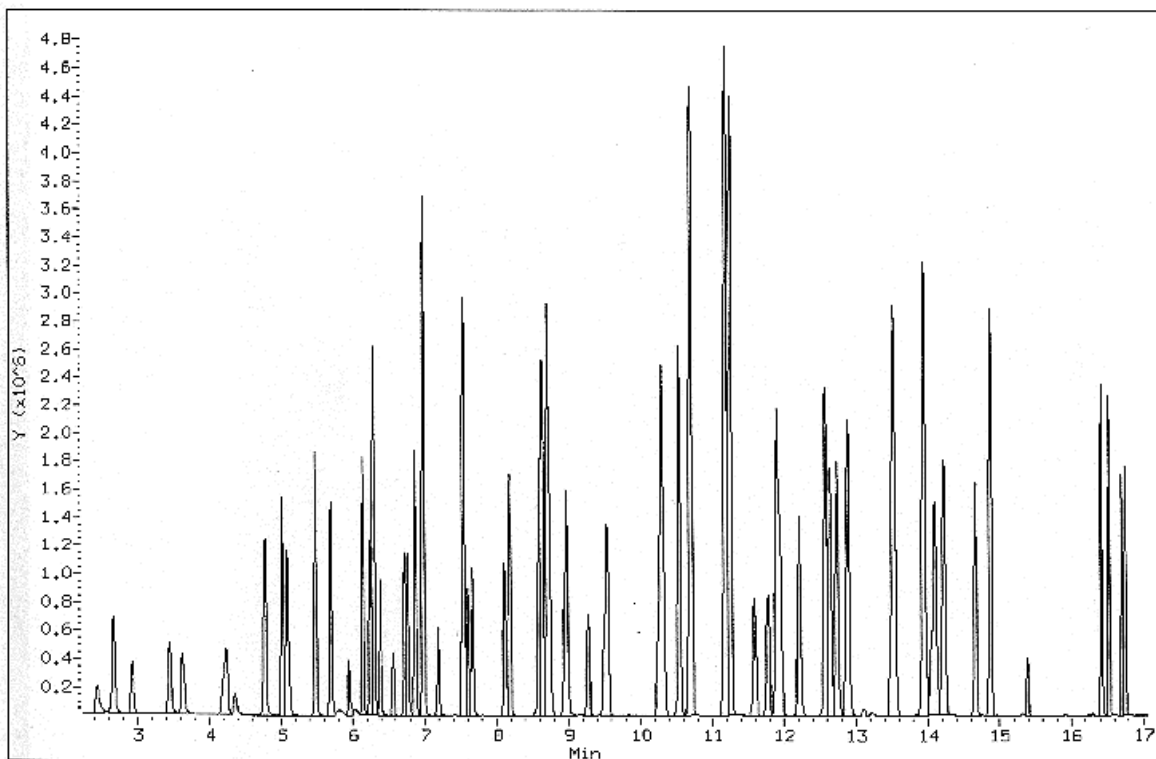

Figure 2. Total ion chromatogram of a 200 µg/L VOA calibration standard using a narrow bore capillary/direct interface system.

REFERENCES

1. USEPA SW-846 "Test Methods for Evaluating Solid Waste," Method 8260B *Volatile Organic Compounds By Gas Chromatography/Mass Spectrometry (GC/MS)*, December 1996.
2. Feyerherm, Fred; *Capillary Direct VOA's*, Hewlett Packard Company, Houston, TX, 1991.
3. Neal, Barney; *EPA Volatiles Analysis Using Narrow Bore Capillary Columns*, Hewlett Packard Company, Analytical Education Center, Atlanta, GA, 1992.

TABLE I. Purge and Trap Conditions.

Trap Material	Tenax, Silica Gel, and Charcoal (OI trap #10)
Sample Volume	5 mL
Purge Flow Rate	40 mL/min.
Purge Temperature	ambient
Purge Time	11 min.
Desorb Temperature	180 °C
Desorb Time	0.5 min.
Bake Temperature	200 °C
Bake Time	7 min.
Valve Temperature	100 °C
Transfer Line Temperature	100 °C

TABLE II. GC/MS Conditions.

Injector Mode	Split
GC Inlet Liner	Single taper, 4 mm ID, no glass wool
GC Inlet Temperature	200 °C
Total Flow	20 mL/min.
Septum Purge	3 mL/min.
Column	Rtx-5, 30 m x 0.25 mm, 1 µm film
Column Linear Velocity	26.2 cm/sec. (0.5 mL/min.)
GC Oven Ramp	Hold 2.0 min. @ 10 °C 10 - 90 °C @ 20 °C/min. 90 - 140 °C @ 6 °C/min. 140 - 240 °C @ 60 °C/min Hold 1.5 min. @ 240 °C
GC-MS Interface temperature	280 °C
Scan Range	35-300 amu
Solvent Delay	2 min.

TABLE III. Summary of mean RRFs, %RSDs, MDLs, and EQLS for selected compounds.

COMPOUND	MEAN RRF	%RSD	MDL (ppb)	EQL (ppb)
Chloromethane	1.09818	1.336	0.14	0.45
Bromomethane	0.48876	1.467	0.36	1.20
Acetone	0.07834	2.717	1.23	4.11
2-Butanone	0.09202	4.150	1.10	3.66
Chloroform	0.95677	2.073	0.18	0.60
Benzene	1.50253	3.086	0.05	0.18
Ethyl Benzene	1.71616	1.807	0.06	0.21
1,3-Dichlorobenzene	1.46463	2.014	0.12	0.40
Hexachlorobutadiene	0.41990	4.389	0.19	0.64
1,2,3-Trichlorobenzene	0.83833	4.532	0.35	1.17