

Appendix B Description of the Proposed Facility

The Regenesys™ Energy Storage Facility will store energy when demand for electricity is low and be used as a power source when demand is high. The facility is expected to release about 12 megawatts of electricity for a duration of several hours and is expected to be operational for about 15 years. Construction of the facility is scheduled to begin in the summer of 2001 and be completed by the summer of 2002. Commissioning of the facility, scheduled to last approximately six months, would begin shortly after construction is complete.

Construction of this facility would include the erection of a process building and installation of two large cylindrical storage tanks (30 feet tall and approximately 65 feet in diameter) adjacent to the process building. A wall will be erected around the tanks to serve as a visual screen and will also be designed to serve as spill containment. The process building, approximately 175 feet long, 65 feet wide, and 60 feet tall, will contain the required modules, electrolyte circulation pumps, electrolyte supply headers, and associated pipework. A photograph of the first Regenesys™ facility currently being constructed in the United Kingdom is shown in Figure B-1. Major components of the Regenesys™ Energy Storage Facility are shown in Figure B-2. The proposed layout of the facility is shown in Figure B-3, with elevations shown in Figure B-4. A conceptual plan view of the facility is superimposed on each alternative site in Figure B-5.

The process building will be mechanically ventilated to two, carbon-bed adsorbers. Minimal heating and air conditioning of the control room will be accomplished with a small heat pump. The power conversion system will be located in an electrical annex within the main building. The area required for installation is approximately four acres. This relatively small area will accommodate the structures listed above, as well as the required auxiliary components. Other actions connected to the construction of the facility are the installation of a transmission line from the facility to the host substation and connections to local utilities, such as water and sewer.

Description of the Technology

The system stores or releases electrical energy by means of a reversible electrochemical reaction between two salt solutions or electrolytes. In the uncharged state, the electrolytes used in the Regenesys™ system are concentrated solutions of sodium bromide and sodium polysulfide. On charging, the bromide ions are oxidized to bromine and complexed as tribromide ions. Sulfur present in the polysulfide anion is converted to sulfide as shown below:

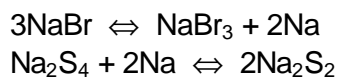

Electrolyte solutions circulate in separate circuits and are separated by a cation-selective membrane in the modules. Electrical balance is achieved by transport of sodium across the membrane. Each module has a voltage potential of 1.5 volts. High voltages required for supplying power are achieved by linking these modules together, with the cathode of one cell becoming the anode of the next cell. Two hundred modules linked in this fashion form a 300-volt module. During operation, each module must be supplied with a constant flow of electrolyte re-circulated from the storage tanks through a series of distribution manifolds. During charging and discharging, each electrolyte is pumped at a rate of approximately 5000 gpm.

Electrolyte solutions are stored in one of two double-walled tanks. The sodium bromide tank would have a capacity of 475,000 gallons and the sodium polysulfide tank would have a capacity of 570,000 gallons. The volume of electrolytes in the tanks varies during charging and discharging operations. The volume of sodium bromide decreases during charging, while the volume of sodium polysulfide increases. During power discharge, the changes in electrolyte level are reversed.

The principal components of the Regenesys™ Power Storage Facility are:

- Regenerative flow battery modules located in the process building.
- Two electrolyte storage tanks.
- A process facility, including an electrolyte circulation system.
- A power conversion system, including an inverter/rectifier, transformer, and alternating current breaker.
- Control systems.
- Auxiliary systems that include electrolyte and power-conversion-system cooling, and an electrolyte management system.

For efficient operation of the Regenesys™ system, bromine levels in the sodium bromide electrolyte must be adjusted and sodium sulfate, formed as a byproduct, must be removed. This is accomplished by an Electrolyte Management System (EMS) which processes sodium bromide solution as it returns to the electrolyte storage tank. The EMS consists of a series of tanks and electrochemical modules that reduce the bromine level and adjust pH in the solution, and a crystallizer that removes sodium sulfate. Sodium-sulfate crystals will be produced at a rate of 126 lb per hour. Depending on market conditions, the sodium sulfate will be sold in the bulk chemical market or disposed of as solid waste.

Heat generated in the process will be removed by a plate cooler located in the polysulfide electrolyte circulating system. The power conversion system, which provides interface between the alternating current electrical supply system and direct current generated by the modules, also requires cooling. A wet draft cooling tower with a capacity of 10,000,000 BTU will provide water for these two cooling operations. Purge water will be discharged to the local sewer system at a rate of 5 gpm. The cooling water may require the addition of anti-corrosion chemicals, anti-scaling chemicals, as well as a biocide. The requirement, choice of chemicals and dose rate will be based on the quality of makeup water.

The Regenesys™ Energy Storage Facility can be operated remotely. Personnel are required for the following operations:

- Routine maintenance.
- Removal of solid waste.
- Replacement of spent absorbent.
- Replenishment of electrolyte solution and water treatment chemicals.

With the exception of sodium sulfate removal, it is estimated that the above activities will be done quarterly. Sodium sulfate will be removed once every two weeks.

In summary, the Regenesys™ Energy Storage Facility is a closed-loop system that produces relatively small amounts of gaseous, liquid, and solid waste.



Figure B-1 Current Construction of a Regenesys™ Facility

REGENESYS™ COMPONENTS

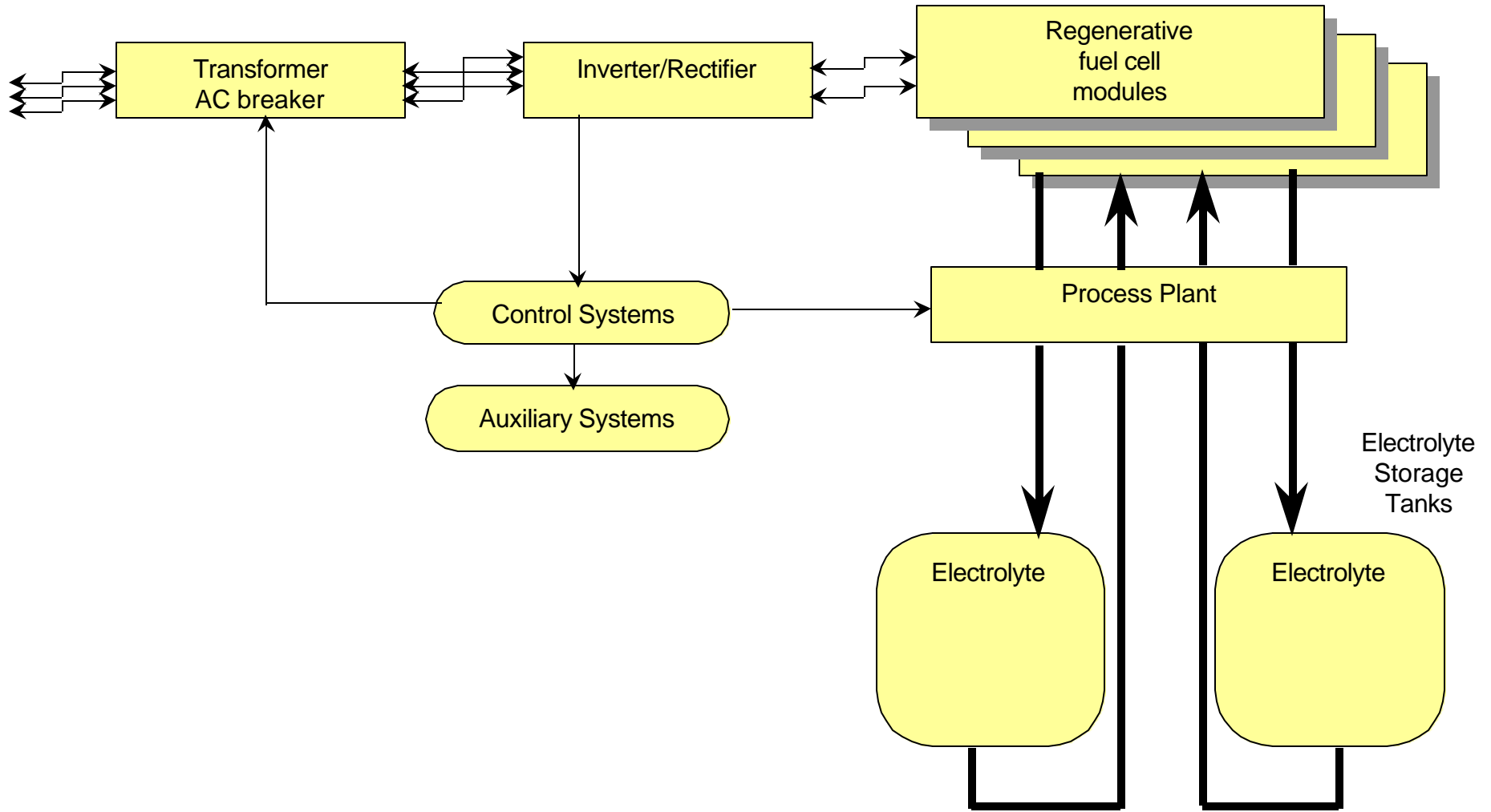

Figure B-2

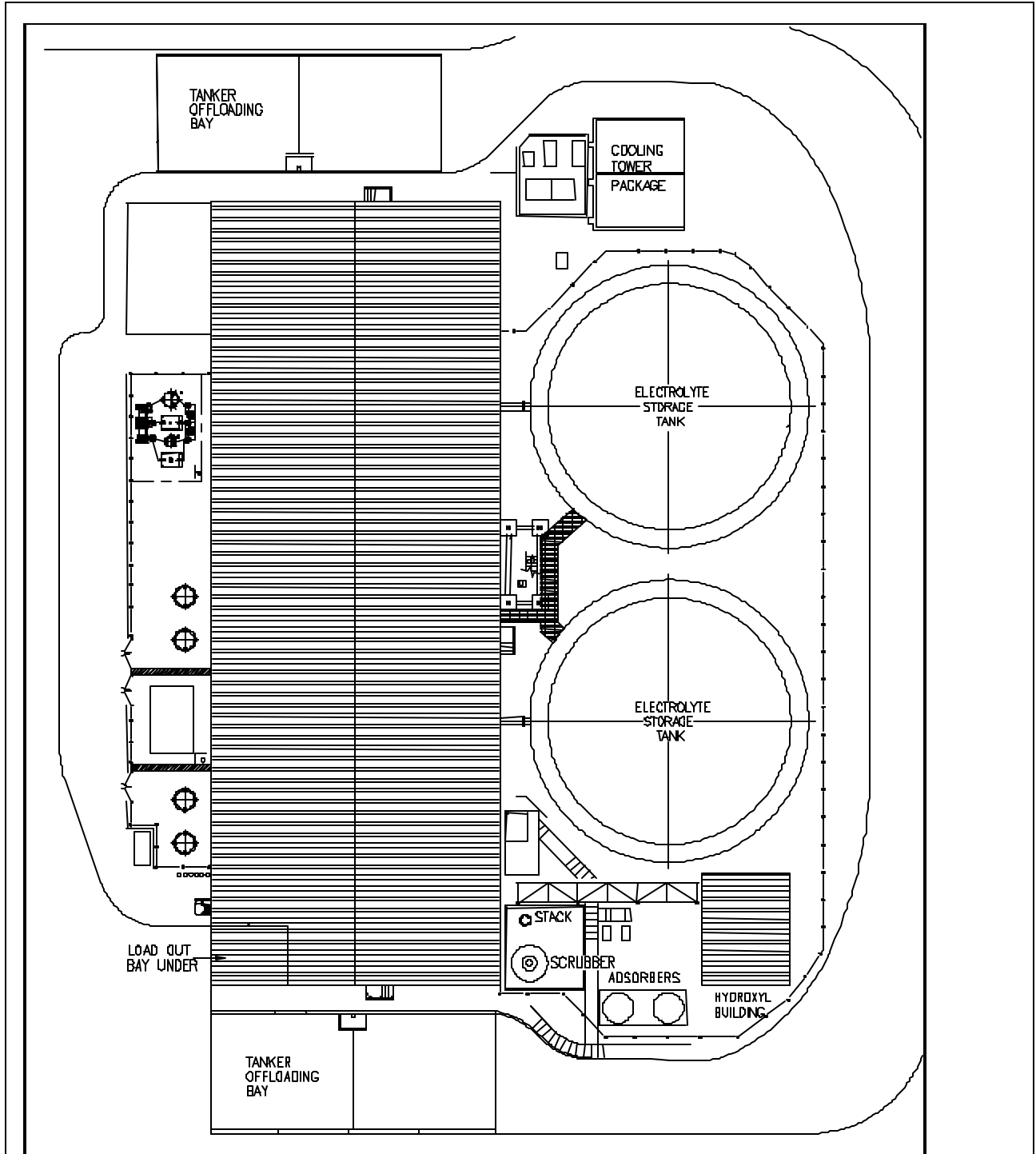

Figure B-3 Regenesys™ Plan View

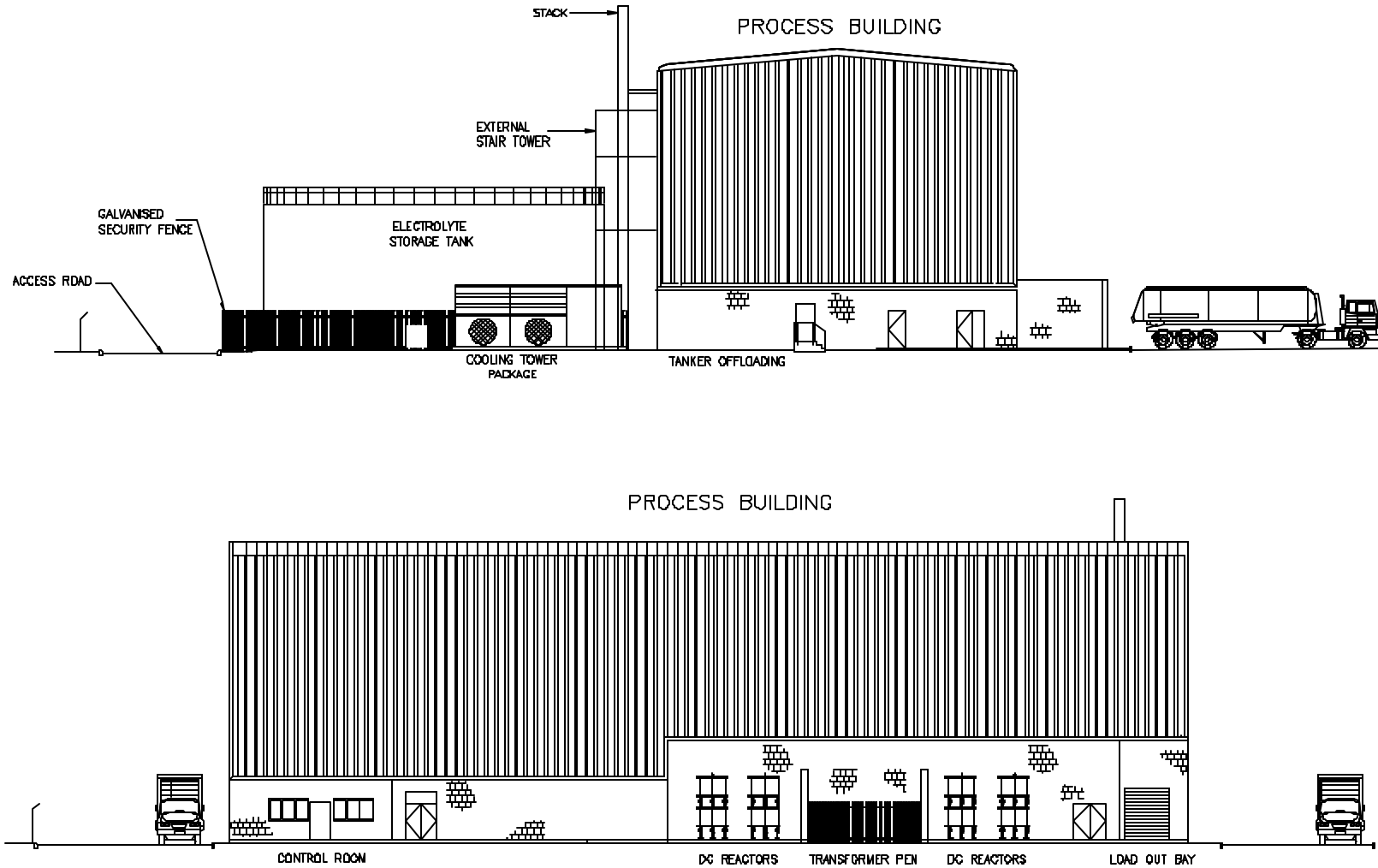

Figure B-4 Regenesys™ Elevation View

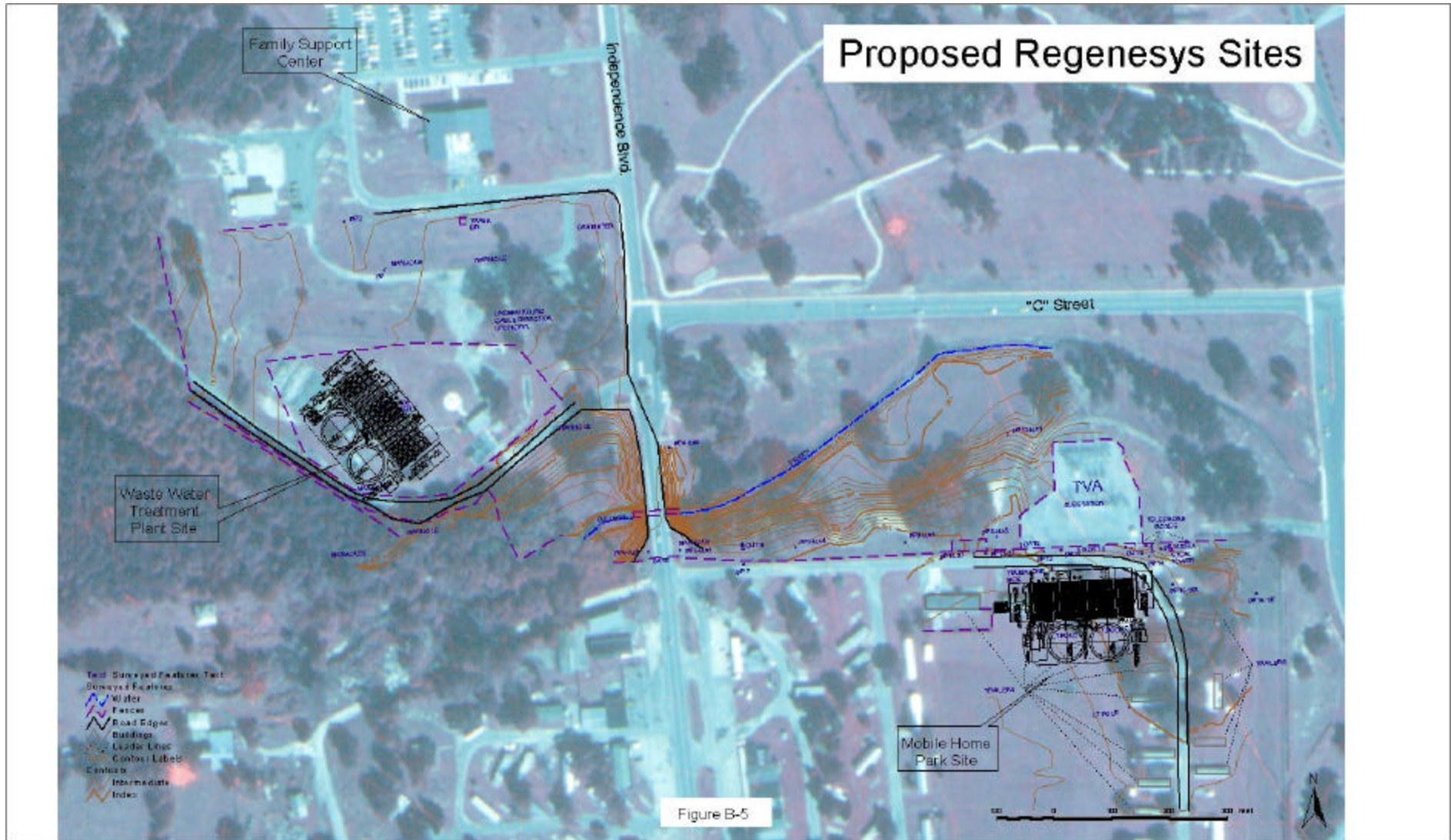

Figure B-5

VENT SYSTEM & EMISSIONS CONTROL DEVICES

